

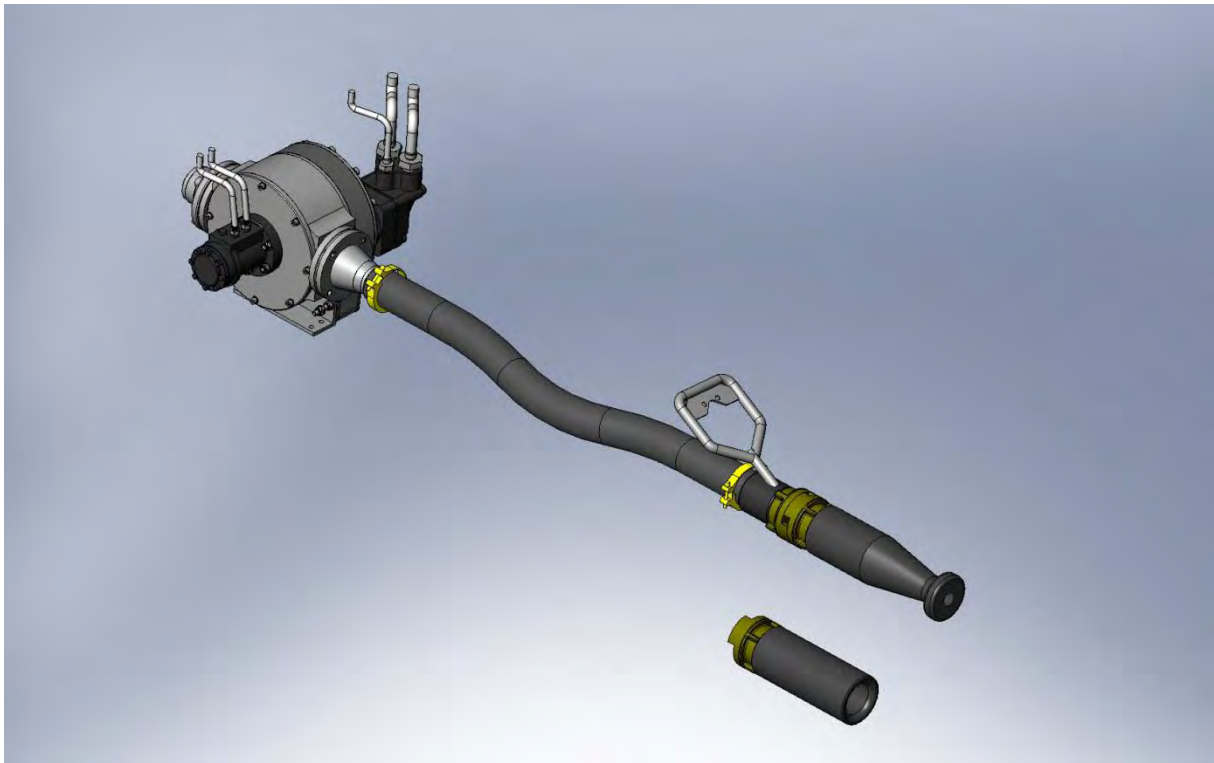

Faculty of Science and Technology

MASTER'S THESIS

Study program/ Specialization: Offshore technology Subsea technology	Spring semester, 2011 Open
Writer: Simon Bruset (Writer's signature)
Faculty supervisor: Mohsen Assadi External supervisor: Gjermund Rath – Oceaneering A/S	
Title of thesis: Modification of Suction Kit	
Credits (ECTS): 30	
Key words: Oceaneering A/S, Suction Kit, Centrifugal pump, special effect pump, reversible flow, pressure loss	Pages: + enclosure: Stavanger, Date/2011



Modification of Suction Kit

Master Thesis Spring 2011

Written by Simon Bruset

University of Stavanger

Summary

This thesis is about the modification of an ROV mounted Suction Kit; a reversible centrifugal pump designed and manufactured by Oceaneering AS. The Kit mainly contains a centrifugal pump driven by a hydraulic pump motor and a flow regulator enabling the function of a reversible flow. Oceaneering AS gave me the challenge to improve the Suction Kit to meet requirements and specifications put forward by a client. In addition Oceaneering also presented some internal requirements, where the most important one being to keep the dimensions of the Suction Kit as it is.

There are several requirements, but in this thesis it will be focused on increasing the flow rate from 1300 liter/min to 2000 liter/min. This is an increase of 700 liters or 53%. In regard to pumps, an increase in flow rate of over 50% while keeping dimensions unchanged, is a challenge. The modifications performed in this thesis are based on basic pump theory and test results. Some of the changes include modifying the impeller, improving the flow path and removal of the flow regulator. The maximum flow achieved was 1823 liters/minute.

Preface

During the spring semester of 2011 I have been writing my master thesis at the University of Stavanger. Writing this thesis has been challenging especially in the start, as pumps have not been covered to a large extent in any of my courses. Nevertheless it has been an educational process giving me a good insight in the subject of pumps. This includes a better understanding of how they work, way of operation, theory, basics of flow path design, fluid flow, pressure losses and not at least, how to perform practical testing of pumps.

Pumps are frequently used equipment in the industry and therefore of interest for me as a mechanical engineer. Further it is a useful tool during subsea operations and therefore very applicable for me in my future career as a subsea engineer. The work with this thesis has provided me with useful theoretical and practical experience for future offshore operations.

Having worked at Oceaneering A/S in the summer of 2010, I contacted them to see if they had a subject for my master thesis. During an initial discussion with head of the DTS Tooling department, Gunnar Mathias Ulland, I was presented with the challenges they had with the Suction Kit. This was an interesting challenge with the inherent possibility of a combined theoretical and practical oriented thesis.

I would like to thank my Supervisors Peter Brehaus and Mohsen Assadi at IRIS, who has provided me with ideas and feedback during the writing of this thesis. I would also like to thank Promet A/S for great service and quick deliveries of critical parts. Engineers, designers and mechanics at Oceaneering A/S deserve an acknowledgment for their help and assistance. I would also like to extend my gratitude to Olav Brusset for the invaluable effort giving his thoughts and comments throughout the whole process of writing this thesis.

Stavanger, June 2011

.....

Simon Brusset

Definitions and abbreviations

BOP – *Blow Out Preventer*

Equipment used during drilling operations fitted with various valves and safety devices. This is to enable safe drilling and isolation of hydrocarbons if required.

Casing 1 –

Referring to the original impeller casing of the Suction Kit, designed for Impeller 1.

Casing 2 –

The modified impeller casing to fit Impeller 2.

Casing 3 –

Has the same dimensions as Casing 2, but designed for a better flow path from the impeller casing to the top casing.

DTS Tooling department – (*Deepwater Technical Solutions*)

Is the department at Oceaneering that produces and develops different tools to be used by ROV's for a wide range of different operations.

Flow regulator – *Regulates flow direction*

This part regulates the flow direction in the Suction Kit. It enables the operator to switch between blowing and suction mode, see Figure 4.1.

GPM – *gallon per minute*

Measurement for flow rate, typically used in USA.

HP – *Horse power*

A measurement of power.

HPU – *Hydraulic Power Unit*

Is normally an electric motor driving a hydraulic pump to provide hydraulic power to different functions.

Impeller 1 –

The original impeller.

Impeller 2 –

A modification of Impeller 1.

LB – *libra*

Abbreviation of the Roman word “*libra*” for the unit of mass “*pound*”.

LBF – *Pound-force*

A unit of force, defined as follows: $1 \text{ LBF} = 1 \text{ LB} \cdot g$

where g is the gravitational force.

LBF FT – *Foot pound force (energy)*

A unit of work or energy. It is the energy transferred on applying a force of 1 pound force (LBF) through a displacement of 1 foot.

LPM – *liter per minute*

Used in this thesis as a measurement for flow rate.

Motor 1 –

The original motor. A 9,8 cm³ hydraulic motor driving the impeller.

Motor 2 –

A 14,3 cm³ hydraulic motor to replace Motor 1.

N/P – *Not possible*

Code used if a result was not achievable while testing. This is in most cases when trying to measure flow rate at a hydraulic pressure range of 190-200 bar.

NPSH – *Net positive suction head*

PSI – *Pound-force per Square Inch*

A unit of pressure based on avoirdupois units. It is the pressure resulting from a force of one pound-force applied to an area of one square inch. 1 psi approximately equals 6 894,757 Pa (pascal), or 0,068948 bar.

RPM – *rotation per minute*

ROV – Remote Operated Vehicle

A work type ROV is normally powered and controlled by electrical power and signals. It typically has a hydraulic power pack or unit (HPU) installed. This HPU normally provide power to the thrusters, manipulators and various mounted equipment such as motors, torque tools, wire cutters etc.

ROV pilot –

A person operating and controlling the ROV from the surface.

Top Casing –

Used in this thesis to describe a part containing the flow regulator, the inlet and the outlet. It can be seen in Figure 4.1.

Conversion factors

1	Kg	2,2	lb
1	Mm	0,039	in
1	cm³	0,061	cu in
1	liter (1 dm³)	0,264	US gallon
1	Bar	14,5	psi
1	N	0,225	lbf
1	Nm	0,738	lbf ft
1	kW	1,34	hp
1	lpm	0,26	US gpm

Table of content

Summary	iii
Preface.....	iv
Definitions and abbreviations	v
Conversion factors.....	viii
List of figures	xii
List of tables	xiii
1. Introduction.....	1
2. Specification of thesis.....	2
2.1. Scope and limitations	2
2.1.1. Requirements from Statoil	2
2.1.2. Specifications from Oceaneering	3
2.1.3. Industrial requirements - API and ISO standards.....	3
2.1.4. Specifications and execution for testing of the pump.....	4
3. Pump basics.....	6
3.1. Pump classification	6
3.1.1. Positive displacement pumps	6
3.1.2. Kinetic pumps	7
3.1.3. Centrifugal pumps	9
3.2. Blade angles influence on degree of reaction.....	10
3.3. General components of Centrifugal pumps	12
3.3.1. Casing	12
3.3.2. Seal Chamber and Stuffing Box	13
3.3.3. Impeller	13
3.4. Various aspects of pumps.....	15
3.4.1. Capacity	15
3.4.2. Head	15
3.4.3. Efficiency	16
3.4.4. Cavitation	16
3.4.5. Affinity laws.....	18
3.4.6. Pressure loss.....	19

3.5.	Problems and wear	22
4.	Info about the Suction Kit	23
4.1.	General	23
4.2.	Evaluation of the Suction Kit	28
4.2.1.	Head	28
4.2.2.	Capacity	28
4.2.3.	Ease of operation	29
4.2.4.	Efficiency	29
4.2.5.	Size and weight.....	29
4.2.6.	Dependability	30
4.2.7.	Maintainability	30
4.3.	Range of applications	31
4.4.	Flow path	32
4.5.	Reversible function.....	34
5.	What influences the flow rate?.....	35
5.1.	General	35
5.2.	Pump charts.....	35
5.3.	Theoretical assessment	37
5.4.	Revolutions Per Minute	39
5.5.	Pressure loss and flow resistance.....	40
5.5.1.	General	40
5.5.2.	Resistance coefficients	41
6.	Improvements	46
6.1.	General	46
6.2.	Definition of parts.....	46
6.2.1.	Motor.....	46
6.2.2.	Impeller	47
6.2.3.	Casing	47
6.3.	Limitations.....	48
6.4.	Impact of modifications.....	50
6.4.1.	Test setup	50

6.4.2.	Impeller	50
6.4.3.	Motor.....	51
6.4.4.	Impeller casing	53
6.4.5.	Grinding and polishing	56
6.5.	Results of modifications	57
7.	Conclusion	63
8.	Recommendations for further work	65
9.	References.....	66
Appendix.....		67
	Specification defined by Oceaneering	68
	Specification defined by Statoil.....	69
	Test log	70
	Additional photos.....	83

List of figures

Figure 2.1.1: Showing the test setup.	5
Figure 3.1: Two examples of fixed displacement pumps.....	7
Figure 3.2: Illustration of a centrifugal pump[5].....	8
Figure 3.3: Categorization of pump.....	9
Figure 3.4: Different velocity triangles for different values of impeller blades.[7]	10
Figure 3.5: Volute casing.	12
Figure 3.6: Circular casing.	13
Figure 3.7: Common types of impellers for centrifugal pumps.	14
Figure 4.1: A fully assembled Suction Kit	23
Figure 4.2: Illustration of Suction Kit.....	24
Figure 4.3: Exploded view of a Suction Kit	24
Figure 4.4: Illustration of the impeller	25
Figure 4.5: Impeller 2	26
Figure 4.6: The Suction Kit seen from the	32
Figure 4.7: The Suction Kit, viewed from the bottom.....	33
Figure 4.8: The Suction Kit viewed from the top.	33
Figure 4.9: The flow regulator.....	34
Figure 5.1: Pump chart for different models of a centrifugal pump.....	36
Figure 5.2: Components of velocity in an impeller[7].....	38
Figure 5.3: Shows an illustration of the impeller	39
Figure 5.4: Three different situations of pressure loss	41
Figure 6.1: Illustration of the impeller casing, Casing 2.	53
Figure 6.2: The improved casing, Casing 3	54
Figure 6.3: Shows the Suction Kit without the top casing and Flow regulator.....	55
Figure 6.4: Shows the Top casing untreated.....	56
Figure 6.5: Top casing grinded and polished.....	56
Figure 6.6: Shows the bottom of the plate after treatment.....	57
Figure 6.7: Showing the top of the plate after treatment.	57
Figure 6.8: Graphs from the different tests.	58
Figure 6.9: Total “real” increase.....	60
Figure 6.10: Total increase.	61
Figure 7.1: Box diagram showing max flow rate from the different tests.....	64

List of tables

Table 1: Showing the results for different angles for different impeller blades.[7]	11
Table 2: Specifications of the original motor used in the Suction Kit.....	27
Table 3: Results from the different tests with different modifications.	59
Table 4: Shows the increase in flow rate due to the different modifications.	62
Table 5: Modifications performed in the different tests.	64

1. Introduction

Pumps are one of the most frequently used machines in the industry and society today, and are used for a wide number of different applications[1]. The Suction Kit in this thesis is a reversible centrifugal pump; i.e. it provides suction and/or pressure depending on the position of the flow regulator. This position is selected remotely by the ROV pilot. It is an important tool and is mounted on the ROV in most of the operations. It is used for a number of different subsea operations.

The Suction Kit is produced and developed by Oceaneering A/S. Oceaneering does not primarily work with pumps and that could be a reason that general info regarding the pump, i.e. pump charts, is not available or have not been worked out. The lack of documentation will make it more difficult to answer some technical questions regarding this Suction Kit than it usually is when working with pumps, as these documents usually are available.

Oceaneering has received requirements and specifications for this type of Suction Kit from Statoil, as being one of the main customers. If the Suction Kit is to be used in any operations under management of Statoil, the Suction Kit must fulfill these requirements and specifications.

The scope of this master thesis is to propose modifications to the Suction Kit to meet the given specifications. Further a report shall be provided to document the theoretical and design studies, modification work and testing that has been done while working with this thesis. This documentation can also be used to support the implementation of the proposed improvements to the Suction Kit. The requirements regarding the flow rate of the Suction Kit will be prioritized (see specifications from Statoil). Other specs will be considered depending on time and effort to fulfill the problems and the given time to write the master thesis.

The methods used to meet the given requirements will be presented along with an evaluation of how to optimize the design of the Suction Kit. Extensive testing will be necessary in close connection with the calculations and discussions in order to solve the different problems.

2. Specification of thesis

2.1. Scope and limitations

Statoil has listed a number of requirements and specifications regarding ROV mounted Suction Kits; a draft of the requirements is listed below. This thesis will focus on the required flow rate of the Suction Kit.

In addition to the requirements from Statoil, Oceaneering has some specs regarding the Suction Kit. The design specifications are mainly stated to enable the Suction Kit to be mounted on an ROV, due to limitations on weight and dimensions of ROV mounted tools, besides keeping costs as low as possible.

2.1.1. Requirements from Statoil

- One HPU skid with two independent pump circuits with the following specifications:
Circuit 1: High pressure, low flow rate.
Circuit 2: Low pressure, high flow rate.
- The pump should be able to provide at least 2,5 bar (250kPa or 36psi) relative overpressure or underpressure (suction) in the skirt compartments/suction pile.
- It should be possible to increase the suction linearly.
- There shall be an easy readable indicator showing when pressure or suction is applied. The indicator shall be clearly visible by use of the ROV cameras.
- The pump shall enable reasonable leveling velocities; i.e. the pump capacity should be at least 2000 liters/minute (530 gpm).

See Appendix B for the complete list of Statoil's requirements.

2.1.2. Specifications from Oceaneering

- The Suction Kit should have a capacity to obtain a pressure of at least 2,5 bar; suction and pressure, in submerged state, i.e. in depth of 25 meters or more.

Specs regarding design:

- Max weight in water is set to 30 kg.
- Current dimensions should not be exceeded.
- The Suction Kit should be kept as it is, especially regarding mechanical interface and hydraulic connection.

See Appendix A for the complete list of Oceaneering's requirements.

2.1.3. Industrial requirements - API and ISO standards

The API standard 610 "Centrifugal Pumps for Petroleum, Heavy Duty Chemical, and Gas Industry Services" (eighth edition, august 1995) (identical to ISO standard 13709:2009) covers the minimum requirements for centrifugal pumps also including pumps running in reverse, for use in petroleum, heavy duty chemical and gas industry services. Further the standard specifies that for nonflammable, nonhazardous services not exceeding certain limits (listed below), the purchasers may wish to consider pumps that do not comply with API Standard 610. The limits referred to are

- Max discharge pressure 1900 kPa (pressure relative to the surrounding atmosphere)
- Max suction pressure - 500 kPa
- Max pumping temperature 150°C
- Max rotative speed 3600RPM
- Max rated total Head 120 m
- Max impeller diameter (overhung impeller) 330 mm

With regards to the given limits, the Suction Kit does not need to meet this standard. But the purchaser might request that it is. However, requirements related to e.g. testing and inspection could be used, but the testing requirements specified in this standard are too extensive for this pump.

With further modifications, the Suction Kit might pass a max rotational speed of 3600 RPM. In this case it will have to meet this standard[2].

2.1.4. Specifications and execution for testing of the pump

The testing rig consists of the following equipment:

- 2 x 1000 liter tanks
- Suction Kit
- Pressure sensors for inlet and outlet
- HPU, capacity ca.80 liter/minute
- Hoses from HPU to Suction Kit, ½" supertuff JIC 12
- Hoses for drain
- Flow meter from HPU to Suction Kit

The equipment is set up as can be seen in Figure 2.1 and 2.2.

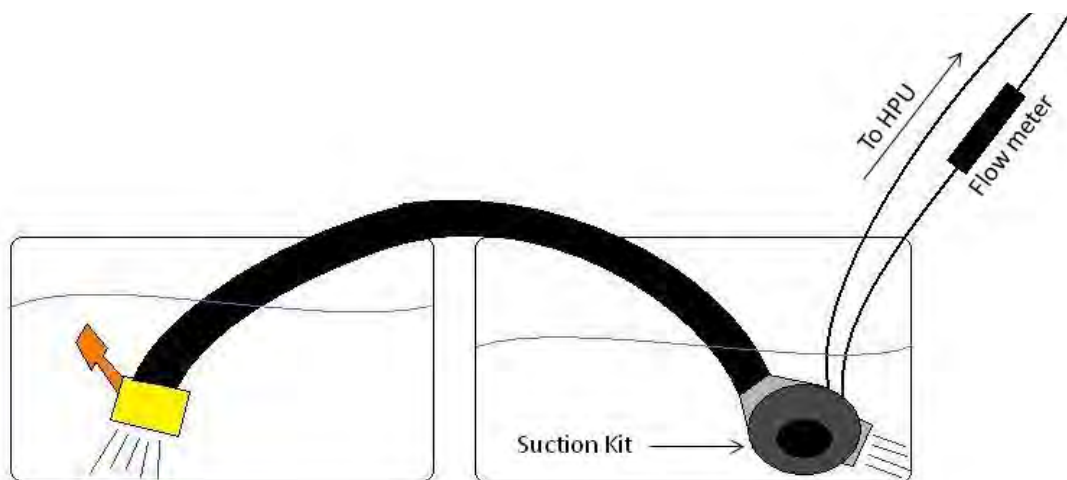

Figure 2.1: Illustration of test setup

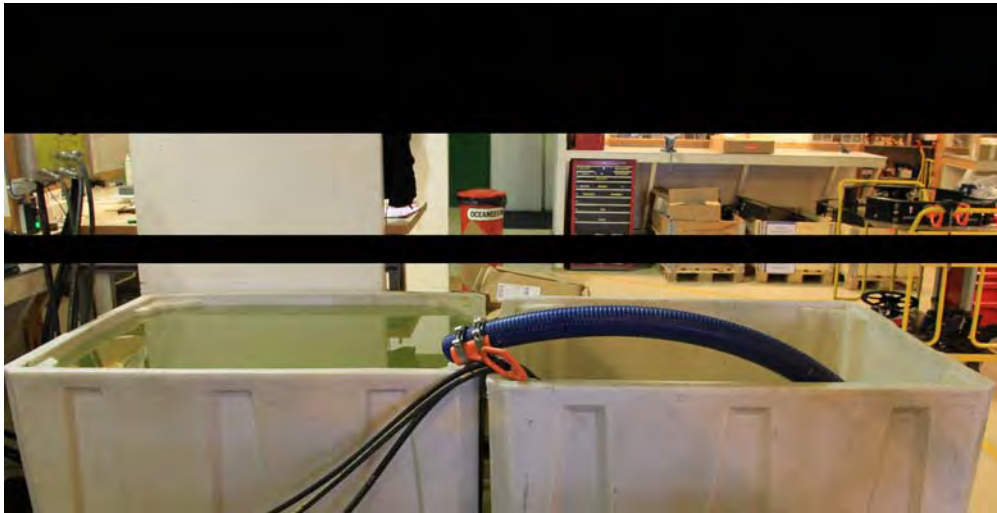

Figure 2.2: Showing the test setup.

While testing the Suction Kit it is necessary to measure as many parameters as a base to do calculations, if needed, and to get an understanding of the Suction Kit. This can further give information that can be used to make estimations about what is happening inside the Kit.

Following parameters will be logged:

- Flow rate (based on time)
- Pressure (from HPU)
- Flow rate (from HPU)
- Pressure
- RPM (will be calculated based on flow rate from HPU and size of motor)

A flow meter is used to supervise the output (liters/minute) from the HPU to the Suction Kit's motor. It can be used to determine the number of revolutions per minute of the pump rotor. Pressure sensors will be mounted on the inlet and outlet; to measure inlet pressure, outlet pressure and the resulting Δp .

The flow rate will be measured by measuring the time the Suction Kit needs to fill a given volume. To achieve higher accuracy will the Suction Kit pump 100 liters before we start the

measurement. This will ensure that the flow is more steady and better represent the average flow. Then the time to fill up the rest of the volume is measured.

3. Pump basics

3.1. Pump classification

A pump is defined as a device used to move liquids[3]. A pump displaces a volume by physical or mechanical action. We usually divide pumps into two categories;

- Positive displacement pumps (hydrostatic)
- Kinetic pumps (hydrodynamic)

Almost all pumps fall into one of these two categories. The main difference between kinetic and positive displacement pumps is the method used to transfer the power to the fluid.

3.1.1. Positive displacement pumps

A positive displacement pump moves a fixed volume of fluid within the pump casing by applying a force to moveable boundaries containing the fluid volume. Explained in a less complicated way; for each revolution the hydrostatic pump delivers a volume equal to the volume swept by one stroke by e.g. the piston. Positive displacement pumps are often divided into two major categories; reciprocating and rotary pumps. Reciprocating pumps transfer a volume of fluid by a crankshaft, eccentric cam or an alternating fluid pressure acting on a piston, plunger or a diaphragm in a reciprocating motion (see Figure 3.1 A).[4]

A big difference between reciprocating pumps and centrifugal pumps is that reciprocating pumps are not producing a continuous flow, they are intermittent working machines. In contrast, standard turbo-machines or centrifugal pumps produce a continuous flow. Reciprocating pumps only produce flow and pressure when e.g. the piston moves up. As a result of this there are flow fluctuations as well as pressure fluctuations. However, a triplex-pump i.e. with three cylinders, fitted with a suitable pulsation damper, will produce a fairly stable flow rate.

Rotary pumps operate by transferring a volume of fluid in cavities located between a stationary component inside the pump or casing (see Figure 3.1 B)[4]. They are in this way producing a more continuous flow than reciprocating pumps.

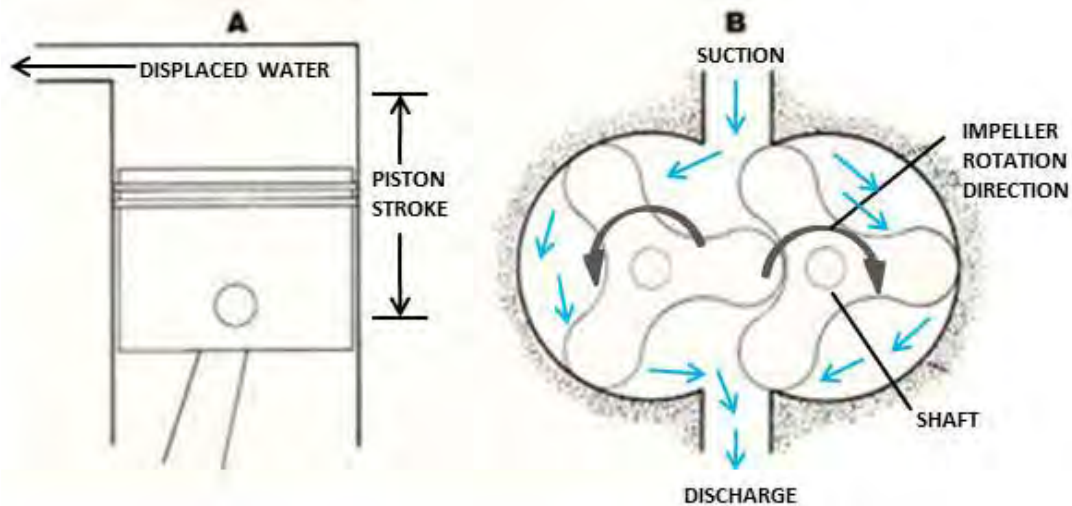

Figure 3.1: Two examples of fixed displacement pumps. A shows an example of a reciprocating pump, in this case a piston pump. B shows a multiple rotor pump, a version of rotary pumps.

3.1.2. Kinetic pumps

For a kinetic pump the delivered volume depends on the discharge pressure. We can say that a kinetic pump transfers kinetic energy to the fluid, which is gradually converted to pressure as the fluid leaves the impeller towards the exit of the pump. The most frequent used kinetic pump is the centrifugal pump which can be seen in Figure 3.2.

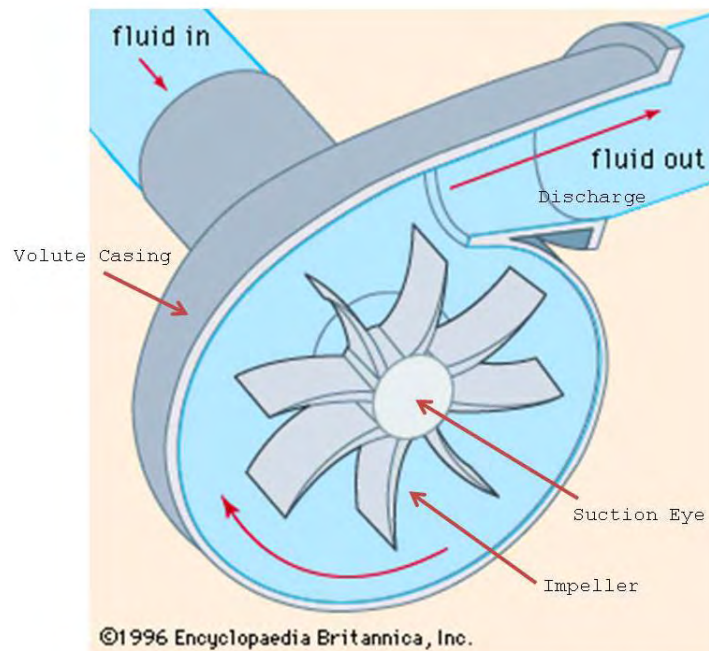

Figure 3.2: Illustration of a centrifugal pump[5]

Kinetic pumps can further be divided into two categories; centrifugal and special effect (see Figure 3.3). Types of special effect pumps include jet pumps, reversible centrifugal pumps and gas lift[4]. The Suction Kit in this thesis is a reversible centrifugal pump, which means it falls into the category of special effect pumps.

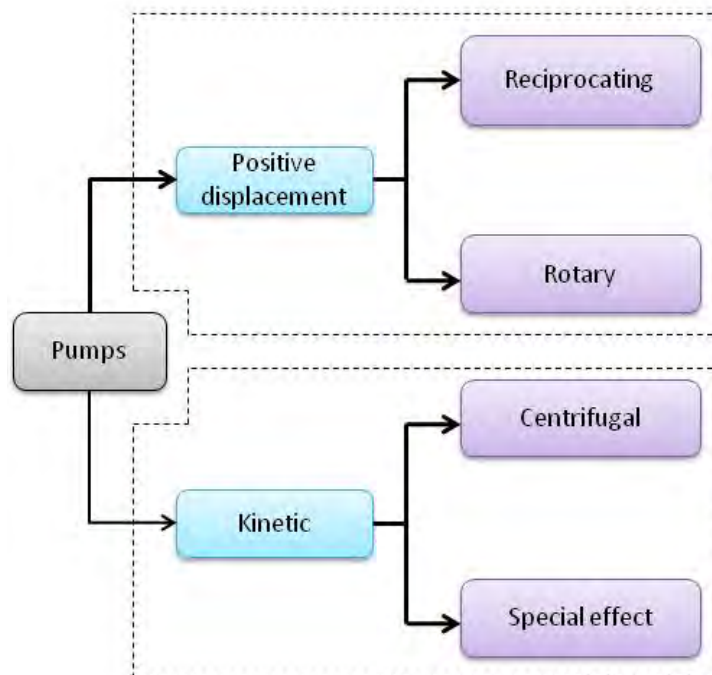

Figure 3.3: Categorization of pump

3.1.3. Centrifugal pumps

The Suction Kit looks and works like a centrifugal pump. A special component obtains the possibility for a reversed flow, the pump itself always has the same rotational direction and nothing is changed in the power transferring component; the impeller. Thus it might be classified as a special effect pump. Nonetheless, the theory regarding centrifugal pumps also applies for this Suction Kit in most cases.

A centrifugal pump is a rotating flow machine in which a high speed impeller transfers mechanical work to the fluid. The transfer of energy ends when the fluid leaves the impeller blade. The fluid velocity and pressure energy has then increased. The velocity energy is again transformed to pressure energy before exiting the pump.

All centrifugal pumps these days have diffusers. The diffuser can increase a pumps efficiency by as much as 3-10%. The diffuser is designed based on the pumps flow rate, Head and RPM to achieve the best efficiency[6]. However, the Suction Kit covered in this thesis does not have a diffuser. The exact reason for this is not known. Most likely it is because a compact

and simple design was needed, by the penalty of reduced efficiency. Another explanation could be that the original design is based on a limited understanding of efficient pump design.

3.2. Blade angles influence on degree of reaction

To find how different blade angles influence a pumps degree of reaction we can compare different velocity triangles for different blade angles, β_2 (see Figure 3.4). Rpm, inlet and outlet diameter and absolute inlet velocity, c_1 , are constant in all cases.

We also assume that c_1 is oriented in a radial direction; we have that $c_{1u} = 0$.

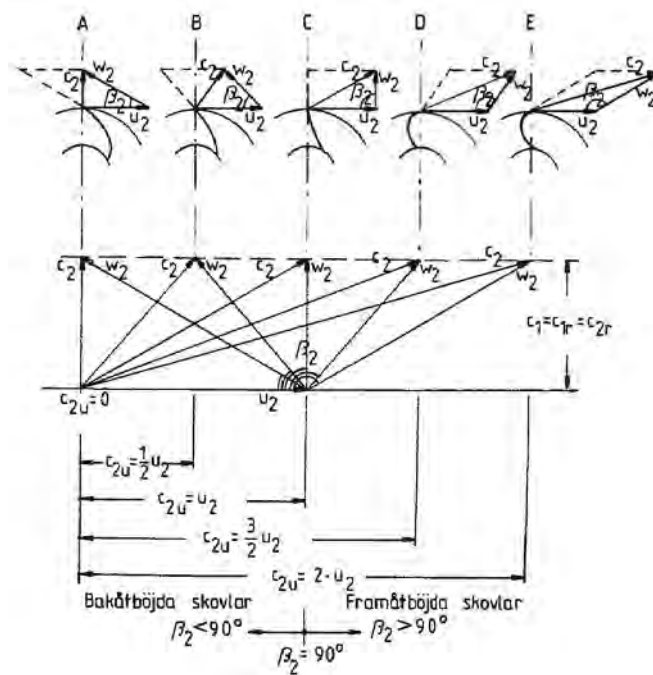

Figure 3.4: Different velocity triangles for different values of impeller blades.[7]

The pressure change in the impeller is defined by the fluids

total pressure

$$\Delta p_t = \rho \cdot u_2 \cdot c_{2u}$$

dynamic pressure

$$\Delta p_d = \frac{\rho}{2}(c_2^2 - c_1^2) = \frac{\rho}{2}c_{2u}^2 = \Delta p_t \cdot \frac{c_{2u}}{2 \cdot u_2}$$

static pressure

$$\Delta p_s = \Delta p_t - \Delta p_d$$

the pumps degree of reaction

$$R = \frac{\Delta p_s}{\Delta p_t}$$

for the given examples of blades (A-E).

The total increase in pressure, Δp_t , is a measure of the pumps power input given other values constant.

From Table 1 we can see that forward bent blades give us the largest increase in total pressure, Δp_t .

Skovel-form	c_{2u}	Δp_t	Δp_d	Δp_s	R
A	0	0	0	0	1
B	$\frac{1}{2} \cdot u_2$	$\frac{1}{2} \cdot u_2^2 \cdot \rho$	$\frac{1}{8} \cdot u_2^2 \cdot \rho = \frac{1}{4} \cdot \Delta p_t$	$\frac{3}{4} \cdot \Delta p_t$	$\frac{3}{4}$
C	u_2	$u_2^2 \cdot \rho$	$\frac{1}{2} \cdot u_2^2 \cdot \rho = \frac{1}{2} \cdot \Delta p_t$	$\frac{1}{2} \cdot \Delta p_t$	$\frac{1}{2}$
D	$\frac{3}{2} \cdot u_2$	$\frac{3}{2} \cdot u_2^2 \cdot \rho$	$\frac{9}{8} \cdot u_2^2 \cdot \rho = \frac{3}{4} \cdot \Delta p_t$	$\frac{1}{4} \cdot \Delta p_t$	$\frac{1}{4}$
E	$2 \cdot u_2$	$2 \cdot u_2^2 \cdot \rho$	$2 \cdot u_2^2 \cdot \rho = \Delta p_t$	0	0

Table 1: Showing the results for different angles for different impeller blades.[7]

However, most of this increase in pressure consists of dynamic pressure. As the Suction Kit covered in this thesis do not have a diffuser this conversion does not happen at all. The conversion of kinetic pressure at the impellers outlet to static pressure happens with high loss. In the Suction Kit we also already have a bad flow path already causing a high pressure loss. This is the reason why the degree of reaction gets worse for forward bent blades than for backward bent blades. The best pump efficiency is achieved for values of $\beta_2 \approx 15^\circ$ –

30°. [7]

3.3. General components of Centrifugal pumps

3.3.1. Casing

The casing of a centrifugal pump provides a pressure boundary for the pump and contains channels to properly direct the suction and discharge flow. The impeller is fitted inside the casing. Generally the casing is one of two types; volute or circular. [12]

Volute Casing

Volute casing build a higher head while *circular casings* are used for low head and high capacity. A volute is a curved funnel increasing in area to the discharge port (see Figure 3.5). The increase in area is to compensate for increasing mass flow out of the impeller.



Figure 3.5: Volute casing. The cross section area is gradually expanding towards the outlet.

Circular Casing

The difference between a *volute* and a *circular* casing is that the cross-section area is constant in a *circular casing*. In addition the losses are higher due to mixed flow and friction due to higher velocity.

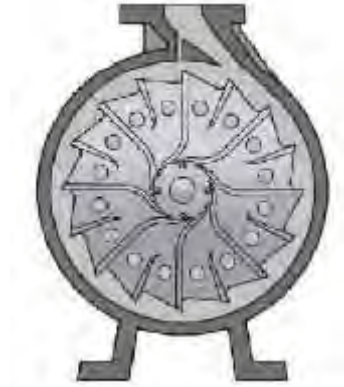

Figure 3.6: Circular casing. You can see that the cross section area is constant[8].

3.3.2. Seal Chamber and Stuffing Box

Seal Chamber and Stuffing Box both refer to a chamber, either integral with or separate from the pump case housing that forms the region between the shaft and casing where sealing components are installed. When the sealing is achieved by means of a mechanical seal, the chamber is commonly referred to as a Seal Chamber. When the sealing is achieved by means of packing, the chamber is referred to as a Stuffing Box. Both the Seal Chamber and the Stuffing Box have the primary function of protecting the pump against leakage at the point where the shaft passes out through the pump pressure casing.[12]

3.3.3. Impeller

The impeller is the main rotating part that provides the transfer of power from the mechanical drive to the fluid resulting in the increase in pressure. They can be classified in many ways. Based on major direction of flow in reference to the axis of rotation:

- Radial flow
- Axial flow
- Mixed flow

Based on mechanical construction:

- Closed; Shrouds or sidewall enclosing the vanes.
- Open; No shrouds or wall to enclose the vanes.
- Semi-open/vortex type

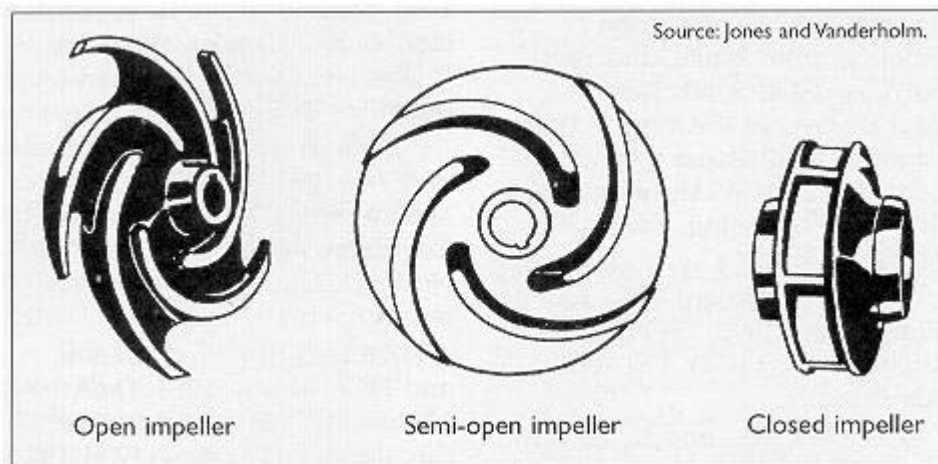

Figure 3.7: Common types of impellers for centrifugal pumps.

Closed impellers are likely to clog in thicker fluids and if the flow contains debris. It also requires wear rings which present a maintenance problem. But they might also be more efficient as the tip gap losses are reduced compared to open and semi-open impellers.[12]

Open and semi-open impellers are less likely to clog, but need manual adjustment to the volute or back-plate to get the proper impeller setting and reduce internal re-circulation.[9]

3.4. Various aspects of pumps

3.4.1. Capacity

The volume of liquid pumped is referred to as capacity. It is usually measured in liters per minute (lpm) or gallons per minute (gpm). Large capacities are frequently stated in cubic feet per second, or millions of gallons per day[10]. The capacity depends on a number of factors, e.g.:

- Liquid characteristics i.e. density, viscosity
- Size of inlet and outlet sections of the pump
- Size of impeller
- Rotational speed of impeller; RPM

3.4.2. Head

Head is a measurement of the height of a liquid column that the pump could create from the kinetic energy imparted to the liquid. Imagine a pipe shooting a jet of water straight up into the air, the height the water goes up would be the head.

Head is often confused with pressure. The difference is that the pressure from a pump will change if the specific gravity (weight) of the liquid changes (significantly), but the head will not change.[11]

3.4.3. Efficiency

Also referred to as *pump efficiency*. The degree of hydraulic and mechanical perfection of a pump is judged by its efficiency. This is defined as a ratio of pump energy output to the energy input applied to the pump shaft. The latter is the same as the driver's output and is termed brake horsepower (bhp), as it is generally determined by a brake test.[10]

In a less complex way you can say that the efficiency is the amount of work we get out of a pump compared to the amount of work we put into the pump.

We have the following expression for the pump efficiency:

$$e = \frac{\text{pump output}}{\text{bhp}}$$

$$= \frac{Q\gamma H}{550 \cdot \text{bhp}}$$

Where

Q is capacity in cubic feet per second

γ is specific weight of the liquid

It may be considered by some that to operate a pump at max speed will be the best for achieving a maximum flow rate and Head. However, a centrifugal pump is normally most efficient in the region between max and 50% rpm, as can be seen in the test done with the Suction Kit (see Test 1 to Test 9). This is also the reason why pump charts and performance curves are very valuable for a pump operator or when someone is to analyze a pump.

3.4.4. Cavitation

Inadequate NPSHa establishes favorable conditions for cavitation in the pump. If the pressure inside the pump falls below the vapor pressure of the fluid, then the cavitation starts. To avoid cavitation, the NPSHr must be larger than the NPSHa;

$$NPSHa < NPSHr$$

Net Positive Suction Head, NPSH, is what the pump needs, the minimum requirement to perform its duties. NPSH is what happens in the suction side of the pump, including what

goes on in the eye of the impeller. NPSH takes into consideration the suction piping, connections, the elevation, absolute pressure of the fluid in the suction piping, the velocity of the fluid and the temperature. You can say that some of these factors add energy to the fluids as it moves into the pump and others subtract energy from the fluid. There must be sufficient energy in the fluid for the impeller to convert this energy into pressure and flow. If the energy is inadequate we say that the pump suffers inadequate NPSH and cavitation might start. NPSHa is the Net Positive Suction Head available in the system, NPSHr is the Net Positive Suction Head required in the system.

It is usually common to say that the pump is exposed to cavitation, although the pump does not really cavitate. It would be more correct to say that the pump is suffering cavitation. In reality it is the system that cavitates the pump, because the system controls the pump. There are five recognized types of cavitation:

- Vaporization cavitation (inadequate NPSHa cavitation)
- Internal re-circulation cavitation
- Vane passing syndrome cavitation
- Air aspiration cavitation
- Turbulence cavitation

Vaporization cavitation represents about 70% of all cavitation.

The Suction Kit is always submerged while operating, the inlet is short and the pressure will usually be greater outside the pump than inside. Because of these factors cavitation is not likely to occur in the Suction Kit.

However, you could expect that the pump cannot provide the mass flow at higher rpm's due to large pressure loss, high flow resistance in the system and turbulence, thus we say that the power is dissipated. It can also be expected that some cavitation might occur locally on the impeller wheel, as the relative movement between fluid and impeller increases.[11]

3.4.5. Affinity laws

The affinity laws express the mathematical relationship between the several variables involved in pump performance. They apply to all types of centrifugal and axial flow pumps. However, they are usually used for smaller changes of flow rate than what is relevant in this thesis. In addition this is only valid for a system without pressure loss, flow resistance or any kind of choking. The affinity laws can be used for systems that are not at the max limit of its performance. As we in this thesis are trying to increase the flow rate and are at the limit of the Suction Kits performance, these formulas don't apply for this system. They can nonetheless be used as a comparison of this Suction Kits performance when looking at the graphs provided from the different tests.

They are expressed as follows:

1. With impeller diameter D held constant:

A. $\frac{Q_1}{Q_2} = \frac{n_1}{n_2}$

B. $\frac{H_1}{H_2} = \frac{n_1^2}{n_2^2}$

C. $\frac{P_1}{P_2} = \frac{n_1^3}{n_2^3}$

Where:

Q = capacity, LPM

H = total head, meter

P = power

N = Pump speed, RPM

2. With speed N held constant:

A. $\frac{Q_1}{Q_2} = \frac{D_1}{D_2}$

B. $\frac{H_1}{H_2} = \frac{D_1^2}{D_2^2}$

C. $\frac{P_1}{P_2} = \frac{D_1^3}{D_2^3}$

When the performance (Q_1 , H_1 or/and P_1) is known at some particular speed (N_1) or diameter (D_1) the formulas can be used to estimate the performance (Q_2 , H_2 or/and P_2) at some other speed (N_2) or diameter (D_2). The efficiency remains nearly constant for speed changes and for small changes in impeller diameter.[13]

As an example, the relation between flow rate and RPM's is usually said to be proportional. That means that if the RPM's is doubled, the flow rate should be doubled. This can be proven by using the affinity laws:

$$\frac{Q_1}{Q_2} = \frac{n_1}{n_2}$$

Where

Q = flow rate

n = RPM

If we double the RPM's we get

$$\frac{n_1}{n_2} = \frac{1}{2}$$

Thus

$$\frac{Q_1}{Q_2} = \frac{1}{2}$$

Which gives

$$Q_1 = \frac{Q_2}{2} \text{ and } Q_2 = 2 \cdot Q_1$$

This proves that the relation between RPM and flow rate is proportional for a perfect case without loss or resistance.

3.4.6. Pressure loss

In a pipe; a closed channel, the fluid flowing is filling the whole cross section area. This means that the fluid doesn't have any free surfaces. The pressure of the fluid is varying along the pipe. The pressure can be higher or lower than the atmospheric pressure.

By using Bernoulli's equation between two points in a pipe, assuming that no energy is added or removed from the flow between these two points, the pressure potential and velocity energy is constant. However, if the flow loses some of its energy; this could be due to a small leakage, internally or externally, flow resistance due to friction, shape of pipe etc. among other things, the total sum of the three mentioned energies will be lower in point 2, than in point 1.

The Bernoulli's equation with pressure loss; Δp_{f12} , can be written:

$$p_1 + \rho \cdot g \cdot h_1 + \frac{c_1^2}{2} \rho = p_2 + \rho \cdot g \cdot h_2 + \frac{c_2^2}{2} \rho + \Delta p_{f12}$$

Where:

Δp_{f12} = pressure loss between point 1 and 2

ρ = fluid density

g = gravitational force

h = geometrical height over a selected point

c = velocity

The expression for the pressure loss;

$$\Delta p_{f12} = \left(p_1 + \rho \cdot g \cdot h_1 + \frac{c_1^2}{2} \rho \right) - \left(p_2 + \rho \cdot g \cdot h_2 + \frac{c_2^2}{2} \rho \right)$$

If the two points, 1 and 2, are at the same height the expression can be written;

$$\Delta p_{f12} = p_1 + \frac{c_1^2}{2} \rho - \left(p_2 + \frac{c_2^2}{2} \rho \right)$$

Because the nozzle must be operated by the ROV's arm which has a limited motion in the vertical direction, the height difference is so small that it can be neglected. We then have that the expression for pressure loss in the Suction Kit is the same as mentioned above.[7]

The case mentioned above is a method used to calculate pressure losses between two given points. When the intention is to calculate pressure losses in design cases e.g. pipe bends,

change in flow areas etc. the formula below is more commonly used, where the pressure loss is expressed as a function of the loss coefficient, density and velocity.

:

$$\Delta p = \xi \rho \frac{v^2}{2}$$

Where

Δp = pressure loss

ξ = loss coefficient

ρ = density

v = velocity

A challenge in this thesis is that when the flow rate is increased, while the flow areas are kept constant (primarily inlet and outlet), the pressure losses will drastically increase.

Consequently the doubling of velocity, from v to $2v$, will increase the pressure loss by 4, as long as the flow areas, in terms of dimension and shape, are kept constant.

3.5. Problems and wear

As the pump performs its duties over time and fluid passes through the pump, erosion and abrasive action will cause the close tolerance parts to wear. These parts may be piston rings, reciprocating rod seals, a flexing diaphragm or meshed gear teeth etc. As these parts wear the pump will lose efficiency and as a result it will no longer build up the required pressure, mass flow etc. When the pumps efficiency drops below a preset level, these parts must be replaced.[11]

There are three types of problems that mostly encounter with centrifugal pumps[12]:

1. Design errors
2. Poor operation
3. Poor maintenance practices

Pumps are often delivered to a workshop with “errors” when in fact the problem is that the operator doesn’t have sufficient knowledge of the pump or doesn’t understand pumps well enough[11]. Pumps and the theory of pumps is complex. Performing calculations regarding this theory is often laborious and must often be based on a number of assumptions.

When trying to locate parts causing decreased efficiency in a pump, it can often seem to be caused by only one part. However, in reality it might be several parts that together are causing the drop in efficiency. In other cases, problems caused by one part might affect the pump in a way that it seems to be caused by a totally different part.

4. Info about the Suction Kit

4.1. General

The suction Kit is designed and developed by the DTS tooling department at Oceaneering A/S and mounted in the workshop (see Figure 4.2 and 4.3). The parts are individually drawn and designed before being ordered in from different manufacturers. Finally it is assembled in the workshop by Oceaneering personnel as can be seen in Figure 4.1.

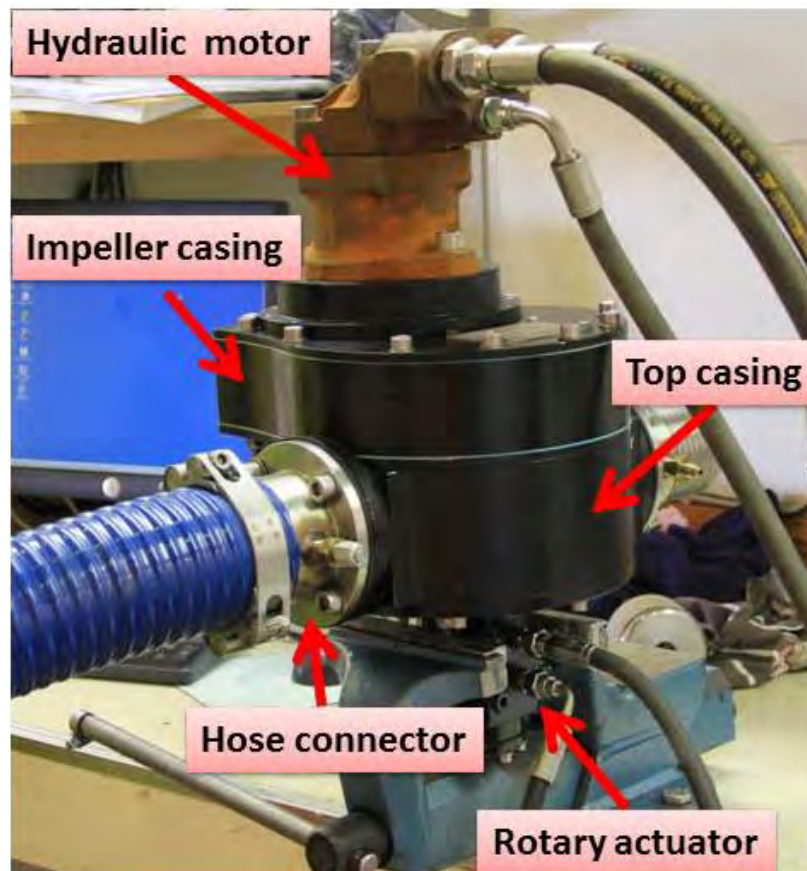

Figure 4.1: A fully assembled Suction Kit



Figure 4.2: Illustration of Suction Kit

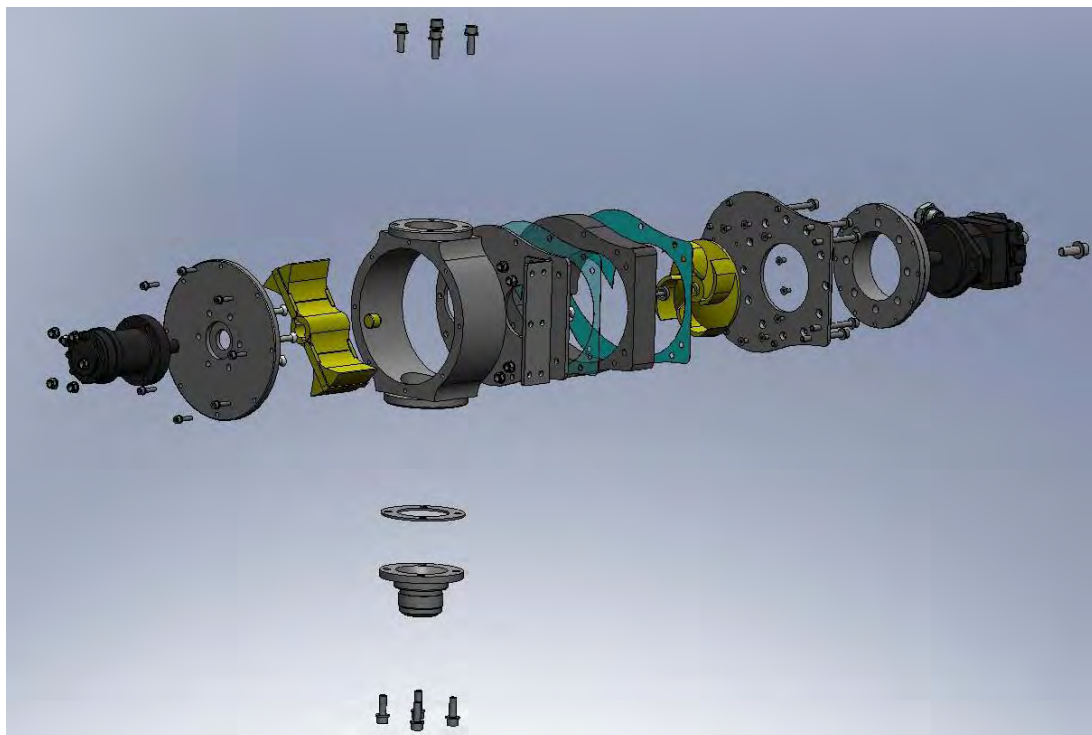

Figure 4.3: Exploded view of a Suction Kit

The Suction Kit has an impeller casing without a properly designed volute. A properly made volute will reduce the speed of the liquid and increase the pressure towards the outlet. However, the poor design of this casing reduces the real effect that a well-designed volute would give significantly. This is because the channel is too narrow and the wall of the casing is too close to the impeller. This is significantly reducing the effect of the pump. In the marked area shown on Figure 4.4 there will be much turbulence. In this area the impeller is therefore whisking the water, not moving it. This also means that in the rest of the volute there should be more distance between the impeller and the wall of the casing to improve the effect.

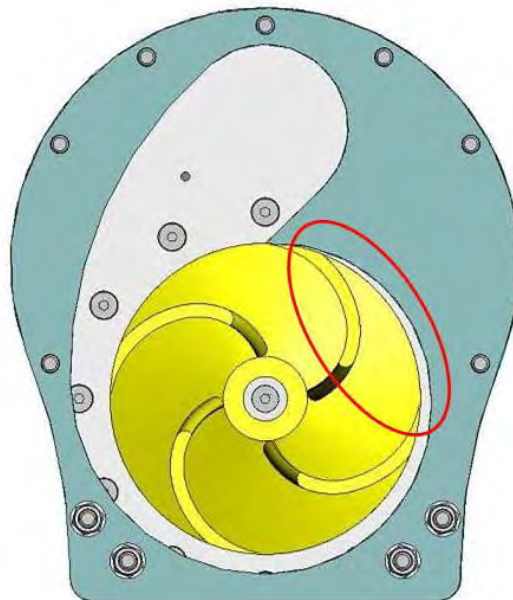

Figure 4.4: Illustration of the impeller

The Suction Kit uses a semi-open impeller which is less likely to clog if the water entering the pump should contain silt and debris. The impeller has a good design regarding angles, number and thickness of the blades. Changing the design would in most cases give small changes to the flow rate. *Impeller 2* can be seen in Figure 4.5.



Figure 4.5: Impeller 2

The inlet and outlet flanges were originally fitted with a 3" to 2" reducer and a 2" hose connection, providing high resistance. This means that a change to 3" hose connections for the inlet and outlet can be easily implemented.

A flow regulator (see Figure 4.1) is used to set the direction of the flow. The design of the flow regulator has probably been intended to be hydrodynamic. However, it is creating a poor flow regime and increased turbulence.

The motor driving the impeller is a hydraulic Volvo motor (F11-010-MB-CN-K-KWK-1060), produced by Parker. Specifications of the motor can be seen in Table 2.

Frame size F11	-5	-6	-10	-12	-14	-19
Displacement [cm ³ /rev]	4.9	6.0	9.8	12.5	14.3	19.0
Operating pressure						
max intermittent ¹⁾ [bar]	420					420
max continuous [bar]	350					350
Motor operating speed [rpm]						
max intermittent ¹⁾	14 000	11 200	11 200	10 300	9 900	8 900
max continuous	12 800	10 200	10 200	9 400	9 000	8 100
min continuous	50					50
Max pump selfpriming speed²⁾						
L or R function; max [rpm]	4 600	–	4 200	3 900	3 900	3 500
Motor input flow						
max intermittent ¹⁾ [l/min]	69	67	110	129	142	169
max continuous [l/min]	63	61	100	118	129	154
Main circuit temp.³⁾, max [°C]	80					80
min [°C]	-40					-40
Theoretical torque at 100 bar [Nm]	7.8	9.5	15.6	19.8	22.7	30.2
Mass moment of inertia (x10 ⁻³) [kg m ²]	0.16	0.39	0.39	0.40	0.42	1.1
Weight [kg]	4.7	7.5	7.5	8.2	8.3	11

Table 2: Specifications of the original motor used in the Suction Kit.

4.2. Evaluation of the Suction Kit

The Suction Kit differs from a standard design of centrifugal pumps, especially regarding the flow path of the water between inlet and outlet. However, this routing of the water is incorporated to obtain a reversible function of the pump. The concept of the Suction Kit is rather simple, but as a consequence the pump efficiency is reduced. An example of this can be seen from test 7 and 8, where the flow rate is increased drastically by removing the top casing.

Important factors for a pump of this type and service are:

- Head
- Capacity
- Ease of operation
- Efficiency
- Size and weight
- Dependability
- Maintainability
- Durability

4.2.1. Head

Although the Head usually is an important and often focused parameter and term for pumps, it is not relevant for the Suction Kit. This is because the specification from Statoil only calls for 250 kPa (36 psi = approx. 2,5 bar) over/under pressure. Further it is usually operated with small elevation differences between inlet and outlet.

4.2.2. Capacity

Capacity is a vital parameter in this thesis. The main challenge for this Suction Kit is to reach the specified flow required by Statoil. Capacity is further defined under in chapter “3.2 Various aspects of pumps”.

4.2.3. Ease of operation

The design of the Suction Kit enables a fairly easy operation requiring only hydraulic power to the motor and a hydraulic supply to control the flow regulator. The 3" hose might be somewhat awkward to handle, but there are not many options in that regard. The size of the hose is much decided on required flow rate, minimizing the flow resistance and the resistance against collapse during suction operations.

4.2.4. Efficiency

The efficiency of the Suction Kit is deemed to be poor. The main reason for this is the hydrodynamic design facilitating many sharp bends and changes in flow area and volumes. In addition the internal design of the impeller casing leading the water from the impeller is not optimal for its purpose. This is because the funnel, being too narrow along the circumference of the impeller, is creating turbulence and an inefficient flow regime.

4.2.5. Size and weight

Size and weight are important factors for ROV mounted equipment due to the need for compact and smooth operations and handling. Often an ROV has to operate in confined space. Very often the ROV has to perform work inside subsea structures and production templates providing little space and room for maneuvering. An ROV has a limited payload and available volume for extra equipment. The Suction Kit provided by DTS is fairly compact and should be ok. The weight of the Suction Kit in air is fair (24kg). Buoyancy elements installed on the ROV counteract the weight in water but increases the handling weight above surface. The weight is therefore acceptable compared to the performance.

4.2.6. Dependability

It is very important for equipment like this to be robust and durable. If the Suction Kit fails while operating in a critical phase in deeper water, the entire operation, e.g. a completion operation encompassing installation of a BOP stack, have to be halted while the ROV is recovered to surface for repair or replacement of the Suction Kit. In deeper water the time to recover and launch the ROV is time and cost demanding. The Suction Kit in question is fairly simple, but still there is an extra hydraulic function for the flow regulator. The risk of jamming this is present, but deemed to be low and acceptable.

4.2.7. Maintainability

The Suction Kit consists of relatively few parts. Assembling and disassembling is easy, and most of the parts can be mounted or replaced with little time and effort. There are no parts requiring fine tuning and adjustments except for the flow regulator. This device requires some adjustments to ensure that it do not block the inlet/outlet.

The original impeller casing design does allow for a wrong assembly causing malfunction and significantly reduced capacity. For inexperienced personnel in a stressed situation during a repair on deck, there is a certain possibility of wrong doing. This can be quite time and cost consuming if not detected prior to launching.

4.3. Range of applications

The Suction Kit is an important tool and is very often mounted on the ROV. It can be used to remove silt, debris or other particles that prevent the ROV from completing a task and/or are limiting the performance of an operation. The Suction Kit can also be used when vacuum anchors (suction anchors) are to be deployed.

During certain operations the ROV needs to ensure a stable working situation to complete a given task. This could be due to strong currents or a task that demands high precision. The ROV then needs to hold on to a surrounding structure. This can be achieved with the Suction Kit by using suction cups, which is a possible accessory[14].

4.4. Flow path

When the Suction Kit starts to operate, water is sucked through the inlet towards the impeller as can be seen in Figure 4.6. As the water is entering the impeller and moving outwards, kinetic energy is added. After exiting the impeller blades (see Figure 4.7) the water continues through the impeller casing before, after several sharp and pressure loss creating turns, it enters the top casing. This is where the flow regulator is located. After entering the top casing, the water flows towards the outlet, before exiting the pump. This can be seen in Figure 4.8.

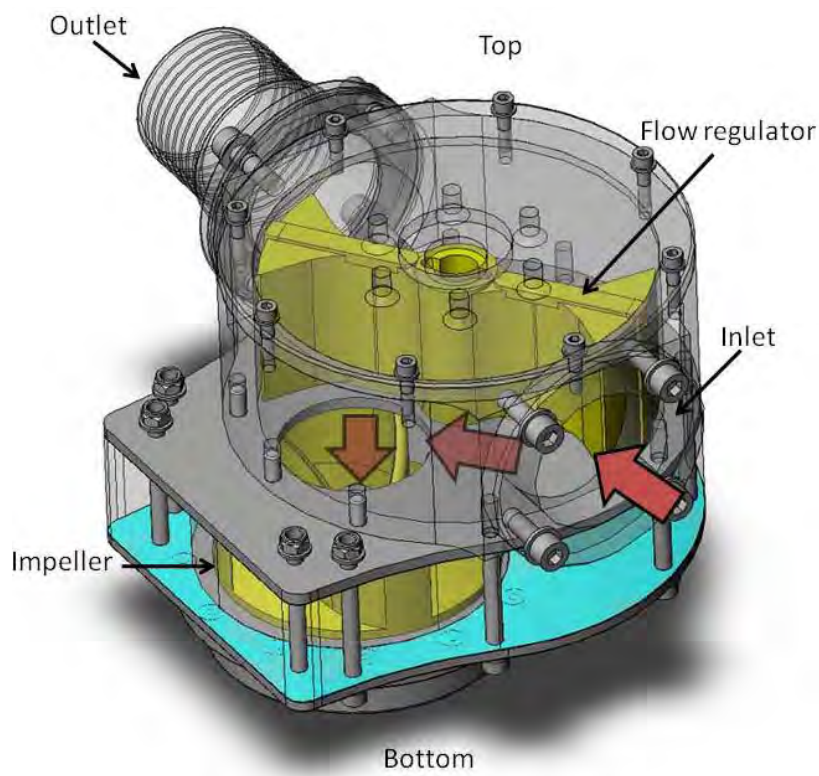

Figure 4.6: Flow path. The red arrows illustrate the direction of the flow. The Suction Kit seen from the top. The impeller can be seen in yellow at the bottom of the picture. The flow regulator can be seen at the top.

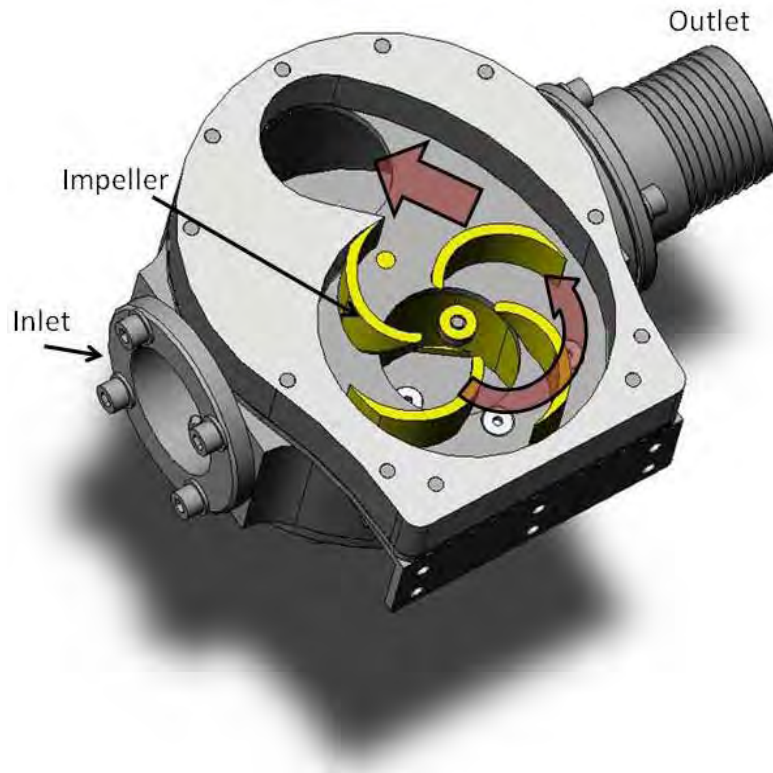

Figure 4.7: The red arrows illustrate the direction of the flow. The Suction Kit, viewed from the bottom, showing the cross section of the impeller casing and impeller.

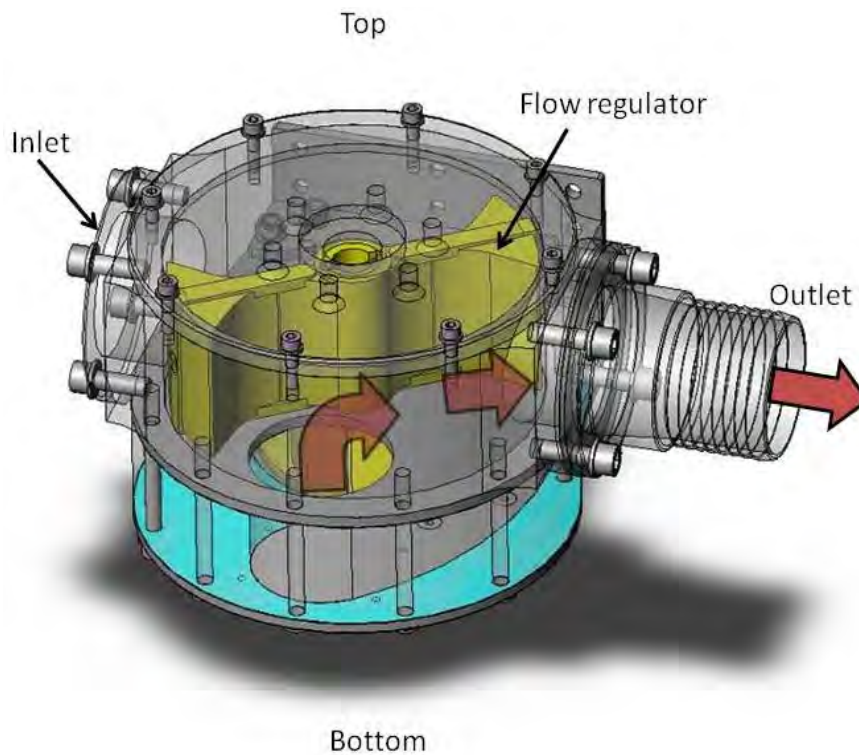

Figure 4.8: Flow path. The red arrows illustrate the direction of the flow. The Suction Kit viewed from the top. The impeller is barely visible below the flow regulator.

4.5. Reversible function

The reversible mode works by activating the rotary actuator mounted on the top casing by applying hydraulic pressure. When activated, the rotary actuator makes the flow regulator turn 90° counterclockwise as illustrated in Figure 4.9. This action will reverse the flow and thus make the outlet (see Figure 4.6-4.8) become inlet, and inlet will become outlet. However, the impeller does not change direction and is always rotating the same way.

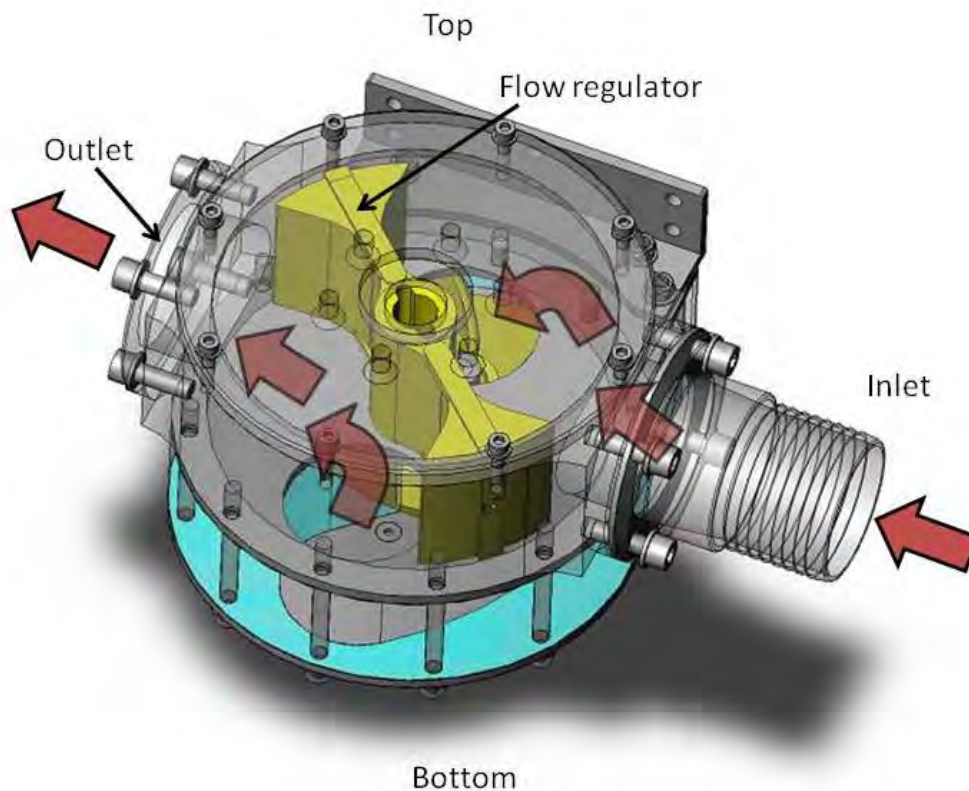

Figure 4.9: The flow regulator has been turned 90° counterclockwise, reversing the flow.

If the hose and nozzle are installed on the hose connector seen to the right in Figure 4.9, and the flow regulator is in the same position, the Suction Kit is sucking. If the flow regulator is rotated to its other position (as can be seen in Figure 4.6 and 4.8), the Suction Kit is blowing.

5. What influences the flow rate?

5.1. General

If a specific part or the whole pump does not have an optimal design, this could clearly affect the flow rate in a negative direction. However, in this chapter it is focused on factors that will influence flow rate, given that the existing design is optimized.

5.2. Pump charts

Pump charts should always follow a pump. There are a number of varieties of different curves and charts showing different aspects of a pumps performance and operation. By using this documentation it is possible to better understand, maintain and supervise a pump. Some of these charts can be used to determine a specific value of flow rate at a specific value of another parameter, e.g. Head as can be seen in Figure 5.1 below.

The figure below shows an example of a pump chart. It is a performance chart that shows the flow rate versus Head. It shows this at constant speed for different models of a centrifugal pump. Note that as the Head decrease, the flow rate increase and vice versa.

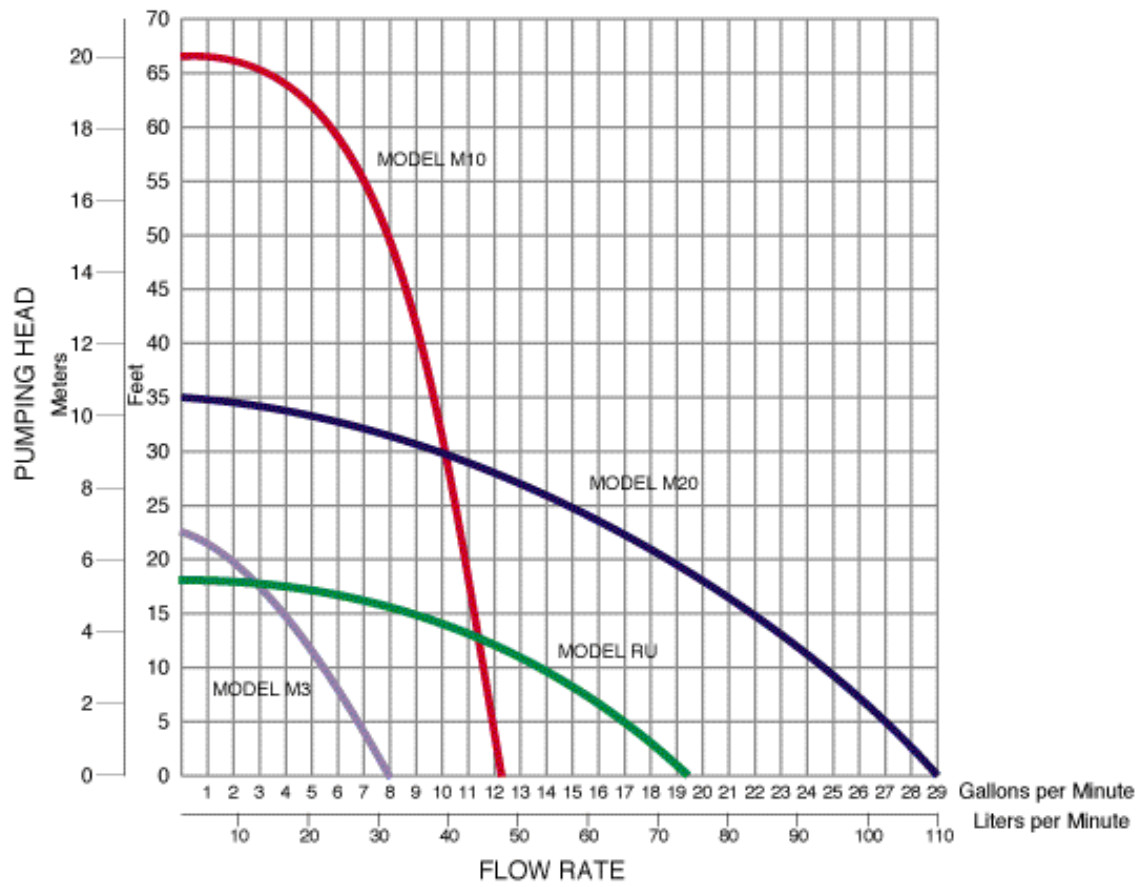

Figure 5.1: Pump chart for different models of a centrifugal pump.

5.3. Theoretical assessment

The volumetric flow rate; Q , in fluid dynamics and hydrometry is the volume of fluid which passes through a given surface per unit time.

Flow rate is usually calculated at a point before the flow enters the impeller, often at the inlet. The flow rate can also be calculated from the impeller, but this is more complicated.

We can write the volumetric flow that flows through the inlet as a product of the area, A , of the inlet times the velocity of the fluid, c , perpendicular to the area.

We get the following expression

$$Q = A \cdot c \cdot \cos \theta \quad (1)$$

where

$\cos \theta$ is the angle of the velocity away from the perpendicular direction on the area.[15]

The expression for flow rate calculated from the impeller is more complex. It is written as the product of the impeller inlet area (alternatively outlet area), D , times the fluids velocity, c , perpendicular to the respective area (see Figure 5.3), and the width of the blades, b . The areas mentioned consist of cylindrical surfaces with diameter D_1 and D_2 .

The expression for the volumetric flow can thus be written

$$Q = \pi \cdot D_1 \cdot b_1 \cdot c_{1r} = \pi \cdot D_2 \cdot b_2 \cdot c_{2r} \quad (2)$$

where

D_1 and D_2 = the impeller blades inlet and outlet diameter.

For other designations see Figure 5.2.

This is a more laborious method to calculate the flow rate, especially if you are not familiar with velocity triangles, relative and absolute flow systems etc. The equation based on inlet area might be preferable if this is the case.

Note that the volumetric flow delivered by the pump is not affected by the type of fluid that is moved. This can be seen as none of the fluid constants are included in either of the equations (1) or (2). The only constants that affect the flow rate are the area of the flow and the fluid's velocity component perpendicular to the area.

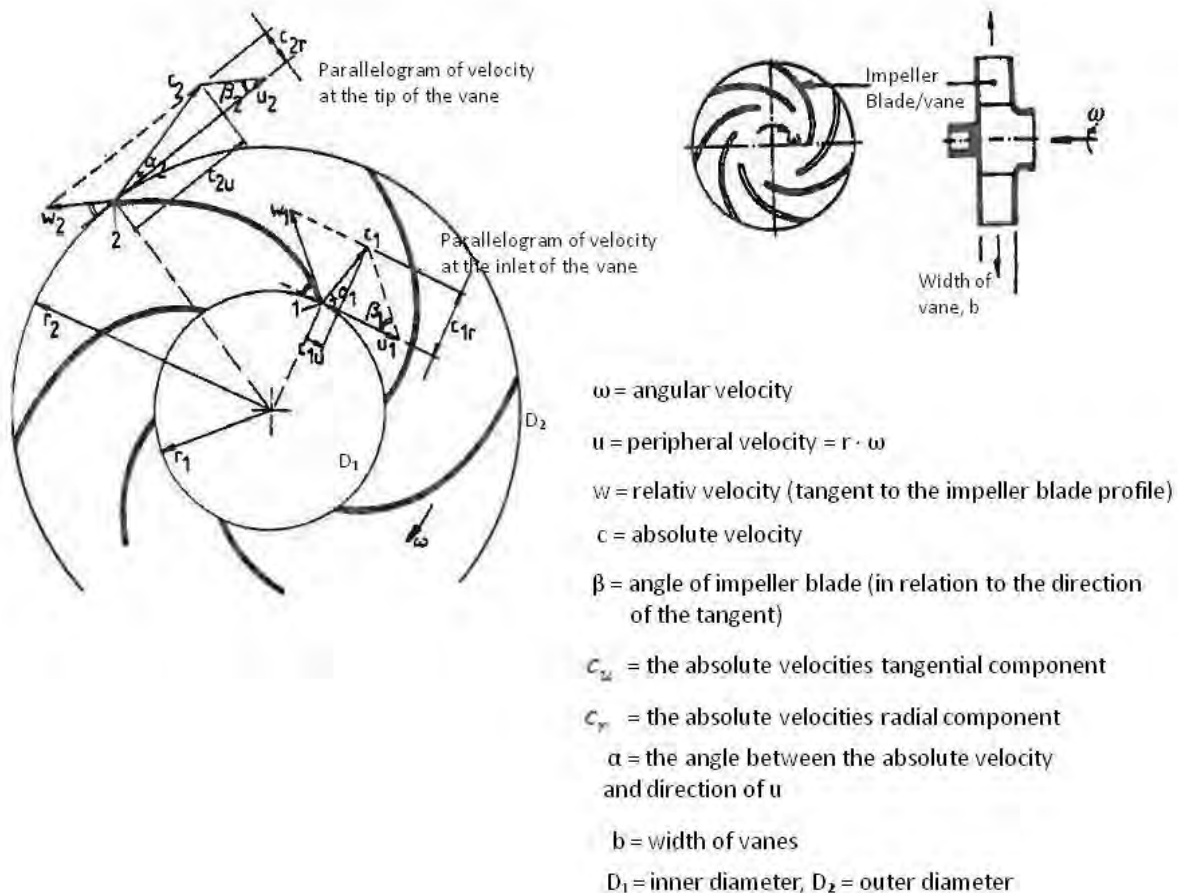

Figure 5.2: Components of velocity in an impeller[7].

Area is mainly given by the height of the impeller blades, inlet and outlet diameter. The velocity is in a perfect case mainly governed by the speed of the driver; the impeller, which is given by the motor. However in this case, as it is assumed that the impeller is whisking the water, it is the velocity of the water flow that affects the flow rate. Other factors, like the number, pitch and thickness of the impeller blades play a lesser role in the pump's flow rate.[11]

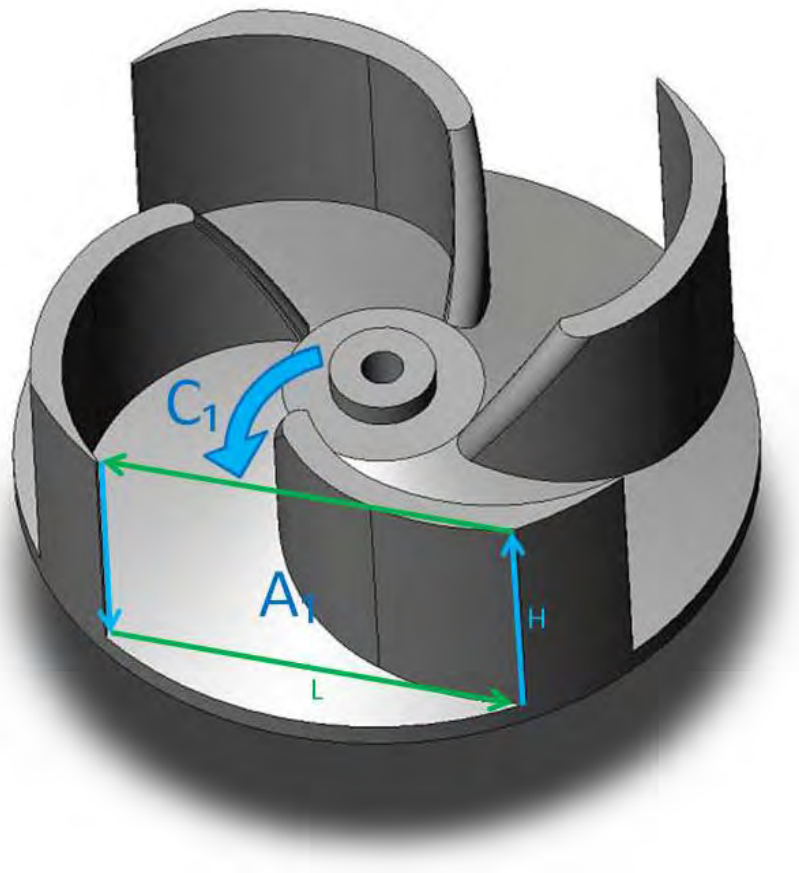

Figure 5.3: Shows an illustration of the impeller. A_1 shows the area, and C_1 shows the direction of the speed.

5.4. Revolutions Per Minute

RPM indicates the speed of the impeller, which is powered by the hydraulic motor. A bigger motor (with respect to cm^3) will at the same hydraulic oil supply rotate at a lower speed. However, the bigger motor will give a higher torque at the same hydraulic oil pressure.

Challenges when increasing the RPM significantly is the increased possibility of turbulence and cavitation. Therefore the inlet and outlet areas should be enlarged if the speed is increased.

5.5. Pressure loss and flow resistance

5.5.1. General

It is important to focus on the hydrodynamic design of a pump to achieve an optimal efficiency. This is because a good hydrodynamic design will minimize turbulence and pressure loss, and ensure a better flow path. In practical terms this implies to avoid abrupt pipe bends, sharp edges, and changes in flow areas and volumes. This can again have great influence on the flow rate, depending on number and severity of these obstacles. Assuming a specific designed pipe bend, the greater angle of change the flow in this bend is exposed to, the more pressure is lost. The pressure loss is caused by a double vortex that can propagate far past the bend. The best way to cope with this problem is to install vanes in the bend[7].

Pressure loss can also be caused by leakages, i.e. the system is not completely sealed and some of the water finds its way to other places where it's not supposed to be. We also experience pressure losses due to friction. The size of the friction losses depend on the type of material of the different parts, how the material or part has been manufactured and if it has been subjected to any kind of surface treatment, coating etc. This is of importance as different materials have different values of friction.

Usually friction losses are so small that they can be neglected. This is the same for the Suction Kit. The losses inside the Suction Kit are deemed so high due to the design, thus making the friction losses insignificant.

To make a pump more hydrodynamic, it should be designed so that the fluid flows smoothly through the entire system. Use of proper sealing material and ensuring that parts are assembled correctly to avoid leakage is also necessary. In addition, a conscious use of materials for the different parts, e.g. using materials with low surface roughness, and manufacturing techniques will help reducing the friction loss. However, how much effort that is put into reducing friction losses should be looked at for each case.

5.5.2. Resistance coefficients

In Figure 5.4, in the situation far left, the water is guided along the wall until it enters the pipe outlet. In addition, the pipe walls around the pipe outlet are rounded. This gives a smoother transition for the flow, but you still have some pressure loss. In the situation in the middle the walls are guiding the water towards the outlet. However, the wall enters sharply into the pipe. In the situation far right, the water is not guided towards the outlet at all; the outlet is located in the middle of the tank. In this situation you have a very high pressure loss.

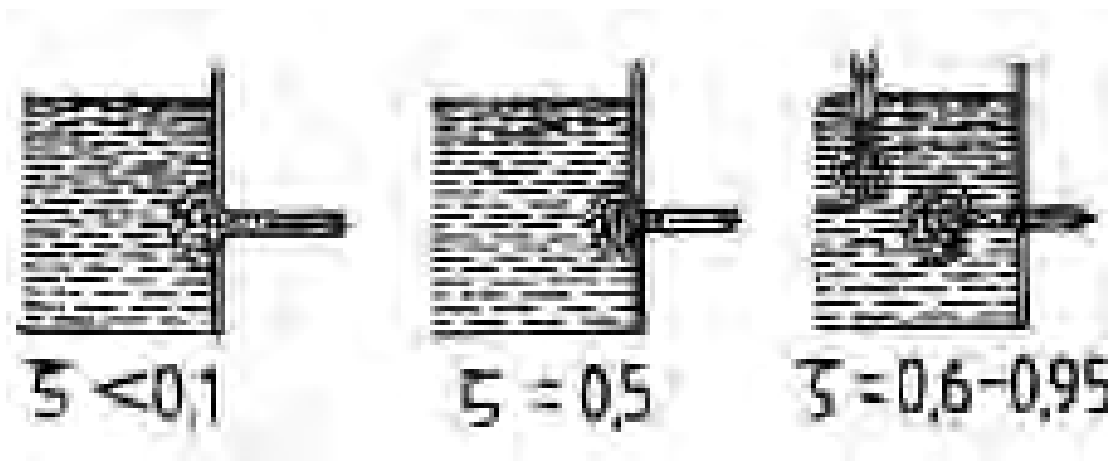

Figure 5.4: Three different situations of pressure loss caused by a sudden change in area of outflow[7].

We can make an assumption of the resistance factor in this system by using I.E. Idelchik's values for resistance factors of different configurations. First we split the system into multiple components, such as bends, changes of flow area etc. We then end up with 5 different components for the flow through the Suction Kit:

1. Water tank \rightarrow Inlet (change of flow area)
2. Inlet \rightarrow top casing (change of flow area)
3. Flow regulator (shape/geometry causing turbulence)
4. Top casing \rightarrow impeller (90° bend and change of flow area)
5. Impeller \rightarrow top casing (90° bend and change of flow area)
6. Top casing \rightarrow outlet (change of flow area)

For component 1, this situation is similar to the one in Figure 5.4 from [7], wide right. The coefficient in this case is $\zeta = 0,6 - 0,95$, further assuming a value of $\zeta = 0,7$.

When the water flows from the inlet to the top casing (component 2), we have a sudden expansion of flow area. A similar situation for a laminar flow has a range of $\zeta = 0,16 - 0,81$. In this Suction Kit we have to expect a high level of turbulence.

From [16-1] we find that:

$$\frac{F_0}{F_2} = \frac{1}{n_{ar}} \rightarrow n_{ar} = \frac{A_1}{A_2}$$

where

$$n_{ar} = \text{degree of enlargement}$$

Assuming top casing is 4,5"=114,3mm. Inlet size is 3"=76,2mm.

$$n_{ar} = \frac{114,3}{76,2} = \frac{3}{2} = 1,5$$

Assuming $m=1$, this gives $\zeta = 1,09$.

The flow regulator in component 3 is assumed to cause increased turbulence and resistance due to its design. This value is estimated to be $\zeta = 0,2$.

From [16-2], assuming the resistance coefficient without the material transported, this gives a factor of $\zeta = 1,14$ for each situation with a 90° bend and change of flow area; situation 4 and 5.

The water flowing from the top casing to the outlet faces a sudden contraction of flow areas (component 6). A square-edged change of flow area, $r = 0$ is assumed. This results in $\frac{r}{D_h} = 0$ which gives $\zeta = 0,5$ [16-3].

Therefore a total resistance coefficient of:

$$\zeta = 0,7 + 1,09 + 0,2 + 1,14 + 1,14 + 0,5 = 4,77$$

Needs to be expected.

This is a very high resistance coefficient, and is due to a significant numbers of changes in geometry and flow directions even higher than the single values above represent.

If we look at how the velocity and flow rate affect pressure loss and vice versa we introduce the following formulas:

$$\frac{\Delta p_{new}}{\Delta p_{original}} = \frac{C_{new}^2}{C_{original}^2} \quad \text{and} \quad \frac{\Delta p_{new}}{\Delta p_{original}} = \frac{Q_{new}^2}{Q_{original}^2}$$

Where,

Δp = pressure loss

C = velocity

Q = flow rate

To demonstrate how these parameters affect each other we assume a required reduction in pressure loss of:

- 25% → 0,75
- 50% → 0,50
- 75% → 0,25

First we reduce pressure loss by 25%:

$$\Delta p_{new} = \Delta p_{original} \cdot 0,75$$

$$\frac{\Delta p_{original} \cdot 0,75}{\Delta p_{original}} = \frac{C_{new}^2}{C_{original}^2} \quad (\text{inserting for } \Delta p_{new})$$

$$\frac{C_{new}^2}{C_{original}^2} = 0,75$$

$$C_{new}^2 = 0,75 \cdot C_{original}^2$$

$$C_{new} = \sqrt{0,75} \cdot C_{original}$$

$$C_{new} = 0,87 \cdot C_{original}$$

If the pressure loss shall be decreased by 25%, the velocity needs to be reduced by 13% ($1 - 0,87 = 13\%$). It also indicates that an increase in velocity by 13%, gives an increase in pressure loss of, $\left(\frac{(1+0,13)^2}{1^2}\right) = 1,277 \approx \underline{27,7\%}$.

Reducing pressure loss by 50%:

$$\Delta p_{new} = \Delta p_{original} \cdot 0,50$$

$$\frac{\Delta p_{original} \cdot 0,50}{\Delta p_{original}} = \frac{C_{new}^2}{C_{original}^2} \quad (\text{inserting for } \Delta p_{new})$$

$$C_{new} = \sqrt{0,50} \cdot C_{original}$$

$$C_{new} = 0,70 \cdot C_{original}$$

An increase in velocity by 30% ($1 - 0,70 = 30\%$), gives an increase in pressure loss of, $\left(\frac{(1+0,30)^2}{1^2}\right) = 1,69 \approx \underline{69\%}$.

Reducing pressure loss by 75%:

$$\Delta p_{new} = \Delta p_{original} \cdot 0,25$$

$$\frac{\Delta p_{original} \cdot 0,75}{\Delta p_{original}} = \frac{C_{new}^2}{C_{original}^2} \quad (\text{inserting for } \Delta p_{new})$$

$$C_{new} = \sqrt{0,25} \cdot C_{original}$$

$$C_{new} = 0,50 \cdot C_{original}$$

An increase in velocity by 50% ($1 - 0,50 = 50\%$), gives an increase in pressure loss of, $\left(\frac{(1+0,5)^2}{1^2}\right) = 2,25 = \underline{125\%}$.

Using these results to find how the pressure loss affects the flow rate we can use the same numbers as the examples above. That means that

$$Q_{new} = 1,277 \cdot Q_{original}$$

$$Q_{new} = 1,69 \cdot Q_{original}$$

$$Q_{new} = 2,25 \cdot Q_{original}$$

The calculations give that if the pressure loss is reduced 25%, the flow rate is increasing 27,7%. In a case where pressure losses are reduced with 50%, the flow rate is increased 69%. If the pressure losses are reduced 75% the flow rate increases 125%.

To achieve the required flow rate in this thesis, it had to be increased 53%. That is approximately 700 lpm. This means that if the pressure losses are reduced 50%, we would have a flow rate of $1320 \cdot 1,69 = 2230,8$ lpm, which is way above the requirement.

6. Improvements

6.1. General

The Suction Kit originally had a flow rate of approximately 1300 lpm, based on Test 1 (see Table 3). The requirements demand a flow rate of at least 2000 liters per minute. This means an increase in flow rate of 700 liters or 53%. In relation to flow rate, a 53% increase is very high and could be difficult to achieve without designing a bigger pump.

A problem that could occur is that when the flow rate is increased, while the flow areas are kept constant (primarily inlet and outlet), the pressure losses will drastically increase as shown earlier in this thesis. Consequently the doubling of velocity, from v to $2v$, will increase the pressure loss by 4, as long as the flow areas, in terms of dimension and shape, are kept constant.

Another factor that could be a problem regarding the flow rate is the non-hydrodynamic design of the Suction Kit. If you look at the way the water need to flow through the pump it is not very efficient. The water should be guided through the pump with a more hydrodynamic design to decrease the flow resistance and minimize pressure loss.

6.2. Definition of parts

To avoid confusion and misunderstandings as some parts are modified or changed during the modification of this Suction Kit, we define the different parts that will be discussed in this chapter.

6.2.1. Motor

The original motor used in this Suction Kit is a 9,8 cm³ hydraulic Volvo motor. This motor is referred to as "*Motor 1*". Some additional info can be earlier in this thesis.

The new motor replacing the original one is a 14,3 cm³ hydraulic motor produced and delivered from the same factory as the original. This motor is referred to as "*motor 2*".

6.2.2. Impeller

The original impeller, made of 316 L stainless steel, has a blade height of 42 mm. This impeller is referred to as “*impeller 1*”.

A new impeller was made to fit the Suction Kit. It was made in the same material, but with a blade height of 57 mm; 15 mm higher than impeller 1. This impeller is referred to as “*impeller 2*”.

Both impellers; 1 and 2, were modified to fit the drive shaft of the new motor. The impellers sockets were machined to a larger diameter to fit the shaft of *Motor 2*. As this is the only modification, the impellers are still referred to as *Impeller 1* and *2*. However, this modification prevents us from re-testing with *Motor 1*, as the impellers don't fit that shaft after being modified.

6.2.3. Casing

The original casing, that fits impeller 1, is referred to as “*Casing 1*”. The casing made to fit *Impeller 2*, is referred to as “*Casing 2*”. The casing that was modified to give the flow a more hydrodynamic path, from the volute to the top casing, is referred to as “*Casing 3*”. Casing 3 is made to fit Impeller 2 and is thus a modification of Casing 2. Casing 2 and 3 can be seen in Figure 6.1 and 6.2.

6.3. Limitations

Oceaneering did not have any specific test procedures for the Suction Kit. Because of the uncertainty with how the testing should be carried out, the test routines and procedures were gradually developed as the tests went on. The routines were also improved and changed as knowledge was gained through trial and error, literature and conversations with people with knowledge of the subject.

This is the reason why the first 3 tests have limited values. At the time these tests were performed it was not seen necessary to obtain values at lower pressure rates from the HPU. However, when better routines were obtained, it was not seen essential to the solving of the problems in this thesis to redo these tests.

The flow rate of 1320 lpm found in Test 1 is set as reference test or base case. This test was performed with Motor, Impeller and Casing 1. It was also performed with a 3" hose connector and hose.

During the tests that were performed in regard to this thesis, there are several sources of error that might have occurred. These could have affected the test results in a negative or positive direction. Some of the sources of error that might impact the results are as follows:

- Temperature of hydraulic oil
- Accuracy of measuring
 - Starting and stopping of the stopwatch
 - Reading of water levels in tanks (due to turbulence/waves? in water)
- Air and turbulence in the flow inside the pump

There might be other sources of error not identified.

The different graphs in this thesis are based on flow rate, Q , measured in LPM and hydraulic pressure provided from the HPU. Hydraulic power shows the power input to the pump from the HPU. As it is possible to read the hydraulic pressure directly from the HPU, it will be easier for Oceaneering personal to identify these numbers than e.g. RPM's that must be

calculated for each test. This is especially important if the documentation from this thesis is to be used during future work with these Suction Kits.

Previous tests of Suction Kits at Oceaneering's workshop have shown some small differences in max capacity in regard to flow rate. Because of this, other Suction Kits might show different values of flow rate if the same modifications are carried out on them.

Some estimations and round offs are made when different results at same hydraulic pressure during tests e.g. the average between two measuring's is written or if one measuring by a number of sources of errors it is not documented at all. Also when percentages of increased flow rate is presented, some estimations and round offs might have been performed to make the numbers add up.

In an effort to obtain inlet/outlet pressure in order to find Δp and prove high pressure losses inside the system, several tests were performed. Both analog and digital manometers were used, in a variety from low to high precision. We also tried to get a reading of the pressure by using a pressure transmitter. It was not possible to get accurate numbers due to high levels of turbulence which was causing inaccurate readings.

Based on the poor results from the attempted pressure measurings performed. In addition to the suspicion that the top casing was causing much of the pressure losses due to the number of sharp turns and changes of flow areas. It was decided to test the Suction Kit without the top casing and flow regulator.

During all the tests performed in this thesis, there were situations where the hose was partly choked in an effort to increase the pressure readings. This gave some unofficial readings that assume that the Suction Kit is well above the requirement of 2,5 bar overpressure and 2,5 bar underpressure. However, the circumstances would not allow this to be a valid test.

6.4. Impact of modifications

6.4.1. Test setup

The original ¼" hydraulic hoses (supertuff 3/8 bsp) delivering hydraulic power from the HPU to the Suction Kit's motor where replaced by ½" hoses (supertuff jic 12) to increase the hydraulic flow to the motor. We also implemented a method to not start the stopwatch before 100 liters had been moved by the Suction Kit. The hose and connector were changed from 2" to 3".

Improvement of modification (with impeller 2 and casing 2):

- 1154 lpm → 1450 lpm (first test → Test 2)

Values from the first tests are seen as unofficial because the test setup and the execution of the tests were not optimized. However it gives an idea on how optimizing the routines and limiting the sources of error might improve the results.

6.4.2. Impeller

When working with improving a pump, it is easy to start to focus on the impeller because this is the only moving part. But under the assumption that the impeller blades are backward bent (see chapter 3.2) and number and thickness of blades are reasonable, other modifications than adjusting the height of the impeller blades will in most cases not influence the flow rate to any great extent.

Before we started to test the Suction Kit, Oceaneering had already ordered in a new impeller and casing, 15mm higher than the original parts. However no testing or documentation had been performed. The parts had been ordered in on the assumption that greater area would give higher flow rate. From equation (1) and (2) we can conclude that this assumption theoretically is correct, as the area is one of the key factors to influence the flow rate.

By changing the impellers (using motor 1 at 200 bar) we got the following increase in flow rate:

- 1320 lpm → **1450 lpm** (Test 1 → Test 2)

With motor 2 at 190 bar we got:

- 1360 lpm → **1460 lpm (at 170 bar)** (Test 3 → Test 4)

The increased height of the impeller gives an increase in flow rate of 130 lpm with motor 1 and 100 lpm with motor 2. If the impeller casing had a better hydrodynamic design, better flow path etc. the impact of this modification might have been higher as it could decrease the level of turbulence, flow resistance and pressure loss.

6.4.3. Motor

After the first couple of tests we only got 30lpm from the HPU through the motor. Suspecting that this was caused by high flow resistance we chose to order in a bigger motor to see if we could get a higher flow rate by forcing the water through the system.

Calculation based on values before and immediately after changing the motor showed an approximately

increase in RPM due to change of motor of:

$$\frac{dm^3}{rev} \cdot \frac{rev}{min} = \text{liter}/min$$

$$\frac{\frac{liter}{min}}{\frac{dm^3}{rev}} = rev/min$$

$$\frac{55 \frac{liter}{min}}{14,3 \cdot 10^{-3} \frac{dm^3}{rev}} = \underline{\underline{3846 \frac{rev}{min}}}$$

The first motor gave:

$$\frac{30 \frac{\text{liter}}{\text{min}}}{9,8 \cdot 10^{-3} \frac{\text{dm}^3}{\text{rev}}} = 3061 \frac{\text{rev}}{\text{min}}$$

This gives an increase in RPM of $3846 - 3061 = 785$ at maximum hydraulic pressure.

The fact that the RPM's were increased is proving the fact that there was high resistance for *Motor 1*. If the resistance had been low or more optimal the max RPM's would have been lower for *Motor 2* than for *Motor 1*.

Change from *Motor 1* to *Motor 2* (using *Impeller 1*) gave the following increase in flow rate:

- 1320 lpm → **1360 lpm** (Test 1 → Test 3)

With *Motor 2* (using *Impeller 2*) we got the following increase:

- 1450 lpm → **1460 lpm (at 170 bar)** (Test 2 → Test 4)

Increasing the power input gave not a big change in max flow rate, but we did increase the lpm from the HPU. This means that the motor is not the problem, we have enough power input.

6.4.4. Impeller casing

A better designed casing could improve the flow from the impeller casing to the top casing, as the channel leading from the impeller ends in a wall (see Figure 6.1).

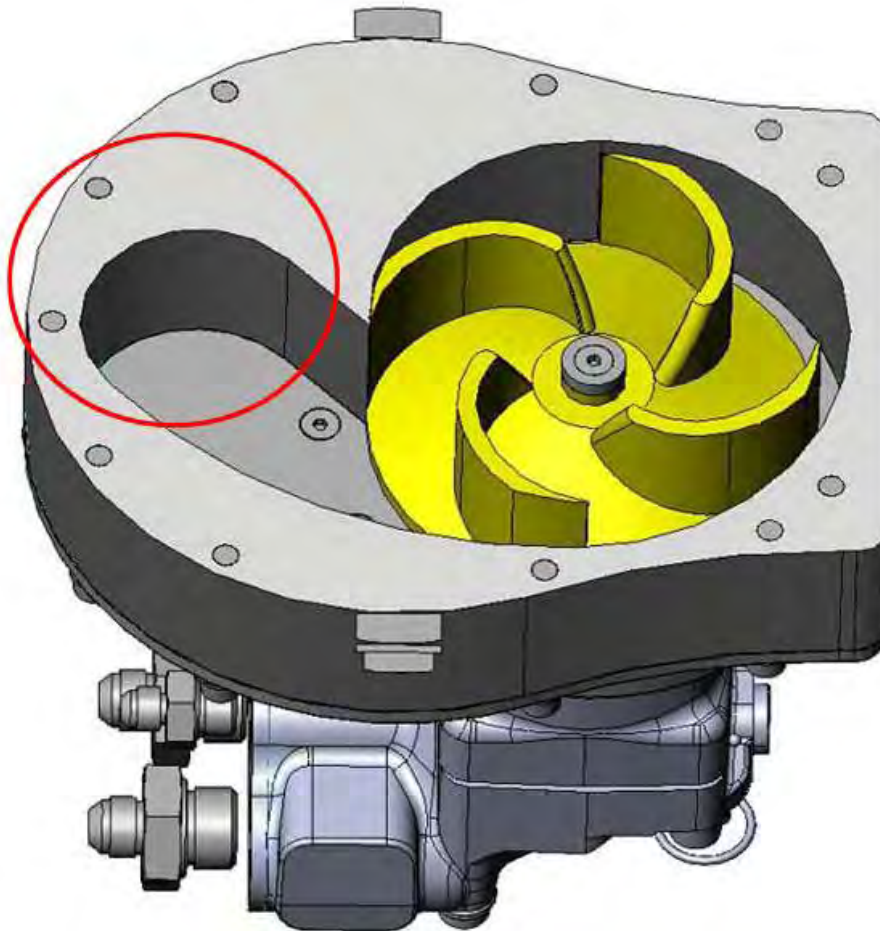

Figure 6.1: Illustration of the impeller casing, Casing 2. The red circle shows the "wall" where the water crash, instead of being guided through.

Casing 2 was modified with a more “pipe” looking end, so that the water could be better guided to the top casing. The modified part can be seen in Figure 6.2 below.

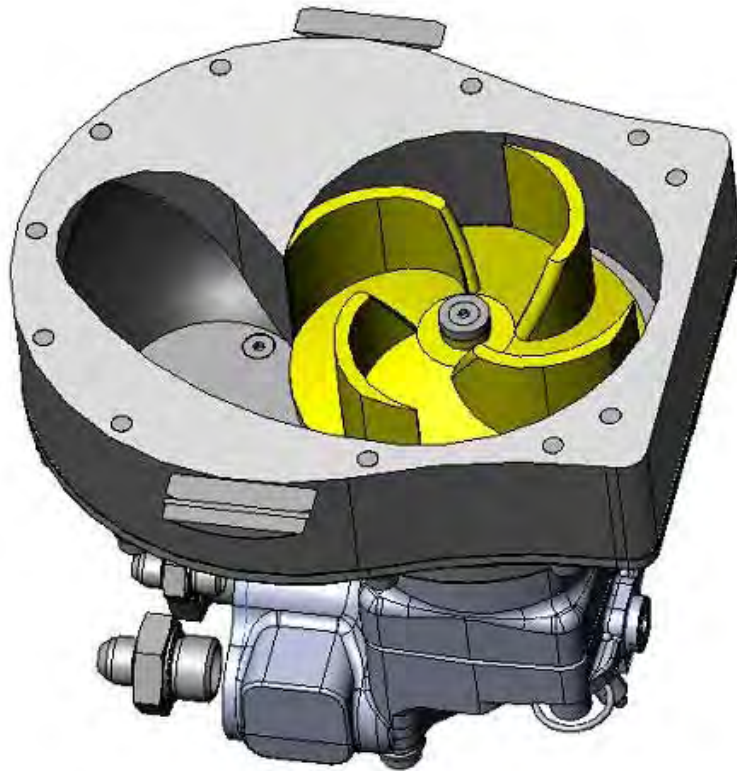

Figure 6.2: The improved casing, *Casing 3*, giving the water a more hydrodynamic flow path.

Impact of modification:

Changing to *Casing 3* gave the following result:

- 1460 lpm (at 175 bar) → **1500 lpm** (at 200 bar) (Test 4 → Test 5)

That is an increase of 40 lpm. By looking at the system, we have improved the flow path from the impeller casing to the top casing. But as the rest of the flow path is not improved, it might reduce the effect from casing 3. To prove this, it was necessary to test the Suction Kit without the top casing and flow regulator. As we also suspected that the top casing and flow

regulator is causing high pressure loss and flow resistance in the system, a test like this could prove these arguments. This test gave the following results:

- 1714 lpm (at 150 bar) → **1823 lpm** (at 200 bar) (Test 8 → Test 9)

In addition to prove that the top casing and flow regulator is causing a massive pressure loss, the modified casing in this test showed an increase in flow rate of more than 100 lpm. To make test 8 and 9 possible, the hose connector was mounted directly on the plate separating the top and impeller casing (see Figure 6.3). Because of this setup it was not possible to fully fasten two of the bolts keeping the Suction Kit together. This again caused a small leakage through the sealing material. During testing this was clearly visible as the water from this leakage could be seen as a small jet of water squirting a couple of meters up from the water tank. With this in mind the results from test 8 and 9 would probably have been even higher, maybe 30-40 lpm more, by stopping this leakage. However, the work to stop this leakage would be time consuming, and as these tests were set up only to prove pressure loss, it was not seen necessary.

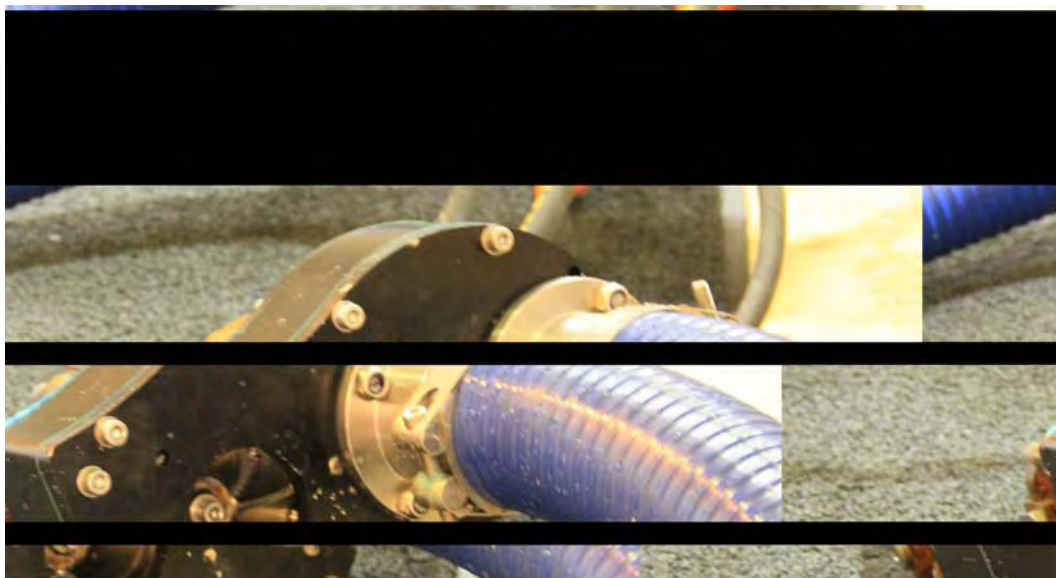

Figure 6.3: Shows the Suction Kit without the top casing and Flow regulator.

6.4.5. Grinding and polishing

As explained under “*Pressure loss and Flow resistance*”, sharp edges and turns create turbulence and increase resistance for the flow. In an attempt to decrease these factors, some parts in the Suction Kit were grinded and polished as much as possible in an effort to give a better flow path (see Figure 6.4- 6.7). The parts that were modified were the inlet, outlet and the plate separating the impeller and top casing. These 3 are the only parts in the Suction Kit that can be ground and polished and give an effect.

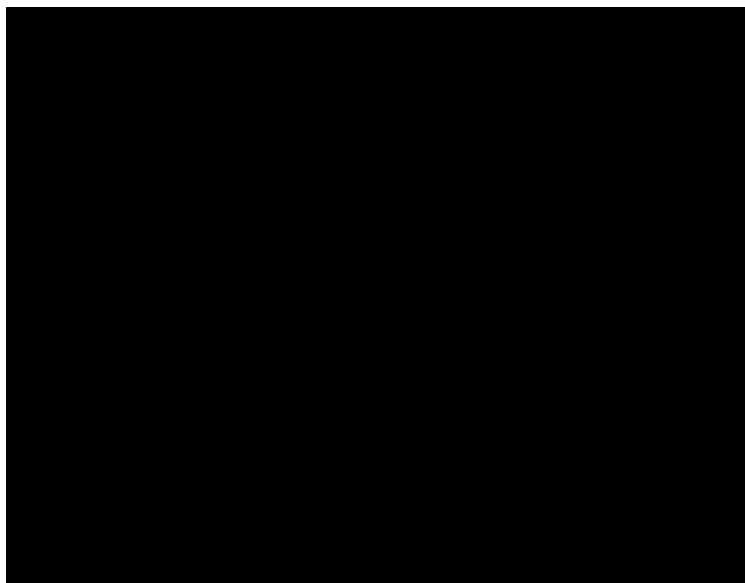

Figure 6.4: Shows the Top casing untreated.



Figure 6.5: Top casing grinded and polished.



Figure 6.6: Shows the bottom of the plate after treatment.



Figure 6.7: Showing the top of the plate after treatment.

With *Casing* and *Motor 2* we got the following result:

- 1460 lpm (at 175 bar) → 1550 lpm (at 170 bar) (Test 4 → Test 6)

With *Motor 2* and *Casing 3* we got:

- 1500 lpm (at 200 bar) → 1600 lpm (at 150 bar) (Test 5 → Test 7)

We got an increase in flow rate of about 100 lpm by grinding and polishing these 3 parts. This gives a picture of how big influence sharp bends, walls and turns might have on the flow rate.

6.5. Results of modifications

After the modifications presented above, the flow rate has been increased to a value of 1600 lpm (based on real modifications). The test without top casing and flow regulator was performed to prove high pressure losses and flow resistance and gave much higher flow rate, but the Suction Kit is not operative in this state. The different values from the tests can be seen in Figure 6.8.

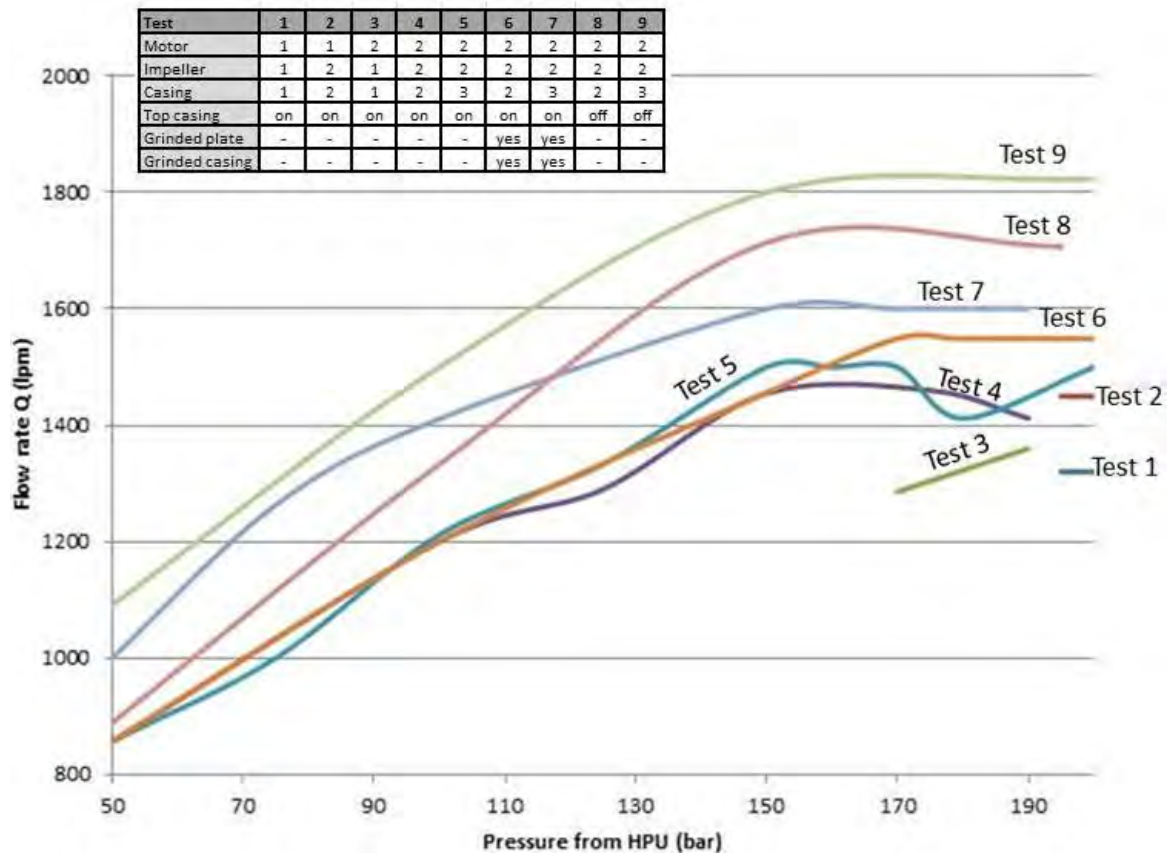

Figure 6.8: Graphs from the different tests.

From the graph you can see that after each modification the curve of the Suction Kit's performance is increasing. It is also the Tests 8 and 9 that has the highest increase in flow rate as the pressure loss and flow resistance is greatly reduced in these two tests.

The flow rate has been increased 280 lpm, 21,2%, without any big changes in the Suction Kit's dimensions. Some modifications gave bigger improvements than others. A table showing the different values from the tests can be seen below (Table 3), the increase in flow rate can also be seen from Table 4.

	Test 1	Test 2	Test 3	Test 4	Test 5	Test 6	Test 7	Test 8	Test 9
Motor	9,8 cm ³	9,8 cm ³	14,3 cm ³	14,3 cm ³	14,3 cm ³	14,3 cm ³	14,3 cm ³	14,3 cm ³	14,3 cm ³
Impeller	1	2	1	2	2	2	2	2	2
Casing	1	2	1	2	3	2	3	2	3
Top casing	on	on	on	on	on	on	on	off	off
Grinded plate	-	-	-	-	-	yes	yes	-	-
Grinded casing	-	-	-	-	-	yes	yes	-	-
Hyd.Press	Flowrate	Flowrate	Flowrate	Flowrate	Flowrate	Flowrate	Flowrate	Flowrate	Flowrate
25									
50				857 lpm	857 lpm	857 lpm	1000 lpm	889 lpm	1091 lpm
75					1000 lpm		1263 lpm		
100				1200 lpm	1212 lpm	1200 lpm	1411 lpm	1333 lpm	1500 lpm
125				1290 lpm	1333 lpm				
150				1455 lpm	1500 lpm	1456 lpm	1600 lpm	1714 lpm	1800 lpm
160					1500 lpm				
170			1286 lpm		1500 lpm	1549 lpm	1600 lpm		
175				1460 lpm					
180					1412 lpm	1549 lpm	N/A lpm		
190			1360 lpm	1412 lpm			1600 lpm		
195			N/A lpm	N/A lpm			N/A lpm	1707 lpm	
200	1320 lpm	1450 lpm	N/A lpm	N/A lpm	1500 lpm	1549 lpm	N/A lpm	N/A lpm	1823 lpm

Table 3: Results from the different tests with different modifications.

The different modifications and changes done for each test:

- Test 1 = Original impeller and motor
- Test 2 = New impeller, original motor
- Test 3 = New impeller, new motor
- Test 4 = Original impeller, new motor
- Test 5 = New impeller, casing and motor
- Test 6 = New impeller, motor old casing, grinded plate and casing
- Test 7 = New impeller, casing and motor, grinded plate and casing
- Test 8 = New impeller, org. casing, without top casing
- Test 9 = New impeller and casing, without top casing

Test 2 – Test 7 shows what can be called “real” improvement, as these tests are performed while the Suction Kit is fully operational. Test 8 and 9 shows a flow rate which implies that the function of reversing the flow is not possible.

With an increased flow rate of 280 lpm based on 4 modifications the tests show that increasing the height of the impeller and grinding and polishing a number of parts gave the best result. Motor 2 and Casing 3 also helped increase the flow rate as seen in Figure 6.9.

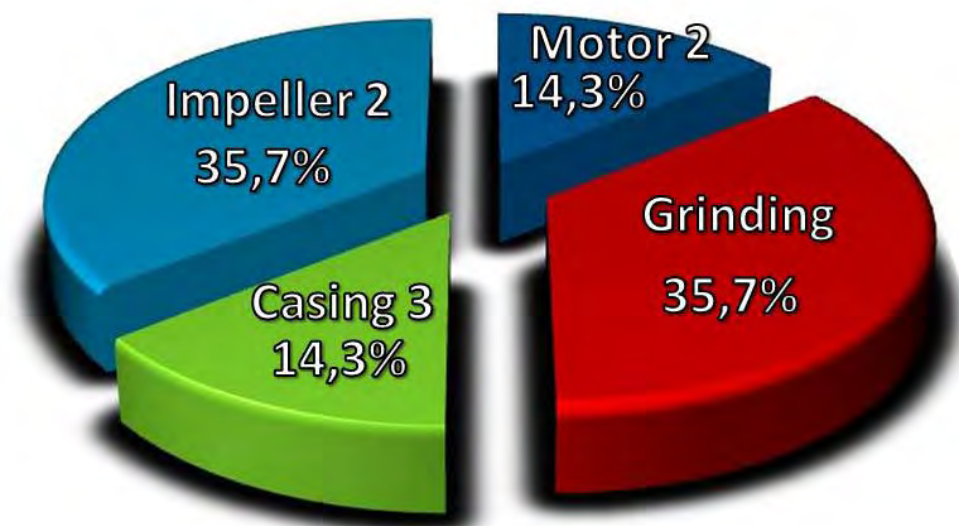

Figure 6.9: Total “real” increase.

By looking at the numbers of the total increase, including the removal of the top casing and flow regulator, we get another picture of how the different modifications increased flow rate (Figure 6.10). An approximately increased flow rate of 503 lpm based on 5 modifications gives the total increase. With *Casing 3*, without the top casing and flow regulator, the flow rate is increased 47,6%. In this example modifying the impeller is the next best modification with an increased flow rate of 24,4%

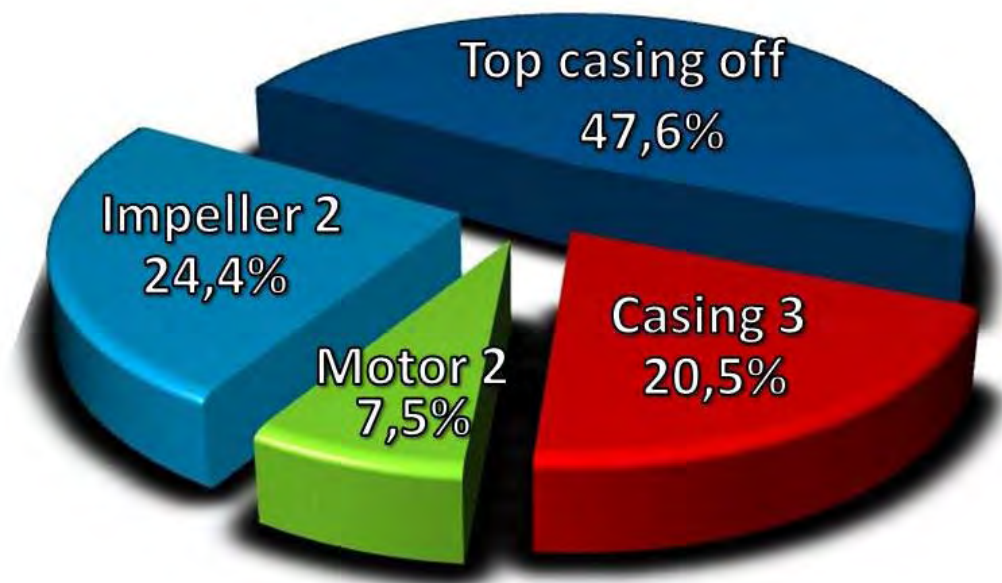

Figure 6.10: Total increase.

	Test 1	Test 2	Test 3	Test 4	Test 5	Test 6	Test 7	Test 8	Test 9
Motor	9,8 cm ³	9,8 cm ³	14,3 cm ³	14,3 cm ³	14,3 cm ³	14,3 cm ³	14,3 cm ³	14,3 cm ³	14,3 cm ³
Impeller	1	2	1	2	2	2	2	2	2
Casing	1	2	1	2	3	2	3	2	3
Top casing	on	on	on	on	on	on	on	off	off
Grinded plate	-	-	-	-	-	yes	yes	-	-
Grinded casing	-	-	-	-	-	yes	yes	-	-
Result:	Base Case	vs Test 1	vs Test 1	vs Test 3	vs Test 4	vs Test 4	vs Test 5	vs Test 1	vs Test 1
Result in lpm:	- lpm	130 lpm	40 lpm	100 lpm	40 lpm	89 lpm	100 lpm	394 lpm	503 lpm
Result in %:	- %	9,85 %	3,03 %	7,353 %	2,74 %	5,933 %	6,456 %	29,85 %	38,11 %
Total Upgrade lpm:	- lpm	130 lpm	40 lpm	140 lpm	180 lpm	229 lpm	280 lpm	394 lpm	503 lpm
Total Upgrade %:	- %	9,85 %	3,03 %	10,61 %	13,64 %	17,35 %	21,21 %	29,85 %	38,11 %

Table 4: Shows the increase in flow rate due to the different modifications.

7. Conclusion

The challenge in this thesis was to modify a Suction Kit delivered by Oceaneering A/S, to meet client specifications and requirements. The thesis had the target to improve the flow rate from 1300 lpm to 2000 lpm (an increase of 53%). In addition some other requirements should be looked at if the time frame would allow. However, the work to improve the flow rate in order to try to reach the specified 2000 lpm, appeared to be demanding. Hence, most of the time was spent to increase the flow rate as much as possible and to identify further possible improvements.

Five different modifications were carried out during the work with this Suction Kit;

- Increasing the power input
- Modification of the impeller (increased height)
- Modification of the casing (improved flow path)
- Grinding & polishing of selected flow parts area
- Removal of the top casing

Improving the design of the impeller casing with the intention to better guide the water flow to the top casing, along with changing the motor gave smaller increases. It became clear that the limitation of flow was not caused by insufficient power input. These two changes led to an increased flow rate of approximately 40 lpm each. Increasing the impeller height and grinding/polishing some parts gave a better increase in flow rate, both improving the value with 100 lpm.

The modification that gave the highest flow rate was the removal of the top casing. This gave a flow rate of 1823 lpm, which were an approximate increase of 323 lpm. In addition to improving the flow rate, this increase proves the high pressure loss and flow resistance inside the Suction Kit and top casing. It also showed an increase in flow rate of 109 lpm with Casing 3 in this state. However, as it is necessary to ensure the possibility of a reversed flow as per client specification, the Suction Kit is not fully operative without the top casing/flow regulator. It should nonetheless be looked into optimizing this part in order to achieving the required flow rate. The modifications done in the different tests can be seen in Table 5, the results can be seen in the box diagram in Figure 7.1.

Test	1	2	3	4	5	6	7	8	9
Motor	1	1	2	2	2	2	2	2	2
Impeller	1	2	1	2	2	2	2	2	2
Casing	1	2	1	2	3	2	3	2	3
Top casing	on	on	on	on	on	on	on	off	off
Grinded plate	-	-	-	-	-	yes	yes	-	-
Grinded casing	-	-	-	-	-	yes	yes	-	-

Table 5: Modifications performed in the different tests.

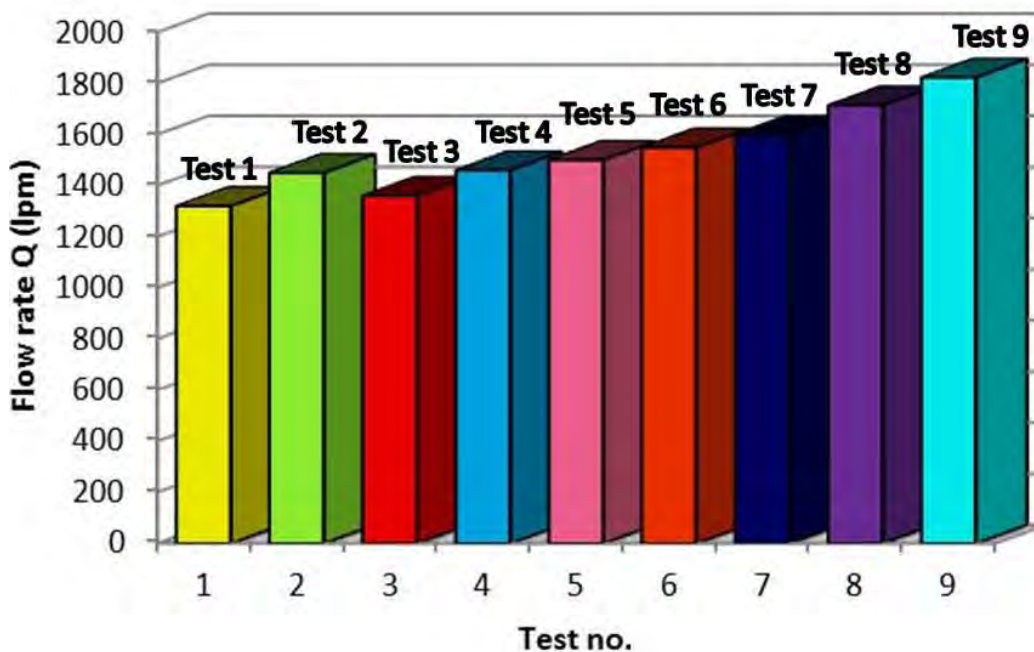

Figure 7.1: Box diagram showing max flow rate from the different tests.

8. Recommendations for further work

With the top casing mounted, the highest flow rate achieved was 1600 lpm (Test 7). For further optimization the Suction Kit should be designed more hydrodynamic to give a better flow path. It should also be looked into designing an optimal volute casing and flow regulator, as these elements are reducing the pumps efficiency. This, in addition to implementing a well designed diffuser, which is expected to increase the pump efficiency by 3-10%, should bring the performance of the Suction Kit near the required flow rate.

Clearly the largest problem with this Suction Kit is the high pressure loss. If this is reduced 50%, theoretical analysis done as part of this thesis, indicate a potential increase of the flow rate to well above 2000 lpm – possibly up to 2100 – 2200 lpm. If these changes do not increase the flow rate sufficiently, the Suction Kit's flow area must be increased. However, this will most likely increase the overall dimensions of the unit.

9. References

- [1] <http://business.highbeam.com/industry-reports/equipment/pumps-pumping-equipment>
- [2] API standard 610 “Centrifugal Pumps for Petroleum, Heavy Duty Chemical, and Gas Industry Services” (eighth edition, august 1995)
- [3] <http://en.wikipedia.org/wiki/pump>
- [4]
<http://www.pdhengineer.com/Course%20Files/Completed%20Course%20PDF%20Files/Pumps%20Centrifugal%20vs%20Positive%20Displacement%20Word%20Document.htm>
- [5] <http://www.britannica.com/EBchecked/media/7035/Volute-centrifugal-pump>
- [6] Bye, Georg (1967), Pumper, Vojens, P.J. Schimdt
- [7] Alvarez, Henrik (1990), Energiteknik Del 1, 3. Edition 2006, Lund, Studentlitteratur
- [8] http://mahavirengitech.com/chemical_process_pumps.html
- [9] <http://www.maintenanceworld.com/Articles/engresource/centrifugalpumps.pdf>
- [10] Stepanoff, A.J. (1948), Centrifugal and Axial Flow Pumps, 2. Edition 1957, USA, John Wiley & Sons, inc.
- [11] Bachus, Larry & Custodio, Angel (2003), Know and Understand Centrifugal Pumps, UK, Elsevier Advanced Technology
- [12] <http://www.cheresources.com/content/articles/fluid-flow/centrifugal-pumps-basic-concepts-of-operation-maintenance-and-troubleshooting?pg=1>
- [13] http://www.gouldspumps.com/cpf_0010.html
- [14] Support from Oceaneering’s ROV department, conversation with David Knutsen.
- [15] http://en.wikipedia.org/wiki/Volumetric_flow_rate
- [16] Idelchik, I.E. (2003), Handbook of Hydraulic Resistance, 3. Edition 2008, Delhi, Pashupati Printers Ltd.
- [16-1] Chapter 4, page 210
- [16-2] Chapter 6, page 407
- [16-3] Chapter 4, page 220

Appendix

- A. Specification by Oceaneering A/S
- B. Client specification
- C. Test log
- D. Additional photots

Specification defined by Oceaneering



Memo

Oceaneering AS
P.O. Box 8024
4068 Stavanger, Norway
Phone: 51 82 51 00 – Telefax: 51 82 52 90

Subject:	Modification of Suction Kit	Date:	11.01.11
Project No.:	NA	Time:	10.00 – 11.00
Ref. No.:	001	Location:	Hinna base
Copied to:	Gunnar Ulland, Charles B. Hansen, Simon Bruset (s.bruset@live.co.uk)	Issued by:	Gjermund Rath

Design kriterier

- Pumpe kapasitet I fra 1300 l/min til 2000 l/min
- "Real time" flow måling i neddykket tilstand, flow måling ønskes utført uten å tilføre flere bevegelige deler, eksempel på deler som ikke ønskes er turbin/ impeller da dette vil være en mekanisk hindring for eventuelle partikler som skal passere gjennom pumpen
- Det er ønskelig å ha "real time" måling av delta p i neddykket tilstand
- All "real time måling" kjøres via et 4-20mAmp. signal, dette signalet overføres til ROV kontrollsystem via kabel i fra Suction Kit, signalet leses på laptop i kontroll container, grafisk interface for denne applikasjonen er ikke en del av oppgaven
- Pumpen skal ha en kapasitet til å oppnå minimum 2,5 bar overtrykk, samt tilsvarende undertrykk i neddykket tilstand, dvs. ved dybde 25 meter eller mer
- Sug/ trykk kapasitet skal kunne økes lineært
- Der skal være en lett leselig indikator som viser når sug/ trykk er aktivisert, dvs. en indikasjon på pumpen er i drift og om den suger eller trykker
- Fysiske mål bør ikke overstige dagens i vesentlig grad
- Maksimum vekt i vann settes til 30 kg.
- Øvrige funksjoner på Suction kit beholdes tilnærmet likt som i dag, tenker da på mekanisk interface og hydraulisk tilkobling

Specification defined by Statoil

✓ X Flow slaving.
 ✓ X DELTA TANK FALL ΔP
 ✓ X BESSEMER som i DR CA.
 ✓ X VETA MAX SOLG I VAND

Governing document: Subsea Intervention Systems

Case Jicson Internal

Important considerations for the guidewire lift anchor are the bend which can occur in the wire when the guide post is picked up from the deck and the safety of the system during launch and recovery. A Guidewire lifting anchor must be clearly identified as such to avoid unintentional installation of a Guidewire lifting anchor as a standard guidewire anchor.

2.4.10 ROV mounted suction pump

- 1) This section relates to pumps typically used for suction piles and levelling of subsea structures with suction skirts.
- 2) One HPU skid with two independent pumps circuits with the following specifications: Circuit 1: High pressure, low flow rate, Circuit 2: Low pressure, high flow rate
- ✓ 3) The pump should be able to provide at least 250 kPa (36psi) relative overpressure or underpressure (suction) in the skirt compartments/ suction pile.
- ✓ 4) The suction shall be possible to increase linearly. 2. 2.5 bar
- ✓ 5) There shall be an easy readable indicator showing when pressure or suction is applied. The indicator shall be clearly visible by use of the ROV cameras.
- ✓ 6) The pump shall enable reasonable levelling velocities; i.e. the pump capacity should be at least 2000 l/min (530gpm)
- 7) As part of the pump qualification, and during mobilisation prior to offshore operations, the pump shall be function tested to document that the WROV is capable of supplying the required hydraulic pressure and flow to the pump. The test shall be performed simultaneously with manipulator operation and normal ROV thrust. The performance shall be documented through a flowmeter or manometer.
- 8) An optional pump with 500 kPa (72psi) suction capacity shall be supplied upon request if detailed engineering reveal need for increased pump capacity.

2.4.11 Buoyancy

- 1) Buoyancy elements (fixed buoyancy) for subsea operations should be constructed from syntactic foam or syntactic foam with microspheres. The depth rating of the buoyancy shall be marked on the buoyancy and not be exceeded in the operation.
- 2) Buoyancy shall not be uncontrollably released from depth. Prior to removal of the buoyancy from the main object the buoyancy element shall be secured to a clump weight. When the buoyancy element is released from the main element the uplift shall be transferred to the clump weight. Thereafter the clump weight and the buoyancy shall be recovered to surface in a controlled manner by ROV or by a crane/winch.
- 3) Neither aluminium nor plastic air/gas filled buoys shall be used as buoyancy in subsea operations. This for risk

Concept development and engineering (CD&E) Technical and professional requirements, TR1231, Final Ver. 3, valid from 2010-10-27

Page 20 of 34

Validity area: Corporate techn. and prof. req./All locations/All value chains/Offshore

Test log

Test 1

4.March 2011:

The new impeller is mounted. The Suction Kit is working, but the test results are not very good. We also had a small leakage of hydraulic oil, just a misunderstanding by the mechanic that didn't think he needed a "drain".

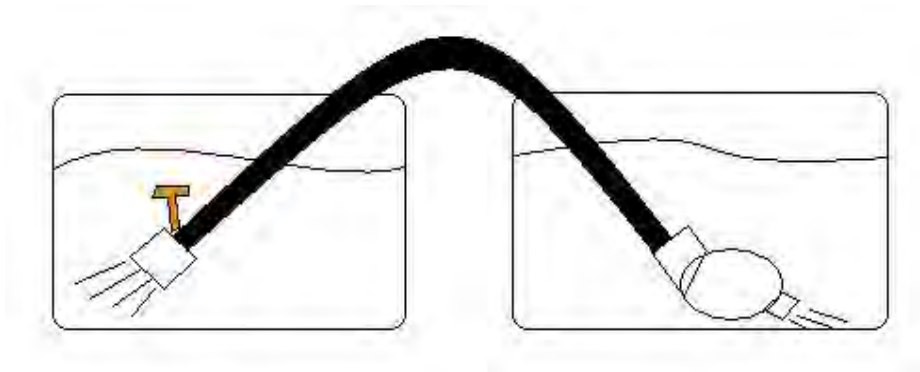

The results (ca. 200 bar):

Suction:

- 400 liter in 28 seconds = 857 lpm
- 300 liter in 21 seconds = 857 lpm

Pumping:

- 500 liter in 26 seconds = 1154 lpm

Improvements for next time:

For now the only thing we can measure is the flow rate; clocking how much time it take to move 400 liters. We should also measure the pressure at the inlet and outlet, but so far they don't have the necessary equipment in the workshop.

The inlet is 3", the outlet and hose is 2". The hoses from the HPU are ¼", changing them to ½" will give more flow from the HPU (changing from JCP 6 to JCP 12?). We also need to

change the outlet and hose from 2" to 3". We will also mount a flow meter to measure the flow from the HPU.

We also consider changing to another HPU because the one we used doesn't deliver enough lpm.

We will also change the execution of the test. During Test 1 we took the time from the moment we put max pressure on the pump. Next time we will wait until the pump has pumped 100 liters before we start taking the time. This is to eliminate any variations and disturbances in flow and start when the flow is more stabilized.

16. March 2011:

3" inlet and outlet. We have mounted a flow meter from the HPU to measure lpm. We know that the HPU has a capacity of at least 60 lpm, but we only have 30 lpm at max pressure (200 bar). At first we thought there was something wrong with the flow meter, after changing it we still had the same flow. To check if it was the Suction Kit that was the problem, we took a test in air. The flow meter then showed 50 lpm. This means that the problem is too much resistance inside the Suction Kit; the pump can't get rid of the water. We also discovered that the flow regulator was installed incorrectly, however, this doesn't affect the flow rate.

In an attempt to increase the lpm from the HPU and the flow rate, we increased the holes in the plate that separates the top casing and the impeller casing from 75mm to 80mm. This did not give any noticeable effect.

We also tested the Suction Kit with the original impeller, which gave us 35 lpm from the HPU.

Results:

500 liter in 21sec = 1428,6 liter/min

(30 liter/min from HPU, 200 bar)

Test with increased holes; 80mm (new impeller):

500 liter in 20,78 sec = 1449,3 liter/min

Test with small impeller:

500 liter in 22,6 sec = 1327,4 liter/min

500 liter in 22,9 sek = 1310 liter/min

Conclusions:

We will test the Suction Kit without the top casing to see if we get more flow from the HPU. Took some time to get this test through because the mechanic thought it would be too much of a mess (water).

18. March 2011:

We tested the Suction Kit without the top casing but it didn't give much better flow from the HPU (it didn't leave a mess either). It seems to be too much resistance for the hydraulic motor, a combination of a heavy impeller and that it is too hard to move the water through the pump. With no load the motor can achieve an operating speed of 10200 RPM, now it is operating with 3061 RPM. After discussing the problem with Kenneth Fosså and Gjermund Rath we decided to order in a larger motor. Instead of the original $9,8 \text{ cm}^3/\text{rev}$ motor, we ordered in a $14,3 \text{ cm}^3/\text{rev}$ motor from Kurt Wiig at Vitec. The motor was supposed to be delivered after 5 weeks.

8. April 2011:

As the motor has not arrived yet, I'm just writing on the thesis and planning which parts that should be modified depending on the outcome of the new motor.

11. April 2011:

I edited the drawing of the impeller to match the new motor.

26. April 2011:

I called Vitec and Kurt Wiig to check if the motor had been delivered. It had been sent from the factory in Sweden Thursday 21. April.

27. April 2011:

The new motor arrived Oceaneering's warehouse. We wrote a requisition for the new impeller after checking that it would fit the new motor. Estimated delivery of the new impeller is set to 13.05.

28. April 2011:

To start testing with the new motor before May, the workshop will make the impeller fit the new motor. We might be able to start the new test early next week.

3. May 2011:

The workshop did not have resources to modify the original impellers. I delivered the impellers to Promet Friday 29. April. Kenneth Malmin called me yesterday, 2. May, and said they could deliver the new impeller Wednesday or Thursday this week, instead of modifying the old impellers. Really happy with that! We might test the Suction Kit Thursday or Friday this week!

Been writing more about what influencing the flow rate. Also tried to call a couple of professors at NTNU, but none of them answered.

5. May 2011:

Picked up the modified original impeller at Promet. The new impeller will be done hopefully during Monday. Hope to start testing again Monday.

9. May 2011:

Tested the Suction Kit with the modified original impeller:

1. 450 liter – 21 sec = 1286 liter/min (ca.170 bar, 50 liters from HPU, not max)
2. 400 liter – 17 sec = 1411 liter/min (ca.190 bar, 55 liters from HPU)
3. 400 liter – 17,72 sec = 1354 liter/min (ca.190 bar, 55 liters from HPU)
4. 400 liter – 18 sec = 1333 liter/min (ca.190 bar, 55 liters from HPU)

The results from the testing today was disappointing. We found that we had a new average flow rate in water of 1370 liter/min.

Also went to Promet and picked up the new impeller. Will test again tomorrow. From calculations we have increased the RPM's with about 800:

$$\frac{dm^3}{rev} \cdot \frac{rev}{min} = \text{liter}/min$$

$$\frac{\frac{liter}{min}}{\frac{dm^3}{rev}} = rev/min$$

$$\frac{55 \frac{liter}{min}}{14,3 \cdot 10^{-3} \frac{dm^3}{rev}} = 3846 \frac{rev}{min}$$

In the first tests we had:

$$\frac{30 \frac{liter}{min}}{9,8 \cdot 10^{-3} \frac{dm^3}{rev}} = 3061 \frac{rev}{min}$$

We have an increase in RPM of $3846 - 3061 = 785$ RPM.

10. May 2011:

Tested the Suction Kit with the new modified impeller:

1. 400 liter (190 bar, 50 liter) – 17 sek = 1412 liter/min
2. 400 liter (150 bar, 50? liter) – 16 sek = 1500 liter/min
3. 400 liter (50 bar, 23 liter) – 28 sek = 857 liter/min
4. 400 liter (100 bar, 35 liter) – 20 sek = 1200 liter/min
5. 400 liter (125 bar, 40 liter) – 18,6 sek = 1290 liter/min
6. 400 liter (150 bar, 50 liter) – 16,5 sek = 1454 liter/min
7. 400 liter (100 bar, 35 liter) – 20 sek = 1200 liter/min
8. 400 liter (150 bar, ? liter) – 17 sek = 1412 liter/min
9. 400 liter (175 bar, 46 liter) – 16 sek = 1500 liter/min
10. 400 liter (175 bar, 50 liter) – 17 sek = 1412 liter/min
11. 400 liter (190 bar, 50 liter) – 17 sek = 1412 liter/min

Table:

pressure	Flow rate
50	857
100	1200
125	1290
150	1450
175	1460
190	1412

Graph:

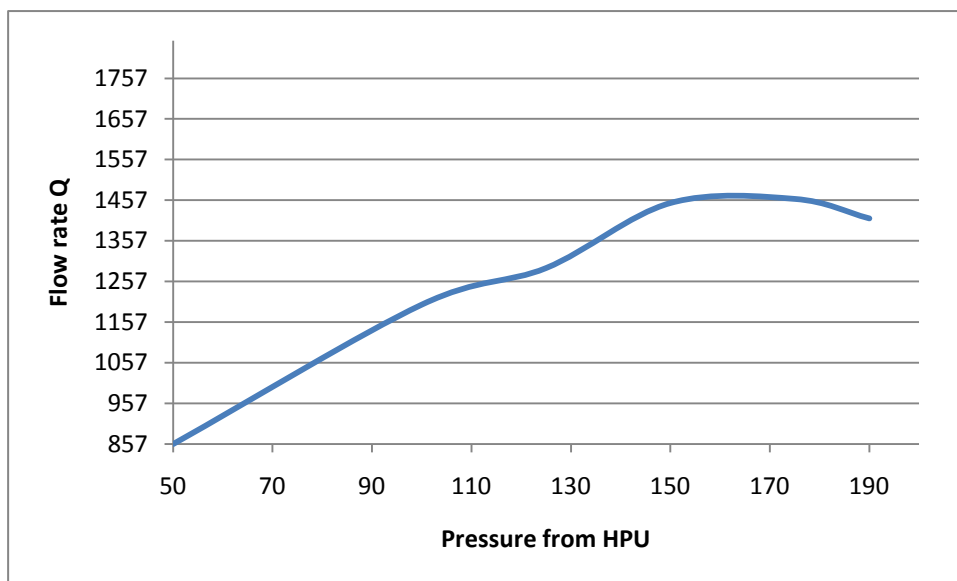

Comments: We can see that we have max flow rate when the pressure from the HPU is around 160-170 bar. When the HPU delivers 160 bar we have 50 lpm of hydraulic oil:

$$\frac{50 \frac{\text{liter}}{\text{min}}}{14,3 \cdot 10^{-3} \frac{\text{dm}^3}{\text{rev}}} = 3496 \frac{\text{rev}}{\text{min}}$$

At max flow rate we have approximately 3500 RPMs.

Clearly we didn't achieve much by changing the motor. Will start to improve the hydrodynamic design of the pump. Have sent requests for two different parts to Promet (hoseconnector, impeller casing).

11. May 2011:

Ordered a new hose connector so we can start measuring inlet- and outlet- pressure and pressure loss. Will order a new impeller casing tomorrow with a more hydrodynamic design.

19. May 2011:

Spent the whole day to get an accurate measuring of the pressure. Seems that something is not working right. We get a lot of vibration and a value between 0,5-1 bar on the outlet.

20. May 2011:

Tried to measure the pressure difference with digital manometer and pressure transmitter. It is not easy to find the exact pressure at the inlet or outlet of the pump. This is probably because the flow is very turbulent and that the pressure value is not very high.

Planning to use another method to prove pressure loss and resistance by connecting the hose "directly" to the plate above the impeller casing and measure flow. The difference in flow rate we find, will be flow lost due to the top casing and flow regulator.

25. May 2011:

First test with hose connected directly to the impeller casing. Got good results and it looks like my assumption proved to be correct.

Test results (original casing, no flow regulator or top casing):

1. 400 liter (50 bar, 20 lpm) 27 sec = 889 liter/min
2. 400 liter (100 bar, 30 lpm) 18 sec = 1333 liter/min
3. 400 liter (150 bar, 40 lpm) 14 sec = 1714 liter/min
4. 400 liter (195 bar, 40 lpm) 13-14 sec = 1778 liter/min (assuming 13,5 sec)
5. 300 liter (195 bar, 40 lpm) 11 sec = 1636 liter/min (less accurate measuring..?)

We can clearly see that the top casing and flow regulator is causing flow resistance and pressure loss. Flow rate has increased almost 200 liter/min. We also have a small leakage in a small area close to the outlet. This is because the bolts holding the Suction Kit together had to be dropped in order to connect the hose connector to the impeller casing (see Figure T.1)

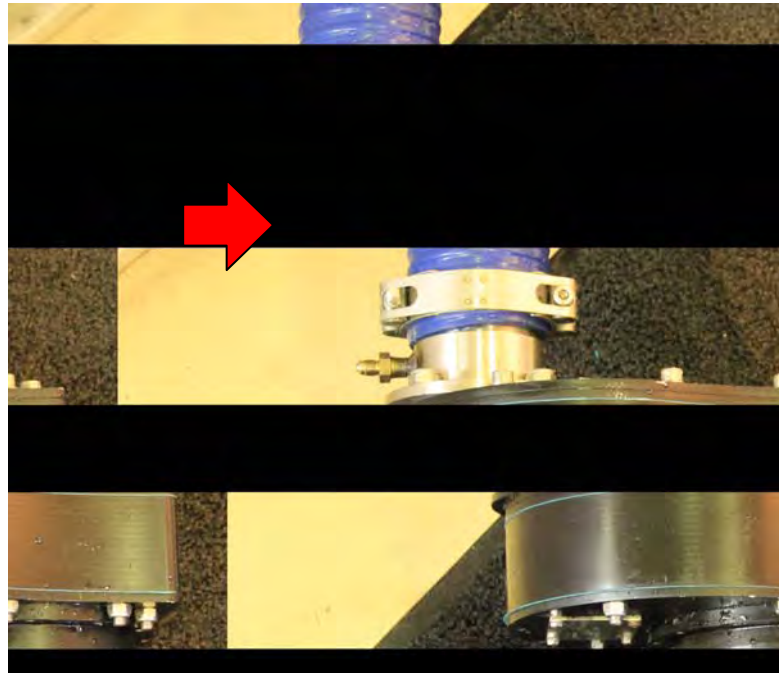
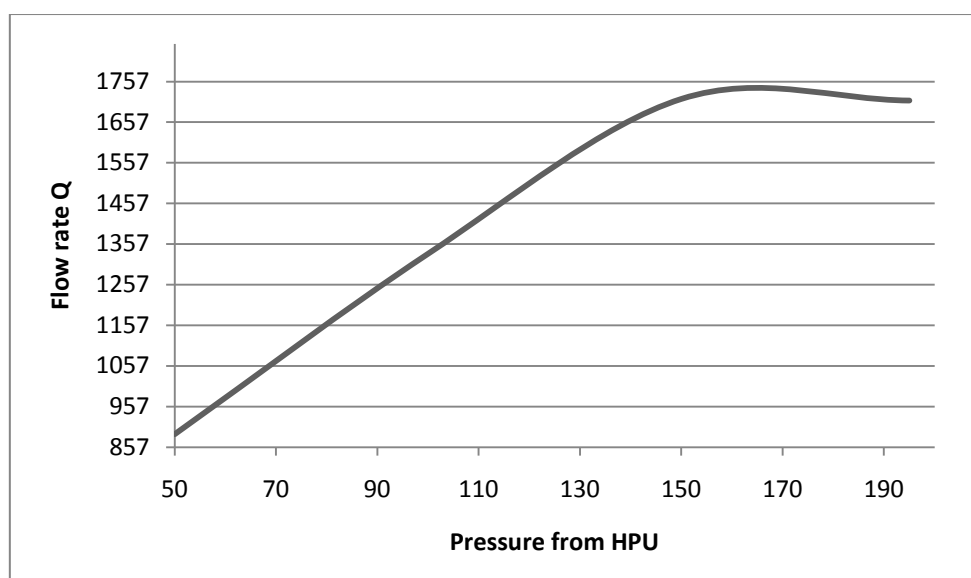

Figure T.1: Picture of Suction Kit without top casing and Flow regulator. The red arrow shows where the area of the leakage.

This means that the actual flow rate would be somewhat higher. Graph of the results:

Note: Because of the difference we got at 195 bar (see the 4. And 5 try) I used the average value of the two tries in the graph.



Comments: Compared to the graph from test we did 10. May, the graph is more linear to about 130-140 bar. We also have a higher max value of flow rate. We have proved how much pressure loss and flow resistance the top casing is causing.

Tomorrow we will perform a similar test as we did today, but with the new more hydraulic designed casing. I'm hoping for great improvements due to that part! We might get 1800-1900 liters/min..?:(

26. May 2011:

The Suction Kit was ready for testing with the new impeller casing when I arrived at Oceaneering. We got the following results (new impeller casing, no flow regulator or top casing):

1. 400 liter (50 bar, 20 lpm) 22 sec = 1091 liter/min
2. 300 liter (100 bar, 32 lpm) 13 sec = 1385 liter/min
3. 400 liter (100 bar, 32 lpm) 16 sec = 1500 liter/min
4. 350 liter (150 bar, 39 lpm) 12 sec = 1750 liter/min

There could have been several users of the hydraulic system when we took those last three tests..

5. 400 liter (100 bar, 31 lpm) 16 sec = 1500 liter/min
6. 400 liter (150 bar, 40 lpm) 13 sec = 1846 liter/min
7. 400 liter (200 bar, 35 lpm) 13 sec = 1846 liter/min
8. 300 liter (200 bar, 37 lpm) 10 sec = 1800 liter/min (less accurate measuring..?)

Graph from test:

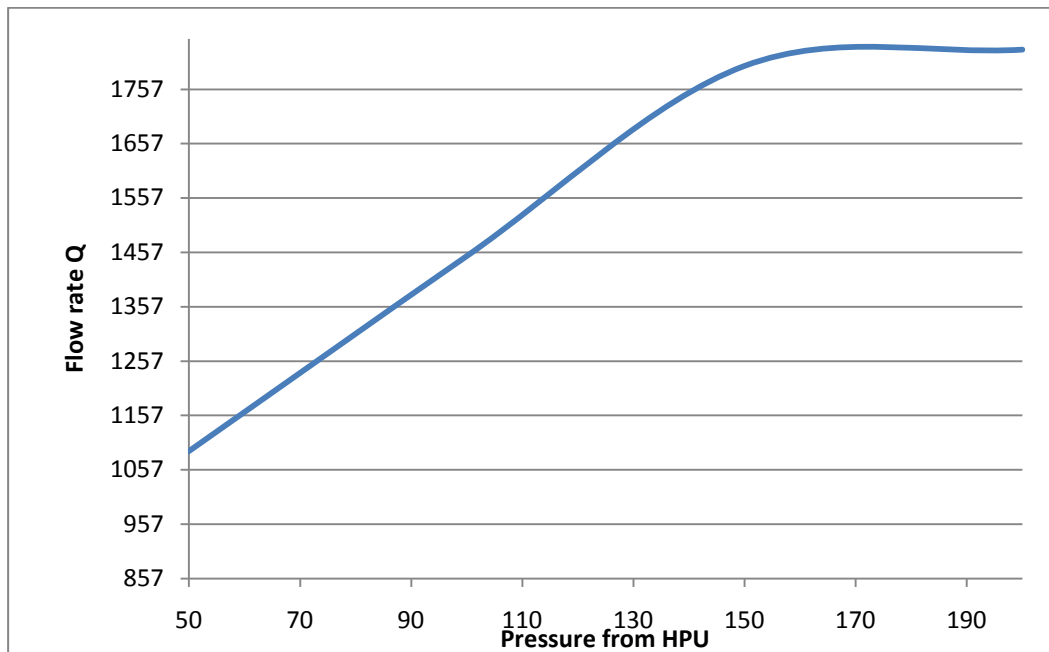

Comments: We got great results from this test. We had a flow rate as high as 1850 liter/min! This absolutely proves that the top casing is causing a lot of pressure loss and flow resistance to the system. We also got almost 150 liter/min more at max flow rate than with the original casing. This shows how much improvement this small adjustment means!

We have also identified some sources of error that might be present while testing, they are as follows:

- Temperature difference of hydraulic oil
- Other users of the hydraulic system
- Differences in start and stop when taking the time
- Amount of air and turbulence present in the flow at start up (that is present when almost 100 liters has been pumped).
- Missing bolts causing small leakage (for tests without flow regulator and top casing)

27. May 2011:

We found out yesterday that the impeller has not been proper fastened in the Suction Kit during the latest tests. Instead of pointing fingers we did some of the tests again. The difference was neglectable.

We tested the Suction Kit with the flow regulator, top casing and the new impeller casing. Test results are as follows:

Jetting/blowing:

1. 400 liter (50 bar, 23 lpm) 28 sec = 857 liter/min
2. 400 liter (75 bar, 26 lpm) 24 sec = 1000 liter/min
3. 400 liter (100 bar, 34 lpm) 19,6 sec = 1225 liter/min
4. 400 liter (100 bar, 32 lpm) 20 sec = 1200 liter/min
5. 400 liter (125 bar, 37 lpm) 18 sec = 1333 liter/min
6. 400 liter (150 bar, 43 lpm) 16 sec = 1500 liter/min
7. 400 liter (150 bar, 43 lpm) 16 sec = 1500 liter/min
8. 400 liter (160 bar, 45 lpm) 17 sec = 1412 liter/min
9. 400 liter (160 bar, 45 lpm) 16 sec = 1500 liter/min
10. 400 liter (170 bar, 45 lpm) 16 sec = 1500 liter/min
11. 400 liter (170 bar, 45 lpm) 16 sec = 1500 liter/min
12. 400 liter (180 bar, 50 lpm) 17 sec = 1412 liter/min
13. 400 liter (180 bar, 50 lpm) 17 sec = 1412 liter/min
14. 400 liter (200 bar, 55 lpm) 16 sec = 1500 liter/min

I've started to wonder if the difference in suction and blowing is greater than expected, so we tested the Suction Kit:

Suction:

1. 400 liter (50 bar, 25 lpm) 25 sec = 960 liter/min
2. 400 liter (100 bar, 34 lpm) 18 sec = 1333 liter/min
3. 400 liter (150 bar, 45 lpm) 16 sec = 1500 liter/min
4. 400 liter (200 bar, - lpm) 17 sec = 1412 liter/min

There is not a big difference in flow rate. We can see a large difference around 50 bar, but as the pressure increase the flow rate stabilize, so we will continue to primarily test the jetting/blowing mode (as there is no big difference).

For a lot of the adjustments it seems like we achieve a better flow rate at lower pressures, but we don't increase the max flow rate value itself. It might look like the only solution to make the improvement of a max flow rate to 2000 lpm is to make the Suction Kit bigger.

Graph for the first test, jetting/ blowing:

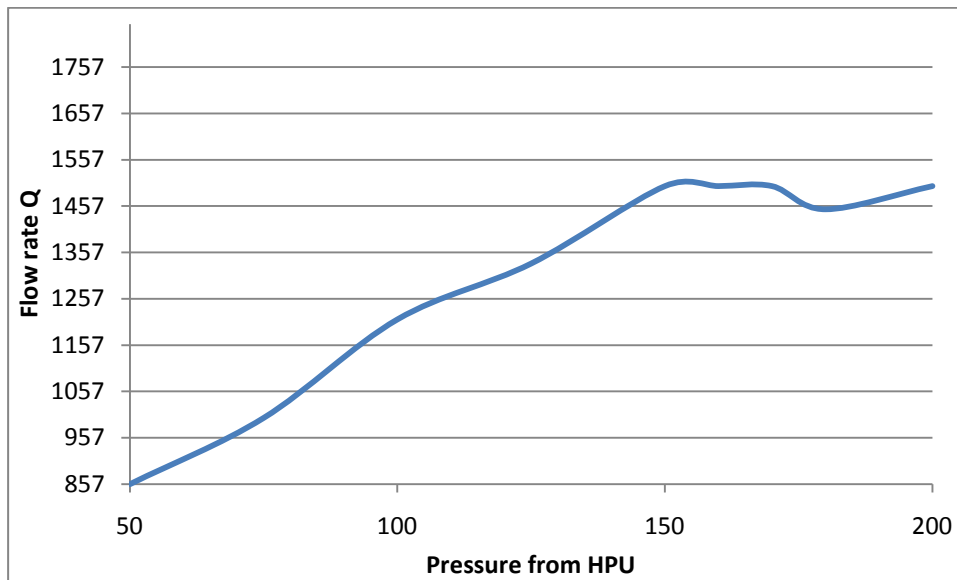

Comments: We have an increase in flow rate of 40-50 liters/min. The biggest difference is that we achieve max flow rate already at 150 bar (pressure from HPU). The test results also gave quite an uneven curve, if this is caused by high turbulence in the pump or inaccurate measuring is not easy to tell.

30. May 2011:

Tested the Suction Kit on pressures of 150-190, to see if the Suction Kit was performing better somewhere between 150 and 200 bar. The results have been included in the table and curve above. Also planned the work on filing down the edges of the inlet and outlet and the plate between the flow regulator and impeller.

31. May 2011:

The work on filing the parts on the Suction Kit started and it looks very good. Hope this will increase the flow rate a bit. I'm hoping for about 50 liters per minute more, but that might be a bit much to hope for. We might be able to start the final test on Friday.

03. June 2011:

Tested the Suction Kit with filed plate and filed top casing. The old casing (not the original one, but the one without hydrodynamic design) was mounted on. Monday we will test the same kit with the new casing.

Results:

1. 400 liter (50 bar, 22 lpm) 28 sec = 857 liter/min
2. 400 liter (100 bar, 35 lpm) 20 sec = 1200 liter/min
3. 400 liter (150 bar, 45 lpm) 16 sec = 1500 liter/min
4. 400 liter (150 bar, 45 lpm) 17 sec = 1412 liter/min
5. 400 liter (170 bar, 45 lpm) 15,5 sec = 1549 liter/min
6. 400 liter (180 bar, 48 lpm) 15,5 sec = 1549 liter/min
7. 400 liter (200 bar, 50 lpm) 15,5 sec = 1549 liter/min

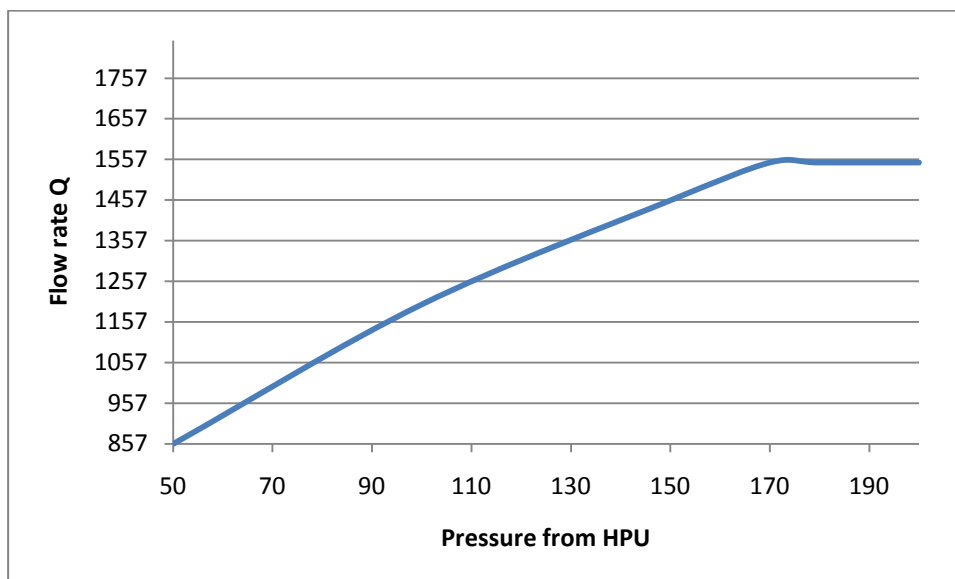

We have almost 50 litres more on max flow rate than we had with the new casing (but without the filed parts). So it might be possible to get around 1600 liters when we test the Suction Kit with the new casing and the filed parts.

06. June 2011:

Today we did a test with the filed plate and casing and the new casing. We experienced high vibrations on the hydraulic system around 180 bar, but when we increased the pressure to 190 bar it stabilized.

Results:

1. 400 liter (50 bar, 23 lpm) 24 sec = 1000 liter/min
2. 400 liter (75 bar, 27 lpm) 19 sec = 1263 liter/min
3. 400 liter (100 bar, 35 lpm) 17 sec = 1411 liter/min
4. 400 liter (150 bar, 41 lpm) 15 sec = 1600 liter/min
5. 400 liter (170 bar, 45 lpm) 15 sec = 1600 liter/min
6. 400 liter (180 bar, N/A lpm) 15 sec, invalid due to vibration

7. 400 liter (190 bar, 50 lpm) 15 sec = 1600 liter/min

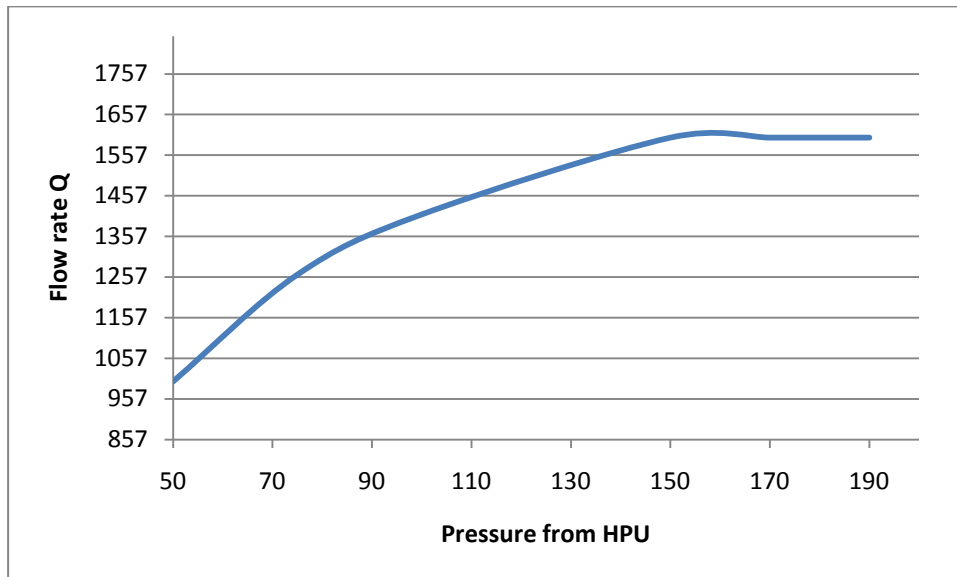

Again we achieve max value of flow rate at a lower pressure. In addition we also got about 50 lpm more by changing the casing.

Additional photos

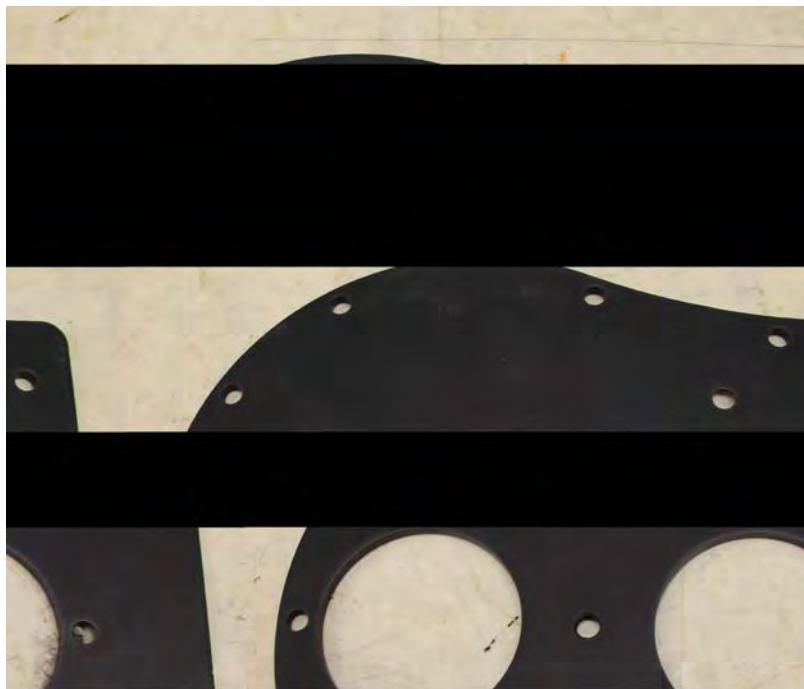

Figure T.2: The plate before treatment.

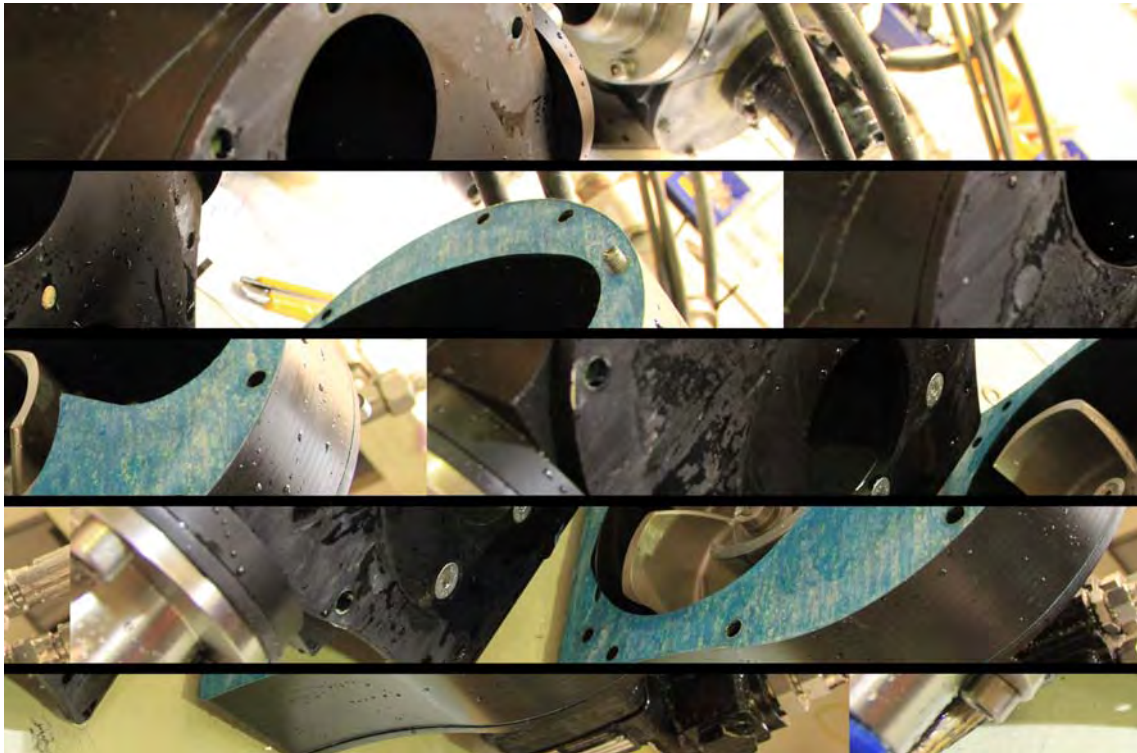

Figure T.3: Showing the impeller, impeller casing, and plate separating the impeller casing and top casing.



Figure T.4: Showing an disassembled Suction Kit.