



University of  
Stavanger

Faculty of Science and Technology

## MASTER'S THESIS

*Study program/ Specialization:*

*Offshore technology/  
Marine and subsea*

*Spring semester, 2013*

*Restricted access*

*Writer:*

*Jon Dale Gjerstad*

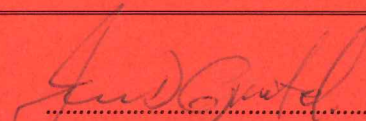

*(signatur forfatter)*

*Faculty supervisor:*

*Eiliv Janssen*

*External supervisor:*

*Frode Flugheim Heggstad*

*Title of thesis:*

*Design and development of portable nitrogen generator for Oil & Gas installations*

*Credits (ECTS): 30*

*Key words:*

- *Design*
- *Development*
- *Nitrogen membrane*
- *FEA*

*Pages: 81*

*+ enclosure: 41*

*Stavanger, June 21, 2013*

*Date/year*

## **i. Abstract**

In the oil and gas industry more applications are using nitrogen, nitrogen have normally been produce onshore and transported to an offshore installation, in bottle racks or liquefied in vessels.

Since the demand after nitrogen has increased during the last decade, some installation is producing local nitrogen onboard. But this is stationary big units that have problems to serve the rest of the demands on the installation.

Normal nitrogen generator that are in use now, are having separated systems, air compressor, nitrogen generator and sometimes high pressure compressors.

This thesis is taking the nitrogen onboard production to the next level, designing a small compact unit for operations in hazardous areas including Atex Zone 1.

Overall objective has been to develop an easy to use "plug & play" unit, utilizing only electrical power supply to produce nitrogen from the surrounding atmosphere and to deliver nitrogen at high pressure. This means that an air primary air compressor, nitrogen membrane and high pressure compressor have been integrated to one compact portable unit.

In order to develop a nitrogen generator that are producing nitrogen and are portable, compact components and efficiency solutions has to be integrated together.

In this master thesis a concept has been developed for a solution for nitrogen generation up to 300 bar discharge pressure. That is compact, designed with lifting arrangement and can be manual handled around on the installation.

Prototype will be constructed and manufactured in September/October 2013.

## ii. Acknowledgements

This master thesis is the final work in the 2 year Master degree program in offshore technology, marine and subsea at the University of Stavanger. The work was conducted in spring 2013 in collaboration with Nitrogas AS and E Innovation.

I will especially like to thank my supervisors Eiliv Janssen and Frode Flugheim Heggstad who have contributed with guidance, inspiration and input during the work. I would also like to thank Nitrogas As with Asbjørn Lunde and E Innovation with Evald Holstad and Øyvind Johannessen, for giving me the opportunity to do this master thesis and for inspiration and supervising during this thesis.

I would especially like to thank my family and my parents-in-law for motivation and practical help during my master degree.

To my wife Kristine, I will especially thank you for your love, understanding, motivation and support during my education.

## iii. Notations and abbreviations

CMS	Carbon Molecular Sieve
PSA	Pressure Swing Adsorption
CO <sub>2</sub>	Carbon oxide
Ar	Argon
HP	High Pressure
LP	Low Pressure
CCF	Compressor Correction Factor
ANR	Air Nitrogen Ratio

## List of tables

Table 2.1- Table of pros and cons for Membrane and PSA generator .....	29
Table 4.1 – Table of Pro & cons for selection of compressor type.....	44
Table 4.2 – Correction factor on the nitrogen capacity .....	57

## List of figures

Figure 1.1- Liquefied nitrogen to left and high pressure bottle rack to the right.[1].....	9
Figure 1.2 - Hamworthy Nitrogen membrane generator for stationary use. [2] .....	10
Figure 1.3 - Chart that indicates the purpose of nitrogen supply referred to purity and flow. [3].....	12
Figure 1.4 - Overview of a nitrogen membrane generator [4].....	13
Figure 1.5 - Main components of a Nitrogen membrane .....	13
Figure 1.6 - NGM 2 from Atlas Copco, weight of 268 kg. [5] .....	14
Figure 1.7 - Illustrates how the NGM units can be installed. [5].....	15
Figure 1.8 - Branick mobile nitrogen membrane for tiers. [6] .....	15
Figure 1.9 – Electrical control cabinets on the breathing air compressor.[12].....	16
Figure 1.10 - Scroll element on the breathing air compressor. ....	17
Figure 2.1 - Containerized nitrogen membrane for use offshore from Genron.[7].....	18
Figure 2.2 - Genron Marine nitrogen membrane generator with integrated air compressors .....	19
Figure 2.3 – <i>Main components on a nitrogen membrane generator.</i> .....	21
Figure 2.4 - Illustrating the process inside the membrane [4] .....	22
Figure 2.5- Illustrating the mechanical conception of an nitrogen membrane [4] .....	23
Figure 2.6- Parker Hifluxx N2 Nitrogen membrane sizes [10] .....	23
Figure 2.7 – Illustration of the Principle of a PSA sequence. [11] .....	25
Figure 2.8- Picture of an Atlas Copco PSA generator. [5].....	26
Figure 2.9 – Illustration of Nitroswing generators from Genron [7] .....	26
Figure 3.1 – Principle from E Innovation air cooling system. [12].....	33
Figure 4.1 – Main components and the sub- components on Nitrogas generator.....	35
Figure 4.2 – P&ID of the Nitrogen generator based on scroll compressor. ....	36
Figure 4.3 – Powerex 3,7 KW scroll element from Compressor World [14] .....	37
Figure 4.4 – Hitachi 5,5 KW scroll element . [Appendix 10] .....	38
Figure 4.5 – Hitachi scroll compressor on motor base plate and 1.stg cooler.....	39
Figure 4.6 – Hitachi compressor mounted in the E compressor unit.....	40
Figure 4.7 – Concept of a 4 piston compressor with V-block [8] .....	41
Figure 4.8 – Screw compressor design. [8].....	42
Figure 4.9 – Illustration of the vane compressor concept. [15] .....	43
Figure 4.10 - 3D model of the Fini FSC 50 11KW .....	45
Figure 4.11 – Air driven high pressure booster that IKM use. ....	46
Figure 4.12 – P&ID for low and high pressure nitrogen generator.....	47

Figure 4.13 – Integrated 6 liter HP bottle.....	48
Figure 4.14 – Picture of an air driven HP booster. [16].....	50
Figure 4.15 – Bauer IK100/120 HP air compressor block. [17]. ....	50
Figure 4.16 – P&ID of the HP system with a Bauer booster compressor.....	52
Figure 4.17 – 3D model of Pacific 300 compressor block from Nardi.[18] .....	53
Figure 4.18 – HP filter form Parker.....	54
Figure 4.19 – P&ID for integrated LP an HP on common electrical motor. ....	54
Figure 4.20 – Parker ST708 nitrogen membrane [10].....	56
Figure 5.1 – Main Components of the structure of the frame.....	59
Figure 5.2 – Section of a frame structure beam.....	60
Figure 5.3 - Primary structure for the Nitrogen unit. ....	60
Figure 5.4 – Lifting padeye design for the frame. ....	61
Figure 5.5 – Main components integrated into the frame.....	61
Figure 5.6 – Main components integrated in the frame design.....	62
Figure 5.7 – Illustration of an 4 part sling that the frame is designed for[13]. ....	65
Figure 5.8 - Norsok R-002 appendix J, formulas for padeye calculation and design .....	69
Figure 5.9 – 3D model of the designed lifting pad eye.....	72
Figure 5.10 – Indication of direction of load on lifting arrangement.....	74
Figure 5.11 – Simulation with similar bolt.....	75
Figure 5.12 – Bounded conditions on the lifting arrangement .....	75
Figure 5.13 – Overall stress distribution of the analysis .....	76
Figure 5.14 – ISO clipped at 31 MPa SF=10.....	77

## Contents

Front Cover .....	1
i. Abstract .....	2
ii. Acknowledgements .....	3
iii. Notations and abbreviations .....	3
List of tables .....	4
List of figures .....	4
1. Introduction.....	9
1.1. Background.....	9
1.2. Nitrogen Generators applications for oil and gas .....	11
1.3. Why produce nitrogen on-site. ....	12
1.4. Offshore nitrogen production. ....	12
1.5. Technology on todays marked. ....	14
1.6. Description .....	16
1.7. Objectives .....	17
1.8. Organization of the work.....	17
2. Literature survey .....	18
2.1. Existing Nitrogen generators .....	18
2.2. High pressure nitrogen onsite .....	19
2.3. How nitrogen is produced on-site.....	20
2.4. Nitrogen Membrane technology.....	21
2.5. PSA (Pressure Swing Adsorption) N2 Technology .....	24
2.6. Pro and cons for membrane and PSA generators .....	28
2.7. Discussion .....	29
3. Design Criteria for the Nitrogen Generator .....	30
3.1. Design criteria.....	30
3.2. Dimensions .....	31
3.3. Capacity .....	31
3.4. Electrical components and specifications .....	31
3.5. Air purification system .....	31
3.6. Air monitoring system .....	32
3.7. Mechanical components .....	32
3.8. Directives and Harmonized Standards .....	33
4. System design and components.....	35

4.1.	Scroll compressor .....	36
4.1.1.	Hitachi scroll compressor .....	36
4.1.2.	Conclusion scroll compressor .....	40
4.2.	Alternative low pressure compressor .....	40
4.2.1.	Piston Air Compressors .....	41
4.2.2.	Screw Compressors .....	42
4.2.3.	Vane Compressors.....	43
4.2.4.	Selection Low pressure compressor.....	44
4.2.5.	LP compressor electrical motor.....	46
4.3.	High pressure and low pressure generator .....	46
4.3.1.	Selection of high pressure Compressor.....	49
4.3.2.	HP compressor electrical motor .....	53
4.3.3.	HP filter.....	53
4.3.4.	Features on HP nitrogen generator.....	54
4.4.	Nitrogen Membrane.....	55
4.4.1.	Parker ST708 Nitrogen Membrane.....	56
4.4.2.	Conclusion of Parker Membrane.....	58
4.5.	Air purification system .....	58
4.6.	Discussion for system design and components .....	58
5.	Frame.....	59
5.1.	Frame construction .....	59
5.2.	Lifting Pad eye analyze: .....	63
5.2.1.	Design criteria for the strength of the frame: .....	63
5.2.2.	Lifting shackle configuration .....	64
5.2.3.1.	Shackle calculation, according to Norsok R-002.....	66
5.3.	Pad Eye design criteria and calculation.....	68
5.4.	Simulation of lifting Padeye .....	73
6.	Conclusion and further work.....	78
6.1.	Conclusion .....	78
6.2.	Future work .....	79
7.	References.....	80
A.1.	New parts for the installation of Hitachi 5,5KW scroll compressor.....	82
A.2.	Fini Compressor FSC 50 -11KW .....	92
A.3.	Nardi HP Compressor Pacific.....	95

A.4. Parker ST708 nitrogen membrane .....	97
A.5. Air purification filters from Parker .....	98
A.6. Gunnebo Artic shackle grade 8 .....	101
A.7. Lifting padeye drawings .....	102
A.8. Main drawings for Frame 200013 .....	104
A.9. Lifting calculations from excel worksheet [22] .....	113
A.10. Hitachi 5,5 KW scroll documentation.....	114
A.11. Primary structure component 30x30 mm square pipe catalog .....	116
A.12. Datasheet for Alloy 6082-T6 .....	117
A.13. P&ID on system configuration .....	118



# 1. Introduction

## 1.1. Background

Nitrogen is used in various operations in the oil & gas installations worldwide. There are two main sources for nitrogen on an installation.

- Onboard/onsite nitrogen generator that produce a specific volume.
- Nitrogen that is transported to offshore installation, as cooled liquefied nitrogen or high pressure nitrogen in bottle rack.

Nitrogen is used in many various operations in the oil and gas industry. From Daily operations as drilling and oil production, to well completions and well intervention jobs, pressure testing, flushing, pipe-drying and maintenance operations.

Since the Nitrogen can now be produced offshore, it's more common to use nitrogen for more applications on the offshore installations.

Before nitrogen generators were common, nitrogen had to be shipped with supply boats to the installation, causing high logistics impact and expensive to use.

Figure 1.1 shows the typical transport cartridge for transporting liquefied and high pressure bottle racks with nitrogen.



Figure 1.1- Liquefied nitrogen to left and high pressure bottle rack to the right.[1]

Nitrogen produced on an installation now is mainly designed for few specific applications. Due to the size and that the generators are stationary, not all of the operations or applications can be served from one nitrogen generator.

Figure 1.2 shows a Hamworthy Moss Nitrogen membrane generator for stationary use. This is only the generator without air compressor or nitrogen receiver vessels.

An example where it is now more common to use nitrogen now is for inert gas. Earlier, CO<sub>2</sub> was generated to use as inert gas, resulting in high consumption of fossil fuel. Now a smaller and more effective nitrogen generator can be used for inert gas.

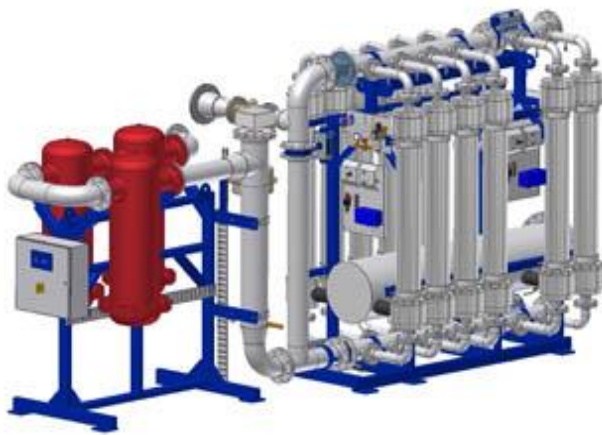

Figure 1.2 - Hamworthy Nitrogen membrane generator for stationary use. [2]

## 1.2.Nitrogen Generators applications for oil and gas

### **Oil installations**

- Instrument Panels
- Gas Compression Seals
- Degassing plant
- Sump tank for oily water in the hazardous area
- Hose outlet
- Methanol tank
- Expansion tank for coolant
- Dry Bulk Transfer
- Riser Tensioner
- Heave Compensators
- Inert gas

### **BOP**

- Closure Devices
- APV Bottle Filling

### **Maintenance and modifications**

- Pressure testing
- Pedestal Blanketing
- Cementing Storage
- Drive gas for pigs through pipelines.

### **Drilling Support/LWI**

- Cementing operations
- Completion operations
- Maintain pressure in reservoirs
- Well Clean Out
- Gas Lift
- Well fracking

### 1.3. Why produce nitrogen on-site.

Dependent on purity, flow rate and a number of other considerations there are many options to supply nitrogen. Figure 1.3 indicates the optimal supply option when nitrogen is considered as an option. Indicate that membrane generators are optimal for use when the demand is from approx. 1-600 Nm<sup>3</sup>/h. and purity up to 97%. Also indicate when purity up to 99%, the membrane is optimal up to approx. 50 Nm<sup>3</sup>/h.

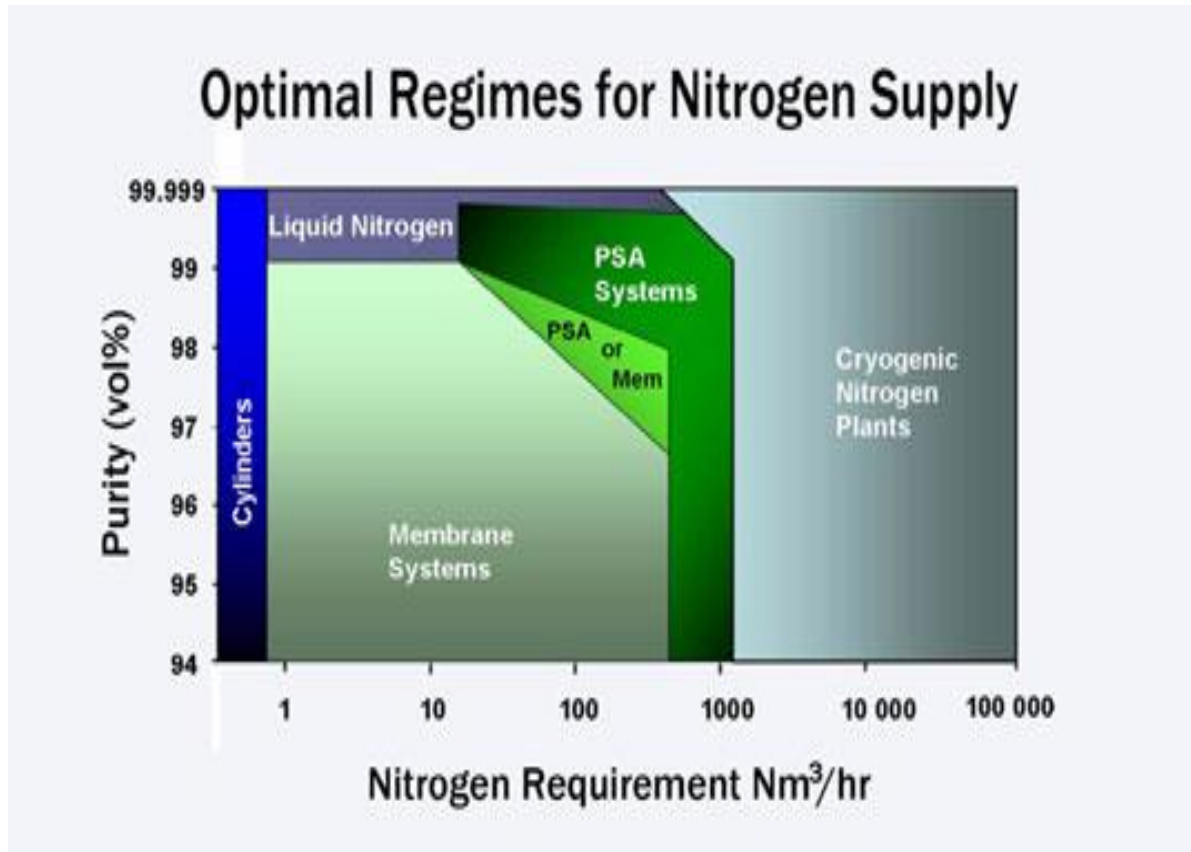

Figure 1.3 - Chart that indicates the purpose of nitrogen supply referred to purity and flow. [3]

### 1.4. Offshore nitrogen production.

Generally there are two ways to make on-site nitrogen.

- PSA (Pressure Swing Absorption)
- Nitrogen Membrane Generators.

These generators are normally mounted on a stationary skid in the process area or in the utility area of the installation. Normal practice for stationary nitrogen generators is that they receive compressed air from “platform airline” or having an external compressor that supply compressed air.

Produced nitrogen is then supplied to the different users around the installation at low pressure in pipes. Figure 1.4 is showing a typical overview of a nitrogen membrane generator.

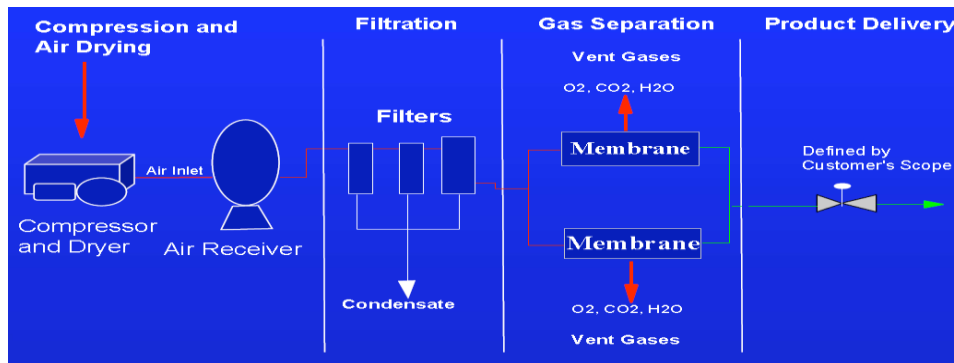

Figure 1.4 - Overview of a nitrogen membrane generator [4].

Main Components:

- Air compressor. Low pressure air compressor that can supply continually air to the generator. Air compressors are normally screw or piston compressors.
- Air treatment system. Due to the specified cleanness of the inlet air to the nitrogen generator, filtration system is an essential part of the system. Water, oil and dust filtration is the main function for the air treatment.
- Nitrogen membrane/PSA. Flow and purity of the specified nitrogen is the key factors for choosing between PSA or Membrane solution.

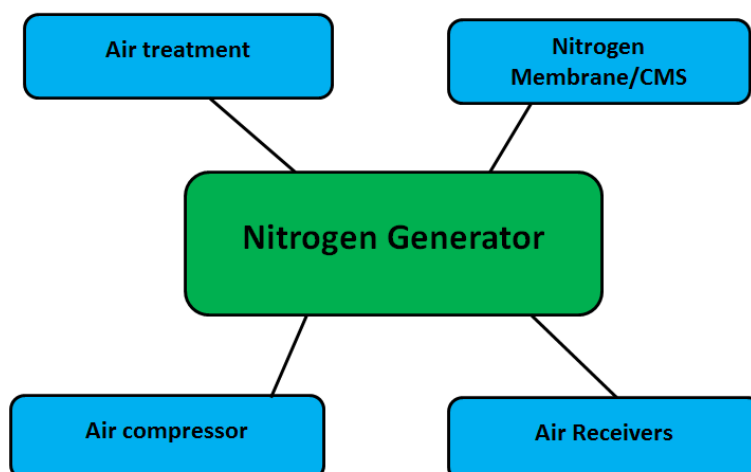

Figure 1.5 - Main components of a Nitrogen membrane

### 1.5. Technology on today's market.

On the market today there are many manufacturers and suppliers of nitrogen generators for the oil and gas industry. Common factors for these are that they are stationary module or container modules that are designed to generate as much nitrogen as possible from 50-5000 Nm<sup>3</sup>/h per hour, normally with low pressure and then an external booster option.

There are no suppliers that can supply a manual portable nitrogen unit that can generate nitrogen without air supply from the vessel/platform in Atex zone 1.

The nearest that is on the markets that are compact and modern solution are nitrogen membranes in a prefixed cabinet, for permanent installation. These cabinets are “plug and play”, where they only need air supply and electrical power. But these are not for Atex zones. Figure 1.6 illustrates an NGM 2 unit from Atlas Copco that can with a design point of 24,1 Nm<sup>3</sup>/h nitrogen.



Figure 1.6 - NGM 2 from Atlas Copco, weight of 268 kg. [5]

These are simple to installed and connect to existing nitrogen lines, but they are not mobile. Inlet pressure of 8 bar, generate an outlet nitrogen pressure of 6,5 bar(g).[5]



Figure 1.7 - Illustrates how the NGM units can be installed. [5]

Nearest portable nitrogen generator is units made for inflating tiers on commercial vehicles. An example for this is Branick 685 figure 1.8. These units are as the NGM modern in a cabinet and built as “plug and play”. Need compressed air and electrical power. This has a lower capacity NGM, but instead they are portable. Not qualified for oil and gas industry or installations. The capacity is form 2-30 Nm<sup>3</sup>/h @ 10 bar(g).[6]



Figure 1.8 - Branick mobile nitrogen membrane for tiers. [6]

## 1.6. Description

Nitrogas As is a daughter company of E innovation is starting to develop a portable Nitrogen generator for use in Atex zone 1.

E Innovation has for the time being a mobile air compressor that supply controlled breathing air in Atex Zone 1. This compressor is based on an electrical driven oil-free scroll compressor, air cooling arrangement from E innovation and air treatment package from Dunomick Hunter. These insure that the compressed air is according to ISO 8573.1.

E-compressor is provided with online measurement of the quality of the air.

Nitrogen generator will use some of the principles and components from the E compressor. Figure 1.9 is the electrical cabinets and interface on the E compressor. This telemetry and electrical components are something that can be implanted on a Nitrogen generator unit.

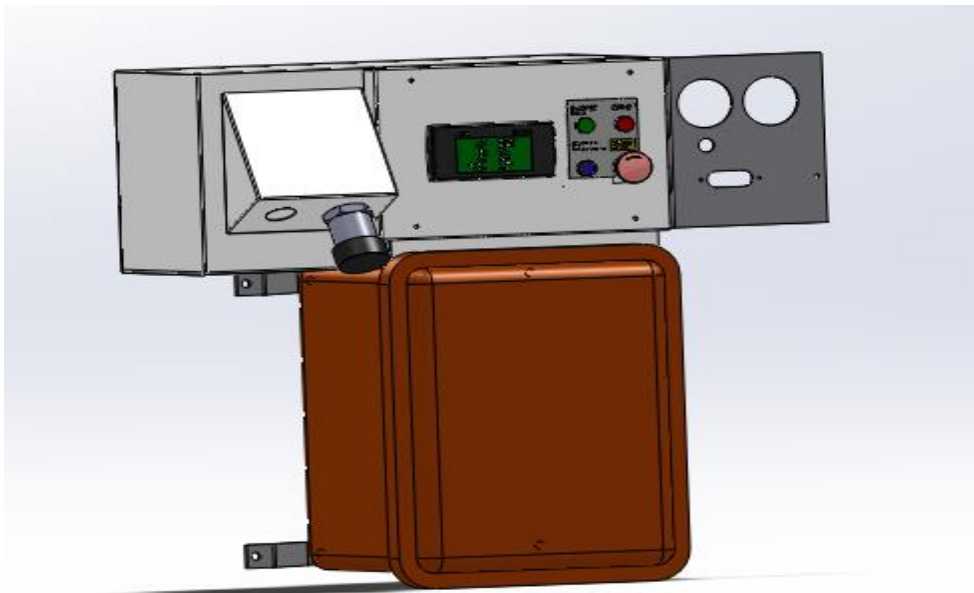

Figure 1.9 – Electrical control cabinets on the breathing air compressor.[12]

Figure 1.10 illustrates the drawing of the scroll compressor that is installed on the E compressor today. This compressor is delivering 400 l/min. New scroll compressor from Hitachi will have a capacity of 650 l/min.



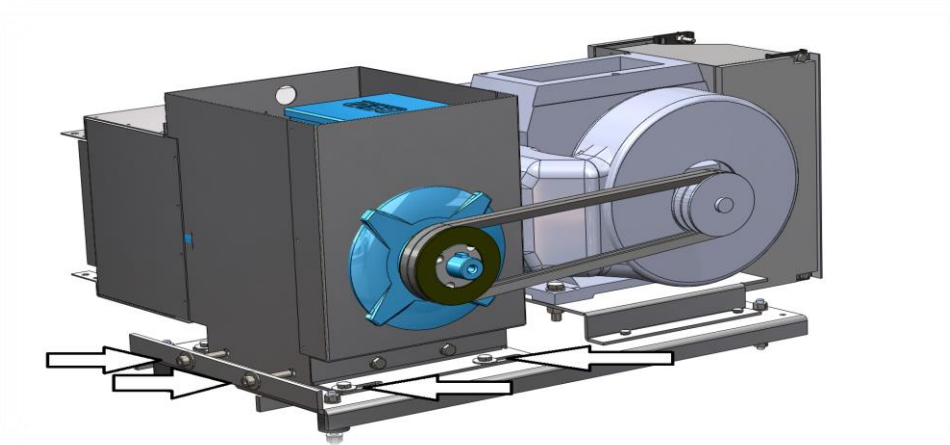

Figure 1.10 - Scroll element on the breathing air compressor.

## 1.7. Objectives

The objective for this master thesis will be to investigate the possibility of developing a suitable portable Nitrogen generator for use on offshore installation. The work will comprise defining the system functional requirements for such a unit. Several possible design solutions will be identified and then screen based on commercial and technical requirements. The overall objective will be to develop an easy to use "plug & play" unit utilizing only electrical power supply. The thesis will not only cover the design of the processing equipment but also cover the design for the primary structure including lifting arrangement using 3-D modeling, calculations and analyzing. A main challenge will be to fully understand the applicable standard regulation such a unit in an offshore environment.

## 1.8. Organization of the work

This chapter contains a brief introduction about nitrogen generators and existing products and solutions.

Chapter 2 is a literature survey of existing nitrogen generators and the main functionality of these, and are discussed and evaluated to the specification of the nitrogen generator that Nitrogas will develop.

In chapter 3 the design criteria for the Nitrogas nitrogen generator is presented. All main components is discussed.

Chapter 4 is where the main components and system where configured for construction of prototype.

In chapter 5 is where the primary structure of the frame and lifting arrangement is designed.

Chapter 6 is the conclusion along with suggestions for further progress and work with the Nitrogas nitrogen generator.

## 2. Literature survey

There are several manufacturers and suppliers of Nitrogen generators for use on oil installations. Common for this is that they are mounted stationary or in a container.

But in the last few years there has been an huge development of nitrogen generators that are smaller, cabinet based and easy to integrate, but they are still stationary.

### 2.1.Existing Nitrogen generators

Figure 1.5.1 is a nitrogen membrane unit with external air compressor and air tank for production of onsite nitrogen in non-hazardous environment, from Atlas Copco. This is an example of how nitrogen generators are designed for easy installation and use.

GENERON® IGS is one of the biggest companies of separation membrane technology for generating onsite nitrogen gas. They are delivering onsite production facilities for nitrogen production, also in Atex zone 1, but they are not portable and they require air supply. [7]

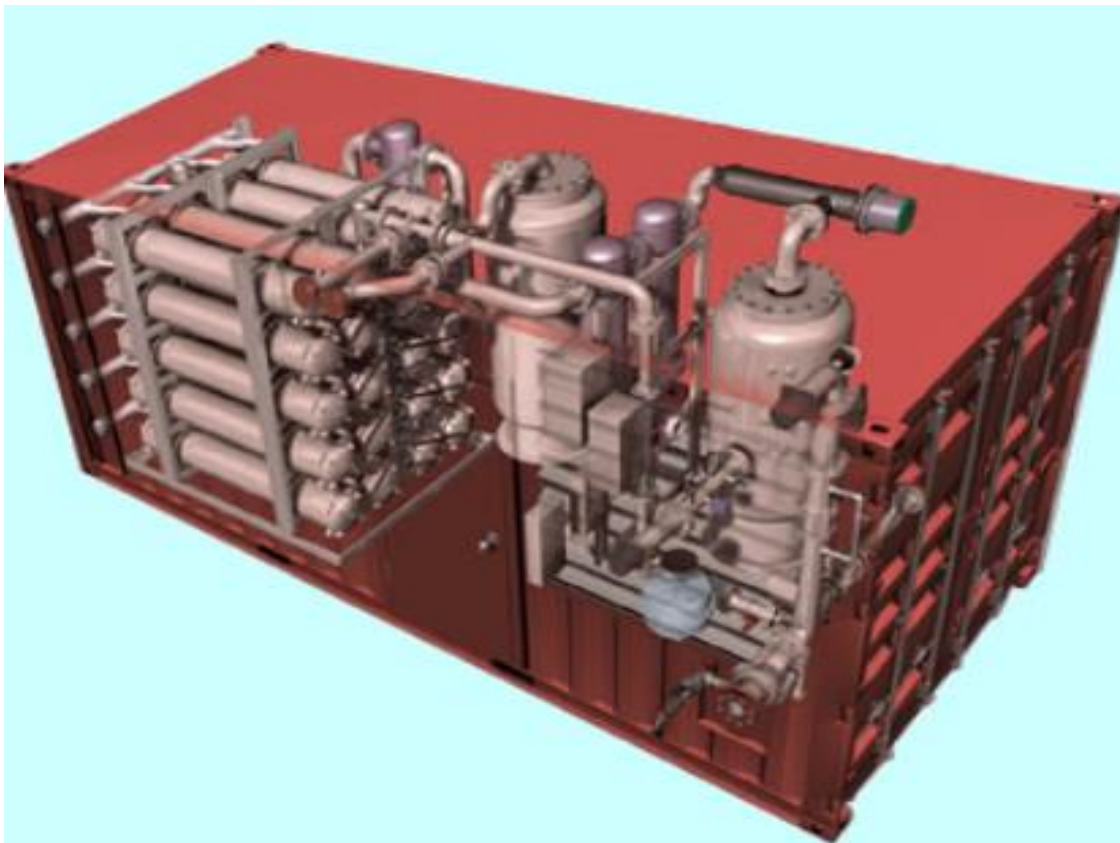

Figure 2.1 - Containerized nitrogen membrane for use offshore from Genron.[7]

Figure 2.2 is a picture of a Genron onsite nitrogen membrane generator with integrated air for marine used. Genron can also supply high pressure N2 booster to connect in series with the

nitrogen generators. I have not found any documentations of on this, but on the website, they claim that they have N2 boosters.



Figure 2.2 - Genron Marine nitrogen membrane generator with integrated air compressors

## 2.2. High pressure nitrogen onsite

As mention there are many types of applications on an oil installation where nitrogen is used, several of these applications require high pressure nitrogen. Majority of companies are currently using high pressure cylinders/bottle racks for these applications. The biggest problem is not being able to use all of the gas from the bottle racks. If you require 150 bar and are using 300 bar bottles you are sending back almost half of the unused nitrogen. A way to eliminate this problem is to incorporate high pressure nitrogen boosters in house. With an portable Nitrogen generator that are delivering pressure from 10-300 bar from produced on-site nitrogen, it will not be necessary to send half full bottles back onshore. Also it is not necessary to have so many bottle racks for each job. [8]

Other benefits for on-site nitrogen productions are:

- Lower transport cost of nitrogen.
- Nitrogen on-site when you need it.
- Nitrogen production anywhere on the oil installation, also Atex zone 1.
- Compact size, easy to use.

### 2.3.How nitrogen is produced on-site.

Normal air consists of approx. 78% nitrogen, ca. 21% oxygen and about 1% noble gases.

Generally there are two ways to make on-site nitrogen.

- PSA (Pressure Swing Absorption)
- Nitrogen Membrane Generators.

Flow rates and purity will determine which technology is best suited for the application. The PSA method of gas separation can be used to separate Nitrogen. Compressed air fed through these absorbent materials, letting the desired elemental gas pass through.

Common for both technologies is that compressed air quality into the nitrogen generators has to be compressed air quality, ISO8573-1:2010 class 1-4-1. Where the Particulate Class would be 1, the Water Class would be 4, and the Oil Class would be 1. Indicate that the oil and particles content are most important.

Nitrogen quality is typical ISO8573-1:2010 class 1-2-1.

PSA nitrogen generators are generally used in applications where the purity requirement is higher than 99.5% (0.5% O<sub>2</sub> or below). [8]

Nitrogen membrane generators work a little differently. The understanding behind nitrogen membrane generators is the different gases in the air will pass through cylindrical formed polymer film at different rates, due to the permeability for each gas. This polymer membrane separates nitrogen, a “slow gas”, from the faster gases, such as O<sub>2</sub>, Argon and other undesired product impurities.

Membrane nitrogen generators are typically used in applications where the purity requirement is below 99.5% (0.5% O<sub>2</sub> or higher). [8]

These generators have proven to be efficient and very cost effective. Because the pressure off the outgoing nitrogen from the membrane is almost the same as the inlet compressed air pressure. (Small pressure drop over the membrane)Very little, if any, additional sources of air compression are required.

## 2.4. Nitrogen Membrane technology

- Optimal purity range: 90% to 99.0%
- Optimal flow rate: 1-600 Nm<sup>3</sup>/h
- Startup time of 30-60 seconds
- Compressed air inlet quality ISO8573-1:2010 class 1-4-1

Nitrogen Membrane technology was developed by Dow Chemical Company in the mid 1980's using a hollow polymeric fiber. The first membranes were spiral wound, today's technology use hollow fiber membranes. This allows the greatest possible surface area for gas separation in compact size. [9]

Main components on a nitrogen generator are listed in figure 2.3.

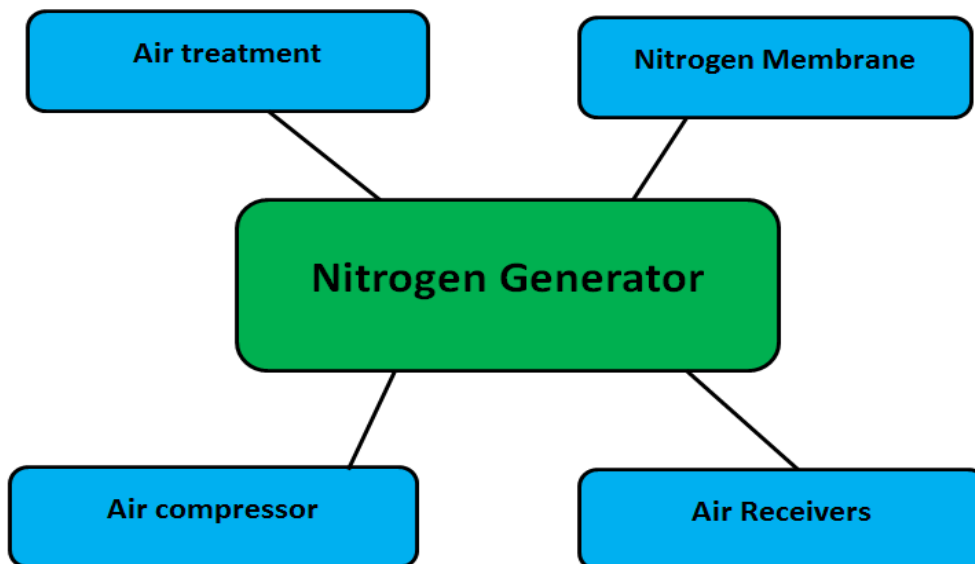

Figure 2.3 – Main components on a nitrogen membrane generator.

- Air compressor. Typically screw or piston compressor.
- Air treatment that separate water dust and particles down to ISO 8573.1 according to membrane manufacture requirements.
- Nitrogen Membrane can be in serial or parallel with several membranes. According to the specific design criteria on flow and purity.
- Air receivers, nitrogen goes into a tank receiver or straight to consumer.

The driving force for the exchange of gases is the partial pressure difference of the gases on either side of the membrane. Filtered compressed air up to 40 bar (g) is supplied into these small thin fiber tubes, the following occurs: [9]

1. Carbon dioxide, oxygen and water vapor will easily through the thin walls of the tube because of the molecular size and are then directed to the vent in a safe area.
2. The rest of the air is getting more and more enriched in nitrogen and need not easily leak out through the thin walls of the fibers. While the oxygen is diffused to the outside, the nitrogen molecules remain in the hollow fiber. Due to the difference in partial pressures on the internal and external membrane surface, gas flow separation is achieved. Oxygen, water, CO2 and Argon is separated from the Nitrogen and nitrogen is flowing out of the center of membrane end.
3. The nitrogen can also be passed through a vessel containing activated charcoal. The charcoal absorbs oxygen and then one will get out cleaner nitrogen. Or directly to a nitrogen receiver or consumer. Purity of the produced nitrogen may vary between 95% and 99.5%. Increased amount of membrane modules and treated air are needed for producing nitrogen at higher purity.

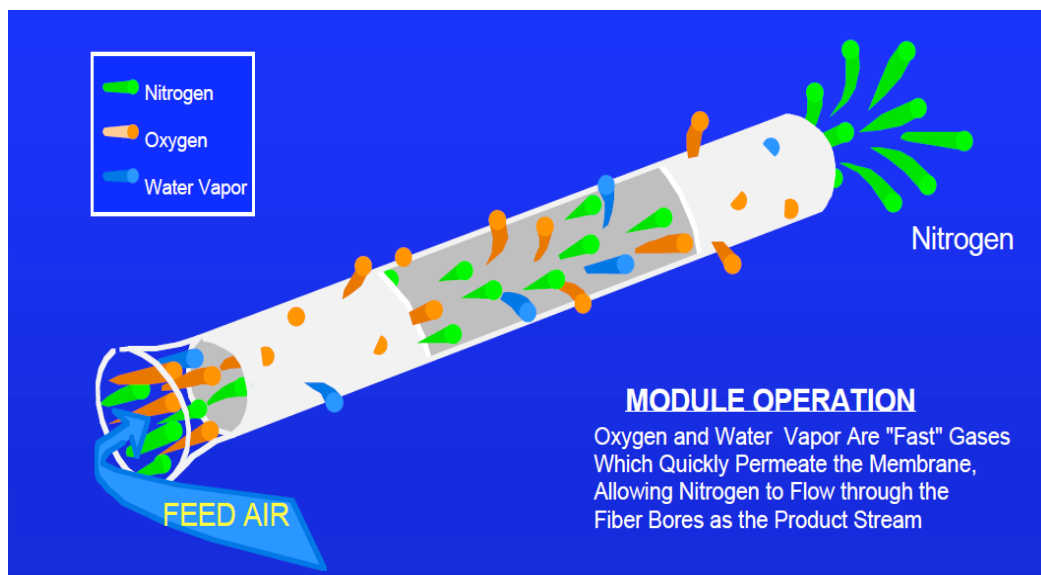

Figure 2.4 - Illustrating the process inside the membrane [4]

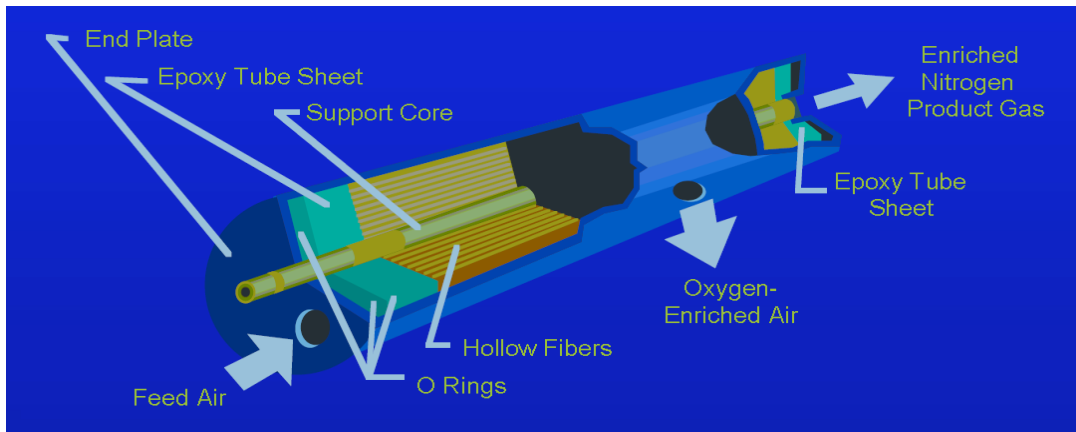

Figure 2.5- Illustrating the mechanical conception of an nitrogen membrane [4]

**Benefits:**

- Simple to use. Eliminates the need for nitrogen cylinders.
- Continuously stable flow, purity and pressure.
- Low maintenance. No moving parts.
- Lightweight and compact.
- Adjustable purity. Flow, temperature and pressure variables allow the membrane to generate up to 99.9% purity.
- Robust membranes, which can withstand oil vapor as well as liquid water.
- Typically lighter and smaller than PSA systems for production of 95% N<sub>2</sub>.
- Very small systems require less engineering and may be slightly more affordable or similar to PSA.

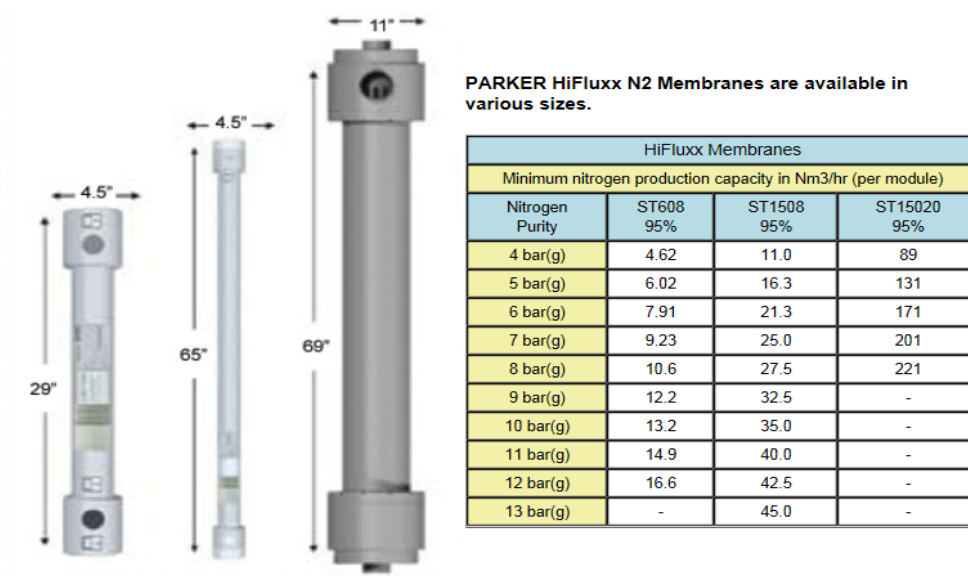

Figure 2.6- Parker Hifluxx N2 Nitrogen membrane sizes [10]

## 2.5.PSA (Pressure Swing Adsorption) N2 Technology

The second type of on-site nitrogen is PSA (Pressure Swing Adsorption) Technology.

Pressure Swing Adsorption (PSA) nitrogen generation technology is considered the mature technology and was developed in Europe in the early 1960's. [9]

PSA generator is using a pressure swing dryer concept, using two container system containing carbon molecular sieve (CMS) to separate nitrogen gas from air by absorbing (adhering) the oxygen, CO<sub>2</sub>, and water molecules onto the surface of the CMS with pressurized clean air.

- Range purity: 99% to 99.995%
- Flow rate: 1-1000 Nm<sup>3</sup>/h
- Startup time 30 minutes
- Compressed inlet air quality, ISO8573-1:2010 class 1-4-1

PSA nitrogen generators are generally used in applications where the purity requirement is higher than 99.5% (0.5% O<sub>2</sub> or below).

PSA technology is using two cylindrical formed containers that are filled with CMS. Compressed air flows from bottom of cylinder and through the CMS.

Oxygen and other gases are preferentially adsorbed by the CMS, allowing nitrogen to pass through. After a pre-set time the on-line cylinder module, it will automatically switches to the regenerative mode, venting contaminants from the CMS.

CMS differs from ordinary activated carbons as it has a much narrower range of pore openings. This allows small molecules such as O<sub>2</sub> and Argon to penetrate the pores and separate from nitrogen molecules which are too large to enter the CMS. [11]



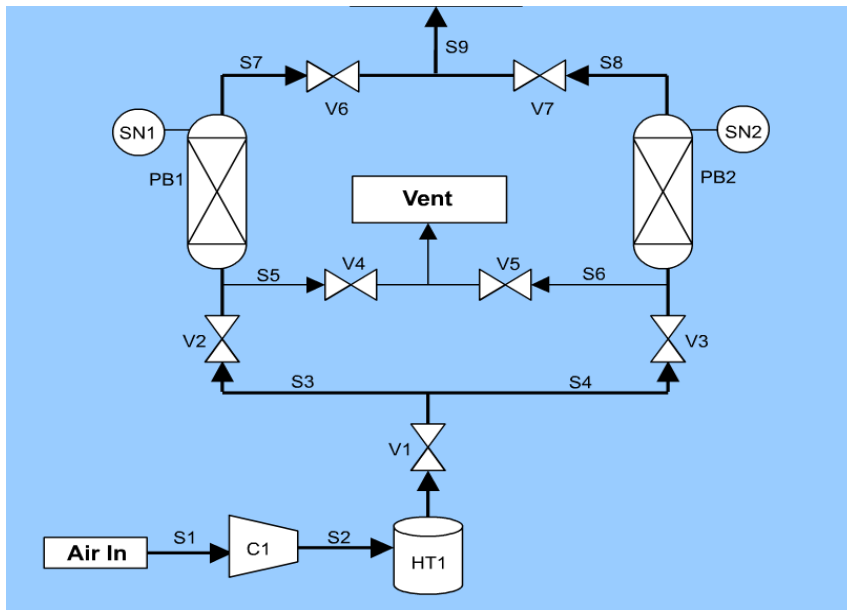

Figure 2.7 – Illustration of the Principle of a PSA sequence. [11]

1. Air enters the air compressor C1 at 1 atm.
2. Compression of the air to approx. 7 bar (g). S2
3. Compressed air flow through the cooling stage and into the air filter(s). HT1
4. Main valve V1 is operated.
5. Valve V2 is opened. Compressed air is directed to one of the CMS tubes (absorber 1) at a specified time, approx. 2 minutes. Or by measuring the N2/Ar composition reaches desired purity.
6. V2 closes, and the compressed air is feed into the other CMS tube (absorber 2).
7. V3 open, absorber 2 is getting feed with compressed air until the N2/Ar composition reaches desired purity.
8. Valve V6 on the top of the first absorber 1 opens and let the nitrogen flow to a storage tank.
9. After the nitrogen is released to the storage tank, dump valve, V4 is opened at absorber 1 and it gets depressurized and O2 desorbs.
10. Valve V3 on the absorber 2 is closed. And bottom valve V2 on absorber 1 is opened.
11. Valve V2 on top of absorber 2 is opened and let the nitrogen flow to a storage tank.
12. Stage 5 is repeated.

PSA are available in various applications and sizes, figure 2.8 is an NGP-15 generator from Atlas Copco that supply 15 Nm<sup>3</sup>/h and 99,5% purity with an air consumption of 54,3 Nm<sup>3</sup>/h. indicates an ANR (Air Nitrogen Ratio) of 3,62. [5]



Figure 2.8- Picture of an Atlas Copco PSA generator. [5]

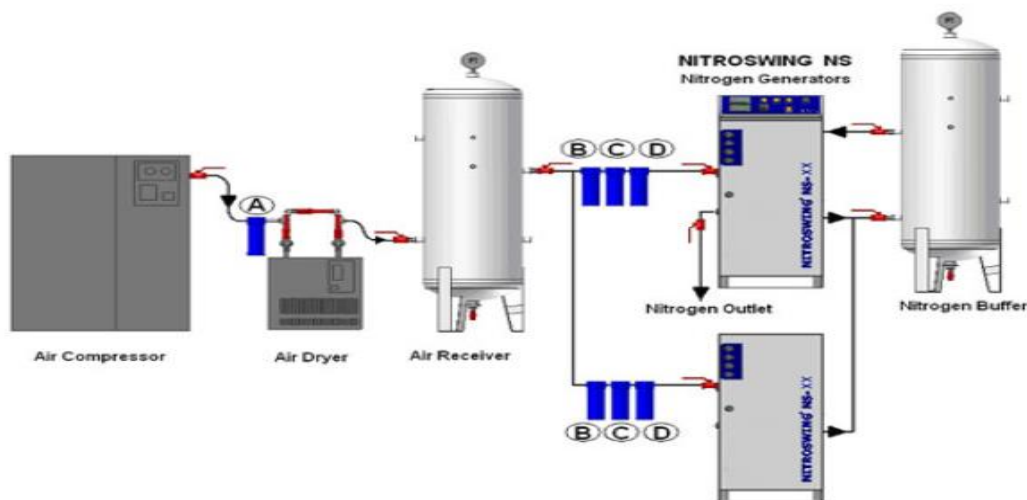

Figure 2.9 – Illustration of Nitroswing generators from Genron [7]

Each NITROSWING modular PSA nitrogen generator can easily be upgraded at any time simply by adding modules or by installing a so-called Dual-Bank in parallel without additional modifications. Figure 2.9 is a principle of this,

A Dual-Bank is a PSA nitrogen generator identical to the standard NITROSWING, but without PLC and power supply, and which will be installed parallel to the standard generator. The Dual Bank will get its power and control signals from the NITROSWING through a single cable connection (master/slave principle). [7]

Benefits:

- On-site production of Nitrogen at given flow.
- High production flow at high purity.
- Significantly more efficient than membrane technology when nitrogen purity exceeds 99%.
- PSA systems maintain much more capacity as purity requirement increases.
- For most flow/purity requirements, PSA systems will typically have greater capacity than membrane systems of similar cost.
- Replacement cost of CMS is less than  $\frac{1}{4}$  of membrane technology at 95%. [10]

## 2.6.Pro and cons for membrane and PSA generators

<b>CONCERNS</b>	<b>MEMBRANE</b>	<b>PSA</b>
<b>Flow, Purity, Pressure:</b>	Continuously stable flow, purity and pressure.	Startup time of approx. 30 minutes. Fluctuations on the flow, pressure and purity during the production. Needs for Nitrogen receiver tank.
<b>Purity Range:</b>	Effective at purities up to 99.9% (Max 0.1% O <sub>2</sub> ).	Effective at purities up to 99.999% (Max 10 ppm O <sub>2</sub> )
<b>Operating Cost:</b>	Slightly less efficient than PSA at purity a bow 99%. But comparable at purity below 99%.	Significantly more efficient than membrane technology when nitrogen purity exceeds 99%.
<b>Capacity vs. Purity:</b>	Capacity drops off significantly as purity requirement increases.	PSA systems maintain much more capacity as purity requirement increases.
<b>Initial Investment:</b>	Small requirements for the system and engineering. Less components and size on purity below 99%.	At high purity and flow, PSA systems will give more capacity for the same cost. But the total size on the system will be bigger.
<b>Water Sensitivity:</b>	Tolerates water liquid and vapor in the inlet air. Condensate will temporarily reduce capacity, until membrane dries.	PSA Systems require dry air. Carbon Molecular Sieve (CMS) is sensitive to water in all forms and capacity will decrease temporarily if exposed, or possibly permanently.
<b>Oil Sensitivity:</b>	Field-proven, robust membranes, which can withstand oil vapor as well as liquid water.	Contamination of CMS with oil causes permanent and irreversible decline in performance.

CONCERNS	MEMBRANE	PSA
<b>Replace Membrane/CMS</b>	Higher cost of changing Membrane than CMS.	Replacement cost of CMS is less than ¼ of membrane technology at 95%.
<b>Useable life:</b>	Low maintenance. No moving parts.  Simple to use.	Valves is opening and closing during the production. For Each cycle between the CMS, several valves have to open and close.
<b>Scheduled Maintenance:</b>	Replace air treatment filters 1-2x per year.	Replace air treatment filters 1-2x per year.
<b>Weight:</b>	Lighter and smaller than PSA systems for production of 95% N2.	Heavier and bigger than membrane for production of 95% N2. May be lighter at higher flow and purity.
<b>Size:</b>	Typically smaller than PSA systems for production of 95% N2.	Typically larger than membrane for production of 95% N2. May be smaller at higher flow and purity.

Table 2.1- Table of pros and cons for Membrane and PSA generator

## 2.7.Discussion

In the literature survey the most common membrane generators and PSA generators have been discussed. The result of the study is that the existing technology on nitrogen generators is getting more efficient and smaller. But the companies that are developing nitrogen units are not considering having any options with fully manual portable nitrogen unit.

The manufactures and OIM that supply nitrogen generators with integrated air compressor are based on container or skid mounted solutions.

A nitrogen membrane seems like the best option for Nitrogas portable nitrogen unit, due to size, purity of 95% and low flow.

### 3. Design Criteria for the Nitrogen Generator

The Nitrogen generator will be designed to deliver nitrogen from 200 l/min@ 5-8 bar (a) in ATEX zone 1. The system is mobile allowing the user to move the nitrogen generator by hand from location to location.

#### 3.1.Design criteria

One of the fundamental design aspects was the size. A typical “portable” nitrogen generator is a 4te, 10ft container. Nitrogas goal is to design and produce a “trolley” that could deliver nitrogen @ 200-500 l/min and that could move on wheels by the hand of the operator and could easily be operated in all working areas including Atex zone 1.

IKM was involved for information regarding the features that IKM wanted to have implanted in a portable nitrogen generator.

Summary of design criteria:

- Designed for Atex Zone 1
- According to Directives and Harmonized Standards.
- Designed for manual transport at deck.
- Maximum weight of 400 kg.
- Maximum width of 0,80 m. (door opening)
- Producing minimum 200 NI/min with Nitrogen @ 95 % purity.
- Discharge pressure up to 2-8 bar (a).
- Minimum discharge pressure 40-70 bar (a). (IKM)

The design process was initialized and planning to adapt some of the components used on the E compressor, as scroll compressor, motor, filters etc. And then new components and parts will be searched for and applied to the nitrogen generator. The design phase is split into 6 main categories.

- Dimension
- Capacity
- Electrical components
- Air purification system
- Air monitoring system
- Mechanical components

All categories had common challenges to be in compliance with standards and regulations for the intended final product and specifications. All components had to be capable of delivering the capacity needed to operate the system and still be within the maximum weight of 400 kilos.

### **3.2.Dimensions**

The generator was intended for use in all situations. This included moving through narrow spaces as elevators and doorways. To be able to enter cantilever decks, it was necessary to design the compressor with a maximum width of 800 mm, desired length of 1200mm and height of 1200mm. Preparation for internal lifting on an installation, by using a 4 part wire sling assembly and lifting points.

### **3.3.Capacity**

The nitrogen generator will be designed to supply nitrogen of 200 l/min, pressure of 5-8 bar (g) and 95% purity.

### **3.4.Electrical components and specifications**

Nitrogas is planning to use some of the components and control unit that has been designed by Oneco for E Innovation on the E Compressor.

All components used in the construction have to be CE marked and in accordance to directives and applicable harmonized standards. (Atex)

### **3.5.Air purification system**

The E Compressor is equipped with a complete air purification unit from Domnick Hunter. For production of Nitrogen, it's essential that the filtration of the air entering to the Nitrogen membrane is free off particles and oil.

Have to be according to ISO8573-1:2010 class 1-4-1, the international standard of compressed air quality. [10]

Filtration of the compressed air will be according to specifications from nitrogen Membrane manufacture.

### 3.6. Air monitoring system

At the air inlet the air has to sample to detect any traces of Methane  $\text{CH}_4$  gas. If any traces are read at the detectors the system is shut down before the air reaches the compressor unit. The second part of the monitoring system, constantly detects the following parameters of the produced nitrogen  $\text{O}_2$  (indicate the nitrogen content) and dew point. A pilot of air is led to a chamber that keeps a low overpressure and the air is sampled through separate sensors. If the values come out of the acceptable range, settled by the standards, the operator will receive a light and sound warning and finally the system shuts down when the nitrogen quality is no longer acceptable.

### 3.7. Mechanical components

The selection of mechanical components will be based on well-known products that have been on the market in a variety of applications for years. All components and parts that will be used, has to have certification according to CE, machinery directive.

As the main component of the Nitrogen generator will be the modification of the scroll element that are used in the E compressor. Hitachi oil free scroll has been on the market for many years and is seen as an effective air compressor in addition to its oil free properties. One of the challenges with the scroll compressor is the need for cooling of the compressed air. The installation of traditional cooling stages including fans, motors and control equipment, would have increased the total weight. Figure 3.1 is showing how E Innovation AS came up with solution to use the internal fans in both scroll compressor element and the electrical engine that powers the compressor, to cool down the compressed air through two air cooling radiators.



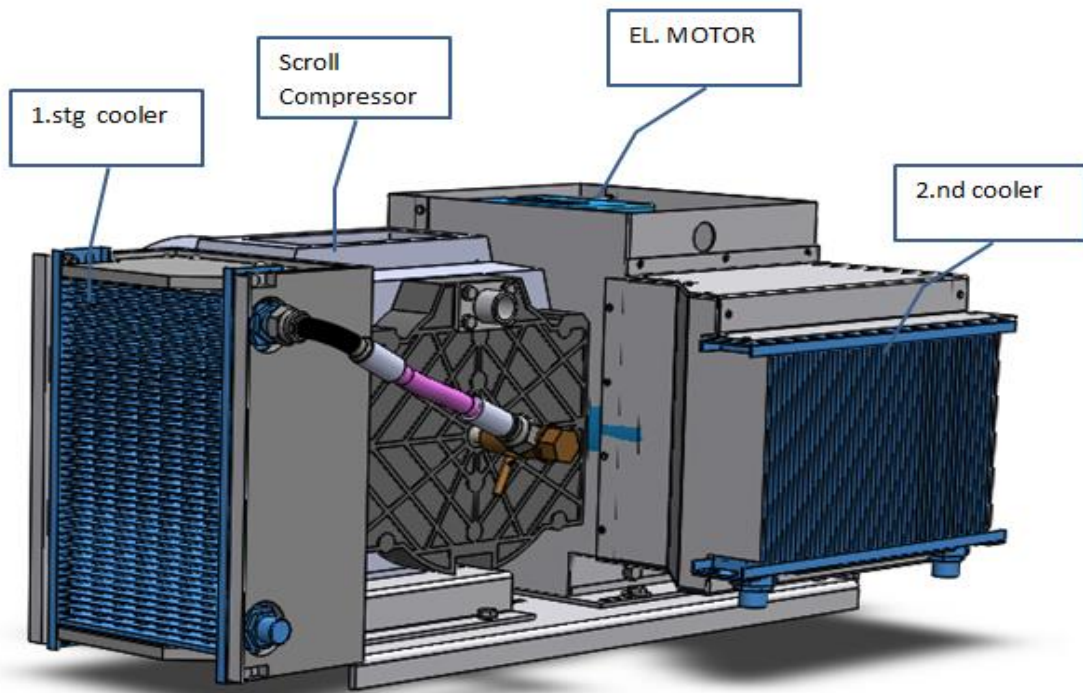

Figure 3.1 – Principle from E Innovation air cooling system. [12]

### 3.8. Directives and Harmonized Standards

This is a list of several directives that can be involved during the design and production of the Nitrogen Generator. The main focus during the design will always be to comply with directives and applicable harmonized standards.

#### Directives

Nitrogen Generator has to be compliance with the following Directives:

- |            |  |
|------------|--|
| 94/9/EC    | Conforms to the Essential Health and Safety Requirements of the Equipment in Explosive Atmospheres (ATEX) Directive. |
| 2006/42/EC | Conforms to the Essential Safety Requirements of the Machinery Directive.  |

### **Harmonized Standards**

Nitrogen Generator has to be designed and manufactured to the relevant parts of the following harmonized standards:

NORSOK R-002	Lifting equipment, Edition 2, September 2012
DNV 2.7-3	Portable Offshore Units, May 2011
NORSOK Z-015	Temporary equipment, nr 4, September 2012
EN 12079-2:2006	Offshore containers and associated lifting sets
EN 13463-1: 2009 (E)	Non – electrical equipment for use in potentially explosive atmospheres Part 1: Basic methods and requirements.
BS EN ISO 12100:2010	Safety of machinery - General principles for design – Risk assessment and risk reduction
EN 953:1997+A1:2009	Safety of machinery - Guards - General requirements for the design and construction of fixed and movable guards

#### 4. System design and components

Literature survey and design criteria are the main fundament to start design of the system in early phase. System design is making the foundation and guidelines for the configuration of main basic components for construction of a portable nitrogen generator. List below is illustration the main components and sub-components are indicated in Figure 4.0.

Appendix A.13 is system overview drawing (P&ID) for several solutions that has been designed and discussed during the system design phase.

Main components in the nitrogen generator are listed as.

- Frame.
- Nitrogen Membrane.
- Low pressure compressor with electrical motor.
- High pressure compressor with electrical motor.
- Air treatment components.
- Atex Electrical Controller.

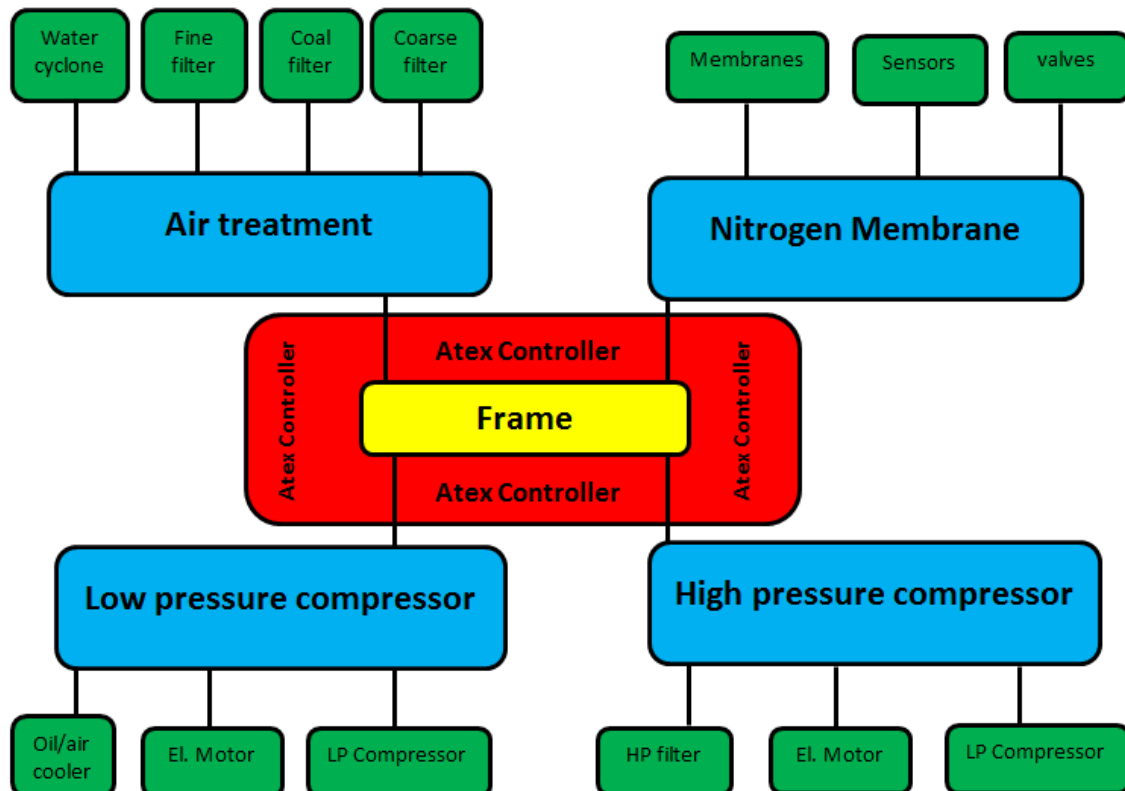

Figure 4.1 – Main components and the sub- components on Nitrogas generator.

## 4.1. Scroll compressor

As mention in chapter 1, the construction of the nitrogen system was based on the E compressor.

E compressor is based on a 3,7 KW scroll compressor from Compressor world, manufactured by Powerex, with a capacity of 400 l/min and 8 bar (g). Giving an proximally efficiency of,

$$Efficiency = \frac{400 \text{ l/min}}{3,7 \text{ KW}} * 60 \text{ min} = 6487 \frac{\text{l}}{\text{kwh}} @ 8\text{bar}(g)$$

### 4.1.1. Hitachi scroll compressor

Due to the air flow capacity on the E compressor, it was replaced by a 5,5 KW Hitachi scroll compressor with a design capacity of 600 l/min and 8 bar (g). Figure 4.2 is P&ID based on the Hitachi scroll element.

$$Efficiency = \frac{600 \text{ l/min}}{5,5 \text{ KW}} * 60 \text{ min} = 6764 \frac{\text{l}}{\text{kwh}} @ 8\text{bar}(g)$$

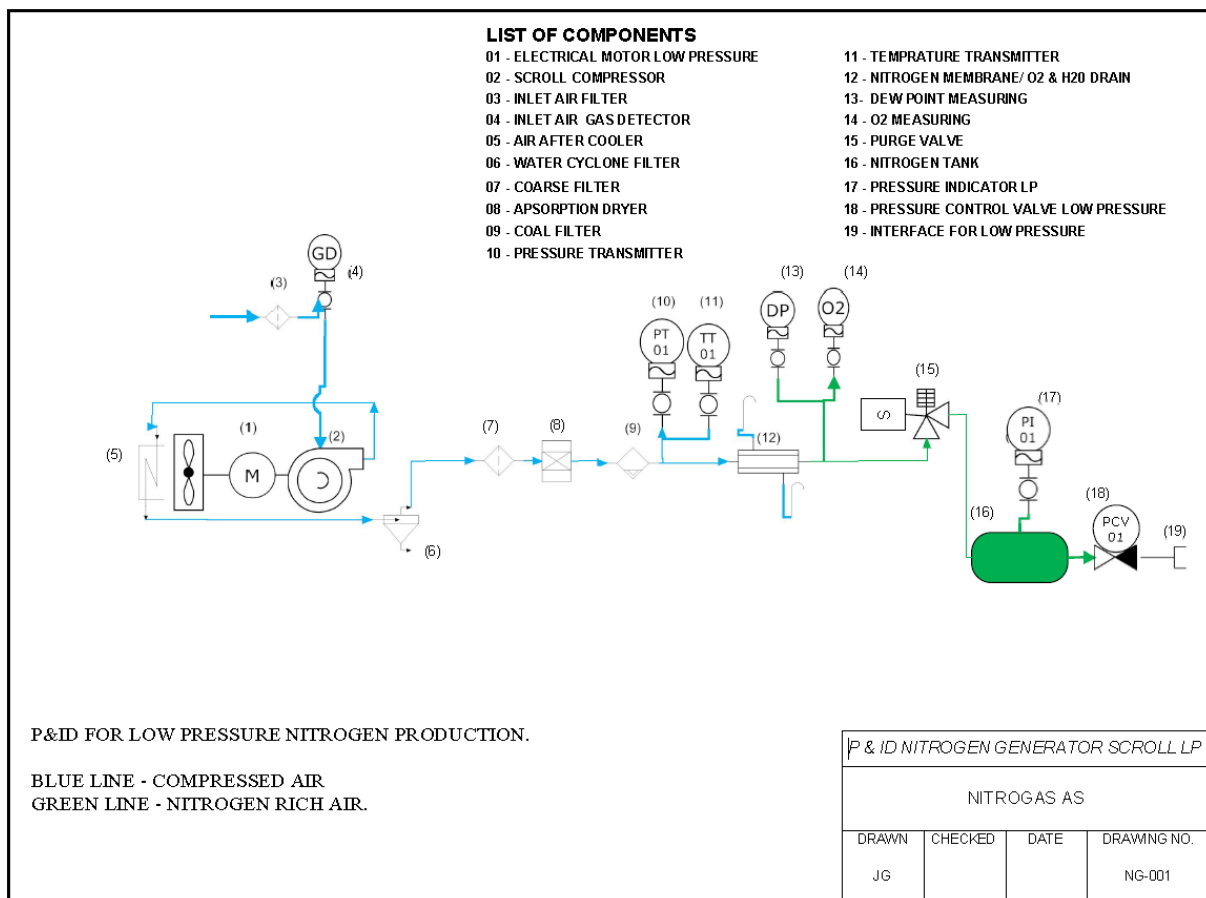

Figure 4.2 – P&ID of the Nitrogen generator based on scroll compressor.

The main difference on the Hitachi 5,5 KW scroll element and the old 3,7 KW scroll element from Compressor world, figure 4.3. And Hitachi 5,5 kw scroll element in figure 4,4 is the size and that inlet air connections.

Hitachi is overall bigger and has two inlet air connections, while Powerex compressor has one inlet air connection.

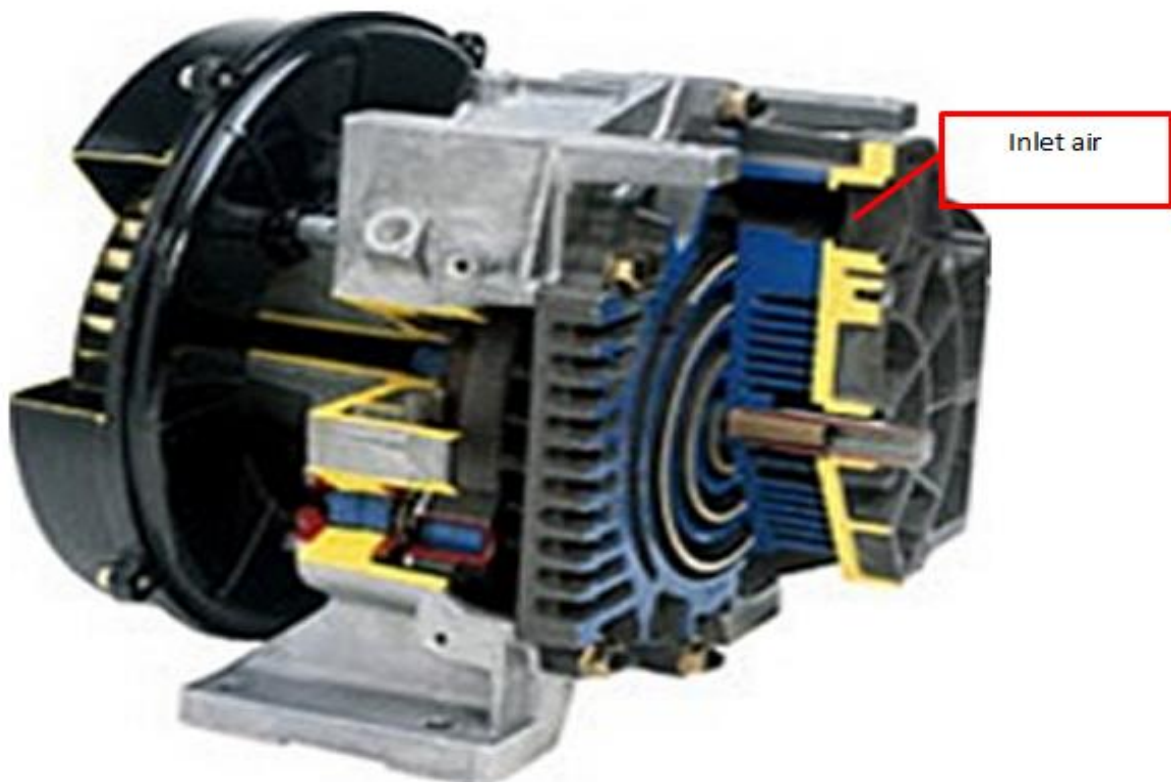

Figure 4.3 – Powerex 3,7 KW scroll element from Compressor World [14]

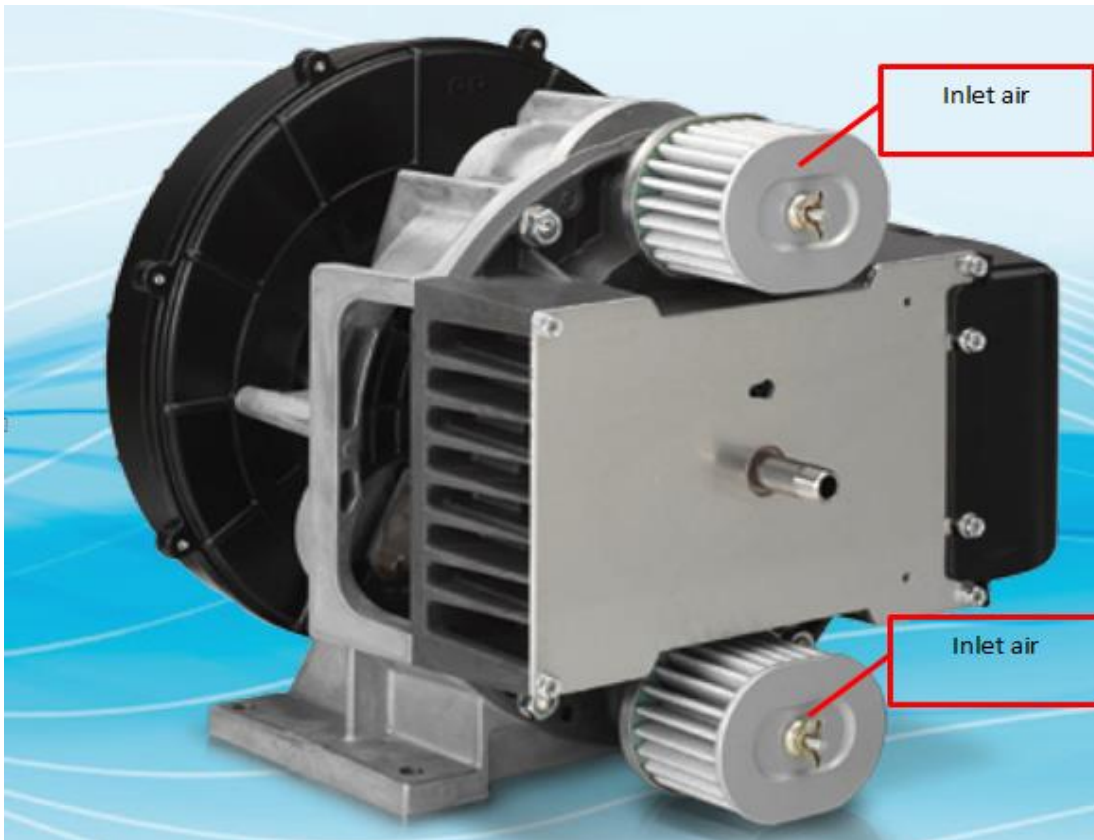

Figure 4.4 – Hitachi 5,5 KW scroll element . [Appendix 10]

New parts had to be constructed and solutions for fitting the new scroll compressor to the E compressor unit. Figure 4.5 is a drawing of the Hitachi scroll compressor fitted at new motor base plate and modified 1.st cooler solution. Appendix A.10 is a 2D drawing and data sheet.

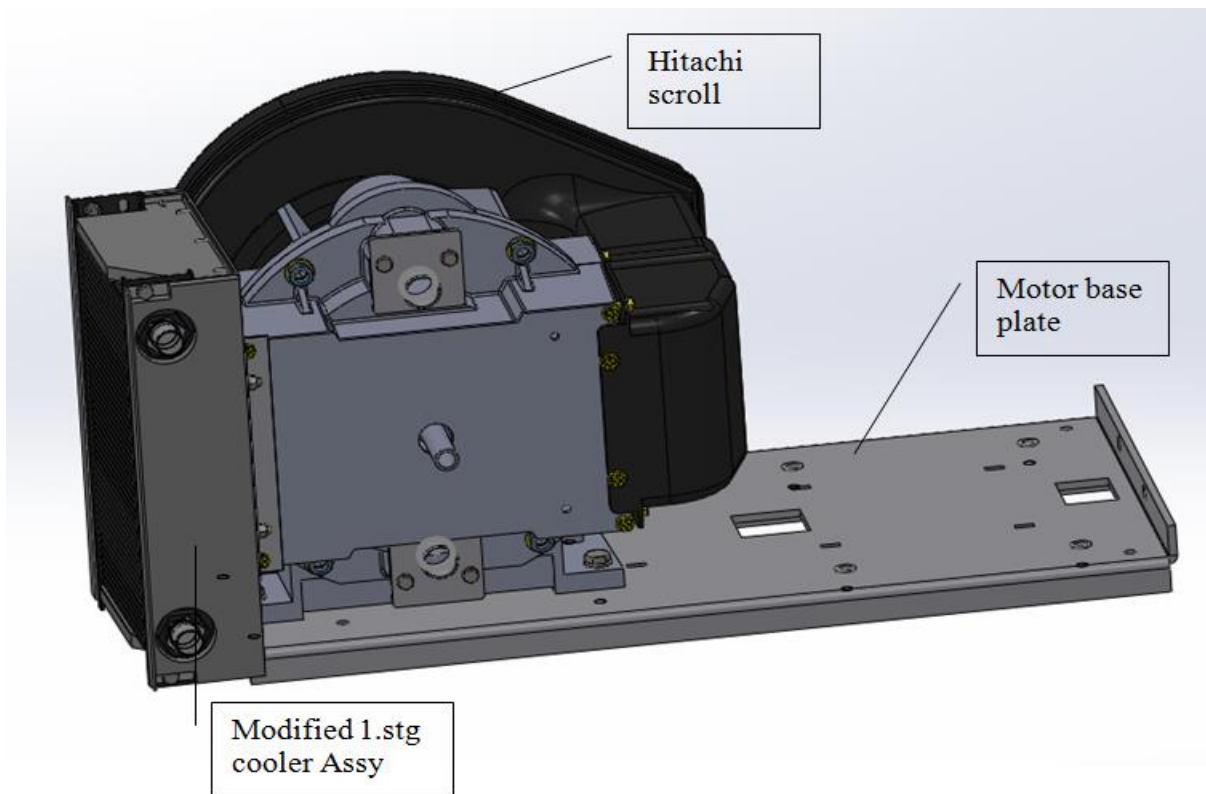

Figure 4.5 – Hitachi scroll compressor on motor base plate and 1.stg cooler.

New parts had to be designed and some modifications had to be done to get the Hitachi scroll installed in the E Compressor unit.

Appendix A.1 is an overview over new parts that were made for this application.

Modification and new components and parts were made for install the Hitachi scroll element inside the E Compressor, shown in figure 4.3. All components like air inlet (green hoses) , discharge air hoses (purple), coolers, electrical motor arrangement etc.

Test was carried out by E innovation and the Hitachi scroll element was delivering as designed 600 l/min@8 bar (g). But the air purification system on the E compressor makes is using approx. 150-200 l/min, resulted in an effective flow of 400-450 l/min into the membranes.

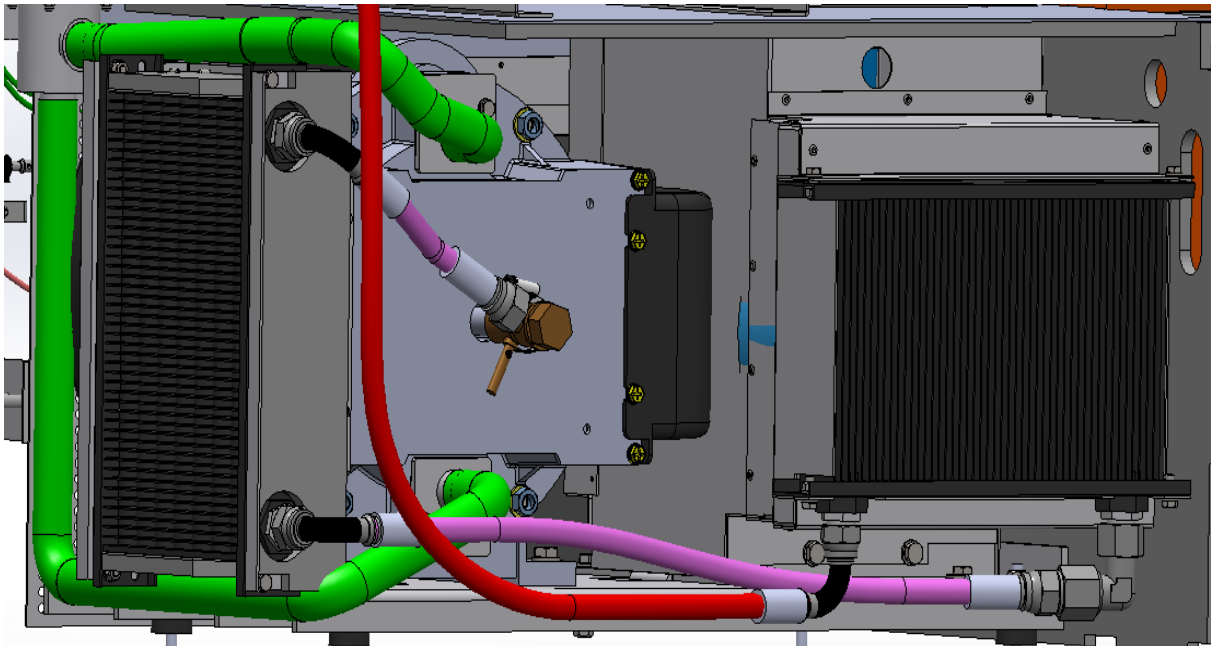

Figure 4.6 – Hitachi compressor mounted in the E compressor unit.

#### 4.1.2. Conclusion scroll compressor

Conclusion after test of scroll and specification on membrane from suppliers and datasheets from several membrane generators manufactures it was clear that the design specification on the rated nitrogen flow was not achievable with the Hitachi scroll element. This would give a nitrogen production of approx. 150 l/min.

Conclusion was drawn and scroll element had too little capacity. Hitachi will in 2014 introduce a new scroll with capacity of 800 l/min. This can be an option during developing on different mobile nitrogen generators.

Note; Hitachi 5,5 KW scroll have now been installed in 10 E compressors used on the UK oil sector.

#### 4.2. Alternative low pressure compressor

Due to the conclusion that the scroll element has too little capacity, other types of compressor elements had to be considered.

There are several types of air compressors that can be used.

- Piston compressor
- Scroll compressor
- Screw compressor
- Vane compressor



#### 4.2.1. Piston Air Compressors

Piston air compressor is typically used in applications that require small capacity, up to around 1000 l/min. Figure 4.7 shows the concept of a piston compressor.

Piston compressors are positive displacement compressors, same flow at different pressures.

This means that the air flow is not depending on the discharge pressure, the pressure can rise higher than design pressure if the piston compressor is running against “Dead Head” or closed discharge. So to prevent that the compressor is running over the design pressure and not get damage, the compressor has a safety valve on the discharge side, that open at maximum design pressure.

Normally the electrical motor will stop before this, due to a signal from a pressure indicator.

Good reliability and durability on this compressors.

Oil lubricated parts.



Figure 4.7 – Concept of a 4 piston compressor with V-block [8]

#### 4.2.2. Screw Compressors

Screw compressors are the most common on compressor system with large capacity, up to 100 m<sup>3</sup>/h. Oil are used to seal and lubricate between the screws, this means that there are lots of oil that have to be removed from the compressed air. Higher specifications to remove the oil content in the air than on the scroll and piston compressors.

But it is now also possible with water injected on the high capacity elements, from 5,0 m<sup>3</sup>/h , so it's not relevant for the Nitrogen generator at the moment.

Most of the screw compressors has many control options, so it can be designed for variable speed, no-load operations, mechanical regulating of flow. This means that the screw compressor can be very energy efficient.

Screw compressor is positive displacement, same as piston compressor, but since the screw compressor can have an internal regulator, the pressure can be adjusted according to the design of the system.

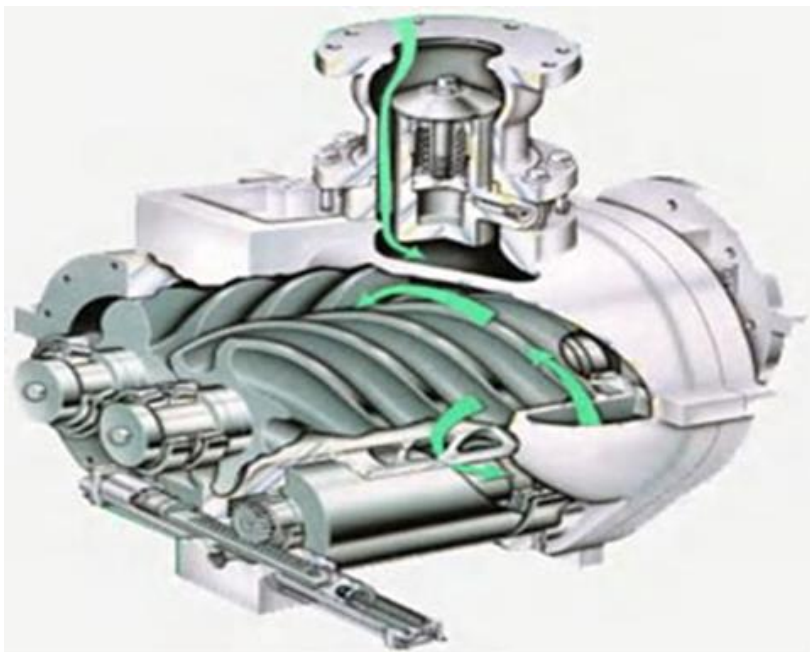

Figure 4.8 – Screw compressor design. [8]

### 4.2.3. Vane Compressors

Vane compressors are not so frequently used as the other compressors. But has a growing market. Capacity is up to around 15 m<sup>3</sup>/h, and 75KW, so this can be used high capacity systems.

Oil lubricated with internal oil separating, and internal regulating of the air flow. [15]

Figure 4.9 is showing the principle of a vane compressor.

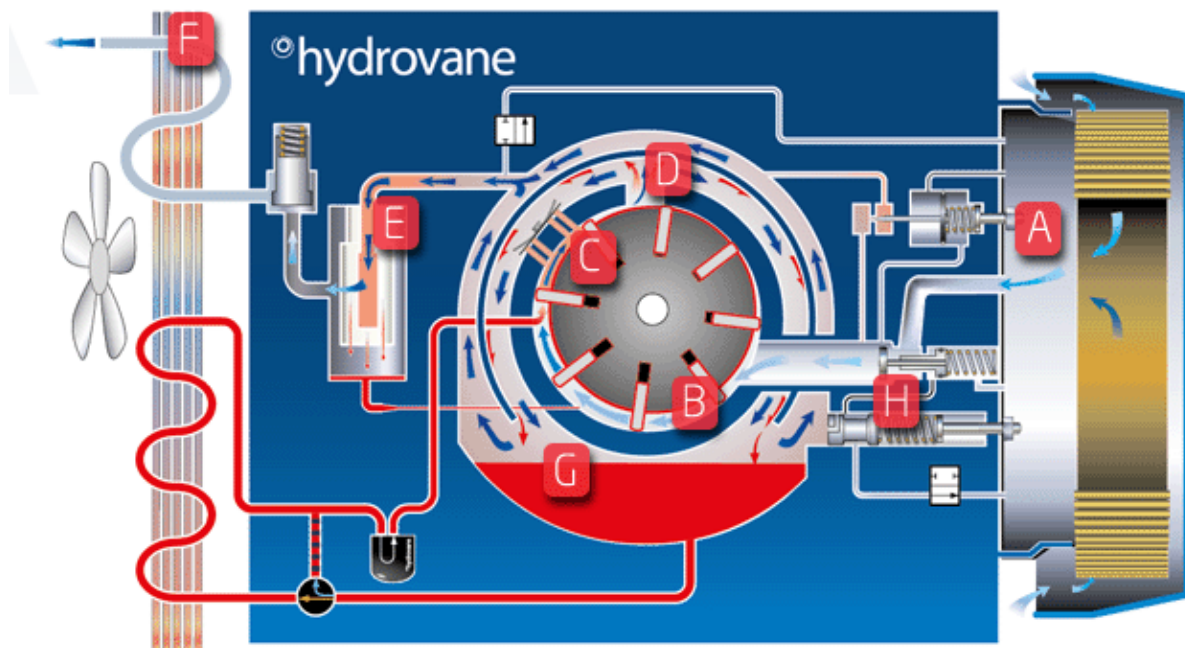

- A: Air is drawn in through the intake valve.
- B: Air is contained between the rotor and stator wall.
- C: Air is compressed by decreasing volume. Lubricant is continually injected to cool, seal and lubricate.
- D: High pressure air passes into the primary oil separator.
- E: Remaining traces of lubricant are removed in a final separator element, ensuring high quality air.
- F: System air passes through the aftercooler, removing most of the condensate.
- G: Lubricant is circulated by differential air pressure (No lubricant pump required). It passes through an air-blast lubricant cooler and filter before being returned to the compressor.
- H: Air flow is regulated by an in built modulation system.

Figure 4.9 – Illustration of the vane compressor concept. [15]

#### 4.2.4. Selection Low pressure compressor

For the Nitrogas nitrogen generator unit, the main focus for selection of a compressor type is that it's compact, good capacity according to size and easy to install.

Air capacity/flow from the compressor is according to FAD (Free Air Delivery). FAD is the actual quantity of compressed air at the discharge of the compressor. The units for FAD are CFM in the imperial system and l/min in the SI system. The units are measured according the ambient inlet standard conditions ISO 1217 - 1 bar (abs) and 20°C.

#### Note:

One important parameter that are different from the scroll compressor and the rest of the oil lubricated compressors, Is that since there is no oil content in the air from the scroll, there is more “free” Ozen in the air from the scroll, The ozen at the oil lubricated compressor are being “capture” and mixed with the oil.

Ozen in the air has to be roved, this result that the purification unit for the air has to be almost the same as for the other oil lubricated compressor. Nitrogen membrane has a small tolerance on the ozen content in the air, because the polymer fibers in the membrane will get damaged by the ozen.

#### Pros and Cons for the different types of LP compressor for the Nitrogas application.

Scope	Piston	Scroll	Screw	Vane
Size	1	3	5	3
Capacity	1	3	5	3
Noise	2	3	4	4
Heat generating	4	2	4	4
Availability	5	3	4	3
Reliability	5	3	4	3
Durability	4	3	5	4
Air quality	3	5	3	4
<b>Total Score</b>	<b>25</b>	<b>25</b>	<b>34</b>	<b>28</b>

Table 4.1 – Table of Pro & cons for selection of compressor type.

Out from the study and the design criteria in chapter 3.0 a screw compressor element is the best solution for the Nitrogas nitrogen Generator.

Screw compressor for the prototype is from Fini compressors in Italia, they have several compressor elements that were offered. And there was not a problem to only buy compressor block and main components.

Fini has a nice compressor solution on the FSC 50-11 KW, where the electrical motor is connected directly on the screw compressor. Figure 4.10 is a 3D model of this solution.

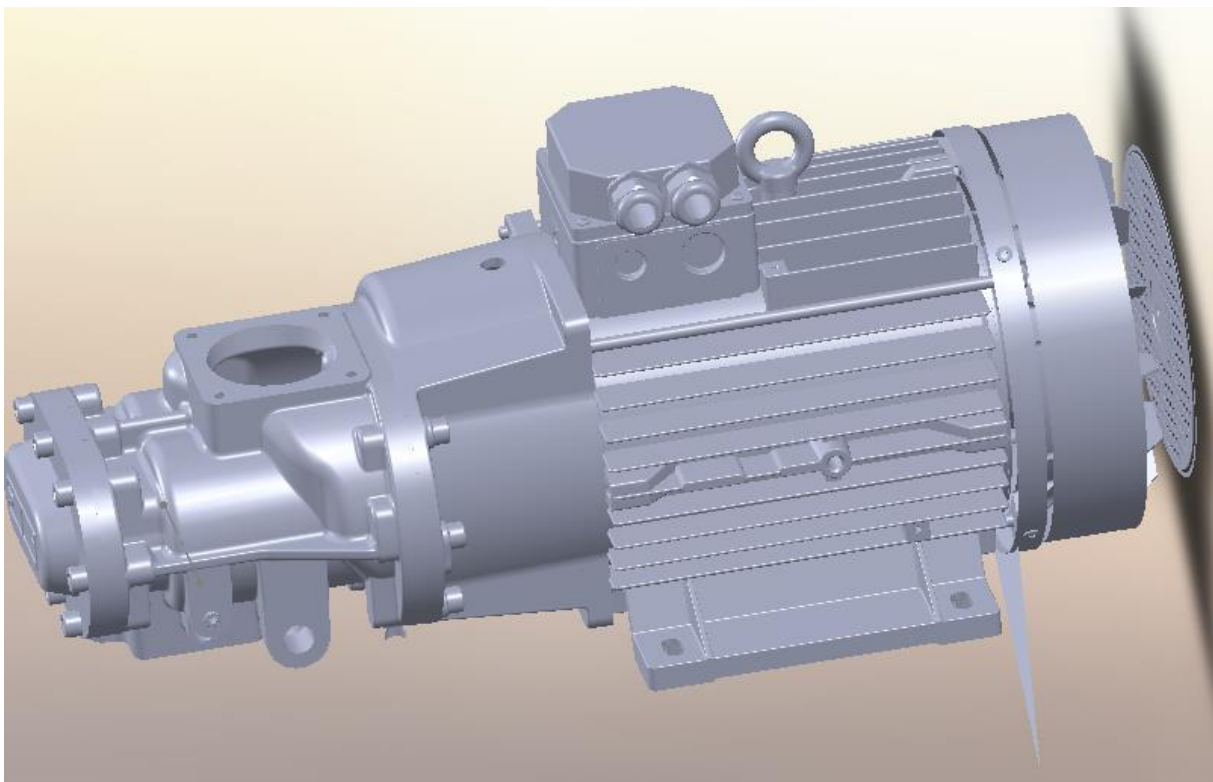

Figure 4.10 - 3D model of the Fini FSC 50 11KW

Fini Compressors screw element FS 26 TF5,5 – 15 KW and FSC 50-11KW screw compressors will be good alternatives. See Appendix A.2.

For the Nitrogas Nitrogen generator prototype, the FSC 50-11KW has been ordered.

FSC 50 has an capacity at 1750 l/min @ 8 bar(g). FAD.

$$Efficiency = \frac{600 \text{ l/min}}{5,5 \text{ KW}} * 60 \text{ min} = 9545 \frac{\text{l}}{\text{kwh}} @ 8\text{bar}(g)$$

References from chapter 4.1.1, the screw compressor has a better efficiency then scroll compressor on the air capacity per kwh.

#### 4.2.5. LP compressor electrical motor

Fini is delivering the compressor with an integrated 11 KW electrical motor. This will work as a test motor on the prototype.

After a test of the prototype, decisions regarding motor alternative, speed regulating etc. Since Nitrogas nitrogen generator will be designed for Atex zone 1, new motor has to be according to these specifications.

#### 4.3.High pressure and low pressure generator

Due to information and request from IKM , the design criteria for discharge pressure was set to 40-70 bar (g), because IKM need 40-70 bar (g) inlet pressure for an air driven booster, figure 4.10. IKM use this for high pressure testing with nitrogen, boost pressure up to 980 bar.

GAS BOOSTER			
			
Dimensjon	:	L 540 mm	B 770 mm H 650 mm
Vekt	:	90 kg	
Lofting/Transport	:	Fraktes på palle.	
Type	:	Hydratron type GB118D	Ser. nr.
P maks.	:	980 bar	
Q maks.	:	73,7 cm <sup>3</sup> pr syklus (2 slag)	
Q eksempel:	:	Trykk tilført	Mottrykk i system Flow
	:	70 Bar	410 Bar 259 N l/min
	:	140 Bar	410 Bar 587 N l/min
Tilkopling gass inn	:	1 stk. 1/4" BSP Male	
Tilkopling gass ut	:	1 stk. 1/4" BSP Male	
Tilkopling luft	:	1 stk. 1" Offshore klokopling	
Filter gass inn	:	Vaskbar strainer.	
Andre opplysninger	:	Må ha minimum 40 bar gass inn. Stasjonert hos IKM Laboratorium AS.	
Bygge år	:	1998	

Figure 4.11 – Air driven high pressure booster that IKM use.

Production of nitrogen is done with air pressure at 5-14 bar (g), this means that if discharge pressure at 40-70 bar nitrogen from the Nitrogas generator, an additional compressor has to be installed to the unit.

Research of additional high pressure compressor resulted in that it was possible to get compressors for 100 bar discharge, but the size was almost the same as a high pressure compressor with 300-350 bar discharge pressure.

This means that to make the nitrogen generator as convenient as possible, it will be designed with one low pressure compressor and high pressure compressor.

Low pressure compressor has to have at least 3 times the flow capacity as high pressure compressor, due to the use of air during production of nitrogen.

Low pressure compressor will supply air for nitrogen production and deliver nitrogen at 2-8 bar (g). Electric driven high pressure compressor/booster will be able to pressurize nitrogen to 300-350 bar (g). Figure 4.12 is illustrating the P&ID for this solution, where the HP compression is marked with red circle.

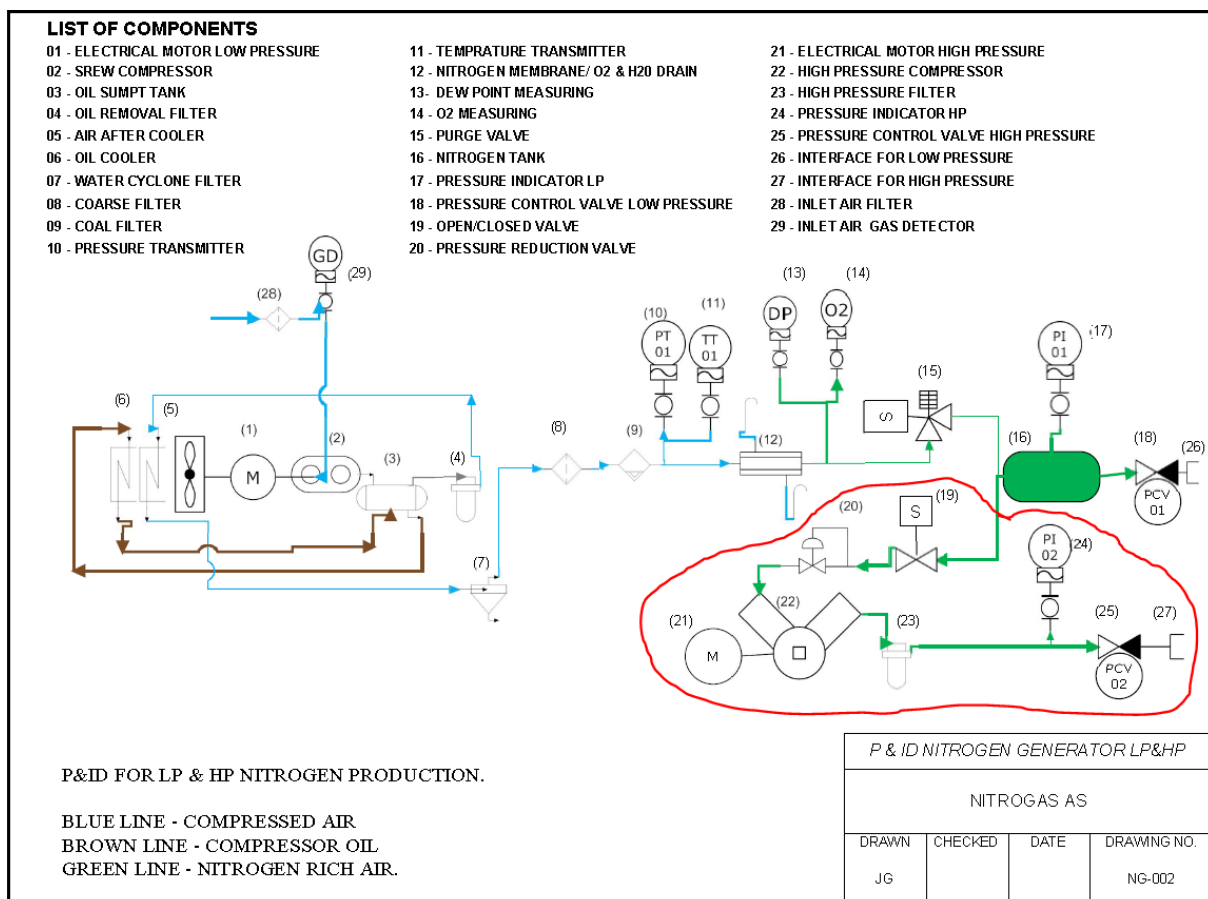

Figure 4.12 – P&ID for low and high pressure nitrogen generator.

Combined nitrogen generator with integrated post compressor that can give a discharge pressure of 300 bar (g), will give a much wider user applications.

When integrating an HP compressor unit to the nitrogen gen generator unit, there will be a good option to install a small 6 liter HP bottle (300 bar) as an accumulator on the discharge line of the HP compressor.

6 liter @ 300 bar, will give an buffer time of approx. 4 minutes from 300 bar to 100 bar.

This will help the HP compressor for a more smother operation. As indicated in figure 4.13.

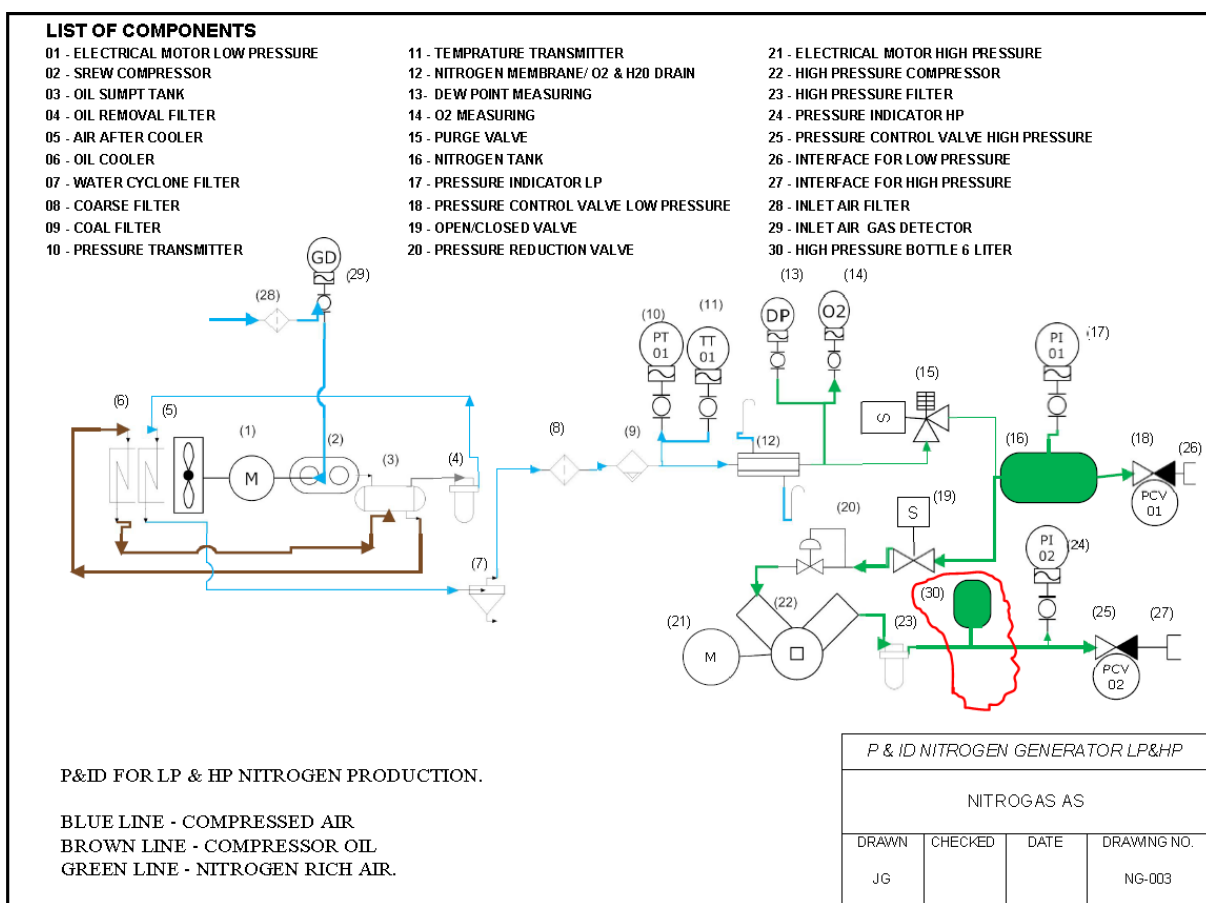

Figure 4.13 – Integrated 6 liter HP bottle.



#### 4.3.1. Selection of high pressure Compressor

For compression of nitrogen up to 300 bar (g), there is only piston compressor that are convenient to use.

High pressure piston compressor/booster can be driven by:

- Electrical motor
- Engine motor
- Hydraulic motor
- Air driven

Two of this was considered for the nitrogen generator.

#### **Air driven booster pump:**

Air driven booster pumps has been on the marked for long time, it's well proven technology. Since the pump is driven by air it is ideal for hazardous areas like Atex zone 1.

#### **Advantages:**

- Oil Free
- No electrical use
- Ideal for Atex zone 1
- High pressure up to 1000 bar (g)

#### **Disadvantages for this configuration are:**

- Need for external compressed air.
- Limited capacity
- Big in size.

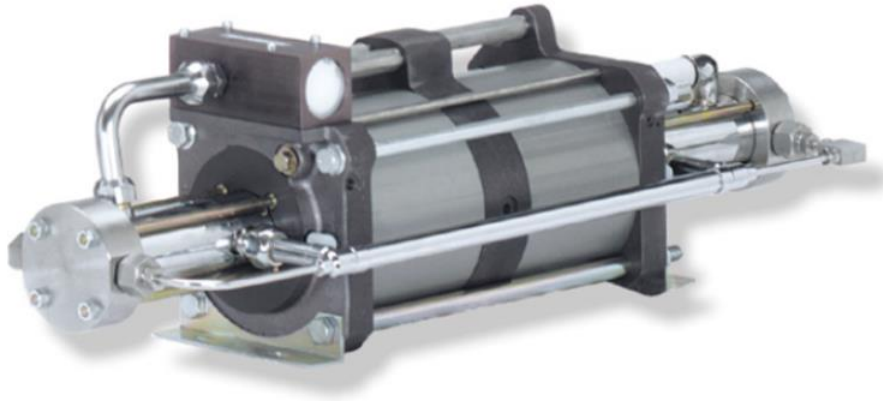

Figure 4.14 – Picture of an air driven HP booster. [16]

### Electrical driven HP piston compressor.

Electrical HP piston compressor have been on the market for long time, and there are several manufactures. These compressors are piston compressor with normally a W-block configuration, with normally 3-4 stage compression. Figure 4.14 is an illustration of a Bauer compressor block.

### IK100/120 Air Compressor

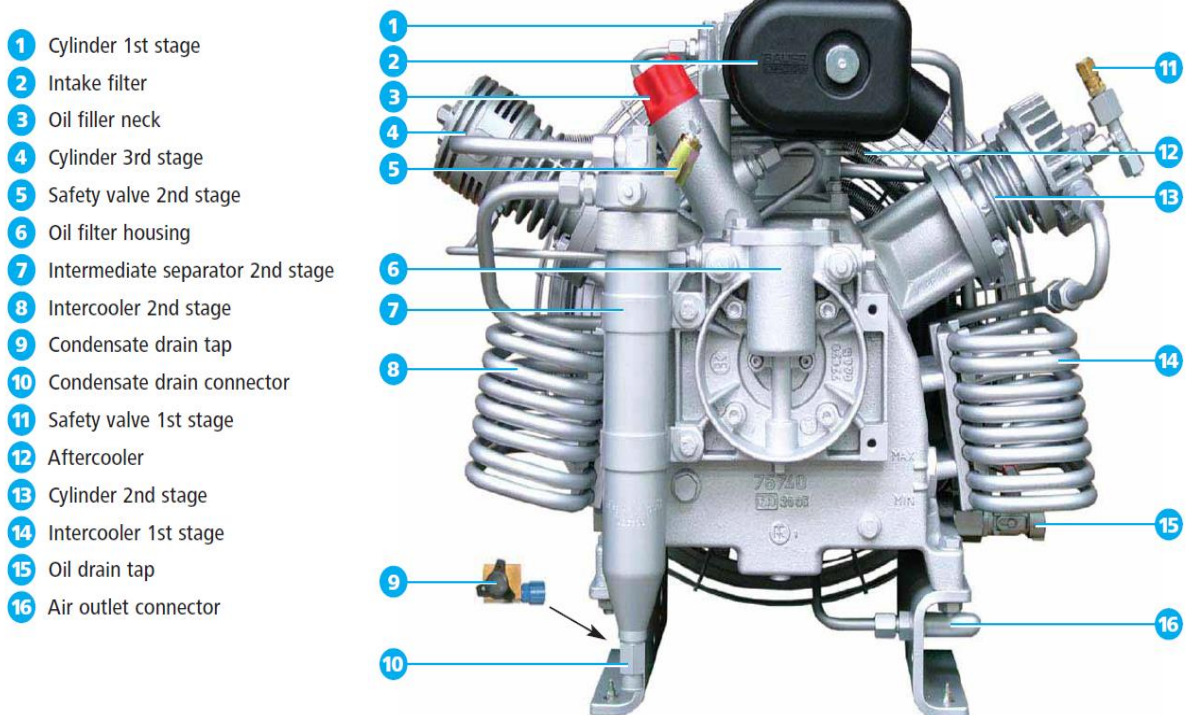

Figure 4.15 – Bauer IK100/120 HP air compressor block. [17].

Advantages:

- Electrical
- Noise
- Capacity

Disadvantages for this configuration are:

- Have to do an Atex certification
- Oil lubricated
- Filtration of nitrogen.

There are many manufactures of high pressure piston compressors

- Nardi
- Bauer
- Hertz
- Rewell
- Maximator
- Comp Air

All of this can deliver high pressure compressor systems, but only Bauer have a high pressure booster that can operate with inlet air pressure at 5-11 bar(g). Bauer MV- GIB series has an booster compressor block that can take inlet pressure from 5-11 bar (g) and flow from 200-475 l/min [17].

There is one problem with this compressor block from Bauer that is that it is not possible to buy it from Bauer. So this means that some other suppliers have to be considered. If this booster had been an option, the pressure reduction regulator position 20 in figure 4.16 could have been removed. Result in a little more simplified version of the system and more efficiency. Since you don't need to take the pressure up again from 0, 5 bar, but continue from LP compressors discharge pressure.

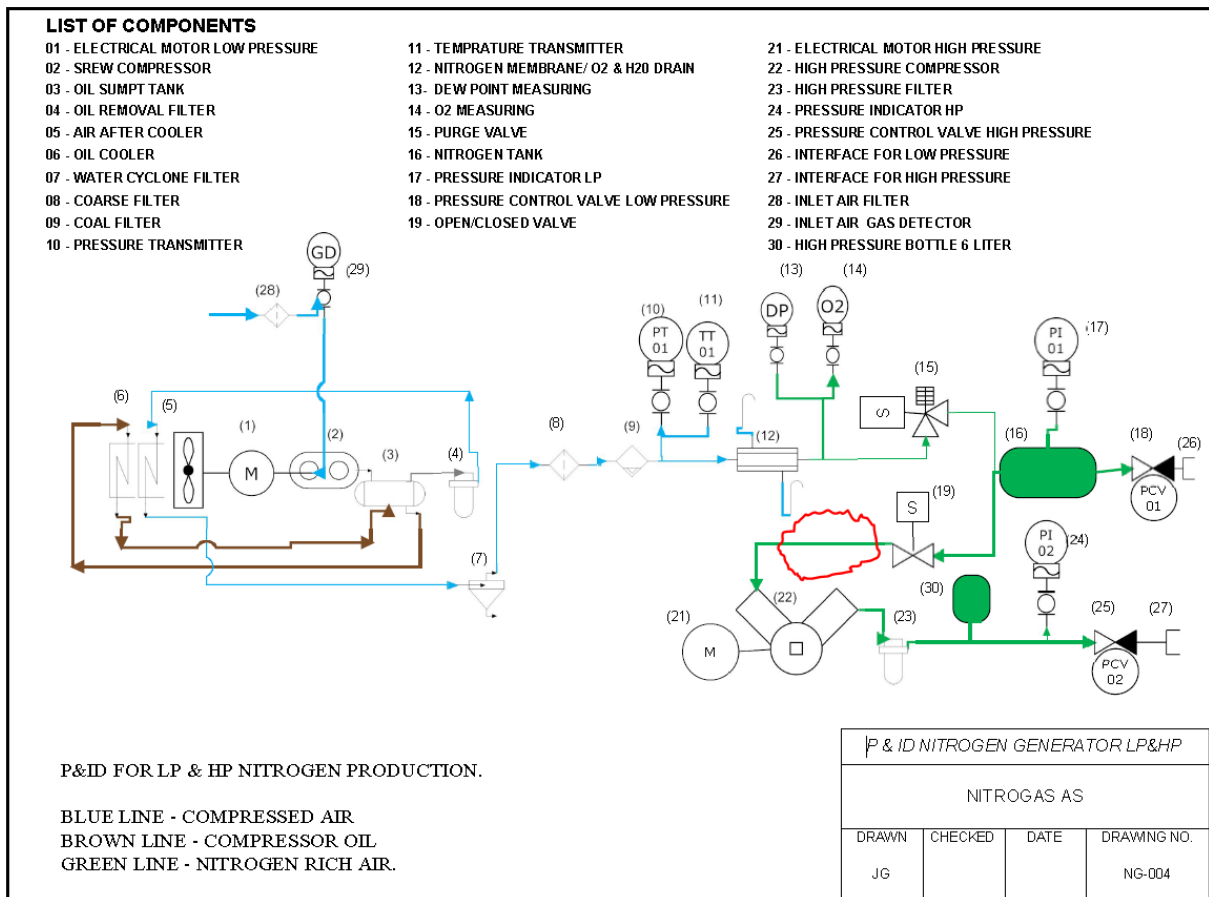

Figure 4.16 – P&ID of the HP system with a Bauer booster compressor.

The selection was an compressor block from Nardi compressors, that are an normal HP block that need an inlet pressure of maximum 0,5 bar.

The compressor block is from a breathing air HP bottle generator, Pacific E series, giving a pressure up to 300 bar (g) and flow of 300 l/min. [18]. See appendix A.3.

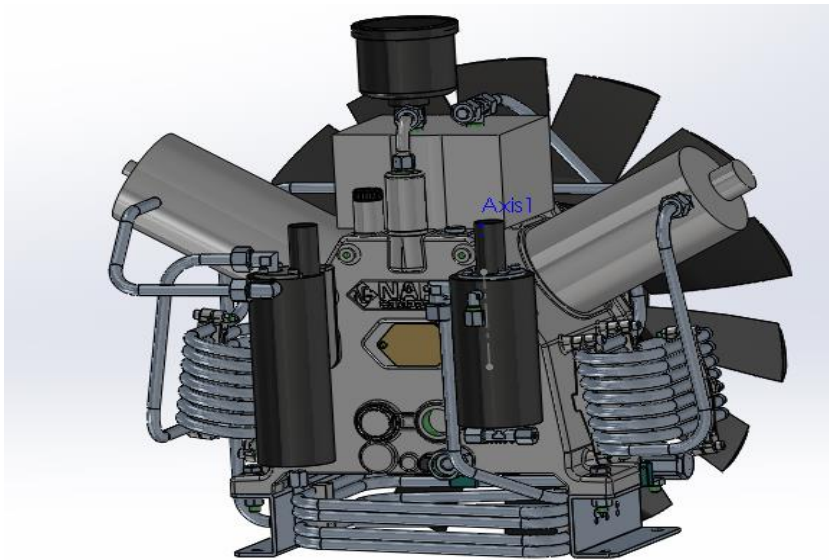

Figure 4.17 – 3D model of Pacific 300 compressor block from Nardi.[18]

### **Conclusion for selection of HP compressor:**

Since the Nitrogas nitrogen generator is based on electrical driven components. An electrical HP compressor is the best alternative. The philosophy of Nitrogas mobile generator is that you only need to plug it to an electrical line.

If an air driven booster had been used, you also need an air supply to unit. This will not fulfill the design criteria that were settled.

Future work on the HP compressor is to get a designed HP booster that can take an inlet pressure of 6-8 bar, so it will not be necessary to waste energy to take the pressure up again from 0,5 bar, but continue from LP compressors discharge pressure.

#### **4.3.2. HP compressor electrical motor**

HP compressor from Nardi requires a 5,5KW motor for the operation. E Innovation is using an 5,5 KW motor from Rael that are Atex certified. For testing of the prototype, a motor from E innovation is supplied.

#### **4.3.3. HP filter**

Parker that is supplying the membrane and the filter systems for the air purification system has recommended that an HP filter from Parker.

Parker G03/350-G07/350 is inside our specifications regarding pressure and flow and will be delivered by Hillevåg Elektro Diesel.

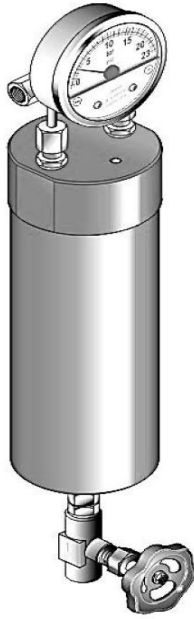

Figure 4.18 – HP filter form Parker.

#### 4.3.4. Features on HP nitrogen generator

Designing and configuration of many components that has to be integrated into one complied and well function system is giving some opportunities to think “outside the box”. So this configuration in figure 4.19 is showing that when configuration is that can HP booster compressor and LP compressor can be integrated together with the same electrical motor.

This means that LP compressor and HP booster has to be tuned together.

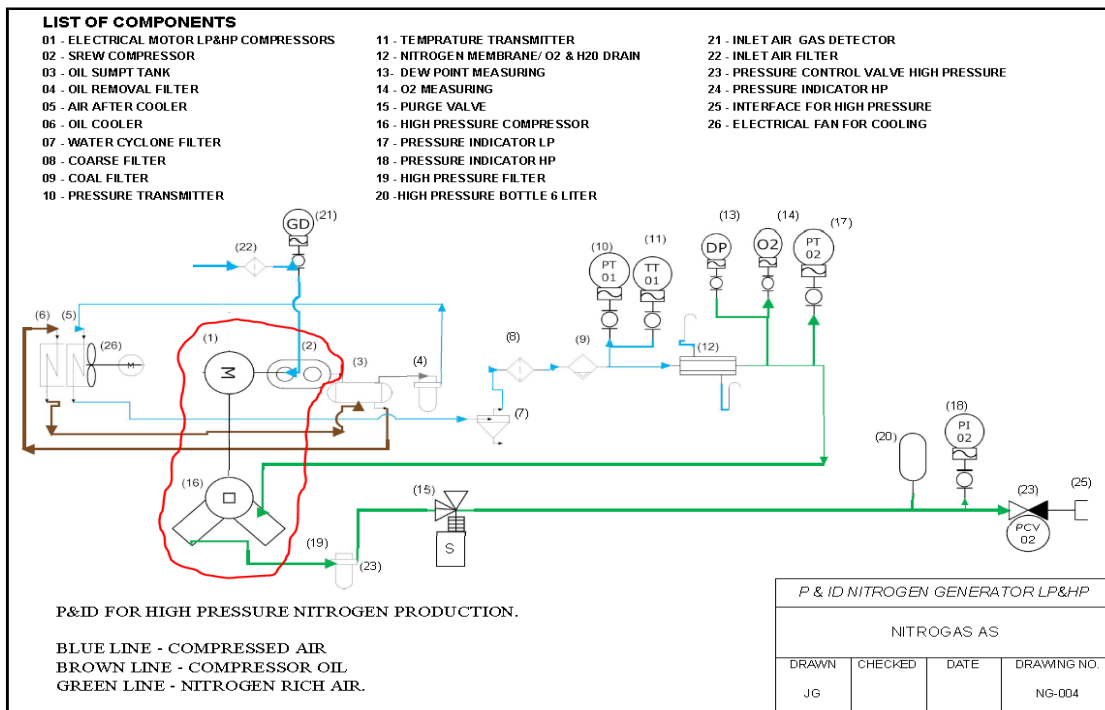

Figure 4.19 – P&ID for integrated LP an HP on common electrical motor.

#### 4.4. Nitrogen Membrane

There are 3 main suppliers of Nitrogen Membranes that we can use for this application.

- PARKER
- GENERON® IGS
- INMATEC.

##### **PARKER**

Parker is a big Global company that is supplying lots of components and equipment to the global Industry. Parker has stationary Nitrogen Membrane Generator that is designed for operations in non-classified areas. [10]

##### **INMATEC**

Inmatec is a German based company that is making Nitrogen and Oxygen generators for the global industry and oil and gas industry, also Atex classified. But they only make the membrane unit, without air supply. [19]

##### **IGS**

**Nitrogen Membrane Generators** - The Nitrogen Generators utilize the Genron IGS membranes produced in the Company's own manufacturing facility in Pittsburg, California. Systems supplied with the Company's Membranes are assured the highest operating efficiency on the market. [7]

All three companies were contacted, but only Parker was willing to sell separate nitrogen membranes for this project. Hillevåg Elektro Diesel was an OEM for Parker here in Stavanger.

#### 4.4.1. Parker ST708 Nitrogen Membrane

Parker came up with a new Nitrogen membrane that was ideal for our project. This was based on Parkers own Hifluxx N2 membranes, but more compact. See appendix A.4.

Model ST708 is designed to operate from 5-12 bar (g), but Parker recommended to use 6-8 bar feed pressure of the air.

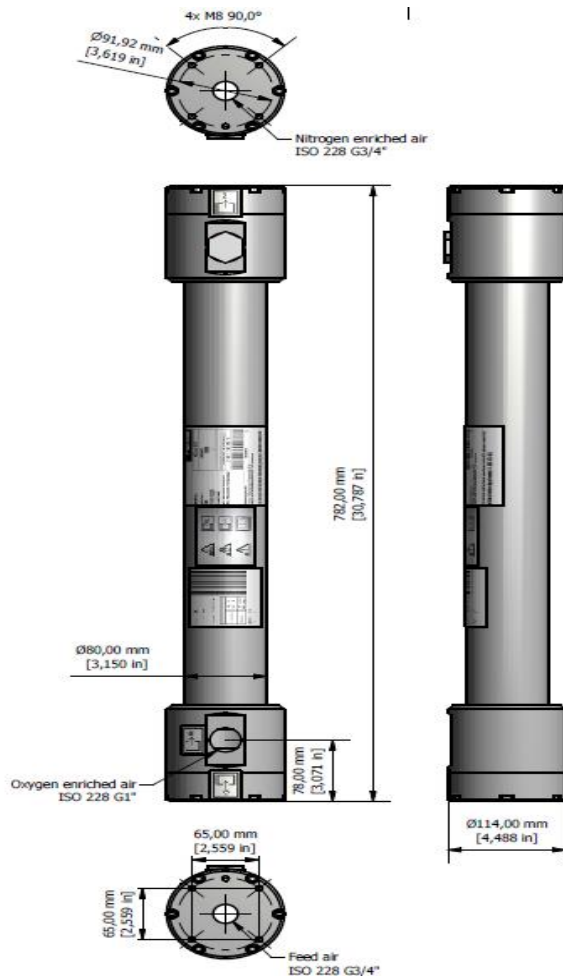

Figure 4.20 – Parker ST708 nitrogen membrane [10]

According to Parker, this will give us an ANR (air Nitrogen Ratio) 2,5

$$ANR = \frac{\text{Inlet air flow}}{\text{Outlet nitrogen flow}} = 2,50$$

Designed and recommended inlet flow on one ST708 that we will use is 500 l/min.

$$\text{Outlet nitrogen flow} = \frac{\text{Inlet air flow}}{ANR} = \frac{500}{2,5} = 200 \text{ l/min}$$



### Correction factor for Nitrogen capacity:

Inlet pressure Bar (g)	6	7	8	9	10	11	12
Correction factor	1	1,1	1,2	1,4	1,6	1,9	2,1

Table 4.2 – Correction factor on the nitrogen capacity

Parker is recommending to use 6-8 bar (g) inlet pressure on the membrane, this means that if we adjust the pressure to 8 bar, the nitrogen flow will increase to 1,2 of the design.

$$\text{Outlet N2 flow @ 8 barg} = \frac{\text{Inlet air flow}}{\text{ANR}} * \text{cor. factor} = \frac{500}{2,5} * 1,2 = \mathbf{240 \text{ l/min}}$$

$$\text{Inlet air flow} = \text{outlet N2} * \text{ANR} = 240 \frac{\text{l}}{\text{min}} * 2,5 = \mathbf{600 \text{ l/min}}$$

There is a correction factor for the inlet temperature also, but it is minor difference from design temperature at 20°C up to 40°C. Parker indicates a correction factor of 1, 1 at 40°C.

The inlet air temperature is also variation of the ambient temperature, so I decide not to use this correction factor, due to the different ambient temperatures that the generator can operate in.

According to the information from Parker regarding correction factor, we can calculate 240 l/min N2 from each membrane unit and compressed air consumption of 600 l/min.

We need also to consider leak of air from the compressor trough filtration and water removal. CCF (Compressor Correction Factor) of Air request x 1,25. [20]

As mention in chapter 4.2.4 Fini FSC 50-11KW scroll element has been ordered, this will give a flow at 1750 l/min @ 8 bar (g). **CCF of 1,25** is than giving an available inlet flow of **1400 l/min @ 8 bar (g)**.

#### 4.4.2. Conclusion of Parker Membrane

Considered all parameters, calculated N<sub>2</sub> flow is than calculated to a design of 2 pcs of Parker ST708 membranes a 240 l/min.

$$\text{Outlet nitrogen flow} = \frac{\text{Inlet air flow}}{\text{ANR}} = \frac{1400}{2,5} = \mathbf{560 \text{ l/min}}$$

This is inside the design criteria that is settle in chapter 3.0. We can consider that the nitrogen production from this design will be 500-600 L/min at 8 bar (g) and 95% purity.

#### 4.5. Air purification system

Parker and Hillevåg Elektro Diesel that are supplying the Nitrogen membrane made recommendation for filters and water removal components that can be used for air purification and to keep the air according to specification for the membrane. ISO8573-1:2010 class 1-4-1, the international standard of compressed air quality. See appendix A.5.

- 1 pcs Water separator, 1" : WS020EBFX
- 1 pcs Coarse filter, 1", 1µm : AO025EBFX
- 2 pcs Combination filters 1" 0,01 µm and Active coal filter : AC025EBFI

#### 4.6. Discussion for system design and components

Calculations and configuration of components has been done according to recommendations, manufactures information and specifications. Different components have to be configured together and tested as a system according to P&ID NG-004 in figure 41.16. Building and testing with the prototype will give the best indications of the design and the configuration between the main components.

## 5. Frame.

Frame for the Nitrogas nitrogen generator is planned to be constructed using Alloy steel 6082 – T6. This is a light but strong alloy with a yield strength of 310 MPa. Due the fact that the Nitrogas unit is designed for operation in Atex zone 1, use of material like Alloy is necessary due to non-sparking material in case of collision impact.

Design criteria for the Frame size is that it has to be portable, fitted with wheels, possible for lifting and max wide of 800mm.

Specifications on the designed frame

- Lifting weight of 400 KG
- Made ready for wheels
- Width of 800mm
- Length 1300 mm
- Height of 950mm without wheels.

### 5.1.Frame construction

Main components in the frame are designed with a standard 30mm alloy square tube. Shown in figure 5.1 and figure 5.2. These components are making the fundament for the components and the strength on the frame. Appendix A.11 is sheet from supplier of this pipe.

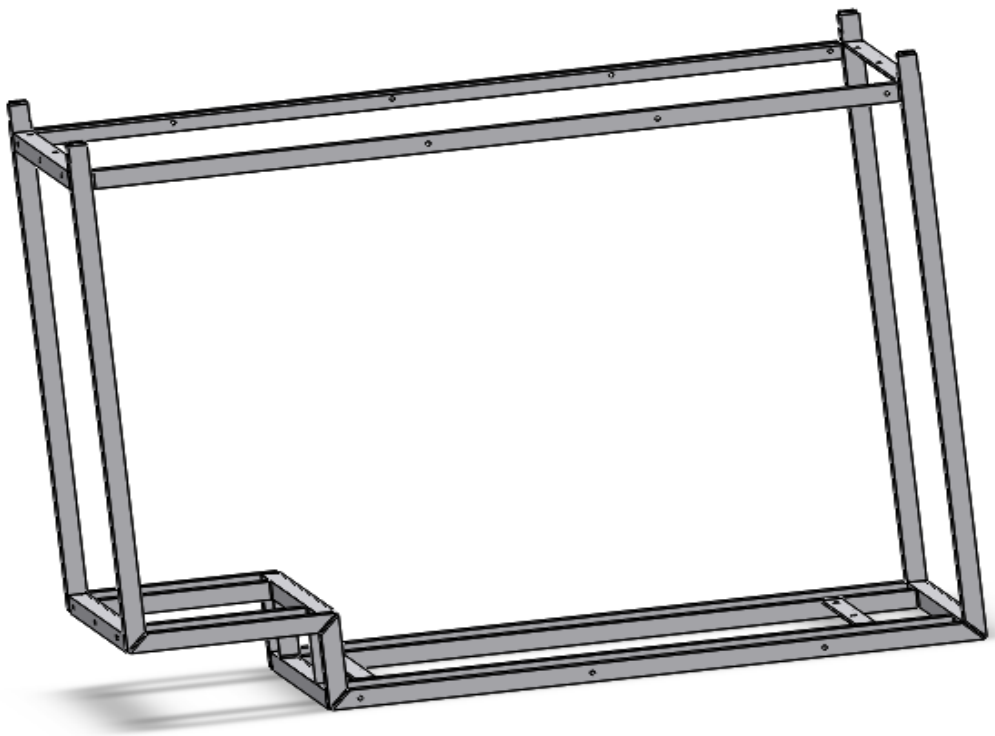

Figure 5.1 – Main Components of the structure of the frame.

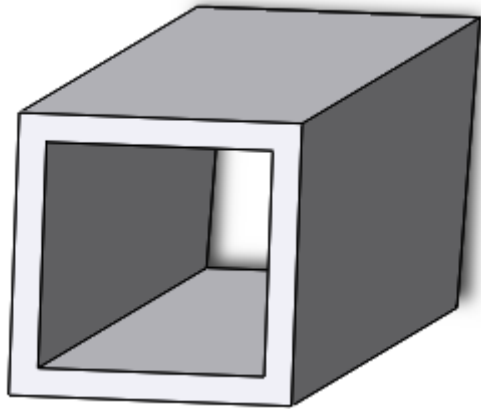

Figure 5.2 – Section of a frame structure beam.

The main structure on the frame is not design for applying all the components and the weight of the total unit during transport and lifting. The frame has to be design for integrating the components and for optimizing the design for lifting and weight.

Different beams and reinforcement plates was designed and pad eye constructed for lifting operation. Padeye design and calculation is a critical part for the lifting operation and has to be according to relatives standards. Chapter 5.1 is handling the design and calculations for the lifting arrangement. Figure 5.4 is showing the design of the padeye.

Frame has been reinforced for handling lifting operations and portable but is not completely done for integrating the main components.

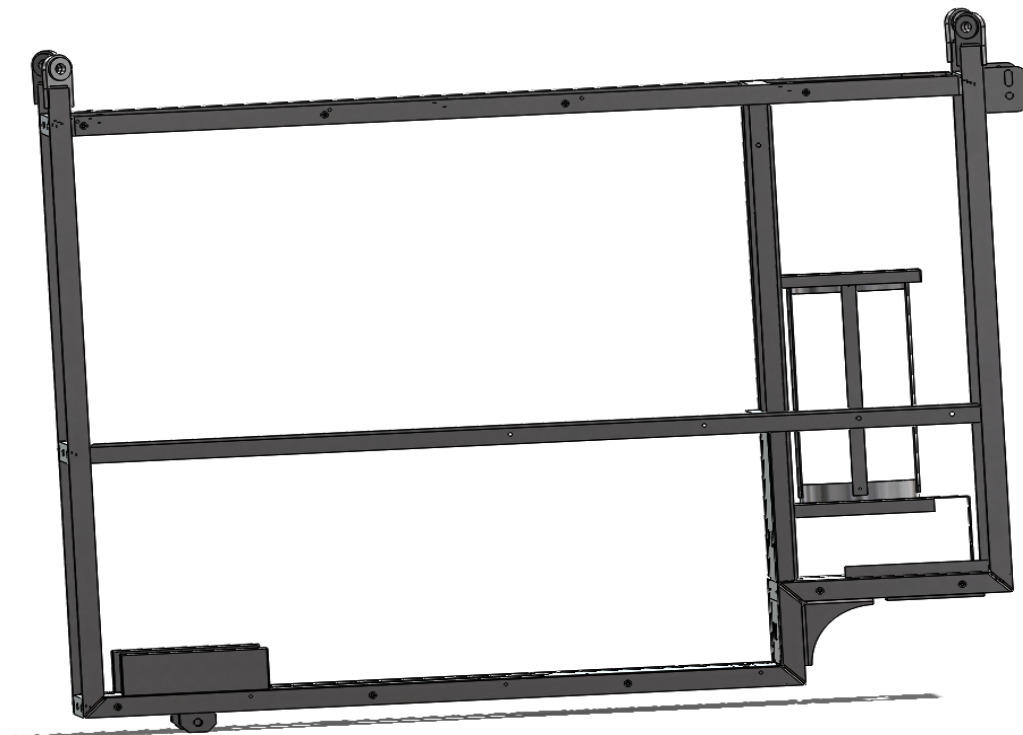

Figure 5.3 - Primary structure for the Nitrogen unit.

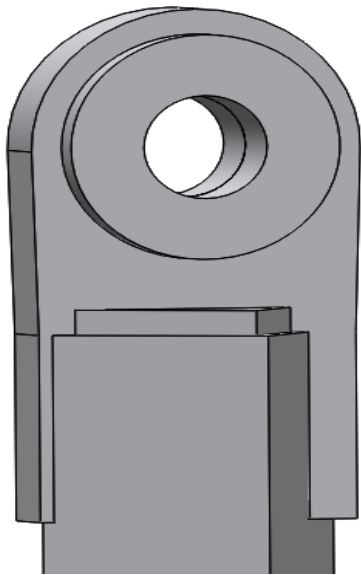

Figure 5.4 – Lifting padeye design for the frame.

Future work on the frame will be to continue the work to integrate components to the frame and solutions around this. Figure 5.5 & 5.6 is showing the main components inside the frame. This is done for getting an good overview of the size on each components and the opportunity to fit all components inside the frame design.

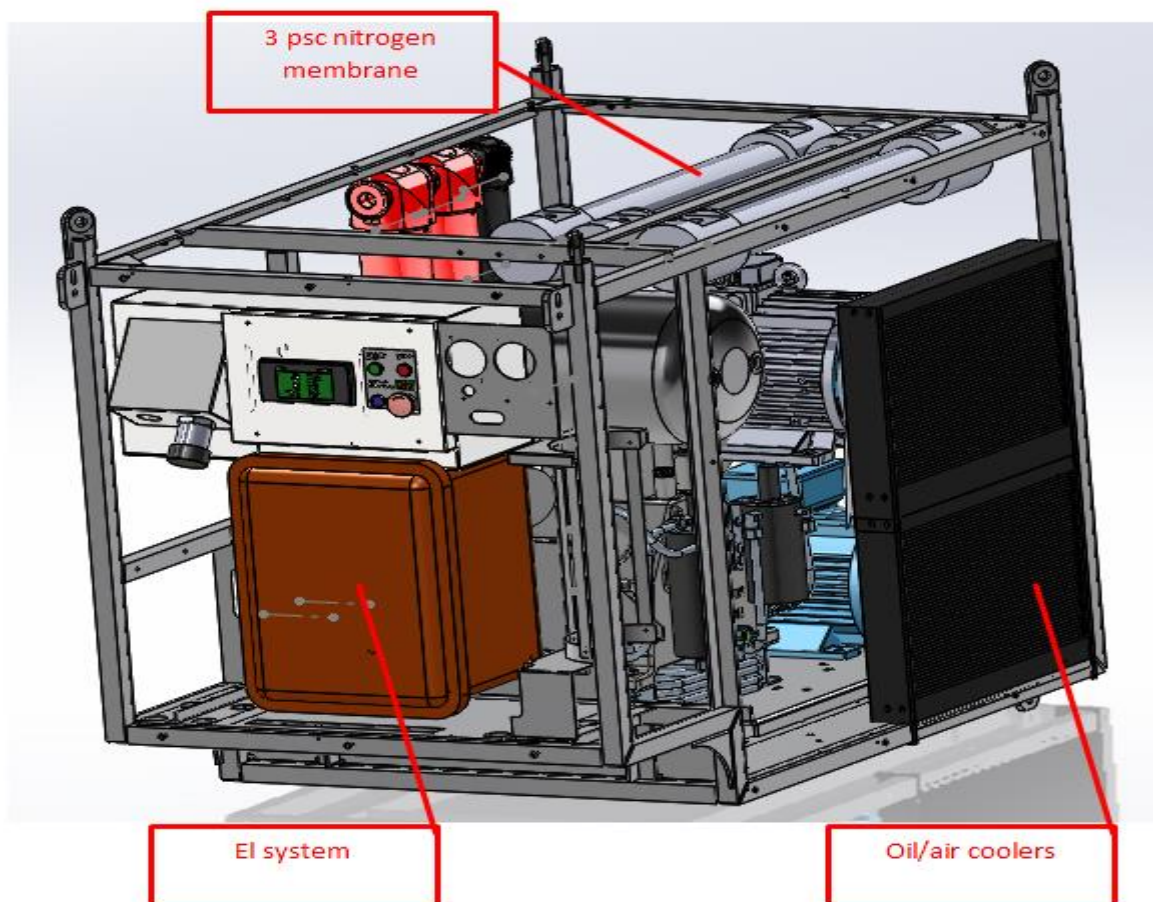

Figure 5.5 – Main components integrated into the frame.

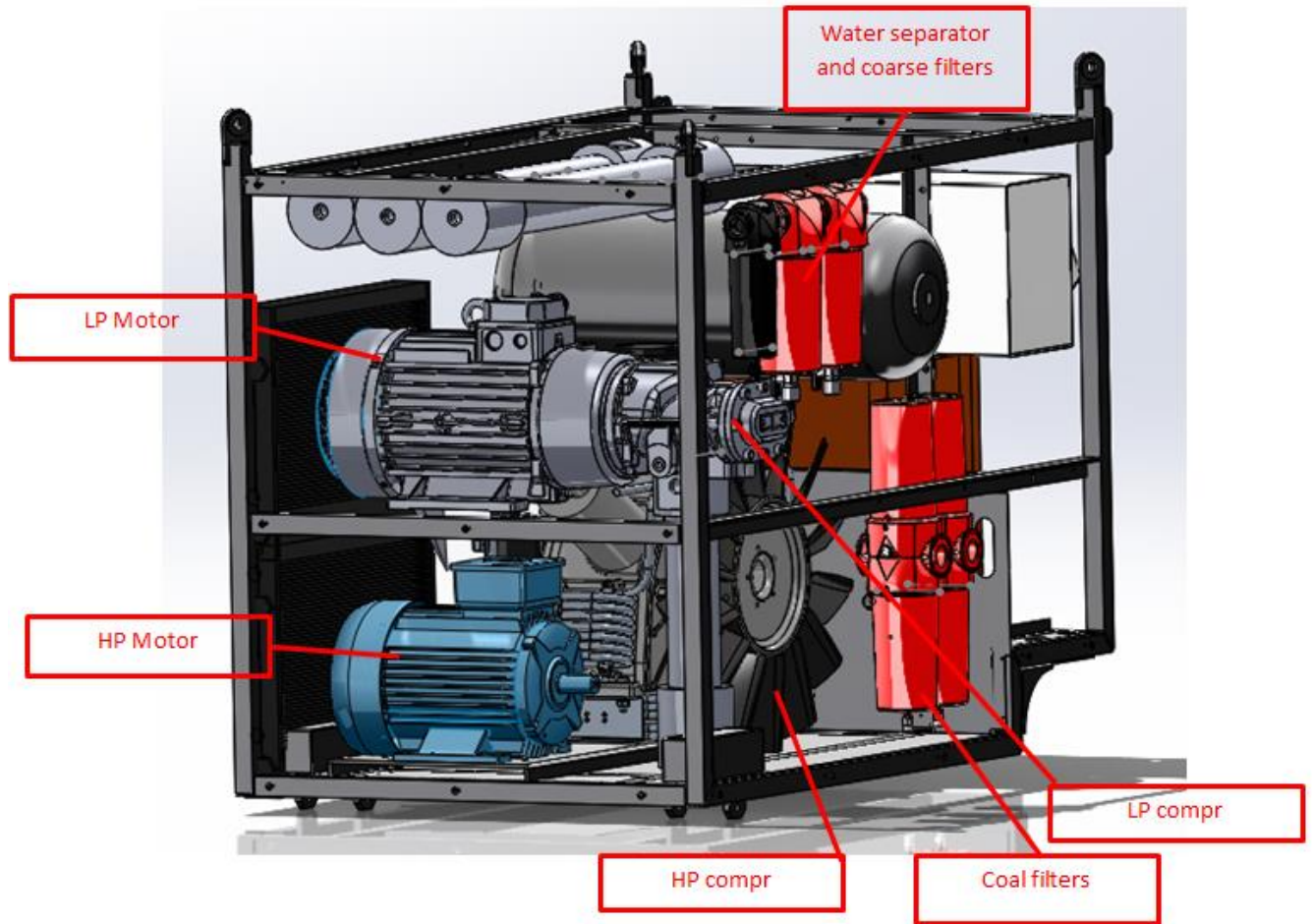

Figure 5.6 – Main components integrated in the frame design

The frame size is now according to the design criteria, but there is room for making the frame longer and higher if it's necessary for integrating all components.

During the test of the prototype, there will probably be changed out many components, and new components has to be fitted to frame.

## 5.2.Lifting Pad eye analyze:

Frame for the Nitrogen generator is constructed in aluminum 6082- T6.

### 5.2.1. Design criteria for the strength of the frame:

- Total weight of the unit 400 kg.
- Lifting onshore and internally on an offshore installation.
- Lifting points on all 4 corners for attachment for lifting accessories.

### Standards that are covering the design and lifting operation of the unit

- Norsok Standard R-002, Lifting equipment, edition 2, September 2012
- DNV 2.7-3 Portable offshore units, May 2011.
- Norsok Standard Z-015, Temporary equipment, nr 4, September 2012.
- Machine Directiv 2006/42/EC

Norsok R-002 is covering the design regarding lifting equipment on the Nitrogen Unit.

### Introduction of the Norsok R-002:

The main purpose of NOROK standard is to contribute to an acceptable level of safety for humans, the environment and material assets in the petroleum industry by giving technical requirements for lifting equipment.[13]

This NOROK standard is valid for technical requirements to lifting appliances and lifting accessories on all fixed and floating installations, mobile offshore units, barges and vessels, as well as on land based plants where petroleum activities are performed. This standard is also valid for material handling and the following equipment: [5]

- Launching and recovery appliances for life saving equipment, with and without lifting function;
- Means of connection and release systems that are integrated parts of life saving equipment, as well as their anchorage in the life saving equipment;
- Portable units;
- Foundations and suspensions for lifting appliances;
- Lifts.

### 5.2.2. Lifting shackle configuration

The Nitrogen generator will be design for onshore and internal lifting on an offshore installation.

Norsok R-002 main purpose is to make standard (requirements) for the offshore industry to convert some of the remaining lifting equipment from ISO Grade 6 shackles to ISO Grade 8 shackles. So it will not be possible to mix this in the future.

According to Norsok R-002, the unit is classified as Load Carrier R6 in annex C. Annex C is refereeing to Annex C for Portable units.

Annex F is referring the nitrogen unit is a Portable unit in group F3 and referring to DNV 2.7-3 as unit type A.

Further in Annex F it says: Requirements for fixed and detachable dedicated lifting points are given in Annex F, Group F5. [13]

Norsok R-002 F.7, Group F5 Lifted objects:

This group includes any loads not belonging to the other groups, which are not in themselves lifting equipment, but fitted with attachment points for lifting accessories for lifting onshore, internally on an offshore installation or between installation and vessel. Lifted objects also include objects with detachable transport skid/cradle. [13]

Examples of lifted objects may be

- Machines, components or equipment with fixed or detachable dedicated lifting points,
- Modules or structures with lifting point for intended for lifting during installation, maintenance and decommissioning.

Frame for the nitrogen generator is designed for lifting with an 4 part sling with an master link and top link. Figure 5.1.is an illustration of this from Norsok.



F.7.2.2 Lifting set terminology

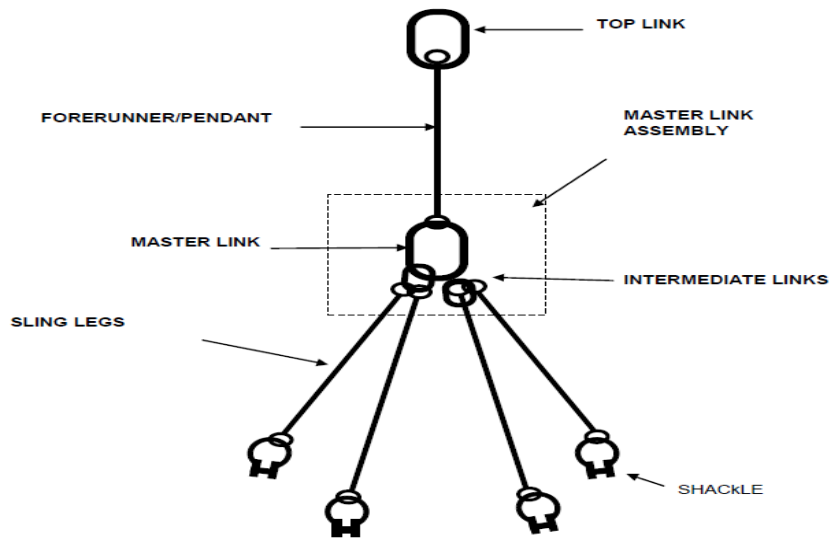

Figure F.3 - Terminology

Figure 5.7 – Illustration of an 4 part sling that the frame is designed for[13].

According to Norsok R-002 F.7.2.4.4, the shackles and rings on the lifting equipment has to be EN 13889 ISO Grade 8.

**5.2.2.1. Conclusion regarding the Lifting Equipment:**

**Design on the lifting pad eye is that it has to be designed for Grade 8 shackles.**

**5.2.3. Design and calculation of lifting shackles and lifting pad eye.**

Design and calculations are according to Norsok R-002 and DNV 2.7-3

Formula from Norsok is marked with red notation and has the same references as in Norsok. R-002.

### 5.2.3.1. Shackle calculation, according to Norsok R-002

#### F.7.2.3.2 Working load limit (WLL) (F1)

$$WLL = W * WCF$$

WLL = weight of the lifted object W including weight contingency and excluding the lifting sling set

W = estimated weight of the lifted object

WCF = weight contingency factor as defined in the table F.2 from Norsok.

From Table F.2.in Norsok R-002,  $W_{CF}$  is 1,1 for this design.

$$WLL = W * W_{CF}$$

$$WLL = 400 * 1,1$$

$$\underline{\underline{WLL = 440 KG}}$$

#### F.7.2.3.3 Centre of gravity (COG) envelope factor WCOG

For a non-weighed objects or objects with a complex weight pattern:

$$W_{COG} = 1,1$$

#### F.7.2.3.4 Skew load factor (SKL)

Single hook 4 point lift without spreader bar (statically indeterminate)

$$SKL=1,25$$

#### F.7.2.3.5 Dynamic amplifying factor (DAF)

Standard dynamic amplifying factor to be used when designing lifted objects and their corresponding lifting accessories shall be:

Onshore lifts and onboard lifts on fixed or floating installations:

$$DAF = 1,5 \text{ for } WLL \leq 50 \text{ ton}$$

### F.7.2.3.7 Material resistance factor, $\gamma_{Rm}$

Shackle and rings (including master links):

$$\gamma_{Rm} = 1,8$$

### F.7.2.3.8 Design factor (DF)

$$DF = \gamma_P * \gamma_C$$

$$DF = 1,34 * 1,25$$

$$\underline{DF = 1,68}$$

### F.7.3.1 Lifting point load for 4 point lift.

$$P_{LP} = \frac{WLL * b1 * a1 * W_{COG} * SKL * DAF}{L_{A-B} * L_{B-c}}$$

$$P_{LP} = \frac{440 * 630 * 385 * 1,1 * 1025 * 1,5}{1300 * 800}$$

$$P_{LP} = 211,6 \text{ KG}$$

### F.7.3.2 Required shackle size

Determination of required shackle:

$$MBL_{SHACKLE} \geq \frac{P_{LP} * \gamma_{Rm} * DF}{\cos \alpha_B}$$

$$MBL_{SHACKLE} \geq \frac{211,6 * 1,8 * 1,68}{\cos 45}$$

$$MBL_{SHACKLE} \geq 905 \text{ KG}$$

$$WWL_{SHACKLE} \geq \frac{MBL_{SHACKLE}}{\text{Safety factor}} = \frac{905 \text{ kg}}{8} = 113,1 \text{ kg}$$

Referring to Norsok, the shackles has to be EN 13889 Grade 8

Shackles According to En 13889 Grade 8 starts at 2,0 ton.

### 5.3. Pad Eye design criteria and calculation.

Ref; Norsok R-002 and DNV2.7-3

Lifting pad eye has to be designed for a 2, 0 ton Grade 8 shackle.

Gunnebo Lifting Artic Shackles No 856 Appendix A.6.

Main Data on this shackle are:

- Bolt Diameter d1: **16mm**
- Inside width at bolt, a: **21mm**

Design criteria for the Pad eye arrangement are from DNV 2.7-3 and Norsok R-002, appendix J.

#### **DNV2.7-3;**

##### 3.8.4 Pad eye geometry requirements

The outside radius of the pad eye main plate shall be no less than the diameter of the pin hole.

The pad eye thickness at the hole shall **not be less than 75%** the inside width of a shackle suitable for the RSF of the pad eye.

The pad eyehole diameter should be carefully selected to fit the shackle pin diameter. For strength purposes the difference in pad eyehole and pin diameter should be as small as possible, but shackle pin maximum diameter including tolerance should be considered in order to ensure that the pin will enter the hole.

**For pad eyes with significant (i.e. > 10%) out of plane loading, it is recommended that the shackle pin diameter is not less than 94% of the pad eye hole diameter.**

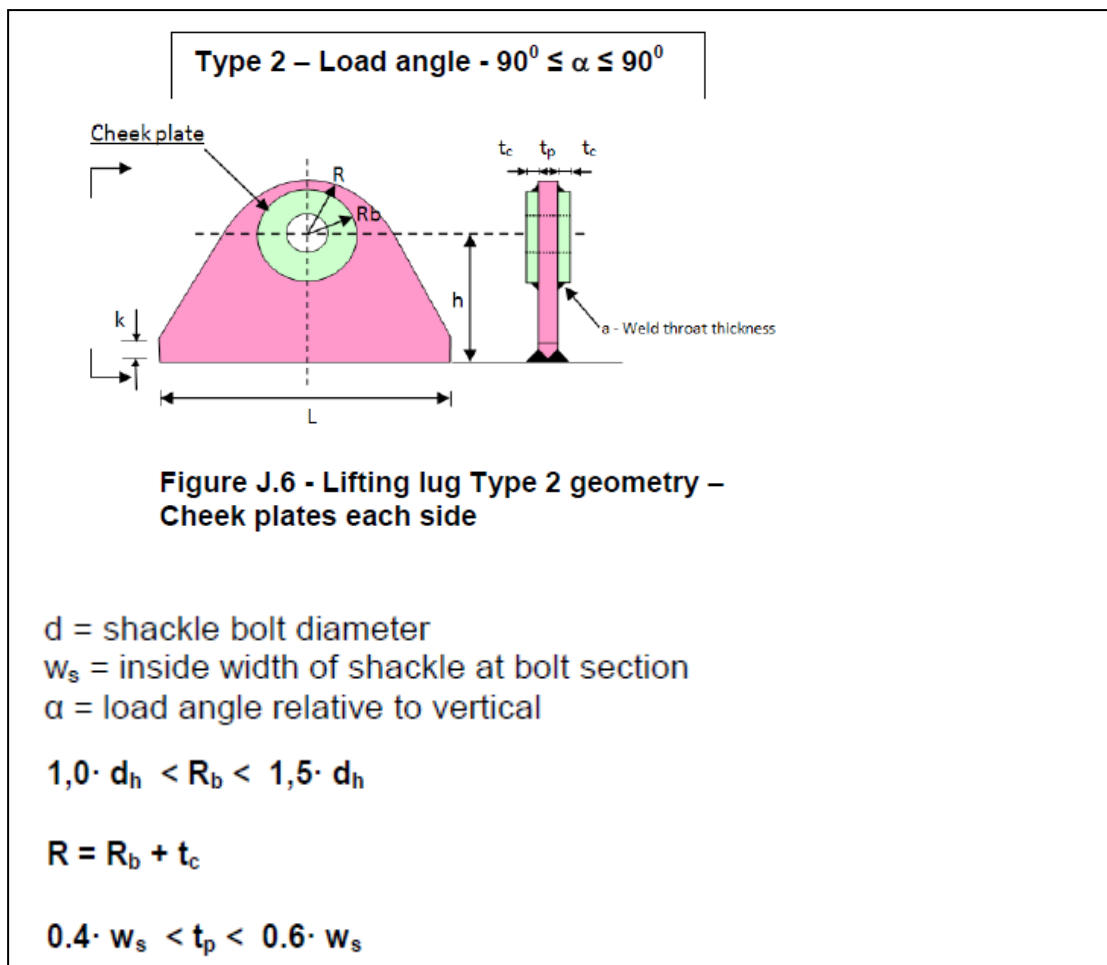

Figure 5.8 - Norsok R-002 appendix J, formulas for padeye calculation and design

Design of the lifting lug will be according to the illustration of figure J.6 in appendix J in Norsok R-002. [13]

From DNV 2.7-3:

**Maximum pad eyehole diameter  $d_h$  Max:**

$$d_h \text{Max} = d * 1,06$$

$$d_h \text{Max} = 16\text{mm} * 1,06$$

$$\underline{\underline{d_h \text{Max} = 16,96\text{mm}}}$$

**Nominal pad eyehole diameter,  $d_h$ :**

$$d_h = d * 1,03$$

$$d_h = 16mm * 1,03$$

$$\underline{\underline{d_h = 16,48mm}}$$

**Thickness of cheek plates,  $t_c$  and pad eye  $t_p$ :**

The pad eye thickness at the hole shall not be less than 75% the inside width of a shackle suitable for the RSF of the pad eye. [21]

The DNV 2.7.3 is referring to pad eye without cheek plates. So the total width of the pad eye with cheek plates has to be more than 75% of shackle width,  $w_s$ .

**Inside width on the shackle bolt section,  $w_s = 21$  mm**

$$(t_c + t_p)_{min} = w_s * 0,75$$

$$(t_c + t_p)_{min} = 21mm * 0,75$$

$$\underline{\underline{(t_c + t_p)_{min} = 15,75mm}}$$

**Thickness off pad eye with cheek plates, Norsok R-002, appendix J:**

$$0,4 * w_s < t_p < 0,6 * w_s$$

$$0,4 * 21mm < t_p < 0,6 * 21mm$$

$$\underline{\underline{8,4mm < t_p < 12,6mm}}$$

*This gives an opportunity to use standard 10 mm plate as pad eye.*

*Future calculations will have  $t_p = 10$  mm*

**Thickness off cheek plates  $t_c$ , Norsok R-002, appendix J:**

$$0,75 * w_s < t_p + 2 * t_c < 0,9 * w_s$$

$$0,75 * 21mm < 10mm + 2 * t_c < 0,9 * 21mm$$

$$\underline{\underline{15,75mm < 10mm + 2 * t_c < 18,9mm}}$$

*This indicate that the total thickness of pad eye and cheek plates have to be between 15,75 mm and 18,9 mm.*

**With a total thickness of 18,0mm,  $t_c$  will be:**

$$18mm = t_p + 2 * t_c$$

$$t_c = \frac{18mm - t_p}{2}$$

$$t_c = \frac{18mm - 10mm}{2}$$

$$\underline{\underline{t_c = 4,0mm}}$$

**Radius on cheek plates,  $R_b$  Norsok R-002:**

$$1,0 * d_h < R_b < 1,5 * d_h$$

$$1,0 * 16,48mm < R_b < 1,5 * 16,48mm$$

$$\underline{\underline{16,48mm < R_b < 24,72mm}}$$

*This indicate that radius  $R_b$ , on cheek plates have to be between 16,48mm and 24,72mm*

*Gives opportunity to use  $R_b=18mm$*

*Future calculations will have  $R_b=18mm$*

**Radius on Pad eye, R, Norsok R-002:**

$$R = R_b + t_c$$

$$R = 18 + 4,0mm$$

$$R = 22,0mm$$

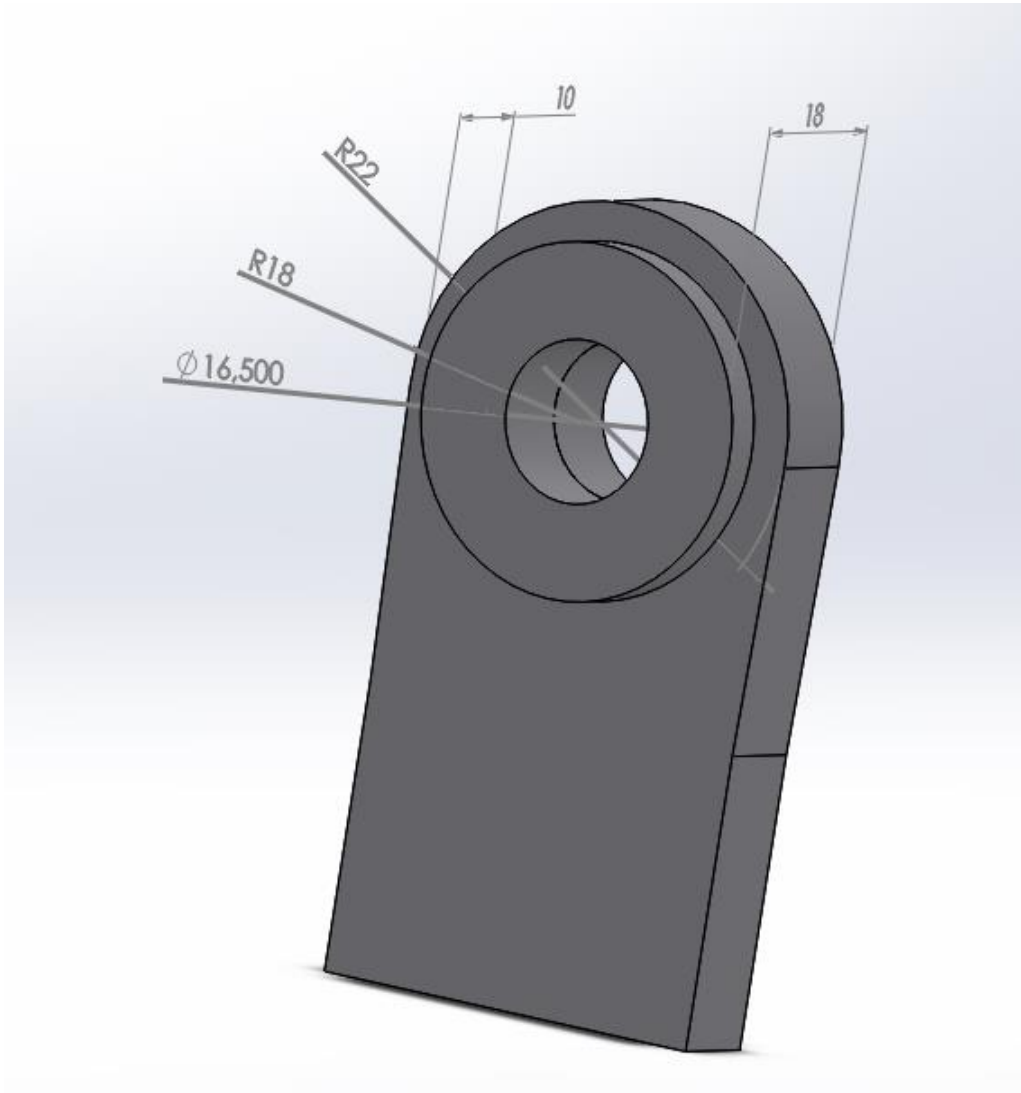

Figure 5.9 – 3D model of the designed lifting pad eye.

Lifting Pad eye was designed according to calculations and design criteria, see appendix 8 for drawings from this design. Analyze from load simulation was carried out in chapter 5.4.



#### 5.4.Simulation of lifting Padeye

Simulation of load on lifting arrangement was carried out using a non-penetration contact between shackle pin and padeye. **WWL=440Kg**

Lifting point load according to Norsok in chapter 5.2.3.1, formula F.7.3.1

$$P_{LP} = 211,6 \text{ KG}$$

With an  $P_{LP}$  of 211,6 kg, tension force on each sling will be

$$\text{Sling load} = \frac{P_{LP}}{\cos 45} = \frac{211,6 \text{ kg}}{\cos 45} = 299,2 \text{ Kg}$$

Lifting point load according to symmetric load

$$P_{LPsym} = \frac{WWL}{4} = \frac{440 \text{ kg}}{4} = 110 \text{ kg}$$

$$\text{Sling load (sym)} = \frac{P_{LPsym}}{\cos 45} = \frac{110 \text{ kg}}{\cos 45} = 155,6 \text{ Kg}$$

4-part sling that will be used is has WWL=1500KG, calculation using these parameters:

$$P_{LP1500} = \frac{WWL}{4} = \frac{1500 \text{ kg}}{4} = 375 \text{ kg}$$

$$\text{Sling load (sym)} = \frac{P_{LP1500}}{\cos 45} = \frac{375 \text{ kg}}{\cos 45} = 530 \text{ Kg}$$

Simulation was analyzed with and simulated force of 5300 N = 530 kg, since this was the “worst case” calculation.

Figure 5.10 is illustrating the direction of load. Use of a 4 part sling with sling length and hook length according to calculations in Appendix A.9 indicate that the load is 45 degree angular from at the lifting point.

The analysis of the lifting arrangement is setup as shown in figure 5.10, where

- A. is axial force to support shackle from moving
- B. is normal force support

C. is the tension of 5300 N

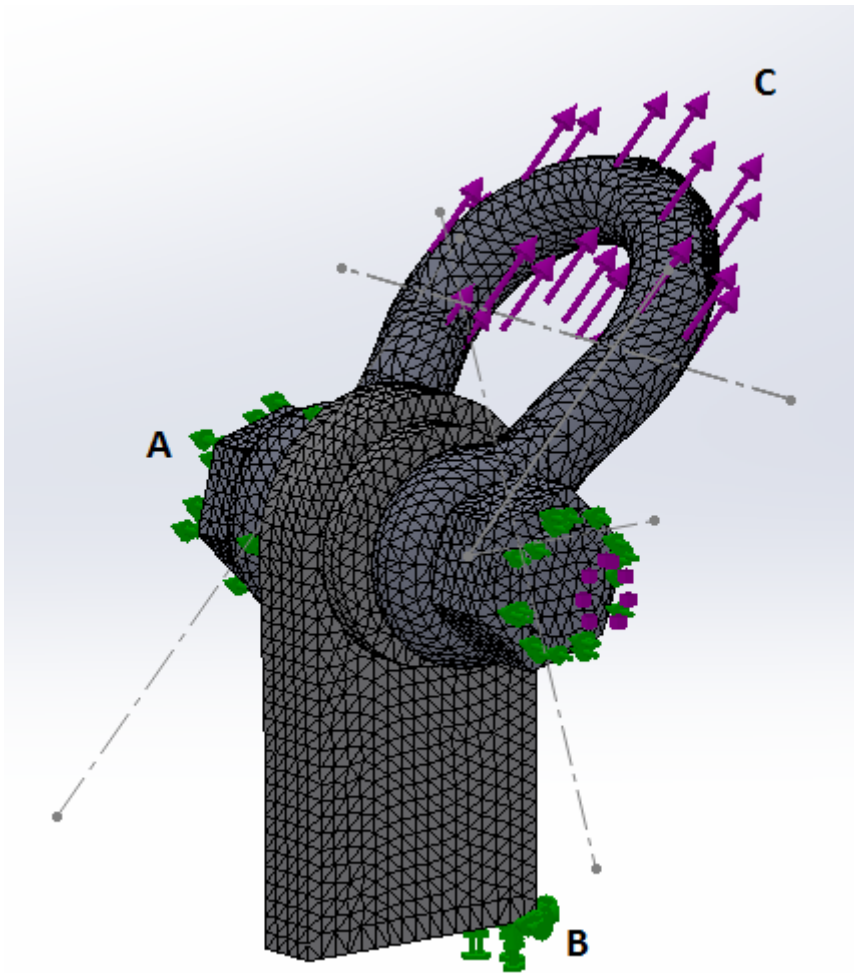

Figure 5.10 – Indication of direction of load on lifting arrangement

There was a problem to simulate this with the shackle attached due to problems with creating mesh points. Shackle was changed with a similar bolt that simulates the shackle. Figure 5.11.

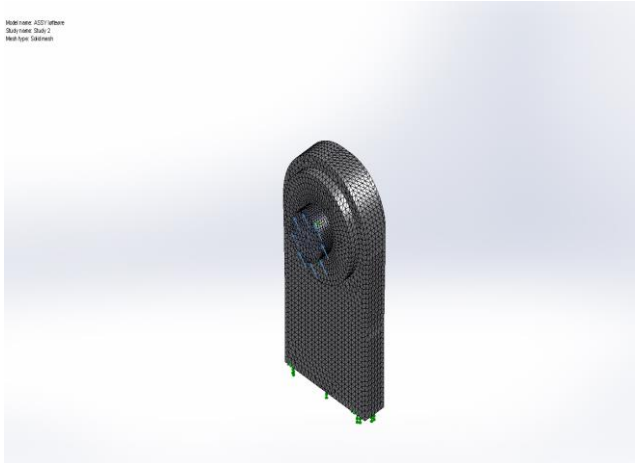

Figure 5.11 – Simulation with similar bolt

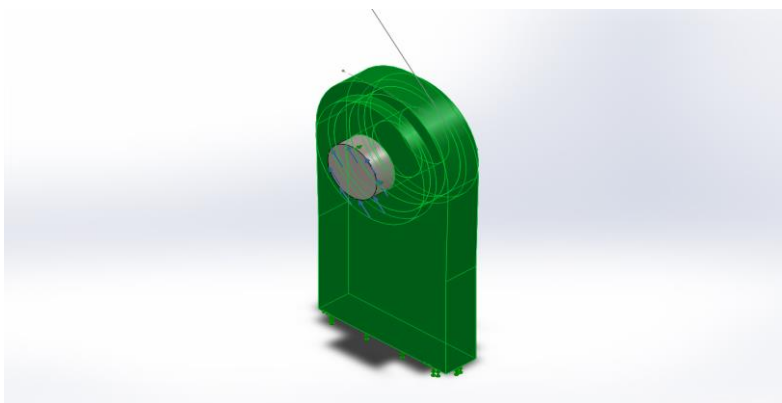
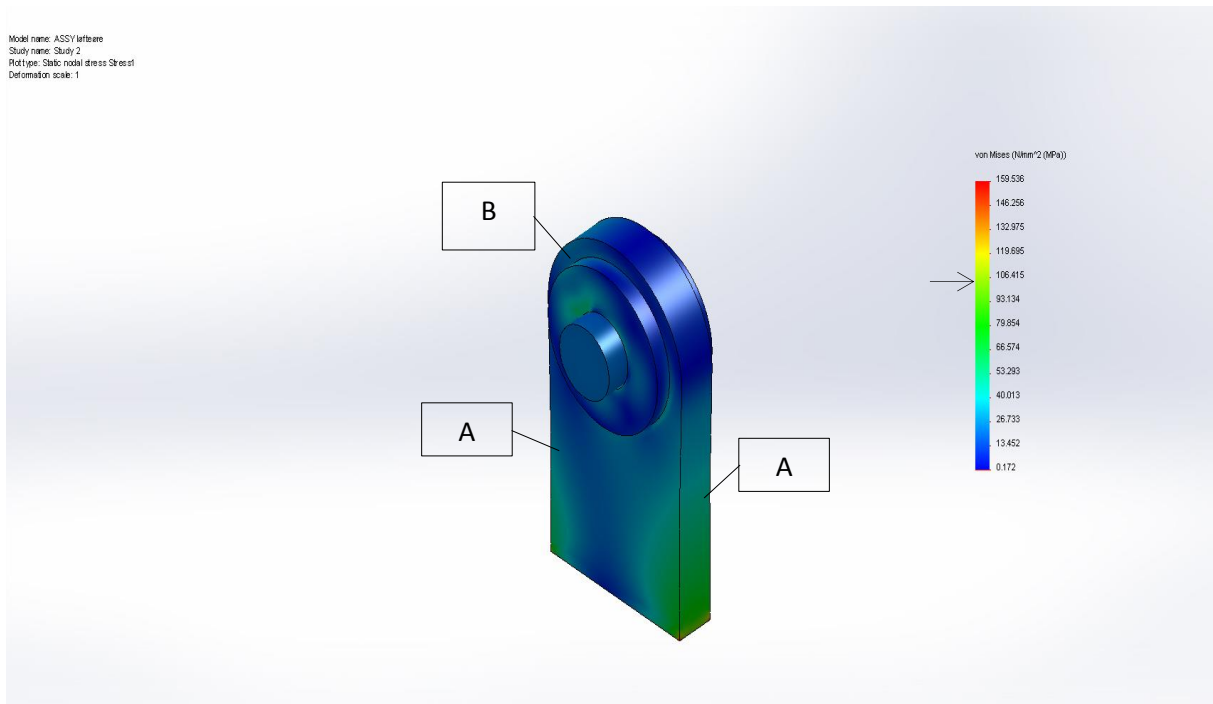

Figure 5.12 – Bounded conditions on the lifting arrangement

Figure 5.12 is indicating that the lifting plate and padeye (green color) is bounded, meaning that it's considered as one solid part (Simulating welding around the padeye). And the grey bolt is simulation the shackle bolt that is loos.



**Figure 5.13 – Overall stress distribution of the analysis**

According to figure 5.13, the result shows overall stress distribution of the analysis. The result indicates that stress level is below the limit of 310 MPa. The highest stress levels are at approx. 70 MPa around the region marked with A and B. Figure 5.14 is showing an ISO clipped image, here are the stress areas above 31 MPa shown and listed according to the color bar. This indicates areas that are higher than 1/10 (31MPa/310MPa) of the yield strength, indication of a safety factor of 10. This shows that the stress is in the same region of A and B, but there is no contact through the whole material, only minor stress greater than safety factor of 10. This part is sufficiently dimensioned.

Model name: ASSY Iarbare  
Study name: Study 2  
Plot type: Static node/stress Stress1  
Deformation scale: 1  
Element Volume = 24.43 %

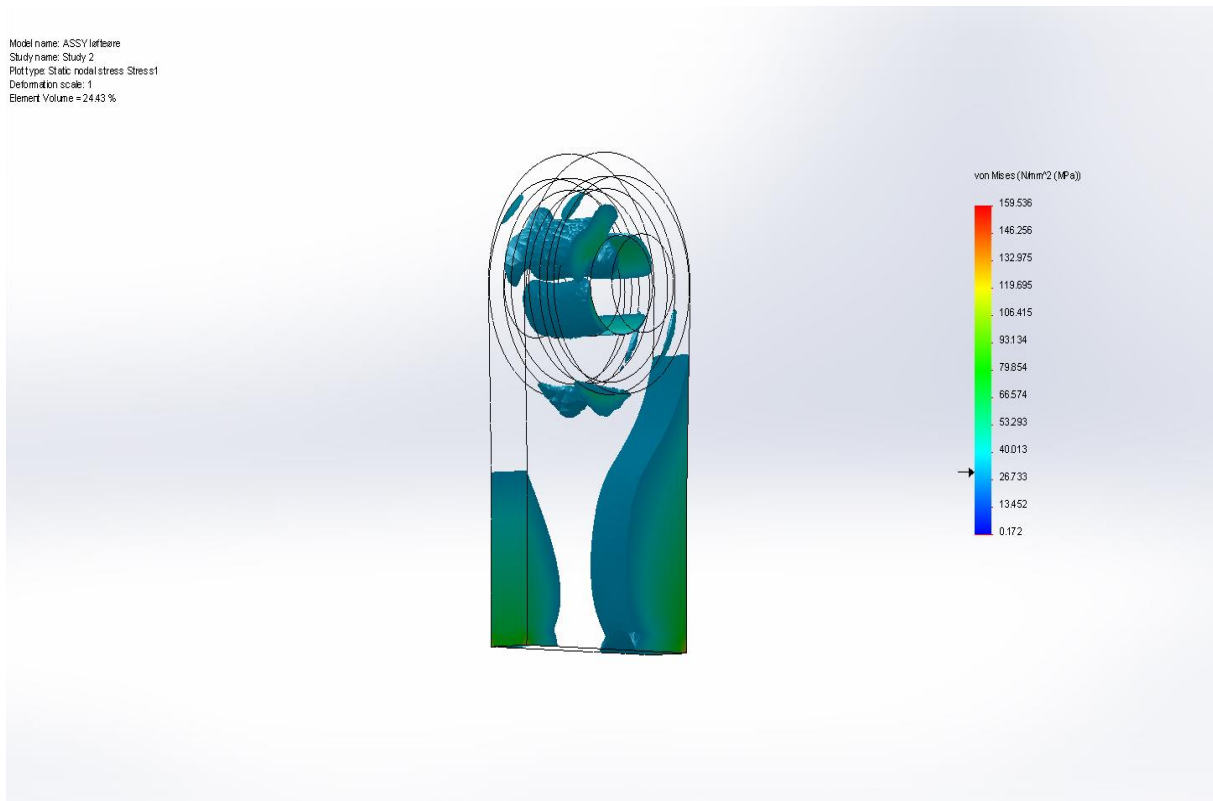

**Figure 5.14 – ISO clipped at 31 MPa SF=10**

Conclusion of the analysis is that the part is sufficiently dimensioned and retain a safety factor of SF=10.

Datasheet of alloy 6082 T6 is in appendix 12.

## 6. Conclusion and further work

### 6.1. Conclusion

The challenge for this master thesis has been to investigate the possibility of developing a suitable portable Nitrogen generator for use on offshore installation. The work has comprised defining the system functional requirements and establishing design criteria for such a unit. Several possible design solutions have been identified and then screen based on commercial and technical requirements, as shown in appendix A.13.

The overall objective has been to develop an easy to use "plug & play" unit, utilizing only electrical power supply to produce nitrogen from the surrounding atmosphere and to deliver the produced nitrogen at high pressure. This means that an air primary air compressor, nitrogen membrane and high pressure compressor have been integrated to one compact portable unit.

Design criteria and component design has been designed to fulfill applicable regulations and standards for equipment in an offshore oil and gas environment.

The thesis has covered the design of the processing equipment, where system solutions has been designed and individual components has been integrated.

Primary structure has been designed including lifting arrangement, using 3-D modeling, calculations and analyzing.

System design NG-003, with a separate LP compressor that are supplying the nitrogen membrane with air and then one HP compressor that can deliver pressure up to 300 bar (g) is the best solution. The prototype will be designed according to this and give a calculated N<sub>2</sub> production capacity of:

- 560 l/min @ 8 bar, 95 % purity
- Or
- 300 l/min @ 300 bar, 95% purity
- And
- 260 l/min @8 bar, 95% purity

With a separate LP and HP compressor, Nitrogas nitrogen generator will be able to deliver LP nitrogen and HP nitrogen. This will give Nitrogas an advantage in the marked.

This thesis provides a solution for a system and components that can be integrated together and make the basic of a portable nitrogen generator for use in the oil and gas industry.

All main components for the nitrogen generator prototype have been ordered and construction of this will start in July/August 2013.

During the thesis I have used solid works for 3D modeling and analyze and Smart draw for system design. I have learned system design, project development, working with 3D modeling and analyzing and the technology about how nitrogen can be produced and the science around this.

## **6.2. Future work**

The prototype test will give a good indication about the nitrogen production capacity on the generator. Designed with LP compressor capacity of 1750 l/min and calculated to give a nitrogen production of 560 l/min. with use of an 11 KW motor.

Based on the test result, it will be easier to decide regulating methods for the LP motor and the challenges around the electrical configurations.

There are three options for the LP motor:

- Variable speed with an frequency converter.
- 2 speed motor (Dalhander)
- Fixed speed.

Future work that is not settled, is the electrical control system, this will be a challenge to get all components integrated into an Atex zone 1 configuration.

Optimizing components and parts for configure it into the portable unit criteria.

## 7. References

- [1] IKMs homepage: *gas booster*.  
[www.ikm.no](http://www.ikm.no)
- [2] Hamworthys homepage: *Nitrogen generators*.  
<http://www.hamworthy.com/en/>
- [3] Gasatsites homepage: *Nitrogen articles*.  
<http://www.gasatsite.com/nitrogen.html>
- [4] Gassystem corporations homepage: *Nitrogen membrane*.  
[http://www.gassystemscorp.com/1\\_pdf/Membrane%20Air%20Separation.pdf](http://www.gassystemscorp.com/1_pdf/Membrane%20Air%20Separation.pdf)
- [5] Atlas copcos homepage: *Nitrogen generators*  
<http://www.atlascopco.com>
- [6] Branicks homage: *Nitrogen generators*  
<http://www.branick.com/n2-model-685.phpDghj>
- [7] IGS-Genron homepage: *Nitrogen generators*  
<http://igs-global.com/products/prod-NMS.html>
- [8] Nitrogen genrators homepage:  
<http://www.nitrogen-generators.com/default>
- [9] Gassystem corporations homepage: *Nitrogen membrane*  
<http://www.gassystemscorp.com/nitrogen-generator-nitrogen-membranes.asp>
- [10] Parkers homepage: *Parker Hifluxx*  
[www.Parker.com](http://www.Parker.com)
- [11] Chemical engineering's homepage: *Nitrogen generator*  
<http://www.cheme.cmu.edu/course/06302/airsep2/Part2.html>
- [12] E Innovation internal drawing of the E compressor.
- [13] Norsok R-002



- [14] Compressor world's homepage: *oil less scroll compressor*.  
<http://www.compressorworld.com/>
- [15] Hydro vanes homepage: *rotary vane principle*  
[http://www.hydrovaneproducts.com/Why\\_Hydrovane/01Rotary\\_Vane\\_Principle.aspx](http://www.hydrovaneproducts.com/Why_Hydrovane/01Rotary_Vane_Principle.aspx)
- [16] Maximator homepage; *air driven high pressure pump*.  
[www.Maximator.no](http://www.Maximator.no)
- [17] Bauer's homepages: *Nitrogen booster*  
[http://www.bauer-kompressoren.de/pdf/produkte/atemluft/mini\\_verticus\\_3\\_en.pdf](http://www.bauer-kompressoren.de/pdf/produkte/atemluft/mini_verticus_3_en.pdf)Jdj
- [18] Nardi compressoris homepage: *high pressure compressor, pacific*.  
<http://www.nardicompressori.com/>
- [19] Inmatecs homepage; *Nitrogen generators*.  
<http://www.inmatec.de/>
- [20] Airbest practices homepage; *article from Mike Flowe*.  
<http://www.airbestpractices.com/system-assessments/air-treatment/n2/energy-costs-associated-nitrogen-specifications>
- [21] DNV 2.7-3 Portable offshore units, May 2011.
- [22] Prime crane services homepage; *Lifting calculation application*  
[www.primecraneservices.com](http://www.primecraneservices.com)

## A.1. New parts for the installation of Hitachi 5,5KW scroll compressor.

### Contents

Part nr 300003.....	83
Part nr 300004.....	83
Part nr 300001.....	84
Part nr 300002.....	84
Assambly nr 300080.....	85
Part nr 300005.....	85
Part nr 100270.....	86
Part nr 300007.....	86
Assembly nr 300014.....	87
Part nr 300087.....	87
Part nr 300476.....	88
Part nr 300276.....	88
Part nr 300480.....	89
Part nr 300486.....	89
Part nr 300487.....	90
Part nr 300488.....	90
Part nr 300485.....	91
Part nr 300489.....	91

**Part nr 300003**

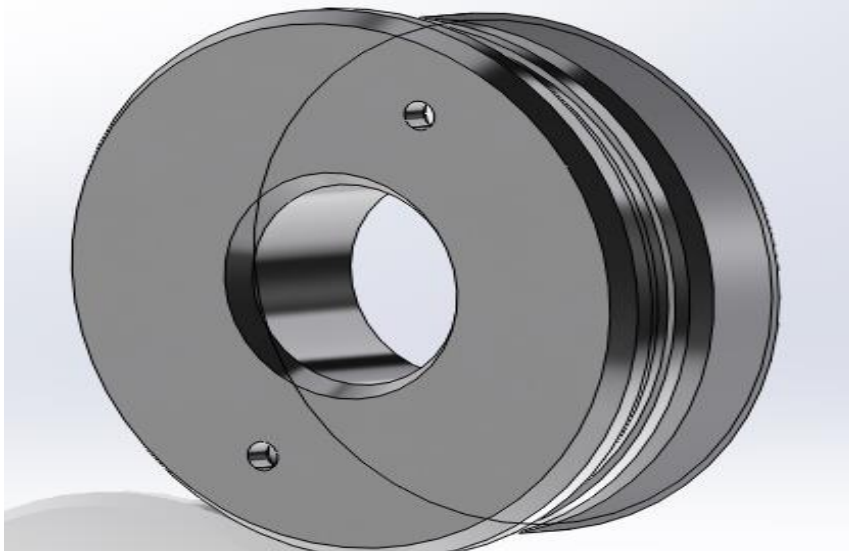

**Part nr: 300003**  
**Model name: Inlet filter back unit**

**Part nr 300004**



**Part nr: 300004**  
**Model name: Inlet filter front unit**

*Part nr 300001*

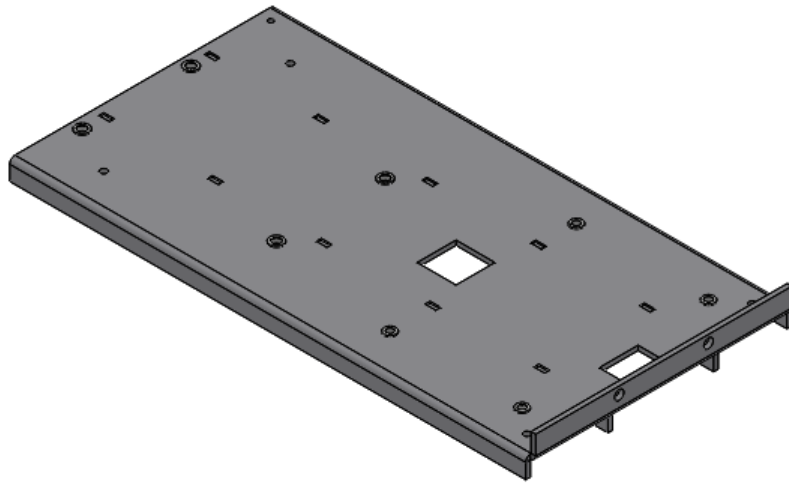

**Part nr: 300001**  
**Model name: Motor/Scroll mounting plate**

*Part nr 300002*



**Part nr: 300002**  
**Model name: Inlet flange for compressor**

*Assambly nr 300080*

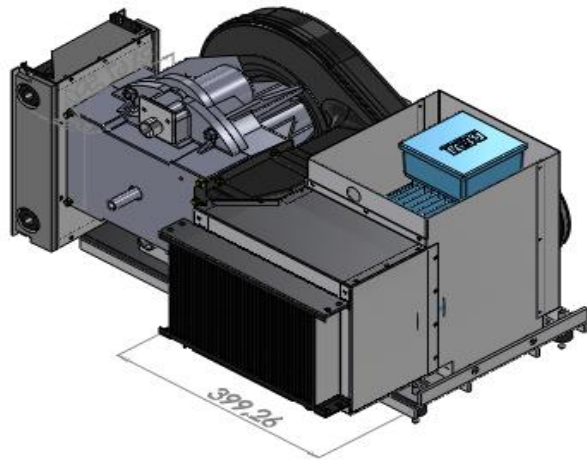

**Part nr: 300080**  
**Model name: New scroll assembly**

*Part nr 300005*



**Part nr: 300005**  
**Model name: Beam for motorplate 300001**

*Part nr 100270*



**Part nr: 100270**  
**Model name: Inlet air hose crossover**

*Part nr 300007*

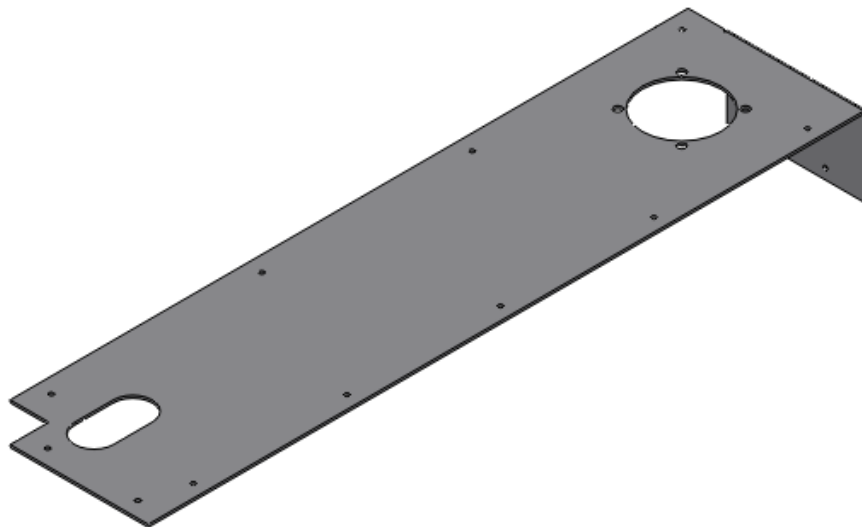

**Part nr: 300007**  
**Model name: Midplate**

*Assembly nr 300014*

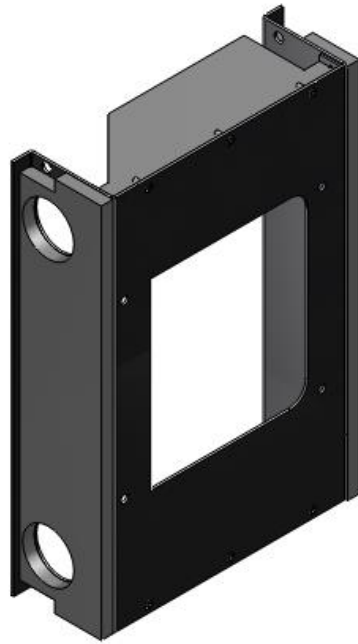

Part nr: 300008, 300009, 300010, 300011, 300012, 300013  
Model name: 1<sup>st</sup> cooler assy

*Part nr 300087*

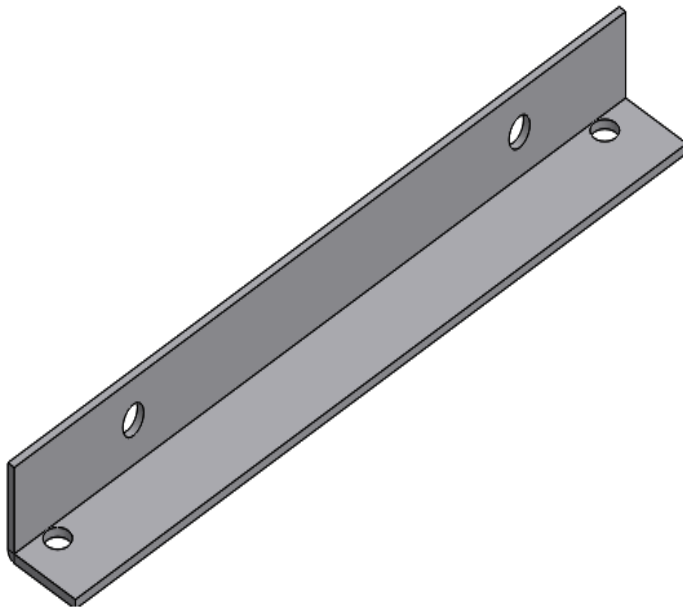

Part nr: 300087  
Model name: Bracket for part nr 300014

*Part nr 300476*

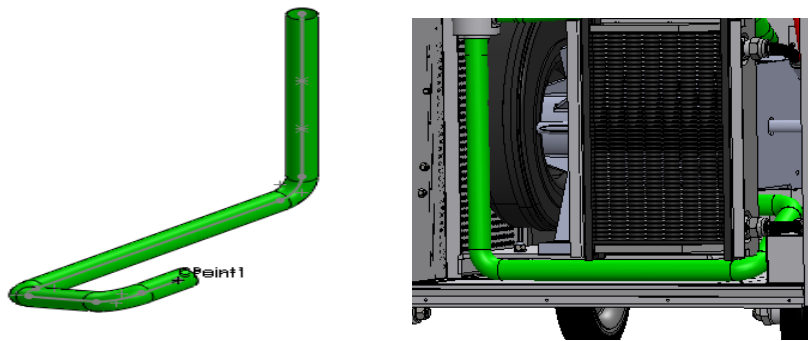

**Part nr: 300476**  
**Model name: Lower Inlet air hose.**

*Part nr 300276*

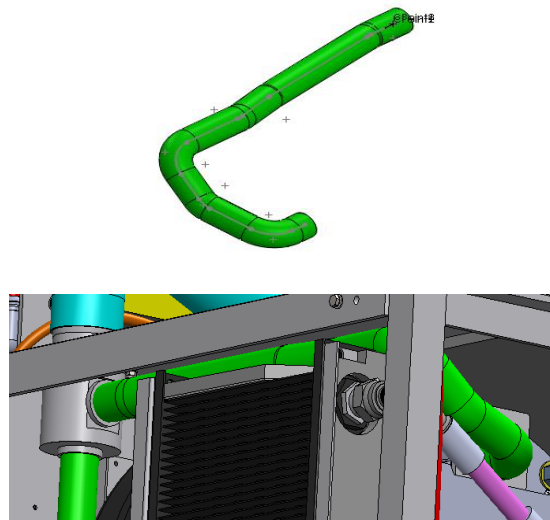

**Part nr: 300276**  
**Model name: Upper Inlet air hose.**



*Part nr 300480*

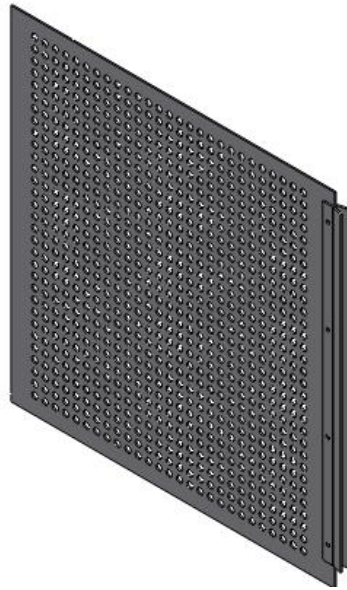

**Part nr: 300480**  
**Model name: Scroll cover plate**

*Part nr 300486*

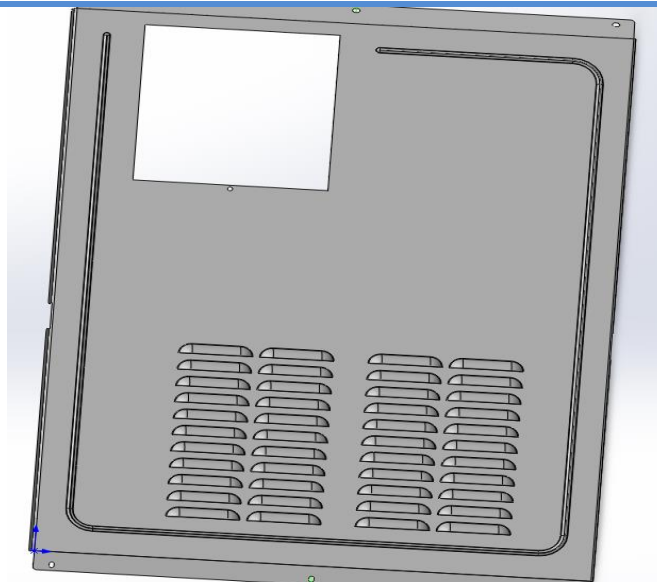

**Part nr: 300486**  
**Model name: Back cover plate**

*Part nr 300487*

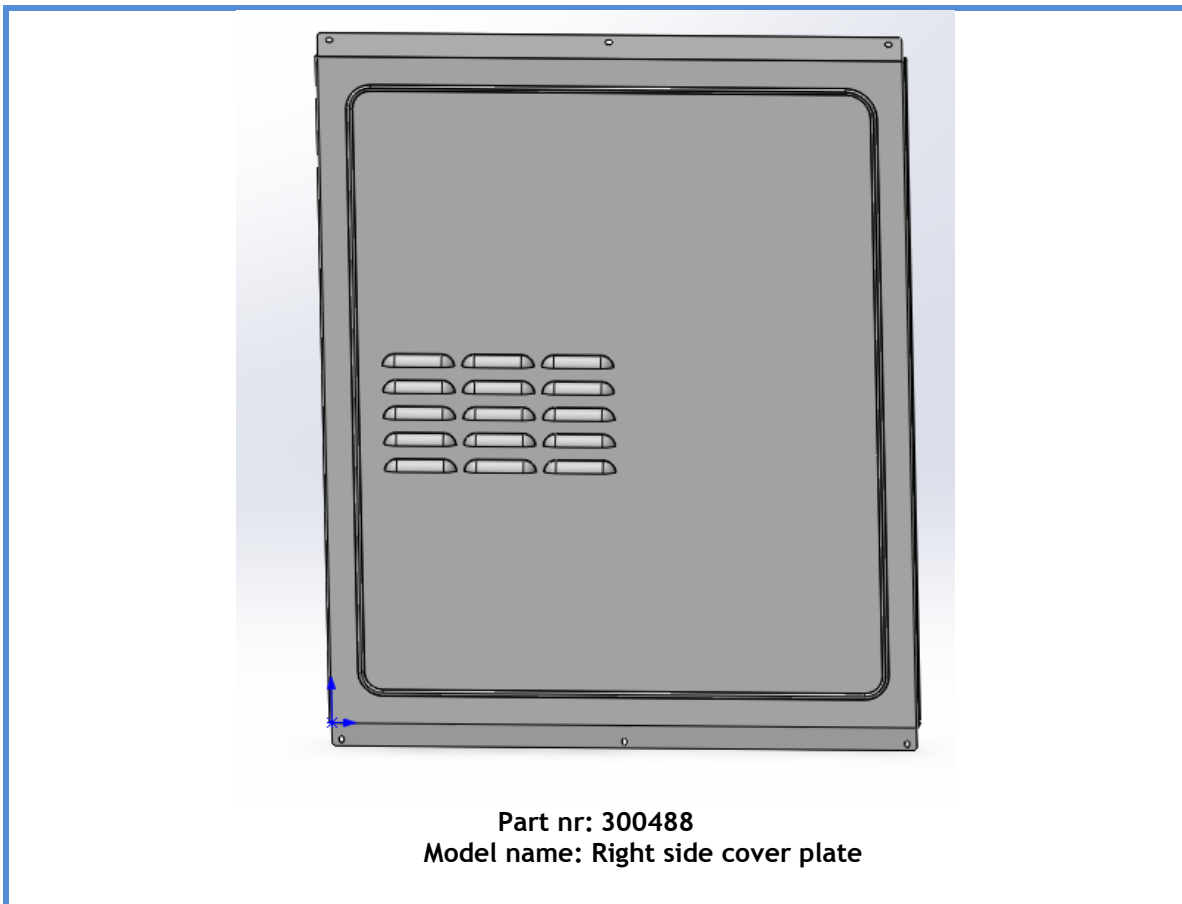

*Part nr 300488*

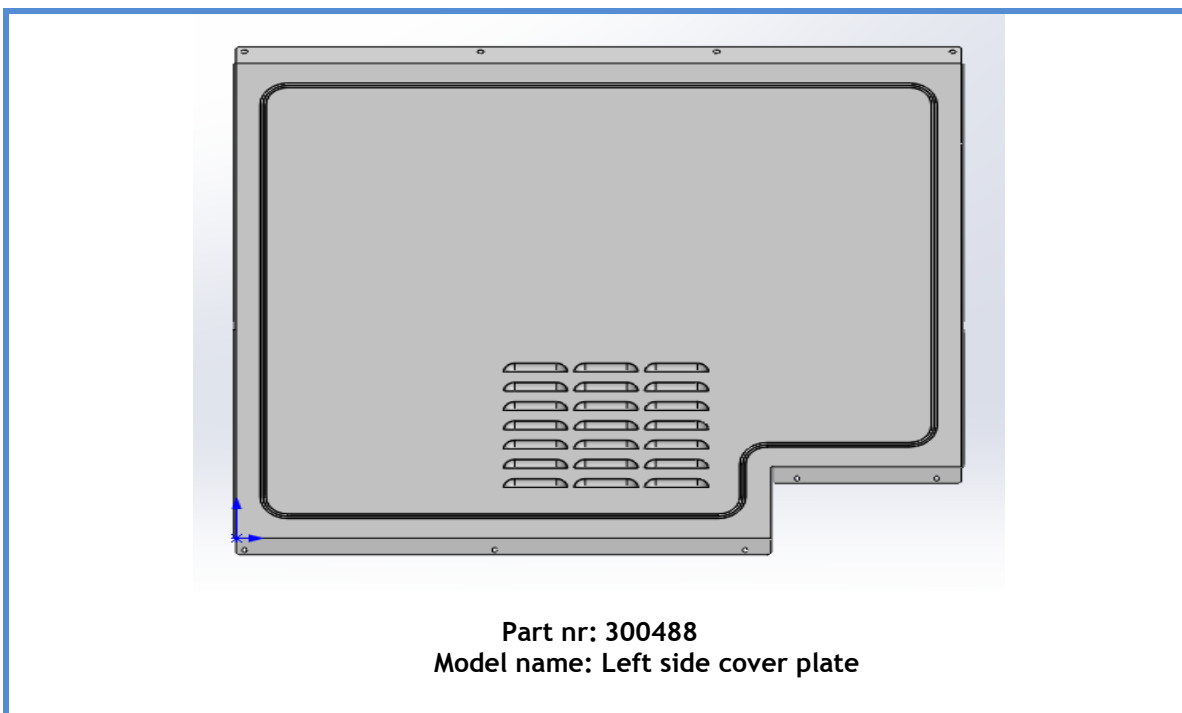

*Part nr 300485*

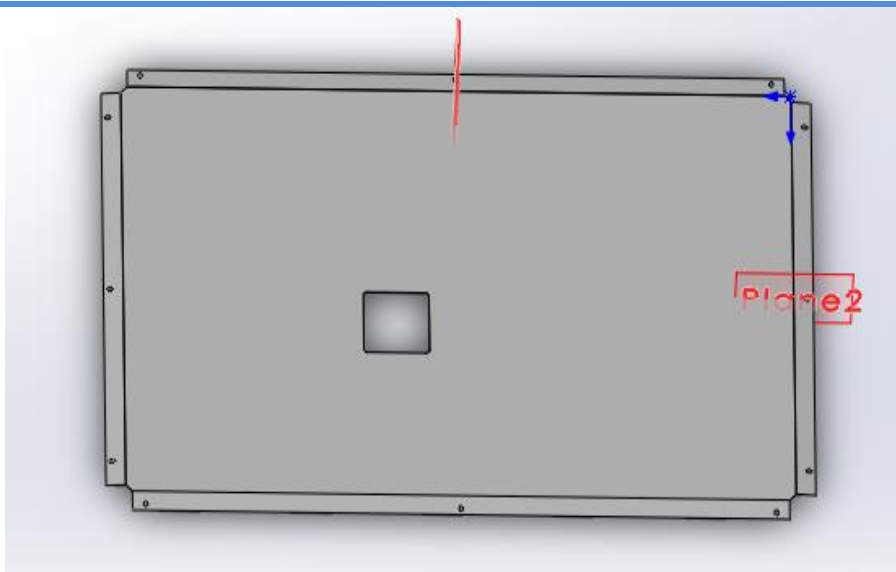

**Part nr: 300485**  
**Model name: Top side cover plate**

*Part nr 300489*

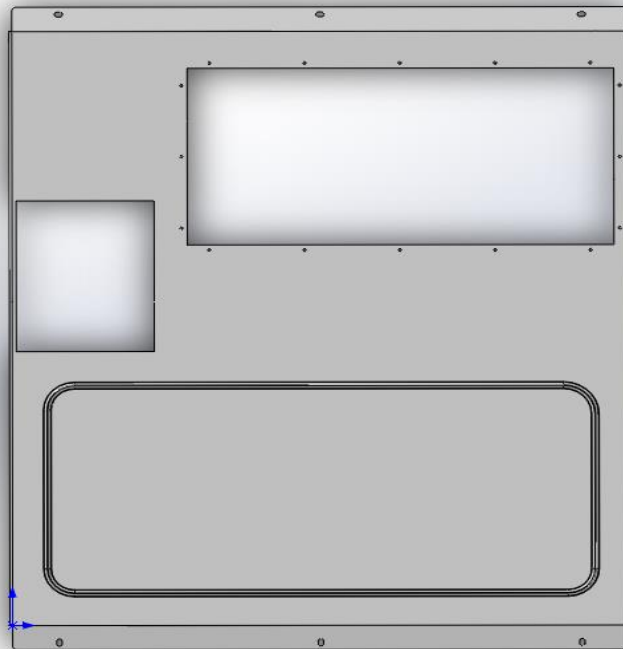

**Part nr: 300489**  
**Model name: Front side cover plate**

## A.2. Fini Compressor FSC 50 -11KW

### GRUPPI VITE-MOTORE | PACKAGE FSC 50 11-15 kW

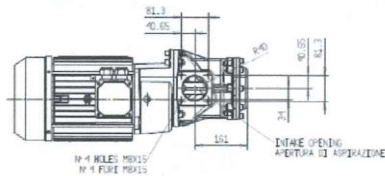
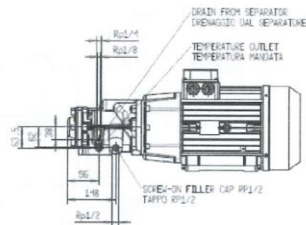
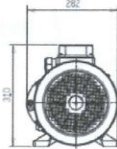
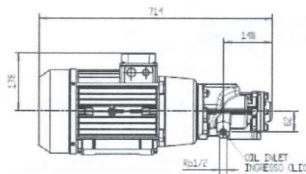
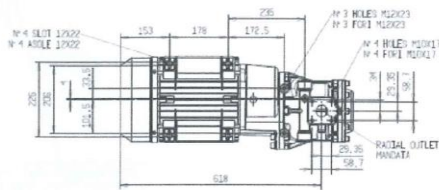

Performance data	Model	FSC50 11 kW Package			FSC50 15 kW Package		
Maximum working pressure	bar g	8	10	13	8	10	13
Minimum working pressure	bar g		5			5	
Air-end	Type	FS50TFC11	FS50TFC20	FS50TMC	FS50TFC	FS50TFC20	
Drive rotor rate	rpm		2850		2850		
FAD (According ISO1217 annex C)	l/min	1750	1550	1200	2050	1600	
Ambient temperature min/max	°C		+2/+45		+2/+45		
Heat rejected by ventilating fan	kJ/h		37600		51300		
Drive motor type	Type		132MC/2		132MC/2		
Max restarting per hour	n°		10		10		
Electric data							
Input voltage main motor	V/ph/hz	400/3/50			400/3/50		
Nominal main motor rating	kW	11			7,5		
Total input power package incl.fan	kW	13,5			16,6		
Full load current (400 V)	Amp	22,6			26,5		
Starting current	Amp	68			80		
Main motor protection degree	IP	55			55		
Main motor insulation class		F			F		
Weights and Dimensions							
Compressed air delivery connection	pollici	3/4"			3/4"		
Weight	kg	84			92		
Package dimensions LxWxH	cm	72x28x31			72x28x31		

## Parts for an FSC 50 -11KW

cod: DCIO-8G3CZ2

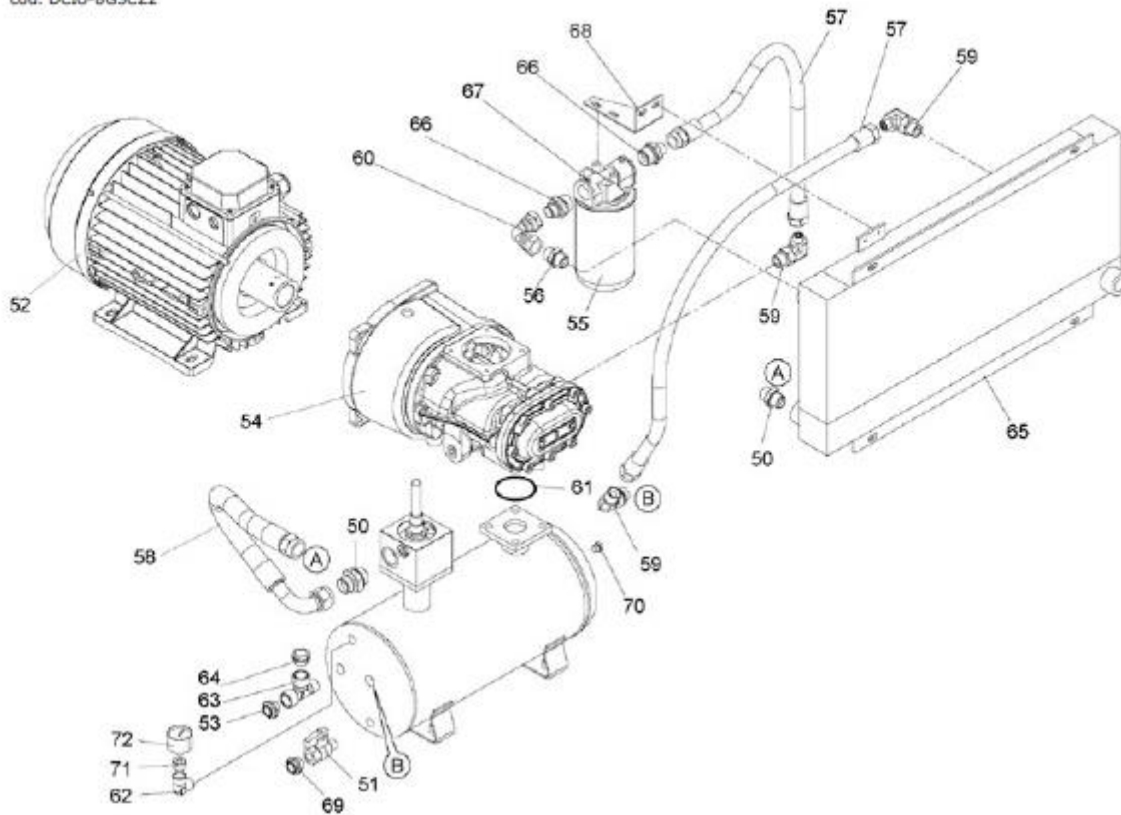

Rif	Codice	Descr.	Qtà	Cons.	cod: 002
50	011470000	NIPPLO 3/4+OR#	2	-	
51	322055000	RUBIN.LINEA A SFERA G3/8 MF(M/CON.)FIV	1	-	
52	540M072622	MOT.EL.VE132M 15CV 400/690 50/60 2P KMAX	1	-	
53	012099000	SPIA LIV.OLIO 1/2" HP ALL	1	-	
54	5304000460	VITE PS 50TFC20	1	-	
55	048444000	FILTRO OLIO FSN W950/17	1	10	
56	011255000	NIPPLO ADATTA1/2X1/2	1	-	
57	151300019	TUBO OLIO RADIATORE-VITE	2	-	
58	1603L0038	TUBO ARIA COLL.MPV-RAD-BSC10-15 EVOL	2	-	
59	011453000	RACC.GIUNZ.90°1/2+OR	3	-	
60	011494000	CURVA 90 FF 08 1/2	1	-	
61	010054000	ANELLO OR 4187 VITON	1	-	
62	011136000	RACCORDO L MF R3/8	1	-	
63	011353002	RACC.LINEA T MFF R1/2	1	-	
64	011000389	TAPPO G1/2 ESAG. INC.+ OR VITON	1	-	
65	048512000	RADIATORE ARIA-OLIO	1	-	
66	011000275	NIPPLO ADATTA1/2X3/4 SMUSSO 30°	1	-	
67	1603L0011	TESTINA PORTA FILTRO BSC EVOL	1	-	
68	160PU0017	STAFFA X TESTINA PORTA FILTRO K-MAX 1520	1	-	
69	012023000	TAPPO SCARICO OLIO TSN 38 G3/8"	1	-	
70	111008000	TAPPO GC1/2 ACC.CH10 TRATT.DRY LOC 2040	1	-	
71	011123000	RIDUZIONE G3/8X1/8 OT ZINC	1	-	
72	330060000	MANOM.GLICERINA D40 0-16 .R1/8"	1	2	

# GRUPPI VITE | AIR END

# FS26 TF 5,5-15 kW

Gruppo vite tipo: Air-end type:	<b>FS26 TF</b>	
Comando Drive	Accoppiamento diretto o per cinghia Direct by coupling or belt	
Dimensione Rotore Maschio Male rotor dimension	Ø71.5	mm
Diametro esterno vite conduttrice Outside main diameter	Ø67.5	mm
L/D	1,535	
Portata (ISO 1217 annex C 1996) Air capacity	0.46-1.8	m <sup>3</sup> /min
Pressione Max lavoro Max Working Pressure	15	bar g
Pressione Min lavoro Min Working Pressure	5	bar g
Portata olio iniettata Oil injected quantity	25	l/min
Massima potenza assorbita Max input Power	15	kW
Max velocità all'albero Max main rotor speed	5300	rpm
Min velocità all'albero Min main rotor speed	1400	rpm
Temperatura ambiente Max / Min Max / Min Ambient Temperature	50 - 0	°C
Peso Weight	15	kg
Diametro Albero Shaft diameter	Ø28 k6	mm

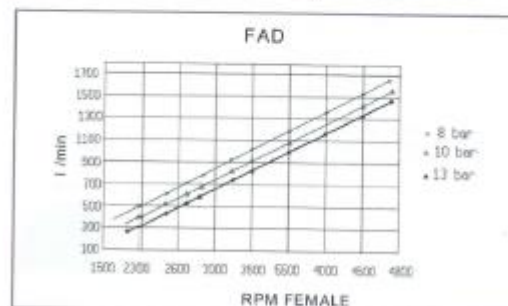
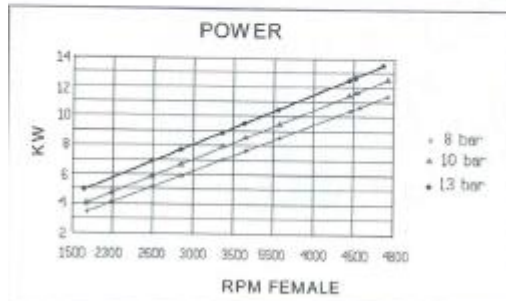

### A.3. Nardi HP Compressor Pacific



**New line Pacific E**  
**Nuova linea Pacific E**

Aluminum and stainless steel Frame  
Telajo in alluminio e acciaio Inox

New purification filter  
Nuovo sistema filtrante

\* New electronic control  
\* Nuovo controllo elettronico

\* New condensate drain system with PATENTED low-flow  
\* Nuovo scarico condensa BREVETTATO

\* Handle for easy transport  
\* Manico per un facile trasporto



**Dimension**  
**Dimensioni**

Lenght - Lunghezza 99 cm - 39 in  
Width - Profondità 53 cm - 21 in  
Height - Altezza 65 cm - 25,6 in



water resistant frame  
aluminum - stainless steel

All technical data may be changed without notice  
Le caratteristiche tecniche e i dati forniti possono subire modificazioni  
MADE IN ITALY by NARDI COMPRESSORI

Art. PACIFIC E 2012 (ING-ITA)

Rev. 01/2013

Proprietà © NARDI COMPRESSORI

# PACIFIC E



Model Compressor	Modello Compressore	Nome Nome	PACIFIC E 16		PACIFIC E 23		PACIFIC E 27		PACIFIC E 30 NEW UNIT 2012		PACIFIC E 35	
Working Pressure	Pressione di esercizio	PN	200	300	200	300	200	300	200	300	200	300
Charging rate**	Aria Resa**	l/min - m <sup>3</sup> /h - dm <sup>3</sup>	160 - 9,6 - 5,6		230 - 13,8 - 8,13		270 - 16,2 - 9,54		300 - 18 - 10,6		350 - 21,0 - 12,37	
Safety Valve Pressure	Pressione di esercizio	Bar - Psi	225 - 3200	330 - 4700	225 - 3200	330 - 4700	225 - 3200	330 - 4700	225 - 3200	330 - 4700	225 - 3200	330 - 4700
Compressor block	Gruppo pompante	Nome - Nome	PACIFIC 17		PACIFIC 23		PACIFIC 28		PACIFIC 32		PACIFIC 35	
Number of stages	Numero di stadi	N°	3		3		3		3		4	
Number of connecting rods	Numero di bielle	N°	3		3		3		3		3	
Pressure 1st Stage	Pressione 1° stadio	Bar / Psi	5 - 72		7,5 - 110		7,5 - 110		7,5 - 110		3 - 43	
Pressure 2nd Stage	Pressione 2° stadio	Bar / Psi	55 - 800		65 - 940		65 - 940		65 - 940		16 - 230	
Pressure 3rd Stage	Pressione 3° stadio	Bar / Psi	225-3200	330-4700	225-3200	330-4700	225-3200	330-4700	225-3200	330-4700	80-1160	
Pressure 4th Stage	Pressione 4° stadio	Bar / Psi	-		-		-		-		225-3200	330-3200
Compressor Block Oil capacity	Capacità coppa dell'olio	Liter - gal(US)	3,5 - 0,924		3,5 - 0,924		3,5 - 0,924		3,5 - 0,924		3,5 - 0,924	
Speed Compressor	Giri Compressore	r.p.m.	1350		1350		1550		1450		1550	
Oil Type	Tipo di Olio	Nome - Nome	NARDI SYNTHETIC 150									
Environment working temperature	Temperatura ambiente di lavoro	°C / °F	From +5°C to +45°C / From +41°F to +113°F									
Max inclination of compressor	Max inclinazione del compressore	Grade - Gradl	20° *		20° *		20° *		20° *		20°	
Max operating height	Max altezza dal livello del mare	Meter / Feet	2000 / 6500		2000 / 6500		2000 / 6500		2000 / 6500		2000 / 6500	
Power pump weight	Peso gruppo pompante	Kg. / lb	47 / 103		47 / 103		47 / 103		47 / 112		51 / 112	
Dry and oil intermediate separator	Separatori acqua olio	N°	2		2		2		2		3	
Filtration	Sistema Filtrante	Nome - Nome	PAC 1 ***		PAC 1 ***		PAC 1 ***		PAC 1 ***		PAC 1 ***	
Interstage coolers and after coolers	Tubi di raffreddamento	Material - Materiale	Acciaio Inox - Stainless Steel									
Breathing air	Aria respirabile	Directives - Direttive	UNI EN 12021:2000 - AFISI/CGA E - Z180									
Filling time single cylinder 10 L. 0-230 Bar	Tempo ricarica bombola 10 L. 0-200 Bar	Min.	12': 30"		08': 46"		07': 26"		06': 44"		05': 47"	
Electric Motor	Motore elettrico	Phase - Fasi	Single		Three		Three		Three		Three	
Operating Voltage	Tipo di Voltaggio	Volt / Hz	230		230 ⇄ 690		230 ⇄ 690		230 ⇄ 690		230 ⇄ 690	
Power	Potenza Motore	Kw	3		4		5,5		5,5		7,5	
Noise level	Pressione Sonora	dB	74		77		80		78		82	
Type of enclosure	Protezione	IP	54		54		54		54		54	
Current Rating	Assorbimento	Ampere	15,6 (230)		15,1(230)-8,7(400)		19(230)-11(400)		25,8(230)-15(400)		25,8(230)-15(400)	
Weight	Peso	Kg. / lb (US)	108 / 238		108 / 238		118 / 261		118 / 260		123 / 277	

\* With oil pump ( without oil pump Max 5' ) - \* Con pompa dell'olio (Senza pompa olio Max 5')

\*\* Filling rate for 10 liters cylinder capacity from 0 to 200 bar ±5% - \*\* Tempi di carica per una bombola di Litri 10 da 0 a 200 bar ±5%

\*\*\* Standard filtration system (new dimension 2012) - \*\*\* Sistema filtrante standard (nuova dimensione 2012)



## A.4. Parker ST708 nitrogen membrane

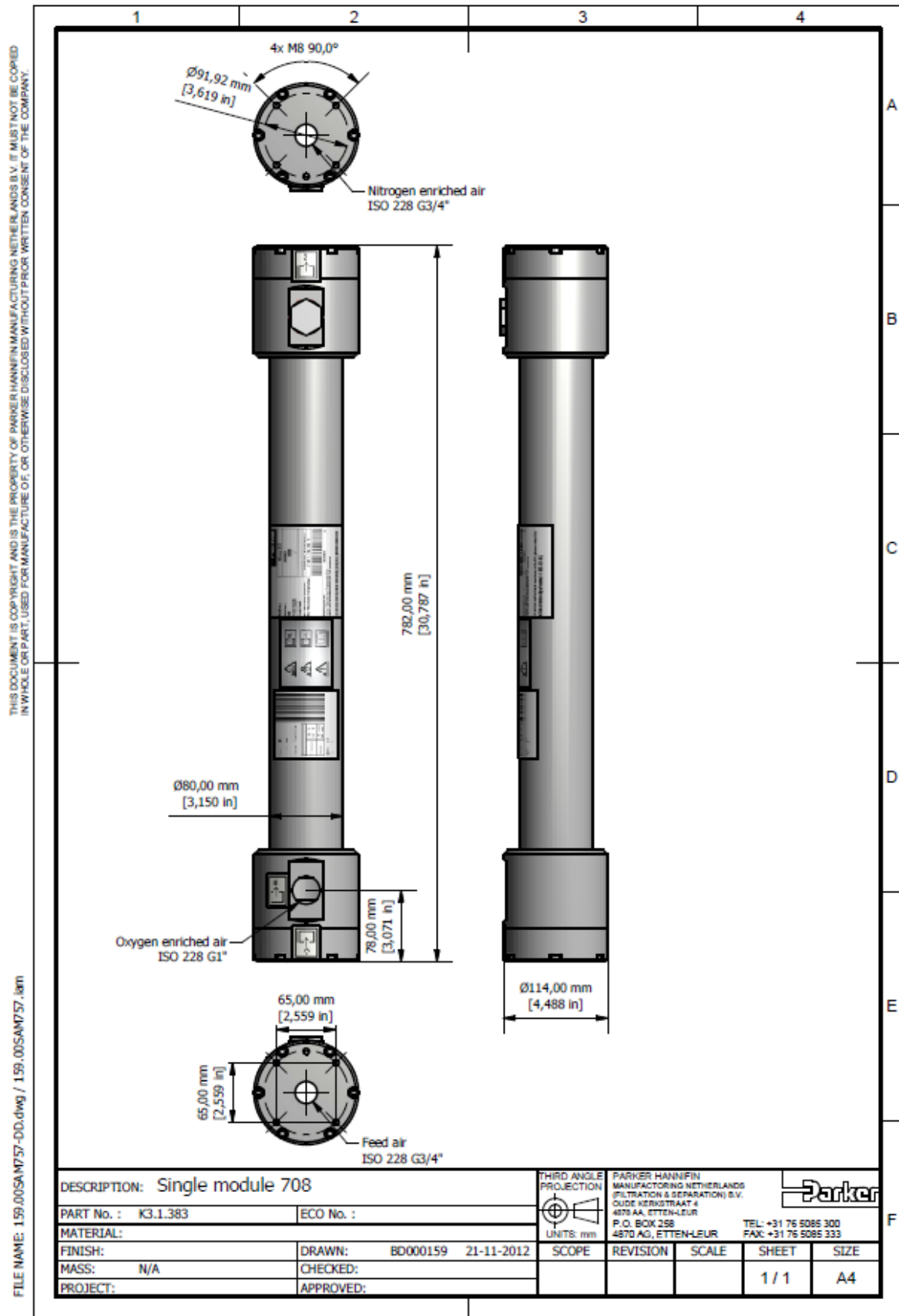

## A.5. Air purification filters from Parker

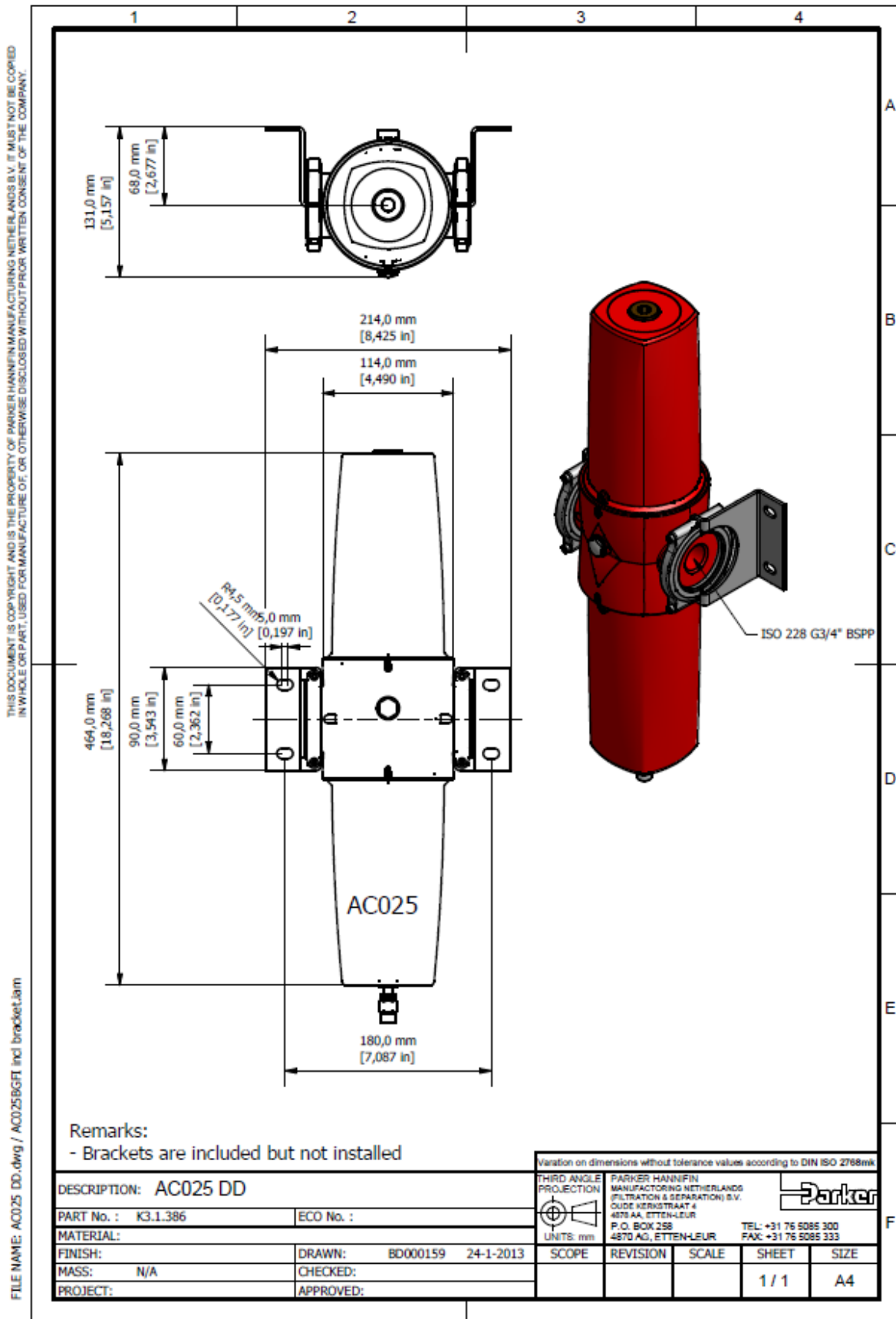

## WS020EBFX



### Download 3D Model

IGS  
IPT  
STP  
Click to launch CAD view  
Download CAD Viewer

### Buy Product

Where to Buy

DESCRIPTION	VALUE
PRODUCT TYPE	FILTER COMPRESSED AIR AND GAS
PORT/CONNECTION	Alternate BSPP: WS020EGFX
FLOW RATE	This product must be sized to match site conditions. Please refer to product literature or division.
FILTER RATING	
PRESSURE RATING	1 - 16 Barg
HOUSING MATERIAL	Aluminium (Pressure Die-Cast)
ADDITIONAL DETAIL	
SYNONYM	WS020EBFX
TRADE/BRAND NAME	Parker dh FNS
CONFIGURATOR	NO
CAD DRAWING AVAILABLE	YES

## AO025EBFX



DESCRIPTION	ATTRIBUTE VALUE
PRODUCT TYPE	FILTER COMPRESSED AIR AND GAS
PORT/CONNECTION	Alternate BSPP: AO025EGFX
FLOW RATE	This product must be sized to match site conditions. Please refer to product literature or division.
FILTER RATING	1 Micron
PRESSURE RATING	1 - 16 Barg
HOUSING MATERIAL	Aluminium (Pressure Die-Cast)
ADDITIONAL DETAIL	
SYNONYM	AO025EBFX
TRADE/BRAND NAME	Parker dh FNS

## AC025EBFI



DESCRIPTION	ATTRIBUTE VALUE
PRODUCT TYPE	FILTER COMPRESSED AIR AND GAS
PORT/CONNECTION	Alternate BSPP: AC025EGFI
FLOW RATE	This product must be sized to match site conditions. Please refer to product literature or division.
FILTER RATING	0.003 mg/m3 @ 21°C
PRESSURE RATING	1 - 16 Barg
HOUSING MATERIAL	Aluminium (Pressure Die-Cast)
ADDITIONAL DETAIL	
SYNONYM	AC025EBFI
TRADE/BRAND NAME	Parker dh FNS

## A.6. Gunnebo Artic shackle grade 8

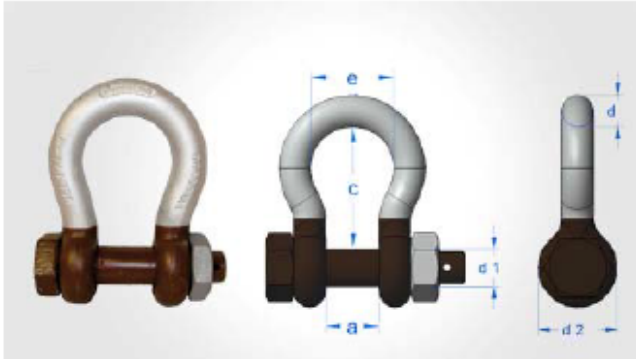

### Gunnebo Lifting Arctic Shackles No 856

Bow shackles with safety bolt

Standard:	U.S. Fed. Spec. RR.C-271/EN - 13889 DNV Type Approval No. S-5661 WLL 2.0 - 25T
Material:	Special Alloy Steel, quenched and tempered
Finish:	All parts hot dip galvanized + brown colour marking
Documentation:	Test certificate and traceable 3.1 certificate of the bow and the bolt in finished condition.
Temperature:	-40°C - 200°C

[Link to CAD files](#)

Dimension in mm.

#### Detailed information

Part no	WLL t	d	d1	a	c	d2	e	Weight kgs
A085613	2.0	1/2" - 13	16	21	47	33	33	0.42
A085616	3.25	5/8" - 16	19	27	60	40	42	0.74
A085619	4.75	3/4" - 19	22	31	71	47	51	1.18
A085622	6.5	7/8" - 22	25	37	84	50	58	1.734
A085625	8.5	1" - 25	28	43	95	58	68	2.58
A085628	9.5	1.1/8" - 28	32	46	108	64	74	3.66
A085632	12.0	1.1/4" - 32	35	52	119	72	83	5
A085635	13.5	1.3/8" - 35	38	57	132	74	89	6.05
A085638	17.0	1.1/2" - 38	42	60	146	84	98	8.12
A085645	25.0	1.3/4" - 45	50	74	178	105	127	14
A085652	35.0 *	2" - 50	57	83	197	127	138	20
A085664	55.0 *	2.1/2" - 65	70	105	255	152	185	41

## A.7. Lifting padeye drawings

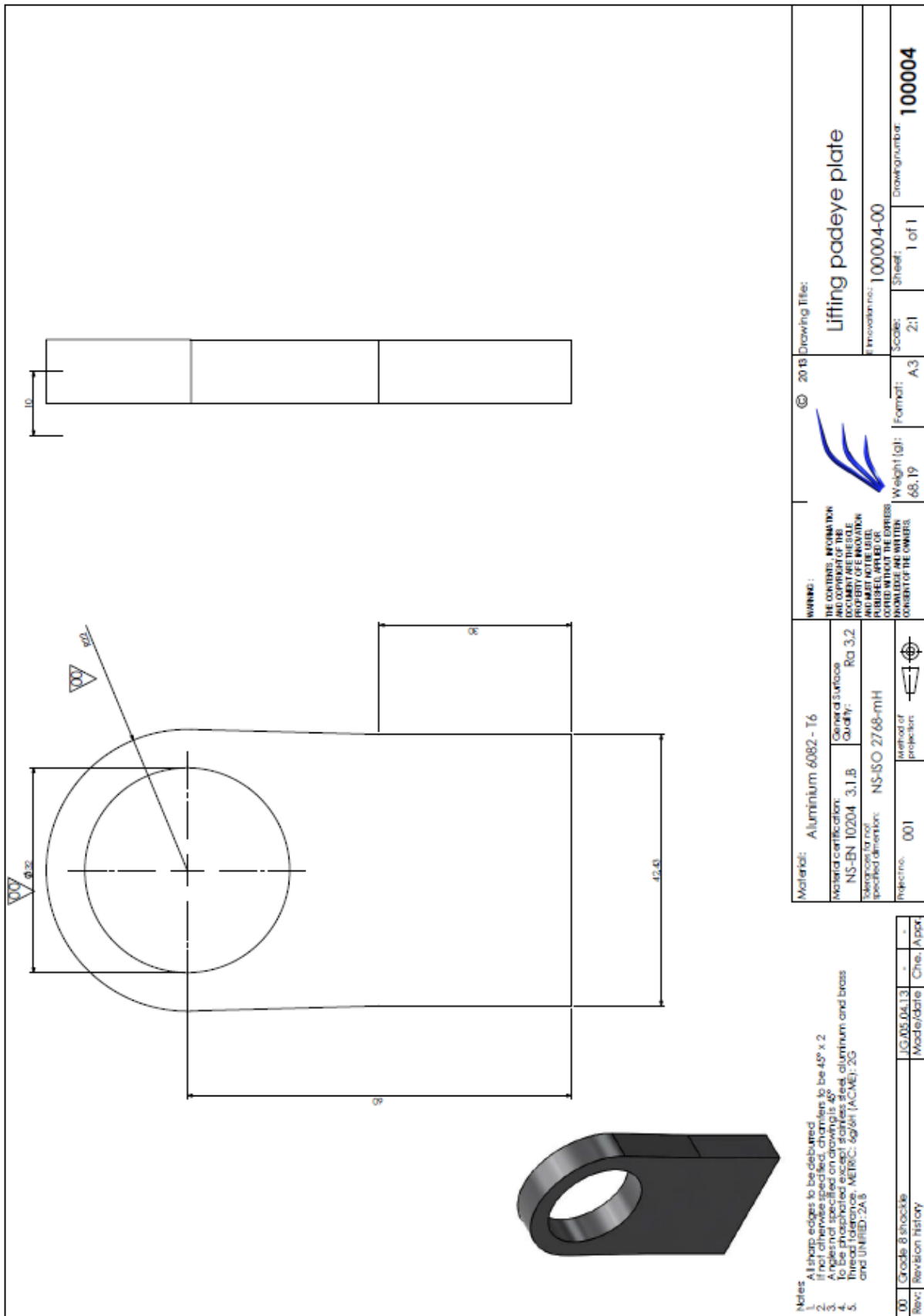

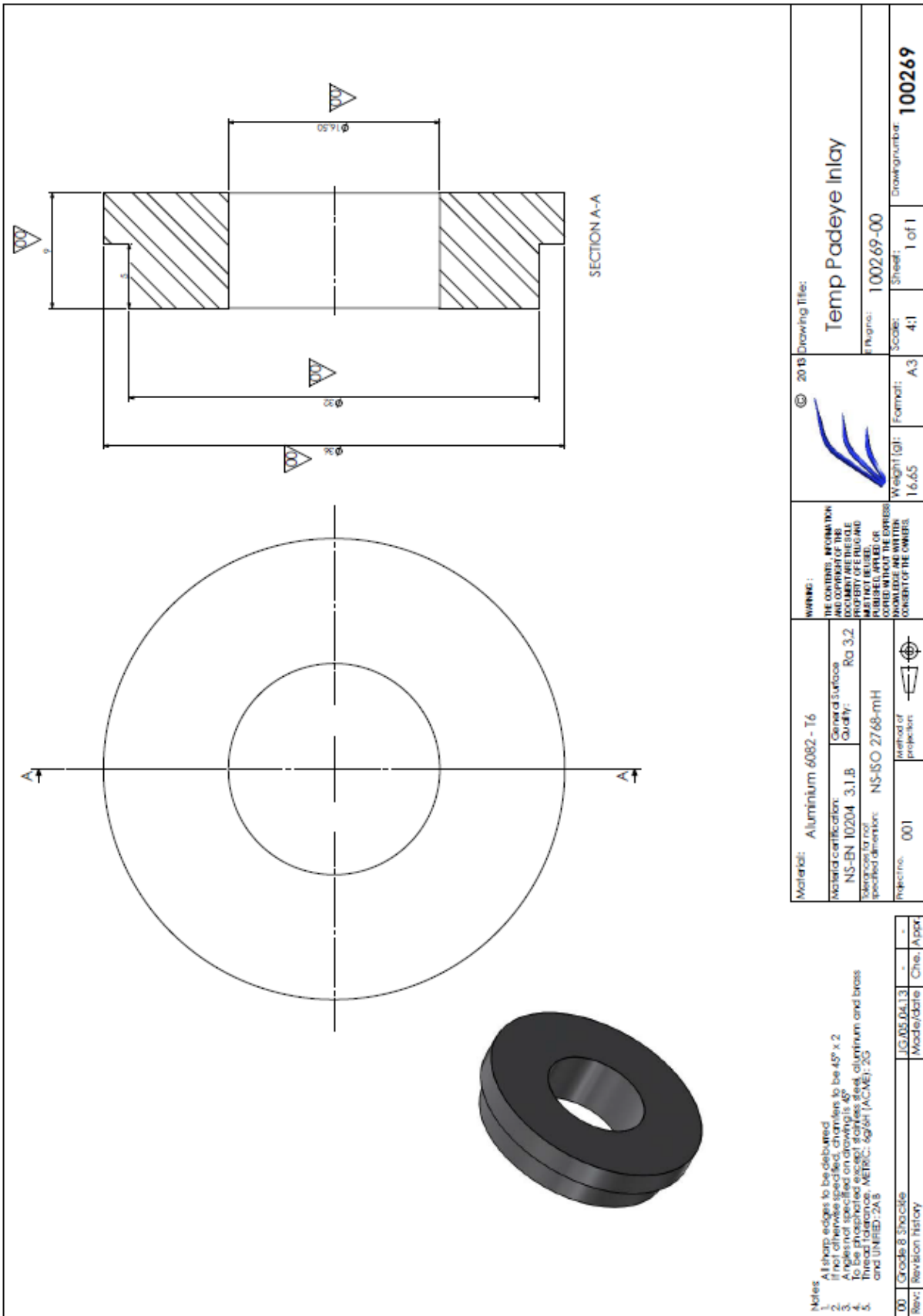

**Notes**

- All sharp edges to be deburred
- If not otherwise specified, chamfers to be 45° x 2
- Angles not specified on drawing to be 45°
- Threads to conform to ISO METRIC SYSTEM (ACME) 2B and UNIFIED 2A B
- Grade 8 Steel

**Warnings:**  
 THE CONTENTS, INFORMATION AND OPINIONS OF THIS DOCUMENT ARE THE SOLE PROPERTY OF THE ISSUING AUTHORITY AND ARE NOT TO BE REPRODUCED, COPIED OR PUBLISHED WITHOUT THE EXPRESS KNOWLEDGE AND WRITTEN CONSENT OF THE COMMAND.

**Materials:** Aluminium 6082 - T6

**Material certification:** NS-BN 10204 3.1.B  
 General surface quality: Ra 3.2  
 Surface finish for non-specified dimension: NS-ISO 2768-mH

**Project no.:** 001

**Method of projection:**

**© 2015 Drawing Title:** Temp Padeye Inlay

**Figura:** 100269-00

**Scale:** 4:1

**Sheet:** 1 of 1

**Drawing number:** 100269

**Weight (kg):** 1.665

**Format:** A3

# A.8. Main drawings for Frame 200013

ITEM NO.	PART NUMBER	REV.	DESCRIPTION	QTY.
1	100197nitro	01	Bottom Side Rail Long	2
2	100002nitro	01	Bottom End Rail	4
3	200002nitro	03	Corner Post Welded	1
4	200003nitro	03	Corner Post 2 Welded	1
5	100009nitro	02	Corner Post Short	2
6	100001nitro	01	Bottom Side Rail Long	2
7	100198nitro	03	Bottom Side Rail Short	2
8	200004nitro	03	Corner Post Medium Welded	1
9	200005nitro	01	Corner Post Medium 2 Welded	1
10	100015nitro	01	Top Side Rail	2
11	100016nitro	01	Top End Rail	2
12	100010nitro	02	Bottom Side Rail Short	2
13	100017nitro	01	Internal Main Member	2
14	100019nitro	01	Bottom Cross Member	2
15	100021nitro	02	Torpedo Beam	1
16	100022nitro	01	Torpedo Beam 2	1
17	100023nitro	01	Torpedo Cross	1
18	100092nitro	01	Filter Holder Member	1
19	100029nitro	01	Side Rest Beam	1
20	100030nitro	00	Stability Beam Short	1
21	100116nitro	00	Temp Padeye Inlay	1
22	100269nitro	00	Temp Padeye Inlay	8

© 2013 Drawing Title: Primary Structure  
 E-Part no.: 200012NMG-01  
 Drawing number: 200012NMG

Scale: 1:6  
 Sheet: 1 of 7

Weight (kg): 18.77  
 Format: A3

Project no.: 001  
 Projection method: 1st angle

JG/12.05.13  
 Made/date Che, Appt.

01 | Frame for prototype  
 Rev: Revision history

WARNING: THE CONTENTS, INFORMATION AND COPYRIGHT OF THIS DRAWING ARE THE PROPERTY OF PULS AND MUST NOT BE USED, PUBLISHED, APPLIED OR COPIED WITHOUT THE EXPRESS CONSENT OF THE OWNERS.



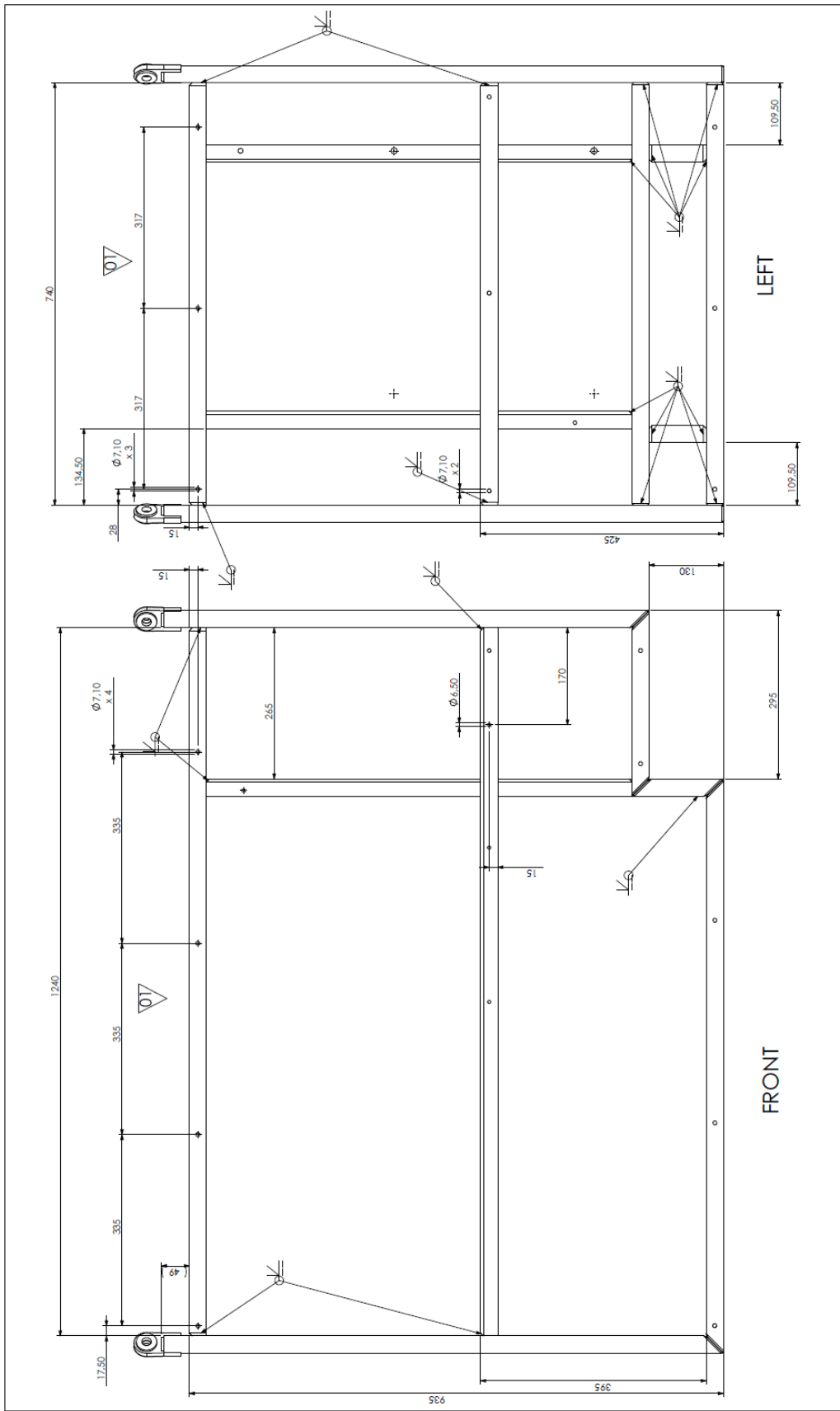

<p>© 2013 Drawing Title: <b>Primary Structure</b></p>		<p>E-Plug no.: 200012NMG-01</p>		<p>Drawing number: <b>200012NMG</b></p>	
<p>Weight (kg): 18.77</p>		<p>Scale: 1:6</p>		<p>Sheet: 2 of 7</p>	
<p>Project no. 001</p>		<p>Format: A3</p>		<p>Projection method: </p>	
<p>Project no. 001</p>		<p>Project no. 001</p>		<p>Project no. 001</p>	
<p>01 Frame for prototype</p>		<p>JG/12.05.13</p>		<p>-</p>	
<p>Rev: Revision history</p>		<p>Made/date</p>		<p>Che, Appl.</p>	
<p>WARNING: THE CONTENTS, INFORMATION AND COPYRIGHT OF THIS DRAWING ARE THE SOLE PROPERTY OF EPLUG AND MUST NOT BE USED, PUBLISHED, APPLIED OR COPIED WITHOUT THE EXPRESS CONSENT OF THE OWNERS.</p>		<p>© 2013</p>		<p>© 2013</p>	

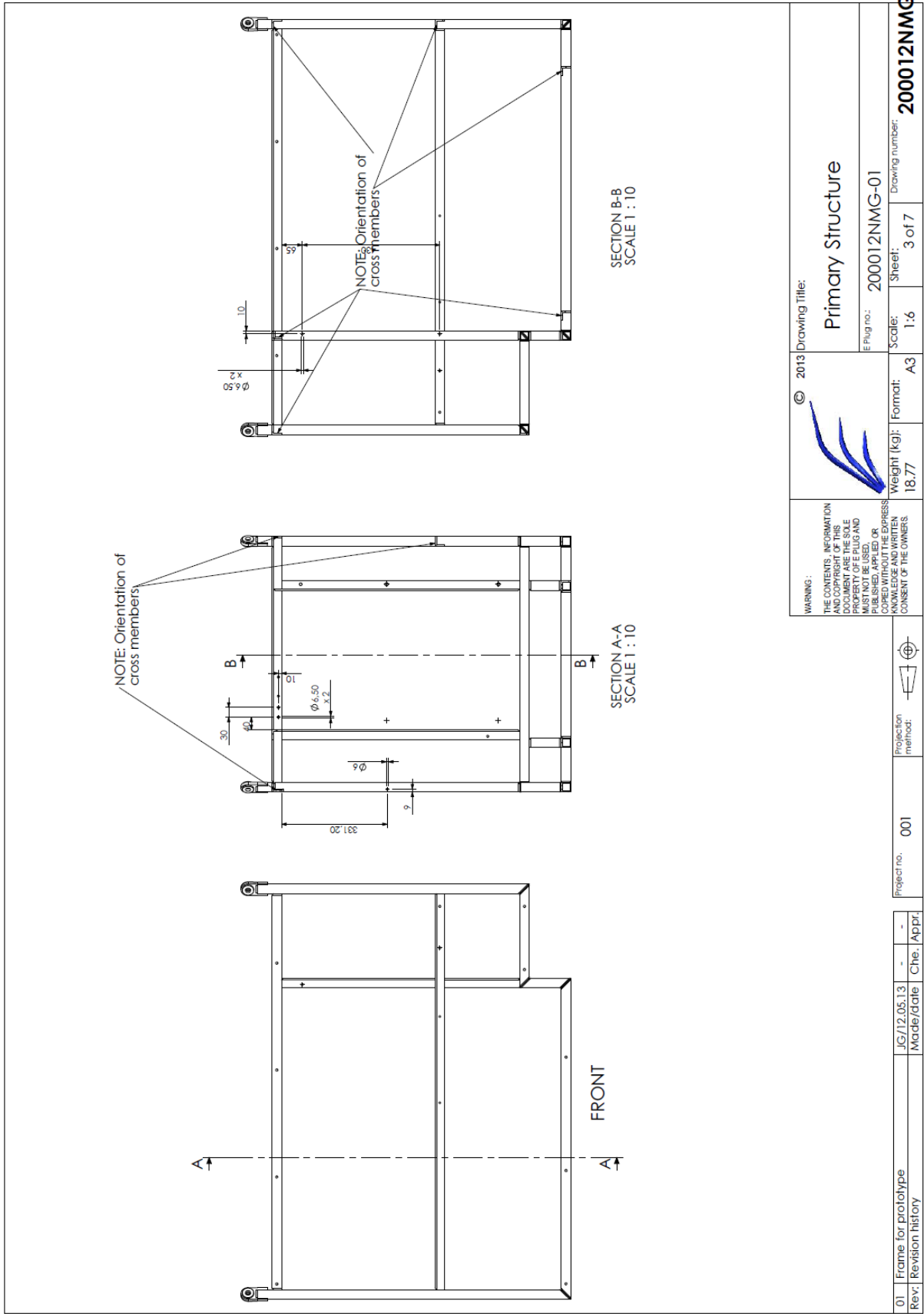

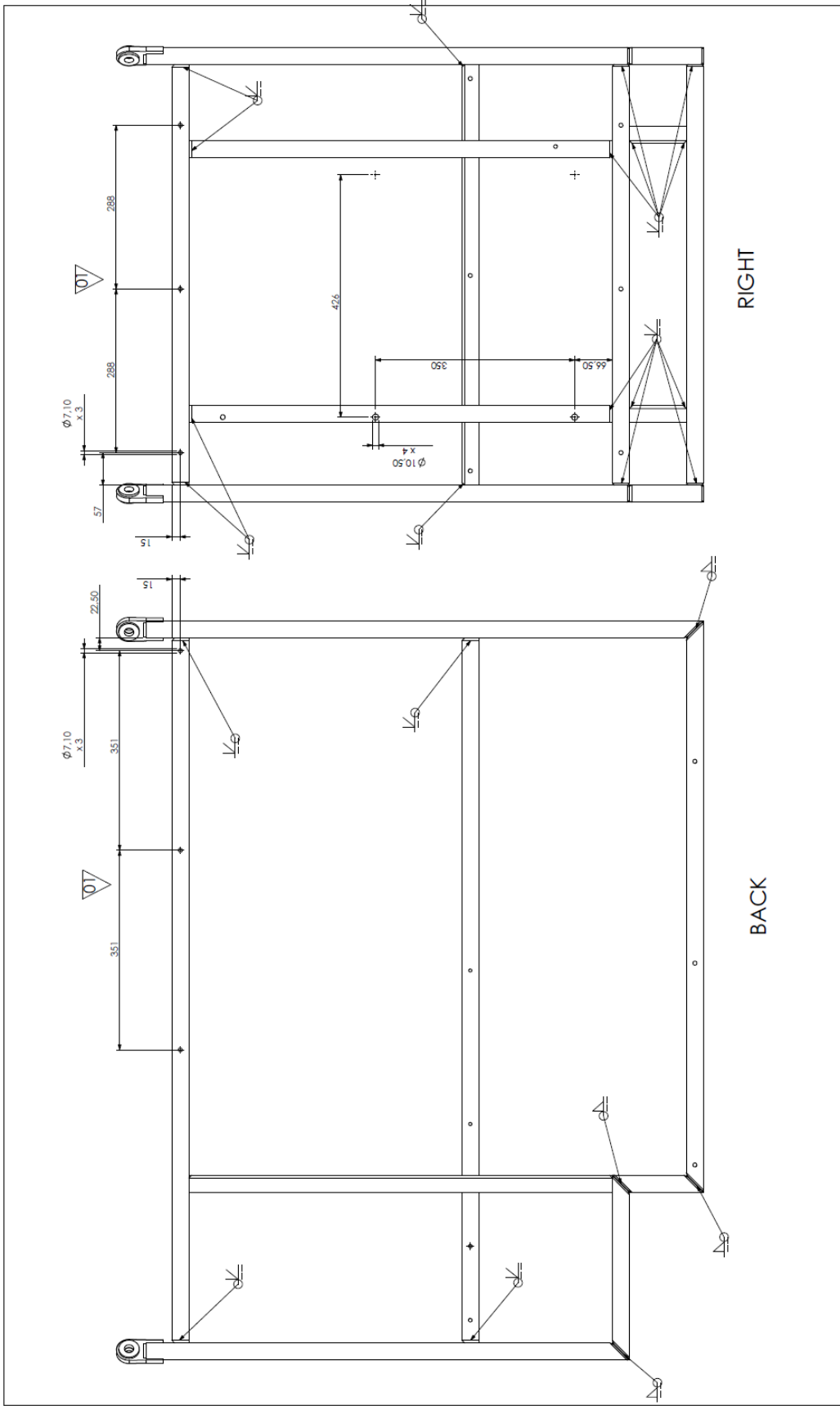

WARNING:  
THE CONTENTS, INFORMATION AND COPYRIGHT OF THIS DOCUMENT ARE THE SOLE PROPERTY OF THE COMPANY. ANY REPRODUCTION, DISTRIBUTION, PUBLISHED, APPLIED OR COPIED WITHOUT THE EXPRESS KNOWLEDGE AND WRITTEN CONSENT OF THE OWNERS.

© 2013 Drawing Title:  
**Primary Structure**

E-Part no.: 200012NMG-01

Weight (kg): 18.77

Scale: 1:6

Sheet: 4 of 7

Drawing number: **200012NMG**

Project no. 001	Projection method:	Format: A3
IC/12.05.13	Project no. 001	Format: A3
Made/date	Project no. 001	Format: A3
Che. Appr.	Project no. 001	Format: A3
01   Frame for prototype	Project no. 001	Format: A3
Rev:   Revision history	Project no. 001	Format: A3

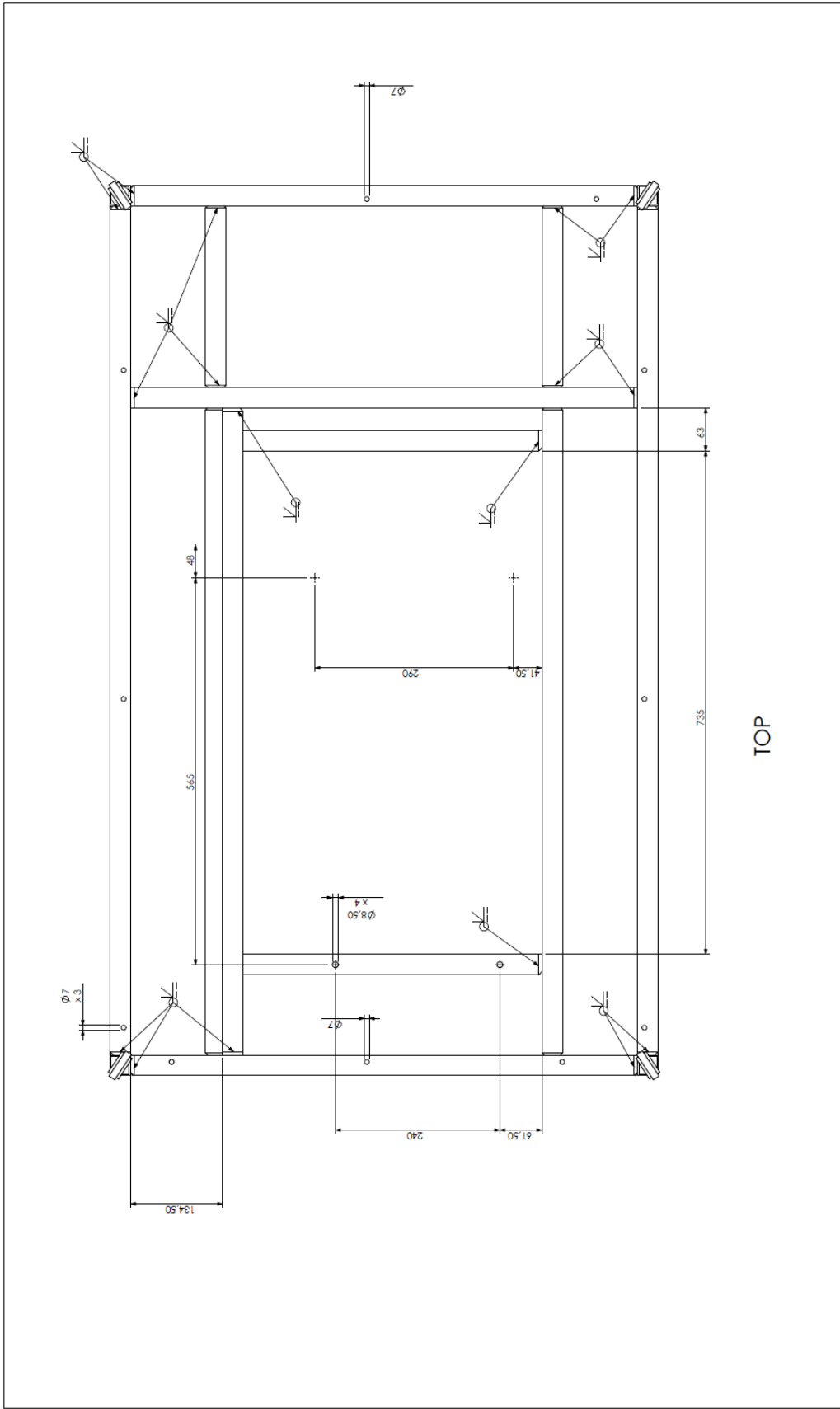

TOP

<p>WARNING: THE CONTENTS, INFORMATION AND COPYRIGHT OF THIS DRAWING ARE THE SOLE PROPERTY OF EPLUG AND MUST NOT BE USED, PUBLISHED, APPLIED OR COPIED WITHOUT THE EXPRESS CONSENT OF THE OWNERS.</p>		<p>© 2013 Drawing Title: <b>Primary Structure</b></p>	
<p>E Plug no.: 200012NMG-01</p>		<p>Drawing number: <b>200012NMG</b></p>	
<p>Weight (kg): 18.77</p>		<p>Scale: 1:6</p>	
<p>Project no. 001</p>		<p>Sheet: 5 of 7</p>	
<p>Projection method: </p>		<p>Format: A3</p>	
<p>Made/date: JG/12.05.13</p>		<p>Form: 18.77</p>	
<p>Rev: Revision history</p>		<p>Project no. 001</p>	
<p>01 Frame for prototype</p>		<p>Project no. 001</p>	
<p>Rev: Revision history</p>		<p>Project no. 001</p>	

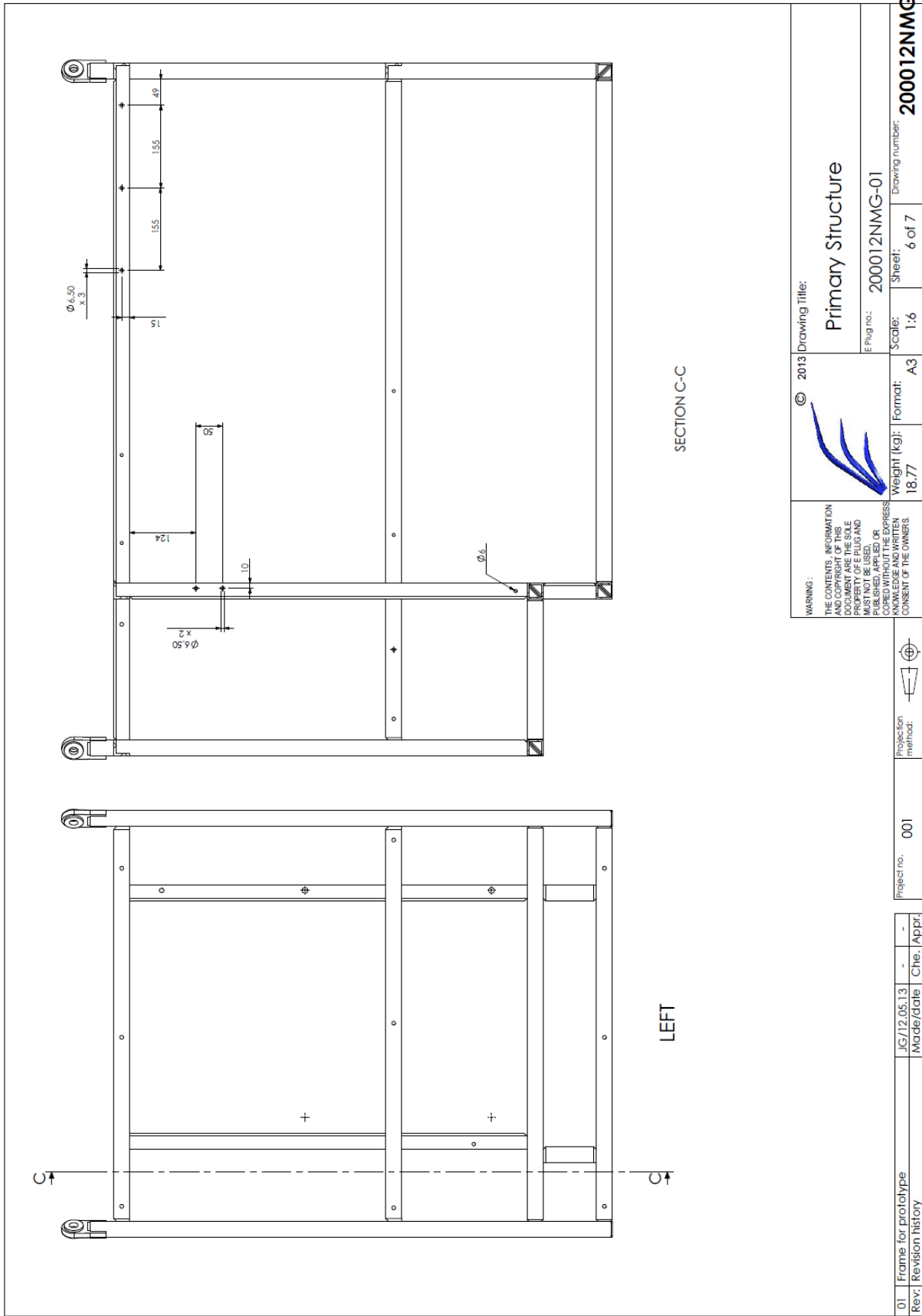

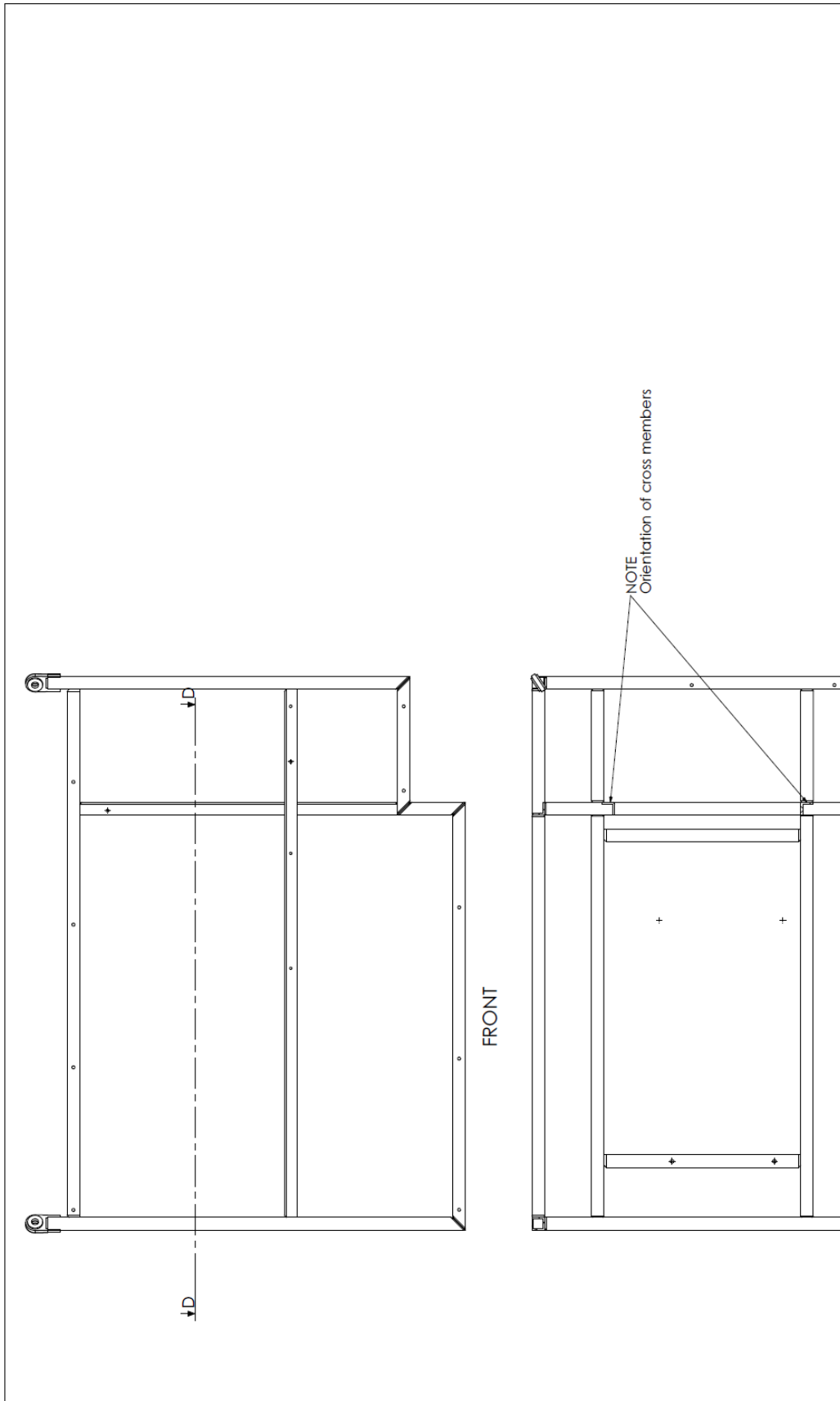

© 2013 Drawing Title: Primary Structure

Weight (kg): 18.77

Format: A3

Scale: 1:6

Sheet: 7 of 7

Drawing number: 200012NMG

Fig.no: 200012NMG-01

WARNING: THE CONTENTS, INFORMATION AND COPYRIGHT OF THIS DOCUMENT ARE THE SOLE PROPERTY OF THE COMPANY AND MUST NOT BE USED, REPRODUCED, COPIED, APPLIED, OR PUBLISHED WITHOUT THE EXPRESS KNOWLEDGE AND WRITTEN CONSENT OF THE OWNERS.

SECTION D-D  
SCALE 1 : 8

Project no. 001

Projection method:

Rev.	Frame for prototype	IG/12.05.13	-	-	Che.	Appr.
01	Revision history	Made/date				

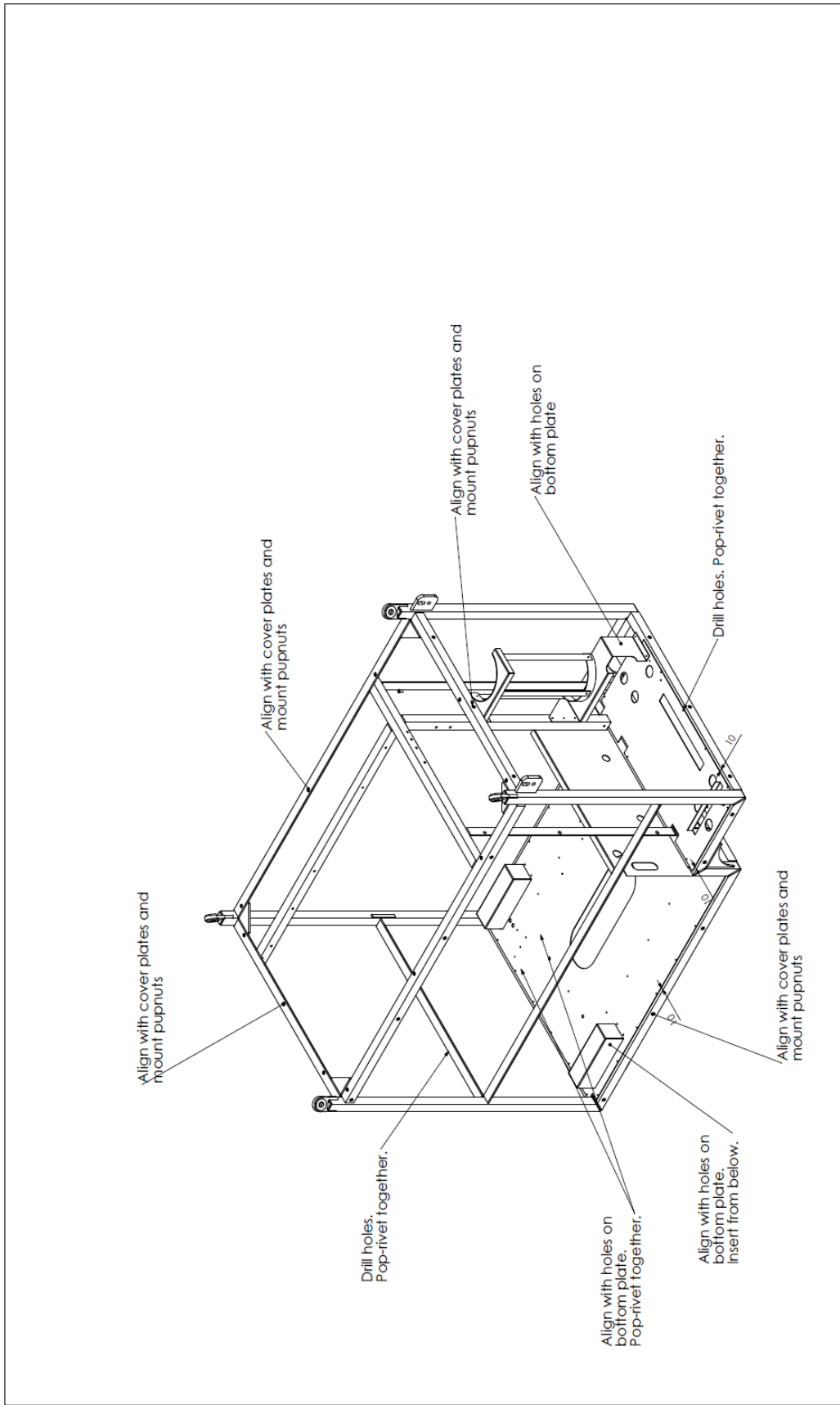

<p>WARNING:</p> <p>THE CONTENTS, INFORMATION AND COPYRIGHT OF THIS DOCUMENT ARE THE SOLE PROPERTY OF EPLUG AND SHALL BE KEPT UNPUBLISHED, APPLIED OR COPIED WITHOUT THE EXPRESS KNOWLEDGE AND WRITTEN CONSENT OF THE OWNERS.</p>		<p>© 2013</p>	<p>Drawing Title:</p> <p><b>Structure with Plates</b></p>
<p>Project no. 001</p>		<p>E Plug no.:</p> <p>200013NMG-00</p>	<p>Drawing number:</p> <p><b>200013NMG</b></p>
<p>00   For prototype assy</p>	<p>JG/03.05.13</p>	<p>Weight (kg):</p> <p>25.47</p>	<p>Scale:</p> <p>1:6</p>
<p>Rev:   Revision history</p>	<p>Made/date</p>	<p>Format:</p> <p>A3</p>	<p>Sheet:</p> <p>8 of 9</p>
<p>Projection method:</p>		<p>© 2013</p>	

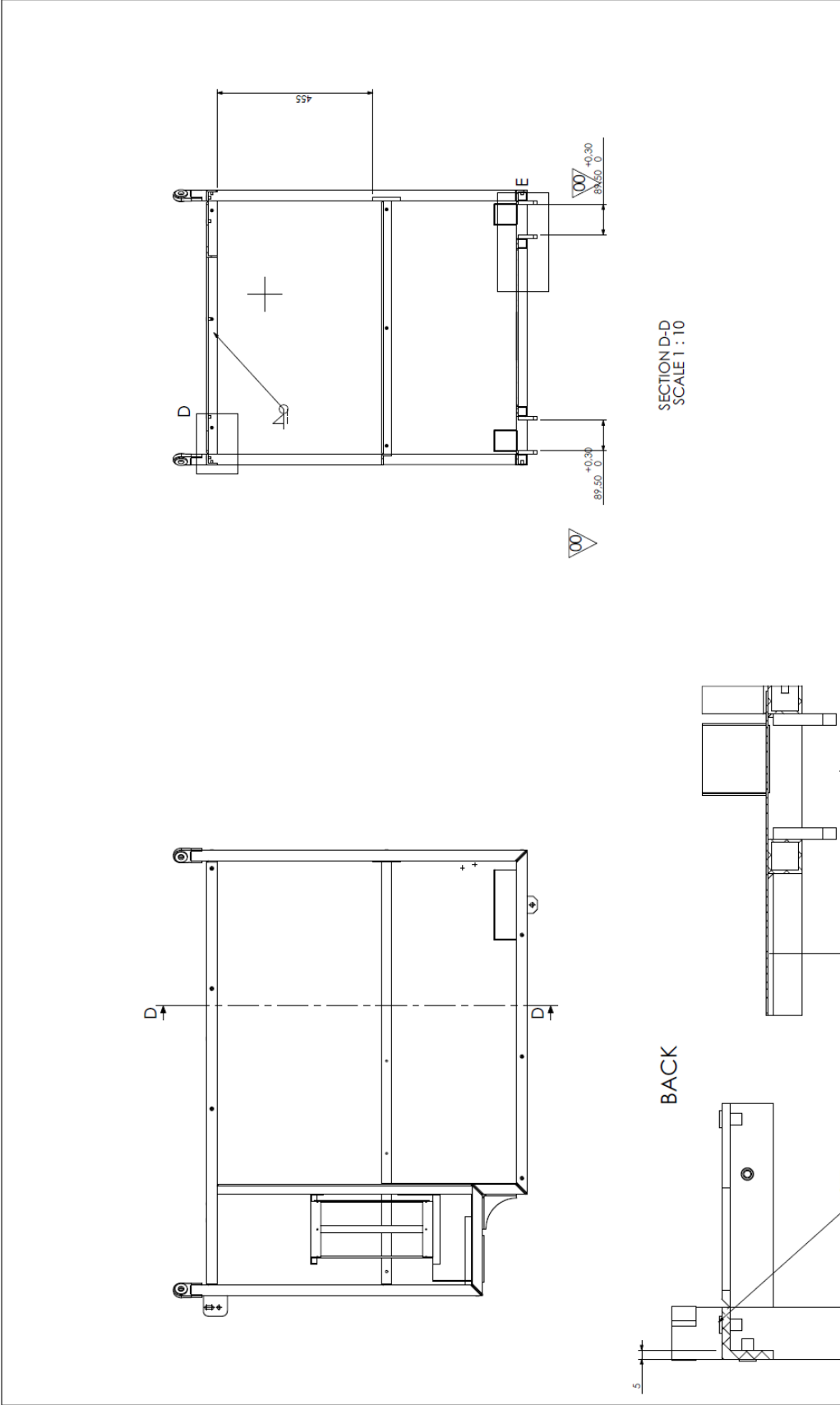

SECTION D-D  
SCALE 1 : 10

BACK

<p>WARNING :</p> <p>THE CONTENTS, INFORMATION AND COPYRIGHT OF THIS DOCUMENT ARE THE SOLE PROPERTY OF THE COMPANY. ANY REPRODUCTION, PUBLISHED, APPLIED OR COPIED WITHOUT THE EXPRESS KNOWLEDGE AND WRITTEN CONSENT OF THE OWNERS.</p>	<p>© 2013</p>	<p>Drawing Title:</p> <p><b>Structure with Plates</b></p>	<p>Drawing number:</p> <p><b>200013NMG</b></p>
	<p>E-fig.no:</p> <p>200013NMG-00</p>	<p>Scale:</p> <p>A3</p>	<p>Sheet:</p> <p>9 of 9</p>
<p>Weight (kg):</p> <p>25.47</p>	<p>Format:</p> <p>A3</p>	<p>Scale:</p> <p>1:6</p>	<p>Drawing number:</p> <p><b>200013NMG</b></p>
<p>Project no. 001</p>	<p>Projection method:</p>	<p>Project no. 001</p>	<p>Project no. 001</p>
<p>00   For prototype assy</p> <p>Rev:   Revision history</p>	<p>JG/03.05.13</p> <p>Made/date</p>	<p>-</p> <p>Che. Appl.</p>	<p>-</p> <p>Che. Appl.</p>



## A.9. Lifting calculations from excel worksheet [22]

### 4 Point Lift Calculator

Change grey cells only

Total weight?	440	kg
Distance A?	1276	mm
Distance B?	765	mm
Distance C?	638	mm
Distance D?	383	mm
Distance E?	750	mm

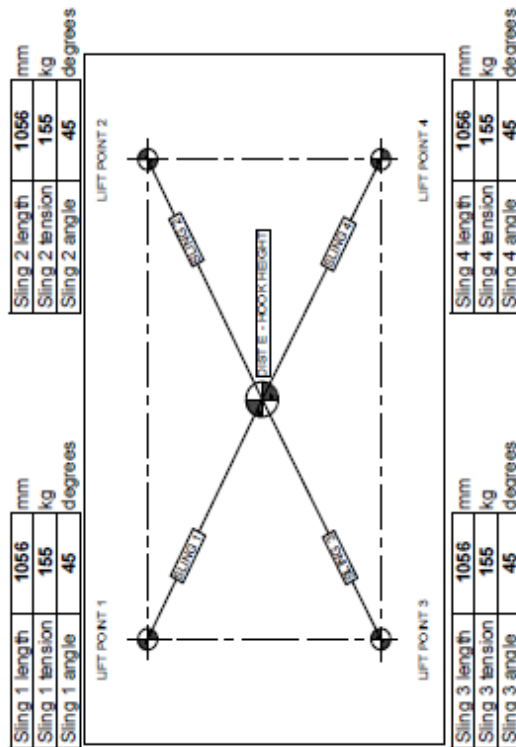
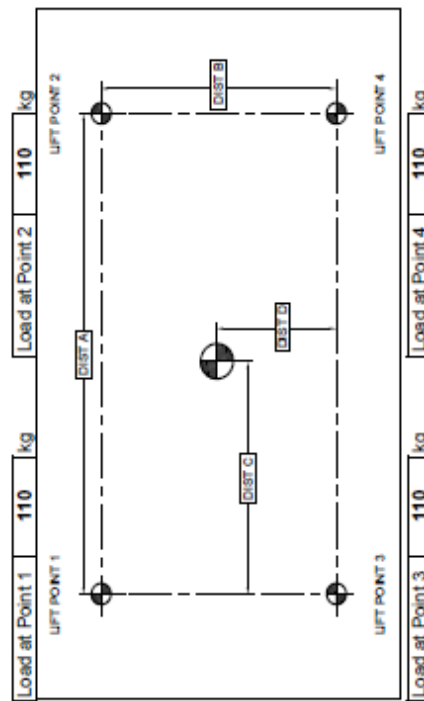

NOTE: Sling angles are from the vertical.

# A.10. Hitachi 5,5 KW scroll documentation

ORDER No.	CUSTOMER		
-----------	----------	--	--

  

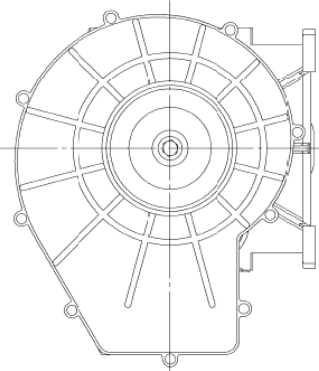

Rear View

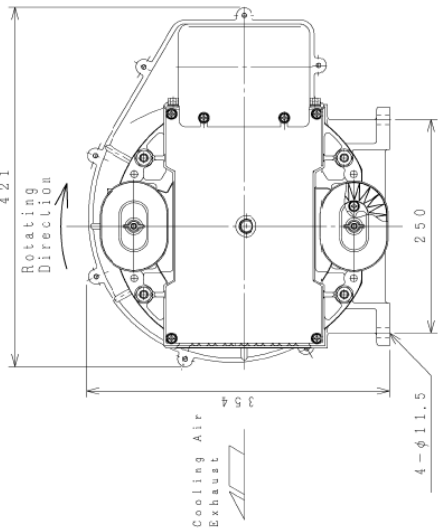

421  
Rotating Direction  
250  
354  
Cooling Air Exhaust  
4-φ11.5

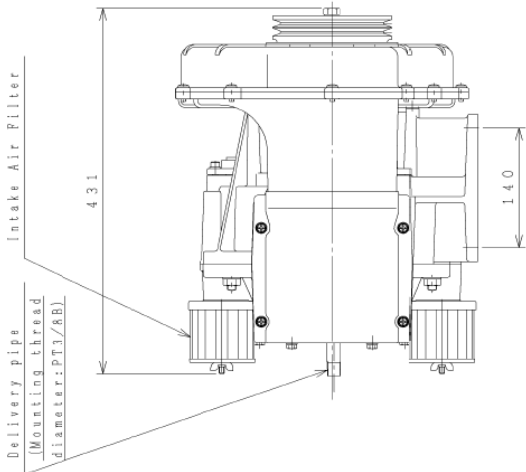

431  
140  
Delivery pipe (Mounting thread diameter: PT1/8B)  
Intake Air Filter

[Dimension in mm.]

S R L - 5 . 5 C		<b>Hitachi</b> Industrial Equipment Systems Co., Ltd.	
DRAWN	M. Urida	Dec-10-'08	SCALE
CHECKED	-	-	1 : 5
APPROVED	M. Fujihira	Dec-10-'08	3 K - 7 8 7 6

# SRL-5.5C General Specification Sheet

TBX-10031

2008.12.10

Hitachi Ltd.

## Specification

Ambient Temperature	0 — 40 °C
Ambient Humidity	30-80 % (Relative humidity)
Compressed Fluid	Air
Install Environment	Indoor
Compressed stage	Single stage
Cooling system	Air cooled

Model		SRL-5.5C		
Motor Power	kW	3.7	5.5	
Maximum Pressure	MPa(bar)	0.83(8.3)	0.83(8.3)	1.0(10)
Capacity *1	L/min	400	600	440
Revolution *2	min <sup>-1</sup> (rpm)	2200	3180	2650
V Belt type *3		3VX	3VX	3VX
Number of V Belt		1	2	2
Weight	kg	27.5		

\*1 Japanese Industrial Standard B 8341-1995 ISO1217-1986

\*2 within +/- 3%

\*3 Japanese Industrial Standard K 6368-1999

- About specifications and the shape, we may change it without prior notice.
- Secondary damages such as production and sales compensations associated with failure or defect of this product shall not be under warranty.
- V Belt is NOT included in the scope of supply.

## A.11. Primary structure component 30x30 mm square pipe catalog

KVALITET, MANGFOLD OG GODT SAMARBEID

ASTRUP AS  
Tlf.: 22 79 15 00 • Faks: 22 10 72 93  
E-post: astrup@astrup.no  
www.astrup.no

2012  
Metall-  
katalogen



\* med avrundede hjørner,  
R = 4 mm utvendig.  
Sertifikat: EN 10204 3.1 (3.1B)

### Aluminiumrør – Kvadratiske



ENAW 6060-T6 / ENAW 6082-T6

Dimensjon mm h x b x t	Lengde m	Vekt kg/m	Legering 6060	Legering 6082	Produktnr. = lagerført
18 x 18 x 1	5,0	0,19	O		001062 0100
20 x 20 x 2	5,0	0,40	O/B		001062 0110
25 x 25 x 2	5,0	0,52	O/B		001062 0120
30 x 30 x 2	6,0	0,63	O/B		001062 0135
30 x 30 x 3	6,0	0,91	O/B		001062 0134
34 x 34 x 2	5,0	0,72	O/B		001062 0140
40 x 40 x 2	6,0	0,85	O/B		001062 0149
*40 x 40 x 2,5	6,0	1,05		O/B	001062 0151
40 x 40 x 3	6,0	1,24		O/B	001062 0154
40 x 40 x 4	6,0	1,61		O/B	001062 0156
50 x 50 x 3	6,0	1,58		O/B	001062 0161
50 x 50 x 4	6,0	2,06		O/B	001062 0166
57 x 57 x 6/4	6,0	2,93		O/B	001062 0167
60 x 60 x 3	6,0	1,92		O/B	001062 01685
*60 x 60 x 4	6,0	2,45		O/B	001062 016855
80 x 80 x 4	6,0	3,41		O/B	001062 0171
80 x 80 x 5	6,0	4,20		B	001062 0175
100 x 100 x 4	6,0	4,30		O/B	001062 0181
100 x 100 x 5	6,0	5,32		B	001062 0183
100 x 100 x 12,5	6,0	12,25		B	001062 0185
120 x 120 x 5	5,0	6,44		O	001062 0186

## A.12. Datasheet for Alloy 6082-T6

### Aluminium Alloy 6082 - T6~T651



Aluminium alloy 6082 is a medium strength alloy with excellent corrosion resistance. It has the highest strength of the 6000 series alloys. Alloy 6082 is known as a structural alloy. In plate form, 6082 is the alloy most commonly used for machining. As a relatively new alloy, the higher strength of 6082 has seen it replace 6061 in many applications. The addition of a large amount of manganese controls the grain structure which in turn results in a stronger alloy. It is difficult to produce thin walled, complicated extrusion shapes in alloy 6082. The extruded surface finish is not as smooth as other similar strength alloys in the 6000 series.

In the T6 and T651 temper, alloy 6082 machines well and produces tight coils of swarf when chip breakers are used.

#### Applications

6082 is typically used in:

- ~ Highly stressed applications
- ~ Trusses
- ~ Bridges
- ~ Cranes
- ~ Transport applications
- ~ Ore skips
- ~ Beer barrels
- ~ Milk churns

#### CHEMICAL COMPOSITION

Element	% Present
Manganese (Mn)	0.40 - 1.00
Iron (Fe)	0.0 - 0.50
Magnesium (Mg)	0.60 - 1.20
Silicon (Si)	0.70 - 1.30
Copper (Cu)	0.0 - 0.10
Zinc (Zn)	0.0 - 0.20
Titanium (Ti)	0.0 - 0.10
Chromium (Cr)	0.0 - 0.25
Aluminium (Al)	Balance

#### ALLOY DESIGNATIONS

Aluminium alloy 6082 also corresponds to the following standard designations and specifications:

AA6082  
HE30  
DIN 3.2315  
EN AW-6082  
ISO: Al Si1MgMn  
A96082

#### TEMPER TYPES

The most common tempers for 6082 aluminium are:

- T6 - Solution heat treated and artificially aged
- O - Soft
- T4 - Solution heat treated and naturally aged to a substantially stable condition
- T651 - Solution heat treated, stress relieved by stretching then artificially aged

#### SUPPLIED FORMS

Alloy 6082 is typically supplied as Channel, Angle, Tee, Square bar, Square box section, Rectangular box section, Flat bar, Tube and Sheet

Plate and shate can also be supplied as 6082-T651

- Extrusions
- Bar
- Plate
- Sheet
- Tube

#### PHYSICAL PROPERTIES

Property	Value
Density	2.70 g/cm <sup>3</sup>
Melting Point	555 °C
Thermal Expansion	24 x10 <sup>-6</sup> /K
Modulus of Elasticity	70 GPa
Thermal Conductivity	180 W/m.K
Electrical Resistivity	0.038 x10 <sup>-6</sup> Ω .m

#### MECHANICAL PROPERTIES

Property	Value
Proof Stress	310 MPa
Tensile Strength	340 MPa
Elongation	11 %
Shear Strength	210 MPa
Hardness Vickers	100 HV

*Properties above are for material in the T6 / T651 condition*

#### WELDABILITY

6082 has very good weldability but strength is lowered

### A.13. P&ID on system configuration

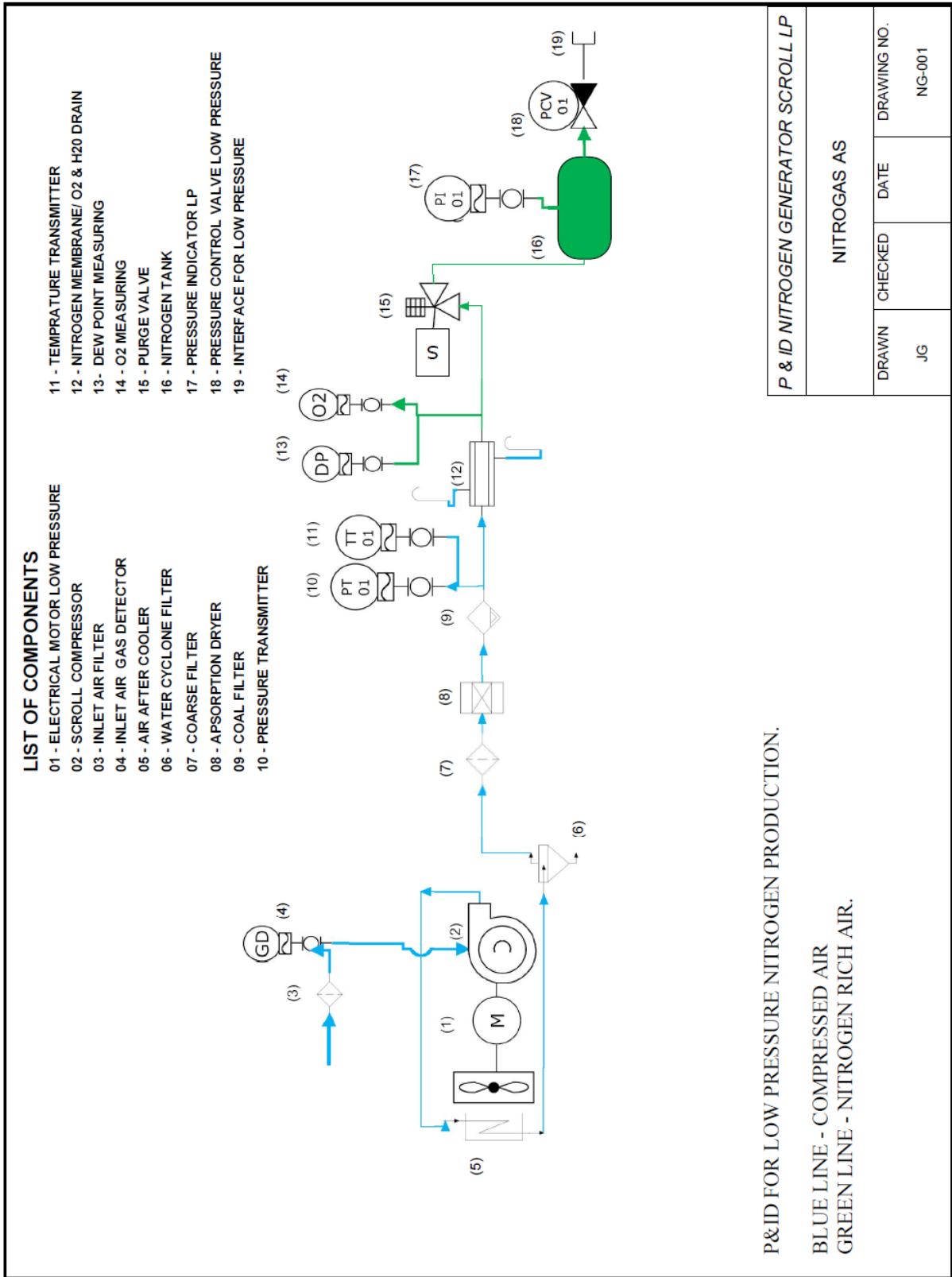

**LIST OF COMPONENTS**

- 01 - ELECTRICAL MOTOR LOW PRESSURE
- 02 - SREW COMPRESSOR
- 03 - OIL SUMPT TANK
- 04 - OIL REMOVAL FILTER
- 05 - AIR AFTER COOLER
- 06 - OIL COOLER
- 07 - WATER CYCLONE FILTER
- 08 - COARSE FILTER
- 09 - COAL FILTER
- 10 - PRESSURE TRANSMITTER
- 11 - TEMPRATURE TRANSMITTER
- 12 - NITROGEN MEMBRANE/ O2 & H2O DRAIN
- 13 - DEW POINT MEASURING
- 14 - O2 MEASURING
- 15 - PURGE VALVE
- 16 - NITROGEN TANK
- 17 - PRESSURE INDICATOR LP
- 18 - PRESSURE CONTROL VALVE LOW PRESSURE
- 19 - OPEN/CLOSED VALVE
- 20 - PRESSURE REDUCTION VALVE
- 21 - ELECTRICAL MOTOR HIGH PRESSURE
- 22 - HIGH PRESSURE COMPRESSOR
- 23 - HIGH PRESSURE FILTER
- 24 - PRESSURE INDICATOR HP
- 25 - PRESSURE CONTROL VALVE HIGH PRESSURE
- 26 - INTERFACE FOR LOW PRESSURE
- 27 - INTERFACE FOR HIGH PRESSURE
- 28 - INLET AIR FILTER
- 29 - INLET AIR GAS DETECTOR

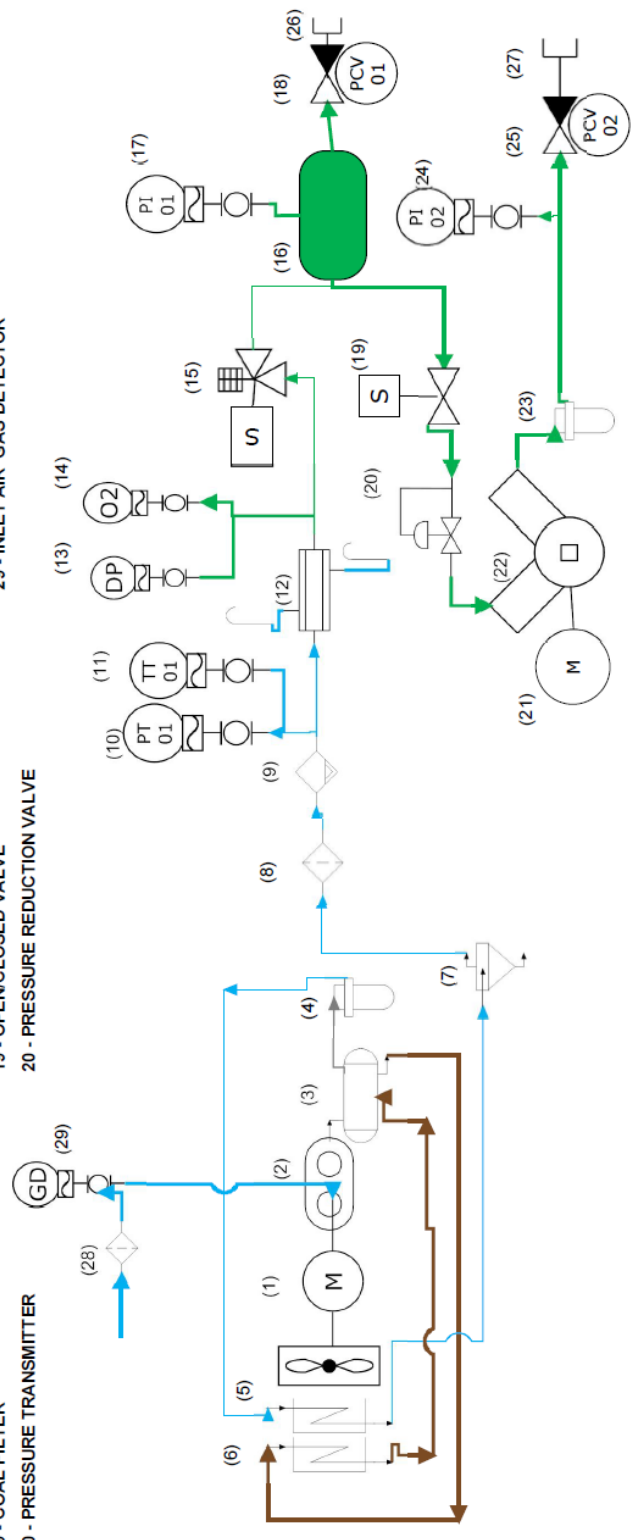

P & ID NITROGEN GENERATOR LP&HP			
NITROGAS AS			
DRAWN	CHECKED	DATE	DRAWING NO.
JG			NG-002

P&ID FOR LP & HP NITROGEN PRODUCTION.

BLUE LINE - COMPRESSED AIR  
 BROWN LINE - COMPRESSOR OIL  
 GREEN LINE - NITROGEN RICH AIR.

**LIST OF COMPONENTS**

- |                                    |  |   |
|------------------------------------|--|---|
| 01 - ELECTRICAL MOTOR LOW PRESSURE | 11 - TEMPERATURE TRANSMITTER             | 21 - ELECTRICAL MOTOR HIGH PRESSURE       |
| 02 - SREW COMPRESSOR               | 12 - NITROGEN MEMBRANE/ O2 & H2O DRAIN   | 22 - HIGH PRESSURE COMPRESSOR             |
| 03 - OIL SUMPT TANK                | 13 - DEW POINT MEASURING                 | 23 - HIGH PRESSURE FILTER                 |
| 04 - OIL REMOVAL FILTER            | 14 - O2 MEASURING                        | 24 - PRESSURE INDICATOR HP                |
| 05 - AIR AFTER COOLER              | 15 - PURGE VALVE                         | 25 - PRESSURE CONTROL VALVE HIGH PRESSURE |
| 06 - OIL COOLER                    | 16 - NITROGEN TANK                       | 26 - INTERFACE FOR LOW PRESSURE           |
| 07 - WATER CYCLONE FILTER          | 17 - PRESSURE INDICATOR LP               | 27 - INTERFACE FOR HIGH PRESSURE          |
| 08 - COARSE FILTER                 | 18 - PRESSURE CONTROL VALVE LOW PRESSURE | 28 - INLET AIR FILTER                     |
| 09 - COAL FILTER                   | 19 - OPEN/CLOSED VALVE                   | 29 - INLET AIR GAS DETECTOR               |
| 10 - PRESSURE TRANSMITTER          | 20 - PRESSURE REDUCTION VALVE            | 30 - HIGH PRESSURE BOTTLE 6 LITER         |

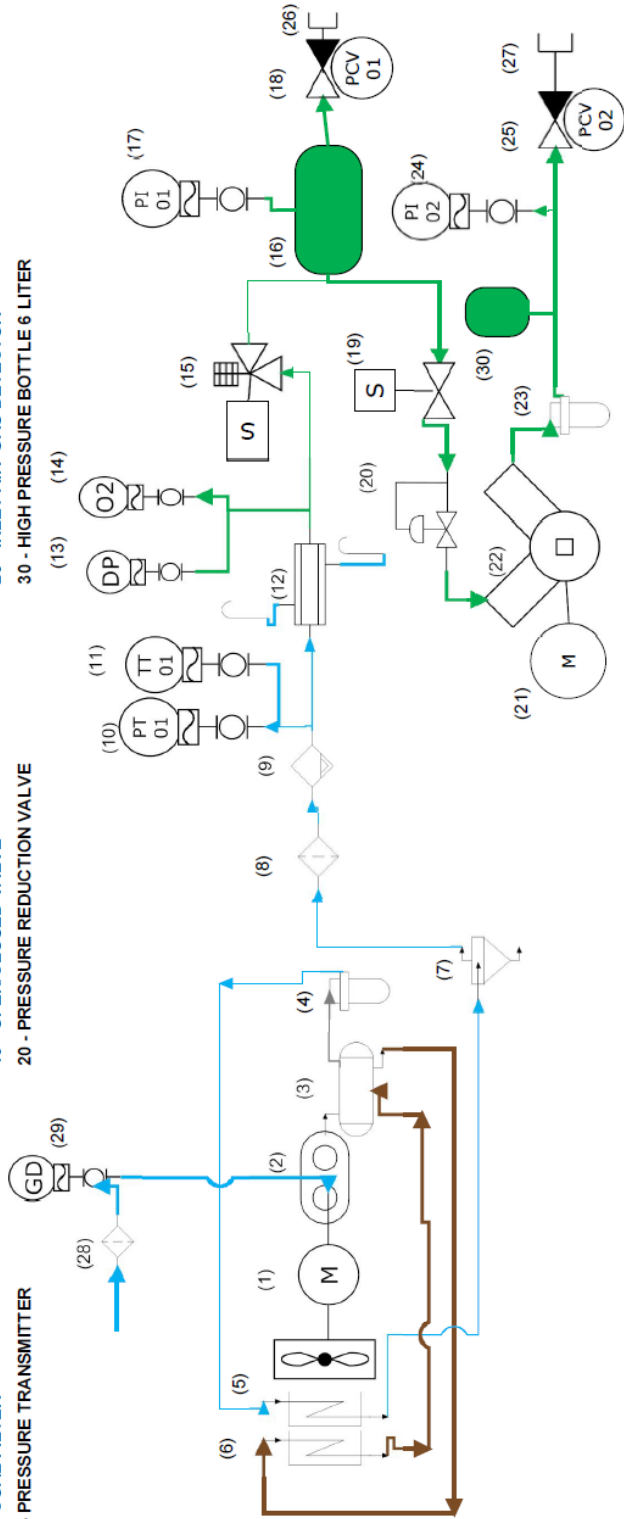

P & ID NITROGEN GENERATOR LP&HP			
NITROGEN AS			
DRAWN	CHECKED	DATE	DRAWING NO.
JG			NG-003

P&ID FOR LP & HP NITROGEN PRODUCTION.

BLUE LINE - COMPRESSED AIR  
 BROWN LINE - COMPRESSOR OIL  
 GREEN LINE - NITROGEN RICH AIR.



**LIST OF COMPONENTS**

- 01 - ELECTRICAL MOTOR LOW PRESSURE
- 02 - SREW COMPRESSOR
- 03 - OIL SUMPT TANK
- 04 - OIL REMOVAL FILTER
- 05 - AIR AFTER COOLER
- 06 - OIL COOLER
- 07 - WATER CYCLONE FILTER
- 08 - COARSE FILTER
- 09 - COAL FILTER
- 10 - PRESSURE TRANSMITTER
- 11 - TEMPRATURE TRANSMITTER
- 12 - NITROGEN MEMBRANE/ O2 & H2O DRAIN
- 13 - DEW POINT MEASURING
- 14 - O2 MEASURING
- 15 - PURGE VALVE
- 16 - NITROGEN TANK
- 17 - PRESSURE INDICATOR LP
- 18 - PRESSURE CONTROL VALVE LOW PRESSURE
- 19 - OPEN/CLOSED VALVE
- 21 - ELECTRICAL MOTOR HIGH PRESSURE
- 22 - HIGH PRESSURE COMPRESSOR
- 23 - HIGH PRESSURE FILTER
- 24 - PRESSURE INDICATOR HP
- 25 - PRESSURE CONTROL VALVE HIGH PRESSURE
- 26 - INTERFACE FOR LOW PRESSURE
- 27 - INTERFACE FOR HIGH PRESSURE
- 28 - INLET AIR FILTER
- 29 - INLET AIR GAS DETECTOR
- 30 - HIGH PRESSURE BOTTLE 6 LITER

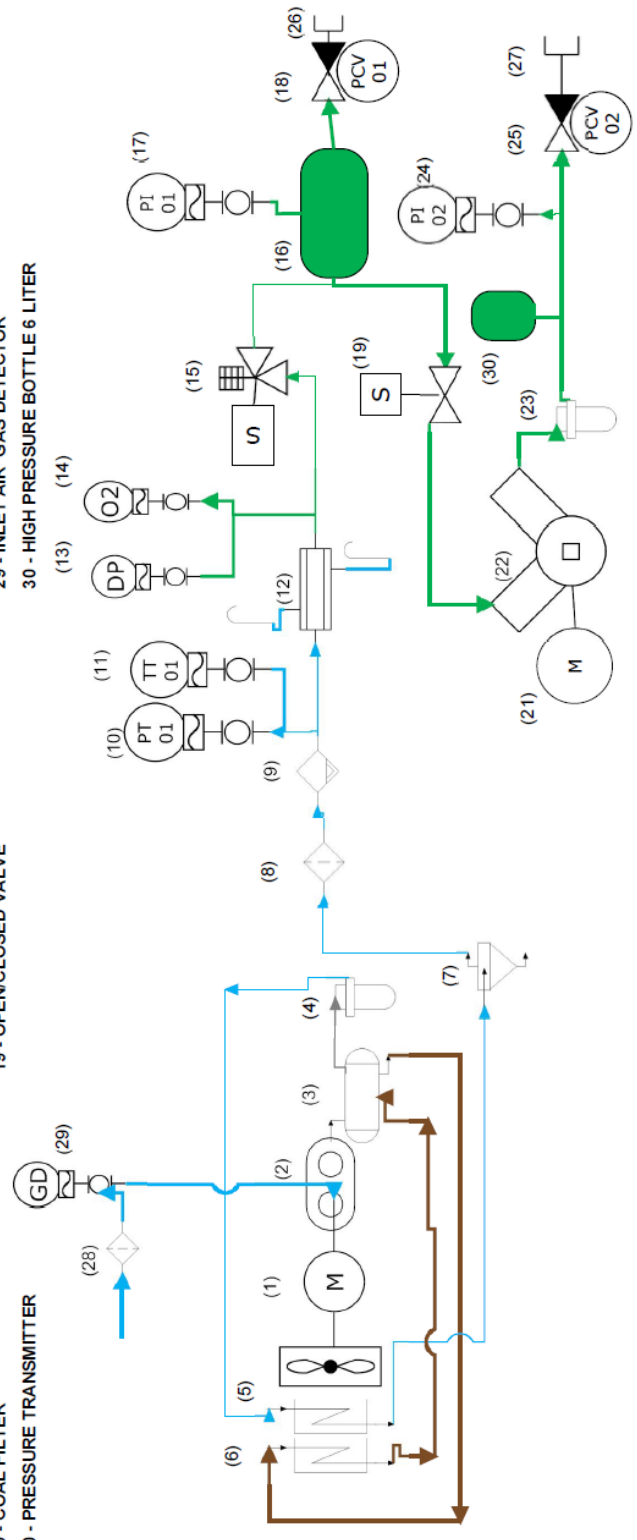

P&ID FOR LP & HP NITROGEN PRODUCTION.

BLUE LINE - COMPRESSED AIR  
 BROWN LINE - COMPRESSOR OIL  
 GREEN LINE - NITROGEN RICH AIR.

P & ID NITROGEN GENERATOR LP&HP			
NITROGAS AS			
DRAWN	CHECKED	DATE	DRAWING NO.
JG			NG-004

**LIST OF COMPONENTS**

- |   |  |   |
|---|--|---|
| 01 - ELECTRICAL MOTOR LP&HP COMPRESSORS | 11 - TEMPERATURE TRANSMITTER           | 21 - INLET AIR GAS DETECTOR               |
| 02 - SREW COMPRESSOR                    | 12 - NITROGEN MEMBRANE/ O2 & H2O DRAIN | 22 - INLET AIR FILTER                     |
| 03 - OIL SUMPT TANK                     | 13- DEW POINT MEASURING                | 23 - PRESSURE CONTROL VALVE HIGH PRESSURE |
| 04 - OIL REMOVAL FILTER                 | 14 - O2 MEASURING                      | 24 - PRESSURE INDICATOR HP                |
| 05 - AIR AFTER COOLER                   | 15 - PURGE VALVE                       | 25 - INTERFACE F FOR HIGH PRESSURE        |
| 06 - OIL COOLER                         | 16 - HIGH PRESSURE COMPRESSOR          | 26 - ELECTRICAL FAN FOR COOLING           |
| 07 - WATER CYCLONE FILTER               | 17 - PRESSURE INDICATOR LP             |   |
| 08 - COARSE FILTER                      | 18 - PRESSURE INDICATOR HP             |   |
| 09 - COAL FILTER                        | 19 - HIGH PRESSURE FILTER              |   |
| 10 - PRESSURE TRANSMITTER               | 20 -HIGH PRESSURE BOTTLE 6 LITER       |   |

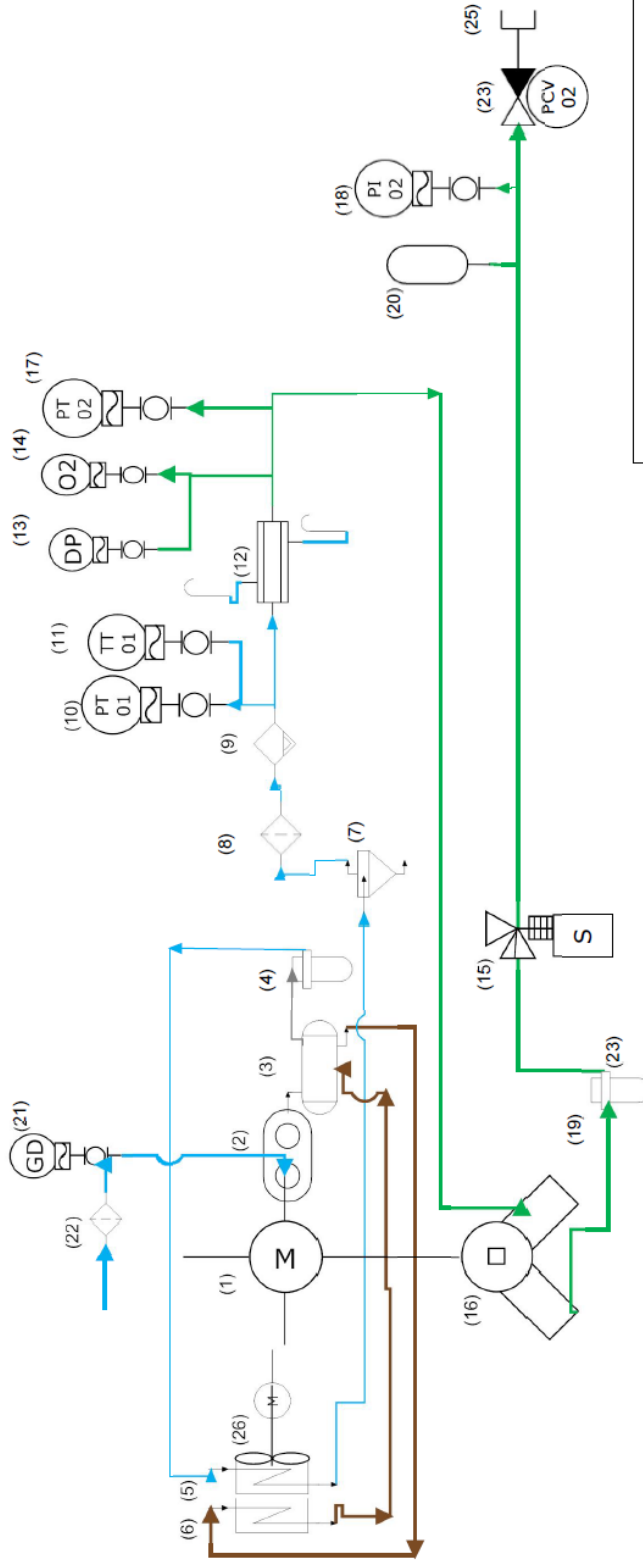

P&ID FOR HIGH PRESSURE NITROGEN PRODUCTION.

BLUE LINE - COMPRESSED AIR  
 BROWN LINE - COMPRESSOR OIL  
 GREEN LINE - NITROGEN RICH AIR.

P & ID NITROGEN GENERATOR LP&HP			
NITROGEN AS			
DRAWN	CHECKED	DATE	DRAWING NO.
JG			NG-005