



**Faculty of Science and Technology**

## **MASTER'S THESIS**

Study program/ Specialization:  <b>MASTER PROGRAMME IN PETROLEUM ENGINEERING WITH MENTION IN RESERVOIR ENGINEERING</b>	Spring semester, 2011  <b>Open / Restricted access</b>
Writer: <b>SILVIO CRIOLLO CASTILLO</b>	..... (Writer's signature)
Faculty supervisor: <b>SVEIN SKJÆVELAND</b>  External supervisor(s): <b>INGEBRET FJELDE</b>	
Title of thesis:  <b>WATER AND SURFACTANT FLOODING AT DIFFERENT WETTABILITY CONDITIONS</b>	
Credits (ECTS): <b>30</b>	
Key words:  <b>SURFACANT, WETTABILITY</b>	Pages: <u>77</u>  + enclosure: .....  Stavanger, <u>June 14 / 2011.</u> Date/year

## ***ABSTRACT***

In a surfactant flooding of oil reservoirs, surfactant products are added to the injected water to reduce the oil-water interfacial tension (IFT) and thereby mobilize capillary trapped oil. The theory in classic surfactant floods is based on water-wet sandstone reservoirs. It is now known that the wettability of sandstone reservoirs is often characterized as mixed-wet. The classic theory for surfactant flooding cannot be applied.

This thesis characterizes water flooding and surfactant flooding at different wettability conditions in Berea rock. Different wettability conditions (water-, oil- and mixed-wetting) are established by the chemical product Quilon L.

Three experiments will be carried out in the laboratory. In the first experiment (static), the wettability of treated and untreated minerals and crushed rock is characterized to evaluate the wettability alteration by the chemical Quilon L. Then, in the second experiment (stability test), water and surfactant flooding is performed in treated and untreated Berea core plugs to study the stability of the wettability alteration. Finally, in the third experiment, water flooding and surfactant flooding is applied at multiple rates to Berea core plugs at different wettability conditions to observe the characteristics in each type of rock.

Results obtained in these experiments show that water flooding is more effective in strongly oil-wet and mixed-wet rocks reducing remaining oil saturation to very low values or close to zero. Conversely, surfactant flooding is more effective in strongly water wet rocks due to high remaining oil saturation after water flooding. Also, capillary number in water flooding ranges from  $10^{-8}$  and  $10^{-6}$  whereas in surfactant flooding  $10^{-6}$  and  $10^{-4}$  in all cases.

## TABLE OF CONTENTS

MASTER’S THESIS.....	1
ABSTRACT.....	2
NOMENCLATURE.....	5
ACKNOWLEDGEMENTS.....	6
INTRODUCTION.....	7
LITERATURE STUDY.....	9
1.1 Wettability.....	9
1.1.1 Methods to determine wettability.....	10
1.1.1.1 Quantitative methods.....	10
i Contact-Angle method.....	10
ii Amott.....	12
iii USBM.....	14
iv Electrical Resistivity.....	15
1.1.1.2 Qualitative methods.....	16
i Flotation methods.....	17
ii Relative permeability.....	17
iii Recovery curves.....	18
1.1.2 Techniques to alter wettability.....	19
i Silanization.....	19
ii Quilon treatments.....	21
1.2 Surfactants.....	21
1.2.1 Surfactant adsorption.....	23
1.2.1.1 The electrical double layer.....	23
1.2.1.2 Adsorption at solid/liquid interfaces.....	23
1.2.1.3 Wettability alteration.....	25
1.2.1.4 Liquid/liquid interfacial adsorption and IFT reduction.....	25
1.2.2 Micelle formation and critical micelle concentration (CMC).....	25
1.2.3 Phase behavior of microemulsions.....	26
1.2.4 Surfactant flooding.....	31

1.2.4.1 Micellar/polymer process.....	31
EXPERIMENTAL PROCEDURES.....	34
2.1 Properties of fluids and solid surfaces.....	34
i. Wettability modifier.....	34
ii. Minerals.....	34
iii. Porous media.....	34
iv. Brine.....	35
v. Surfactant solution.....	35
vi. Oil.....	35
2.2 Experiments.....	36
2.2.1 Static experiments.....	36
2.2.2 Stability test.....	37
2.2.3 Water flooding and surfactant flooding experiments .....	39
RESULTS AND DISCUSSION.....	43
3.1 Rock and fluid properties.....	43
3.2 Static experiments.....	44
3.3 Stability test.....	47
3.4 Water flooding and surfactant flooding experiments .....	54
CONCLUSIONS.....	69
REFERENCES.....	71
Appendix A.....	74
Appendix B.....	76

## ***NOMENCLATURE***

IFT	=	Interfacial tension
k	=	Permeability
k <sub>abs</sub>	=	Absolute permeability
k <sub>o</sub>	=	Effective permeability to oil
k <sub>r</sub>	=	Relative permeability
k <sub>w</sub>	=	Effective permeability to water
n	=	Archie saturation exponent
N <sub>ca</sub>	=	Capillary number
PV	=	Pore volume
Q	=	Flow rate
RI	=	Resistivity index
r <sub>o</sub>	=	Electrical resistance when rock is saturated with 100% water
r <sub>t</sub>	=	Electrical resistance when rock is partially saturated with water
S <sub>oc</sub>	=	Remaining oil saturation after surfactant flooding
S <sub>ow</sub>	=	Remaining oil saturation after water flooding
S <sub>w</sub>	=	Water saturation

### Subscript

o	=	oil
w	=	water
i	=	initial

## ***ACKNOWLEDGEMENTS***

I would like to thank God who has been guiding my track through the knowledge, perseverance, patience and strength to finish this research successfully. Also, a special gratitude to my patient and lovely wife and my little baby David Alejandro who have always been supporting me during these 2 years. I want to tell them: "Thanks for being next to me and for being the most important people in my life".

In addition, thanks to my parents for being always close to me, giving me advices and trying to help me out to solve some problems although the long distances.

Finally, I want to thank Ingebret Fjelde and Kumuduni Abeysinghe, who work for IRIS, for letting me do my research in the installations, and to dedicate full time to carry out this work.

***Silvio Criollo***

***IN GOD I TRUST***

# ***INTRODUCTION***

As world oil demand continues rising, and at the same time conventional reserves deplete, secondary and tertiary processes <sup>1</sup> have been implemented in fields in order to increase the oil recovery factor in sandstone reservoirs.

In order to maintain pressure, water flooding is the most common process used as a secondary recovery <sup>1-3</sup>. In this classical method (immiscible), water is injected to displace oil toward producing wells obtaining a final oil recovery of around 35 to 50% of the original oil in place leaving some remaining oil in sandstone reservoirs. This trapped oil is related with viscous and capillary forces like oil-water interfacial tension, IFT, that is around 30 to 50 dynes/cm and capillary number,  $N_{ca}$ , which ranges from  $10^{-8}$  to  $10^{-6}$ .

Tertiary processes <sup>1,4</sup> (chemical, miscible and thermal processes) are implemented to the oil reservoirs after the secondary recovery. Chemical process (surfactant flooding) will be studied in this research. In this miscible method, surfactant products (special class of molecules with both hydrophobic and hydrophilic parts) are added to injected water in a very low concentration to 3 wt % <sup>1</sup> to reduce the oil-water interfacial tension and thereby mobilize capillary trapped oil (ganglia). IFT is usually around  $10^{-2}$  dynes/cm and capillary number ranges from  $10^{-6}$  to  $10^{-4}$  obtaining a notable reduction in oil residual saturation.

A lot of studies have been realized around classic water and surfactant flooding which are based on water-wet sandstone reservoirs <sup>5-8</sup>. It is now known that the wettability of sandstone reservoirs is often characterized as mixed-wet. Therefore, the classic theory for water and surfactant flooding cannot be applied to mixed-wet sandstone reservoirs.

The purpose of the research in this thesis is to characterize the water flooding and surfactant flooding at different wettability conditions in Berea rock. Different wettability

conditions like strong oil-wet, strong water-wet and mixed-wet are established by using a chemical product at different concentrations.

This thesis has been organized as follows: in the first part, literature study will be shown. Wettability concepts will be discussed: wetting systems, methods to measure and how to alter the wettability. Also, surfactant chemicals are introduced: types, properties, characteristics and surfactant flooding.

In the second part, procedures for three experiments that will be carried out in the laboratory will be shown. 1) In the static experiments, the wettability of treated and untreated minerals and crushed rock is characterized to evaluate the wettability alteration by the chemical Quilon L. 2) In the stability test experiment, water and surfactant flooding is performed in treated and untreated Berea core plugs to study the stability of the wettability alteration. 3) In the third experiment, water flooding and surfactant flooding is applied at multiple rates to Berea core plugs at different wettability conditions to observe the characteristics in each type of rock.

In the third part, results obtained from the three experiments will be discussed and compared with the literature study and previous work. These results will characterize (properties and remaining oil saturation reduction) the oil-, water- and mixed-wet rocks during water and surfactant flooding. Finally, in the last part, conclusions derived from the results will be analyzed.



# LITERATURE STUDY

## 1.1 Wettability

Wettability has been defined by Jerauld and Rathmell <sup>9</sup> “as a tendency of one fluid of a fluid pair to coat the surface of a solid spontaneously”. Another important definition is given by Anderson <sup>10</sup> who defines wettability as “the tendency of one fluid to spread on or adhere to a solid surface in the presence of other immiscible fluids”. Therefore, in a fluid/rock system, depending on the preference of the fluid to coat the rock surface, it can be water-wet or oil-wet system (Figure 1.1). In the first case, water has the tendency to adhere to the majority of the rock surface occupying the small pores, whereas in the second case oil is in contact with the majority of the rock surfaces occupying the small pores.

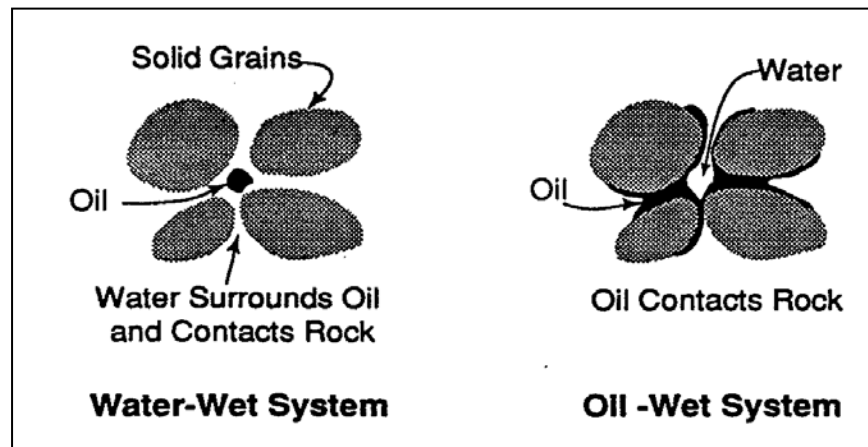

Figure 1.1 Water-wet vs. Oil-wet systems <sup>1</sup>

Depending on the interaction between fluids and rock, the systems could be classified <sup>10</sup> as a strongly water-wet or strongly oil-wet. Nevertheless, in some systems, both oil and water tends to adhere to the rock surface which is defined as intermediate (or neutral) wettability. There is also another type of wettability called “fractional” where different areas of the core have different wetting preferences. It occurs where rock surface has variable mineral composition and surface chemistry. A special type of fractional

wettability was introduced by Salathiel <sup>11</sup> “mixed-wettability” in which the smaller pores are water-wet and filled with water whereas the larger pores are oil-wet and filled with oil (it forms a continuous path). Salathiel explains this phenomenon: when oil initially invaded originally water-wet reservoir, it displaced water from the larger pores, while the smaller pores remained water-filled because of capillary forces.

### ***1.1.1 Methods to determine wettability***

A lot of methods have been developed to evaluate the wettability of a fluid/rock system. Anderson <sup>12</sup> carried out a study of the quantitative methods such as contact angles <sup>12</sup>, imbibition and forced displacement (Amott <sup>13</sup>), USBM <sup>14</sup> and electrical resistivity <sup>15</sup> wettability method, and qualitative methods <sup>12</sup> –imbibition rates, microscope examination, flotation, glass slide method, relative permeability curves, permeability/saturation relationships, capillary pressure curves, capillarimetric method, displacement capillary pressure, reservoir logs, nuclear magnetic resonance and dye adsorption.

#### ***1.1.1.1 Quantitative methods***

##### ***i. Contact-Angle Method***

The contact angle <sup>12</sup> is the best wettability measurement method when pure fluids and artificial cores are used. It is also good at examining the effects of temperature, pressure, and brine chemistry on wettability.

Many methods of contact-angle measurement have been developed, but the most common used in the petroleum industry are sessile drop method and a modified form of the sessile drop method. For the first case, it uses a single flat, polished mineral crystal (Figure 1.2), whereas in the second one it uses two flat, polished mineral crystals that are mounted parallel to each other on adjustable posts (Figure 1.3a).

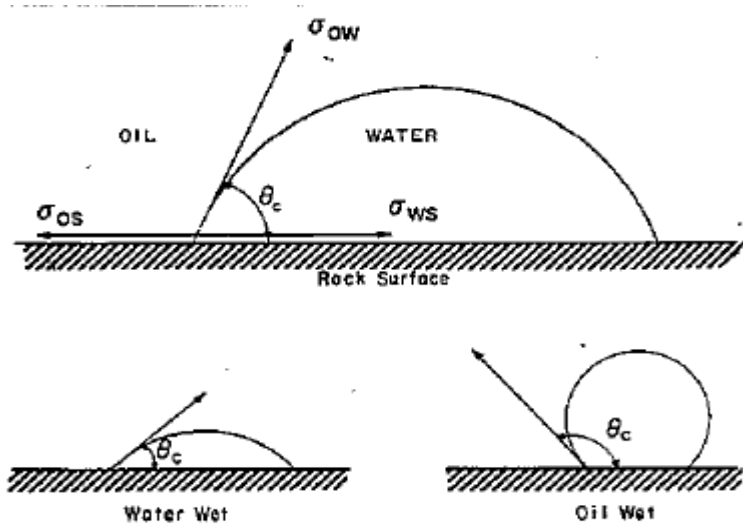

Figure 1.2 Wettability of the oil/water/rock system <sup>12</sup>

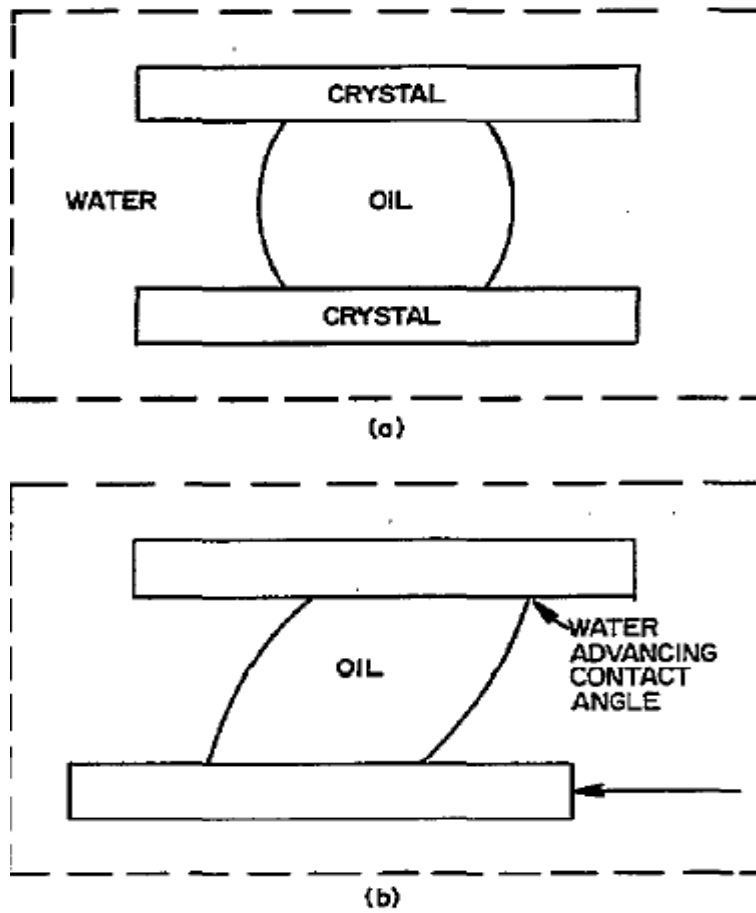

Figure 1.3 Contact-angle measurements <sup>12</sup>

For the modified sessile drop method, an oil drop is placed between the two crystals, and then it is aged for a few days. After this, the two crystals are moved parallel to each other (Figure 1.3b) getting a non-equilibrium angle which will decrease after some days until a constant contact angle is obtained.

The disadvantage of this method is the hysteresis generated between the water-advancing and water receding angles. Anderson <sup>12</sup> showed that contact-angle hysteresis can be caused by surface roughness, surface heterogeneity and surface immobility on a macromolecular scale.

*ii. Amott*

Amott <sup>13</sup> carried out a test to determine the average wettability of a core which involves imbibition and forced displacement volumes both of water by oil and oil by water. Amott's test consists of the following steps:

1. Flush core with water and with kerosene to remove most of the crude oil and formation water.
2. Remove gas by evacuating with kerosene
3. Centrifuge under brine until the residual oil saturation is obtained
4. Immerse the core in kerosene, and record the volume of water spontaneously released (imbibition) after 20 hours.
5. Centrifuge the core under kerosene until the irreducible water saturation is reached, and record the total volume of water displaced (volume displaced by spontaneous imbibition is included).
6. Immerse the core in brine, and measure the volume of oil spontaneously displaced by imbibition of water after 20 hours.
7. Centrifuge the core in brine until residual oil saturation is obtained, and record total volume of oil displaced.

The wettability of the rock according to the Amott's test is giving by 2 ratios: (1) displacement-by-oil index,  $I_o$ , ratio between water volume displaced by spontaneous oil imbibition alone,  $V_{wsp}$  and the total displaced by oil imbibition and centrifugal (forced) displacement,  $V_{wt}$

$$I_o = \frac{V_{wsp}}{V_{wt}} \quad (1.1)$$

And (2) displacement-by-water index,  $I_w$ , ratio between oil volume displaced by spontaneous water imbibition alone,  $V_{osp}$  and the total displaced by water imbibition and centrifugal (forced) displacement,  $V_{ot}$

$$I_w = \frac{V_{osp}}{V_{ot}} \quad (1.2)$$

The wettability of a rock is given by these indexes. For a strong water-wet core,  $I_w$  will be positive whereas  $I_o$  will be zero. Similarly, in a strong oil-wet core,  $I_o$  will have positive values whereas  $I_w$  will be zero. In the case of a neutral wet core, both indexes are zero.

A modification of this method called "Amott-Harvey Relative Displacement Index" is being used more frequently. The procedure of this modified method is similar to the Amott, but an additional step is included prior to preparation of the core which consists of centrifuging the core first under brine and then under crude to reduce the plug to irreducible water saturation. Therefore, the Amott-Harvey index is giving by:

$$I = I_w - I_o \quad (1.3)$$

A new range is giving for the wettability criteria. A system is water-wet when  $+0.3 \leq I \leq 1.0$ , intermediate wet when  $-0.3 \leq I \leq 0.3$ , and oil wet when  $-1 \leq I \leq -0.3$ .

**iii. USBM ( U. S. Bureau of Mines)**

Donaldson <sup>14</sup> *et al.* developed a method called USBM based on the two areas under the capillary pressure curves determined with a centrifuge. This method gives an average wettability value of the core. The test consists of the following steps:

1. A core saturated with brine is placed in a glass core holder filled with oil. It is centrifuged until the residual water saturation is obtained (dashed line I in Figure 1.4)
2. The core is placed in another core holder filled with brine and centrifuged at different speeds to displace oil. This volume is measured to obtain the capillary-pressure Curve II.
3. After that, the core is placed in a core holder filled with oil, and the volume of brine is recorded at each incremental increase in speed to obtain capillary-pressure Curve III in Figure 1.4.

The wettability defined by this method states  $W = \log (A_1 / A_2)$ , consequently, a water-wet system has a larger area under the water-displaced-by-oil curve ( $A_1$ ) than the area under the oil-displaced-by-water curve ( $A_2$ ) which means that the value of the logarithm is positive (Figure 1.4a). In contrast, in an oil-wet system, the logarithm of the area ratio is negative (Figure 1.4b). Finally, in Figure 1.4c, a neutral wet system is observed.

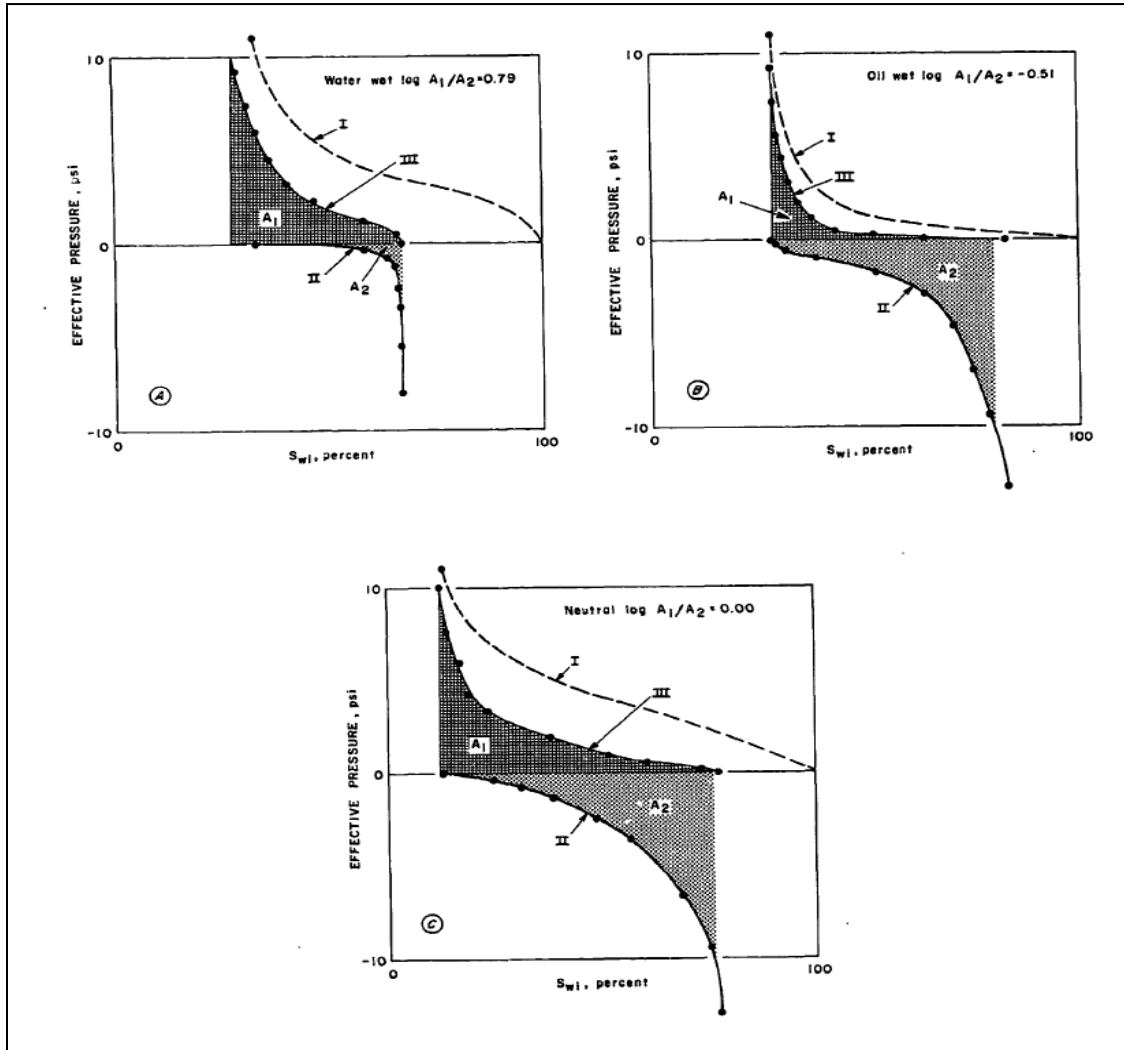

Figure 1.4 Effect of Wettability on the area ratio of capillary-pressure curves: a) Untreated core; b) Core treated with 10 percent Dri-fill 99; c) Core pretreated with oil for 324 hours at 140 °F<sup>14</sup>

*iv. Electrical Resistivity*

E. Sondena<sup>15</sup> *et al.* estimated the water saturation using Archie's equation:

$$I = \frac{R_t}{R_o} = S_w^{-n} \quad (1.4)$$

Where **RI** is defined as the resistivity index, **R<sub>t</sub>** and **R<sub>o</sub>** are the electrical resistivity when the rock is partially saturated with water and when the rock is saturated 100% water. The exponent **n** is defined as the Archie saturation exponent. Then:

$$n = - \frac{\log \left( \frac{R_t}{R_o} \right)}{\log (S_w)} \quad (1.5)$$

They <sup>15</sup> carried out some experiments with different types of oil (crude oil, live crude oil and refined oil) at different conditions (temperature and pressure at reservoir and ambient conditions) to observe the variation of Archie saturation exponent. Therefore, they concluded that the Archie saturation exponent is not affected or decreased slightly with an increase in temperature, and this exponent should be evaluated using only endpoints values.

Other authors <sup>16-18</sup> determined different ranges for Archie saturation exponent depending on the type of rocks and chemicals used in the experiments. Lewis <sup>11</sup> *et al.* determined Archie saturation exponents for Berea sandstones treated with chemical Quilon C from 2.0 (strong water wet) to 5.2 (strong oil wet). These values will be the reference for treated Berea core plugs that will be characterized in the present study.

#### ***1.1.1.2 Qualitative methods***

Qualitative methods <sup>12</sup> determine the degree of water or oil wetness based on: a) the shape of the curves like in relative permeability and recovery curves, or b) behavior of particles in fluids like in flotation methods. The methods that will be used are relative permeability and recovery curves because they are easily obtained in water and surfactant flooding experiments.



***i. Flotation methods***

These methods work for strongly wetted systems. Donaldson <sup>14</sup> *et al.* mentions that this method consists on placing water, oil and sand in a glass bottle, and then, they are shaken. After this, the behavior of the sand grains is observed to determine the wettability of the system. For a strongly oil-wet system, some of the grains will keep suspended at the oil/water interface whereas in the water, the oil-wet sand grains will group and form small oil globules coated with sand. In contrast, for a strongly water-wet system, clean sand grains will be observed on the bottom of the bottle, whereas some grains in the oil will group forming clumps of grains coated by thin layer of water.

***ii. Relative Permeability***

Relative permeability methods <sup>12</sup> may not notice small wettability changes in cores (from strong to moderated oil-wet or water-wet). Nevertheless, they are useful when the cores are strongly water-wet or strongly oil-wet. Craig <sup>19</sup> suggested the rules of thumb to differentiate between strongly oil-wet and water-wet systems as follows (Figure 1.5):

1. Connate water saturations are usually greater than 20 to 25% PV in a water-wet system, but less than 10% PV in an oil-wet system.
2. Water saturation at which water and oil relative permeabilities intersect (are equal) is generally less than 50% for oil-wet systems and greater than 50% for the water-wet systems.
3. The water relative permeability value is much larger (from 50 to 100%) in oil-wet systems, but small values (less than 30%) in water-wet systems.

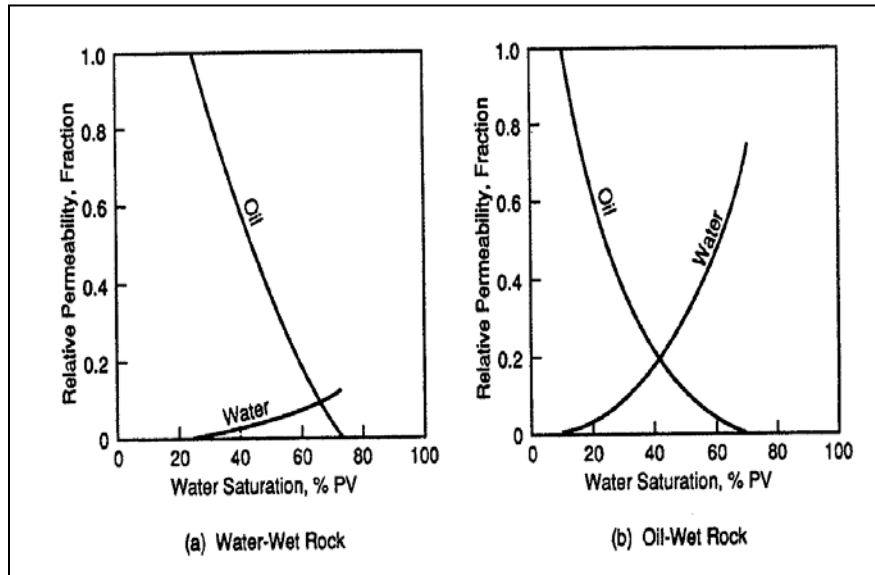

Figure 1.5 Typical water/oil relative permeability curves <sup>1</sup>

*iii. Recovery Curves*

Figure 1.6 <sup>20</sup> shows recovery curves (oil recovery factor) as a function of pore volumes of formation water injected in the water flooding using low viscosity fluids. For a strongly water wet sample (curve A), oil recovery factor is high before breakthrough, and the water/oil ratio rises sharply (curve A') whereas for a strongly oil wet sample (curve B), oil recovery factor is low before breakthrough, and the water/oil ratio rises slowly after breakthrough.

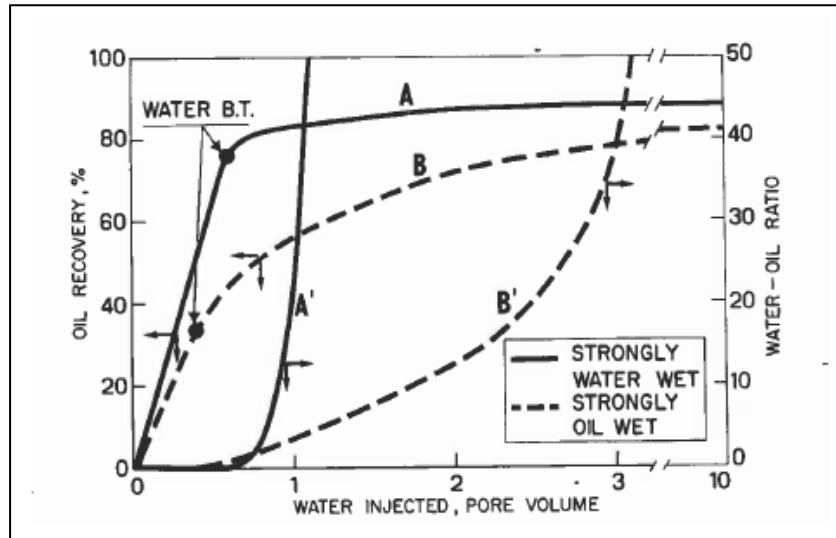

Figure 1.6 Idealized water flood performance of a sandstone type core (linear). Case of low-viscosity fluid <sup>20</sup>

### 1.1.2 Techniques to alter wettability

There are a lot of methods to alter the wetting properties of mineral surfaces to water and oil. Two methods will be reviewed to alter the wettability of a system from strong water wet system to less water wet as preparation for the initial conditions that will be used in the laboratory.

- i. Silanization <sup>21</sup>
- ii. Quilon treatments <sup>22-25</sup>

#### i. Silanization

The silanization procedure <sup>21</sup> consists in a chemical reaction where organosilyl group attacks and displaces the hydroxyl group (OH). In this reaction, organochlorosilane compound (silicon molecules with attached chlorines and non-water organic groups, with the formula  $R_nSiCl_{4-n}$ ) react with the hydroxyl group on silicon dioxides surfaces,

exposing the organic groups and shifting into a hydrophobic system. In his study, trichloro(methyl)silane reacted with water or hydroxyl groups (silica) to release HCl and form a thin film of methylpolysiloxanes which has low critical surface tension (hydrophobic). The reaction is giving by the following chemical reaction <sup>21</sup>:



The procedure used by Tabrizy <sup>22</sup> in his research to alter the wettability from strong water-wet to strong oil-wet is:

1. Cleaning procedures are applied to the glass beads with an HCl solution (20%) to get a water wet system.
2. Rinse the glass beads with distilled water to remove all residues and then put in an oven for 2 hours at 100 °C.
3. The glass beads are incubated for 15 minutes in a 2% solution of trichloro(methyl)silane and 98% of toluene. A thin film of methylpolysiloxanes covers the grains. It has to be taken into account the HCl formation during this reaction before removing the glass beads from the reaction vessel.
4. Finally, rinse the glass beads with methanol and then dried in the oven. This issue will help to the cross linking reaction and the formation of monolayer silane film.

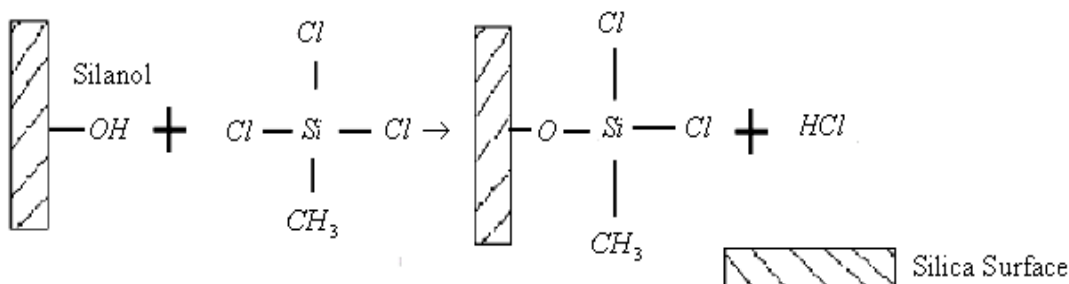

## *ii. Quilon treatments*

Other techniques have been developed to alter the wettability in sandstones cores like Quilon treatments <sup>22 - 25</sup>. Maini <sup>22</sup> used Quilon-S whereas Lewis <sup>23</sup> worked with Quilon-C to change the hydrophilic surfaces into hydrophobic (oil-wet). Quilon-C is a chromium complex that contains a fatty acid group (C<sub>14</sub>-C<sub>18</sub>). The chromium in Quilon-C reacts with polar groups on charged surfaces (negative) and forms an insoluble layer of polymerized complex which bonds to the rock surface by chromium. The exposing fatty acids groups repel water, thus the rock surface is hydrophobic.

Lewis <sup>23</sup> used the following procedure to get a hydrophobic surface: The cores were vacuumed dry for 2 hours, and then saturated with a 20% solution of Quilon-C and reagent grade isopropyl alcohol. After that, the cores were evacuated for 4 hours. The procedure was repeated again, and then the core was flushed with ethanol until effluent was a very slight green color. Finally, the core was heated in an oven at 60 °C for the whole night. This total procedure was repeated again to get a stable treatment.

## **1.2 Surfactants**

Rosen <sup>26</sup> defined surfactants as the chemical substances that adsorb on or concentrate at a surface or fluid/fluid interface when present at low concentrations in a system. They consist of a lipophilic portion (hydrocarbon group) and hydrophilic portion (polar group) which are the non-polar (tail) and polar (head) portions respectively as shown in Figure 1.7.

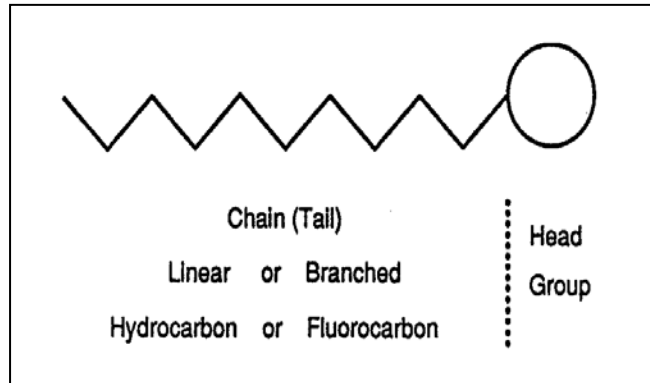

Figure 1.7 Schematic of surface-active molecule <sup>1</sup>

According to the ionic nature of the hydrophilic group, surfactants can be classified in four groups <sup>1,26</sup> as follows:

- **Anionic.**- In these surfactants, charge in the head group is negative. They are the most common used in EOR processes because of the properties like low adsorption on reservoir rock, stable and availability to manufacture economically (inexpensive).
- **Cationic.**- These surfactants are characterized by the positive charge in the head group. They are rarely used because of its adsorption onto the reservoir rock (negative charge), and high costs compared with nonionic and anionic surfactants.
- **Zwitterionic.**- It has both charged groups: positive and negative which makes them easily absorbed by charged surfaces without forming hydrophobic film. The main disadvantage is that they are usually not soluble with organic solvents.
- **Nonionic.**- Surfactants do not ionize, thus the tail group is smaller than the head group. They have tolerance to the high-salinity brine (hard water), but poor properties to reduce the IFT, thus they are used as a co-surfactants to get better behavior of the surfactant systems. Some advantages of these surfactants are: 1) compatible with all types of surfactants, 2) soluble in organic solvents and water. Unfortunately, the main

disadvantage is that the adsorption onto charged surfaces is strong (no electrical effects).

### ***1.2.1 Surfactant adsorption***

Surfactant adsorption <sup>27</sup> occurs when surfactant is in contact with a surface or interface, which may lead to wettability alteration (positive effect) or loss of surfactant from solution (negative effect).

#### ***1.2.1.1 The electrical double layer***

According to Rosen <sup>26</sup>, at any interface the electrical charges are not distributed equally between the two phases. This unequal distribution causes one side of the interface to acquire a net charge of a particular sign and the other side to acquire a net charge of the opposite sign, giving rise to a potential across the interface.

#### ***1.2.1.2 Adsorption at solid/liquid interfaces***

Adsorption of surfactant onto porous media <sup>26, 27</sup> (on the walls of throats or pores, or on fine particles in rock pores) can constitute a loss of valuable surfactant that can determine the feasibility of the oil recovery project.

Static <sup>1</sup> (batch equilibrium tests) and dynamic <sup>1</sup> (core flood measures) experiments are usually used to measure the surfactant adsorption. In the first case, batch equilibrium tests, a specified mass of crushed rock is mixed with a known volume of surfactant solution (at a known concentration) in a sealed container. Fluids samples are withdrawn at intervals and analyzed until the system is at equilibrium (concentration keeps constant with time as shown in Figure 1.8. Material balance is used to calculate adsorption. For the second case, the dynamic core flood method, surfactant slugs of increasing size are

injected into cores until retention reaches a maximum and constant value as shown in Figure 1.9.

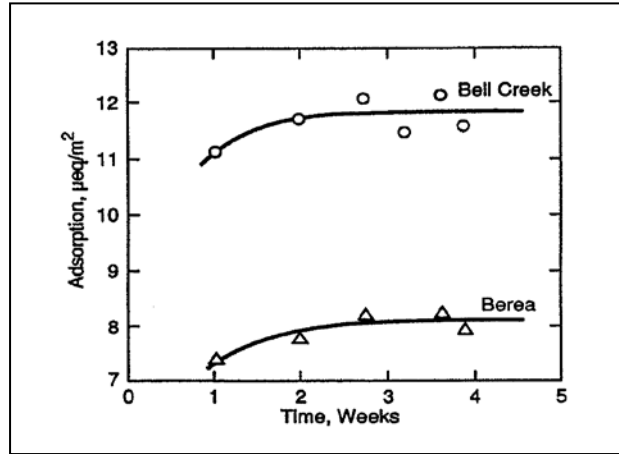

Figure 1.8 Adsorption vs. time <sup>1</sup>

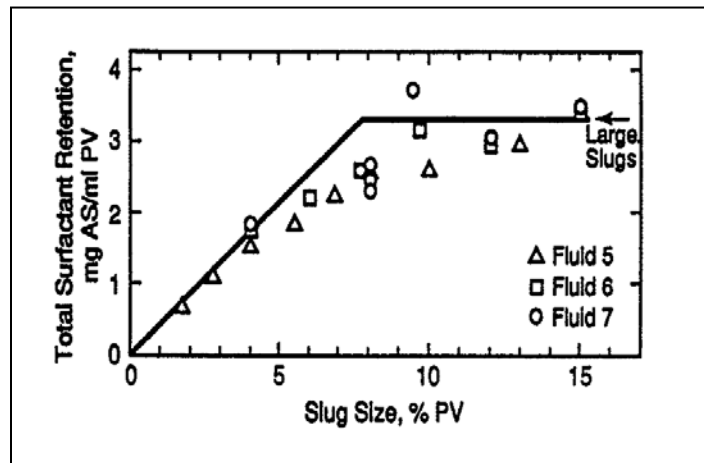

Figure 1.9 Surfactant retention during core flood experiments <sup>1</sup>

The surfactant adsorption onto porous media is affected by surfactant type, concentration and equivalent weight; temperature; brine salinity and hardness; solution pH; rock minerals; wettability; presence of a residual oil phase and the flow rate of the solution.



### ***1.2.1.3 Wettability alteration***

Surfactant adsorption onto solid surface <sup>27</sup> decreases IFT and shifts the wettability of the solid surface making it water-wetting or oil-wetting depending on the orientation between adsorbed surfactant molecules and solid surface. If the orientation of the head groups (hydrophobic) point away from the surface, oil-wetting reduces whereas water-wetting increases. Conversely, if the tail groups (hydrophilic) point away from the surface, oil wetting increases whereas water-wetting decreases.

### ***1.2.1.4 Liquid/Liquid interfacial adsorption and IFT reduction***

Surfactant can decrease IFT between two immiscible fluids (oil and brine) by adsorbing at their interface <sup>26, 27</sup>, displacing some oil and water molecules there. Then, the surfactant molecules arranged by themselves orienting their hydrophobic portion into the oil, and the hydrophilic portion into the brine

#### ***a) Ultralow interfacial tension***

In order to displace the residual oil from the porous media, IFT should be reduced to reach an ultralow value <sup>26</sup> (around  $10^{-3}$  dyne/cm) between the 2 immiscible fluids (oil and brine) and surfactant forming one phase that is called microemulsion. Depending of the nature of surfactants, temperature or salinity increases may help that systems change in phases and solubilization.

### ***1.2.2 Micelle formation and critical micelle concentration (CMC)***

Surfactants also can form micelles (colloidal aggregates in solution) depending on the concentration into a solvent (Figure 1.10). When the surfactant concentration is very low, dissolved surfactants molecules are dispersed as monomers, whereas increasing the

concentration, the molecules tend to aggregate until getting the critical micelle concentration (CMC<sup>1</sup>) which is the concentration at which the micelles start to form. For the case of a hydrocarbon solvent, micelles are formed with the head group directed inward and the tail group outward with a continuous hydrocarbon phase. (Figure 1.10 – upper right side). Water is solubilized into the interior of this type of micelle. In contrast, when water is the solvent, the tail group is oriented inward and the head group is outward (Figure 1.10 – lower right side) to form micelles which allow that significant amounts of oil can be solubilized in their interior. This process in which micelles solubilize a phase which is not miscible with the solvent is called microemulsions.

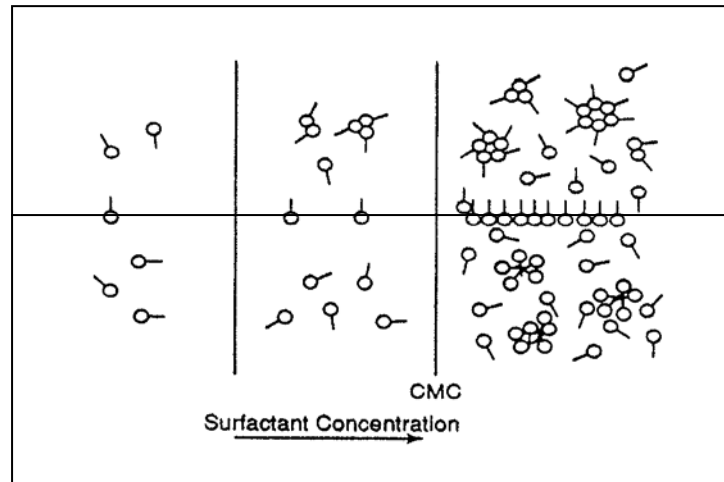

Figure 1.10 Formation of micelles<sup>1</sup>

### 1.2.3 Phase behavior of Microemulsions:

Green and Paul Willhite<sup>1</sup> (1998) state that microemulsions can be designed to have ultralow IFT and high solubilization with oil and brine which make them very attractive in EOR processes. In order to study the phase behavior of microemulsions, pseudoternary diagrams<sup>28</sup> (equilateral triangle) have been plotted to represent each of the true pseudocomponents that form a microemulsion like surfactant (surfactant/cosurfactant

ratio), brine (water + NaCl) and hydrocarbons pseudocomponents in each of the apices (Figure 1.11).

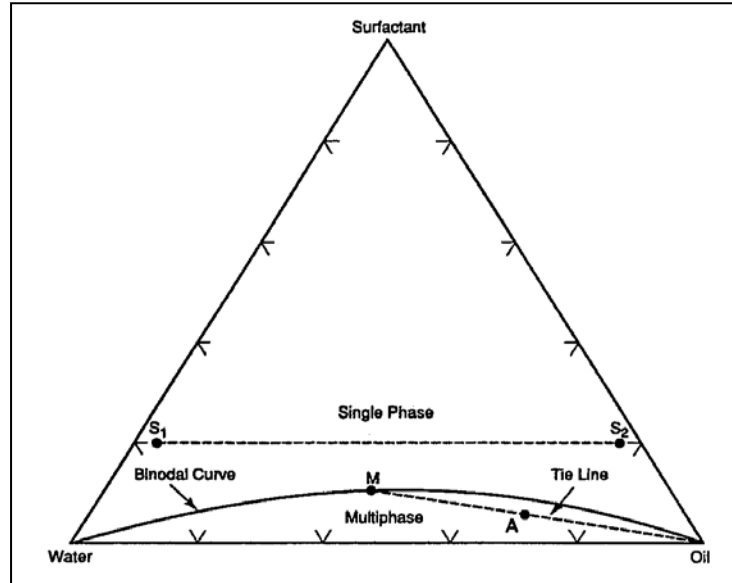

Figure 1.11 Pseudoternary phase diagram for a micellar solution <sup>1</sup>

Nelson and Pope <sup>28</sup> showed in their paper that pseudoternary diagrams show different phase behavior of microemulsions depending on the salinity concentration in water phase (Figure 12a). At low brine salinity, a type II (-) system (lower microemulsion or excess-oil phase) is formed where all water is dissolved into the microemulsion whereas not all oil is solved into it. When the salinity starts to increase reaching an intermediate salinity, a complex system, type III (middle microemulsion) appears where some water and oil is dissolved into the microemulsion. Finally, at high brine salinity, a type II (+) system (upper microemulsion or excess-water phase) is formed with all oil dissolved in the microemulsion and some remaining water (Figure 1.12b). Additionally, the salinity brine also affects the IFT between equilibrium phases as Figure 1.13 depicts. As it is seen, there is an optimal salinity in the surfactant/oil/brine system close the critical point where the three phases become chemically indistinguishable and thus exhibit ultralow IFT between all phases.

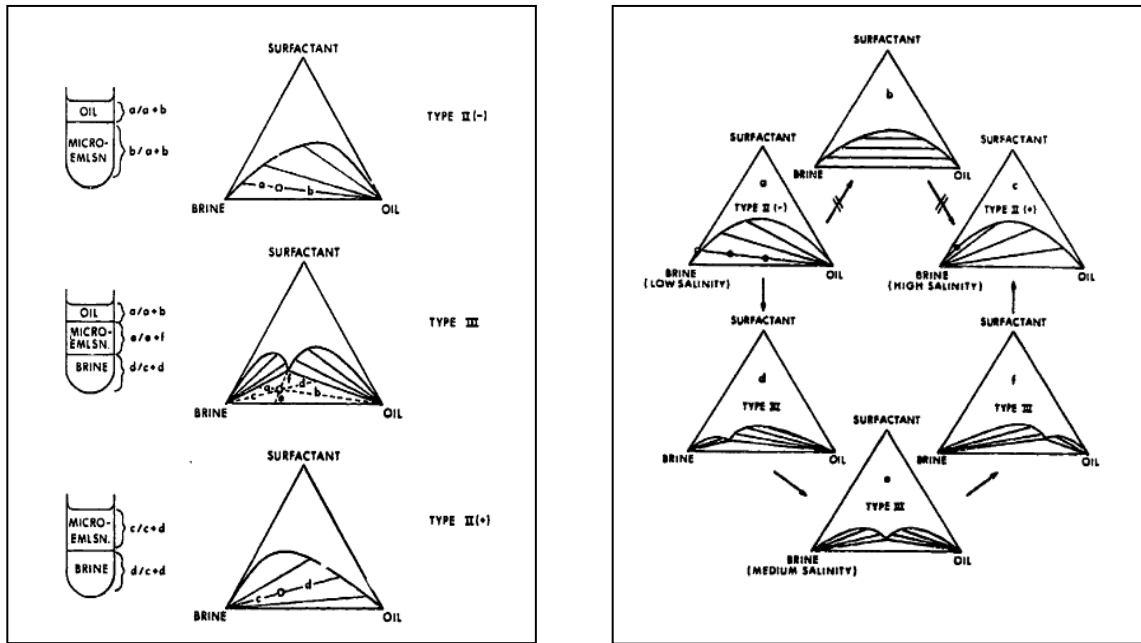

Figure 1.12 a) Ternary representations of phase diagrams, b) Generalized phase diagrams illustrating the effect of changing salinity <sup>28</sup>

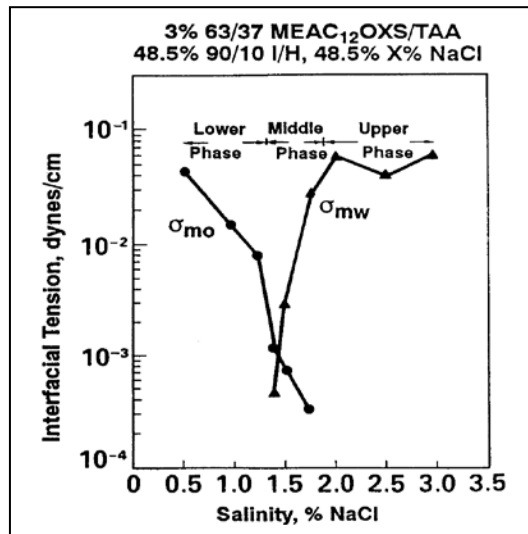

Figure 1.13 IFT as a function of salinity <sup>1</sup>

Phase behavior of microemulsions and IFT can also be affected by the following parameters <sup>1</sup>:

- **Oil type:** The effect is related with the amount of aromatics that the oil type could contain. An increment in the aromatics fraction will decrease the optimal salinity and IFT as shown in Figure 1.14.

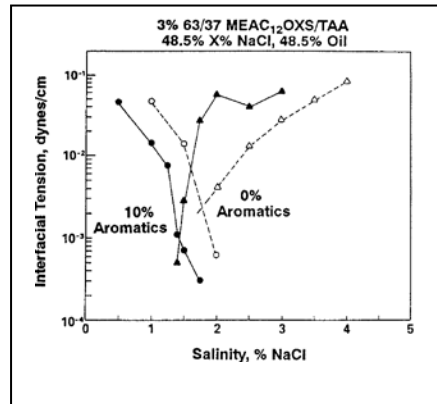

Figure 1.14 IFT, effect of oil <sup>1</sup>

- **Co-surfactant type:** The type and amount of surfactant has really impact on the phase behavior and IFT. Research of 2 types of alcohols <sup>1</sup> (TBA and TAA) added to surfactant systems have changed the optimal salinity and IFT, and have made them more hydrophilic or hydrophobic as depicted in Figure 1.15.

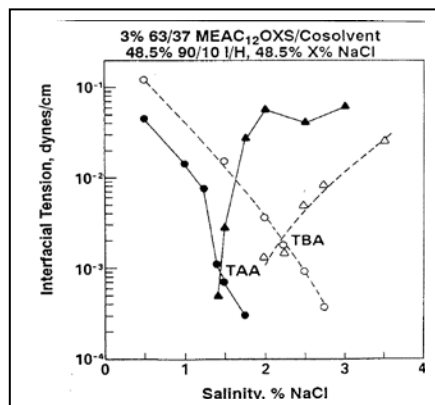

Figure 1.15 IFT, effect of alcohol <sup>1</sup>

- **Temperature:** IFT and optimal salinity are increased when the temperature is increased as shown in Figure 1.16.

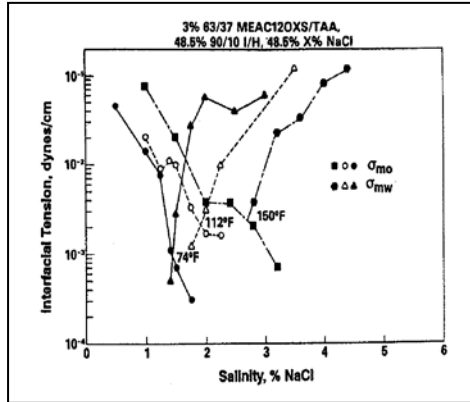

Figure 1.16 IFT, effect of temperature <sup>1</sup>

- **Divalent Ions:** Divalent ions ( $Mg^{++}$  and  $Ca^{++}$ ) are found in brine, in porous matrices of reservoir rocks and surfactants. These ions can precipitate or generate incompatibility between brine and surfactant by dissolution or ion exchange. The presence of divalent ions decreases the optimal salinity and increases the IFT as shown in Figure 1.17.

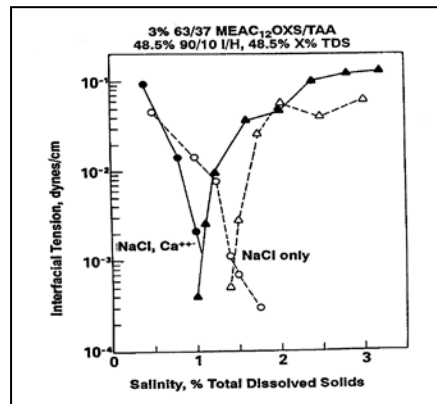

Figure 1.17 IFT, effect of  $Ca^{2+}$  . <sup>1</sup>

- **Surfactant Structure:** Gale and Sandvik <sup>29</sup> examined the effect on IFT with oil by measuring IFT as a function of the surfactant equivalent weight. Also, they carried out some IFT experiments varying the percentages of low and high-equivalent weight surfactants in mixture concluding that surfactant properties are dominated by high-equivalent-weight molecules.

- **Pressure:** Nelson<sup>30</sup> concluded that there is a possible effect on behavior in crude oils containing significant amount of gas, whereas there is a small effect (negligible) in liquid systems.
- **Polymer Addition:** Polymers are usually added to the chemical process in order to increase the solution viscosity (mobility ratio) causing some small shifts as Pope<sup>31</sup>*et al* pointed out like in salt concentration (decreasing) and IFT (increasing) as shown in Figure 1.18. Nevertheless, their research concluded that the main impact is the shift in the three-phase boundaries.

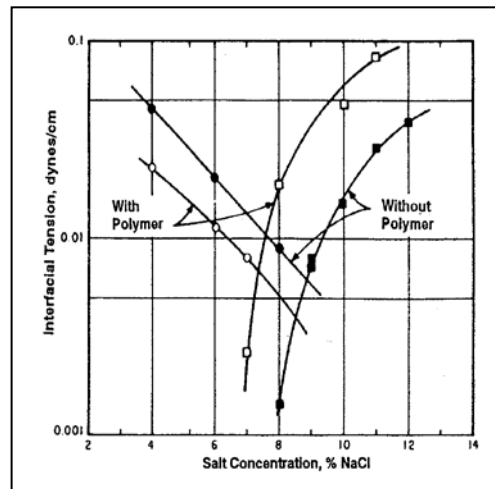

Figure 1.18 IFT, effect on polymer<sup>1</sup>

## 1.2.4 Surfactant flooding

### 1.2.4.1 Micellar/polymer process

A chemical flooding process<sup>1</sup>, usually called microemulsion, surfactant, micellar, low tension and soluble oil; have been established to reach an ultralow IFT (around  $10^{-3}$  dynes/cm) between oil and water in order to decrease the residual oil saturation.

Micellar/polymer process (Figure 1.19) is usually implemented as a tertiary recovery process after water flooding, and consists of the following steps <sup>1, 32</sup>:

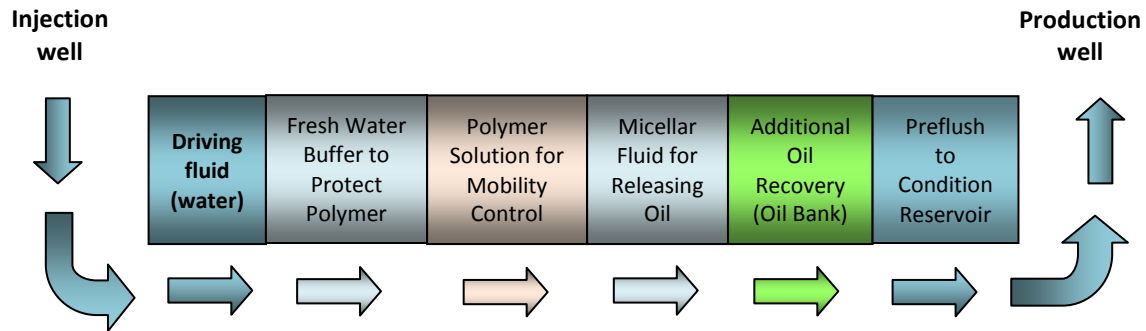

Figure 1.19 Surfactant/polymer process <sup>1</sup>

- a) A preflush should be performed to condition the reservoir which main objective is to reduce the salinity and pH of brine which affects the surfactant behavior, and to decrease adsorption and loss of surfactant contained in the micellar solution <sup>1</sup>. Most of time, when micellar/polymer process is established as a tertiary recovery, water flooding (1.0 PV) could be designed as a preflushing fluid.
- b) A primary surfactant slug (around 0.1 - 0.3 PV) is injected which has an ultralow IFT with both oil (residual and trapped) and brine which moves together ahead of the surfactant slug forming an oil bank. Moreover, in order to avoid viscous fingering of the primary slug into the oil bank, a favorable mobility ratio should exist between them.
- c) A mobility buffer (1.0 PV), usually polymer in water, is injected to displace the primary slug. The mobility buffer concentration usually varies from the original polymer concentration to 100% brine. The displacement efficient depends on the



favorable mobility ratio between the primary slug and mobility buffer, and their low IFT; which leave a small amount of surfactant trapped in the porous media.

d) Finally, brine (driving fluid) is injected after the mobility buffer which reduces the cost of project by no using polymers.

Figure 1.20<sup>1</sup> shows cumulative recovery curve vs. pore volume injected obtained during micellar/polymer displacement test in the laboratory.

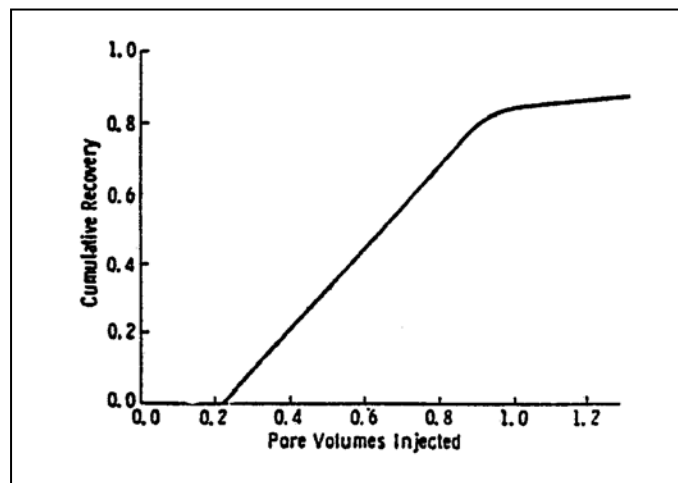

Figure 1.20 Cumulative recovery curve, laboratory micellar/polymer displacement test<sup>1</sup>

# ***EXPERIMENTAL PROCEDURES***

## ***2.1 Properties of fluids and solid surfaces***

### ***i. Wettability modifier***

The chemical product used as wettability modifier is Quilon L which characteristics are shown in Table 2.1 <sup>33</sup>.

Table 2.1 Typical Analyses and Properties of Quilon L <sup>33</sup>

Appearance	dark-green liquid
Odor	Alcoholic
Chromium as Cr, wt. %	9.2
Chloride as Cl, wt. %	12.7
Fatty Acid (C14-18), wt. %	21.2
Boiling point, C	82.0
Freezing point, C	4.0
Density at 20 C (lb/gal)	8.6
Solubility in water	Complete

### ***ii. Minerals***

Minerals that will be analyzed are: Quartz ( $\text{SiO}_2$ ), Kaolinite ( $\text{Al}_2(\text{Si}_2\text{O}_5)(\text{OH})_4$ ) and Dolomite-calcite ( $\text{Ca,Mg,FeCO}_3$ )

### ***iii. Porous media***

Berea core plugs (500 mD) will be used for experiments.

*iv. Brine*

Composition of artificial formation water (FW) is shown in Table 2.2

Table 2.2 Composition of formation water

Salt	Formation water (g/L)
CaCl <sub>2</sub> · 2H <sub>2</sub> O	37.6
MgCl <sub>2</sub> · 6H <sub>2</sub> O	15.0
NaCl	88.0
Na <sub>2</sub> SO <sub>4</sub>	0.2

*v. Surfactant solution*

WITCOLATE 7093<sup>34</sup> (Sodium C6-10 Alcohol Ether Sulfate), manufactured by Akzo Nobel Surface Chemistry LLC, has been selected as a surfactant. Specification and properties are shown in Table 2.3.

Table 2.3 Specifications and properties of WITCOLATE 7093<sup>34</sup>

Form	Liquid
Odor	Faint odor
Color	Light yellow
pH	7.0 to 8.5
Boiling point, C	100.0
Density at 25 C, g/ml	1.10
Viscosity at 25 C, cp	0.58
Solubility	Soluble in water, methanol, acetone

*vi. Oil*

n-Decane with the properties in Table 2.4<sup>35</sup> is used

Table 2.4 Physical and chemical properties of n-Decane <sup>35</sup>

Form	Liquid
Odor	Characteristic
Color	Colorless
Molecular weight (g/mol)	142.28
Boiling point, °C	174.0
Melting point, °C	-30.0
Density (g/ml)	0.73
Viscosity at 20 °C/38 °C, cp	0.92 / 0.50
Solubility in water	Insoluble

## 2.2 Experiments

### 2.2.1 Static experiments

In static experiments, the wettability alteration of minerals and crushed Berea by the Quilon L are studied.

#### i. Procedure

Two g of mineral (quartz, kaolinite and calcite) or crushed Berea rock and 3.0 wt % Quilon L solution (5ml or 5g) are transferred to tubes with known weight. The weight of the tube containing the mixture is determined. The mixtures are mixed slowly by shaking and then stored with tubes open at 90 °C for 5 days.

#### ii. Wettability characterization

Wettability is characterized for treated and untreated minerals and crushed rock at room temperature. The prepared mixtures are transferred to a measuring cylinder (with same volume and shape in all experiments) and 25 ml FW is added. The mixture is stirred in 10

minutes. The sedimentation in mixtures of treated and untreated material is followed in parallel. Mixtures behavior is observed at different time: 0, 1, 5, 10, 30 and 60 minutes.

### **2.2.2 Stability test**

The stability of Berea rock treated with Quilon L is studied in core plug flooding experiments.

#### ***i. Preparation of treated core plug***

1. A Berea core plug (dry weight) is mounted into a triaxial core holder at 50 bar (overburden pressure).
2. 10 pore volumes of Quilon L solution of 3.0 % wt are injected at 0.5 ml/min and 5 bar back pressure at room temperature in both directions (5 PV in each direction) to make sure that the core has been saturated. The core plug is demounted.
3. The core plugs are aged at 90 °C for 5 days. Measure weight to confirm that it is quite similar to the step 1.

#### ***ii. Floods***

Effluent samples are characterized by visual inspection in floods at room temperature (25 °C). A sketch of the flooding rig that should be used is shown in Figure 2.1.

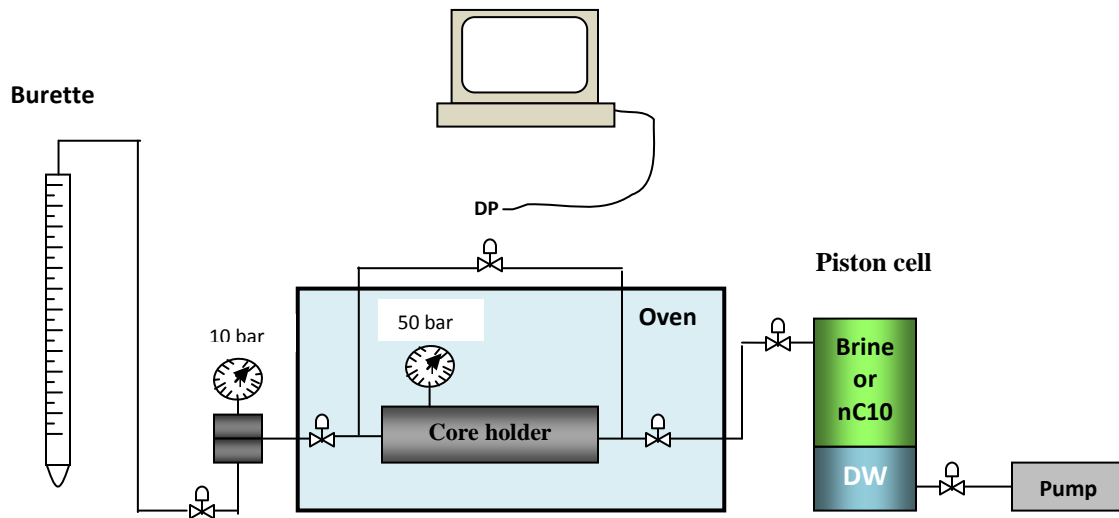

Figure 2.1. Sketch of flooding rig

The following fluids are injected at rate of 0.1 ml/min to core plugs with treated and untreated material:

- a) 10 pore volumes of formation water (water flooding 1). Measure the resistivity ( $r_o$ ) of the core at 100% water saturation.
- b) 10 pore volumes of 1.0% wt surfactant solution
- c) 10 pore volumes of formation water (water flooding 2)
- d) 10 pore volumes of n-Decane
- e) Establish  $S_{wi}$  by continues injecting n-Decane. Increase the rate gradually until water production stops at the highest rate. Measure the resistivity ( $r_t$ ) of the core at partially water saturation and calculate  $n$ .

For the treated core plug the following steps are additionally carried out

- f) MeOH injection to clean the core plug
- g)  $N_2$  injection at 60 °C to dry the core
- h) Water flooding to measure water effective permeability
- i) n-Decane flooding to establish  $S_{wi}$
- j) Spontaneous imbibition in formation water

### **2.2.3 Water flooding and Surfactant flooding experiments**

Water flooding and surfactant flooding is studied in treated and untreated Berea core plugs.

#### **2.2.3.1 Homogeneous treatment**

A homogeneous treatment is applied in order to obtain strongly oil- or water-wet core plugs. In this treatment, the modification of wettability is before drainage.

##### ***i. Preparation of Berea core plugs***

1. Measure length, diameter and weight of dry cores
2. The Berea core plug (dry core) is mounted into a triaxial core holder at 50 bar (overburden pressure)
3. Quilon L solutions (Quilon L diluted in water) of **0.0, 0.1, 1.0 and 3.0 wt%** (5 pore volumes in each direction) are injected at a rate of 0.5 ml/min to Berea core plugs at room temperature. Demounted the core plug.
4. The core plugs are aged at 90°C for 5 days. Measure weight to confirm that it is quite similar to the step 1.
5. Removal of treatment fluid by injection of formation water (5 pore volumes at 0.1 ml/min). Measure  $r_o$  and calculate  $K_{abs}$ .
6. Treated and untreated core plugs are drained to initial water saturation ( $S_{wi}$ ) by nitrogen with gradually increasing the pressure (from 0.3 bar to 15 bar) using the unconfined porous disc method (estimated time in the porous disc is around 3 weeks).
7. Nitrogen is replaced with n-Decane to establish initial conditions ( $S_{wi}$ ,  $k_{ro}$ ,  $r_t$  and  $n$ ).

ii. **Floods**

1. *Water flooding*: Formation water is injected to the Berea core plugs with gradually increasing the injection rate: 0.1, 0.3, 1.0, 3.0 and 10 ml/min. Calculate  $k_w$ ,  $k_{rw}$  and  $S_{ow}$ .
2. *Surfactant flooding*: Surfactant solution of **1.0 wt %** is injected to the core plugs with gradually increasing the injection rate: 0.1, 0.3, 1.0, 3.0 and 10.0 ml/min. Establish  $S_{oc}$ . At the lowest rate, effluent samples are analyzed for surfactant concentration using the two phase titration method (**Appendix A**).
3. Formation water is injected at 1.0 ml/min to displace the surfactant.
4.  $NO_3$  formation water is injected at 1.0 ml/min. Mohr's titration method of chloride (**Appendix B**) is used to calculate accessible water volume ( $V_w$ ).
5. Formation water is injected at 1 ml/min to replace  $NO_3$  formation water
6. *n-Decane flooding*: n-Decane is injected to the core plugs with gradually increasing the injection rate: 0.1, 0.3, 1.0, 3.0 and 10.0 ml/min. Establish final conditions ( $k_o$ ,  $k_{ro}$  and  $S_{wi}$ )

2.2.3.2 **Heterogeneous treatment**

A heterogeneous treatment is applied in order to obtain mixed-wet core plugs<sup>11</sup>. In this treatment, the modification of wettability is after drainage to  $S_{wi}$ .

i. **Preparation of Berea core plugs**

1. Berea core plugs are saturated by injecting formation water. Measure the resistivity ( $r_o$ ) of the core at 100% water saturation at room temperature.
2. Then, core plugs are drained to initial water saturation ( $S_{wi}$ ) by nitrogen with gradually increasing the pressure using the unconfined porous disc method at 25 °C.
3. Nitrogen is replaced with n-Decane to establish initial conditions ( $S_{wi}$ ,  $k_{ro}$ ,  $r_t$  and  $n$ ) at 38 °C.



4. Quilon L solution (Quilon L diluted in n-Decane) of **3.0 wt %** is injected (5 pore volumes in each direction) at rate of 0.5 ml/min to untreated core plugs at  $S_{wi}$  at 38 °C.
5. Two possibilities may be chosen to measure the resistivity ( $r_t$ ) of the core at partially water saturation and calculate  $n$ :
  - a) n-Decane is injected (5 pore volumes) at rate of 0.5 ml/min at 38 °C, or
  - b) Core plug is aged at 90 °C for 5 days, and then n-Decane is injected (10 pore volumes) at rate of 0.2 ml/min at 38 °C.

ii. ***Floods***

The core flooding experiments are carried out in core plugs of mixed wettability at 38 °C using 5 bar back pressure.

1. *Water flooding*: Formation water is injected to the Berea core plugs with gradually increasing the injection rate: 0.1, 0.3, 1.0, 3.0 and 10 ml/min. Calculate  $k_w$ ,  $k_{rw}$  and establish  $S_{ow}$ .
2. 5 PV of  $NO_3$  FW + LiCl used as a tracer is injected at 1.0ml/min. Both Li analysis and Mohr's titration method for  $Cl^-$  test is used to calculate accessible water volume ( $V_w$ ).
3. Formation water is injected at 1.0 ml/min to replace  $NO_3$  formation water.
4. *Surfactant flooding*: Surfactant solution of **1.0 wt %** is injected to the core plugs with gradually increasing the injection rate: 0.1, 0.3, 1.0, 3.0 and 10.0 ml/min. Establish  $S_{oc}$ . At the lowest rate, effluent samples are analyzed for surfactant concentration.
5. Formation water is injected at 1.0 ml/min to displace the surfactant.
6. *n-Decane flooding*: n-Decane is injected to the core plugs with gradually increasing the injection rate: 0.1, 0.3, 1.0, 3.0 and 10.0 ml/min. Establish final conditions ( $k_o$ ,  $k_{ro}$  and  $S_{wi}$ ). Measure  $r_t$  and calculate  $n$ .

7. Spontaneous imbibition is applied to core plugs.

*Note:* The criteria for increasing the rate (flooding) are that the oil/water production has stopped and the differential pressure keeps constant.

# **RESULTS AND DISCUSSION**

## **3.1 ROCK AND FLUID PROPERTIES**

Cores 1 and 2 were used for stability test; cores 3, 4, 5 and 6 for homogeneous treatment; and cores 7, 8 and 9 for mixed treatments. Properties of the cores are shown in Table 3.1

Table 3.1 Properties of Berea core plugs

Core	Length (cm)	Diameter (cm)	Porosity (%)	k (mD)	PV (ml)	Quilon L (wt. %)	Experiment
1	8.10	3.76	0.18	852	16.18	3.0	Stability test
2	9.04	3.79	0.19	---	19.79	0.0	Stability test
3	9.01	3.78	0.22	610	22.06	0.0	Homogeneous
4	8.99	3.77	0.21	629	20.85	0.1	Homogeneous
5	8.99	3.77	0.20	673	19.56	1.0	Homogeneous
6	9.04	3.76	0.19	723	18.91	3.0	Homogeneous
7	8.96	3.78	0.15	432	15.48		Mixed
8	8.98	3.77	0.18	418	18.14		Mixed
9	9.02	3.78	0.16	460	16.26		Mixed

Properties of artificial formation water (brine) are shown in Table 3.2.

Table 3.2 Properties of formation water

Density at 38 °C (g/ml)	1.08
Viscosity at 38 °C (cp)	1.00
pH	5.30

Surfactant solution of **1.0 % wt.** (WITCOLATE 7093 diluted in formation water) is used in surfactant flooding. Physical properties are shown in Table 3.3

Table 3.3 Physical properties of Surfactant solution of 1.0 % wt.

Density at 20 °C (g/ml)	1.08
Concentration (mg/g)	9.37
Type of microemulsion	Lower
Type of surfactant	Anionic
Viscosity at 25 °C / 38 °C	1.20 cp / 0.96 cp

### 3.2 STATIC EXPERIMENT

As described in the procedure before, wettability is characterized for untreated and treated minerals mixed with formation water and stirred (first case) and n-Decane (second case). Pictures of the mixtures are taken after 0, 1, 5, 10, 30 and 60 minutes.

Sedimentation of untreated (left of picture) and treated (right of picture) after 60 minutes of each mineral and crushed Berea rock is shown in pictures below.

#### i. Calcite

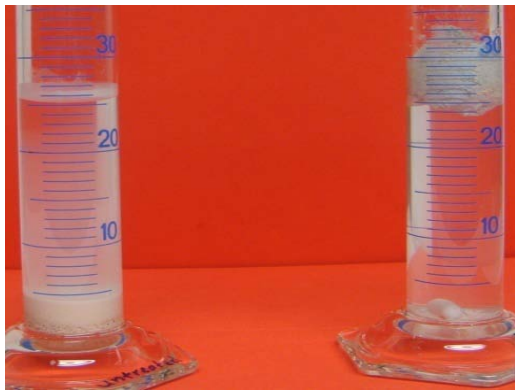

Figure 3.1 Calcite in formation water

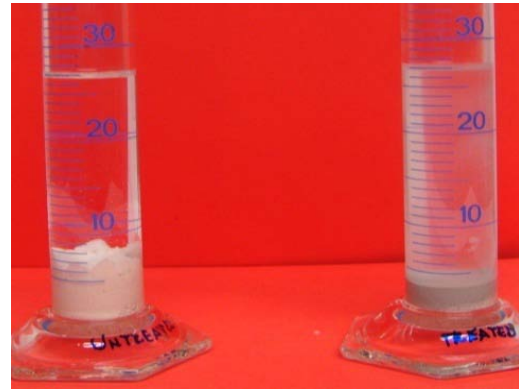

Figure 3.2 Calcite in n-Decane

As it is seen in Figure 3.1, when samples are mixed with formation water and stirred, untreated calcite dissolves in formation water (a little whiter color) and most of it starts to settle down on the bottom like a powder which is interpreted as *water wet surface*.

Conversely, sedimentation of small amount of treated calcite to bottom, but most of it keeps floating which is interpreted as *oil wet surface*. In Figure 3.2 (n-Decane), untreated calcite precipitates on the bottom which is related with *water wet surface*, whereas treated calcite settles down on the bottom like a powder which is *oil wet surface*

ii. *Quartz*



Figure 3.3 Quartz in formation water



Figure 3.4 Quartz in n-Decane

In Figure 3.3, particles of untreated Quartz settles down on the bottom like powder which is interpreted as *water wet surface*, whereas treated Quartz precipitates and then settles down which is related with *oil wet surface*. Conversely, in Figure 3.4, particles of untreated Quartz are floating and dispersed in and just few ones settles down on the bottom which is *water wet surface*, whereas treated Quartz settles down on the bottom like a powder which is related with *oil wet surface*. Furthermore, a green color of the solution is observed in both cases which mean that some Chromium of Quilon L is soluble in both water and n-Decane.

iii. **Kaolinite**



Figure 3.5 Kaolinite in formation water

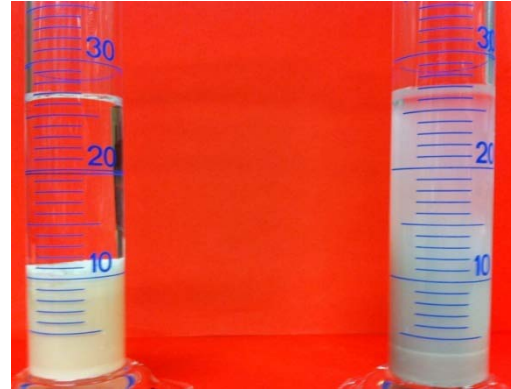

Figure 3.6 Kaolinite in n-Decane

Figure 3.5 shows that untreated Kaolinite particles settle down with time on the bottom like a powder which is *water wet surface*, whereas a little treated Kaolinite particles settle down, and most of it keeps floating which is *oil wet surface*. Contrary, in Figure 3.6, untreated particles are suspended all time and few of them precipitated which is *water wet surface*, whereas treated Kaolinite particles settled down like a powder which is related with *oil wet surface*.

iv. **Berea**

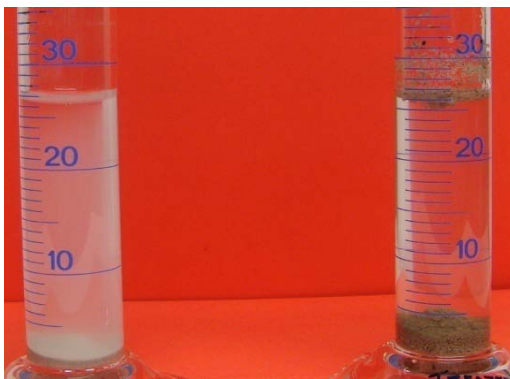

Figure 3.7 Berea in formation water

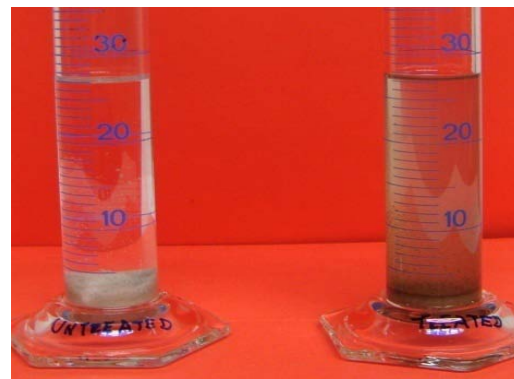

Figure 3.8 Berea in n-Decane

In Figure 3.7, some particles of untreated Berea particles dissolve in formation water (small particles give white color to solution) and few ones settle down on the bottom like

a powder which is related with *water wet surface*, whereas treated Berea sample precipitates which is *oil wet surface*. Conversely, Figure 3.8 shows that few untreated Berea particles are suspended and most of it settles down on the bottom which is *water wet surface*, whereas treated Berea particles settled down on the bottom like a powder which is related with *oil wet surface*. Additionally, there is change in color (turns into brown) in treated Berea sample with n-Decane because of the precipitation of iron (ferric and ferrous oxide) presents in Berea sample.

### 3.3 STABILITY TEST

Stability test is carried out in 2 Berea core plugs: treated (3.0 % wt. Quilon L solution) and untreated one.

#### i. Treated core plug

##### 1. Water flooding 1:

In water flooding 1, it is observed that all samples have some yellow particles settled down on the bottom that can be Fe released from Berea (Ferric and ferrous oxides). Moreover, pH increases from 4.1 in the first effluent sample to 5.1 in last ones which are values between the pH of Quilon L (pH = 3.0) and formation water (pH = 5.3). This shows that not all Quilon L is absorbed by the rock, but it remains inside the porous media and reacts with formation water varying the pH during the flooding. Table 3.4 shows calculations obtained during flooding.

Table 3.4 Effluent samples of treated Berea core plug during water flooding 1

PV injected	Pressure drop (mbar)	Q (ml/min)	Kabs (mD)
10.5	20.1	0.1	679

## 2. Surfactant flooding:

Collected effluent samples are transparent (around 1.7 PV), and then some yellow particles are settled down on the bottom (up to 10.1 PV). Breakthrough is around 4.8 PV where surfactant concentration keeps constant (9.37 mg/g) as shown in Figure 3.9.

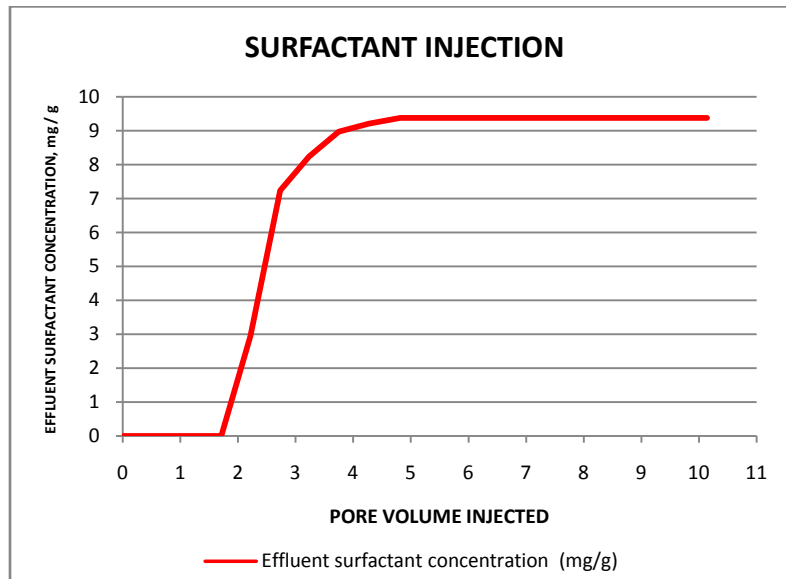

Figure 3.9 Effluent surfactant concentration vs. PV injected during surfactant flooding in a treated core.

## 3. Water flooding 2:

As it is seen in Figure 3.10, there is an opposite effect as the surfactant flooding curve (Figure 2). The concentration of fluid starts to decrease from 9.37 mg/g (surfactant) to 0 when 5 PV of formation water have been injected. Furthermore, all effluent samples show light yellow particles on the bottom. Table 3.5 depicts the main parameters in this flooding.



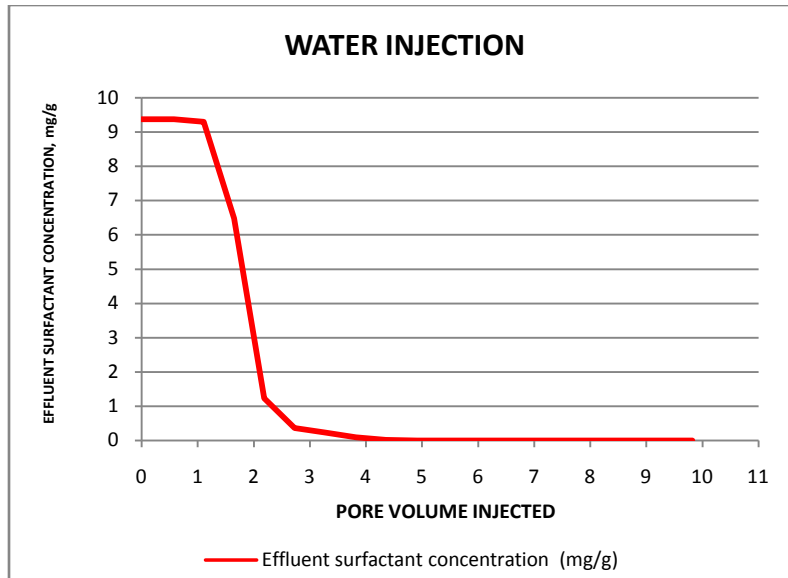

Figure 3.10 Effluent surfactant concentration vs. PV injected during water flooding in a treated core.

Table 3.5 Effluent samples of treated Berea core plug during water flooding 2

PV injected	Pressure drop (mbar)	Q (ml/min)	Sw (frac)	ro (ohm)
9.8	10.64	0.1	1.00	76.9

4. *n-Decane flooding 1:*

During *n-Decane flooding 1*, collected effluent samples are transparent. By using equation 1.5, *n* is calculated which is a value greater than 5 which means that treated core plug is **strong oil wet**. Table 3.6 shows calculations obtained during flooding.

Table 3.6 Effluent samples of treated Berea core plug during *n-Decane flooding 1*

Swi (frac)	rt (ohm)	n	kro
0.21	604300	5.78	0.29

After n-Decane flooding 1, treated Berea core plug is cleaned by injecting MeOH. Then, N<sub>2</sub> is injected at 60 °C to dry the core plug and get the initial conditions. Later, temperature is decreased to room temperature. Finally, absolute permeability is measured by injecting formation water at different rates and applying Darcy's law equation:  $k_{abs} = 653 \text{ md}$ .

5. *n-Decane flooding 2:*

In n-Decane flooding 2 is observed that the treated Berea core plug remains ***strong oil wet*** although it was previously cleaned and dried as shown in Table 3.7

Table 3.7 Effluent samples of treated Berea core plug during n-Decane flooding 2

Swi (frac)	rt (ohm)	n
0.32	147300	6.63

ii. *Untreated core plug*

1. *Water flooding 1:*

During this flooding all samples are transparent; and pH values are around 5.2 which are close to the formation water (pH = 5.3). Table 3.8 shows the main parameters in this flooding.

Table 3.8 Effluent samples of untreated Berea core plug during water flooding 1

PV injected	Pressure drop (mbar)	Q (ml/min)	Sw (frac)	ro (ohm)
10.7	20	0.5	1.00	94.0

## 2. Surfactant flooding:

Collected effluent samples are transparent. Breakthrough is around 3.7 PV where surfactant concentration keeps constant (9.36 mg/g) as depicted in Figure 3.11.

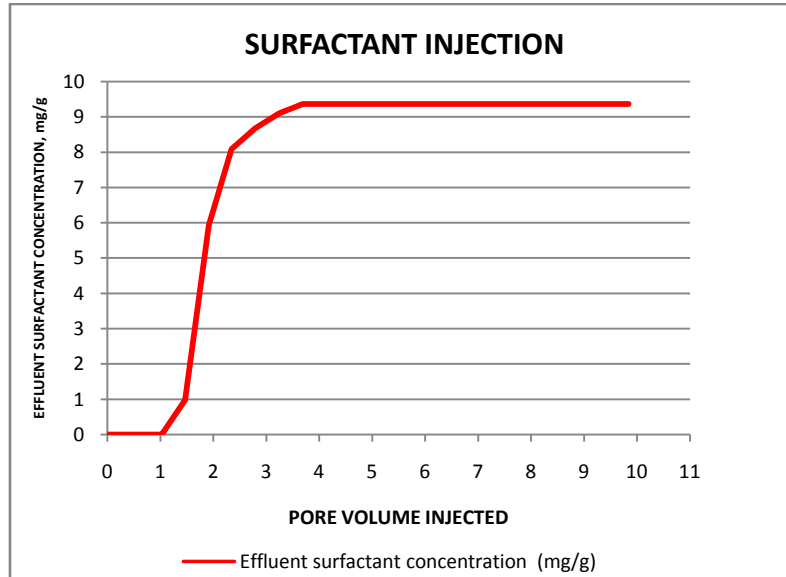

Figure 3.11 Effluent surfactant concentration vs. PV injected during surfactant flooding in an untreated core

## 3. Water flooding 2:

Figure 3.12 shows a sharply decrease in the concentration from 9.34 mg/g (surfactant) to 0 when 3.8 PV of formation water have been injected. Moreover, effluent samples are transparent. Table 3.9 depicts the main parameters in this flooding.

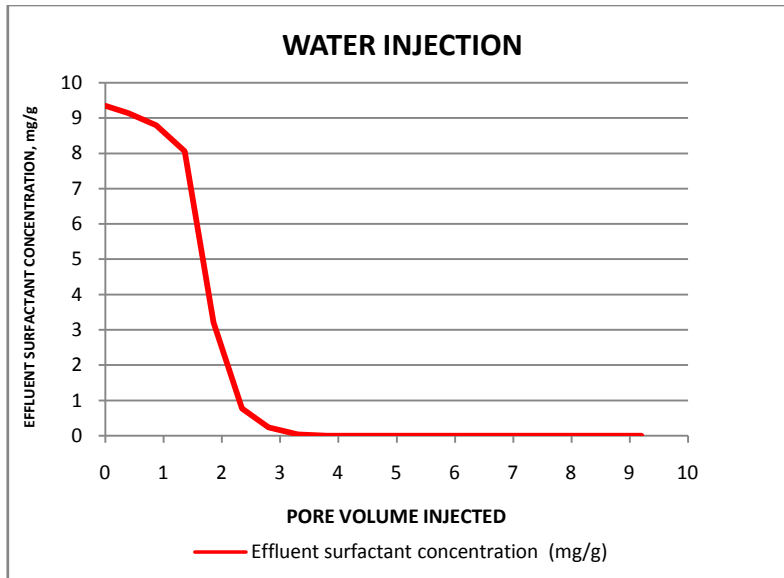

Figure 3.12 Effluent surfactant concentration vs. PV injected during water flooding in an untreated core.

Table 3.9 Effluent samples of untreated Berea core plug during water flooding 2

PV injected	Pressure drop (mbar)	Q (ml/min)	kabs (mD)	Sw (frac)	ro (ohm)
9.2	12.4	0.2	571	1.00	71.4

4. *n-Decane flooding:*

Effluent samples are transparent during *n-Decane* flooding. Additionally, resistivity is measured when core plug is partially saturated with formation water ( $r_t$ ), and applying equation 1.5,  $n$  is around 2 which means that is ***strong water wet***. Table 3.10 shows calculations obtained during flooding

Table 3.10 Effluent samples of untreated Berea core plug during *n-Decane* flooding

Swi (frac)	$r_t$ (ohm)	$n$
0.31	949	1.96

A summary of the two experiments is shown in Table 3.11

Table 3.11 Summary of the stability test

<b>Flooding</b>	<b>Treated (3.0 % wt Quilon L)</b>	<b>Untreated</b>
WF 1	- Yellow particles on effluent samples - pH increases up to 5.3 (pH of FW)	- Clean effluent samples - pH keeps constant → 5.3 (pH of FW)
SF	- Yellow particles on effluent samples - Breakthrough time: 4.8 PV	- Clean effluent samples - Breakthrough time: 3.7 PV
WF 2	- Yellow particles on effluent samples - $ro = 77 \Omega$	- Clean effluent samples - $ro = 71 \Omega$
n-Decane 1	- Clean effluent samples - $Swi = 0.21$ and $rt = 604300 \Omega$ - $n = 5.8 \rightarrow$ strong oil wet	- Clean effluent samples - $Swi = 0.31$ and $rt = 949 \Omega$ - $n = 2.0 \rightarrow$ strong water wet
Cleaning	- MeOH injection - N <sub>2</sub> injection at 60 C	-----
n-Decane 2	- $Swi = 0.32$ and $rt = 147300 \Omega$ - $n = 6.6 \rightarrow$ strong oil wet	-----

According to the results obtained in these 2 core plugs (treated and untreated), some issues have been observed as followed:

- Some yellow particles appeared in effluent samples which can be iron (Fe) released from Berea (Ferric oxide or ferrous oxide). These iron particles oxidize with time and then form yellow particles that will settle down on the bottom.
- During surfactant flooding, breakthrough in untreated core plug is earlier than the treated one (around 1 PV) which means that there will be a higher loss of surfactant (adsorption) in the treated core plug compared with the untreated one.
- As in the previous experiment (static experiment with Berea sample), it is observed that treated Berea core plug is strong oil wet whereas untreated one is strong water-wet.
- Quilon L treatment is not affected by surfactant or cleaning with MeOH in treated core plug because the wettability keeps as strong oil wet all time.

### 3.4 WATER FLOODING AND SURFACTANT FLOODING EXPERIMENTS

#### 3.4.1 Homogeneous treatment (Modification of wettability before drainage)

In this experiment, 4 Berea core plugs have been chosen for flooding experiments. The temperature is 38 °C, except for core plug 4 which is at 25 °C.

Table 3.12 Initial condition of core plugs

Core	Quilon L (% wt)	Swi (frac)	kabs (mD)	ko (mD)	ro (ohm)	rt (ohm)	n	Comment
3	0.0	0.094	610	289	60.0	3920	1.8	Strongly water wet
4	0.1	0.162	629	789	68.5	5820	2.4	Slightly water wet
5	1.0	0.210	673	317	67.8	29880	3.9	Preferentially oil wet
6	3.0	0.197	723	417	59.4	228400	5.1	Strongly oil wet

As it is seen in Table 3.12, **n** is proportional to Quilon L concentration (**% wt**) changing wettability of Berea from strong water wet ( $n = 2$ ) in an untreated core plug to strong oil wet ( $n = 5$ ) in a treated core plug.

#### i. **Water flooding:**

Core 3 (untreated core) and core 4 (Quilon L 0.1 % wt) experimental data are shown in Figures 3.13 and 3.14, respectively. As it is observed in these figures, after breakthrough,  $S_o$  reduces slightly and then keeps constant or holds constant all time which means that rock is water wet. Also,  $k_{rw}$  has been calculated at end point:  $k_{rw} = 0.14$  (core 3) and  $k_{rw} = 0.25$  (core 4) which confirm that rocks are water wet. In order to determine the grade of water wettability, **n** values are calculated and compared which indicate that untreated core plug is **strong water wet** and core plug with Quilon L 0.1 % wt. is **slightly water wet**.

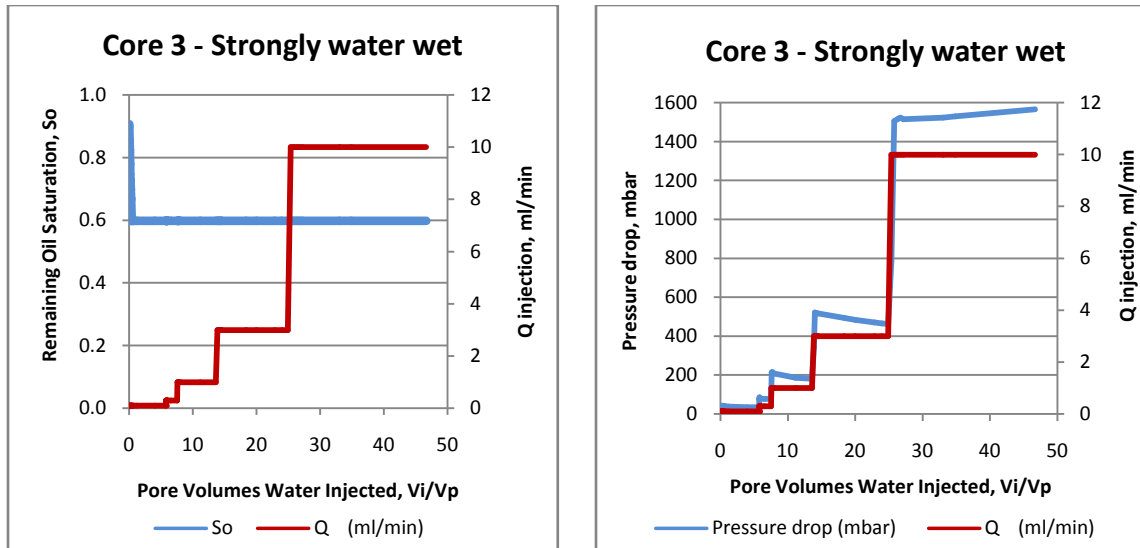

Figure 3.13 **Untreated core plug (core #3)**. During the water flooding a) Remaining Oil Saturation curve on left, b) Pressure drop behavior on the right

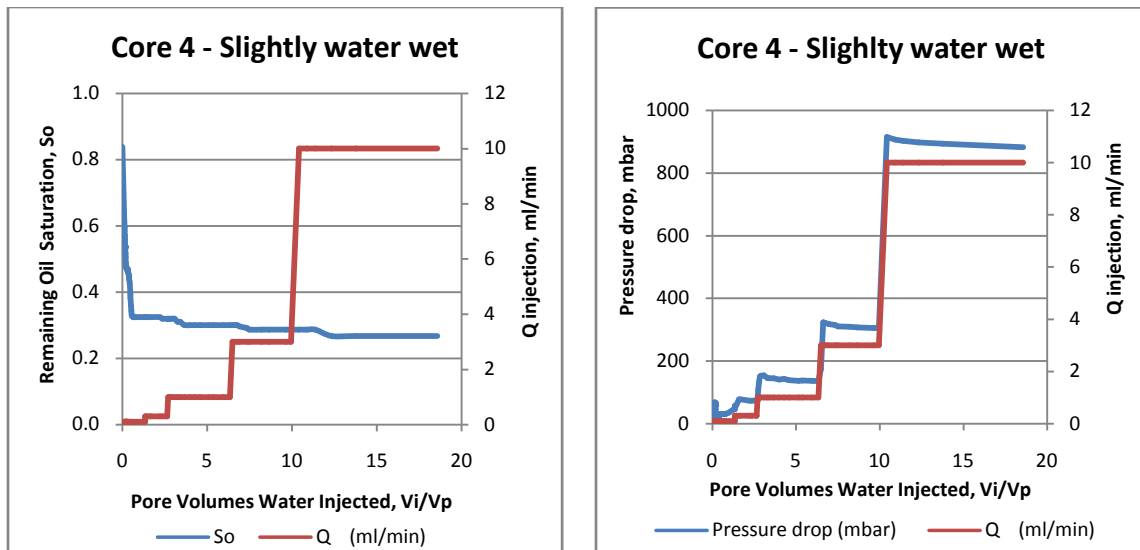

Figure 3.14 **Core plug with Quilon L 0.1 % wt (core #4)**. During the water flooding a) Remaining Oil Saturation curve on left, b) Pressure drop behavior on the right

Core 5 (Quilon L 1.0 % wt) and core 6 (Quilon L 3.0 % wt) experimental data are shown in Figures 3.15 and 3.16, respectively. Conversely, in these figures it is observed that after breakthrough,  $S_o$  continues decreasing for a little time and then it starts to keep constant which is related with oil wettability. Also,  $k_{rw}$  has been calculated at end point:  $k_{rw} = 0.60$  (core 5) and  $k_{rw} = 0.61$  (core 6). As before, the grade of oil wettability is

determined by calculating  $n$  values which concludes that core plug with Quilon L 1.0 % wt. is *preferential oil wet* whereas core plug with Quilon L 3.0 % wt. is *strong oil wet*.

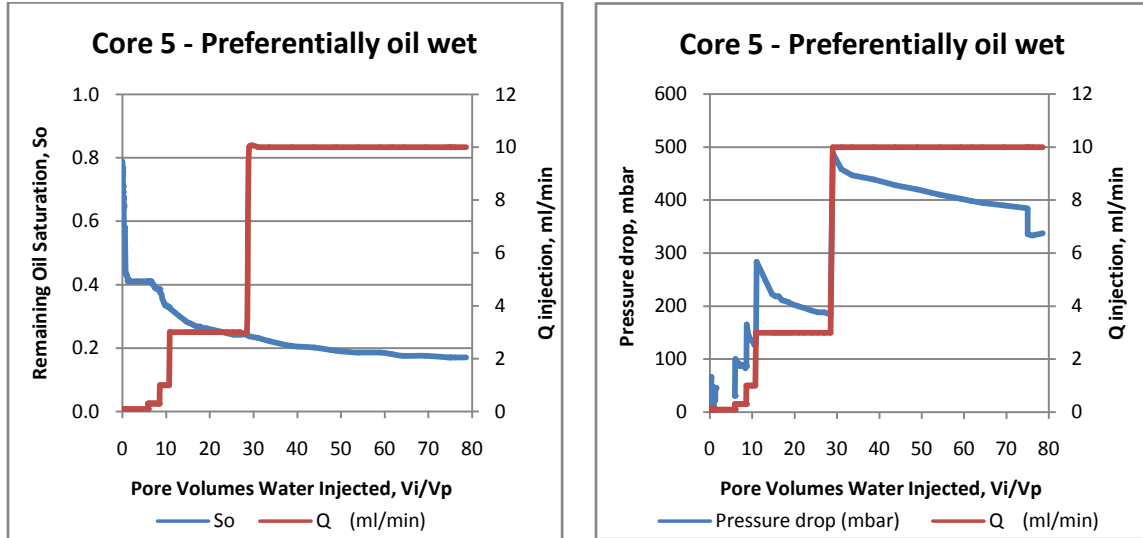

Figure 3.15 Core plug with Quilon L 1.0 % wt (core #5). During the water flooding a) Left, Remaining Oil Saturation curve, b) Right, Pressure drop across

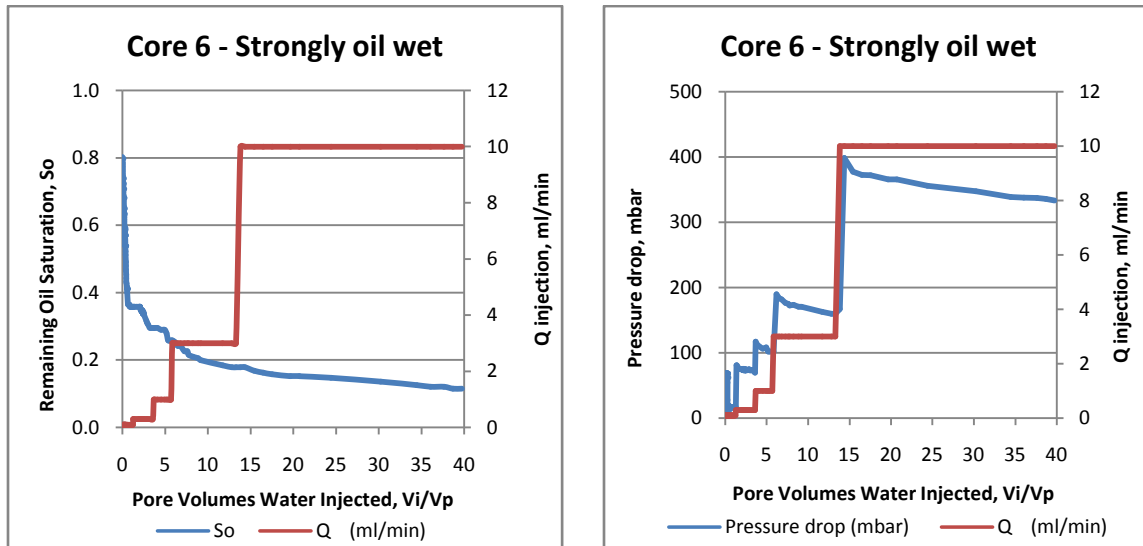

Figure 3.16 Core plug with Quilon L 3.0 % wt (core #6). During the water flooding a) Left, Remaining Oil Saturation curve, b) Right, Pressure drop across

Additionally, the largest reduction of  $S_o$  is obtained in the strongly oil wet rock (around 0.68) whereas the smallest reduction of  $S_o$  is in the strongly water wet (around 0.44).



Also, pressure drop is higher in strong water wet rocks because trapped oil is discontinuous (ganglia) and pressure needed to move forward is high, but it reduces when changing into strong oil wet rocks due to the oil is continuous.

ii. *Surfactant flooding:*

Once water flooding is finished, the highest  $S_o$  is in the core 3 (untreated core), and then it continues decreasing in core 4 (Quilon L 0.1 % wt) and core 5 (Quilon L 1.0 % wt) until reaching the lowest  $S_o$  in core 6 (Quilon L 3.0 % wt).

During surfactant flooding IFT is reduced between water and oil, and then trapped oil is moved forward. As it is observed, the highest reduction of  $S_o$  is obtained in the strongly water wet rock (Figures 3.17), then it starts to reduce (Figure 3.18 and 3.19) and finally, the smallest value it is obtained in the strongly oil wet (Figure 3.20). This phenomenon occurs because there is much oil trapped in the strong water wet than in strong oil wet after water flooding is finished.

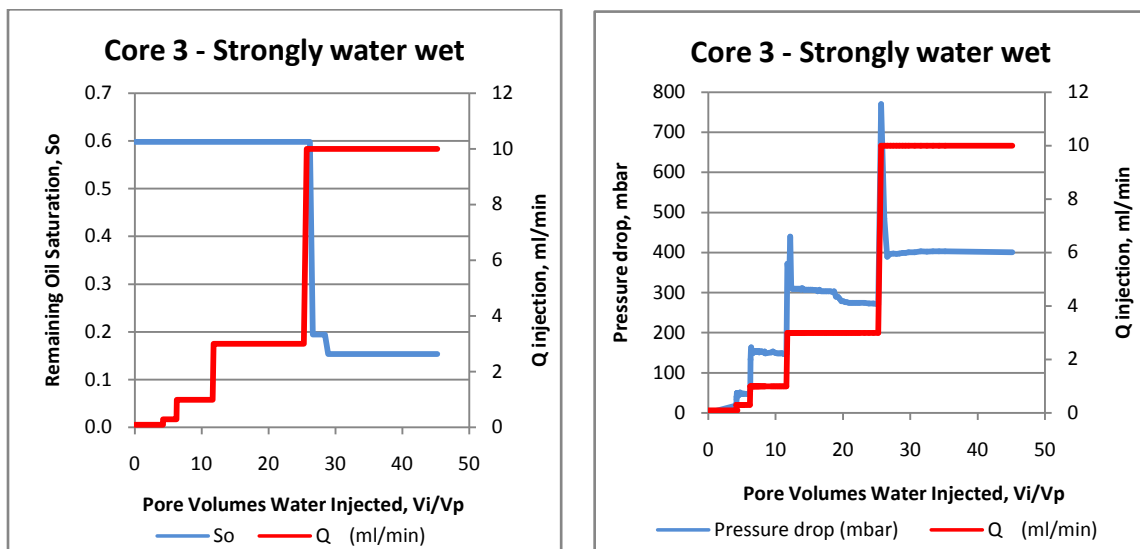

Figure 3.17 **Untreated core plug (Core #3)**. During surfactant flooding a) Left, Remaining Oil Saturation curve, b) Right, Pressure drop across

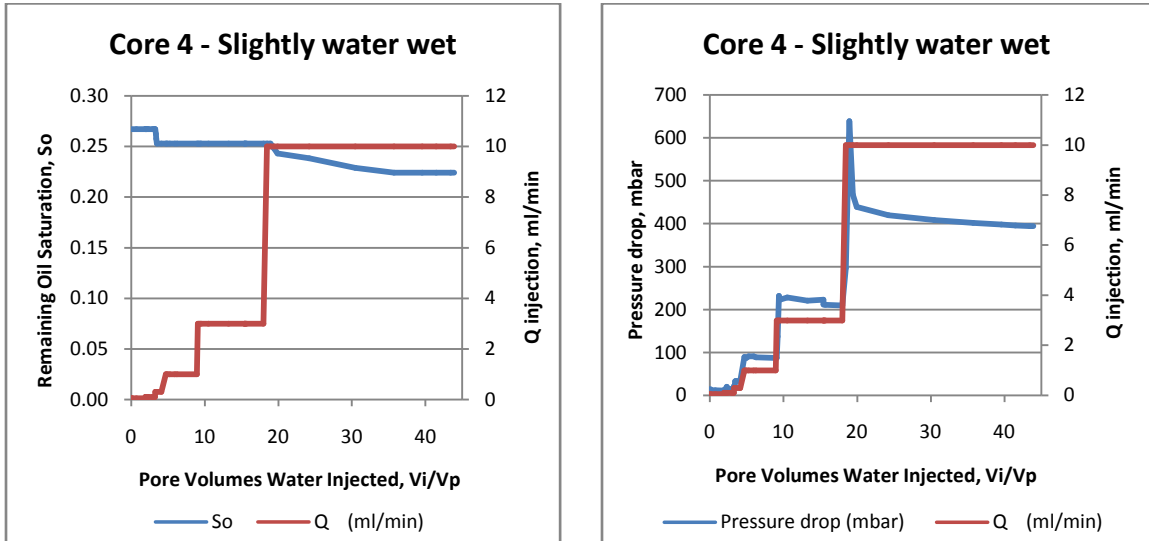

Figure 3.18 Core plug with Quilon L 0.1 % wt (Core #4). During surfactant flooding a) Left, Remaining Oil Saturation curve, b) Right, Pressure drop across

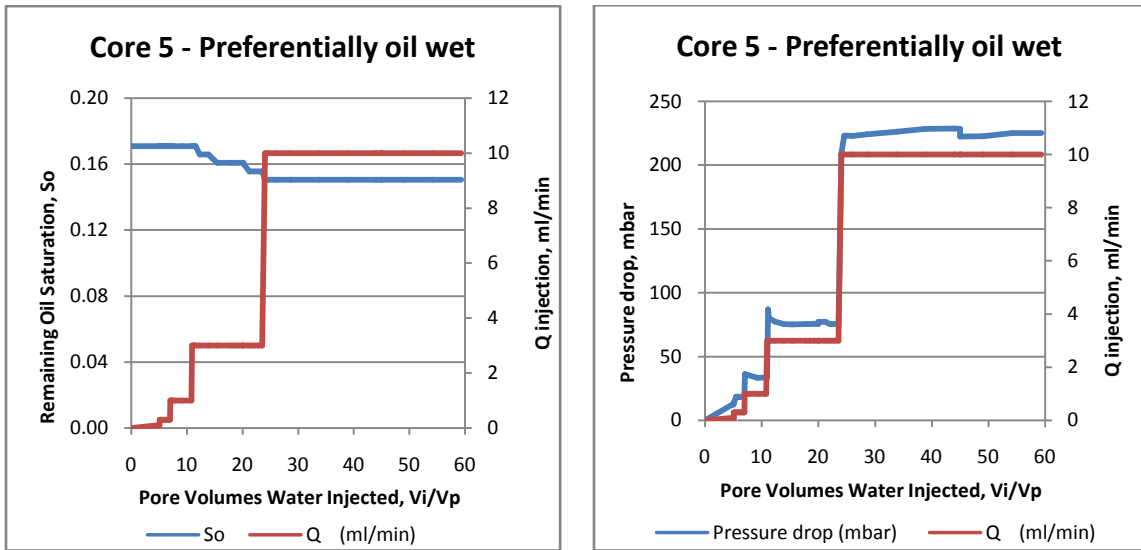

Figure 3.19 Core plug with Quilon L 1.0 % wt (Core #5). During surfactant flooding a) Left, Remaining Oil Saturation curve, b) Right, Pressure drop across

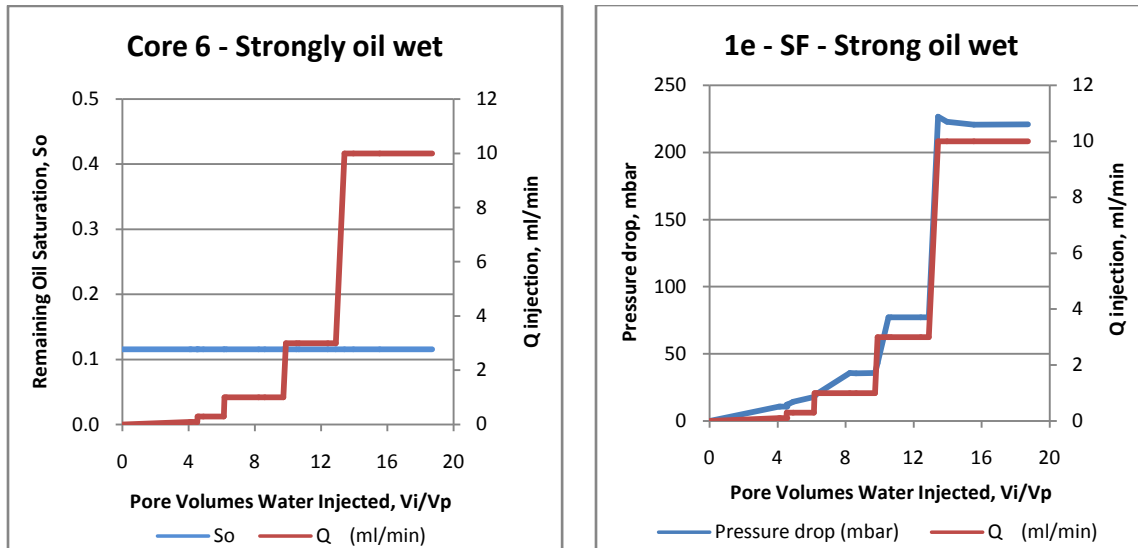

Figure 3.20 Core plug with Quilon L 3.0 % wt (Core #6). During surfactant flooding a) Left, Remaining Oil Saturation curve, b) Right, Pressure drop across

*Capillary number:* Figures 3.21 and 3.22 show a flat or slightly flat trend during water flooding as it is expected in water wet rocks, and then when surfactant flooding is implemented it starts to reduce sharply. Conversely, Figures 3.23 and 3.24 depicts a sharply decrease during water flooding, and then when surfactant flooding starts it keeps almost constant which is characteristic of oil wet rocks.

Furthermore, in 4 cases, capillary number ranges from  $1 * 10^{-8}$  to  $10^{-6}$  in water flooding, and from  $1 * 10^{-6}$  to  $10^{-4}$  in surfactant flooding.

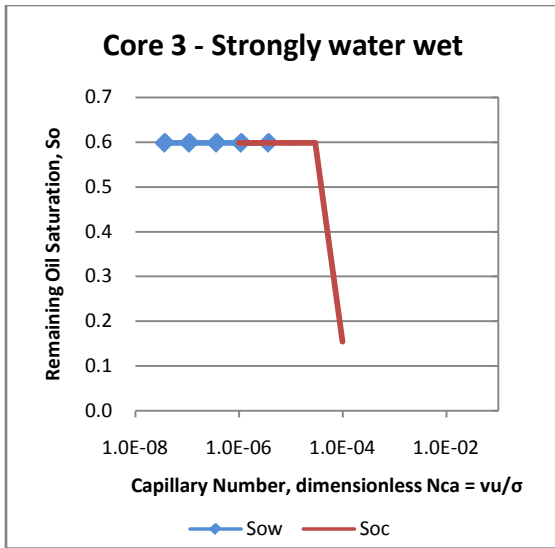

Figure 3.21 CDC for an untreated core plug

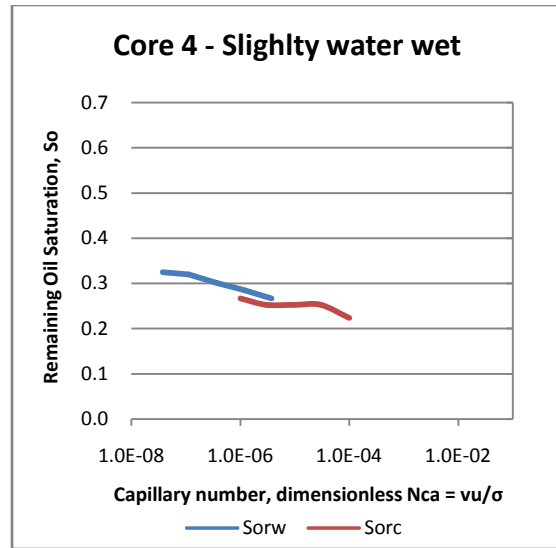

Figure 3.22 CDC for a core plug with Quilon L 0.1 % wt

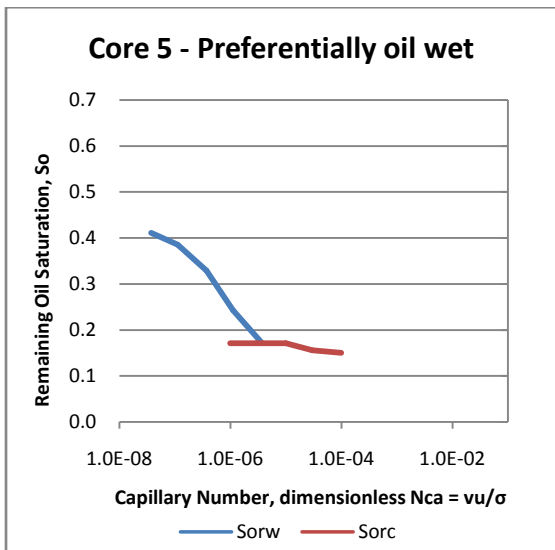

Figure 3.23 CDC for a core plug with Quilon L 1.0 % wt

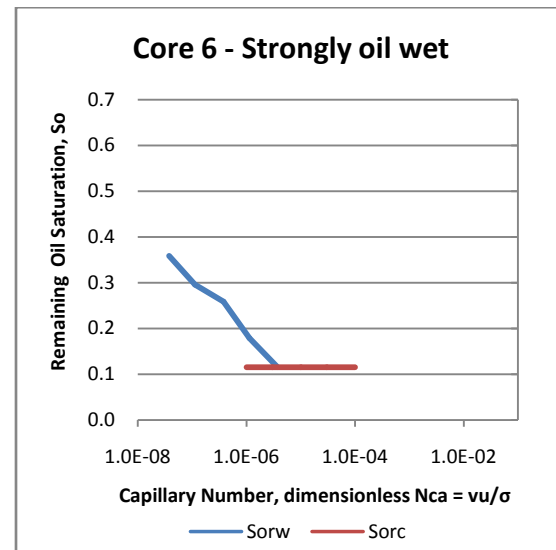

Figure 3.24 CDC for a core plug with Quilon L 3.0 % wt.

iii. *n-Decane flooding:*

Figure 3.25 (core 3) shows that after breakthrough,  $S_w$  continues decreasing slightly which means that is *water wet rock*. Conversely, in Figure 3.26 (core 5),  $S_w$  keeps almost flat after breakthrough which is interpreted as *oil wet rock*. Consequently, there is no

change in wettability in oil- and water-wet systems after water and surfactant flooding have been implemented (final and initial conditions are the same).

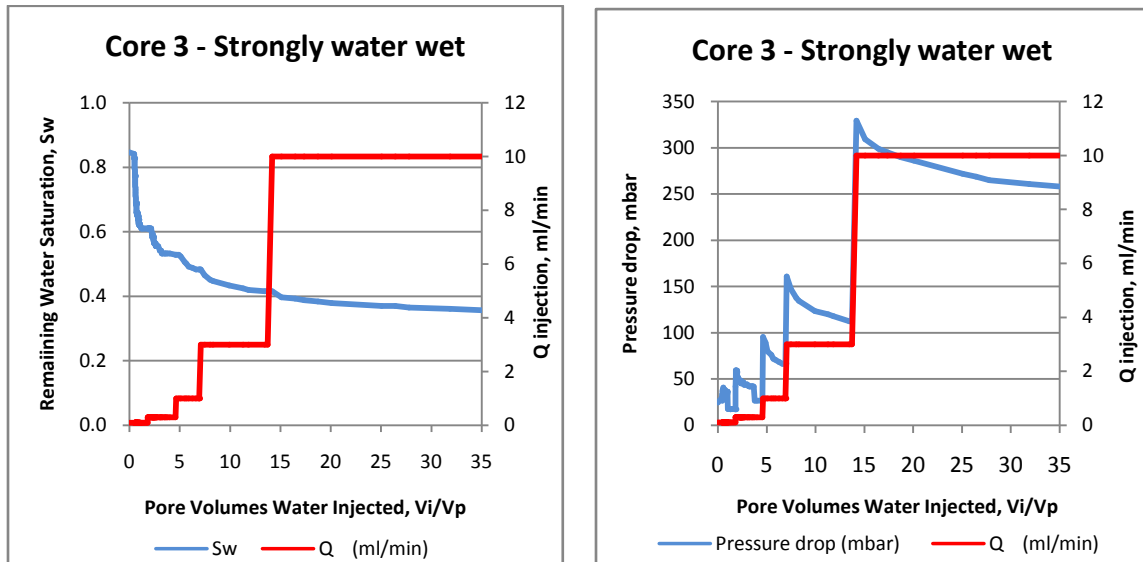

Figure 3.25 **Untreated core plug (Core #3)**. During the n-Decane flooding a) Left, Remaining Oil Saturation curve, b) Right, Pressure drop across

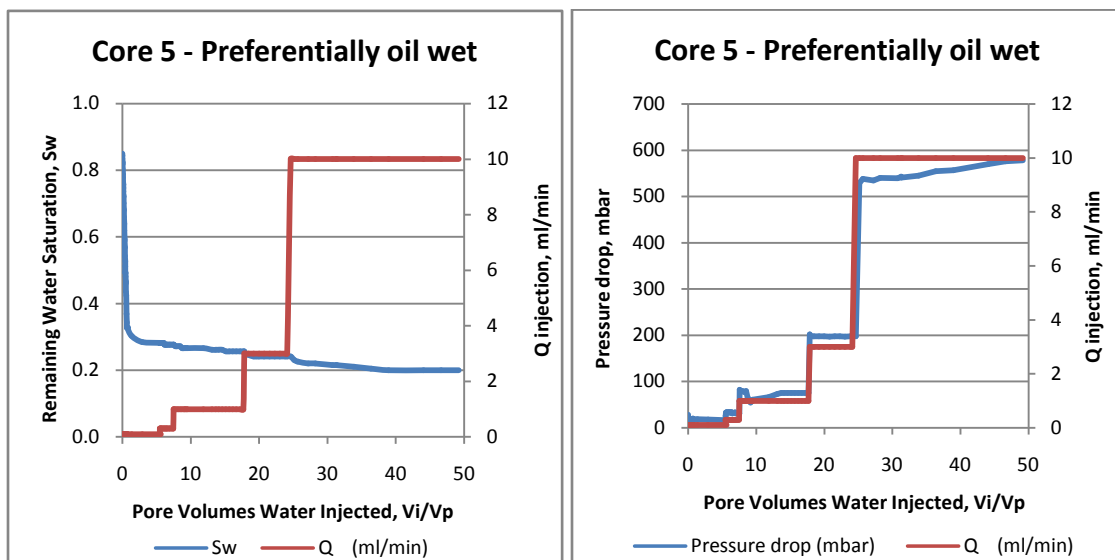

Figure 3.26 **Core plug with Quilon L 1.0 % wt (Core #5)**. During the n-Decane flooding a) Left, Remaining Oil Saturation curve, b) Right, Pressure drop across

A summary of the final results after flooding is shown in Table 3.13:

Table 3.13 Results of homogeneous wettability after flooding

Core	Quilon L (% wt)	Initial conditions			Water flooding			Surfactant flooding		n-Decane flooding	
		ko (mD)	Swi (frac)	Sor (frac)	kw (mD)	krw (frac)	Sorw (frac)	krw (frac)	Sorc (frac)	ko (mD)	Swi (frac)
3	0.0	289	0.09	0.91	87	0.14	0.60	0.55	0.15	281	0.36
4	0.1	789	0.16	0.84	155	0.25	0.27	0.55	0.22	-	-
5	1.0	317	0.21	0.79	403	0.60	0.17	0.90	0.15	118	0.200
6	3.0	417	0.20	0.80	442	0.61	0.12	0.86	0.12	-	-

### 3.4.2 Heterogeneous treatment (Modification of wettability after drainage to Swi)

In this experiment, 3 Berea core plugs have been altered to mixed wet rocks by injecting Quilon L solution (Quilon L diluted in n-Decane). Initial conditions of mixed wet core plugs are shown in Table 3.14

Table 3.14 Initial conditions of mixed core plugs

Core	Quilon L (3 % wt)	Aging	Swi (frac)	ro (ohm)	rt (ohm)	n	Comment
7	Yes	Yes	0.01	65	175000	1.8	Mixed wet
8	Yes	No	0.13	61	66700	3.4	Mixed wet
9	Yes	No	0.16	104	83000	3.7	Mixed wet

#### i. Water flooding:

As it is seen in Figures 3.27, 3.28 and 3.29, reduction in remaining oil saturation drops sharply to reach zero values as it continues increasing flowing rate which is characteristics of *mixed wet rocks* as it was expected according to Salathiel<sup>11</sup> model (strong oil wet in large pores and strong water wet in small pores). Another parameter that is observed in these type of rocks is that krw is greater than 0.60 (krw=1.15,

$k_{rw} = 0.95$  and  $k_{rw} = 0.70$  for cores 7, 8 and 9 respectively), and pressure drop across core plugs is low and quite similar to strong oil wet values.

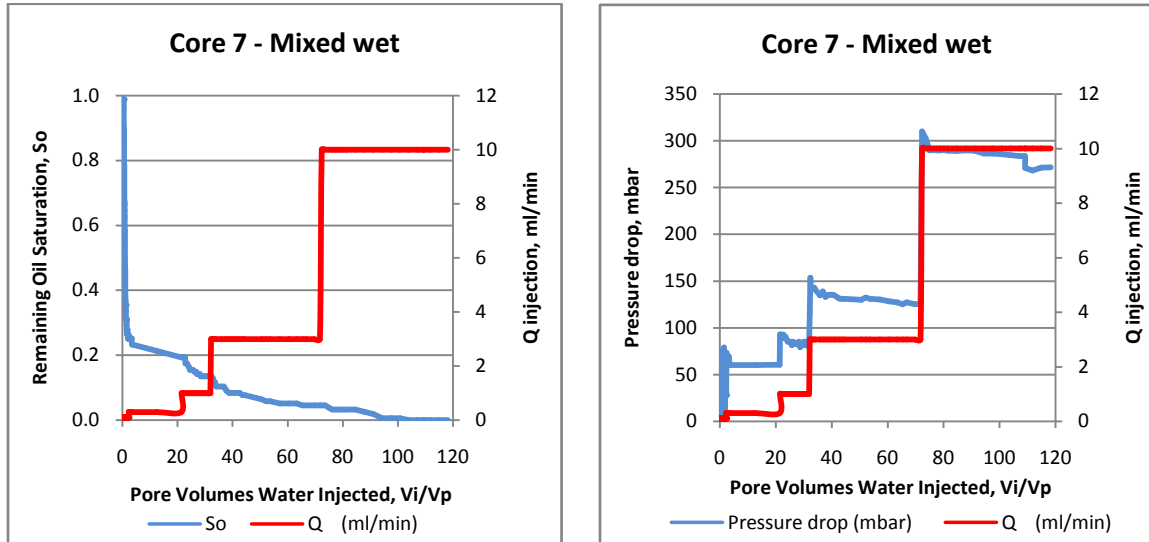

Figure 3.27 Core plug 7 during water flooding a) Left, Remaining Oil Saturation curve, b) Right, Pressure drop across

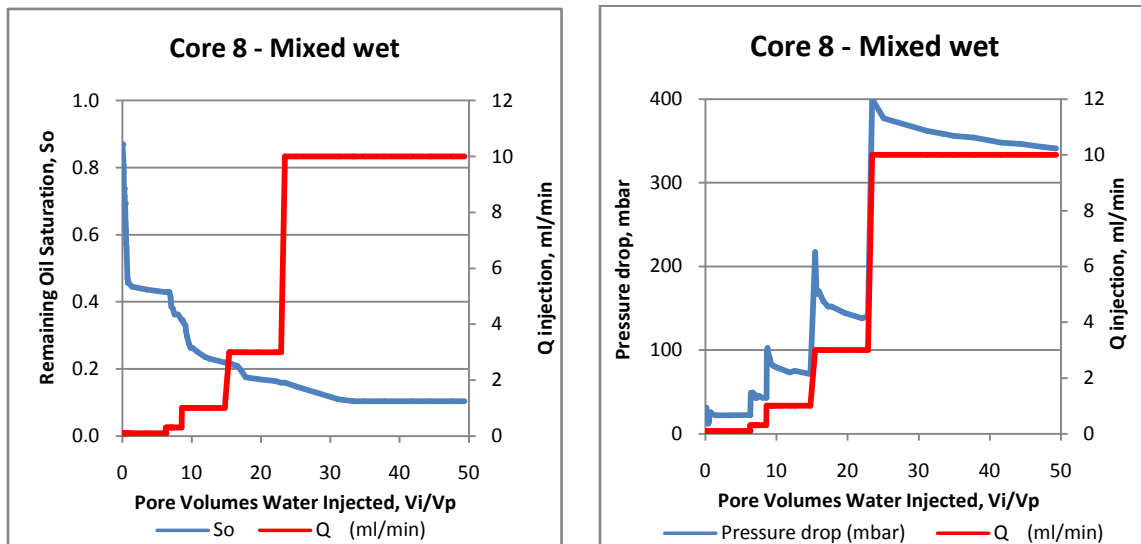

Figure 3.28 Core plug 8 during water flooding a) Left, Remaining Oil Saturation curve, b) Right, Pressure drop across

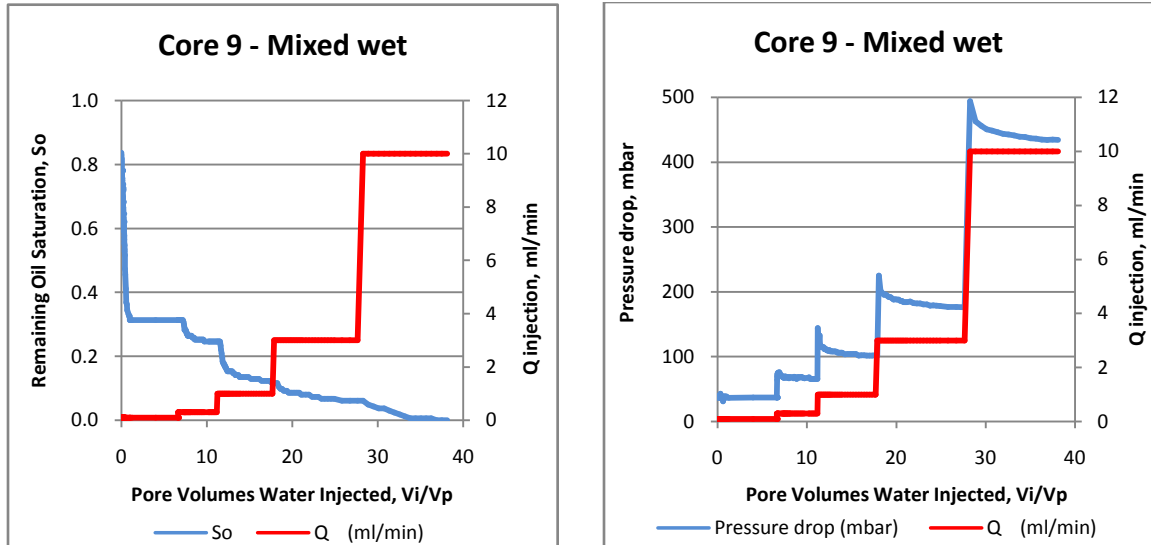

Figure 3.29 Core plug 9 during water flooding a) Left, Remaining Oil Saturation curve, b) Right, Pressure drop across

ii. *Surfactant flooding:*

Figures 3.30, 3.31 and 3.32 show that implemented surfactant flooding at different flowing rates in mixed wet rocks causes no effect in oil recovery because remaining oil saturation is very low or zero after water flooding.

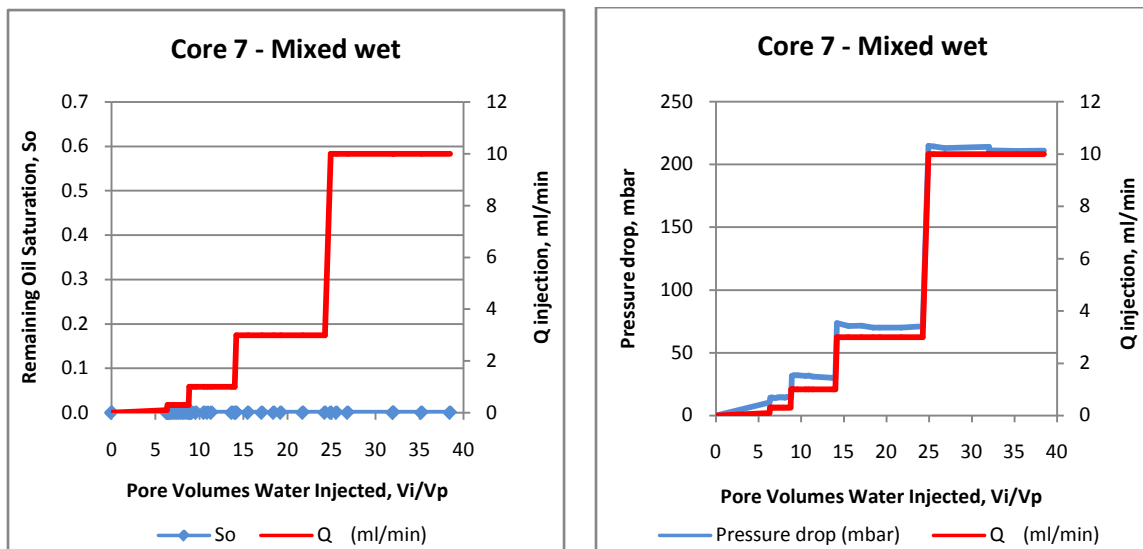

Figure 3.30 Core plug 7 during surfactant flooding a) Left, Remaining Oil Saturation curve, b) Right, Pressure drop across



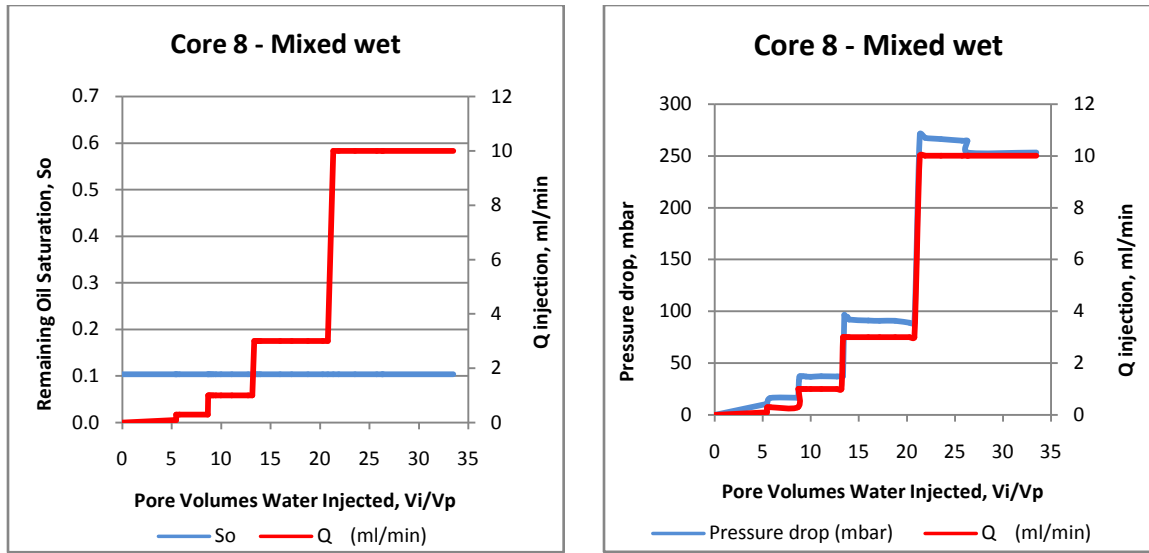

Figure 3.31 Core plug 8 during surfactant flooding a) Left, Remaining Oil Saturation curve, b) Right, Pressure drop across

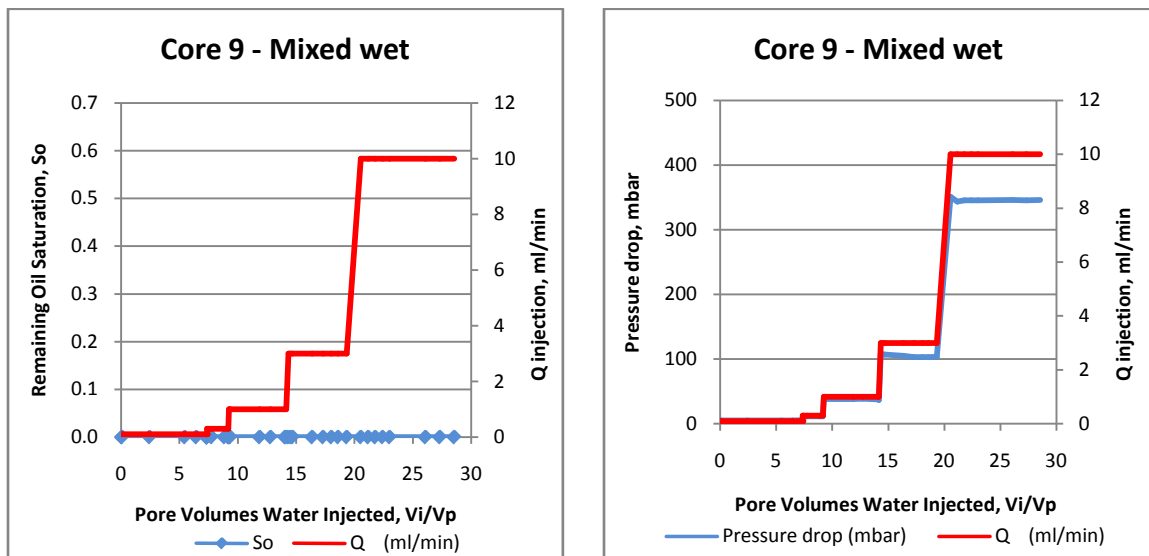

Figure 3.32 Core plug 9 during surfactant flooding a) Left, Remaining Oil Saturation curve, b) Right, Pressure drop across

*Capillary number:* There is a similar behavior in the capillary number trend in the 3 mixed-wet core plugs as shown in Figure 3.33 (left, right and bottom). Remaining oil saturation drops sharply to zero or very low value during water flooding and then it

remains constant. Also, typical capillary number ranges from  $1 * 10^{-8}$  to  $10^{-6}$  in water flooding, and from  $1 * 10^{-6}$  to  $10^{-4}$  in surfactant flooding as in the previous studies (strongly oil- and water- wet rocks).

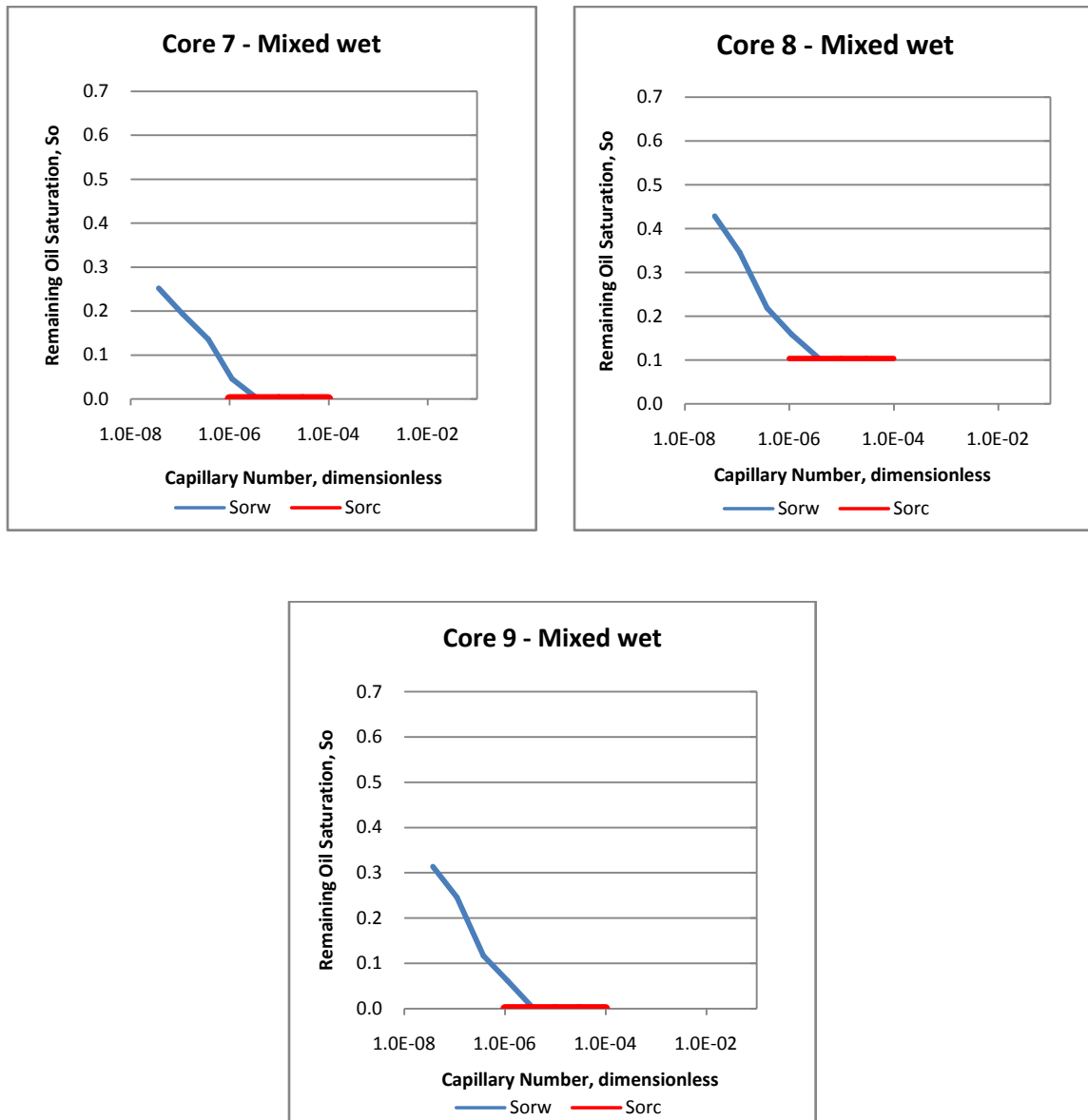

Figure 3.33 Capillary Desaturation Curve, CDC. a ) Core 7 on the left, b) Core 8 on the Right, c) Core 9 on the bottom

### 3. *n*-Decane flooding:

Figures 3.34, 3.35 and 3.36 show that after water and surfactant flooding methods have been applied to mixed wet rocks, the rocks did not change wettability because the trend after breakthrough is almost flat and quite similar to oil wet rocks (mixed wet<sup>11</sup>).

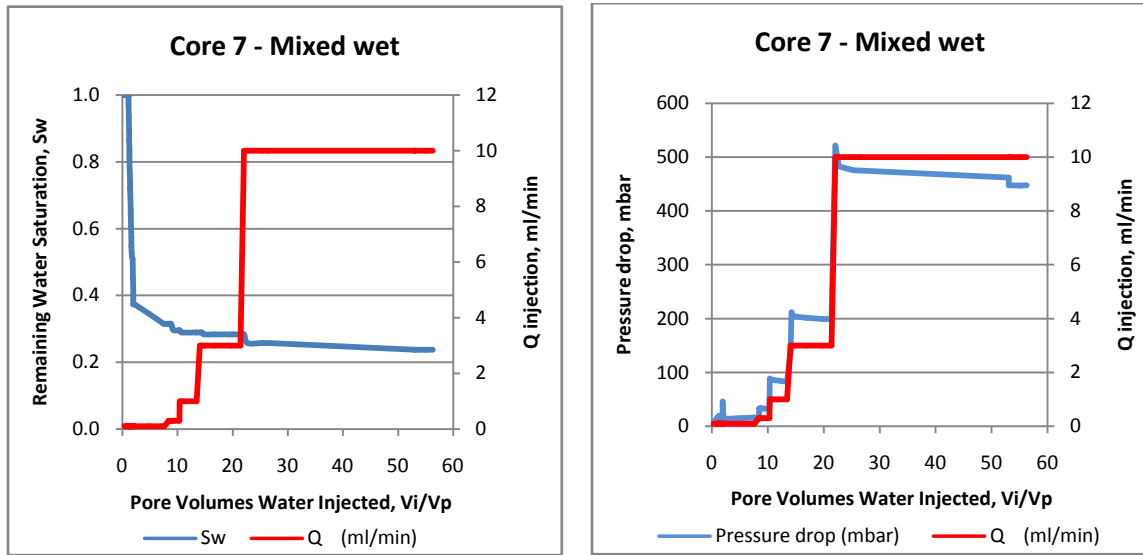

Figure 3.34 Core plug 7 during *n*-Decane flooding a) Left, Remaining Oil Saturation curve, b) Right, Pressure drop across

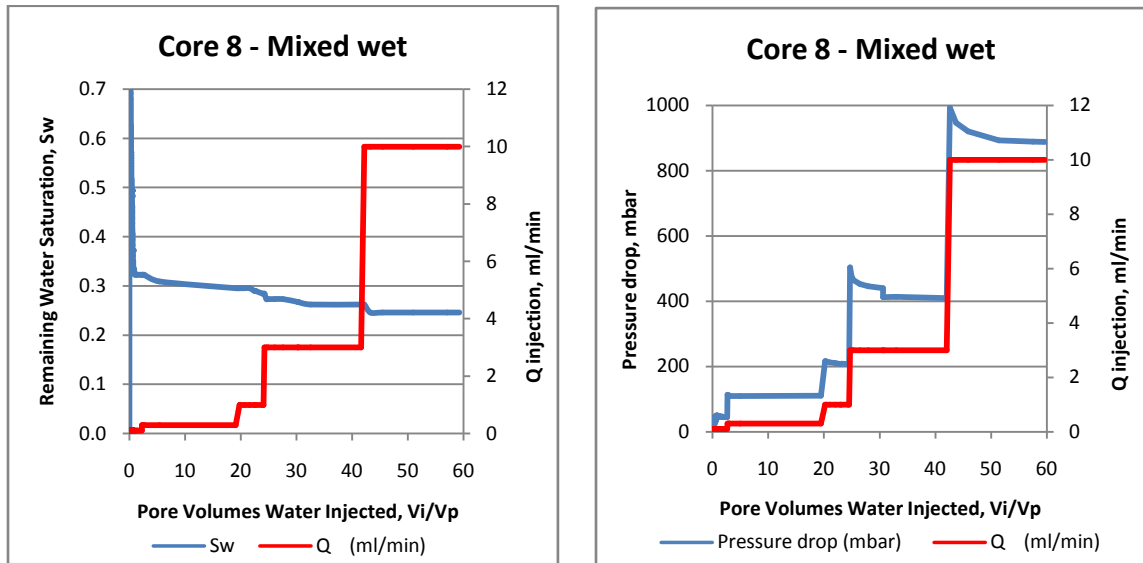

Figure 3.35 Core plug 8 during *n*-Decane flooding a) Left, Remaining Oil Saturation curve, b) Right, Pressure drop across

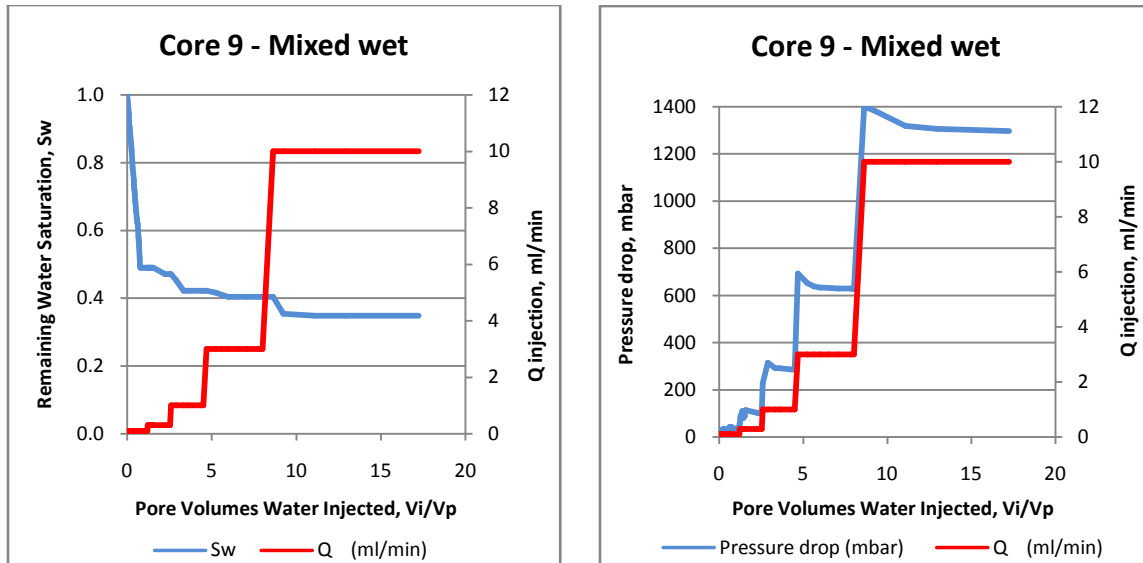

Figure 3.36 Core plug 9 during n-Decane flooding a) Left, Remaining Oil Saturation curve, b) Right, Pressure drop across

A summary of final conditions after water and surfactant flooding is shown in Table 3.15

Table 3.15 Final conditions of mixed core plugs

Core	Initial Conditions		Water flooding			Surfactant flooding		n-Decane flooding	
	$S_{wi}$ (frac)	$S_{or}$ (frac)	$k_w$ (mD)	$k_{rw}$ (frac)	$S_{orw}$ (frac)	$k_{rw}$ (frac)	$S_{orc}$ (frac)	$k_{ro}$ (mD)	$S_{wi}$ (frac)
7	0.01	0.99	497	1.15	0.00	1.34	0.00	0.35	0.24
8	0.13	0.87	398	0.95	0.10	1.23	0.10	0.18	0.25
9	0.16	0.84	312	0.68	0.00	0.88	0.00	0.11	0.35

## ***CONCLUSIONS***

- In the static experiments, untreated minerals like calcite, quartz and kaolinite that are present in Berea sandstone show a water-wet surface, whereas when they are treated with **3.0 wt %** Quilon L solution, all of them change into an oil-wet surface.
- In the stability test, Quilon L treatment is not affected by surfactant or cleaning with MeOH in treated core plug because the wettability keeps as strongly oil wet all time. Loss of surfactant is greater in treated core plug (with 3.0 wt % Quilon L solution) compared with the untreated core plug.
- Reduction of remaining oil saturation,  $S_o$ , in water flooding is less effective for strong water wet rocks than strong oil wet rocks, but conversely in surfactant flooding is more effective for strong water wet rocks than strong oil wet rocks.
- Archie exponent,  $n$ , obtained in experiments is 2 for strong water wet, more than 5.2 for strong oil wet and around 3.8 for mixed wet rocks as it was expected according to several studies.
- In mixed wet rocks, water flooding is very effective to reduce remaining oil saturation to a low value or close to zero as it was expected according to Salathiel <sup>11</sup> model. Therefore, it is not necessary to implement surfactant flooding.
- Pressure drop during water flooding in mixed wet rocks is quite similar to strong oil wet, but very low compared with strong water wet.
- During water flooding, capillary number trend is flat in strongly water wet rocks which mean that there is no oil recovery ( $S_o$  keeps constant). Conversely, there is an inclination in strongly oil- and mixed-wet rocks ( $S_o$  reduces). This phenomenon occurs at lower  $N_{ca}$  (typically ranges from  $1 * 10^{-8}$  to  $10^{-6}$ ).

- In surfactant flooding, the effect is opposite as in water flooding. Capillary number trend is inclined in strongly water wet (So decreases sharply). Nevertheless, Nca keeps flat in strongly oil wet or mixed rocks systems. This phenomenon occurs at higher Nca (typically ranges from  $1 \cdot 10^{-6}$  to  $10^{-4}$ ).
- Surfactant used in the experiments did not affect the Quilon L treatment in core plugs.

## ***REFERENCES***

1. Green, Don W. and Willhite, G. Paul: "Enhanced Oil Recovery", SPE Textbook Vol. 6, Chapter 7, Richardson, TX (1998)
2. Whillhite, G. P.: "Water flooding", SPE Textbook Series, Vol. 3, Chapter 1 and 2, Richardson, TX (1986).
3. Wade, J. E.: "Some Practical Aspects of Water flooding", Long Beach, California (1971)
4. Alvarado, V. and Manrique, E.: "Enhanced Oil Recovery", Textbook, Chapter 2, USA (2010)
5. Kyte, R. J. and Rapoport, L. A.: "Linear Water Flood Behavior and End Effects in Water-Wet Porous Media", SPE 929-G, Dallas, TX (Oct-57)
6. Richardson, J. G. and Perkins, F. M.: "A laboratory investigation of the effect of Rate on Recovery of Oil by Water Flooding", SPE 693-G, Los Angeles, California (Oct-56)
7. Dong, H., Hong Y. and Rui, W.: "The Effect of Wettability on Oil Recovery of Alkaline/Surfactant/Polymer Flooding", SPE 102564, San Antonio, TX (Sep-06)
8. Maudgalya, S., McInerney, M. J., Knapp, R. M., Nagle, D. P. and Folmsbee, M.J., "Tertiary Oil Recovery With microbial Biosurfactant Treatment of Low-Permeability Berea Sandstone Cores", SPE 94213, Oklahoma, USA 2005
9. Jerauld, G. R. and Rathmell, J.J.: "Wettability and Relative Permeability of Prudhoe Bay: A Case Study in Mixed-Wet Reservoirs", SPE 28576 Reservoir Engineering, New Orleans (Feb-97)
10. Anderson, William G.: "Wettability Literature Survey-Part 1: Rock/Oil/Brine Interactions and the Effects of Core Handling on Wettability", SPE 13932, Pages 1125 – 1127 (Oct-86)
11. Salathiel, R. A.: "Oil Recovery by Surface Film Drainage in Mixed-Wettability Rocks", Journal of Petroleum Technology, Pages 1216-1218 (Oct-73)
12. Anderson, William G.: "Wettability Literature Survey - Part 2: Wettability Measurement", SPE 13933, Pages 1246 - 1258 (Nov-86)

13. Amott, Earl: "Observations Relating to the Wettability of Porous Rock", SPE 1167-G, Los Angeles, California, Pages 156-157 (Oct-58)
14. Donaldson, Erle C., Thomas, Rex D. and Lorenz, Philip B.: "Wettability Determination and Its Effect on Recovery Efficiency", SPE 2338, Pages 13-14, Bartlesville, Okla. (Mar-69)
15. Sondena, E., Bratteli, F. and Normann, H. P., and Kollveit, K.: "The Effect of Reservoir Conditions and Wettability on Electrical Resistivity", SPE 22991, Pages 409-411, Perth, Western Australia (Nov-91).
16. Sanyal, S. K., Marsden, S. S. and Ramey, H.J.: "The Effect of Temperature on Electrical Resistivity of Porous Media", SPE 1973-vXIVn2a2, Pages 12-14 and 23, California (Mar-73).
17. Morgan, W. B. and Pirson, S. J.: "The Effect of Fractional Wettability on the Archie Saturation Exponent", SPWLA 1964-B, Page 10, Midland, TX (May-64)
18. Lewis, M. G., Sharma, M. M. and Dunlap, H. F.: "Wettability and Stress Effects on Saturation and Cementation Exponents", SPWLA 1988-K, (1988)
19. Craig, F.: "The Reservoir Engineering Aspects of Water flooding", SPE, Chapter 2, Richardson, (1971)
20. Morrow, Norman R.: "Interfacial Phenomena in Petroleum Recovery", Volume 36, Pages 325-326 (1991)
21. Tabrizy, Vahid Alipour: "The Role of Wettability in Immiscible Gas Assisted Gravity Drainage (GAGD) Process", Thesis at the University of Calgary, Pages 43-44, Calgary (Jan-09)
22. Maini, B. B., Ionescu, E. and Batycky, J.P.: "Miscible displacement of residual oil – effect of wettability on dispersion in porous media", The Journal of Canadian Petroleum Technology, JCPT86-03-03, Page 41 (Appendix), Montreal, Canada (May-86)
23. Lewis, M. G., Sharma, M. M., Dunlap, H.F. and Dorfman, M.H.: "Techniques for Measuring the Electrical Properties of Sandstone Cores", SPE 18178, Pages 697-698, Houston, TX (Oct-88)



24. Menezes, J. L. and Sharma, M. M.: "Wettability Alteration Due to Interactions with Oil-Based Muds and Mud Components", SPE 18162, Page 558, Houston, TX (Oct-88)
25. Fleury, M. and Zarcone, C.: "Intermediate wettability by chemical treatment", Journal of Petroleum Science & Engineering 24, Page 124 (1999)
26. Rosen, Milton J.: "Surfactants and Interfacial Phenomena", Textbook Third Edition, (2004)
27. Schramm, L., Stasiuk, E. and Marangoni, G.: "Surfactants and their applications", Annu. Rep. Prog. Chemistry Section C, Pages 15-18 (2003)
28. Nelson, R. C. and Pope, G. A.: "Phase Relationships in Chemical Flooding", SPE 6773, Pages 325-328, Denver (Oct-78)
29. Gale, W. W. and Sandvik, E. I.: "Tertiary Surfactant Flooding: Petroleum Sulfonate Composition Efficacy Studies", SPEJ, Pages 226-236 (Apr-82)
30. Nelson, R. C.: "Effect of Live Crude on Phase Behavior and Oil-Recovery Efficiency of Surfactant Flooding Systems", SPEJ (Jun-83)
31. Pope, G. A. *et al*: "The Effect of Several Polymers on the Phase Behavior of Micellar Fluids ", SPEJ (Dec-82)
32. Mwangi, Paulina: "An Experimental Study of Surfactant Enhanced Water flooding", Thesis, Pages 11-13, (Dec 10)
33. Dupont Company, Brochure of Quilon Chrome complexes, page 4.
34. Surfactant Material Data Sheet for WITCOLATE 7093, Akzo Nobel Surface Chemistry LLC
35. VWR International, n-Decane data sheet (Oct-03)
36. Schmitt, T. M.: "Analysis of Surfactants", Textbook Second Edition, Pages 83-100, Wyandotte, Michigan
37. Mohr's titration method brochure, Pages 1-2

# Appendix A

## **Titration of Surfactants**

A lot of methods have been studied depending on the nature of the surfactants (anionic, nonionic, cationic and amphoteric): one-phase titration, two-phase titration, etc. Nevertheless, according to Thomas M. Schmitt<sup>36</sup> the most useful methods for volumetric determination of ion surfactants are based on titration of a cationic surfactant with an anionic surfactant or the titration of an anionic surfactant with a cationic surfactant.

### *Two-phase titration*

It is based on a reaction between anionic surfactants and cations to form a neutralized ion pair. In a two phase system the ion pair is therefore extracted continually into the organic phase as it is formed.

### *Procedure*

A modification of the standard procedure proposed by Thomas M. Schmitt<sup>xx</sup> has been adapted for the present research:

1. First, weigh approximately 0.3 g from effluent samples (formation water with surfactant)
2. After, add 4.0 g of water-soluble cationic dye (methylene blue proposed by Epton method) and 1.5 g of chloroform.
3. Then, titrate with the benzethoniumchloride (Hyamine) and shake every time that titrant is added. The end point is given when the blue color of the phases are equal.
4. To calculate the concentration of surfactant, the following equation is used:

$$\text{Conc}_{(\text{mg/g})} = \left\{ \left[ \left( M_{\text{Hya}} * v_{\text{Hya}} - M_{\text{MB}} * m_{\text{MB}} * m_{\text{Chol}} \right) / \left( m_{\text{Chol}} + m_{\text{MB}} + m_{\text{samp}} + v_{\text{Hyam}} \right) \right] / m_{\text{samp}} \right\} * MW_{\text{Surfact}}$$

Where:

$m_{\text{samp}}$  = mass of fluid: formation water with surfactant (g)

$m_{\text{MB}}$  = mass of methylene blue (g)

$M_{\text{MB}}$  = 0.0002 g/mol (molecular weight of methylene blue)

$m_{\text{Chloroform}}$  = mass of chloroform (g)

$v_{\text{Hyamine}}$  = volume of hyamine (ml)

$M_{\text{Hyamine}}$  = 0.004 g/mol (molecular weight of hyamine)

## Appendix B

### Determination of Chloride Ion Concentration by Titration (Mohr's Method)<sup>37</sup>

Mohr's method is used to determine the chloride ion concentration of a solution (water sample) by titration with silver nitrate ( $\text{AgNO}_3$ ). As the silver nitrate is added to the solution, a silver chloride precipitation ( $\text{AgCl}$ ) is formed given by the following chemical reaction:



The end point of the titration occurs when all the chloride ions are precipitated. Then additional silver ions react with the chromate ions of the indicator, potassium chromate, to form a red-brown precipitate of silver chromate.

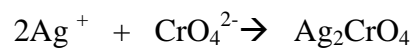

#### *Procedure*

1. Pipette 5 ml (around 5.6 g) of formation water sample into a conical flask, and add 2 drops of potassium chromate indicator ( $\text{K}_2\text{CrO}_4$ ). A faint lemon-yellow solution is obtained as shown in Figure 1.



Figure 1 Formation water sample + potassium chromate indicator<sup>37</sup>

2. Titrate the solution with silver nitrate ( $\text{AgNO}_3$ ). Silver chloride ( $\text{AgCl}$ ) will form as a white precipitation at the beginning, and then by continuing titration, it will change into a red-brown color which is the end point as shown in Figure 2.



Figure 2 End point of titration<sup>37</sup>

Then, the following equations are used to calculate the accessible volume of water:

$$\text{Cl}^- = 0.1 * \text{AgNO}_3 \text{ (ml)} / V_{\text{sample}} \text{ (ml)}$$

$$V_{\text{W}} = [(C_{\text{Cl}^- \text{ Sample}} - C_{\text{Cl}^- \text{ NO}_3\text{FW}}) / C_{\text{Cl}^- \text{ FW}}] * V_{\text{collected}}$$