



**Faculty of Science and Technology**

# **MASTER'S THESIS**

Study program/ Specialization: Petroleum Engineering Drilling technology	Spring semester, 2014  Restricted access
Writer: Martin Spinnangr	..... (Writer's signature)
Faculty supervisor: Helge Hodne  External supervisor: Lasse Haugland	
Thesis title: Downhole mechanical milling operations using low power drive systems (wireline tractor systems powered via an electric wireline).	
Credits (ECTS): 30	
Key words: Wireline tractor Milling Weight on bit DC motor Torque	Pages: 60  + enclosure: 15  Stavanger, 13.06.2014 Date/year



## **ABSTRACT**

Wireline tractor milling is getting more common and it is expected continue to growing in the next decades. The technology will potentially take over more of the downhole milling market, and its full potential will come to show with new technological improvements and better utilization of the technology already in place. For now coiled tubing technology is a preferred intervention method for many milling operations, as it is stronger than tractor milling and has the ability to circulate debris and swarf. The downside with a coiled tubing unit is that it needs longer rig-up time, larger field staff and will have a much greater cost than wireline tractor technology. For these reasons a proven tractor milling technology will most likely be preferred over coiled tubing units in the future.

The goal with this thesis was to utilize the limited power available from the tractor toolstring and verify how to best make a hole of four inches in high alloy steel obstacles. Several tests and theoretical calculations were carried out to verify the best suited bit and to find the best possible operational window, i.e. rotational speed and weight on bit, for these bits.

From the conducted tests it was concluded that the tractor technology is strong enough to mill through high alloy steel obstacles, but that the technology is still not ready to take on the most difficult milling tasks. Surprisingly enough, it was a standard hole saw that had the best test results and was capable of cutting through steel plates of 13Cr, S13Cr and Inconel 718. The diamond grinding bits turned out to work on both 13Cr and S13Cr, but not so well on Inconel 718 obstacles. It was also concluded that for some operations the present toolstring design is insufficient, or at least not optimal. A proper milling toolstring design should include good centralisation close to the bit and a reliable method to control the weight on bit. Therefore, a new weight on bit control concept is presented. The new concept is mainly meant as a quick fix solution, while more comprehensive and advanced weight control units are being developed.



## **ACKNOWLEDGEMENTS**

This thesis is the last task of my master's degree in petroleum technology at the University of Stavanger (UIS). It was written in cooperation of Qinterra Technologies, where I have been working since October 2012.

I want to thank my UIS supervisor Helge Hodne for constructive feedback throughout the process. I also would like to thank my boss Lasse Haugland and my colleagues Gerald McNally, Helge Lien and Leif Arne Sjølyst for valuable discussions, inputs and much needed help during the tests.



## Table of Contents

ABSTRACT .....	III
ACKNOWLEDGEMENTS .....	V
Table of Contents .....	VII
NOMENCLATURE.....	XI
1 Introduction.....	1
1.1 Background.....	1
1.2 Qinterra Technologies .....	3
1.3 Thesis objective .....	3
1.4 Limitations.....	4
1.5 Build-up of thesis.....	4
2 Literature review .....	5
2.1 Isolation valves .....	5
2.1.1 Ball valves .....	6
2.1.2 Flapper valves .....	7
2.2 Material data .....	7
2.3 Present milling toolstring design .....	8
2.3.1 PowerTrack Advance .....	9
2.3.2 Direct Drive Rotation .....	9
2.3.3 Shock Absorber .....	10
2.3.4 Gear box .....	10
2.4 Bit overview .....	11
2.4.1 Full mills .....	11
2.4.2 Hole saws .....	12
2.5 Bit selection criteria.....	13
2.5.1 Amount of steel to be removed .....	14
2.5.2 Bit capability .....	14

2.5.3	Cleaning of bit.....	14
2.5.4	Weight on bit.....	15
2.5.5	Power limitations.....	15
2.5.6	Limitations of the DDR.....	17
2.5.7	Drive parameters .....	19
2.6	Bit selection .....	23
2.6.1	Hardline standard hole saw from Karnarsh.....	24
2.6.2	Diamond impregnated hole saws .....	24
3	Test setup and test outline.....	29
3.1	Test setup.....	30
3.2	Test procedure .....	30
4	Results.....	33
4.1	Preliminary test with standard hole saw .....	33
4.2	SXDS test results .....	34
4.2.1	Target one - 13Cr .....	34
4.2.2	Target two – S13Cr .....	35
4.3	SQDS test results .....	36
4.3.1	Target one – 13Cr.....	36
4.3.2	Target two – S13Cr .....	38
4.3.3	Target three – Inconel 718 .....	40
4.4	Results with standard hole saw.....	41
4.4.1	Target one - 13Cr .....	41
4.4.2	Target two - S13Cr.....	42
4.4.3	Target three – Inconel 718 .....	43
5	Discussion .....	45
5.1	Bit evaluation.....	45
5.1.1	SXDS.....	45



5.1.2	SQDS.....	46
5.1.3	The standard hole saw .....	48
5.2	Power limitation .....	49
5.2.1	Weight on bit.....	49
6	Conclusion .....	51
7	WOB control proposal and future work.....	53
7.1	WOB control proposal.....	53
7.2	Future work.....	57
7.2.1	Motor opportunities.....	58
8	REFERENCES .....	59
	APPENDIX A .....	i
	A.1. Alternative torque derivation.....	i
	APPENDIX B .....	iii
	B.1. WOB plots from SXDS tests .....	iii
	B.2. WOB plots from SQDS tests .....	vi
	B.3. WOB plots from standard hole saw tests.....	xiv



## **NOMENCLATURE**

A	Ampere
ASV	Annular safety valve
BPU	Bit Push Unit
CCL	Casing collar locator
CIV	Chemical injection valve
DC	Direct current
DDR	Direct Drive Rotation
DDV	Downhole Deployment Valve
DHSV	Downhole safety valves
FIV	Formation isolation valve
GLV	Gas lift valve
HPHT	High pressure high temperature
PCP	Power control panel
PSP	Power supply panel
PTA	PowerTrac® Advance
RIH	Run in hole
ROP	Rate of penetration
RPM	Revolutions per minute
V	Volt
WIA	Well Intervention Academy
WOB	Weight on bit
X-over	Cross over



# 1 Introduction

## 1.1 Background

During the lifetime of a well it undergoes several stages before it is permanently plugged and abandoned. After a well has been drilled, completed and set up for production, the well may occasionally need to be re-entered for maintenance and technical purposes, called a well intervention.

In the late 1980s technological improvements in drilling technologies led to an increase of highly deviated and horizontal wells. Exposing more of the reservoirs through deviated wells were and are desirable as this can lead to rising the recovery percentage. Highly deviated and horizontal wells resulted in the necessity for new low-cost intervention technologies capable of handling the deviated well geometries. As a response Qinterra Technologies came up with a wireline tractor in 1996, a conveyance tool capable of pushing logging equipment over an extensive horizontal section. Through constant technological developments a wide range of services from wireline tractors are now available, such as scale milling, brushing, honing etc. In addition, services like replacement of gas-lift valves and shifting of sliding sleeves are possible with use of a stoker (Aker Solutions, 2013).

Historically, milling of downhole obstructions in the wellbore have been performed by traditional rigs or coiled tubing units (Joyce, 2009). This comes with a very high cost, both with regards to equipment needed, personnel and rig up time. Utilizing and development of adequate solutions using wireline tractor milling technology has an enormous potential and could possibly reduce the intervention cost considerably. Potential tractor milling services might consist of removing obstacles, like:

- Stuck flapper valves
- Stuck ball valves
- Scale
- Nipple profiles
- Non-retrievable plugs

The technical solution of milling with coiled tubing has some advantages over wireline tractor milling (Juel et al., 2009). One major advantage with coiled tubing is the ability to circulate.

Circulation is beneficial because it enables removal of cuttings and cools the bit while milling. Since a tractor toolstring is run on an electric wireline, it will never be possible to perform circulation in the same manner as with coiled tubing. In addition, downhole coiled tubing motors are more powerful, can perform tougher milling operations and the effective milling time will be lower. So why should operators want to utilize tractor milling technology? The answer lies mainly in the low cost, see Figure 1.1.

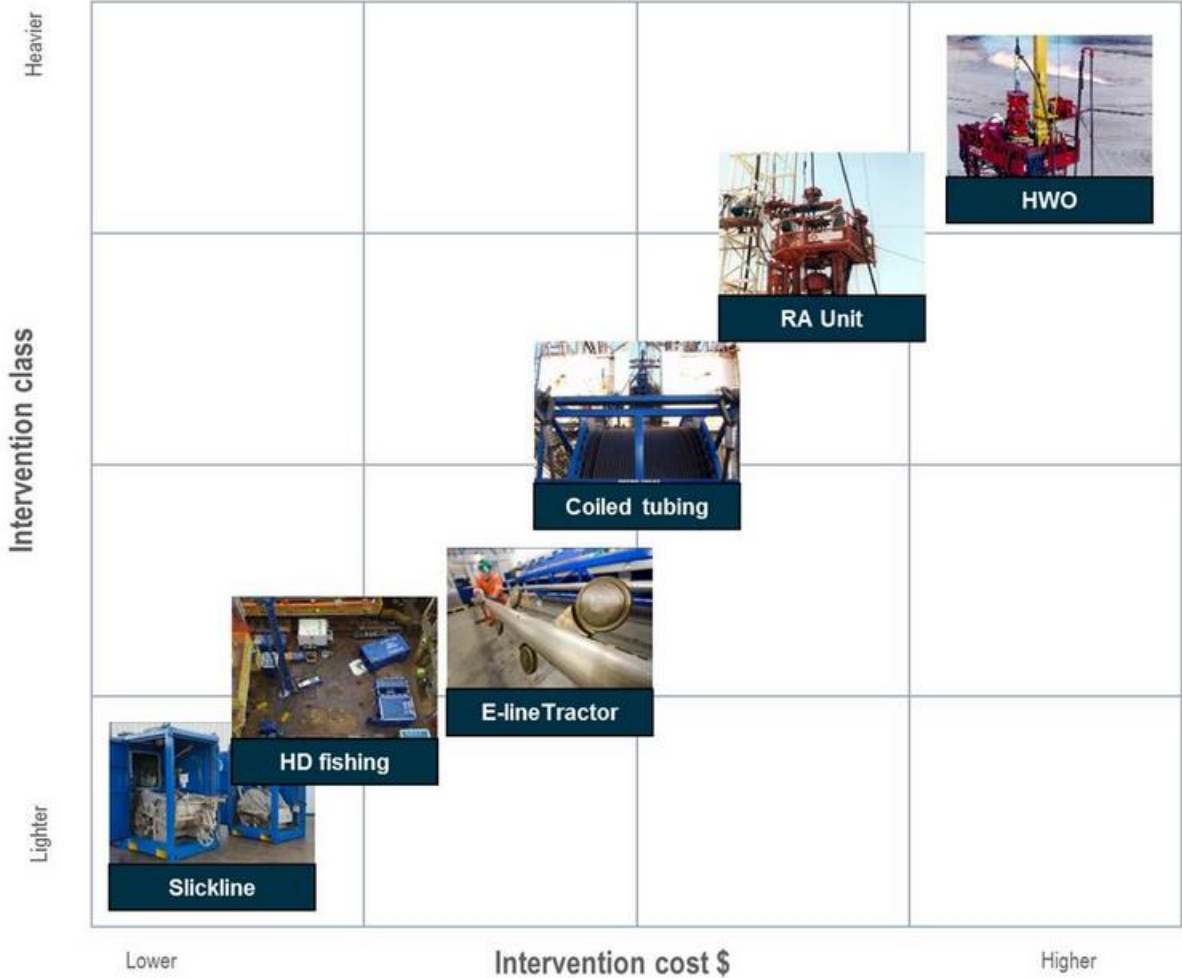

**Figure 1.1 – Cost comparison of different intervention packages. Wireline Tractor (E-line tractor) has a significantly lower cost than Coiled tubing. For now Wireline Tractor is the cheapest intervention method for inclined and horizontal wells**

While operations with conventional coiled tubing units require mobilization heavy equipment, long rig up time, crane lifts, large staffs, an electric wireline solution can be mobilized and deployed quickly and with a small staff involved (Larkins and Mitchell, 2011). Therefore, if it is possible to expand tractor milling capabilities it will hold a huge marked potential and help reduce the intervention costs for the operator companies.

## **1.2 Qinterra Technologies**

Qinterra Technologies offers well intervention services both offshore and onshore all over the world. It was previously named Aker Well Service, and was a part of Aker Solutions. January 2014 it was acquired by EQT, a Swedish private equity fund. Since then a new name and corporate structure have been established. Employees in Scandinavia and UK operate under the Altus Intervention brand. A second brand, a sister company of Altus Intervention Services is called Qinterra Technologies. Qinterra Technologies manages the wireline tractor assets, and drive R&D, for both the wireline tractors and mechanical tools, plugs, packers and other products. This thesis is written in cooperation with Qinterra Technologies.

## **1.3 Thesis objective**

*Downhole mechanical milling operations using low power drive systems (wireline tractor systems powered via an electric wireline).*

The sub objectives:

1. Establish an overview of potential milling bits
2. Find best suited bit
3. Establish limitations of the rotational motor
4. Find operational window for best suited bit, i.e. optimal weight on bit and rotational speed
5. Develop a weight on bit control concept

As mentioned in the introduction there is a wide range of possible milling opportunities for wireline tractor technology. In this thesis the focus was to find solutions for milling through stuck flapper valves and ball valves. Further, the objective of the tests was to find a suited bit to make 4in (101.6mm) holes through the valves. The reason for this limitation was that a standard tractor from Qinterra Technologies has an outer diameter (OD) of 3.125in (79.375mm), and with a 4in hole the tractor toolstring would be able to pass through with sufficient clearance. Based upon previous tests and knowledge within Qinterra Technologies it was thought that the toughest material in any steel-milling operation was Inconel 718. For that reason the main objective was to find suitable solutions for making a 4in hole in an obstacle, inoperable flapper or ball valve, made of alloy grades up to Inconel 718.

## **1.4 Limitations**

The tests covered in this thesis only revolved in utilizing existing downhole equipment already within the Quinterra Technologies portfolio.

Due to long lead time on the bits and on the test bench (see Figure 3.1 in Chapter 3), a comprehensive test-program was not possible to carry out within the timeline. The tests carried out were mainly conducted to verify whether or not the bits worked with the limited power available and to document which of the three bits gave the most promising results with which of the two gearbox options available (see Chapter 2.3.4). Because of lead time and cost of valves, the milling tests were carried out on flat metal plates, made of the actual steel grades.

As is explained in Chapter 2.5.5, there are different settings on the rotational motor. To change the setting from one to another would have required a full workday for a trained mechanic. Because of already limited resources in the workshop this was not possible, and the tests had to be carried out with the available equipment whatever the setting was. For these reasons the thesis had to be more theoretical and less experimental than first anticipated, and some of the theories presented need to be tested further for final verification.

## **1.5 Build-up of thesis**

The thesis is divided into seven main sections. In the first section a short introduction and background is given about the use of wireline tractor technology, including thesis objective and limitations. In the second section a literature review is presented, with basic information about valves, material data, toolstring components, important factors with regards to bit selection and limitations on the rotational motor. The third part covers a description of how the testing was carried out, test setup, test procedure, and how the actual data was contained. The fourth section presents findings and results from the tests. In the fifth section a discussion regarding the conducted tests is presented. The sixth section covers conclusions that could be made from the test results. In the final section a WOB control proposal is presented, in addition future work is discussed.



## **2 Literature review**

Milling of valves are only applicable for valves becoming obstacles inside the completion, and it will always just be a contingency plan when valves have become inoperable and other measures to operate the valves have failed. A well may contain a wide range of downhole valves, e.g. downhole safety valves (DHSV), annular safety valves (ASV), gas lift valves (GLV), chemical injection valves (CIV), isolation valves, etc. The ASV is located in the A-annulus, between completion and casing, and both the GLV and the CIV are located in side pocket mandrels, they will therefore never become obstacles inside the tubing. The DHSV is often designed as a flapper or ball valve. However, it is a primary well barrier, and if it becomes inoperable it will have to be replaced immediately. Depending on the design it can either be retrieved by wireline, or by retrieving the tubing. This in turn means that it will never become an obstacle needed to be milled away. For this reason only downhole isolation valves will be described further. Figure 2.1 shows an example of Schlumberger's formation isolation valve (FIV) and where it is typically placed in the completion.

In a milling prospective, one of the key parameters to establish is the materials of the valves, and what mechanical properties these steel alloys hold. As discussed in Chapter 2.5 this could be of interest when it comes to bit selection and operational concerns like weight on bit (WOB) and rotational speed. The tests carried out in Chapter 4 are based on theory and information stated in this chapter.

### **2.1 Isolation valves**

Isolation valves have a broad range of applications, but their main purpose is to isolate the reservoir from the wellbore. Other applications for the isolation valves may be to enable:

- Fluid loss control
- Underbalanced perforation
- Well control barrier operations
- Deep-set lubrication
- Multizone isolation



Figure 2.1 - Completion example (Schlumberger, 2009). Typically the FIV is located just above the kickoff point. Schlumberger's FIV is designed as a ball valve

There are essentially three designs for isolation valves; ball valve, flapper valve and sleeve valve (Schlumberger, 2009). The sleeve valves will not become a mill-able obstacle and is therefore not described further.

### 2.1.1 Ball valves

Design variations do exist, but the basic principle of all ball valve designs are the same. It is based on a rotating ball and a floating seal design. This facilitates the possibility to seal of the well and contain pressure above or below the ball. Depending on the completion concept the

ball valves can either be operated mechanically, meaning that a shifting tool is needed to open or close the valve, or controlled from surface with control lines (Schlumberger, 2009).

**2.1.2 Flapper valves**

The flapper valve design differs from the ball valve designs as it uses a flapper as the sealing barrier. An example of a flapper valve is Weatherford’s Downhole Deployment Valve (DDV) (see Figure 2.2), which is an integrated part of the completion and allows for full bore passage when in open position (Timms et al., 2005). Design differences exist, but generally all flapper valves are designed with a curve that enables less restriction in the wellbore.



Figure 2.2 – Weatherford’s flapper valve in closed, partially open and open position (Weatherford, 2012)

**2.2 Material data**

According to Norsok M-001 Material Selection section 5.3 typical materials for downhole valves are 13Cr, S13Cr, duplex stainless steels and nickel alloys. Common for all of these alloys is that they are some sort of stainless steel, meaning that they hold resistance to corrosion. Comparing stainless steels to mild steels, stainless steels are usually stronger and harder, have higher ductility and better heat strength (Belayneh, 2013). Further the material selection is depending on type of well, e.g. oil producer, gas producer, water injector, gas injector, and well parameters like pressure and temperature. Table 2.1 presents the mechanical properties for steel grades used during the tests. It is important to know that there are a wide variety of grades for each of these steels groups.

**Table 2.1 - Mechanical properties of steel grades used during tests**

Property	13Cr*	S13CR**	Inconel 718***
Tensile strength, ksi	123	120	180
Yield strength (0.2% offset), ksi	87	110	150
Hardness (HRC)	23	32	36

\* Aisi 420M-13Cr (Sverdrup Steel, 2012a)

\*\* P110 (Sverdrup Steel, 2012b)

\*\*\*Mechanical properties of bars in Inconel 718 (Special Metals Corporation, 2007)

13Cr is a martensitic stainless steel, which is given its name because of the 13% Chromium content. It is not as corrosion resistant as other stainless steel groups, but is known for its high mechanical strength and toughness. Super 13Cr (S13Cr) is still martensitic, but to increase the corrosion resistance and improve the yield strength the alloy contains a higher molybdenum and nickel content (Belayneh, 2013). Duplex and super Duplex stainless steels are typically used in high pressure high temperature (HPHT) wells, and are recognized to combine high pitting resistance, high strength and heat resistance. Inconel is a family of superalloys based on an austenitic nickel and chromium structure. Inconel 718 or alloy 718 as it often is called, is specified as a precipitation-hardened stainless steel with high yield and tensile strength, and is typically used for high temperature applications and in wells where there is a high acid content. When machining Inconel 718, because of its high strength and work-hardening characteristics, it is very important with the correct tool materials and design, operating speeds and coolants (Special Metals Corporation, 2007). For the same reasons Inconel 718 is thought of as being very difficult to remove with tractor milling equipment.

**2.3 Present milling toolstring design**

The next part will provide a quick review of the basic toolstring components and their function with regards to milling operations, with bases in Qinterra Technologies portfolio. In Figure 2.3 an example of a common toolstring design used for milling is shown. The bit selection, which is of utmost importance, will be covered in Chapter 2.6.

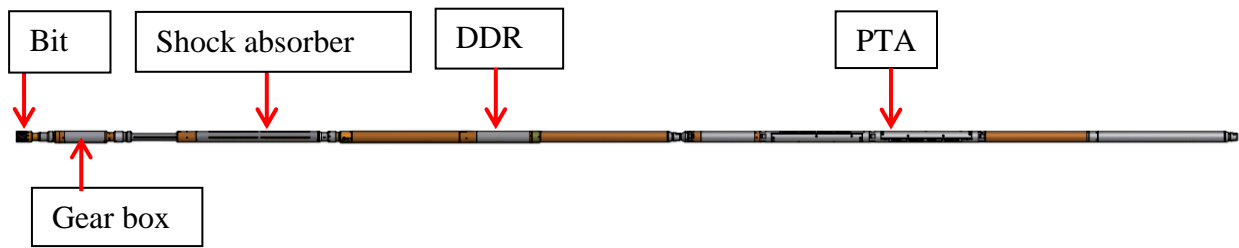

**Figure 2.3 - Toolstring example.** When no debris collecting is required (scale milling often requires debris collecting), this is a common toolstring design. Additional components like cable head and casing collar locator (CCL) will also be included in the toolstring

### 2.3.1 PowerTrack Advance

Qinterra Technologies' wireline tractor is called PowerTrac® Advance (PTA). This is the foundation of any inclined or horizontal wireline intervention service. It was developed as a mean off conveyance, but has since its introduction expended its usage areas. During a milling operation it provides transportation, stability, centralization, weight on bit (WOB), and keeps the toolstring anchored to the tubing wall while milling. It is powered by electrical power transmitted on the wireline to the tractor's electrical motor, which drives a hydraulic pump that activates the wheel section (see Figure 2.4) and moves the toolstring forward.



**Figure 2.4 - PTA 318 (Aker Well Service, 2012a).** The PTA consists of four main sections; electric section, motor/pump section, wheel section and compensator section

### 2.3.2 Direct Drive Rotation

The PowerTrac® Direct Drive Rotation (DDR) is a DC-powered downhole rotational system based on the PTA motor technology. While the PTA provides anchoring and WOB the DDR system provides torque. Figure 2.5 shows a picture of the DDR 318. There also exists a 212

version with a smaller outer diameter (OD), possessing a motor just as strong. In Chapter 2.5.5 more information regarding the DDR will be given.



**Figure 2.5 - DDR 318 (Aker Well Service, 2012b)**

### **2.3.3 Shock Absorber**

As the name implies the Shock Absorber, absorbs impacts/shocks which the toolstring may encounter. It is a spring loaded damper with a rotational shaft, placed underneath the DDR. For a typical milling operation it has one more key feature, when the PTA is in a locked position, the Shock Absorber acts as a feeding mechanism for the bit. With this setup the spring force determines the WOB.

### **2.3.4 Gear box**

When the DDR is run on full capacity it can provide a total of 180RPM and 110Nm (81.13lb<sub>f</sub>-ft). Subject to the obstacle in question, it may be required with more force and less RPM. This can be setup with the proper gearing in the gearbox. However, when this thesis was written there were only two gearing options available, 1:1 and 3:1. More about this is covered in Chapter 2.5.6. When the 1:1 gearbox is used it only works as a cross over (x-over) between the Shock Absorber and the bit.

## 2.4 Bit overview

Essentially there are two main groups of bits. The first one is the full contact bits, the full mills, meaning that the entire OD of the bit is in contact with the target material. Normally, roller cone bits and PDC bits will fall into this category, but these are drilling bits, best suited for formations and in softer materials and will therefore not be covered here. The second group is the hole saw option, where a hole is created without having to cut the core material.

### 2.4.1 Full mills

#### 2.4.1.1 Carbide cutters

There is a wide variety of design solutions for tungsten fixed cutters. It can be everything from a simple steel rod with broken carbide pieces, too a costly full precision bit as shown in Figure 2.6.

As a contrast to precision mills are the crushed carbide mills, as shown in Figure 2.7. On these bits the cutter points will be more random, and as a result there will usually be unpredictable torque in the beginning, followed by slow rate of penetration (ROP) as the cutter points are weighted down and rounded (Portman and Short, 2000).



Figure 2.6 - Fixed carbide bit (Portman and Short, 2000)



Figure 2.7 - Five bladed crushed carbide junk mill (Famco, 2013)

### 2.4.1.2 *Natural diamond cutters*

Tests have shown (Portman and Short, 2000) that natural diamond cutter can be used in some hard grades of steel, but they were originally designed to be used for openhole drilling. The advantages of using these bits are that they require low torque and leave a very smooth cut. The main disadvantage is that natural diamond bits typically experience low ROP. An example of a natural diamond cutter is shown in Figure 2.8.



**Figure 2.8 - MDXT natural diamond cutter (Short Bits & Tool Co., 2014)**

### 2.4.1.3 *Diamond impregnated cutters*

If the target is uneven and strong a diamond impregnated bit, example shown in Figure 2.9, can be a good solution. These bits will act in a similar fashion as the broken carbide chip bits, and grind its way through the target, but will leave a smoother cut and will most likely have a longer life. In a drilling prospective they are mainly used in abrasive sand or unconsolidated formations, but they have been proven to work well for milling through high alloy steels on coiled tubing operations.



**Figure 2.9 - MXT diamond impregnated bit (Short Bits & Tool Co., 2014b)**

## 2.4.2 **Hole saws**

A hole saw, or a burning shoe as it is frequently is called, is cylinder formed with cutting or grinding blades, which creates a circular hole in the target without having to cut the core.

### 2.4.2.1 *Standard hole saw*

The standard steel cutting hole saws are made for use in stable drill press machines, with full feed control. The leading suppliers claim that their best hole saws are capable of cutting steel grades up to 40 Rockwell (HRC) (Karnasch, 2012), which is harder than both Inconel and



Super Duplex. The strongest hole saws are commonly carbide tipped core drills equipped with Sandvik carbide teeth.

#### **2.4.2.2 Crushed carbide hole saw**

The crushed carbide hole saw works in a similar matter as the crushed carbide full mill. The hole saw will grind away steel, without grinding in the core. The cutter points will usually be random and with uneven height as shown in Figure 2.10.



**Figure 2.10 - Crushed carbide hole saw (Diaset, 2013)**

#### **2.4.2.3 Diamond impregnated hole saw**

The diamond impregnated burning shoes are built by the same principle as the diamond impregnated full contact bits. The cutting surface sustains typically 15-20% diamond grit and the rest is a mixture of tungsten, tungsten carbide, and a nickel alloy. The cutting action is similar to diamond impregnated full mills, where each diamond particle will work against the target until it is either consumed by frictional heat or fractured from impact loading, at which time it will be sloughed out, the target will wear the matrix down and expose new diamond grits.

### **2.5 Bit selection criteria**

There is a broad expertise within the industry when it comes to drill bits and mill designs. This is however mainly for the use of a conventional drilling rig or a coiled tubing unit. Rather than going into established theories only related to more heavy duty milling machinery, the next part will evaluate bit requirements that are unique to wireline tractor milling. Milling operations experience low performances for a number of reasons, some of these are:

1. The bit is not suited for the operation
2. Insufficient cleaning of bit
3. Insufficient weight on bit
4. Downhole motor not strong enough to turn bit
5. Inadequate centralisation of the bit

There are some additional parameters to consider regarding bit selection:

- Amount of steel needed to be removed
- Size of swarf
- Reliability
- Time needed

### **2.5.1 Amount of steel to be removed**

A hole saw will almost always be quicker than a full mill, simply because of the amount of work done. Cutting through an obstacle with any full mill will create a large amount of cuttings, and with no fluid circulation that could cause a problem (Short, 2014a). As stated in Chapters 2.5.7.2 and 2.6.2 there are some additional benefits of choosing a hole saw bit, like less required WOB and torque. For these reasons, only hole saws were used during the testing and therefore only hole saws will be discussed further.

### **2.5.2 Bit capability**

Finding a bit capable of handling the given target should be fairly easy, as all bit suppliers supply information covering which material the actual bit can handle. How reliable and lifetime expectancy is very depended on the operator, and the machinery used to make the hole. As these bits shall be used for a downhole milling operations limited to wireline tractor technology, they are not thought of as off the shelf. There are many operational concerns to be considered.

### **2.5.3 Cleaning of bit**

Since there are no circulation possibilities for a tractor toolstring, cleaning of the bit may become a larger issue than for coiled tubing milling. Most of these concerns can be mitigated by a good bit design. By use of either crushed carbide or diamond impregnated bits there will be no considerable swarf created, and the size will be much less than from a standard hole saw.

#### **2.5.4 Weight on bit**

When a capable bit is found for a given material, the next step will be to figure whether or not this bit will work properly given the limitations on the toolstring. E.g. selecting a bit needing 1000s of kilograms WOB to work well will not be optimal for a tractor milling string.

With the present milling toolstring design (see Chapter 2.3) there are two ways of applying WOB:

1. Weight of toolstring
2. Traction on PTA combined with Shock Absorber

When number one is used the PTA is set up with rolling anchors, or freewheeling as it often is called. This means that there is no drive force applied to the tractor wheels, but that they are still pushed towards the tubing wall to provide centralization to the bit and to prevent the toolstring from spinning while milling. If obstacles are located in vertical or low inclination sections of the well, only a freewheeling setup would be required. It may however be necessary to add additional weights to be able of applying sufficient weight.

If obstacles are located in horizontal or highly inclined sections of a well it would be impossible to reach the intended depth without traction on the wheels. Nonetheless, have any opportunity of applying sufficient WOB. The most common procedure when dealing with an obstacle located in a horizontal section is that the tractor drives the toolstring to and compresses the Shock Absorber's spring against target, and then the spring applies WOB.

#### **2.5.5 Power limitations**

The next section is important because it sets up some of the limitations for the tractor applications used today. The downhole tools are run on an electrical cable, called wireline. Electric power is transmitted from a surface power supply panel (PSP), and the output power is controlled from a power control panel (PCP). From the PCP, the operator can adjust the bottomhole voltage level, i.e. level at the downhole tools. For this to be possible the PCP automatically adjust the output voltage from the PSP, so that it is sufficient to overcome the voltage drop that occurs over the cable length. The resistance of the entire cable is always measured before an operation; this is then plotted on the PCP, and by use of Ohms law (see Eq. (2.1)) the PCP calculates the voltage drop and adjusts the output voltage accordingly to supply the downhole tools with the intended voltage level.

$$U_{drop} = RI \quad (2.1)$$

Where:

- $U_{drop}$  = Voltage drop (voltage, V)  
 $R$  = Resistance of entire cable (ohms,  $\Omega$ )  
 $I$  = Current (ampere, A)

The bottomhole voltage level is then:

$$U_{bottomhole} = U_{output} - U_{drop} \quad (2.2)$$

Electrical power ( $PWR_{el}$ ) can be defined as:

$$PWR_{el} = UI \quad (2.3)$$

Given the limitations of the electrical cable, the PSP and the PCP the maximum possible bottomhole power, with solutions used today, is set to 450 volts (V) and 8.3 amperes (A). Inserting this into Eq. (2.4) the maximum available electrical power to downhole tools is set to:

$$PWR_{el} = 450V \cdot 8.3A = 3735watts = 3.735kW$$

The DDR is only a rotational tool and is therefore in the need of additional anchoring to provide torque. For the present toolstring (see Figure 2.3) this means it must run together with a PTA. The DDR and the PTA have the same type of motors, where each motor can operate with voltages up to 450V and current draws up to 6.6A. This means that each motor is capable of providing:

$$PWR_{el} = 450V \cdot 6.6A = 2970watts = 2.97kW$$

This further means that there is not enough electrical power for both engines to run on full capacity. For that reason, either the PTA or the DDR, or both, will be adjusted to not run on full power. To choose one option over the other means either compromising the traction capability, or compromising the power available for the DDR. E.g. a standard PTA 318 will with maximum wheel load use up to approximately 6A (McInally, 2010). With an 8.3A PSP this gives only 2.3A available for the DDR motor. In principle, there is a range of setups to divide the electrical power between the DDR and the PTA. Table 2.2 shows three different setups for the DDR with the potential current draw for each setting.

**Table 2.2 – Available current draw for the DDR from three different settings**

Setting	Setting 1	Setting 2	Setting 3
	Horizontal milling	Horizontal/inclined milling	Vertical milling
Current draw on the DDR	2.3A	4A	6.6A

In vertical applications where no wheel traction is required, the PTA can be set up as freewheeling (see Chapter 2.5.4), which will only require approximately 2.3A. With this setup the DDR can be run on full capacity.

The most common setup for the DDR is that it can use up to about 4A (Rege, 2014). This means that it is not running at full capacity, but that the tractor can be set up with some traction on the wheels.

### **2.5.6 Limitations of the DDR**

When the bit is not turning, caused by motor stalling, it means that the motor is not capable of providing sufficient torque to turn the bit. As Qinterra Technologies do not have other rotational motors than the DDR it becomes of utmost importance to utilize the potential energy transfer to the maximum. The DDR is driven by a 2.97kW electrical direct current (DC) motor. For DC motors the stall torque, i.e. the maximum torque the motor can provide before stalling, is proportional to the maximum current consumption no matter what the speed is, while the rotational speed is proportional to the applied voltage (Center for Innovation in Product Development - MIT class notes, 2009).

In DC motors, electrical power ( $PWR_{el}$ ) is converted to rotational mechanical power ( $PWR_{rot}$ ) and power loss ( $PWR_{loss}$ ):

$$PWR_{el} = PWR_{rot} + PWR_{loss} \quad (2.4)$$

And rotational mechanical power can be defined as:

$$PWR_{rot} = T\omega_{rad} \quad (2.5)$$

Where:

U = voltage [V]

I = current [A]

T = torque [Nm]  
 $\omega_{rad}$  = angular velocity [rad/sec]

The rotational motor then has a theoretical efficiency (n) of:

$$n = \frac{PWR_{rot}}{PWR_{el}} = \frac{PWR_{el} - PWR_{loss}}{PWR_{el}} \quad (2.6)$$

Rearranging Eq. (2.6):

$$PWR_{loss} = PWR_{el} - nPWR_{el} \quad (2.7)$$

Inserting Eq. (2.7) into Eq. (2.4), substituting  $PWR_{el}$  and  $PWR_{rot}$  with Eq. (2.3) and Eq. (2.5) respectively:

$$UI = T\omega_{rad} + UI - nUI \quad (2.8)$$

The stall torque ( $T_{stall}$ ) can then be defined by:

$$T_{stall} = \frac{nUI}{\omega_{rad}} \quad (2.9)$$

According to Qinterra Technologies' own presentations (Aker Solutions, 2013) the DDR is capable of providing 180RPM and 110Nm when run on full capacity. Converting RPM to rad/sec:

$$\omega_{rad} = \omega_{RPM} * \frac{2\pi}{60} = 180 * 0.10472 = 18.85 \text{ rad/sec}$$

Inserting this into Eq. (2.5):

$$PWR_{rot} = 110Nm * 18.85rad/sec = 2073.46watts \approx 2.07kW$$

This means that the DDR have 2.07kW available for the milling operation. This also means that energy lost ( $PWR_{loss}$ ), to heat, friction etc., is estimated to 0.897kW, which according to Eq. (2.6) means the rotational motor has a theoretical efficiency (n) of:

$$n = \frac{2073.46W}{2970W} = 0.698 \approx 0.7$$

Figure 2.11 shows Eq. (2.9), i.e. the theoretical stall torque, provided from the DDR when on 450V, with a motor efficiency of 0.7 and with current data provided in Table 2.2.

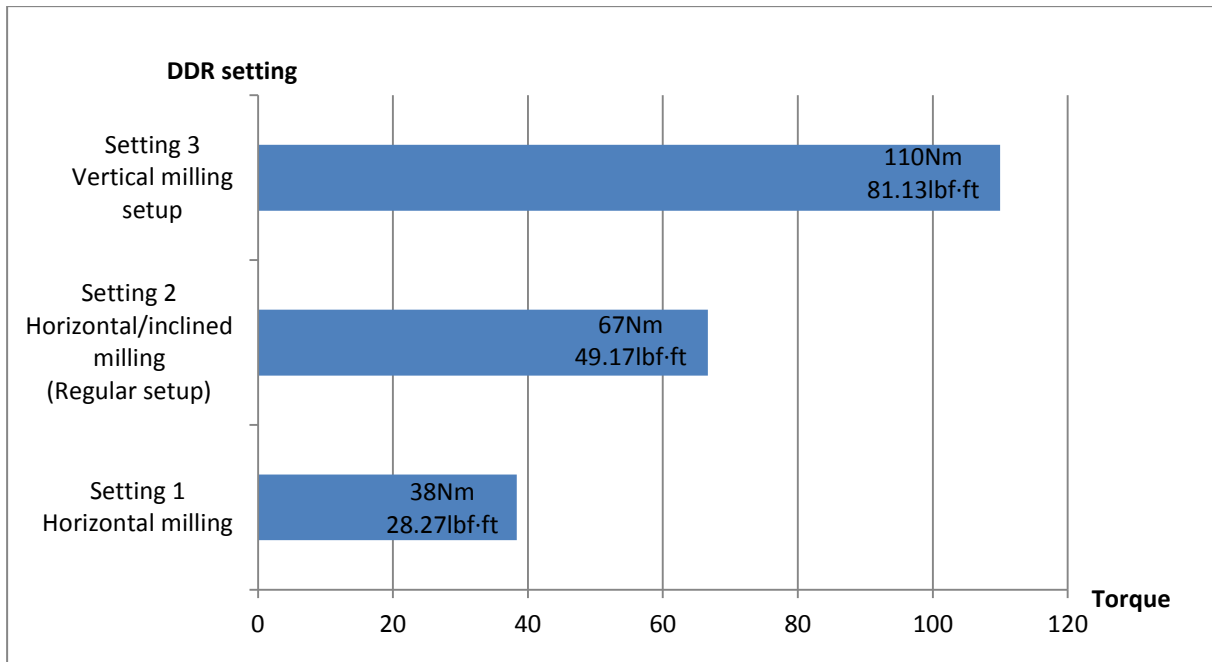

**Figure 2.11 - Theoretical stall torque on DDR based on settings from Table 2.2. In other words the PTA setup determines the DDR setup, i.e. how much power the DDR is capable of providing. Note that the setting does not affect the RPM, only how much the maximum torque the DDR can provide**

Ratio between torque and rotational speed can be changed by use of a gearbox. E.g. with a 3:1 gearbox and with the DDR run on full capacity, the rotational speed would be divided by three, resulting in rotational speed of 60RPM, while the available torque would be three times as high, resulting in 330Nm. This example is under the assumption that no further energy loss will be caused as a result of the gearbox.

### 2.5.7 Drive parameters

The next part will look in to two different scenarios; the standard hole saw solution which cuts steel, and the grinding solutions, i.e. the crushed carbide and the impregnated diamond shoes.

#### 2.5.7.1 Standard hole saw

Suppliers of standard hole saws (shown in Figure 2.12) provide a recommended RPM and feed depending on hole size and material of target. For this setup there is no



**Figure 2.12 - Standard hole saw from Karnash. This hole saw was used during some of the tests. It is equipped with Sandvik tungsten carbide teeth**

feed control, only weight and rotational speed. For that reason, the main concerns when using these bits were to gear the DDR correctly according to recommended rotational speed, to see how the bit coped with the target materials and how it performed with a range of different WOB.

**2.5.7.2 The grinding solutions**

For grinding solutions there will always be better progress with high rotational speed compared to low rotational speed. The diamond or carbide particles will grind away small pieces of the target for every turn. Therefore, it is of high interest to run the DDR at maximum speed while still having enough force available to turn the bit.

R. C. Pessier and Fear (1992) published in a SPE article regarding common drilling problems with mechanical specific energy and a bit-specific coefficient of sliding friction the following approximation for drag bits:

$$T = \frac{\mu WOBd}{36} \tag{2.10}$$

Where:

- T = torque [lb<sub>f</sub>·ft]
- μ = friction coefficient
- WOB = weight on bit [lb<sub>f</sub>]
- d = bit diameter [in]

The same relationship has been published by several other authors, and it has shown to be a good approximation (Portman and Short, 2000). Note that the unit for torque from this equation is foot-pound, while the bit diameter is given in inches. To use this equation in metric units the approximation reads:

$$T = \frac{\mu WOBd}{3} \tag{2.11}$$

Eq. (2.10) and (2.11) indicate that torque is approximated to be linear with WOB. This approximation is for a full mill in formation drilling. However, by following the same assumptions and simplifications as Pressier and Fear, and by the use of uniform pressure theory a similar relationship can be derived for a hole saw bit.



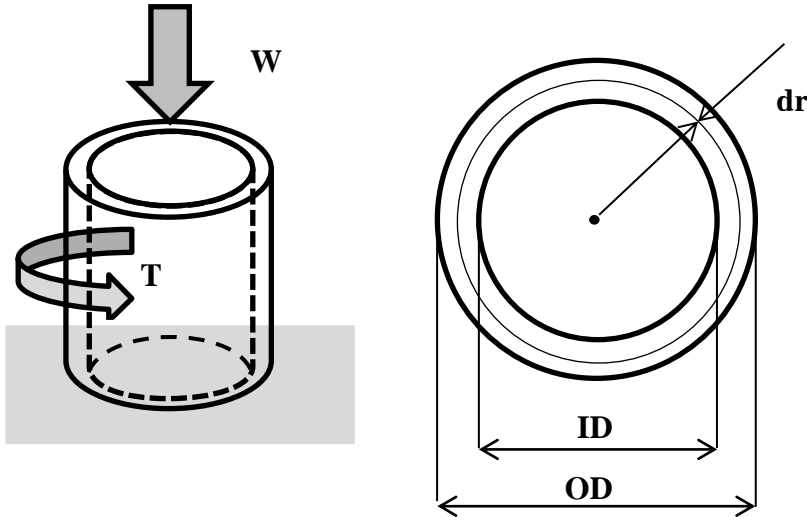

Figure 2.13 – Model used to derive a force approximation for grinding hole saw bits

Assumption for the following derivation is that the grinding bit is uniform; meaning that the entire grinding surface is in contact with the target. The bit is pushed against the target with a force  $W$ .

Consider a fundamental ring on the contact surface of the bit at radius  $r$  and with radial width  $dr$ , see Figure 2.13. The area of the ring ( $dA$ ) is approximately the circumference times the width  $dr$ .

$$dA = 2\pi r dr \quad (2.12)$$

In the contact area between the bit and the surface a uniform pressure ( $p$ ) is produced. The normal force acting on the surface is  $N$  and the force acting on the fundamental ring is then:

$$dN = p dA \quad (2.13)$$

Substituting  $dA$  with Eq. (2.12):

$$dN = p 2\pi r dr \quad (2.14)$$

The total force  $N$  acting on the grinding area is then given by integration:

$$N = \int_{\frac{ID}{2}}^{\frac{OD}{2}} p 2\pi r dr = p 2\pi \int_{\frac{ID}{2}}^{\frac{OD}{2}} r dr = p 2\pi \left[ \frac{r^2}{2} \right]_{\frac{ID}{2}}^{\frac{OD}{2}} = \frac{p\pi}{4} [OD^2 - ID^2]$$

$$p = \frac{4N}{\pi [OD^2 - ID^2]} \quad (2.15)$$

When the bit rotates, the friction force acting on the fundamental ring is  $\mu dN$ . This force produces a small torque:

$$dT = \mu r dN = \mu p 2\pi r^2 dr \quad (2.16)$$

The total torque is obtained by integration between inner radius and outer radius:

$$T = \mu p 2\pi \int_{\frac{ID}{2}}^{\frac{OD}{2}} r^2 dr = \mu p 2\pi \left[ \frac{r^3}{3} \right]_{\frac{ID}{2}}^{\frac{OD}{2}} = \frac{\mu p \pi}{12} [OD^3 - ID^3] \quad (2.17)$$

Substituting Eq. (2.15) for  $p$ , and since  $N$  is equal to  $WOB$  we get:

$$T = \frac{\mu WOB}{3} \left[ \frac{OD^3 - ID^3}{OD^2 - ID^2} \right] \quad (2.18)$$

Eq. (2.18) indicates that also for grinding hole saws the torque is approximated to be linear with  $WOB$ . One more important note from Eq. (2.18) is that with an increase of the  $ID$ , meaning decreasing the thickness of the bit, the term  $\left[ \frac{OD^3 - ID^3}{OD^2 - ID^2} \right]$  will increase and result in a higher required torque. This may seem strange. The explanation is that when the same weight is applied to a smaller area, it will produce a higher pressure against the target and thereby a higher torque is required. However, as discussed in Chapter 2.6.2 the necessary torque will still decrease with a thinner hole saw since the optimal  $WOB$  will decrease.

By attacking the problem from another angle and assuming uniform wear the torque approximation reads:

$$T = \frac{\mu WOB (OD + ID)}{4} \quad (2.19)$$

Derivation of Eq. (2.19) is found in A.1 (see APPENDIX A). Eq. (2.19) also indicates that with a larger  $ID$  the required torque will increase for a given  $WOB$ . Note that there is no significant difference to the results of using Eq. (2.18) instead of (2.19), and that the value of using one instead of the other is in this scale negligible. Only Eq. (2.18) will be discussed further in this thesis.

Eq. (2.9) defined the stall torque as:

$$T_{stall} = \frac{nUI}{\omega_{rad}}$$

While Eq. (2.18) defined the required torque to turn a grinding bit as:

$$T = \frac{\mu WOB}{3} \left[ \frac{OD^3 - ID^3}{OD^2 - ID^2} \right]$$

This means that as long as  $T_{stall} > T$ , the DDR will be capable of turning the bit.

Illustrated another way:

$$\left| \begin{array}{l} \frac{nUI}{\omega_{rad}} > \frac{\mu WOB}{3} \left[ \frac{OD^3 - ID^3}{OD^2 - ID^2} \right] \\ \frac{nUI}{\omega_{rad}} < \frac{\mu WOB}{3} \left[ \frac{OD^3 - ID^3}{OD^2 - ID^2} \right] \end{array} \right| \begin{array}{l} \text{Bit keeps rotating} \\ \text{Motor stalls} \end{array} \quad (2.20)$$

## 2.6 Bit selection

The tests were carried out with three different hole saws:

1. Hardline standard hole saw from Karnarsh with an OD of 100mm ( $\approx 4$ in)
2. SXDS from Short bits & Tool Co with an OD of 4in and an ID of 3.5in
3. SQDS a modified construction bit from Short bits & Tool Co with an OD of 4in and an ID of 3.65in

The most important criterion for choosing the bits was reliability. It does not really matter how much time the cutting or grinding action needs as long as the bit gets the job done. Before the tests started, the standard hole saw from Karnarsh was considered as the least reliable option. Because the standard hole saw design was regarded as very vulnerable for impacts and because the design was based for use in stable drill push machines. There were also some uncertainties as to how these bits would act when not 100% centralized and without feed control. However, the costs of these bits were next to nothing compared to the other options. Also, even if it was not as important, if the hole saw worked it was assumed that it would complete the job much faster.

The grinding solutions were considered as more reliable. Because they were deemed not as dependant on centralization and on feed control. In addition, no teeth could break off and prevent further progress. The required cutting time was on the other hand expected to be substantial. Another concern was whether or not it would be possible to stay within the optimal WOB window (see Figure 2.15).

The reason for not including a crushed carbide solution was that the grinding action was considered very similar to that of diamond bits, just in a poorer edition. As discussed in Chapters 2.4.1.1 and 2.4.2.2, crushed carbide bits will have some random high cutting points, these may be exposed to high pressure that can cause the cutting points to be overloaded and dulled. There are also case histories where crushed carbide hole saws have been proven inadequate for high alloy steels, where it became necessary to replace the bit with a diamond impregnated hole saw (Farquhar et al., 2007). For these reasons the hypothesis was that the diamond impregnated bits would be more reliable for steel milling.

### 2.6.1 Hardline standard hole saw from Karnarsh

The main reason for including this bit was that it was very cheap compared to the other solutions. Also, if the tests showed that the hardline saw worked in the test bench it could potentially work with future toolstring solutions, with feed control and good centralization. Karnash claim that their Hard-Line series of hole saws is well suited for cutting Inconel, and even stronger materials (Karnasch, 2012). Figure 2.14 shows RPM recommendations, based on the target's mechanical properties and the size of the hole to be made.





Ø	mm	12-18	19-25	26-32	33-39	40-46	47-53	54-60	61-70	71-80	81-90	91-100	101-112
	Zoll / Inch	7/16" - 1. 1/16"	3/4" - 1"	1. 1/16" - 1. 1/4"	1. 5/16" - 1. 9/16"	1. 5/8" - 1. 13/16"	1. 7/8" - 2. 1/16"	2. 1/8" - 2. 3/8"	2. 13/32" - 2. 3/4"	2. 51/64" - 3. 5/32"	3. 3/16" - 3. 9/16"	3. 19/32" - 3. 15/16"	3. 31/32" - 4. 13/32"
	Stahl · Steel · Acier Accero · Acciaio · Сталь < 500 N	1475 885	838 637	612 498	483 408	398 346	338 300	295 265	261 227	224 199	197 177	175 159	158 142
	Stahl · Steel · Acier Accero · Acciaio · Сталь < 750 N	1327 796	754 537	550 448	434 367	358 311	304 270	265 230	234 204	201 179	177 159	157 143	142 128
	Stahl · Steel · Acier Accero · Acciaio · Сталь < 900 N	930 620	590 450	430 340	335 285	280 240	239 210	205 185	182 160	155 140	137 125	122 110	108 100
	Stahl · Steel · Acier Accero · Acciaio · Сталь < 1200 N	795 530	500 380	370 300	290 245	240 265	200 180	175 160	155 135	135 120	117 105	104 95	94 85
	Stahl · Steel · Acier Accero · Acciaio · Сталь < 1400 N	660 440	420 320	305 250	240 200	195 170	165 150	145 130	125 115	110 100	95 90	85 80	75 70

Figure 2.14 - Recommended RPM for Karnash Hard-Line hole saw (Karnasch, 2012). For a 4in hole the recommended RPM for the target materials (<1400 N) is between 70 and 75

### 2.6.2 Diamond impregnated hole saws

For diamond impregnated hole saws it generally takes 200psi ( $1.38 \cdot 10^6$  Pa) to 600psi ( $4.14 \cdot 10^6$ Pa) to cut hard steel, including Inconel 718 (Short, 2014a). Any less than that can result in the grinding matrix "glazing over". Any more than that can "mash" the matrix so that

it will lose diamond particles, resulting in bad progress and shorter life of bit. The WOB for a uniform hole saw can therefore be defined as:

$$WOB = pA = p \frac{\pi}{4} (OD^2 - ID^2) = p\pi(ODt - t^2) \tag{2.21}$$

Where:

- p = pressure acting between grinding matrix and target
- A = area of grinding matrix
- OD = outer diameter of the bit
- ID = inner diameter of the bit
- t = thickness of bit wall

Inserting 200psi (1.38·10<sup>6</sup> Pa) as lower limit and 600psi (4.14·10<sup>6</sup>Pa) as upper limit, the recommended WOB window for a 4inch (101.6mm) diamond impregnated hole saw reads:

$$WOB_{lower} = 200\pi(4t - t^2) \tag{2.22}$$

$$WOB_{upper} = 600\pi(4t - t^2) \tag{2.23}$$

Figure 2.15 shows the WOB window, where Eq. (2.22) and (2.23) determines the limits for a given hole saw thickness.

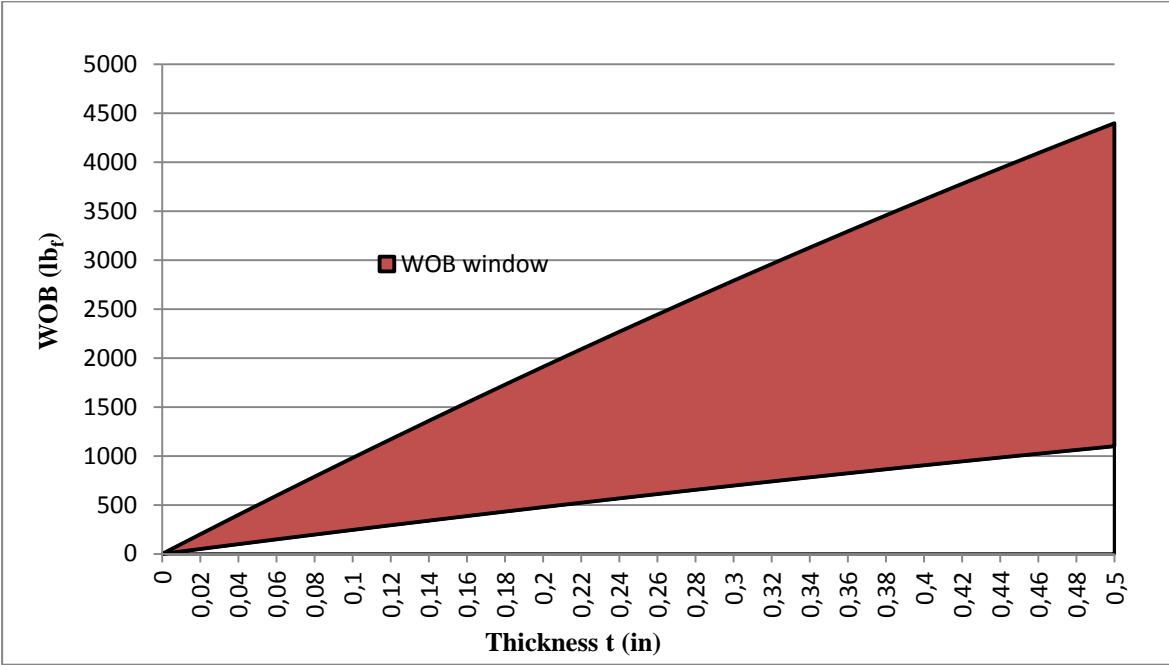

**Figure 2.15 – Optimal WOB window for diamond impregnated hole saws as a function of the wall thickness (t) of the bit. This is based on the theory that the diamond bits work best when it exerts between 200 psi and 600 psi on a steel target**

The SXDS (see Figure 2.16) from Shortbits and Tools has 30-40 mesh diamond grit and is one of the thinnest petroleum graded diamond impregnated hole saws available on the market. Given that the SXDS has a thickness of 0.25in (6.35mm); it means that the optimal WOB window is between 589lb<sub>f</sub> (2622N) and 1767lbs (7866N) (see Figure 2.15). The DDR was considered to work best in the lower part of the window before the tests had started.



**Figure 2.16 - SXDS bit. It is a diamond impregnated bit, which has been proven to work well on coiled tubing steel-milling operations**

To reduce the WOB window further, a bit had to be adopted from another industrial area. The thinnest diamond core bits made are found in the construction industry. They are made by completely different fabrication methods, where the diamond segments are laser welded onto an extremely thin wall tube.

These are mass produced and cost much less than petroleum graded diamond hole saws. While petroleum graded diamond hole saws have a minimum thickness of 0.25in, these bits are available with thicknesses down to 1/16in (1.59mm). For the thinnest construction bits the WOB window is lowered to be between 154lb<sub>f</sub> (688N) and 464lb<sub>f</sub> (2065N) (see Figure 2.15). This is an enormous difference, which means that the required torque would be much lower, and that the thin bit could most likely complete the job faster. However, an in-house test at the production facilities of Short bits & Tool Co. showed that the thinnest bits worked well for cutting steel, but that they were too weak to handle the loads. The impregnated segments used in such bits are free-standing matrixes with no internal supporting steel and the tube materials they use are nowhere close to oilfield standards. For these reasons the segments will bend easily and possibly prevent further progress (Brad Beggs et al., 2014).

As an experimental bit, a construction bit with a thickness of 0.175in, was modified and improved to withstand much higher loads, Short bits & Tool Co called this bit SQDS. The WOB window for the SQDS are between 421lb<sub>f</sub> (1872N) and 1262lb<sub>f</sub> (5617N). Although, these bits were not originally intended to be used for grinding through high alloy steels, a

modified and more robust version was regarded likely to be the best suited option for the low powered rotational motor.

Figure 2.17 shows a plot of the torque requirements (Eq. (2.18)), for both the SXDS and the SQDS at their lower WOB limits provided from Eq. (2.22) as a function of the friction coefficient. The figure also shows plots for the theoretical stall torques depended on the DDR settings described in Figure 2.11.

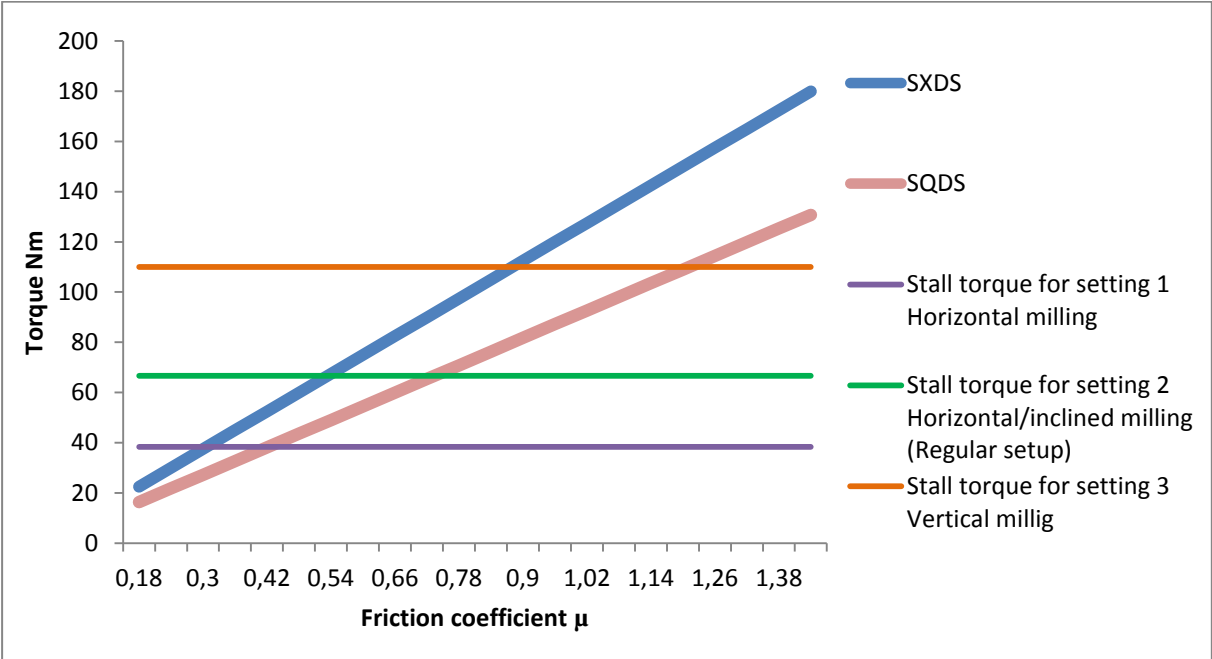

**Figure 2.17 - Torque requirements for the SXDS and SQDS as a function of the friction coefficient ( $\mu$ ) for the lower WOB limit calculated from Eq. (2.22) . As long as the required torque is below the stall torque, which is depended on the DDR setting, the motor will keep turning the bit**





### **3 Test setup and test outline**

In the next part the test setup and procedure of the yard test will be presented. All tests were carried out by the same procedure (see Chapter 3.2) and all tests were carried out by use of the same test bench (see Figure 3.1). But, the tests were carried with two toolstring designs, one for the standard hole saw and another for the diamond bits.

As mentioned in the Chapters 1.4 and 2.3.4 there were only two gearing options available for the tests, 1:1 and 3:1. For the tests conducted with the standard hole saw a 3:1 gearbox was used. The 3:1 gearbox gave a RPM of approximately 60, which was close to the recommended RPM from the bit producer (see Figure 2.14). In addition, previously performed tests have shown that it is not sufficient with a 1:1 gearbox to turn a standard hole saw against steel (Lien, 2014b). As there was no way of controlling the feed rate, the main parameters to discover were at which level of WOB the hole saw performed best with and how the bit performed against high alloy steels.

The tests performed with the diamond bits used a 1:1 gearbox, which gave a RPM of approximately 180. For the test the WOB was adjusted according to the WOB window showed in Figure 2.15.

As there were three bits to be tested, and three alloy steel targets, each bit was be tested on gradually increasing tougher targets. That means each bit started with a steel plate of 13Cr, and then S13cr, before the final target was an Inconel 718 steel plate.

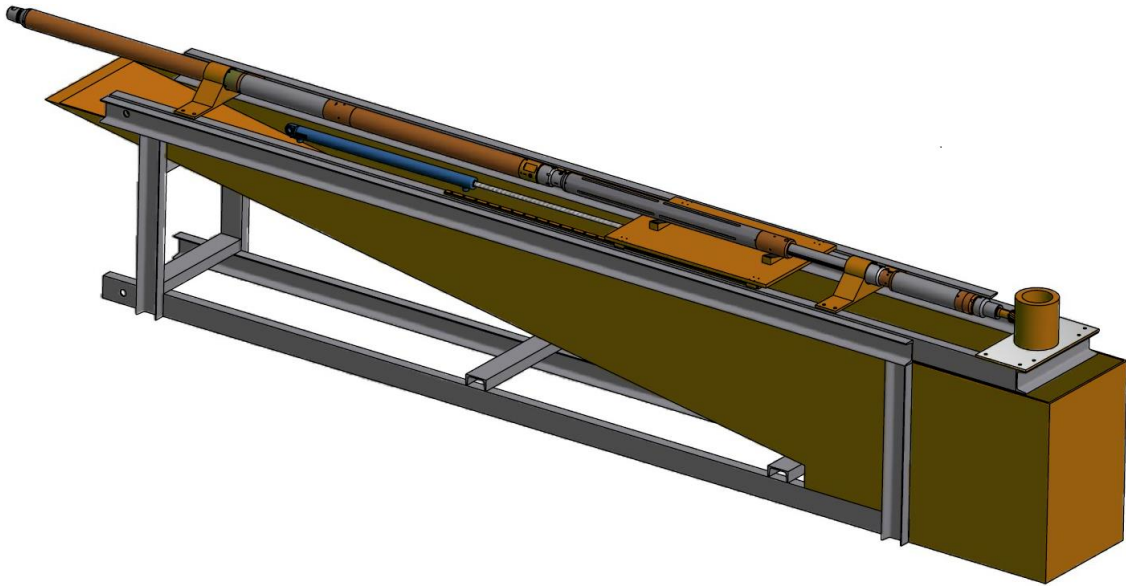

**Figure 3.1 – Sketch of the test bench used for all the tests. By use of a hydraulic cylinder and a pump the entire toolstring, which was mounted to linear guides, could be pushed against the steel plate. A weight cell connected to a computer was placed at the end of the linear guides, logging the WOB data**

### **3.1 Test setup**

The toolstring consisting of the DDR, Shock Absorber, gearbox and bit was connected to a regular PSP and PCP, and mounted in the test bench like showed in Figure 3.2

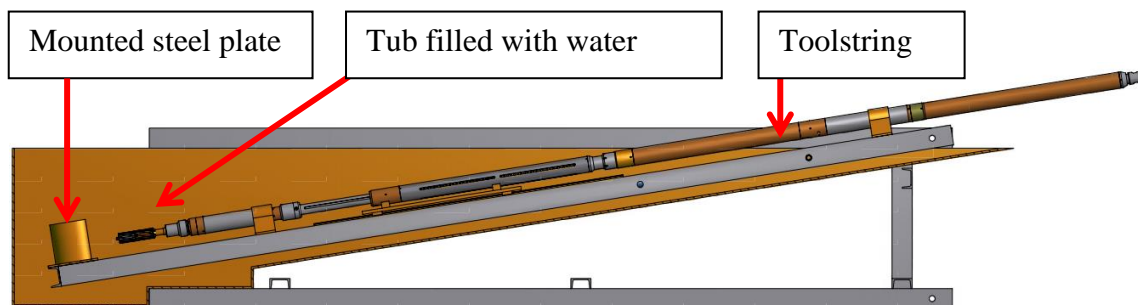

**Figure 3.2 – Test setup. When the entire toolstring was connected, the assembly was lowered into a tub filled with water. This enabled proper cooling both to the bit and to the target material**

### **3.2 Test procedure**

The tests were carried out by the following procedure:

1. Measure length of grinding elements before test (only applicable for diamond bits)
2. Mount work piece in test bench
3. Lower work piece and toolstring into test bench filled with room temperate water
4. Warm up DDR and gradually increase voltage to 450

5. Slowly move bit towards and against work piece
6. Gradually increase WOB
7. If DDR stalls, note stall weight and time of stall, decrease weight and continue
8. When through work piece the current will decrease, note time used for specific work piece and measure length of grinding elements (only applicable for diamond bits) and calculate ROP by use of Eq. (3.1).

$$ROP = \frac{\textit{Progress of bit}}{\textit{Time used}} \quad (3.1)$$



## 4 Results

During the timeline of the thesis there was limited equipment available, and the tests had to be carried out with what was available. Two tests, one with the SXDS bit (see Chapter 4.2.1) and one with the standard hole saw (see Chapter 4.4.1), had to be performed with a DDR with a current limit of only 3A. By assuming a motor efficiency of 0.7 this meant that the DDR was not able to provide more than approximately 50Nm according to Eq. (2.9) with the 1:1 gearbox, and approximately 150Nm with the 3:1 gearbox.

The rest of the tests were conducted with another DDR, which was capable of providing up to 90Nm (270Nm with a 3:1 gearbox) and had a current limit of approximately 5A.

As a precaution, all long lasting tests had to be divided into hourly sessions with long pauses between. This was a measure to secure that the hydraulic oil operating the cylinder (described in Figure 3.1) should not overheat and damage the pump.

### 4.1 Preliminary test with standard hole saw

Before the actual tests were carried out, a preliminary function test of all the equipment was conducted. The test showed that even the centralization provided from the test bench where insufficient when a standard hole saw was used. The saw cut uneven (see Figure 4.1) and the carbide chips would have been broken if the test had not been stopped. The same findings were discovered during full scale tests in 2013 (Lien, 2014a).

During the tests in 2013, the milling operation had to be carried out in two runs. In the first run a regular steel drill bit was used to make a center hole. In the second run the hole saw was used with a center guiding pin mating towards the predrilled hole to help centralize the bit (see Figure 4.4). The results from 2013 showed that drilling small centre holes, i.e. up to diameters of 20mm, through high alloy steels, even Inconel 718, was no

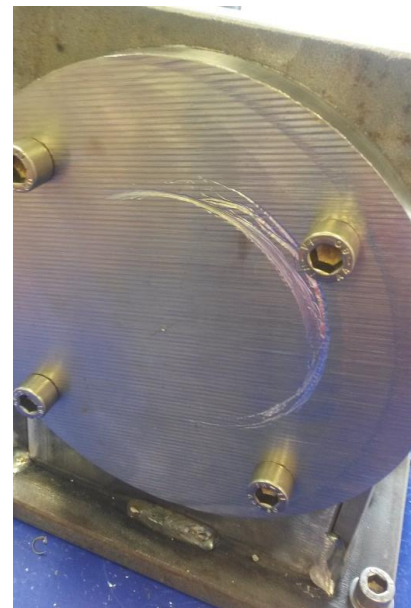

**Figure 4.1 - Steel plate after Preliminary test with standard hole saw. The hole saw was not able to make a clean cut and the test had to be aborted**

problem with a DDR (Spinnangr, 2013). Therefore, all tests conducted with a standard hole saw was from this point forward performed on steel plates with a pre-drilled center hole to save time.

Another important note from the 2013 test report was that it would not be possible to combine the hole saw with a centre drill bit, because of the differences between the tangential velocities of the small drill bit and the large hole saw. The low velocity on the drill bit prohibited the progress of the hole saw and thereby it was not possible to mill trough high alloy steel targets.

**4.2 SXDS test results**

**4.2.1 Target one - 13Cr**

**Table 4.1 – Test results from SXDS on 13Cr steel plate**

Time and date of test	12:00 / 15.05.2014
Bit	SXDS
Plate material	13Cr
Thickness of plate	15.1mm
Gearbox:	1:1
Length of grinding element	11.25mm
Time of stall after contact	14min, 1hr 30min, 1hr 42min, 1hr 46min
Ampere when stall	3.2A
Stall WOB	130kg, 120kg, 120kg, 120kg
Total cutting time	Test aborted after 1hr and 57min
Progress	3.25mm
Length of grinding element after test	10.26mm
Comment	3A current limit on DDR

Table 4.1 shows the tests parameters and summarizes the results from the test. The WOB was gradually increased until the DDR stalled on 130kg. A total of four stalls occurred, before the test was aborted after one hour and 57 minutes. Throughout the test it was experienced a lot of vibrations, and some connections on the test bench had to be retightened several times to keep the test going.

The DDR used on this test had a current limit of approximately 3A. This made it incapable of providing sufficient torque to turn the bit within the optimal WOB window, the minimum WOB limit for the SXDS was 2622N (267.3kg). As a result of this the bit made little progress

and had only made a shallow cut; the shallowest part of the cut was measured to 2.59mm while the deepest was measured to 3.25mm.

Figure 0.1 in B.1 (APPENDIX B) shows a plot of the applied WOB throughout the test. Note that the plot starts on minus 30kg because of the hang weight. Resetting the scale not was possible at the time.

**4.2.2 Target two – S13Cr**

**Table 4.2 - Test results from SXDS on S13Cr steel plate**

Time and date of test	12:00 / 07.06.2014
Bit	SXDS
Plate material	S13Cr
Thickness of plate	16.76mm
Gearbox:	1:1
Length of grinding element	10.26mm
Time of stall after contact	-
Ampere when stall	-
Stall WOB	-
Total cutting time	20min + 9min (test aborted)
Progress	2.01mm
Length of grinding element after test	9.86mm

Table 4.2 shows the tests parameters and summarizes the results from the test. The WOB was gradually increased until 280kg. A lot of vibrations were experienced at this stage. The WOB was therefore increased to 340kg at an attempt to reduce the vibrations. This did not help and the vibrations were getting worse. The WOB was then decreased to 280-290kg, vibrations stayed the same. After 20 minutes the first session had to be aborted, due to connections on the test bench parting.

The connections were retightened before the second session. The WOB was gradually increased to 300kg. Again the vibrations were substantial, and this finally resulted further testing with the SXDS bit had to be aborted.

The bit had a progress of 2.01mm in 29minutes, which means that it had a ROP of:

$$ROP = \frac{2.01mm}{29min/60min} = 4.16mm/hr$$

It is uncertain if the bit would have been able to maintain this ROP over a longer time table. Further tests will have to be carried out by use of other testing methods.

Figure 0.2 and Figure 0.3, found in B.1 (APPENDIX B), shows the WOB plots for the two sessions.

### 4.3 SQDS test results

#### 4.3.1 Target one – 13Cr

Table 4.3 – Results from SQDS test on 13Cr

Time and date of test start	08:00/30.05.2014
Bit:	SQDS
Plate material	13Cr
Thickness of plate	16.75mm
Gearbox:	1:1
Length of grinding element	8.29mm
Time of stall after contact	5min, 1hour and 52min
Ampere when stall	4.8A, 5.1A
Stall WOB	474kg, 330kg (almost through)
Total cutting time	1hr + 54min (including 3 checkouts)
Length of grinding element after test	8.24mm

Table 4.3 shows the tests parameters and summarizes the results from the test. The test was carried out by two sessions. The bit was through the 13Cr steel plate after a total of one hour and 54 minutes.

In the first session the WOB was gradually increased until the DDR stalled at 470kg. To be certain no damage occurred to the bit the WOB was kept at 300-330kg after the stall. With this WOB the current draw was between 3.8A and 4.5A. It went very smoothly, without any significant vibrations. This gave constant swarf generation (see Figure 4.2).

In the break between session one and two (after one hour of milling), the progress was measured to 11.36mm. It was not possible to measure any difference on the length of the grinding elements.





**Figure 4.2 - Swarf generated from SQDS test on 13Cr. The size of the swarf can be described as small grained powder, with a mud-like texture**

After a 40min break the test was initiated again. The WOB was increased to 330kg. The DDR stalled after 52 more minutes of milling. At this stage the bit was almost through the steel plate. The toolstring was then pulled back, before the WOB was gradually increased to 270kg before the DDR stalled again. WOB was decreased and the DDR started rotating again. The WOB was then increased to 310kg before the bit was completely through the plate.

The plate had a thickness of 16.75mm, which means that the average ROP was:

$$ROP = \frac{16.75mm}{\left(1 + \frac{58}{60}\right) hr} = 8.52mm/hr$$

The ROP would probably have been somewhat higher for a second test, when the WOB limitations would have been known and without the three checks during the test.

WOB plots for the two sessions are found in B.2 in APPENDIX B.

### 4.3.2 Target two – S13Cr

Table 4.4 - Results from SQDS test on S13Cr

Time and date of test start	17:00/05.06.2014
Bit:	SQDS
Plate material	S13Cr
Thickness of plate	16.63mm
Gearbox:	1:1
Length of grinding element	8.24mm
Time of stall after contact	-
Ampere when stall	-
Total progress	10.90mm
Total cutting time	1hr + 1hr + 1hr + 1hr + 1hr + 1hr (6hrs total)
Length of grinding element after test	8.14mm

Table 4.4 shows the tests parameters and summarizes the results from the test. The test was carried out in a total of six one-hour sessions. During the first session the WOB was kept between 320kg and 380kg. The current draw was between 3.5A and 4.5A. Some small size swarf powder was constantly generated, but not much and the progress was minimal. After one hour the bit had progressed 2.98mm. There was no significant wear on the bit.

In the second session the WOB was held at 380-400kg. As in the previous session some small size swarf was generated and the progress was minimal. After the second session the total progress was about 4.8mm. There was no measurable wear to the bit.

During the third session the WOB was held at 395-420kg. Some high peaks of the current draw occurred, but overall the current draw was relatively low (3.5-4.5A). After the third session the total progress was 6.37mm. There was still no measurable wear to the bit.

At the fourth session the WOB was held at 410-425kg. The session was very similar to the third. After completing the fourth session (four hours total milling time) the progress was measured to a total of 8.05mm.

During the fifth session the WOB was held at 410-420kg. The total progress was after this session measured to 9.46mm. No measurable wear on the bit was found.

In the sixth session the WOB was between 390kg and 440kg. After this session the bit had a total progress of 10.90mm (see Figure 4.3).

No further sessions was carried out. The necessary data had been collected over a comprehensive milling time. The bit showed approximately constant progress in every session and the bit showed little or no wear. The average ROP for all sessions was:

$$ROP = \frac{10.90mm}{6hrs} = 1.82mm/hr$$

This means that the bit would have milled through the plate in roughly ten hours if the ROP would have stayed the same.

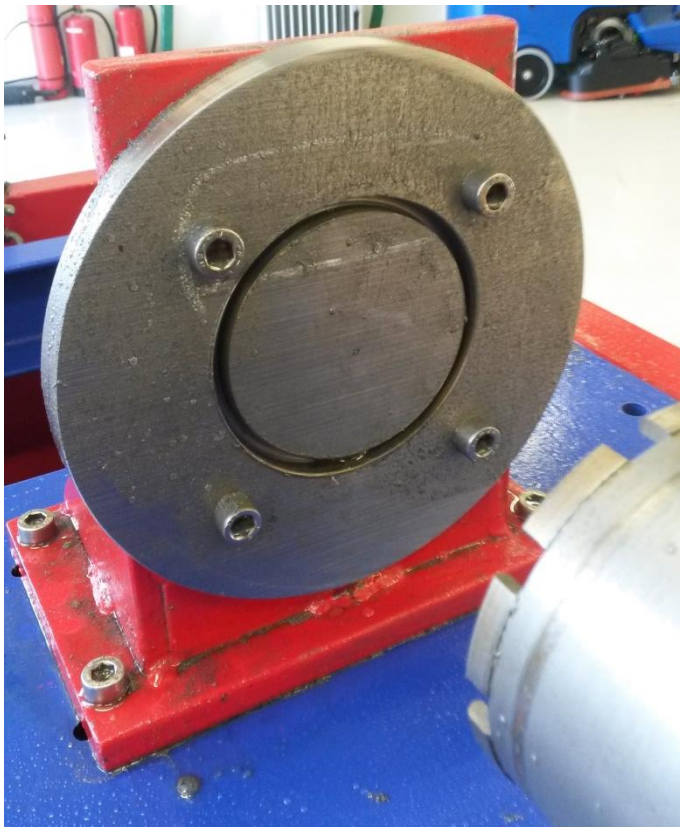

**Figure 4.3 - S13Cr steel plate after six hours of milling with SQDS. The bit showed approximately constant progress throughout the test and very little wear was observed on the bit**

WOB plots for all the six sessions can be found in B.2 in APPENDIX B.

### 4.3.3 Target three – Inconel 718

Table 4.5 - Results from SQDS on Inconel 718

Time and date of test start	09:30 07.06.2014
Bit:	SQDS
Plate material	Inconel 718
Thickness of plate	14.98mm
Gearbox:	1:1
Length of grinding element	8.14
Time of stall after contact	-
Ampere when stall	-
Total progress	2.35mm
Total cutting time	1hr + 1hr + 50min
Length of grinding element after test	7.88

Table 4.5 shows the tests parameters and summarizes the results from the test. The test was carried out in two one hour sessions plus one session of 50 minutes. The last session had to be stopped before one hour had passed, because the temperature of hydraulic oil operating the cylinder (see Figure 3.1) was getting to hot.

When the bit first made contact and during the first minutes, relatively much small sized swarf was generated as the WOB was increased to 380kg. But, this quickly decreased and then only occasionally some swarf was generated. The WOB was then increased to approximately 400kg, where it remained for the rest of the session. After the first session the progress was measured to 1.38mm.

During the second session the WOB was between 420kg and 440kg. The current draw was in the interval between 2.8A and 3.2A, and with few high peaks. After the session the total progress was measured to 2.01mm.

In the third session the WOB was mainly held in the same area as in the second session. Very little, or no, swarf was generated and the current draw remained relatively low. The WOB was drastically increased to 545kg for a short time period to see if this could trigger any progress, but still no swarf was generated. The session was aborted after 50 minutes. After the session the total progress was measured to 2.18mm.

The ROP was declining for every session, and no further progress could be made. Therefore, no further sessions were carried out. WOB plots for the three sessions can be found in B.2 in APPENDIX B.

**4.4 Results with standard hole saw**

**4.4.1 Target one - 13Cr**

**Table 4.6 – Result from standard hole saw on 13Cr steel plate**

Time and date of test start	10:00/15.05.2014
Bit:	Ø100mm Hardline standard hole saw from Karnarsh
Plate material	13Cr
Thickness of steel plate	16.25mm
Gearbox:	3:1
Time of stall after contact	4min
Ampere when stall	3.1A
Stall WOB	100kg
Total cutting time	9min and 10sec
Comments	Approximately 3A current limit on DDR

Table 4.6 shows the tests parameters and summarizes the results from the test. The test was carried out with a predrilled center hole in the steel plate and a pilot guide to help center the hole saw. The WOB was gradually increased until the DDR stalled after 4minutes of cutting and with a WOB of 100kg. The toolstring was pulled back, before the DDR started rotating again and the bit was once again pushed against the steel plate. After the stall the WOB was held at approximately 60kg. After five more minutes, nine minutes total, the hole saw had cut through the 13Cr steel plate. The hole saw showed no signs of wear or damage.

The overall ROP for the test was:

$$ROP = \frac{16.25mm}{(9 + \frac{10}{60})min} = 1.77mm/min$$

Figure 0.12 in B.3 (APPENDIX B) shows a plot of the applied WOB throughout the test. Note that after lowering the assembly in water the hang weight caused a tension on the weight cell, making the plot 35kg less than the real value. Resetting the scale was not possible at the time.

#### 4.4.2 Target two - S13Cr

Table 4.7 - Result from standard hole saw test on S13Cr steel plate

Time and date of test start	15:30/05.06.2014
Bit:	Ø100mm Hardline standard hole saw from Karnarsh
Plate material	S13Cr
Thickness of steel plate	16.80mm
Gearbox:	3:1
Time of stall after contact	-
Ampere when stall	-
Stall WOB	-
Total cutting time	11min and 11sek
Comments	Good progress at 70kg WOB. Low current draw

Table 4.7 shows the tests parameters and summarizes the results from the test. The test was carried out with a center guide and a 3:1 gearbox. Based on the findings made when targeted 13Cr (see Chapter 4.4.1), the WOB was increased to 70kg. This gave good progress and long continuous swarf was constantly generated, shown in Figure 4.4. The current draw was only about 3-3.5A. The WOB was held constant at 70kg throughout the test. After 11min and 11 seconds the hole saw was through the steel plate. It never stalled, and progress seemed to be constant. After the bit was through, the cutaway remained stuck inside the saw and had to be removed with a screwdriver. There was no visible damage or wear to the bit after test.



Figure 4.4 - Standard hole saw through S13Cr steel plate. The core cutaway remained stuck inside the hole saw

Figure 4.5 shows a section of the voltage/current plot from the test just as the bit is getting through the steel plate.

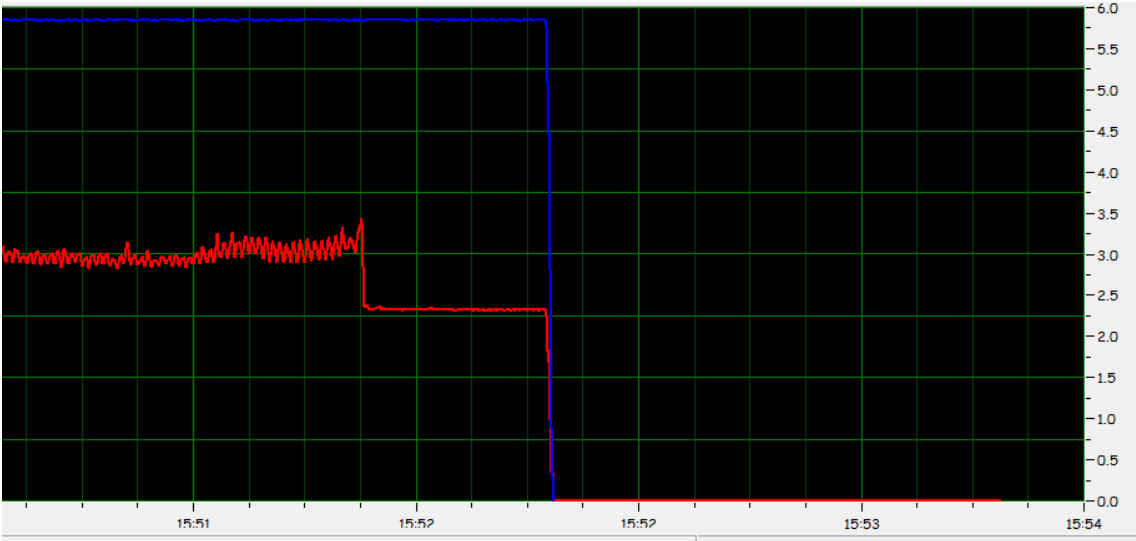

Figure 4.5 - Voltage/Current plot from standard hole saw test on S13Cr steel plate. The current draw (red line) increased some just as the bit went through the plate, and then dropped when it was completely through. The voltage level (blue line) was held at 450V as on all the other tests

The average ROP for the test was:

$$ROP = \frac{16.80mm}{(11 + \frac{11}{60})min} = 1.50mm/min$$

### 4.4.3 Target three – Inconel 718

Table 4.8 - Results from standard hole saw test on Inconel 718 steel plate

Time and date of test start	16:30/05.06.2014
Bit:	Ø100mm Hardline standard hole saw from Karnarsh
Plate material	Inconel 718
Thickness of steel plate	14.97mm
Gearbox:	3:1
Time of stall after contact	-
Ampere when stall	-
Stall WOB	-
Total cutting time	14min and 25sek
Comments	Good progress with high WOB

Table 4.8 shows the tests parameters and summarizes the results from the test. The WOB was increased to 70kg. This gave long swarf. The WOB then dropped to around 40kg. This gave

no progress. The WOB was increased again to 70kg. This helped, but the swarf size was small and not continuous. The WOB was then gradually increased to 135kg, which gave good progress and long continuous swarf. After 14min and 25sec the bit was through the Inconel plate. Again no damage was seen to the bit.

Figure 4.6 shows a section of the voltage/current plot from the test just as the bit is getting through the steel plate.

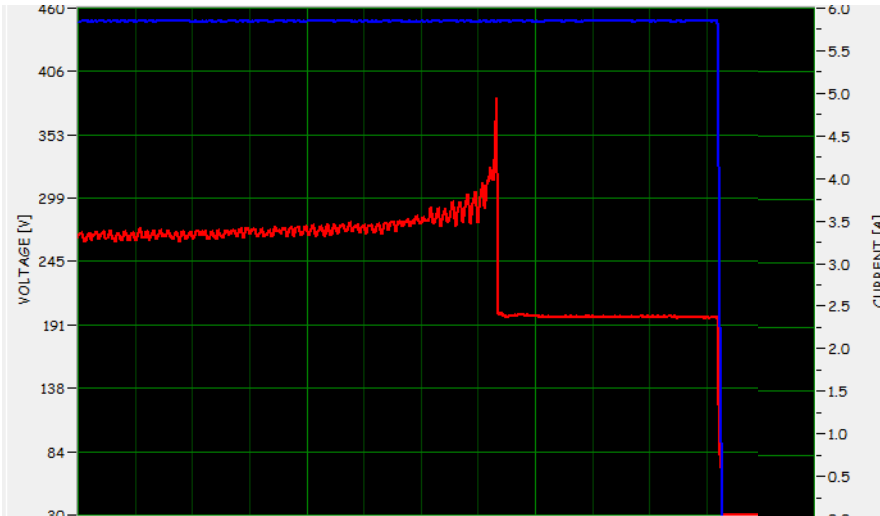

**Figure 4.6 - Voltage/Current plot from standard hole saw test on Inconel 718 steel plate. As seen in Figure 4.5, the current draw (red line) had a high peak just as the bit went through the plate, and then dropped when it was completely through**

The average ROP for the test was:

$$ROP = \frac{14.95mm}{(14 + \frac{25}{60})min} = 1.04mm/min$$

Figure 0.13 in B.3 (APPENDIX B) shows a plot of the applied WOB throughout the test.



## **5 Discussion**

Before going into a discussion regarding the results from the tests, a brief evaluation of the validity of tests will be given. For the tests to have a more scientific approach the test program would have to account for other factors and parameters, like:

- Measurement errors
- Number of tests carried out
- Parameter measurements (e.g. torque plot, rpm measurement, WOB plot combined with torque)

Since most of these factors could not be accounted for within the timeline and because it was not possible to measure all the parameters in the tests bench, the main goal of the tests became to verify if the output power from the DDR was sufficient to mill through high alloy steel obstacles, and to verify how the three bits coped with the targets. The calculated ROPs are rough estimates, meant only to give an indication of what can be expected from the given bits.

Because of late arrival of the test bench, bits and steel plates the test program could not be too comprehensive, otherwise it would not have been possible to complete it within the timeline. However, there are some important findings from the tests carried out.

### **5.1 Bit evaluation**

#### **5.1.1 SXDS**

There is very little data that can be evaluated from the test carried out with the SXDS bit, due to all the vibrations that occurred during the tests that finally resulted in further tests being aborted. Yet, the first test (see Chapter 4.2.1) may indicate that the bit is very depended on reaching its WOB window, or else the progress will be very limited. This also may say that this bit is not a suitable bit to be used together with a DDR that has a current limit lower than 4A, which again will say that horizontal milling operations is out of the question.

The second test (see Chapter 4.2.2), gave an impression that the bit was very aggressive and that when within its WOB window the ROP was quite good, even when dealing with S13Cr. Unfortunately, no conclusions can be drawn from this. It was not possible to complete any more tests.

### 5.1.2 SQDS

In its first test (see Chapter 4.3.1) the SQDS gave promising results when dealing with a 13Cr steel plate. Compared to the SXDS tests, the tests were without any significant vibrations. It all went very smoothly and with swarf generated continuously.

During the second test, when targeting a steel plate of S13Cr (see Chapter 4.3.2), the progress was much less. That being said, the progress was almost constant for all six sessions and if given sufficient time it would have gotten through the steel plate. One important note is that there was almost no wear on the bit, even after 6 hours of milling in hard alloy steel, see Figure 5.1 and Figure 5.2.

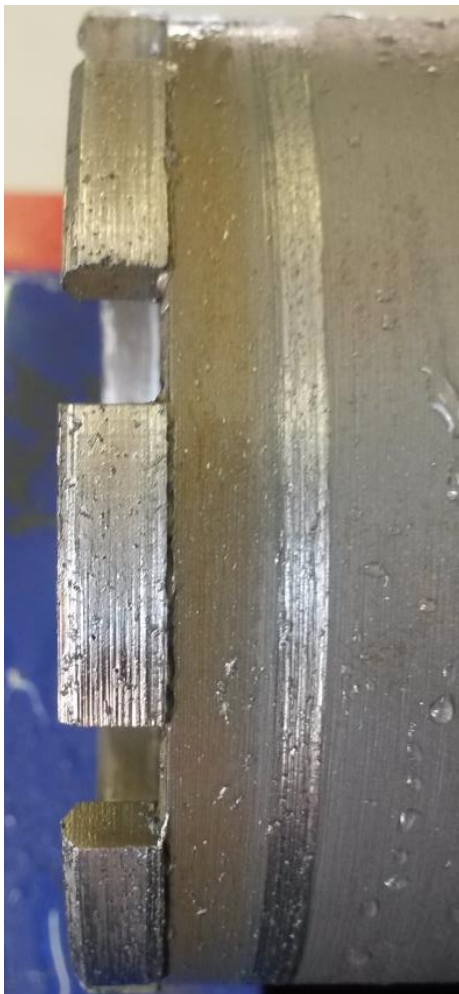

Figure 5.1 - SQDS before S13Cr test



Figure 5.2 - SQDS after six sessions of milling on 13Cr

In the final test, the target was a steel plate of Inconel 718 (see Chapter 4.3.3). After a rather good start the progress rapidly declined. The progress continued to decline until now further progress could be made. Even though there was still no significant wear measured to the bit, it had been worn down more by the three sessions on the Inconel plate than on the rest of the sessions combined. The bit seemed inadequate when dealing with Inconel 718.

The voltage/current plots could indicate that best progress was made when there were significant fluctuations in the current draw. By comparing the plots from the three alloys tests, the plots show a clear difference. When the SQDS was milling on the 13Cr steel plate the current draw had continuous fluctuations (see Figure 5.3), while when milling on S13Cr there was only occasionally some high peaks (see Figure 5.4). During the Inconel test, it seemed like the bit had created a smooth surface on the steel plate, which it just slipped along without making any damage. This was also indicated by a very stable and relatively low current draw, as shown in Figure 5.5.

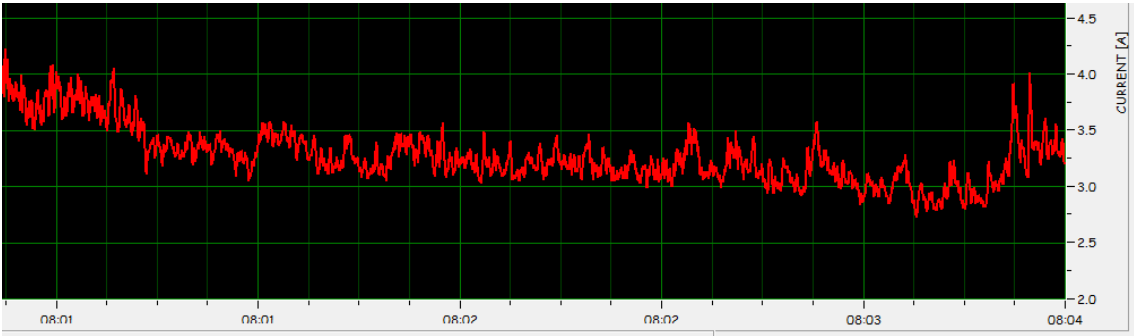

Figure 5.3 - Current plot from 13Cr test

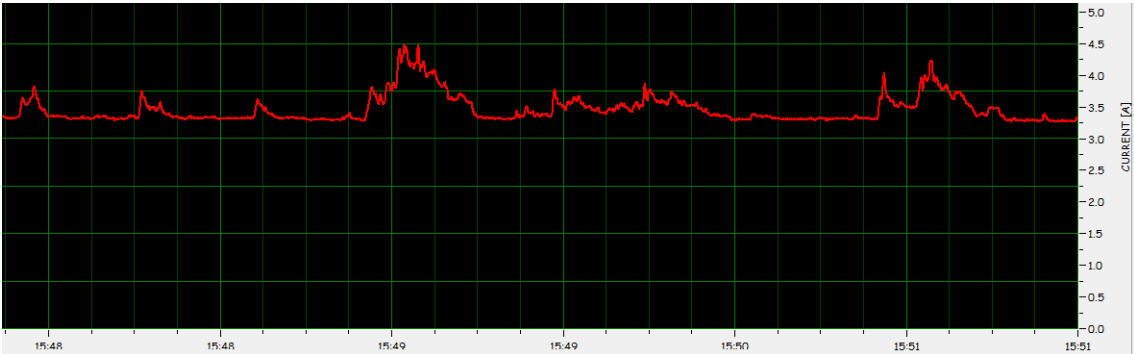
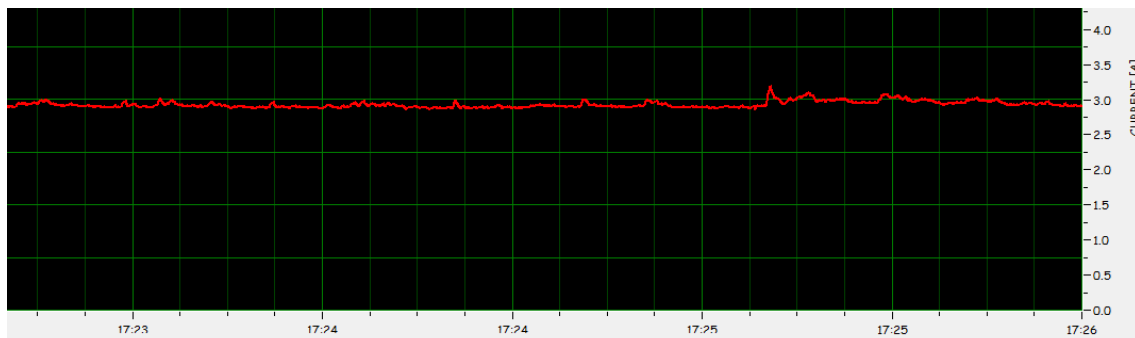

Figure 5.4 - Current plot from S13Cr test



**Figure 5.5 - Current plot from Inconel 718 test**

There was no problem of reaching the WOB window, i.e. the lower limit was approximately 191kg (421lbs) (see Chapter 2.6.2), and it was actually possible to exceed the lower limit by 283kg before stalling. The bit producer (Short, 2014b) recommended that the diamond bits were run at the highest possible RPM while staying inside the WOB window. Therefore, it is likely that the bit would have had a better progress, at least for targets of 13Cr and S13Cr, by use of a gearbox providing higher RPM and lower stall torque. This is definitely something that should be looked into during future tests.

### **5.1.3 The standard hole saw**

The standard hole saw was the only bit to actually mill through all target materials. It completed the cutting quickly and efficiently. But, for this to be a possible solution on a real field operation, each job must be carried out in two separate runs, first with a pilot drill and then with the hole saw combined with a guiding pin. For that reason, there may not be any time saved when summing up the entire operation.

In addition it is unlikely that the bit will perform well without a centralizer near the bit and as mentioned Chapter 2.6 the design it is very vulnerable for impacts. Sudden impacts to the bit may occur while running in hole (RIH), during tagging of obstacles or during the actual milling. If the carbide teeth break off and get stuck in the obstacles, this may prevent or at least limit the potential of success for a second attempt.

To sum up the standard hole saw from Karnarsh is still not thought of as a reliable option. There are three main reasons for this:

1. Carbide teeth may brake of
2. The hole saw is extremely depended on good centralisation

### 3. Need of two runs to complete the task

Yet, the standard hole saw has another advantage over the other options. It may be easier to remove the core cutaway from the well after the operation, as the core usually gets stuck inside the saw and could be secured with the use of a catcher on the guiding pin.

## **5.2 Power limitation**

Although the power available is limited, this does not seem to be a biggest concern for completing the milling tasks. It rather seems like there is toolstring components missing from the portfolio. If the toolstring had worked more like the test bench it would be possible to use a standard hole saw for milling operations, this is discussed further in Chapter 7.1.

Most of the tests were carried out with a DDR that had a current limit of approximately 5A, which turned out to have more than enough power to operate all three bits within their WOB window. This means that for vertical milling the power available should be sufficient. On the other hand, for horizontal milling operations it is more questionable if the power is enough. The test from Chapter 4.2.1 indicates that when the DDR had a current limit of only 3A, it was not able to provide the necessary torque to reach the optimal WOB window for the SXDS. It was however sufficient when milling through 13Cr steel with a standard hole saw.

### **5.2.1 Weight on bit**

The results indicate that even with the limited power available it is possible to mill away obstacles of high alloy steel. Nonetheless, it does not state how this could be transferred to a real milling operation. In truth, at the moment it can be somewhat tricky to apply the required WOB and to stay with in this window throughout the operation.

As discussed in Chapter 2.5.4, it is rather easy to adjust the WOB before a vertical milling operation. The PTA can be set up with rolling anchors and additional weights can be added to reach the intended WOB window. Up until very resonantly, there has been no way of actually knowing what the downhole WOB was. New PTAs are now equipped with tension and compression sensors. This gives field engineers indications of the applied weight, and it will be possible to adjust the WOB by manipulating the winch hold.

In horizontal and inclined operations it is the pull force of the PTA combined with the Shock Absorber spring force that determines the WOB. While the standard PTA has a pull force of 453kg (1000lbs) (Aker Solutions, 2013), this does not mean that it is capable of providing 453kg WOB. It is important to remember that these kinds of operations can occur thousands of meters below surface and that the PTA has to pull the wireline and push the attached tools forward. Any applied winch movement will not be instantaneous at the toolstring. In addition, the actual pull force acting on the toolstring may not be the same as read on the load cell of the winch, due to friction forces acting on the entire length of the cable. As the test results indicates it is very important to apply optimal weight. By having the PTA and the Shock Absorber in combination with the winch as the only WOB control this could be proven difficult. It is possible to add pull force to the PTA by attaching extra drive sections. It is on the other hand important to remember that a PTA on full power has a current draw of approximately 6.6A, which means less power to the DDR.

## 6 Conclusion

From the tests it can be concluded that the standard hole saw, i.e. in combination with a guiding pin and a predrilled centre hole, is capable of cutting through steel plates of 13Cr, S13Cr and Inconel 718 with the power provided from the DDR. It can also be concluded that the DDR is strong enough to operate both SQDS bit and the SXDS bit within their optimal WOB windows. The SQDS bit was found capable of milling through steel plates of 13Cr and S13Cr, but it did not turn out to be suitable for obstacles of Inconel 718. There were too few tests carried out with the SXDS bit to make any conclusion regarding what it is capable of, but judging from the impacts it made on the S13Cr steel plate it should be tested further with another test setup.

To sum up, the DDR is strong enough to mill through stuck valves made of high alloy steels and there does exist bits which is suited for this, but there are still toolstring components missing from Qinterras portfolio to be able to carry out some of the actual operations, like:

- A device capable of providing WOB control
- Full-bore centralization or addressable anchors combined with a stroke possibility





## **7 WOB control proposal and future work**

### **7.1 WOB control proposal**

Weltec, Qinterra Technologies' main competitor, has modified their Stroker to provide WOB control (Joyce, 2009). Qinterra Technologies has not pursued the same modification. Their Stroker is designed for pushing and pulling with accurate weight control and it was not designed to take up any torque. In addition, it is very over-dimensioned to be used in milling operations. While the Stroker has a bidirectional stroke force of 16.1tons ( $\approx 35\,500\text{lbs}$ ) (Aker Solutions, 2013), will no tractor milling operations ever have any need for or the ability to utilize a WOB of this level.

To modify the Stroker to be used for milling operations would mean a very comprehensive redesign, it would consist of many parts, be complicated and very expensive. For that reason a quick fix design solution for pre-selecting the WOB is presented. This is just meant as a concept and a lot of engineering and testing remains before this could be a released product. The suggestion involves two new toolstring components. The first component is a modified gearbox (see Figure 7.1), which should be capable of providing a 30cm (11.81in) stroke length with up to approximately 2900N ( $652\text{lb}_f$ ). The second component (see Figure 7.2), called the Bit Push Unit (BPU), will transfer rotation and weight applied from the modified gearbox to the bit.

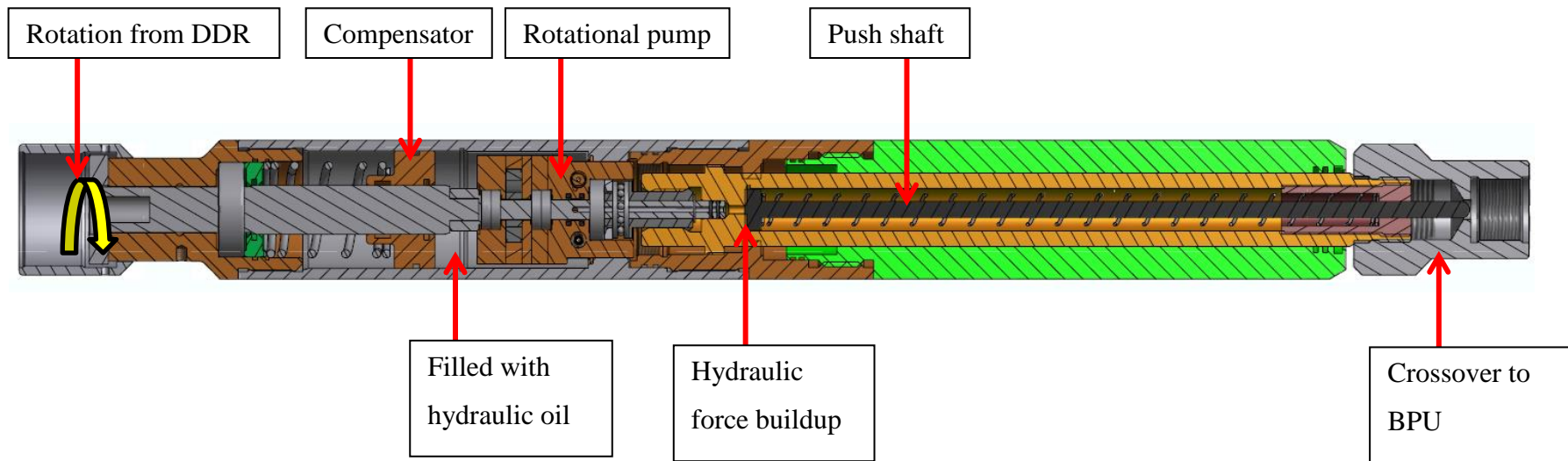

**Figure 7.1 - Modified gearbox. In this design the regular gear has been replaced by a rotational pump. From the rotation provided from the DDR, the pump is able to build up a hydraulic pressure, which acts on the push shaft. The push shaft strokes towards the next component and applies WOB**

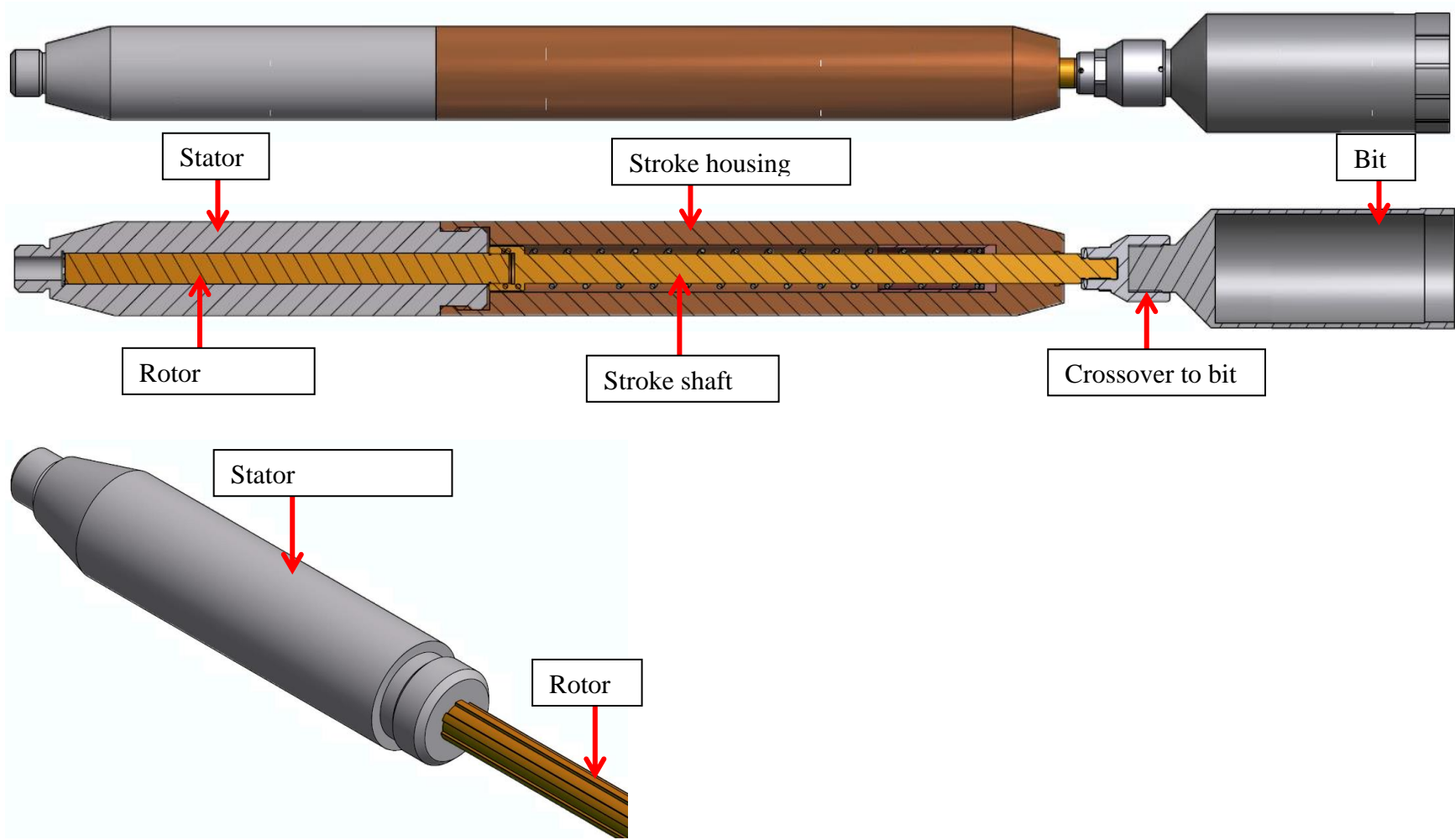
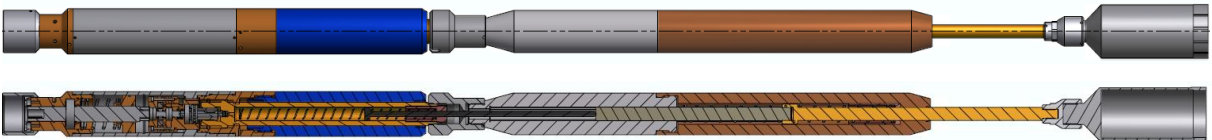

Figure 7.2 – Bit Push Unit. The stroke from the push shaft (see Figure 7.1) acts on the rotor and stroke shaft, which again pushes the bit towards the target

The new concept utilizes an existing rotational pump design that fits inside the gearbox, and with the rotation provided from the DDR it can deliver up to 60bar (870psi). Changing the pressure is possible by adjusting a relief valve inside the pump. The pressure will build up a hydraulic force acting on the push shaft. The cavity to the left (see Figure 7.1) of the rotational pump is filled with hydraulic oil. A compensator aids in maintaining pressure throughout the stroke, by constantly supplying oil to the pump. The spring is added to keep the push shaft in place when no rotation is applied. The diameter of the push shaft at the hydraulic build-up spot is 25mm (0.9843in), and with a pressure 60bars this gives a potential weight on bit of:

$$WOB = PA = 60 \cdot 10^5 \cdot \frac{\pi}{4} \left( \frac{25}{1000} \right)^2 = 2945N$$

This calculation neglects both the spring force acting on the push shaft and the friction force. This will not have a significant impact of the potential WOB, but it will gradually reduce the applied WOB to some extent. It is possible to add more WOB, but then the diameter of the push rod would have to be increased. But, there is not much space left in this design and increasing the diameter of the push rod could potentially mean that the OD of the entire tool has to be increased. In Figure 7.3 both toolstring components are represented in an activated position.



**Figure 7.3 - New WOB control solution. Rotation is transferred from the DDR, through the modified gearbox and to the crossover to BPU. The push shaft in the modified gearbox (Figure 7.1) does not rotate, it only provides a stroke, but the crossover to BPU provides rotation to the stator (see Figure 7.2). The rotor will rotate because of the splined connection with the stator. Rotation and stroke is thereby transferred to the stroke shaft, which applies both rotation on bit and WOB**

The new toolstring design could possibly look like Figure 7.4.



**Figure 7.4 - Future toolstring design.** Compared to the toolstring design presented in Chapter 2.3, the Shock Absorber is removed, and the new WOB control solution is attached directly under the DDR. The toolstring will still be in the need of a good centraliser, as close to the bit as possible

## 7.2 Future work

While the tractor milling technology may not yet be fully mature to take over for all coiled tubing milling operations, it shows a lot of potential. Future developments could drastically increase the tractor milling capabilities, like:

- Addressable expandable centraliser or addressable anchors
- Adjustable downhole WOB with stroking possibilities
- Real-time monitoring of downhole parameters
- Stronger motors

There is an ongoing R&D project for the development of a more advanced and powerful milling tool, called the PowerTrac Driller. The Driller will have a 5kW motor, be able to set anchors to the tubing wall, combined with a surface controlled stroke and it will have the ability to adjust and monitor the WOB in real-time. It is uncertain when this tool will be ready for field operations, but when it is it will be a big step in the right direction.

In addition, there is a need of more scientific tests, to document the force requirements throughout the milling process. Quinterra Technologies is on the verge of producing a second milling test jig, capable of simulating up to 5kW DC motors, where all parameters can be adjusted, measured and logged. By knowing all the required force parameters, it will be easier

to document what the present toolstring is capable of and what it is lacking. This will help set the focus for future developments, shorten the testing timeline and expand the capabilities of the tractor milling technology.

### **7.2.1 Motor opportunities**

The main objective for this thesis was to utilize the motor in the DDR, but the 5kW motor from the PowerTrac Driller does already exist. Even though the Driller is not ready, the motor is more or less ready to be used. To be able to utilize a 5kW motor there are some issues that have to be mitigated. In Chapter 2.5.5 it was stated that the maximum available bottomhole effect provided with today's setup is 3.75kW. So, as for now there is really no point in using a 5kW motor, since there is no way of utilizing its full capacity. However, for another prototype tool there have been successful tests using a 600V and 8.3A power supply. This means that it would be possible to have 4.98kW available downhole and that the rotational motor could potentially be run at almost full capacity. Still, if this motor is to be used for milling it needs proper anchoring to the tubing wall. Before the Driller or other solutions, e.g. hydraulically activated rolling anchors, have been finalized this would mean the use of a PTA. As discussed in Chapter 2.5.5 the PTA "steals" some of the energy, and running the 5kW motor on full capacity would therefore not yet be possible.

On any wireline job the entire wireline drum is usually mobilized, even when there is not always a need for the entire length of the cable. By use of a short and low resistance cable, dedicated for milling operations, it may be possible of sending more electrical power to the downhole tools. This could lead to the possibility of running a 5kW motor, or even a 10kW motor at full capacity. It is uncertain of whether or not a shortened cable from one of the existing wirelines can handle transferring electrical power of this level. New or other cables could possibly be implemented for these jobs. If wireline tractor technology is to take over for more of coiled tubing milling operations this is definitely worth having a look at.

The thesis will end with a translated quote from Gerald McNally, senior specialist at Qinterra Technologies, from the book "Fra pianostreng til finstemt brøntraktor" (Pahr-Iversen, 2010):

*"When we first have a tractor, do we need coiled tubing? Coiled tubing is really too cumbersome, too expensive - yes simply too risky that it is suitable."*

## 8 REFERENCES

- AKER SOLUTIONS. 2013. *wireline tractor and tractor applications product catalogue* [Online]. <http://www.akersolutions.com/Global/Subsurface/Traktor%20katalog%20August%202013.pdf>.
- AKER WELL SERVICE 2012a. PowerTrac® Advance™ 318. <https://picasaweb.google.com/110410790703165408534/AkerWellService3DGrafikk?authkey=Gv1sRgCOMF0pyulujNbw#5525603937366493026>.
- AKER WELL SERVICE 2012b. PowerTrac® Direct Drive Rotation (DDR). <https://picasaweb.google.com/110410790703165408534/AkerWellService3DGrafikk?authkey=Gv1sRgCOMF0pyulujNbw#5737910076446774962>.
- BELAYNEH, A. M. 2013. Lecture notes in Well Completion: Part 3 Material selection note. Stavanger: University of Stavanger.
- BRAD BEGGS, RICHARD BEGGS & SHORT, B. 2014. Shop test - 4.150"x3.680" SQDS test report Internal report.
- CENTER FOR INNOVATION IN PRODUCT DEVELOPMENT - MIT CLASS NOTES. 2009. *Understanding D.C. Motor Characteristics* [Online]. <http://lancet.mit.edu/motors/motors3.html>.
- DIASET 2013. Crused carbide core bit. <http://www.diaset.com/products/mineral-core-drilling/core-bits/devils-dread/>; Diaset.
- DUNN, D. J. 2005. *Solid mechanics, tutorial - friction clutches* [Online]. <http://www.freestudy.co.uk/dynamics/clutches.pdf>; Freestudy.co.uk.
- FAMCO 2013. Five bladed junk mill. <http://www.famcomachineshop.com/images/Products/Mills/Originals/1486m.JPG>.
- FARQUHAR, R. A., RATTRAY, F., ANNANDALE, A., REID, A. & GLEGG, S. 2007. Coiled-Tubing Milling of an Incoloy Alloy 925 Safety Valve Flapper in the North Sea. Society of Petroleum Engineers.
- JOYCE, R. H. 2009. Electric Wireline Milling—New Solutions for New Challenges. Society of Petroleum Engineers.
- JUEL, H., RANUM, H., MJAALAND, S., VARNE, T., SOLBERG, D. B. & BJORNDAL, R. 2009. Wireline Tractor Milling Operations From a Riserless Light-Well Intervention Vessel at the High-Temperature Asgard Field. Society of Petroleum Engineers.
- KARNASCH. 2012. *KLS 27/1 Catalogue* [Online]. <http://www.karnasch.de/en/product-overview/tungsten-carbide-tipped-annular-cutter/>.
- LARKINS, B. & MITCHELL, D. 2011. Light Well Intervention Scale Milling Enables Reservoir Access. Society of Petroleum Engineers.
- LIEN, H. 14.05.2014 2014a. *RE: Conversation regarding previous milling tests*. Type to SPINNANGR, M.
- LIEN, H. 15.05.2014 2014b. *RE: Conversation regarding previous milling tests*.
- MCINALLY, G. 2010. User Manual DDR 318.
- NORSOK 2004. M-001 Material selection. The Norwegian Oil Industry Association (OLF) and Federation of Norwegian Manufacturing Industries (TBL).
- PAHR-IVERSEN, E. 2010. *Fra pianostreng til brønntraktor*.
- PESSIER, R. C. & FEAR, M. J. 1992. Quantifying Common Drilling Problems With Mechanical Specific Energy and a Bit-Specific Coefficient of Sliding Friction. Society of Petroleum Engineers.
- PORTMAN, L. & SHORT, B. 2000. Bit and Mill Selection and Design for Coiled Tubing Applications. Society of Petroleum Engineers.
- REGE, M. 19.05.2014 2014. *RE: Conversation regarding DDR setup*. Type to SPINNANGR, M.

- SCHLUMBERGER. 2009. *Effective well control with unsurpassed reliability - Isolation valves* [Online].  
[https://www.slb.com/services/completions/completion\\_products/~media/Files/completions/brochures/formation\\_isolation\\_valve.ashx](https://www.slb.com/services/completions/completion_products/~media/Files/completions/brochures/formation_isolation_valve.ashx): Schlumberger.
- SHORT, B. 31.01.2014 2014a. *RE: Discussion regarding bit selection*. Type to SPINNANGR, M.
- SHORT, B. 02.06.2014 2014b. *RE: Discussion regarding SQDS*. Type to SPINNANGR, M.
- SHORT BITS & TOOL CO. 2014. MDXT Natural diamond. [http://shortbits.smugmug.com/Other/4500-MDXT-S-Oil-States/28740072\\_NZ5TRQ#!i=2440967709&k=72WXk9P&lb=1&s=X2](http://shortbits.smugmug.com/Other/4500-MDXT-S-Oil-States/28740072_NZ5TRQ#!i=2440967709&k=72WXk9P&lb=1&s=X2).
- SPECIAL METALS CORPORATION 2007. Inconel alloy 718.  
<http://www.specialmetals.com/documents/Inconel%20alloy%20718.pdf>.
- SPINNANGR, M. 2013. Internal test rapport - Steel milling Unpublished.
- SVERDRUP STEEL. 2012a. *Grade 420 Modified 13 Cr Stainless* [Online].  
<http://www.sverdrupsteel.com/no/420-modified/>.
- SVERDRUP STEEL. 2012b. *Super 13 Cr UNS S41426* [Online].  
<http://www.sverdrupsteel.com/no/super-13-cr/>.
- TIMMS, A., MUIR, K. J. & WUEST, C. 2005. Downhole Deployment Valve - Case History. Society of Petroleum Engineers.
- WEATHERFORD 2012. Pressure Isolation, Downhole Deployment Valve.  
<http://www.weatherford.com/weatherford/groups/web/documents/weatherfordcorp/wft020170.pdf>: Weatherford.



## APPENDIX A

### A.1. Alternative torque derivation

By using uniform wear theory the torque approximation stated in Chapter 2.6.4.2 may be somewhat different. Consider the same fundamental ring on the contact surface of the bit. Uniform wear theory (Dunn, 2005) states that the wear is constant anywhere and that it is proportional to the pressure times velocity (when rotating). Velocity is  $v$  and the angular velocity is  $\omega$ .

Because  $v = \omega r$ , wear must be proportional to  $p\omega r$ . For constant  $\omega$ , wear is proportional to  $pr$  and  $p$  is proportional to wear/ $r$ . The wear is constant, which means that:

$$p = \frac{\text{constant}}{r} = \frac{c}{r}$$

As earlier the normal force is:

$$dN = p2\pi r dr$$

Substituting  $p=c/r$

$$dN = 2c\pi dr$$

Integrating between inner radius and outer radius:

$$N = \int_{\frac{ID}{2}}^{\frac{OD}{2}} c 2\pi dr = c2\pi [r]_{\frac{ID}{2}}^{\frac{OD}{2}} = c\pi(OD - ID)$$
$$c = \frac{N}{\pi[OD-ID]}$$

When the bit rotates, the friction force acting on the fundamental ring is  $\mu dN$ . This force produces a small torque:

$$dT = \mu r dN = \mu r 2c\pi dr$$

The total torque is obtained by integration between inner radius and outer radius:

$$T = 2\mu c\pi \int_{\frac{ID}{2}}^{\frac{OD}{2}} r dr = \mu c 2\pi \left[ \frac{r^2}{2} \right]_{\frac{ID}{2}}^{\frac{OD}{2}} = \frac{\mu c \pi}{4} [OD^2 - ID^2]$$

Substituting for  $c$ , and since  $N$  is equal to  $WOB$  we get:

$$T = \frac{\mu WOB}{4} \left[ \frac{OD^2 - ID^2}{OD - ID} \right] = \frac{\mu WOB}{4} \left[ \frac{(OD + ID)(OD - ID)}{(OD - ID)} \right] = \frac{\mu WOB(OD + ID)}{4}$$

## APPENDIX B

### B.1. WOB plots from SXDS tests

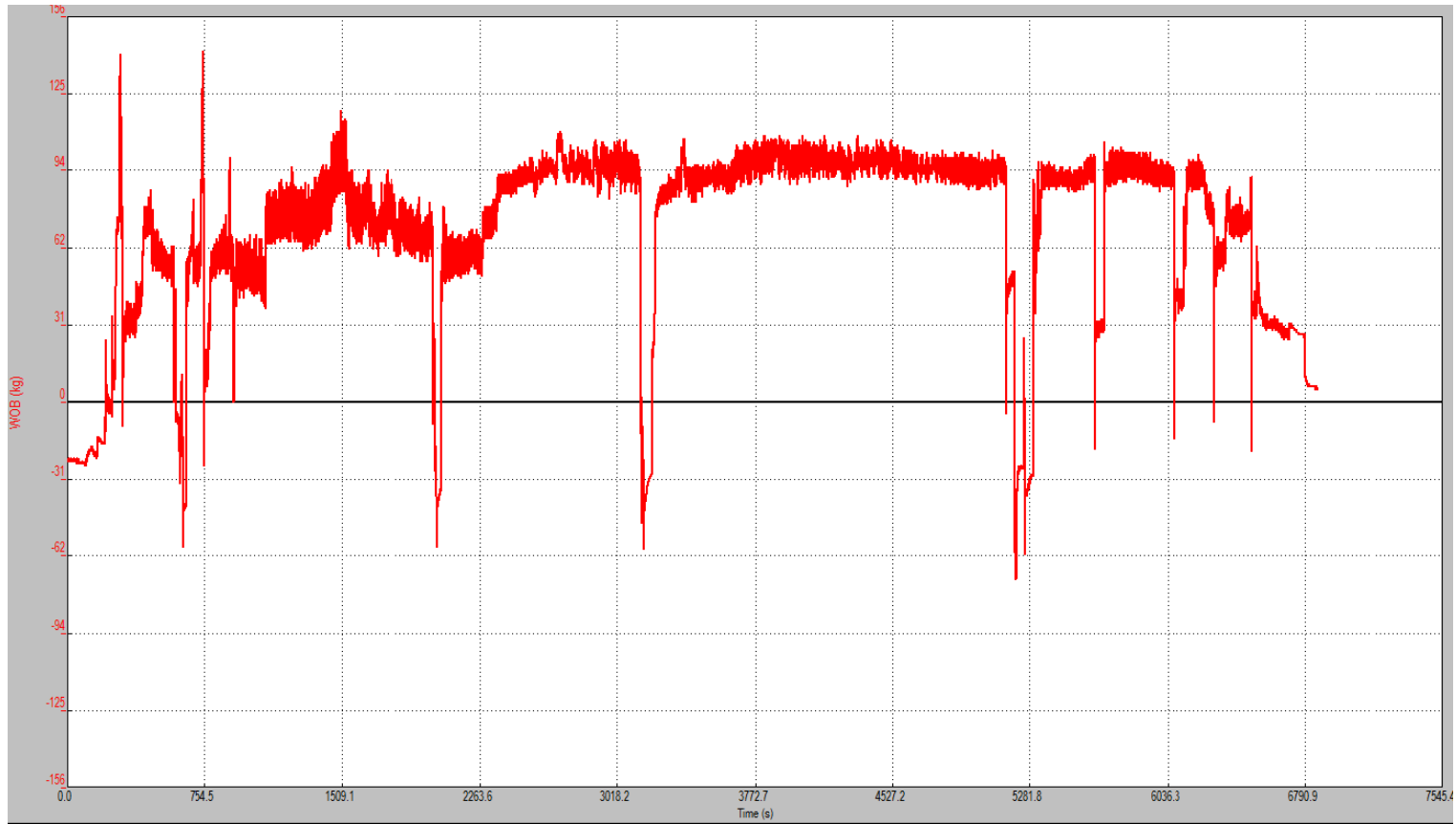

Figure 0.1 - WOB plot from SXDS test on 13Cr

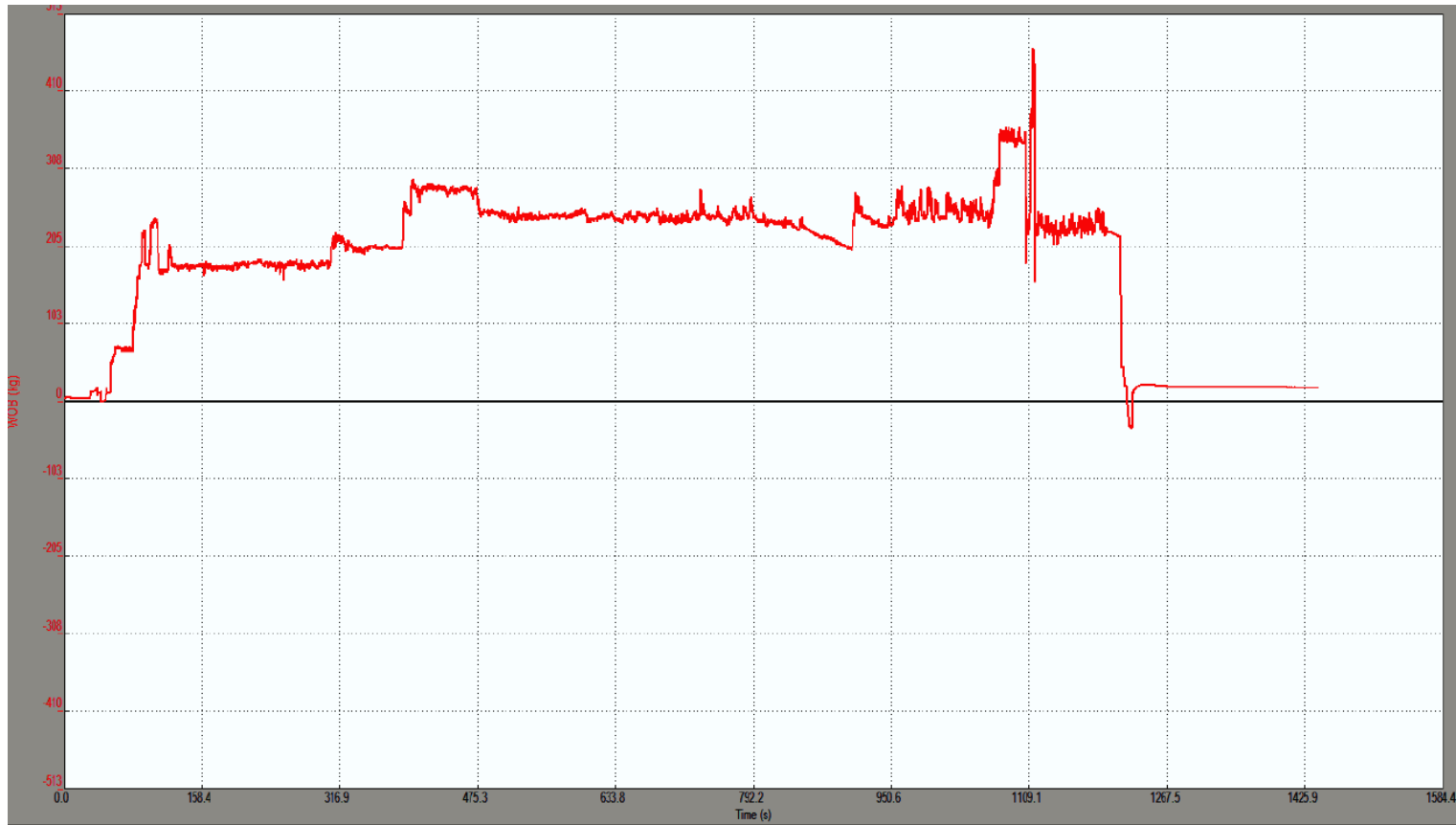

Figure 0.2 - WOB plot from session one of SXDS test on S13Cr

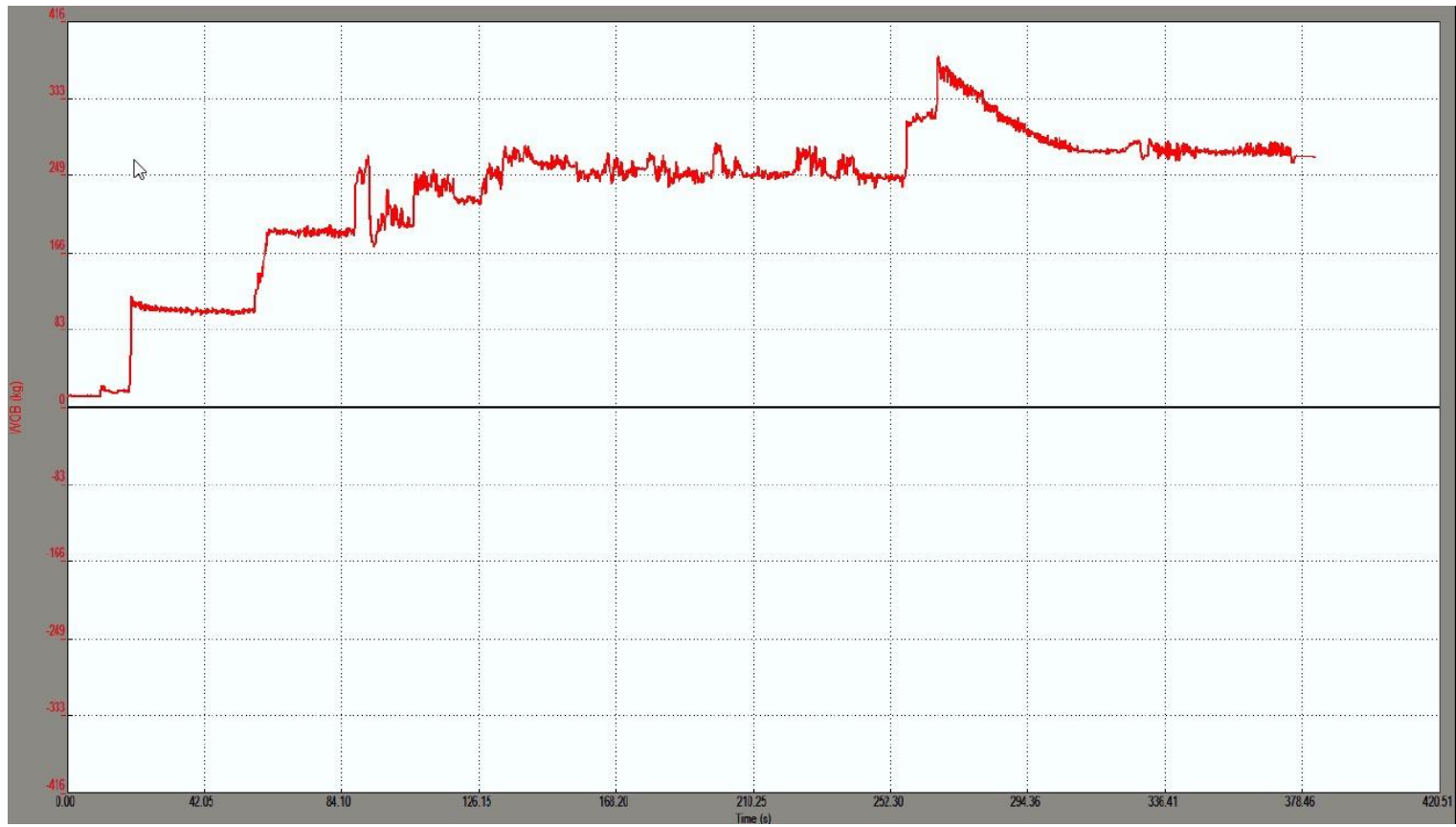

Figure 0.3 - WOB plot from session two of SXDS test on S13Cr

## B.2. WOB plots from SQDS tests

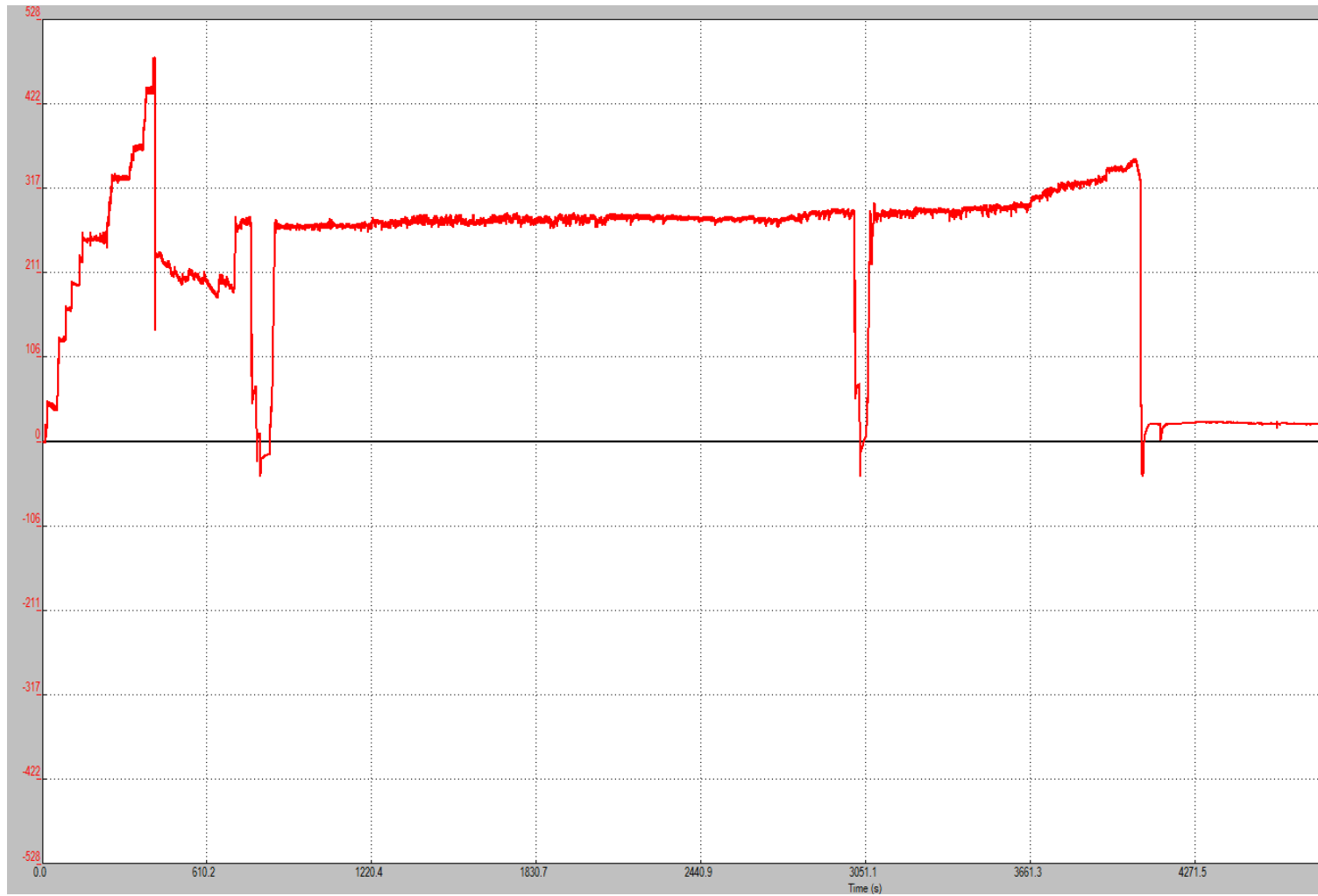
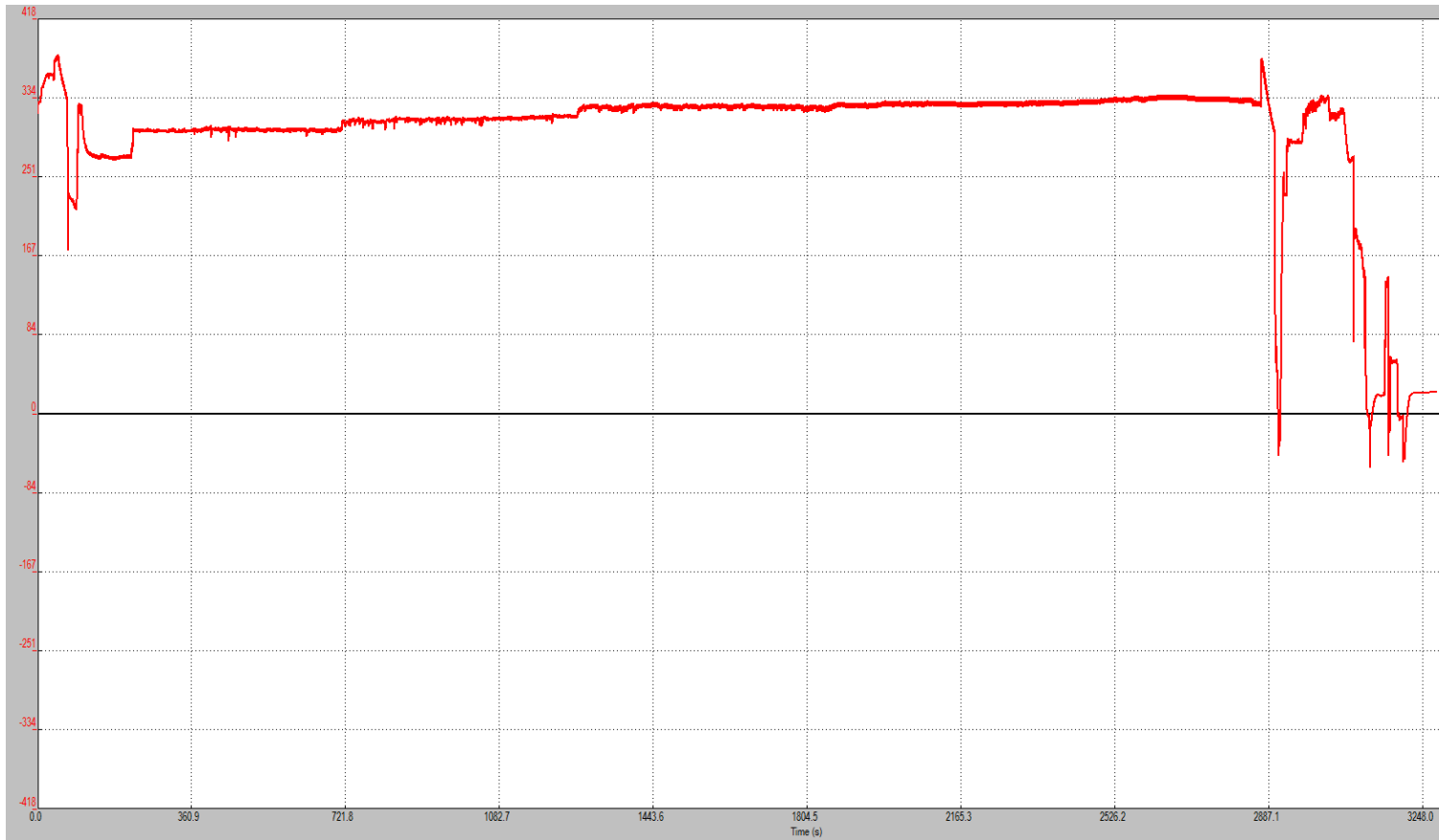
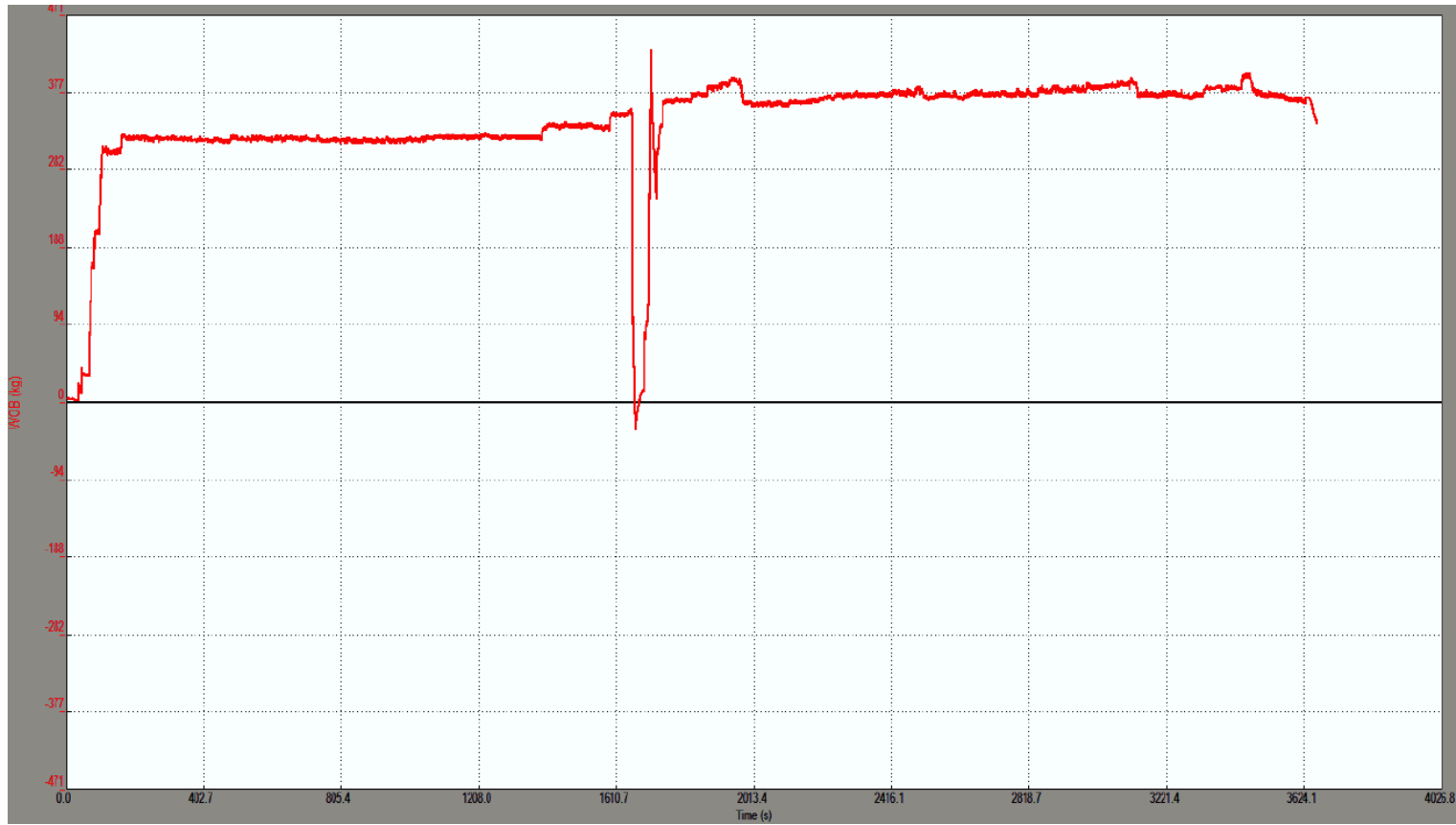

Figure 0.4 - WOB plot from session one of SQDS test on 13Cr



**Figure 0.5 - WOB plot from session two of SQDS test on 13Cr**



**Figure 0.6 - WOB plot from session one of SQDS test on S13Cr**



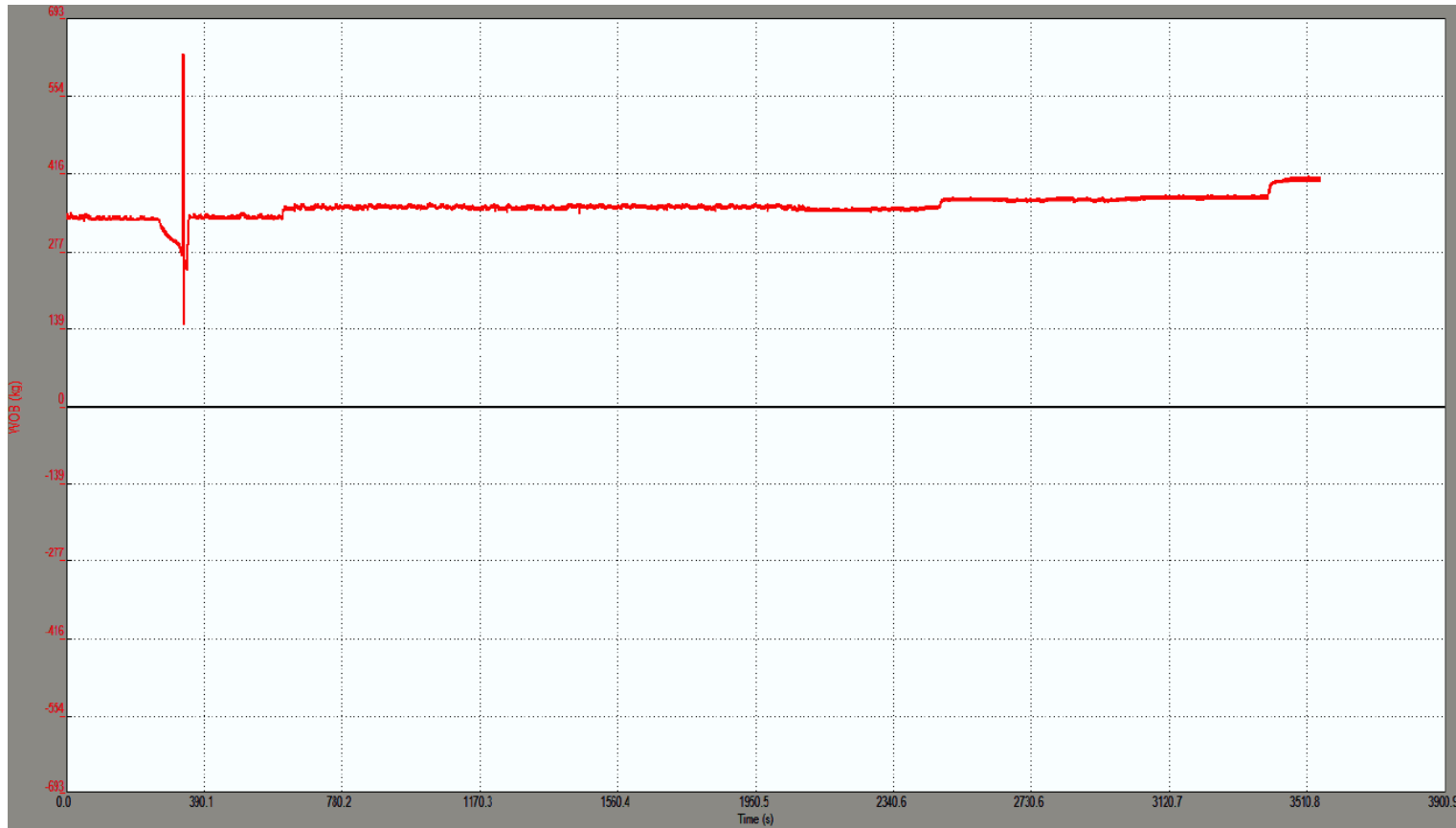

Figure 0.7 - WOB plot from session two of SQDS test on S13Cr

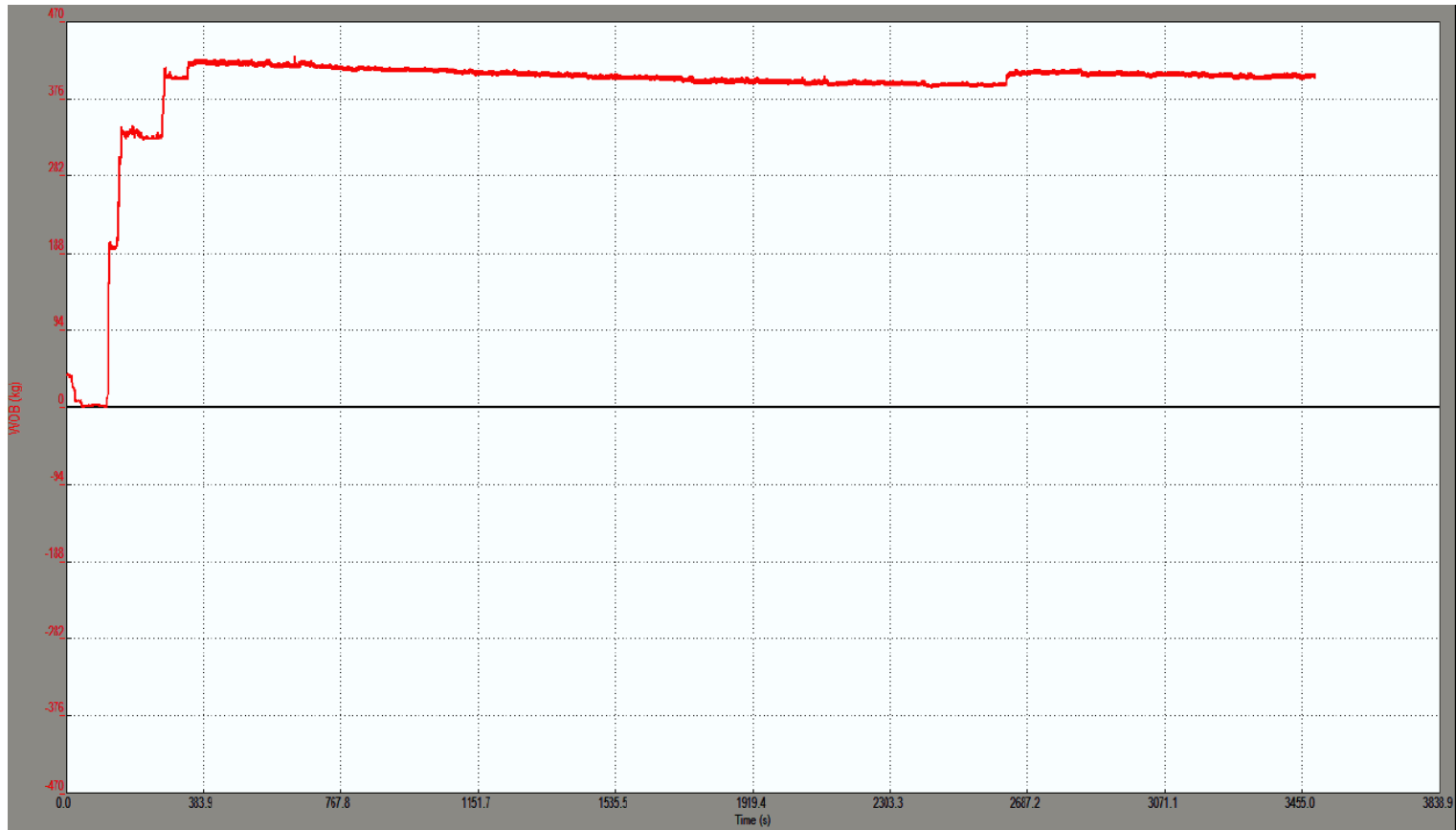

Figure 0.8 - WOB plot from session three of SQDS test on S13Cr

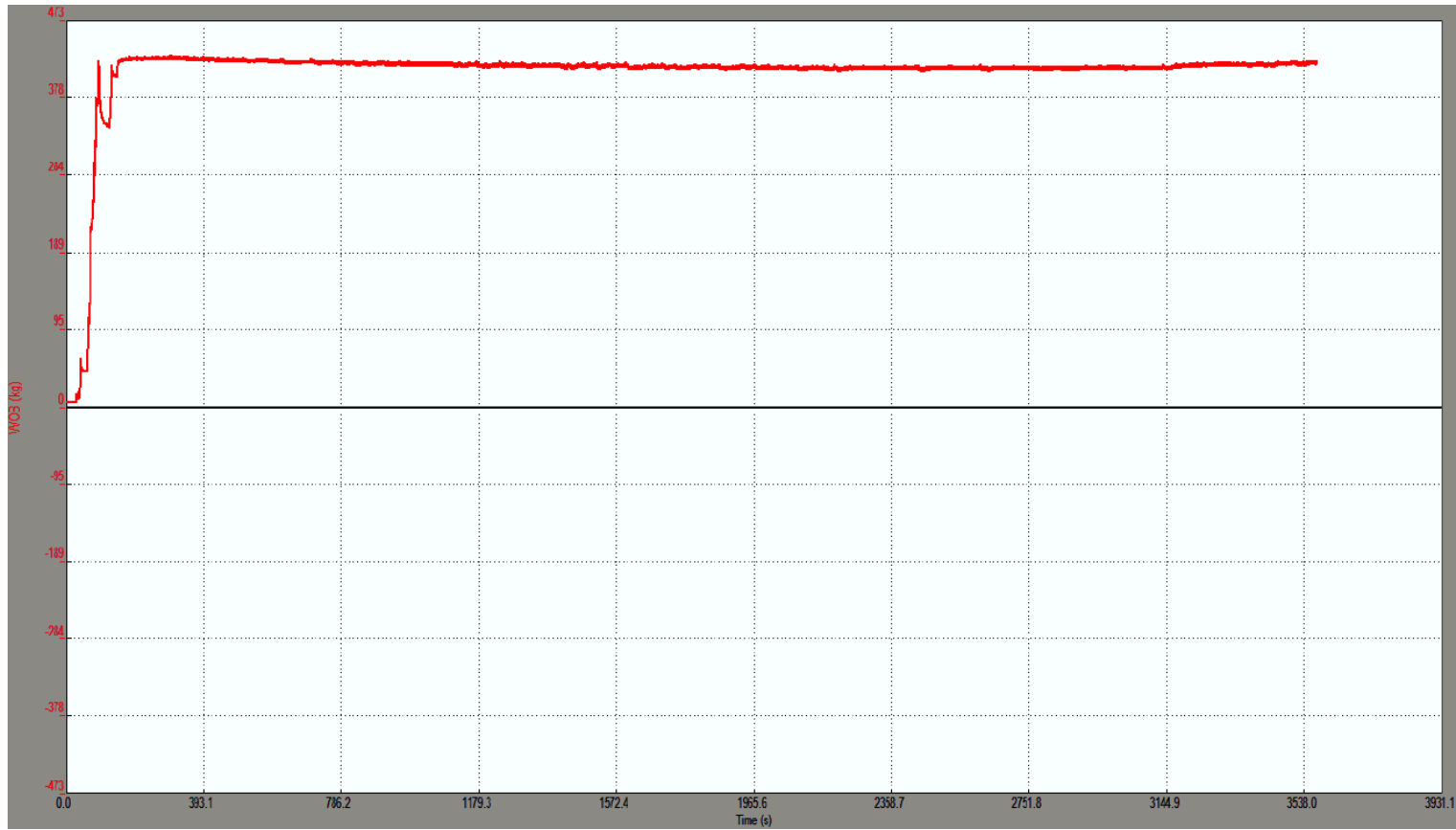

Figure 0.9 - WOB plot from session four of SQDS test on S13Cr

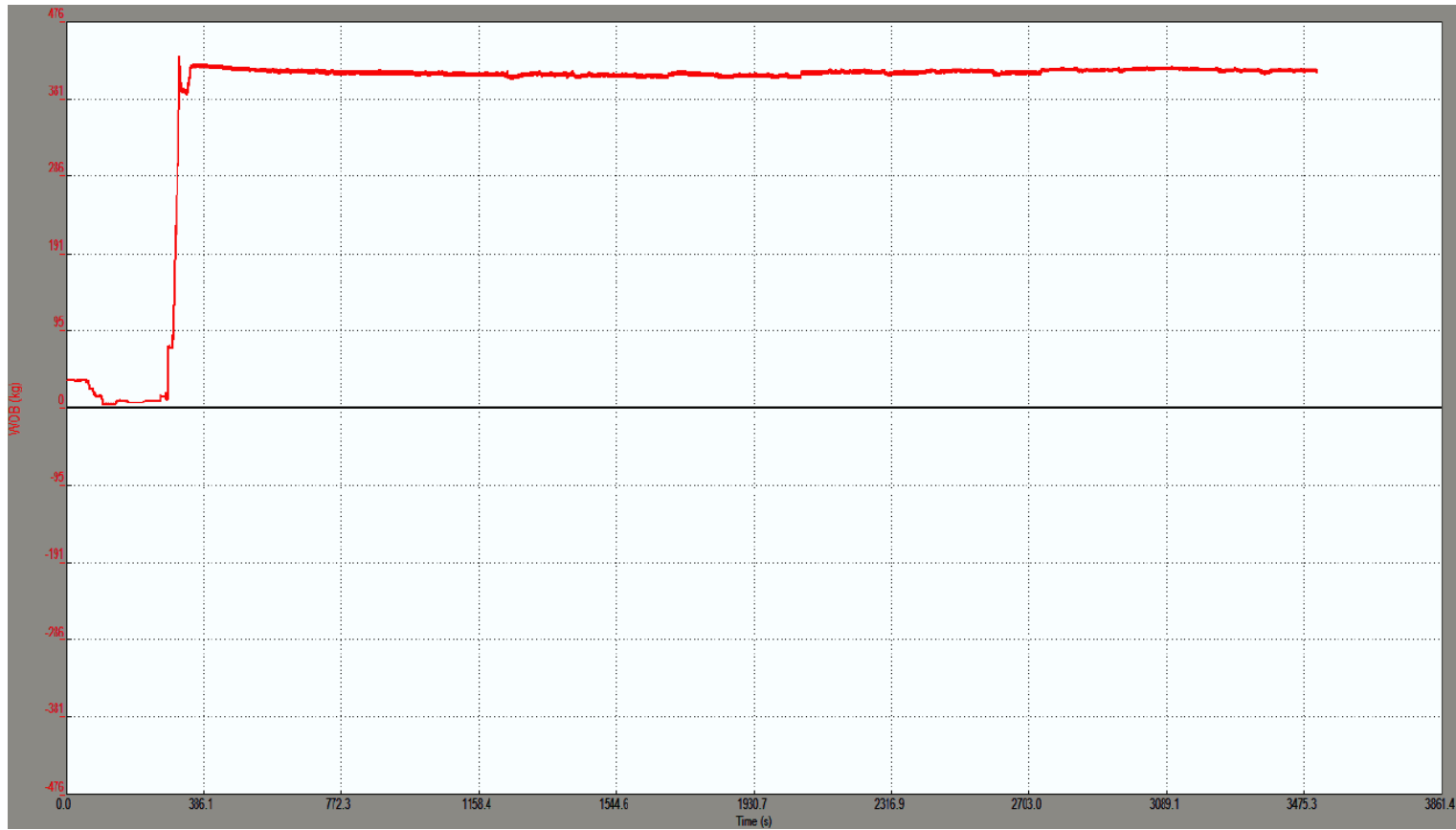

Figure 0.10 - WOB plot from session five of SQDS test on S13Cr

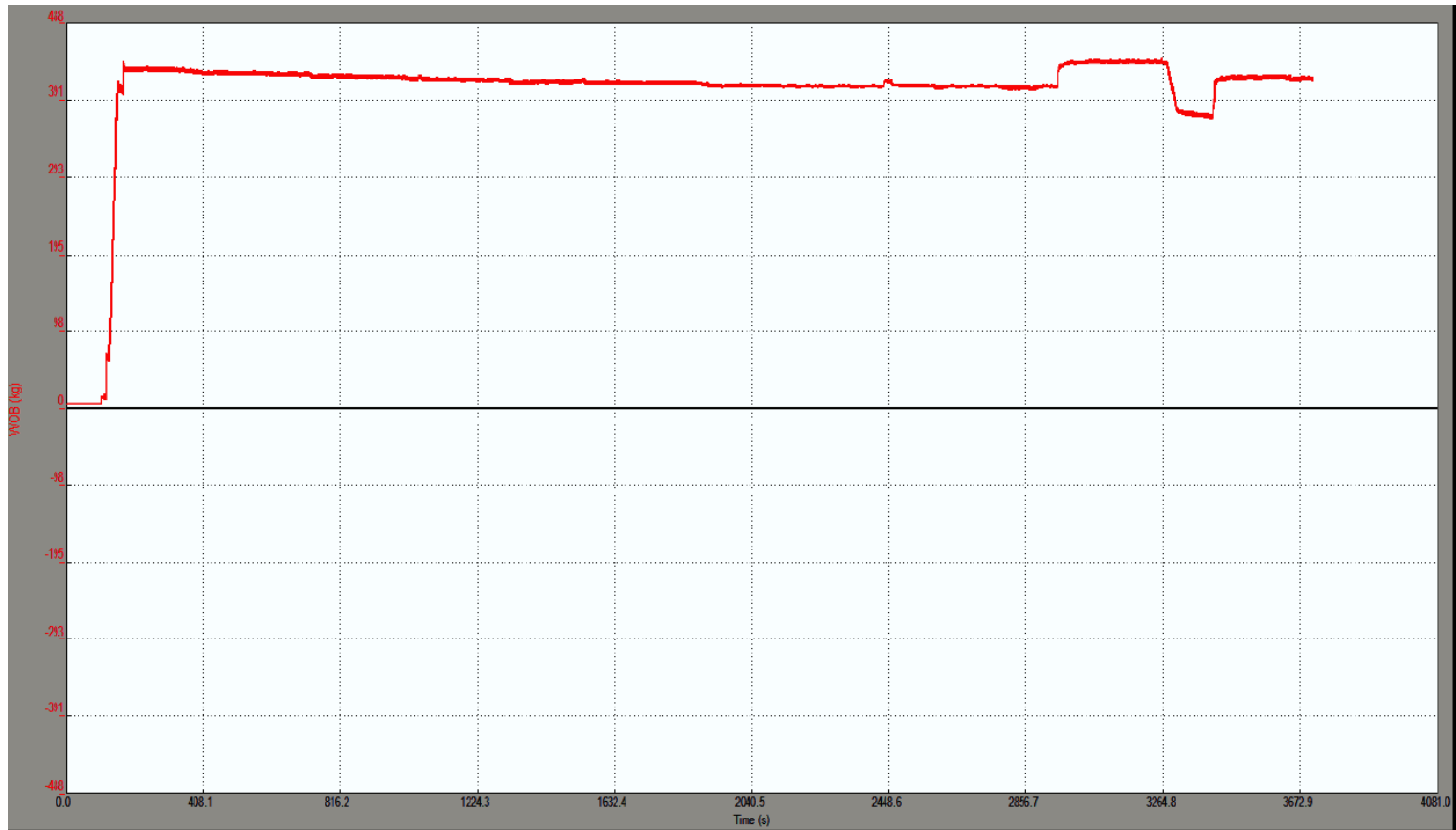

Figure 0.11 - WOB plot from session six of SQDS test on S13Cr

### B.3. WOB plots from standard hole saw tests

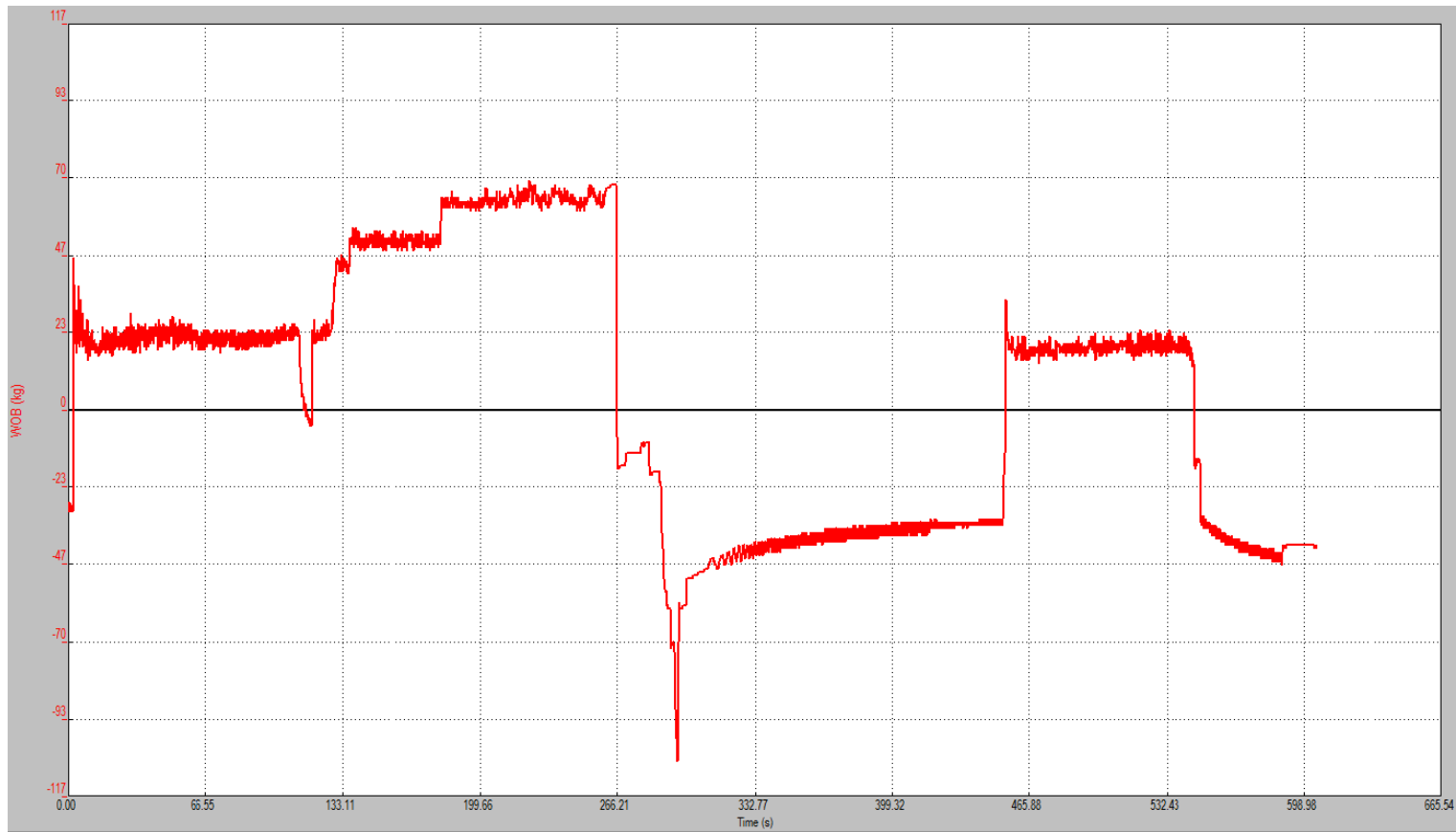

Figure 0.12 - WOB plot from standard hole saw test on 13Cr

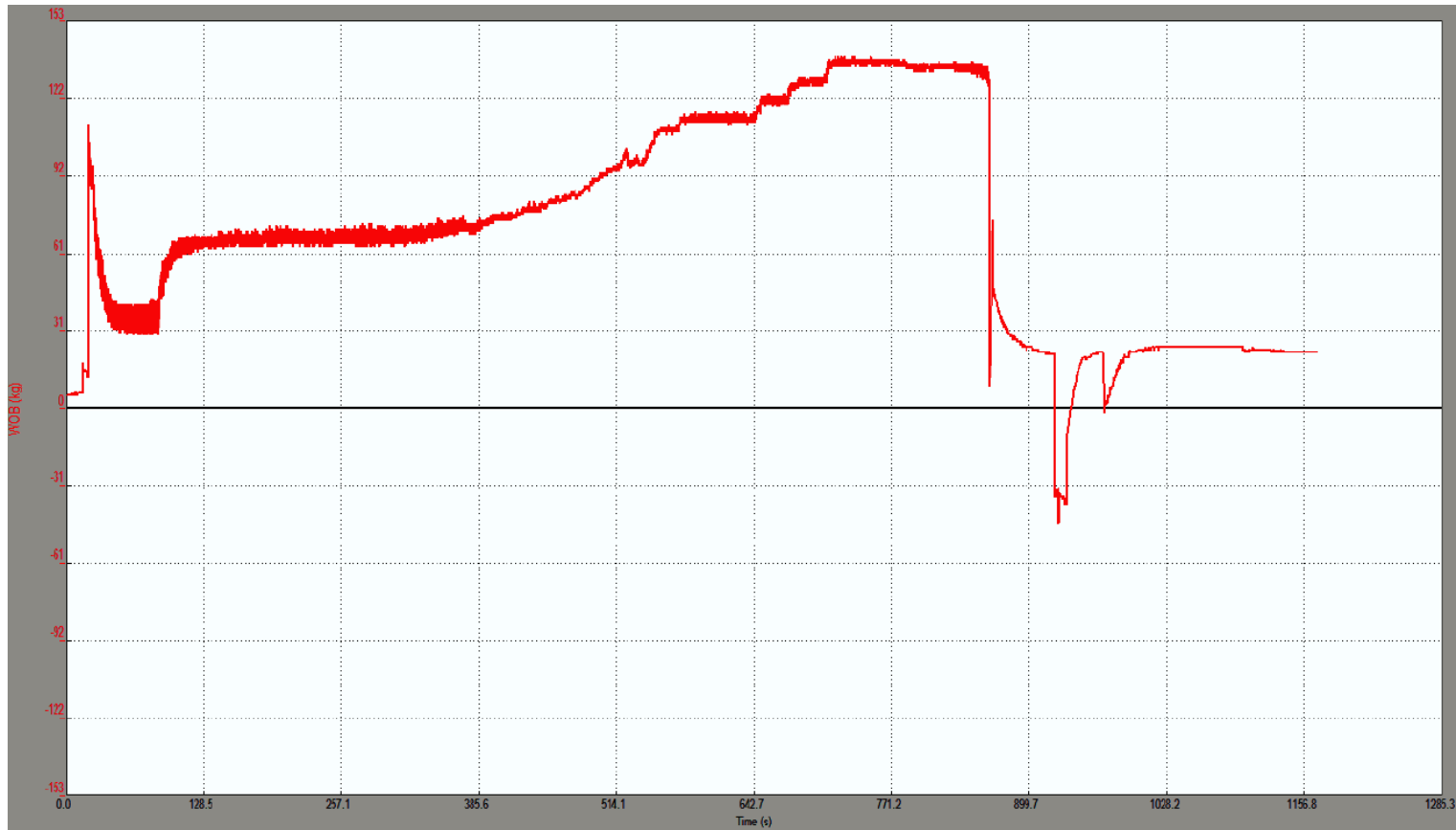

Figure 0.13 - WOB plot from standard hole saw on Inconel 718