



University of
Stavanger

FACULTY OF SCIENCE AND TECHNOLOGY

MASTER'S THESIS

Study programme/specialisation: Petroleum Engineering, Drilling and Well Technology	Spring 2018 Open
Author: Lilja Fure Olafsson (signature of author)
Programme coordinator: Bernt Sigve Aadnøy Supervisor(s):	
Title of master's thesis: Experimental study on thermal effects on well components	
Credits: 30	
Keywords: Fluid properties Inflow control devices Chemical injection valves	Number of pages: 54 + supplemental material/other: 34 Stavanger, 14/6-2018

Abstract

The main objective of inflow control devices is to maintain a uniform inflow by providing an additional pressure loss between the formation and the wellbore. ICDs delay the production of water or gas, and thus increase the reservoir fluid recovery.

The development of challenging oil and gas fields has created an increased demand for chemical injection. Chemical injection enhance production and increase recovery. Some of the purposes of chemical injection is to enhance flow characteristics and quality of oil and gas before transportation, prevent hydrate formation, and prevent deposition of scale, paraffin and asphaltenes.

During chemical injection with conventional valves changes in pressure or temperature results in an inaccurate flow rate. For inflow control devices, coning is delayed but once water or gas breakthrough, production is taken over by the breakthrough fluid. ICDs are thus not an optimal solution when the inflow conditions change as the well matures since they are not adjustable or retrievable.

Autonomous valves account for changes in pressure and temperature. It is achieved by creating a constant pressure differential across a regulation. AICDs restrict inflow of unwanted fluids also after breakthrough by creating a higher-pressure differential.

The aim for the thesis was to examine how the set flowrate on the autonomous chemical injection valves SkoFlo and FloWizard was affected by changes in temperature when injecting water. It can also be implemented for autonomous inflow control devices (AICD) where the valve function is equal. The conclusion from the experiments is that change in temperature causes an insignificant change in flowrate.

Acknowledgements

Lilja Fure Olafsson wrote the master thesis “Thermal effects on well components in the well” during the spring 2018.

I wish to thank my supervisor Bernt Aadnøy for providing the thesis. He has guided me and provided constructive feedback.

I would also like to express my gratitude to Mehmed Nazecic for the experimental set-up and help. In addition, he has been available for questions.

Table of Contents

Abstract	iii
Acknowledgements	v
1 Introduction.....	1
2 Theory.....	3
2.1 Valves	3
2.2 Fluid properties	5
2.2.1 Introduction.....	5
2.2.2 Laminar and Turbulent Flow	5
2.2.3 Fluid properties	6
2.3 Inflow Control Devices (ICDs)	12
2.3.1 Introduction.....	12
2.3.2 Historical Review	12
2.3.3 Advantages	13
2.3.4 ICD Types	15
2.3.5 Limitations of ICDs.....	17
2.3.6 BECH AFD (autonomous inflow device)	18
2.3.7 A Hydraulic Model for the ICD.....	20
2.3.8 ICD and Temperature	22
2.4 Chemical Injection Systems	23
2.4.1 Introduction.....	23
2.4.2 Chemical Injection Systems	23
2.4.2.1 Downhole Chemical Injection	24
2.4.3 Chemical Injection Properties	24
2.4.4 Chemical Distribution System	25
2.4.5 Injection rate control valves.....	26
3 Experimental Method and Results	33
3.1 Introduction.....	33
3.2 Analysis.....	33
3.2.1 SkoFlo	33
3.2.2 FloWizard.....	33
3.2.3 LabVIEW Software System	34
3.2.4 Kärcher K7 Premium Ecologic Home	34
3.3 Method.....	35
3.4 Statistical analysis.....	36
3.4.1 Sample mean	36

3.4.2	Moving average	36
3.4.3	Standard deviation	36
3.4.4	Relative standard deviation (RSD).....	37
3.5	Results	38
3.5.1	SkoFlo	38
3.5.2	FloWizard.....	42
3.5.3	Comparison of SkoFlo and FloWizard.....	48
3.5.4	Reliability of the measurements	49
4	Conclusions.....	51
4.1	Concluding Remarks	51
4.2	Further Work	51
	References.....	53
	Appendix A	55
	Appendix B	79

List of Figures

Figure 1. Needle valve [2].....	4
Figure 2. Laminar, transitional and turbulent flow [4].....	5
Figure 3. Viscosity as a function of temperature [3].....	8
Figure 4. Viscosity and density of water as a function of temperature	9
Figure 5. Velocity profile for laminar flow [3]	10
Figure 6. Variation of shear stress with the rate of deformation	11
Figure 7. Water and gas breakthrough in homogenous reservoir [14].....	14
Figure 8. Uniform inflow profile after installation of ICD in homogenous reservoir [14].....	14
Figure 9. Breakthrough of water and gas in heterogenous reservoir [14].....	14
Figure 10. Uniform inflow profile after installation of ICD in heterogenous reservoir [14]	14
Figure 11. Nozzle-type ICD [16].....	16
Figure 12. PCP valve construction [15].....	16
Figure 13. FloReg™ [22].....	18
Figure 14. Flow rate as a function of pressure drop for BECH AFD [22]	18
Figure 15. Prototype of BECH AFD [22]	19
Figure 16. Typical ICD device [5]	20
Figure 17. Downhole Chemical Injection Valve for Offshore well [25]	24
Figure 18. Chemical distribution system [27].....	25
Figure 19. Haskel valve [24].....	26
Figure 20. SkoFlo [24].....	27
Figure 21. FloWizard.....	28
Figure 22. FloWizard [27]	29
Figure 23. Variations in flow [%] over pressure range 20 - 130 bar [30]	30
Figure 24. Variations in flow [%] in common flow region [30].....	31
Figure 25. FloWizard with internal and external throttling valve	32
Figure 26. HOKE 1335G4Y metering valve [33]	34
Figure 27. Swagelok SS-41GS2 ball valve [34]	34
Figure 28. Experimental setup by Mehmed Nazecic [27]	35
Figure 29. SkoFlo test 1.....	38
Figure 30. SkoFlo test 2	40
Figure 31. SkoFlo test 3	41
Figure 32. FloWizard test 1.....	42
Figure 33. FloWizard test 1.....	43
Figure 34. FloWizard test 2.....	44
Figure 35. FloWizard test 3.....	45
Figure 36. FloWizard test 4.....	47
Figure 37. Comparison	48

List of Tables

Table 1. Density of water at different temperatures [7].....	7
Table 2. Product specifications for HOKE 1335G4Y [33]	33
Table 3. Product specifications for Swagelok SS-41GS2 [34]	34
Table 4. Product specifications for Kächer K7 Premium [36].....	35
Table 5. SkoFlo test 1.....	39
Table 6. SkoFlo test 2.....	40

Table 7. SkoFlo test 3.....	41
Table 8. FloWizard test 1.....	43
Table 9. FloWizard test 2.....	45
Table 10. FloWizard test 3.....	46
Table 11. FloWizard test 4.....	48

Abbreviations

ICD	Inflow control devices
AICD	Autonomous inflow control devices
AICV	Autonomous inflow control valve
PI	Productivity index
PICD	Passive inflow control devices
FRR	Flow resistance rating
RCP	Rate controlled production
DCIS	Downhole chemical injection system
IRCV	Injection rate control valves

Symbols

$q(t)$	flow rate (gal/min)
C_v	flow coefficient of the valve
$\Delta p(v)$	pressure drop (psi)
SG	specific gravity of the fluid
V_{avg}	average flow velocity
D	characteristic length of the geometry
ν	kinematic viscosity
μ	fluid viscosity
ρ	fluid density
β	compressibility
V	volume
P	pressure
c	speed of sound
R	universal gas constant
n	number of moles
T	absolute temperature
M	molar mass
τ	shear stress
F	force
P_{res}	reservoir pressure on the outside of the system
P_2	pressure in chamber after flow setting
P_{tub}	production tubing pressure
x	displacement of spring loaded piston
K	spring constant
K_v	nozzle constant
Q	flow rate
n	number of nozzles
K_f	spring constant [N/m]

x_0	preposition of spring [m]
$x(t)$	compression of spring [m]
A_s	piston surface area [m ²]
$P_i(t)$	inlet pressure [bar]
$P_2(t)$	internal pressure [bar]
$q(t)$	flow [m ³ /t]
$u(t)$	opening of the throttling valve
$K_v(u(t))$	flow coefficient as a function of the valve opening [$\frac{m^3/t}{\sqrt{\text{bar}}}$]
h_v	relative capacity factor for outlet nozzle [$\frac{m/t}{\sqrt{\text{bar}}}$]
$A_v(x(t))$	area of opening between the seat and the needle valve [m ²]
$P_o(t)$	outlet pressure [bar]
\bar{x}	sample mean
x_i	sample number i
n	number of samples
RSD	relative standard deviation
$ \bar{x} $	absolute value of sample mean
σ	standard deviation

1 Introduction

Professor Bernt Aadnøy has developed the autonomous inflow control device (ICD) BECH AFD and the chemical injection valve FloWizard. The valves have the same constant flow principle. They are pressure-independent and consists of two restrictions providing constant flow. The desired flow rate is set at the set point, and the compensation part compensates for changes in pressure at the inlet or outlet of the valve.

ICDs are installed at every connection of the production tubing to overcome premature water and gas breakthrough. The main objective of ICDs is to maintain a uniform inflow by providing an additional pressure loss between the formation and the wellbore.

Chemical injection enhance production and increase recovery. Hydrate formation, deposition of scale, paraffin and asphaltenes is prevented. Chemical injection also minimize corrosion in the production tubing caused by hydrogen sulfide and carbon dioxide. Accurate control of chemical injection is important for production management. Changes in viscosity induced by changes in temperature affect the flow rate in conventional chemical injection control valves, resulting in inaccurate flow. Accurate flow control prevents under- or overdosing of chemicals and thus, reduced operational cost.

Chemical injection valves are subjected to differing temperatures during injection. Processing facilities releases heat from production and the weather affects injection temperature. Historically, ICD have been subjected to reasonably constant temperatures in the reservoir. However, more recently, stimulation treatments have also been combined with ICDs. The reservoir temperature can be altered locally during injection. Injected water is colder than the reservoir and injecting gas can cause increased temperatures. With the increasing use of ICDs for injection, it is important that the devices can achieve constant flow with changes in temperature.

The aim for this thesis is to examine the effect of temperature on the autonomous chemical injection valve FloWizard and compare it with the marked leading product SkoFlo. The results for FloWizard can also be implemented for BECH AFD.

The thesis is divided into a theoretical part and an experimental part. An introduction to valves, fluid properties, inflow control devices and chemical injection devices is presented in the theoretical part. In the experimental part, temperature was changed while measuring the flow through the injection valve. Results were analyzed and suggestions that can improve the experimental methods in further research was purposed.

2 Theory

2.1 Valves

Valves are mechanical devices designed to direct, stop, mix or regulate flow, pressure or temperature of fluids. Valves can be categorized into three areas:

- On-off valves
- Non-return valves
- Throttling valves

On-off valves block the flow or allow it to pass. Non-return valves allow flow to travel in only one direction. Flow or pressure in the opposite direction is mechanically restricted from occurring. Check-valves are non-return valves. Throttling valves regulate flow at any point between fully open and fully closed. [1]

Standard pressure dependent valves have a flow characteristic which describes the relationship between the valve coefficient C_v and the valve stroke. When a valve opens, the flow characteristics will allow a certain amount of flow at a given percentage of the stroke. It allows the valve to control flow in a predictable manner. Flow can be predicted given the following relation: [1]

$$q(t) = C_v \sqrt{\frac{\Delta p(v)}{SG}}$$

$q(t)$ flow rate (gal/min)

C_v flow coefficient of the valve

$\Delta p(v)$ pressure drop across restriction (psi)

SG specific gravity of the fluid

From the equation, it is seen that changes in pressure results in a change of flow rate as the square root of the change in pressure. Continuous set point adjustments are thus required to maintain constant flow if the pressure changes. The restrictor consumes the pressure differential between the inlet and the outlet.

Professor Bernt Aadnøy's inventions FloWizard and BECH AFD are pressure-independent valves, where changes in pressure is countered within the valve. The valves consist of two restrictions providing constant flow. The desired flow rate is set at the set point, and the compensation part compensates for changes in pressure at the inlet or outlet of the valve. Changes in pressure is countered by movement of a spring-loaded piston acting on a needle in a nozzle. The function and use of needles valves is explained in the following:

Needle valves are used to start, stop and regulate flow rate. Thus, needle valves can act as on-off valves or throttling valves.

Needle valves have a long, tapered needle-like point at the end of the valve stem. The needle-like point is often called plunger, and the plunger fits in the seat. Flow is regulated adjusting the position of the plunger. A fine-threaded handwheel must be turned multiple times to retract the plunger, accordingly precise regulation of flow is possible. [2]

Needle valves can be operated manually or automatically. The handwheel is used to control the distance between the plunger and the seat for manually operated valves. To allow fluid to pass through and increase the flow rate, the handwheel is turned to lift the plunger and open the valve. Turning the handwheel in the opposite direction, moves the plunger closer to the seat to decrease the flow rate or close the valve.

Automated needle valves are connected to an air actuator or a hydraulic motor that automatically opens and closes the valve. The actuator or motor adjusts the plunger's position according to timers or data gathered when monitoring the valve.

The valves are ideal in situations where precise adjustment and a small flow rate is required. Needle valves are often used to protect delicate gauges from damage from sudden surges caused by fluid under pressure. [2]

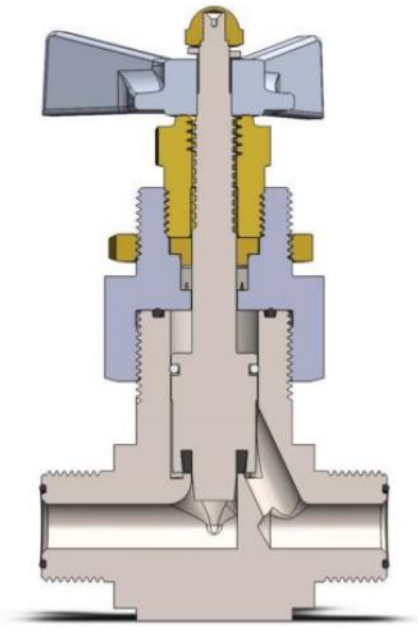

Figure 1. Needle valve [2]

2.2 Fluid properties

2.2.1 Introduction

Understanding of fluid properties is required to understand the cause of pressure loss in fluid flow across restrictions. Three fluid characteristics are of special importance for flow patterns: compressibility, density and viscosity. Compressibility, density and viscosity is a function of pressure and temperature. Thus, the flow rate through valves can be affected by reduced reservoir pressure during production, and changes in temperature during injection. The flow pattern in most ICD is turbulent, and the pressure loss across the valve is thus density controlled. An introduction to valves and some relevant fluid parameters are given in the following.

2.2.2 Laminar and Turbulent Flow

In laminar flow, the flow is characterized by smooth fluid layers and ordered motion. Turbulent flow has irregular velocity fluctuations in all three directions. The transition between laminar and turbulent flow occurs over a region where the flow alternates between laminar and turbulent flow. Most practical flows are turbulent. [3]

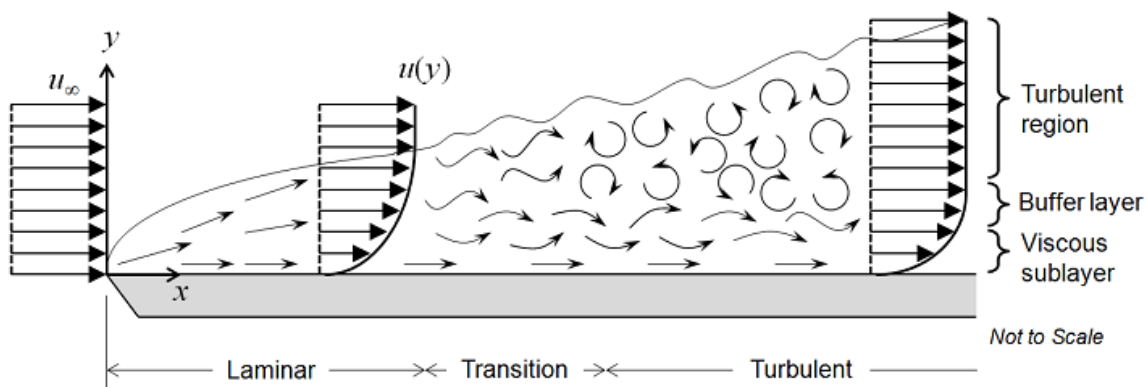

Figure 2. Laminar, transitional and turbulent flow [4]

Reynolds number is evaluated to determine if the flow regime is laminar or turbulent. Reynolds number is a function of density and viscosity which varies with fluid type and temperature. In the 1880s, Osborne Reynolds discovered that the flow regime mainly depended on the ratio of inertial forces to viscous forces. Reynolds number in circular pipes is given by: [3]

$$Re = \frac{V_{avg}D}{\nu} = \frac{\rho V_{avg}D}{\mu}$$

V_{avg} average flow velocity

D characteristic length of the geometry

ν kinematic viscosity

μ fluid viscosity

ρ fluid density

Critical Reynolds number is the Reynolds number where the flow becomes turbulent. The number depends on the geometry and flow condition. For flow in a circular pipe, the critical Reynolds number is 2320. Laminar flow occurs when Reynolds number is lower than 2320 and turbulent flow occurs when Reynolds number is greater than 2320. The pressure drop depends on the viscosity of the fluid for laminar flow. For turbulent flow, the pressure drop depends on the fluid density. [5]

All fluids have viscosity and thus all flow involve viscous effects. In viscous flows, the frictional effects are significant. However, the viscous forces can be negligible compared to pressure or inertial forces in certain flow regions. According to the no-slip condition, the fluid sticks to surfaces and viscous effects become significant in the boundary layer.

Inertial forces dominate in turbulent flows, whereas viscous forces dominate in laminar flow. The inertial forces are proportional to fluid density and the square of fluid velocity, and viscous forces are proportional to the fluid viscosity and fluid velocity. Viscous forces resist movement, thus slowing down the flow. In turbulent flow, the viscous forces are too small to prevent random fluctuations. At small and moderate Reynolds number, the viscous forces suppress the fluctuations resulting in laminar flow. [3]

2.2.3 Fluid properties

Compressibility

Compressibility is a measure of volume change because of changes in pressure.

Compressibility is given by the following equation:

$$\beta = -\frac{1}{V} \frac{\delta V}{\delta P}$$

β compressibility

V volume

P pressure

All fluids are compressible. However, liquids are often assumed incompressible. Depending on the degree of density variation during flow, it is either classified as compressible or incompressible flow. Flow is incompressible if the density remains constant.

The dimensionless Mach number is the relationship between the fluid velocity to the velocity of sound in the fluid. The number indicates whether the fluid flow is compressible or incompressible:

$$Ma = \frac{V}{c}$$

V speed of flow

c speed of sound

The velocity of sound in liquids and gases is a function of pressure and temperature. The presence of gas bubbles or solids reduces the velocity of sound. Gas flows are usually incompressible if the Mach number is less than 0.3. [6]

Density

Density is defined as mass per unit volume, and is a function of pressure and temperature.

Liquids are usually approximated to be incompressible, and variation with pressure is often negligible. However, temperature affects the density of liquids more than pressure. At 20°C, the density of water is changed with 0.5 % from 998 kg/m³ at 1 atm to 1003 kg/m³ at 100 atm. At 1 atm, the density of water changes with 2.3 % from 998 kg/m³ at 20°C to 975 kg/m³ at 75°C. [3]

In the experiments, water was injected while fluid temperature was varied from approximately 15°C to 55°C. The density of liquid water at 1 atm for increasing temperatures is shown in the following table.

Temperature [°C]	Density [kg/m ³]	Temperature [°C]	Density [kg/m ³]
0	999.82	35	994.08
5	1000.00	40	992.25
10	999.77	45	990.22
15	999.19	50	988.02
20	998.29	55	985.65
25	997.13	60	983.13
30	995.71	65	980.45

Table 1. Density of water at different temperatures [7]

Bond breaking in cluster increases density, whereas thermal expansion decreases density. The maximum density for water is at 4°C because the rate of cluster breaking equals the thermal expansion at that temperature. Above 4°C, thermal effects dominate and cause volume expansion and thus decrease in density. The density of water is 1000 kg/m³ at 4°C and the density decreases nonlinearly with temperature.

The density of most gases is proportional to pressure and inversely proportional to temperature according to the ideal-gas equation of state:

$$PV = nRT$$

P absolute pressure

v Volume

R universal gas constant

n number of moles

T absolute temperature

The equation can be expressed with respect to density. Number of moles equals mass divided by molar mass and thus, density is found by dividing mass by volume: [3]

$$\rho = \frac{PM}{RT}$$

M molar mass

The density of liquids can also be affected by the quantity of dissolved gases. However, the effect can generally be neglected. The ability to dissolve gases is pressure and temperature dependent and thus there is also an indirect dependence on these parameters. [6]

Viscosity

Viscosity is the inertial resistance of a fluid to motion, and is a measure of its resistance to deformation when subjected to force. Viscosity is caused by cohesive forces between molecules in liquids and by collisions between molecules in gases. In other words, it is caused by internal frictional forces when different layers of fluids are forced to move relative to each other. Friction forces develops when two fluids layers move relative to each other and the slower layer will slow down the faster layer. [3]

In fluid mechanic and heat transfer, the viscosity is often expressed as the ratio of dynamic viscosity to density. The ratio of dynamic viscosity to density is called kinematic viscosity.

$$v = \frac{\mu}{\rho}$$

Viscosity of a fluid depends on temperature and pressure. The dynamic and kinematic liquid viscosity is almost independent of pressure. Small variations are usually neglected, except at very high pressure. At low to moderate pressures that is also the case for dynamic viscosities of gases. However, kinematic viscosity for gases depends on pressure because the density of a gas is proportional to its pressure. Density increases with pressure and thus the kinematic viscosity will increase. [3]

Viscosity of liquids decreases with temperature while viscosity of gases increases with temperature as seen in figure 3. The molecules in liquids possess more energy at higher temperatures and can thus oppose larger cohesive intermolecular forces. The intermolecular forces are negligible in in gases on the other hand, and the gas molecules moves randomly at higher velocities at higher temperatures. The result is

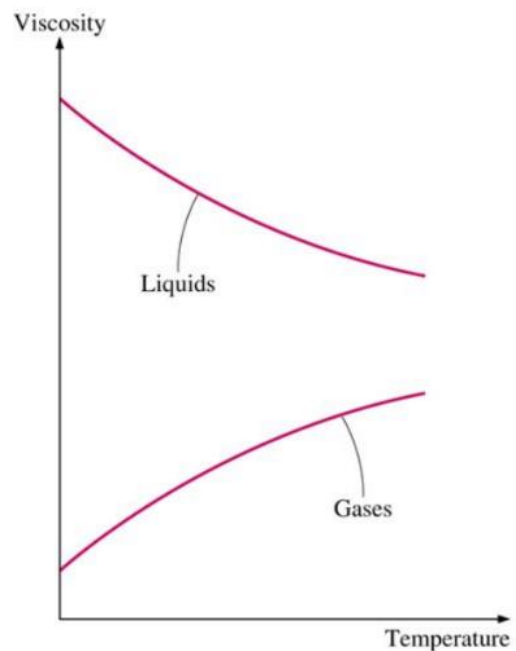

Figure 3. Viscosity as a function of temperature [3]

more molecular collisions per unit volume per unit time and thus greater resistance to flow. [3]

In figure 4, dynamic viscosity and density of water is plotted versus temperature at 1 atm.

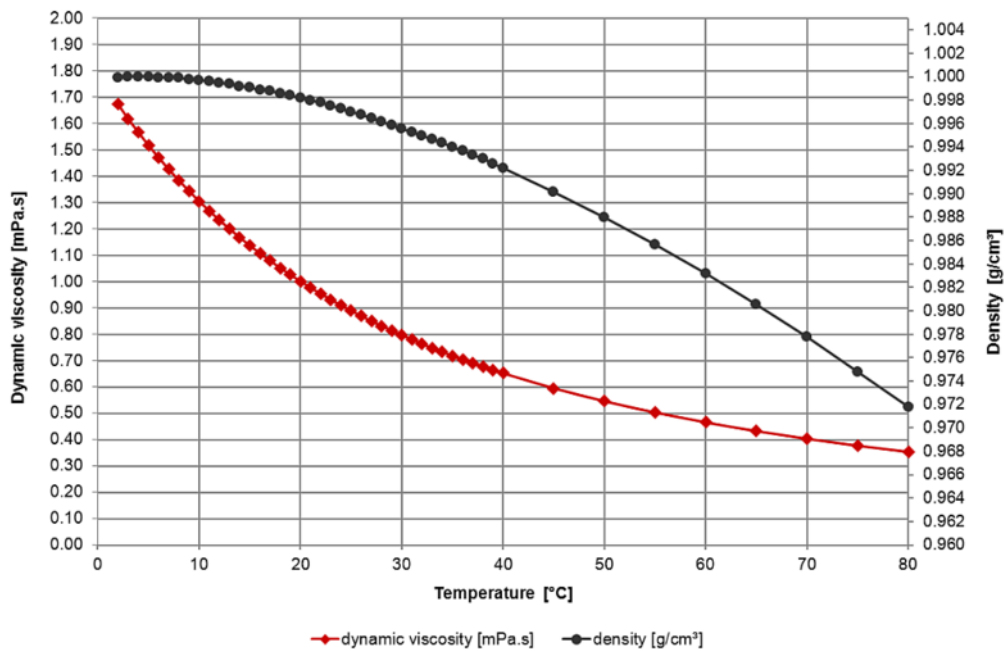

Figure 4. Viscosity and density of water as a function of temperature

A relation for viscosity is obtained by considering a fluid layer between two large plates. A parallel force is applied to the upper plate while the lower plate is held fixed. According to the no-slip condition, the fluid in contact with the upper plate sticks to the plate surface and moves with the same speed. Shear stress causes continuous deformation of the fluid layer. The shear stress acting on the fluid layer will be: [3]

$$\tau = \frac{F}{A}$$

τ shear stress

F force

A contact area between the plate and the fluid

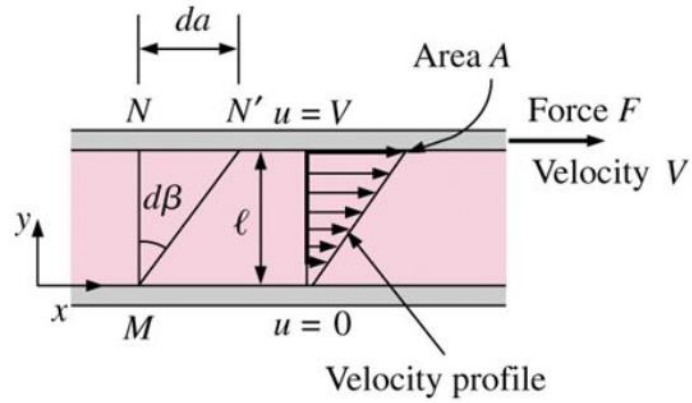

Figure 5. Velocity profile for laminar flow [3]

The velocity of the fluid in contact with is lower plate is zero since the plate is held fixed. The behavior of a fluid in laminar flow between two parallel pipes when the upper plate is moved with a constant velocity and the lower plate is held fixed is seen in figure 5.

The flow varies linearly between the plates and thus, the velocity profile and velocity gradient are given by:

$$u(y) = \frac{y}{l} V$$

$$\frac{du}{dy} = \frac{V}{l}$$

- V velocity of upper plate
- l distance between plates
- y vertical distance from lower plate

During a given time interval dt , the upper plate will move a differential distance while the sides of fluid particles along a vertical line will rotate through a differential angle $d\beta$. The deformation or angular displacement can be expressed as:

$$d\beta \approx \tan d\beta = \frac{da}{l} = \frac{Vdt}{l} = \frac{du}{dy} dt$$

- $d\beta$ differential angle
- dt differential time interval

By rearranging, the rate of deformation caused by shear stress becomes:

$$\frac{d\beta}{dt} = \frac{du}{dy}$$

The conclusion is that the rate of deformation of a fluid element is proportional to the velocity gradient. In addition, experiments have verified that for most fluids the rate of deformation is proportional to the shear stress.

$$\tau \propto \frac{du}{dy}$$

$$\tau \propto \frac{d\beta}{dt}$$

Rheology Models

Fluids where the rate of deformation is linearly proportional to shear stresses are Newtonian fluids. Fluids like water, oil and glycols act as Newtonian fluids, whereas fluids that contain particles larger than molecules are not Newtonian. A plot of shear stress versus rate of deformation is a straight line for Newtonian fluids. The slope is the viscosity of the fluid, and thus viscosity is independent of shear rate for Newtonian fluids.

The relationship between shear stress and rate of deformation is not linear for non-Newtonian fluids. Here the slope is referred to as the apparent viscosity. Bingham plastic fluids requires a certain shear stress before it flows. Pseudoplastic fluids become less viscous as the rate of deformation increases, whereas dilatant fluids become more viscous with increasing rate of deformation. [3]

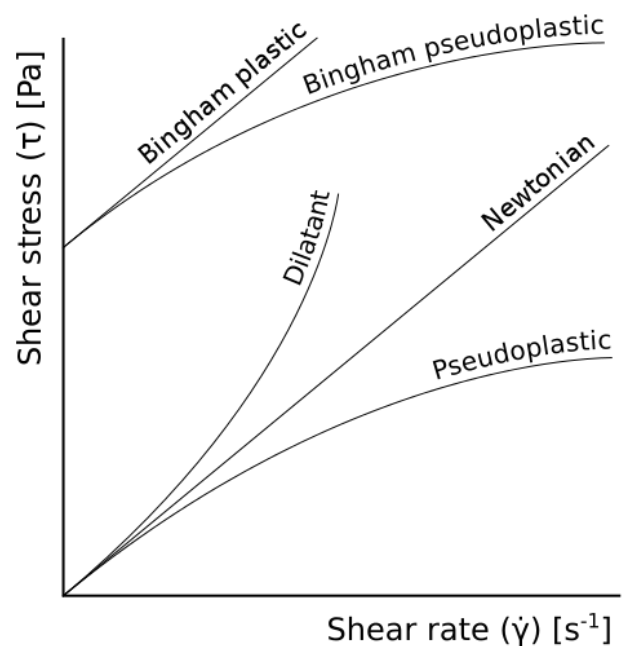

Figure 6. Variation of shear stress with the rate of deformation

2.3 Inflow Control Devices (ICDs)

2.3.1 Introduction

Horizontal and multilateral completions are more prone to water or gas coning due to frictional pressure losses from the toe to the heel of the production tubing and permeability heterogeneity along the well. The frictional pressure drop along the tubing causes higher production of oil at the heel than at the toe. The inflow rate varies along the completion and the inflow imbalance can cause premature coning at the heel. Once water or gas breakthrough, the production of water or gas accelerates. As a result, oil near the toe is not produced and increasing water production creates a disposal issue.

Premature water or gas breakthrough is overcome by installing ICDs at every connection of the production tubing, approximately every 40 ft. The main objective of ICDs is to maintain a uniform inflow by providing an additional pressure loss between the formation and the wellbore. ICDs delay the production of water or gas, and thus increase the reservoir fluid recovery. [5]

2.3.2 Historical Review

When the Troll field was discovered in 1979, it was initially planned as a gas field. However, it has become one of the largest producing oilfields in Norway. The field contains a thin oil column overlain by a large gas cap. The thin oil column has required development of completion technologies. [8]

To recover oil from the thin oil column in the Troll field, horizontal wells were drilled to increase reservoir contact. When the first horizontal wells were drilled, long-term tests were conducted to determine the economical prospective. To reduce the effect of frictional pressure losses along the well, the wells were completed with pre-packed slotted liners. The productivity index (PI) of the first horizontal well was 40 times higher than previous drilled vertical wells. However, it was observed that increased length of horizontal wells did not create proportionately larger production rates. Production logging indicated that 75 % of the contribution to total flow was coming from the first half of the horizontal section. The results were on the contrary to the expected damage near the heel because of longer exposure to drilling fluids. It was discovered that the high inflow near the heel was caused by lower wellbore pressure due to frictional pressure drop between the heel and the toe. [8, 9]

Three completions methods were proposed to increase recovery and to avoid water or gas breakthrough at the heel: a stinger method, reduced perforation density, and ICDs. Perforations are unpredictable regarding penetration and reservoir condition around the penetration, whereas ICDs overcome these uncertainties. After careful reviewing of the alternatives it was concluded that the ICD was the best option. Norsk Hydro first obtained a patent for ICD in 1993. By the end of 2005, 125 wells had been installed with ICD at the Troll field. [8, 10]

The technical principle in the first ICDs was to create a frictional pressure drop by forcing the fluid through a helical channel. The level of choking was changed by adjusting the length of the flow channel. There are now several ICD designs that create a pressure drop including

orifices, nozzles, helical and hydrides. The pressure loss is created as a combination of friction and/or restriction of inlet area. [11, 12]

There has been a continuous development of the technology and an increasing range of application. Initially ICDs were developed to delay water or gas coning at the heel by creating an additional pressure drop at the heel. In heterogenous reservoirs, water or gas will breakthrough at the high-permeability regions. In these cases, ICDs can also be installed. ICD completions have become a common technology in horizontal wells.

ICDs are not an optimal solution when the inflow conditions change as the well matures since they are not adjustable or retrievable. The industries efforts to solve the problem, has resulted in the relatively recent technological breakthrough of AICDs who restrict inflow of unwanted fluids after breakthrough by creating a higher pressure differential. The use of autonomous inflow control devices (AICDs) is increasing. There are several available designs including rate controlled production (RCP) valve, fluidic diode (FD) and hybrid autonomous ICDs. The first RCP production valve was installed at Troll in 2008. The evaluation of the first wells at Troll completed with AICDs concluded that cumulative oil production is approximately 20 % higher with AICD than ICD. From the end of 2012 almost every well on Troll has been completed with AICD. Autonomous inflow control valves (AICVs), a further development, autonomously stop the production of unwanted fluids. [13-15]

2.3.3 Advantages

ICDs increase the recoverable reserves. High producing zones are restricted thus stimulating low producing zones. The result is:

- Equalized flux along the wellbore delaying water or gas breakthrough.
- Reduced annular flow and thus risk of sand production behind the screen resulting in plugging and erosion.
- Improved well clean-up and reduce the effect of drilling formation damage.
- Controlled outflow in injection wells. [10]

Homogenous reservoirs

In homogenous reservoir the heel-to-toe effect will be dominant as seen in figure 7. The frictional pressure loss increases with the length of the well, and higher inflow rates from the heel than at the toe is caused by the frictional pressure losses. ICDs delay breakthrough by creating an additional pressure drop in the heel region and by creating a uniform production profile along the entire length of the wellbore. To achieve ultimate recovery, the water front or gas front must enter the tubing over the entire length. [5]

Heterogenous reservoirs

Long extended horizontal wells will most likely encounter heterogeneous reservoirs. Carbonate reservoirs tend to have a high degree of fracturing and permeability heterogeneity. Early water or gas breakthrough anywhere along the length of the wellbore can result from reservoir heterogeneity or from different distances between the wellbore and the fluid contacts. High permeability zones produce at a higher rate than low permeability zones, and high permeability zones are more dominant than the heel-to-toe

effect. ICDs chokes the flow rate at high-permeability zones, thus delaying water or gas breakthrough as seen in figure 10. [16]

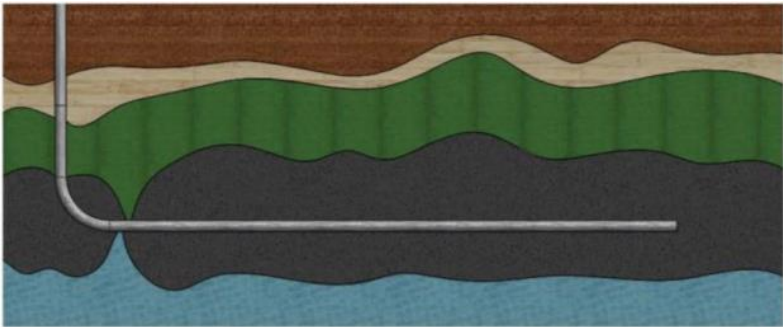

Figure 7. Water and gas breakthrough in homogenous reservoir [14]

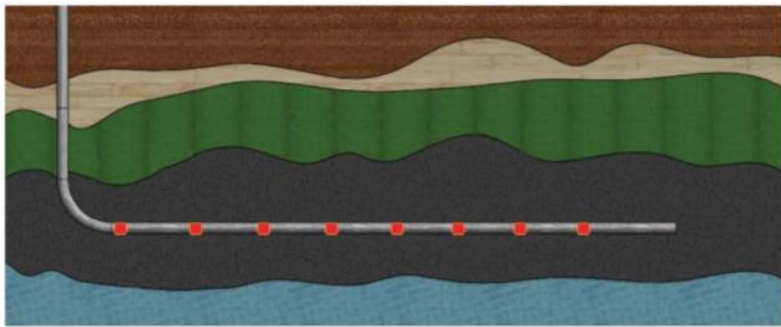

Figure 8. Uniform inflow profile after installation of ICD in homogenous reservoir [14]

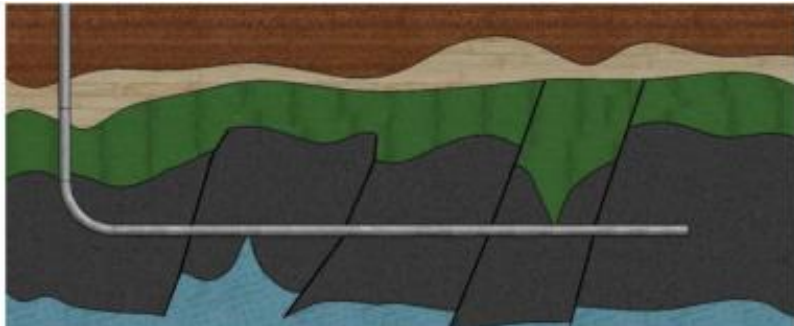

Figure 9. Breakthrough of water and gas in heterogenous reservoir [14]

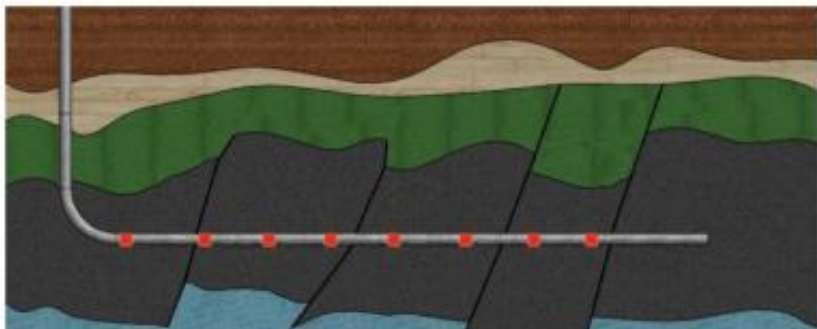

Figure 10. Uniform inflow profile after installation of ICD in heterogenous reservoir [14]

Clean-up

Clean-up of the filter cake can be a challenge in high-permeability horizontal wells. High permeability zones at the heel will preferentially clean-up due to high initial drawdowns. The areas away from the heel have the disadvantage of frictional pressure drops and low velocities to remove the filter cake. Poor filter cake clean-up will result in irregular flow contribution, higher coning potential and lower productivity. ICDs can create a sufficient pressure drop at the toe for the reservoir fluid to lift off the filter cake and flow other solids to the surface. Thus, extended well lengths are allowed without compromising the clean-up efficiency in the lower sections of the well. [17]

Injection

During injection in a reservoir with heterogeneous permeability, most of the fluid is injected in the high permeable sections causing poor recovery from the lower permeability sections. Installing ICDs results in an even injection profile. It will improve the ultimate sweep efficiency. [18]

2.3.4 ICD Types

ICDs can be divided into passive inflow devices (PICD) and AICDs according to whether their flow resistance ratings (FRR) are constant. PICDs maintain uniform flow across production zones by generating an additional pressure drop. Their FRRs are fixed and after water or gas breakthrough occurs, the low viscosity water or gas will take over the well. AICDs, on the other hand, will generate a greater flow resistance once breakthrough occurs, thus limiting water or gas production. [19]

2.3.4.1 PICD

The pressure drop in PICD can be created by restriction, friction or by cooperating both mechanisms. The most common PICDs, the nozzle-based and the orifice type, use restriction to create a pressure drop. Labyrinths and helical channel-based devices use the friction mechanism. Hybrid and tube designs use a combination. Some available designs are: [19]

The channel type uses surface friction to generate a pressure drop. The produced fluid flows through a multiple-layered screen into an annulus between the screen and a base pipe. The fluid is then forced through helical channels with pre-set diameter and length. The flow velocity is lowered due to changes in flow direction numerous times, which reduces the chance of erosion and plugging. A disadvantage of the channel type is that the pressure drop is viscosity dependent. Because the frictional pressure loss is a function of the viscosity, the level of choking is reduced after water or gas breakthrough. [20]

The orifice type uses fluid restriction to generate a pressure drop. The orifices are inserted in a jacket around the base pipe. The fluid is forced through several preconfigured orifices into the pipe to create a flow resistance. The pressure drop is a function of the fluid density and velocity and independent of the viscosity. [16]

The nozzle is similar to the orifice type and fluid restriction is also to generate a pressure drop. The restricting ports are inserted into the base pipe or into the housing outside the base pipe. The pressure drop is a function of the flow rate. According to Bernoulli's equation, the pressure drop through a port increases with the square of the fluid velocity. [16]

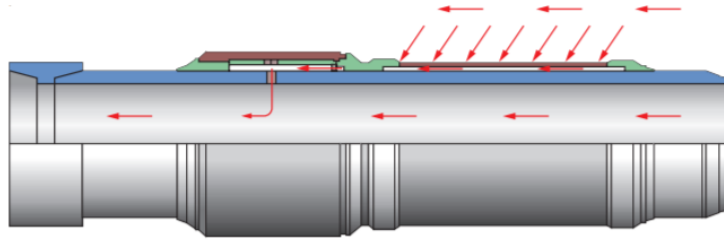

Figure 11. Nozzle-type ICD [16]

2.3.4.2 AICD

AICDs provide a uniform inflow profile along the horizontal section. In addition, they have a self-regulating adjustable design that provides greater choking where breakthrough occurs. AICDs combine passive inflow control with an active inflow control. The active element ensures that the pressure differential across the AICD also depends on the composition and properties of the fluid. When fluid properties change, the device reacts autonomously by changing the geometry of the fluid's flow path or by altering the flow path as a function of the controlling properties. Some available designs are: [13]

When gas or water flows through the RCP valve, the high fluid velocity will cause lower pressure at the flowing side of the disk. The total force acting on the disc will move the disc towards the inlet causing reduced flow area and thus flow. When more viscous fluids flow through the RCP, lower force acts on the disc towards the inlet. The disc will move away from the inlet causing increased flow area and flow. [15]

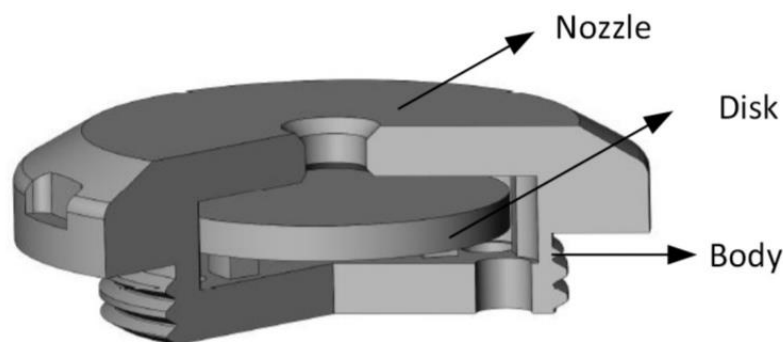

Figure 12. PCP valve construction [15]

FDs utilizes differences in inertia. In oils viscous forces in the oil are larger than the inertial forces, and in water and gas the inertial forces dominate. Fluids where the inertial forces dominate will take a straight pathway through the device and a brief period of higher velocity creates a backpressure that restricts passage of fluids through the AICD. [21]

For BECH autonomous flow controller device (AFD), the technology includes a valve and a valve body inserted into the completion equipment in the direction required for production or injection. The flow rate for each regulator is set prior to installation and can be modified as desired onsite. The regulation is based on a hydraulic feedback principle with control provided by Bernoulli's principle. [18]

2.3.5 Limitations of ICDs

The flow rate through ICDs depends on the pressure drop. The flow through ICDs will thus change when the reservoir pressure declines during production and may cause coning. It is explained in the following.

The fluid flows from the reservoir, through the ICDs and the production tubing. The fluid flow in horizontal wells are controlled by three different pressure differentials:

- (1) Reservoir drawdown which is the pressure differential between the reservoir pressure and the flowing bottomhole pressure controls the flow capacity of the well. Rock permeability, fluid viscosity and exposed rock area also affects the flow rate. The flow is usually laminar (viscosity dependent) from the reservoir. Radial steady-state inflow from the reservoir is given by Darcy's law:

$$\Delta P = \frac{Q\mu B}{2\pi kh} \ln\left(\frac{r_e}{r_w}\right)$$

ΔP	reservoir drawdown
B	formation volume factor
k	reservoir permeability
r_e	radius of drainage
r_w	wellbore radius

- (2) Pressure drop across ICD is usually turbulent (density dependent) and non-linear.
- (3) Pressure drop along the tubing results in coning at the heel of the well. The flow is turbulent and/or laminar through the production tubing. High capacity wells in Norway has laminar (viscosity dependent) flow at the toe. The flow becomes turbulent (density dependent) towards the heel as the cumulative flow increases. The degree of turbulence decreases with depletion. Flow rate versus pressure drop is non-linear and varies with reservoir depletion. [22]

Flow in a conduit can be expressed in simple terms with respect to pressure drop:

Laminar flow: $\Delta P \sim \mu Q$

Turbulent flow: $\Delta P \sim \rho Q^2$

The pressure drop versus flow rate is complex and highly non-linear. The density is relative constant throughout the lifetime of the well, while the viscosity can vary significantly. Flow through the ICD will thus change when the reservoir pressure declines. It is not possible not maintain constant flow because of the non-linear nature of the flow system, and because of the decreasing degree of turbulence with depletion.

The limitation for ICDs are demonstrated for the commercial ICD FloReg™ seen in figure 13. where flow rate is plotted versus pressure drop. FloReg™ has 10 nozzles where the flow can be varied by plugging one or more nozzles. The flow characteristic is non-linear.

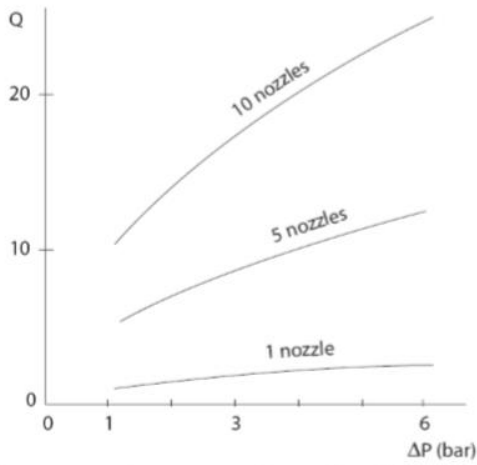

Figure 13. FloReg™ [22]

2.3.6 BECH AFD (autonomous inflow device)

Professor Bernt Aadnøy has patented a method of incorporating an autonomous flow control valve in the downstream location of the chokes. The flow controlled Ryger valve was invented in 2009 after observing the drawbacks of pressure controlled ICDs. The design was bought by the company BECH who now has the legal rights for the product now called BECH AFD.

The valve provides advantages when pressure in the reservoir changes due to injection or depletion. BECH AFD offers constant flow regardless of pressure. Thus, the flowrate remains constant during injection or depletion. The valve can also be calibrated for increasing flow or decreasing flow is desired.

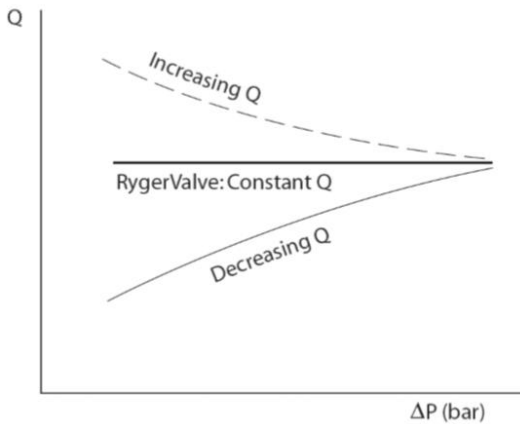

Figure 14. Flow rate as a function of pressure drop for BECH AFD [22]

The valve consists of two main parts:

- Set point
- Compensation part

At the flow set point a screw, a needle or nozzles are plugged to achieve the desired flow rate. The pressure loss through the set point restriction causes lower pressure when the flow goes into a chamber. In the chamber, a spring membrane or piston is connected to a needle. It is the compensation part. Changes in reservoir pressure or pressure inside the tubing is compensated by piston movement creating constant flow through the nozzle. A prototype of the valve is shown in figure 15.

The valve can be designed with a spring loaded piston acting on a needle in a nozzle, or as a membrane. If designed with a membrane, the membrane must have a spring constant mimicking the function of the piston version. [22]

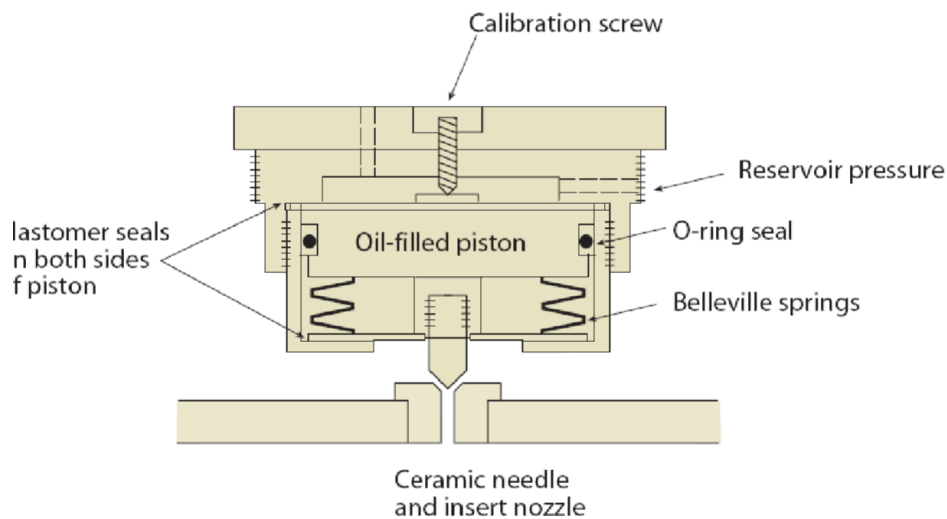

Figure 15. Prototype of BECH AFD [22]

The physics of the valve is explained in the following.

The pressure is reduced from the reservoir to the chamber when the fluid flows through the flow setting nozzle. A force balance across the piston gives:

$$P_{res}A - P_2A - Kx = 0$$

Force balance between the chamber and the production tubing gives:

$$P_2 - P_{tub} = K_v \rho Q^2$$

Solving the first equation with respect to P_2 and inserting into the second equation, the equation for constant flow rate is obtained.

$$P_{res} - P_{tub} = \frac{Kx}{A} + K_v \rho Q^2$$

$$Q = \sqrt{\frac{1}{K_v \rho} ((P_{res} - P_{tub}) \frac{Kx}{A})}$$

P_{res} reservoir pressure on the outside of the system

P_2 pressure in chamber after flow setting

P_{tub} production tubing pressure

A area of piston

x displacement of spring loaded piston

K spring constant

K_v nozzle constant

The constant flow valve is not sensitive to viscosity. However, it is sensitive to density. During production of liquid, the change in density is negligible. The spring force is calibrated to account for changes in differential pressure. The expression under the root sign will thus be approximately constant, giving a constant flow rate. [22]

2.3.7 A Hydraulic Model for the ICD

An orifice ICD tool is shown in figure 16. Screens are twisted over base pipe. Axial rods provide standoff from the base pipe and provide conduits for flow towards the ICD. The fluid flows from the reservoir and through the screens into a pathway along the base pipe. Then, the fluid flows through a chamber before flowing through a number of orifices. These orifices control the flow. Finally, the fluid flows through several holes in the casing. [5]

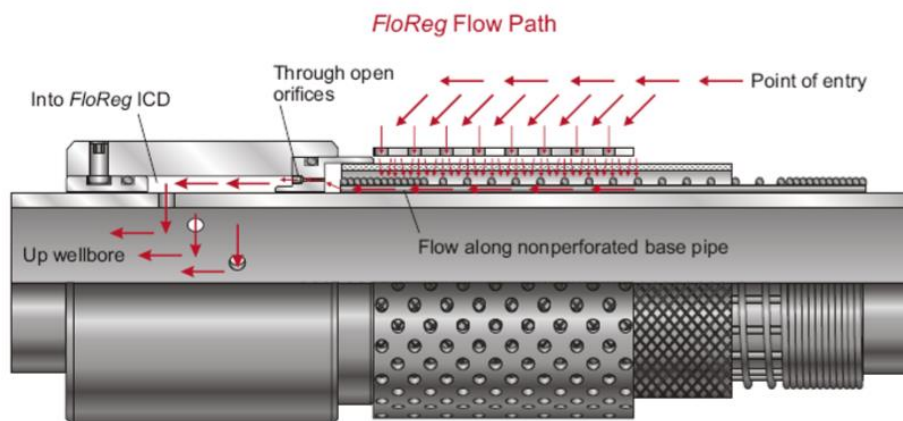

Figure 16. Typical ICD device [5]

The flow model includes pressure drop from the reservoir, through the ICD and into the base pipe. The flow path is coupled in series and the pressure loss is divided into the given components:

- The outside screen
- The conduit below the screen

- The chamber
- The orifices
- The holes through the casing [5]

The flow outside the screen and the conduit below the screen is modelled as laminar flow. The pressure drop through the chamber can be neglected since the velocity is relatively small. Fully turbulent flow is assumed through the restricting nozzles.

Outside the screen, the pressure drop is modelled as laminar flow between two plates as given by:

$$\Delta P = \frac{12\mu QL}{wh^3} = \frac{12\mu QL}{Ah^2}$$

wh effective flow area

Q flow rate

L length of screen

The axial conduit flow below the screen is more complex. The flow at any point is the cumulative flow from the screen openings upstream. As a result, the flow increases from one end to the other. The rectangular shape of the flow in another complexity. The laminar pressure drop for a circular pipe is given by:

$$\Delta P = \frac{32\mu v}{d^2} L = \frac{32\mu Q}{d^2 A} L$$

d hydraulic diameter

Pressure drop upstream from the nozzle is negligible. Assuming turbulent flow through the nozzles initially, pressure loss through the nozzles are given by the following equation:

$$\Delta P = \frac{1}{2} \rho v^2 = \frac{\rho Q^2}{2A^2} = \frac{\rho Q^2}{2\pi^2 r^4}$$

Q flow rate

A effective inflow area

r nozzle radius

The total pressure loss will be given by the sum of the pressure losses across the screen, the conduit below the screen and the nozzles:

$$\Delta P = \frac{12\mu QL}{Ah^2} + \frac{32\mu Q}{d^2 A} L + \frac{\rho Q^2}{2\pi^2 r^4 n}$$

n number of nozzles

L length of screen

A system containing a restriction is controlled by the restriction. Most of the pressure drop occurs across the restriction. Since the flow through the restriction is turbulent, the flow through the ICD is density controlled. [5]

2.3.8 ICD and Temperature

The temperature during production is relatively constant. Fluid from the reservoir is transported through ICDs during production. The inflow control device is thus calibrated to the reservoir temperature. However, more recently, stimulation treatments have been combined with ICDs. The reservoir temperature can be altered locally during injection. When water is injected to increase the reservoir pressure, the fluid flowing through the valves are colder than the reservoir. When injecting gas, the gas is compressed which causes increased temperatures. The temperature might get higher than the temperature in the reservoir. During water alternating gas (WAG) where water injection and gas injection are carried out alternately for a period, the valves also experiences alternating temperatures. The injection temperature depends on the flow rate. The larger injection rate, the larger potential for temperature difference. With the increasing use of ICDs for injection, it is important that the devices can achieve constant flow despite changes in pressure and temperature.

2.4 Chemical Injection Systems

2.4.1 Introduction

The development of challenging oil and gas fields has created an increased demand for chemical injection. The new challenges are related to well and water depth, high temperature and pressure, salt content and other contaminants. Chemical injection enhance production and increase recovery. Some of the purposes of chemical injection is to enhance flow characteristics and quality of oil and gas before transportation, prevent hydrate formation, and prevent deposition of scale, paraffin and asphaltenes. There are also other advantages with chemical injection systems. They minimize corrosion in the production tubing caused by hydrogen sulfide and carbon dioxide. In addition, chemicals can remove deposits of salt, wax or other minerals that can build up and decrease production. It results increased production times between required well interventions. Chemicals in use include wax and corrosion inhibitors, methanol, demulsifiers, dilutants, biocides, and water treatment chemicals. [23]

Accurate control of chemical injection is important for production management. Changes in viscosity induced by changes in temperature affect the flow rate in conventional chemical injection control valves, resulting in inaccurate flow. Accurate flow control prevents under- or overdosing of chemicals and thus, reduced operational cost. Overdosing of chemicals may also harm the environment if the chemicals follow produced water to the sea.

2.4.2 Chemical Injection Systems

There are several techniques used to apply chemical injection including topside chemical injection and downhole chemical injection. It may also be installed in deep-water or other harsh environments. Several components make up chemical injection systems. The required equipment for chemical injection can vary depending on application, usage and environment. Dosing pumps meter out chemicals via manual, electric, or pneumatic mechanisms, whereas flow control valve panels allow more than one chemical to be injected into multiple adjustable points. [23]

The conventional approach for chemical injection is to use a separate chemical injection pump for each injection point. These systems are small and inexpensive for topside injections at low to moderate injections. However, in deep water and high-pressure applications injection pumps can be expensive, large and heavy. A common alternative is to use injection rate control valves (IRCV) for these applications. [24]

2.4.2.1 Downhole Chemical Injection

A downhole injection system located offshore typically consists of a surface injection pump at the production platform, a chemical injection line to carry the chemicals and a flow control valve. The chemicals are injected through a capillary injection line that has $\frac{1}{4}$ " or $\frac{3}{8}$ " outer diameter. The capillary injection line comprises of at least two segments: (1) The injection umbilical which connects the platform to the subsea flow control system, and (2) the injection tubing which runs in the annulus between the production tubing and the casing all the way down to the delivery point, the chemical injection mandrel. The mandrel is typically placed upstream of the downhole safety valve or deeper in the well. The chemical injection valve is a check valve which controls the chemical injection pressure into the wellbore and prevents wellbore fluids from flowing into the capillary injection line. [25, 26]

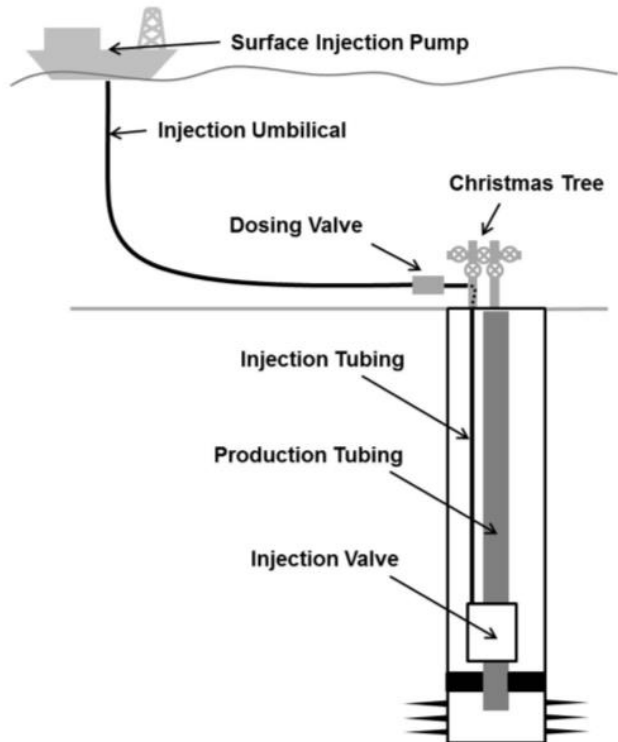

Figure 17. Downhole Chemical Injection Valve for Offshore well [25]

Two main strategies are applied to control the fluid flow rate: (1) Subsea, the injection pump is providing sufficient pressure for the dosing valve which controls the flow rate, and (2) at the platform, the injection pump itself or the injection pump coupled to a flow distribution manifold is controlling the flow rate. [25]

2.4.3 Chemical Injection Properties

Chemical Injection System Properties

The required design parameters for injection systems can be divided into two groups: Geometric and flowing characteristics. The geometric characteristics include length, inclination and inner diameter of the segments of the chemical injection line. These properties are mainly constant during the lifetime of the system. The flowing characteristics are fluid flow rate, temperature profile and pressure at the delivery point. These properties will change according to the production profile. [25]

Chemical Injection Fluid Characteristics

The fluid properties required for designing downhole chemical injection systems are density, viscosity and compressibility. Since the fluid is a liquid under operational conditions, the density dependence on temperature and pressure can be neglected without causing considerable design errors. The exception is for highly compressible liquids. However, fluid viscosity is dependent on pressure and temperature. It is important to identify the various temperatures the system will be subjected to and the relating viscosity ratings. Viscosity

affects flow rate, pressure and wear. The fluid compressibility can also be considered constant because of its small dependency on pressure and temperature. [25]

The operating temperature of chemical injection valves can be affected by the processing facilities and the weather. During drilling and production, heat is transported to the platform. It is cooled down in the process facilities, and heat is released from the facilities.

2.4.4 Chemical Distribution System

IRCV are self-regulating and pressure-independent valves that can be adjusted remotely or locally for optimized control. IRCVs are used for “multilocation injection”, where the requirement for positive displacement pumps is reduced to only one pump per chemical and control of the injection rate is achieved by fitting a valve at each point of injection. Thus, the injection rate is not affected by the length of the injection line. The backpressure in the wells at the points of injection differs. In a conventional valve, the flow rate depends on the differential pressure and the valve opening. A chemical distribution system generally consists of IRCVs, isolation valves, check valves, and a flow meter. A typical chemical distribution system for downhole chemical injection is shown in Figure 18. [24]

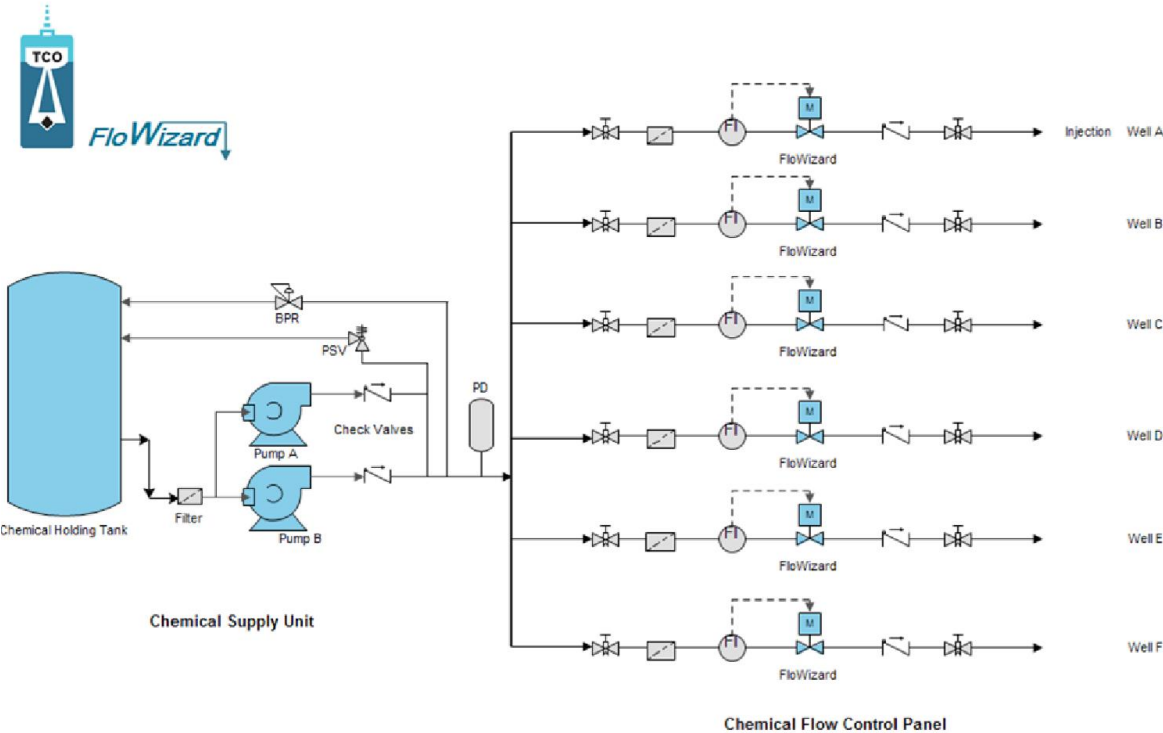

Figure 18. Chemical distribution system [27]

The chemicals are stored in a tank and then the chemicals are distributed with a circulation pump through a filter where particles are removed. Excess chemicals are sent back in a separate pipe to the storage tank. Pulsation dampeners are installed at the outlet of the injection pumps to reduce pulsation from the pumps. The contamination of chemicals is controlled further by sending the chemicals through the injection filter before reaching the dosing cabinet where a manifold for distribution of chemicals to each point of injection is

installed. The flow rate is regulated by a pressure independent valve at each point of injection. [27]

2.4.5 Injection rate control valves

IRCV is available for topside and downhole operation. There are two main suppliers of topside IRCVs in the oil industry today: (1) Haskel valve which is a needle valve type, and (2) SkoFlo valves which are a fixed orifice type valve. However, several companies provide subsea valves including SkoFlo, Oceaneering and Cameron. Professor Bernt Aadnøy's invention FloWizard is about to be commercialized by the company TCO.

There are two types of IRCVs. Haskel and SkoFlo regulates flow using pistons, spring systems and orifices. The other type uses closed loop flow control. Cameron and National Couplings uses a closed loop flow control system with integral flow meters and throttling valves. [28]

IRCVs has smaller space requirements and less weight compared to conventional systems requiring separate pumps for each injection point. Other benefits include:

- Lower installation cost
- Less maintenance
- Control at point of injection

2.4.5.1 Haskel valve

Chemicals enters the inlet at pressure P_{in} . The pressure drops through the regulator valve resulting in a pressure P_1 below the piston. Across the needle valve, the pressure drops to P_2 . Pressure P_2 is ported to the IRCV above the piston. The IRCV controls flow by maintaining a constant pressure drop across the needle valve. The pressure drop across the needle valve is balanced by the bias string. If the inlet pressure or the outlet pressure varies, the piston will move to try to achieve a constant pressure differential $P_2 - P_1$ across the needle valve. The position of the needle is adjusted to calibrate the flow. [24]

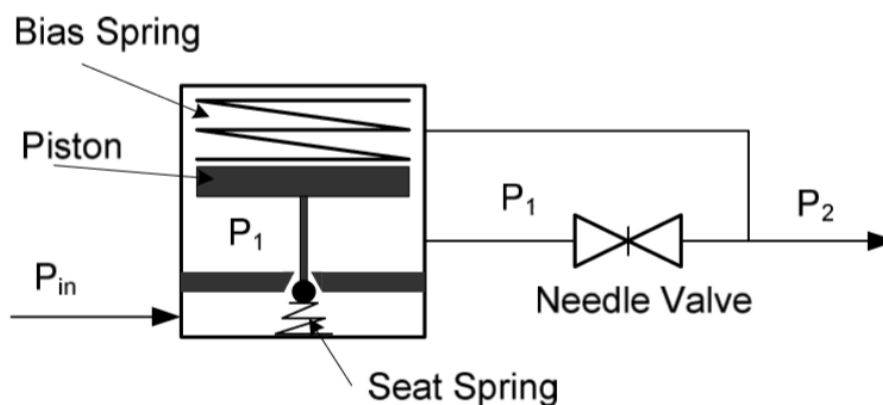

Figure 19. Haskel valve [24]

2.4.5.2 SkoFlo valve

SkoFlo Industries designs and manufactures pressure-independent chemical injection metering valves for surface and subsea use in the oil and gas industry. The pressure-independent SkoFlo valve maintains a constant flow with changes in pressure drop. [29]

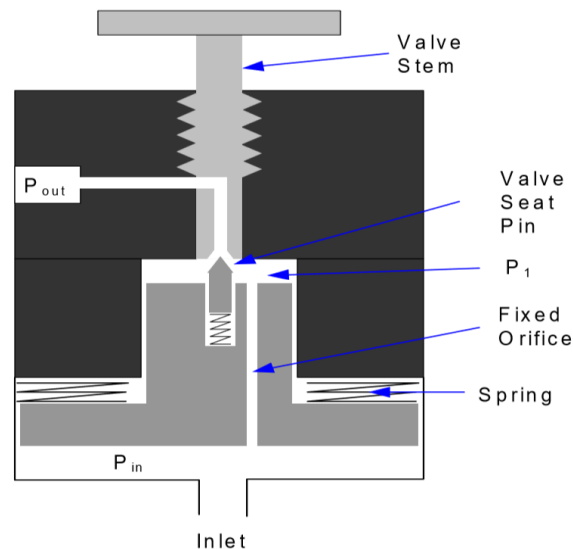

Figure 20. SkoFlo [24]

Flow enters at pressure P_{in} below the piston. A fixed orifice is inserted into a drilled hole in the piston. The chemicals flow through the fixed piston, and the pressure drops to P_1 above the piston. IRCV attempts to control flow by maintaining a fixed pressure drop across the fixed orifice. Then, the pressure is dropped further to P_2 through the regulator seat at the outlet. The regulator valve consists of a valve seat machined into the valve stem and a ceramic seat pin mounted into the piston. Flowrate calibration can be achieved by rotating the valve stem to adjust the position of the internal valve seat. [24]

The pressure drop produces a net force on the piston which is countered by the spring force. The spring force is kept equal to the pressure differential by a ceramic throttling point attached to the piston and thus maintaining a constant flow independent of external pressure fluctuations.

When the pressure drop across the valve increases, flow through the valve will momentarily increase resulting in increased pressure drop across the restriction and the piston. The increased pressure drop causes the piston to move the pin toward the seat restricting flow. The change in spring force will be negligible and the pressure balance across the piston will be the same after the piston reacts to the pressure change. [29]

2.4.5.3 FloWizard

FloWizard is a needle type and principle behind FloWizard to direct flow through two restrictions in series. The first restriction is an external regulator valve. The desired flow rate is set at first restriction. The second restriction is a needle in a nozzle. The needle in the nozzle is connected to a spring-loaded piston. The flow rate can be calibrated by changing the position of the needle.

The flow enters at pressure P_1 . Pressure loss across the needle valve V_2 results in pressure P_2 below the valve. The fluid above the piston acts on the piston surface with pressure P_1 from above and compresses the spring. The pressure P_2 acts on the piston surface from below and is less than the inlet pressure P_1 . The needle in the nozzle creates the restriction V_3 . P_0 is the backpressure, pressure at the point of injection.

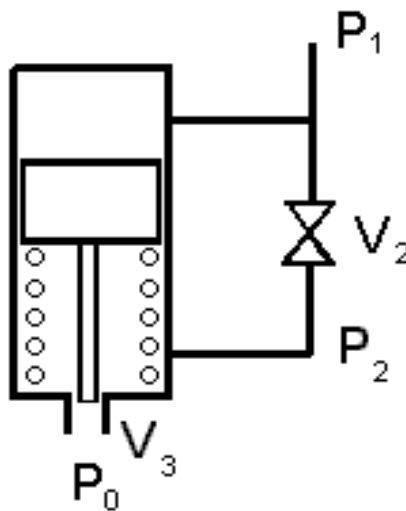

Figure 21. FloWizard

The differential pressure across the first restriction is constant and controls the flow. The second restriction is adjusted by the spring force which determines the position of the piston causing constant flow through the nozzle. Changes in reservoir pressure or pressure inside the tubing is thus compensated by the piston movement. The liquid flowing through the valve is assumed to be incompressible. Thus, the flow is equal through the two regulating valves. [27]

If the outlet pressure increases, the internal pressure P_2 also increases. The piston is pushed upwards, and the spring force is reduced. The reduced spring force results in opening of the needle valve. Thus, the internal pressure is reduced. The forces are eventually stabilized resulting in a constant pressure differential regardless of the changed outlet pressure. The constant pressure differential across the external valve is mainly caused by the spring force that connects the inlet pressure, the outlet pressure and the opening of the needle valve.

2.4.5.4 Derivation of flow across valve

The physics of FloWizard is derived for the design with an external regulating valve as shown in figure 22.

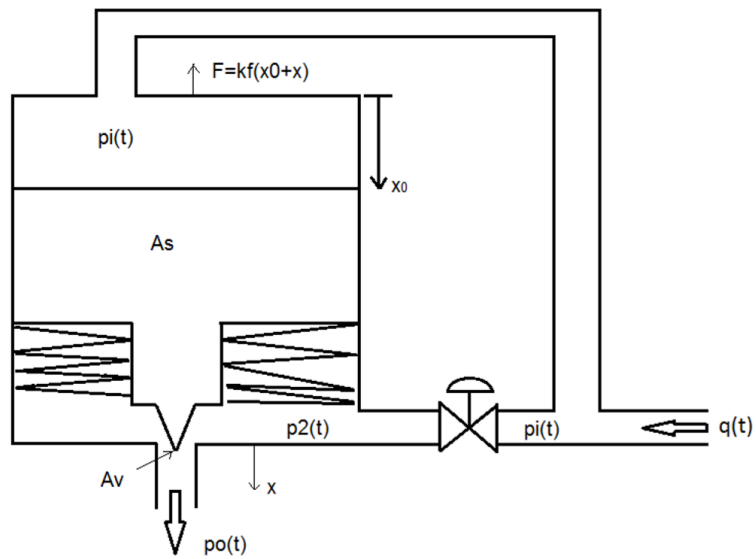

Figure 22. FloWizard [27]

Based on the figure, three equations can be derived to describe flow, pressure and position of the needle valve.

Force balance between inlet pressure, internal pressure and spring force results in:

$$K_f(x_0 + x(t)) = A_s(P_i(t) - P_2(t))$$

- K_f spring constant [N/m]
- x_0 preposition of spring [m]
- $x(t)$ compression of spring [m]
- A_s piston surface area [m²]
- $P_i(t)$ inlet pressure [bar]
- $P_2(t)$ internal pressure [bar]

The flow through the first regulating valve is given by:

$$q(t) = K_v(u(t)) \sqrt{(P_i(t) - P_2(t))}$$

- $q(t)$ flow [m³/t]
- $u(t)$ opening of the throttling valve []
- $K_v(u(t))$ flow coefficient as a function of the valve opening [$\frac{m^3/t}{\sqrt{\text{bar}}}$]

The flow through the internal needle valve that is connected to the piston is given by:

$$q(t) = h_v A_v(x(t)) \sqrt{(P_2(t) - P_o(t))}$$

h_v relative capacity factor for outlet nozzle $\left[\frac{m/t}{\sqrt{\text{bar}}}\right]$

$A_v(x(t))$ area of opening between the seat and the needle valve [m^2]

$P_o(t)$ outlet pressure [bar]

2.4.5.5 Pressure Independent Valve

The aim of FloWizard is to provide constant flow independent of pressure fluctuations. The ability of FloWizard to provide constant flow when pressure is varied has been verified by experiments. Tests were performed on a prototype of the valve built by Professor Bernt Aadnøy, Teamtrade AS and Prekubator, and the flow characteristics of the prototype was compared with two of the marked leading products, SkoFlo and Amflow. FloWizard proved to be more accurate than SkoFlo and Amflow. FloWizard showed the lowest error, even at flow ranges that was 100 times larger than for AmFlow and SkoFlo. [30]

In 2010, experiments were performed where the pressure was varied from 20 bar to 130 bar which probably is beyond the pressure variations expected when used in the oil and gas industry. Flow was set at 75 bar and the nozzle opening was three turns on the needle. The results are shown in figure 23.

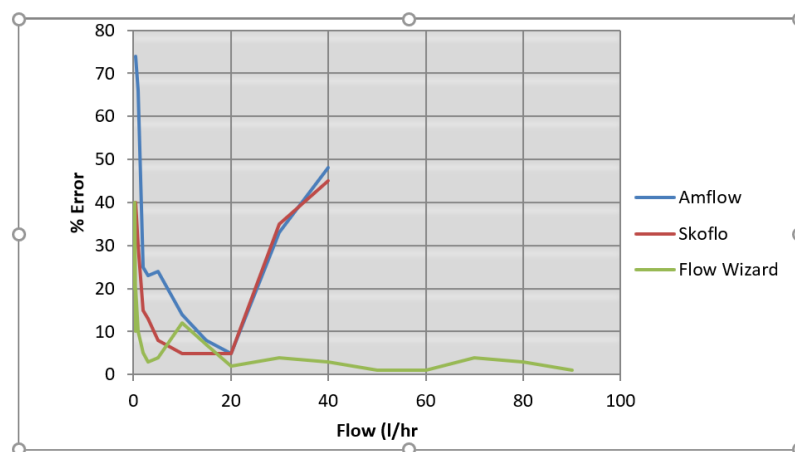

Figure 23. Variations in flow [%] over pressure range 20 - 130 bar [30]

In 2011, variations in flow were tested for the pressure interval 20 bar and 80 bar. Flow was set at 20 bar and the nozzle opening was two turns on the needle. The results from a common flow region for chemical injection is shown in the following figure.

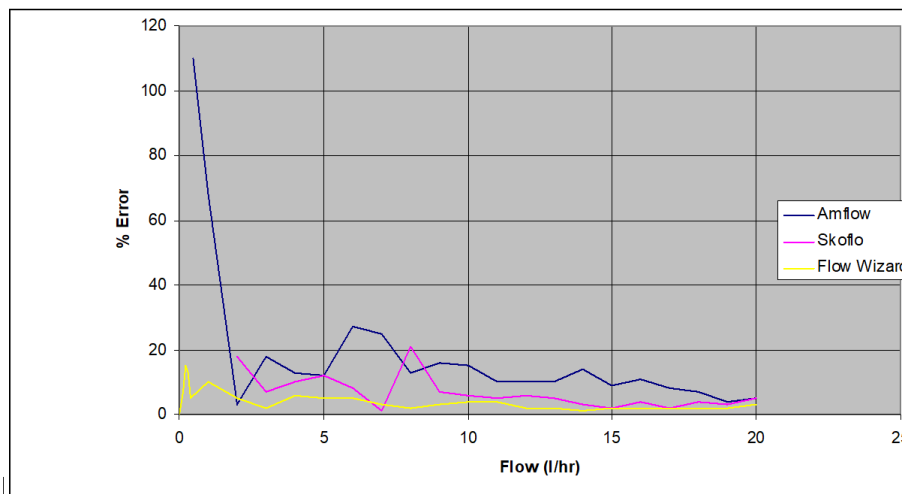

Figure 24. Variations in flow [%] in common flow region [30]

Historical background of FloWizard

Professor Bernt Aadnøy at the University of Stavanger got an idea for a new injection valve in 2001. Three national patents have been approved since 2002. The patents involve the regulation principle, remote operation of the valve and that chemicals are not in contact with the regulation mechanism.

The motivation behind the project has been the challenges with chemical injection valves available in the industry today. Frequent maintenance is required, and the accuracy is adequate only in a restricted flow range. Thus, the valve must be replaced when flow outside the range is required. The valves are also difficult to adjust which creates challenges for automation and remote operation. [27, 31]

Teamtrade AS started the commercialization of FloWizard before the company TCO continued the work after signing an agreement for technology rights to the patented topside flow control valve. The investment is a result of the company's desire to enter the topside market for chemical injection. Most of the commercialization has been done by TCO. [32]

The autonomous chemical injection valve FloWizard can offer commercial potential and added value due to:

- More flexible and reliable chemical injection methods.
- Increased flow ranges and flow rates.
- Possibilities for automation, remote operation and subsea application.
- Reduced manufacture and maintenance cost.

The mechanism that adjusts the valve opening is external resulting in less wear. In addition, increased flow rates and flow ranges results in no need for replacement and calibration of the valve when flow volume varies. It makes the valve more suitable for automation and

remote operation. The valve is also smaller and lighter easing the transport to and from offshore installations. [31]

During the development of FloWizard, the design has changed. Initially, the valve had an internal flow set point. The first restriction is now an external valve as shown in figure 25. To ease automation and remote operation, the flow through FloWizard is adjusted with the external regulator valve. The adjustment is thus made exterior from the pressure regulating component in the valve system. The first restriction is not manufactured by TCO, but valves from other manufactures can be to FloWizard and act as an external valve. In the experiments in this thesis, the needle valve HOKE 1335G4Y and the ball valve Swagelok SS-41GS2 was connected to FloWizard.

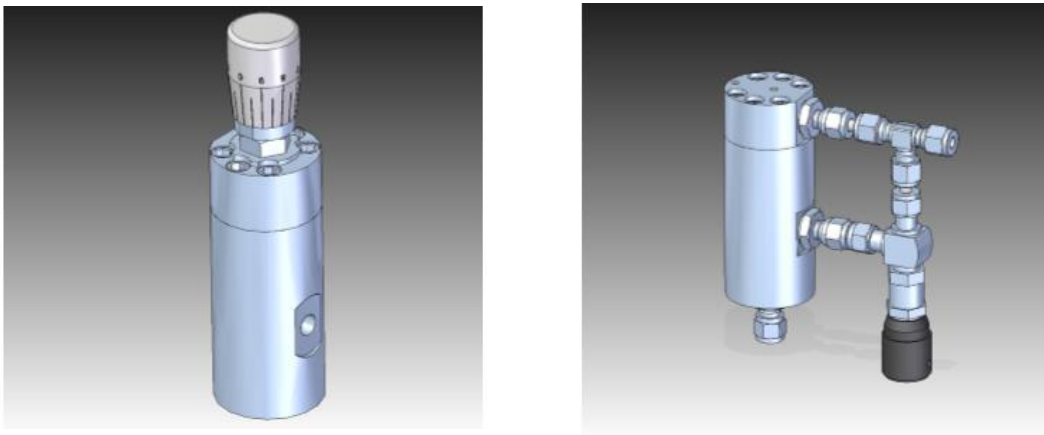

Figure 25. FloWizard with internal and external throttling valve

3 Experimental Method and Results

3.1 Introduction

The effect of changes in temperature was examined in SkoFlo and FloWizard. Tap water was injected, and the water temperature was changed between approximately 15°C and 57°C. Engineer Mehmed Nazecic was responsible for the experimental set-up and conduction of the experiments.

3.2 Analysis

3.2.1 SkoFlo

The effect of changed temperature on desired flowrate was examined. SkoFlo maintains a constant differential pressure across a fixed calibrated orifice which results in a constant flow through that orifice. The orifice is installed into a piston and uses springs to set a constant differential pressure across the piston/orifice assembly, thus maintaining a constant flow. The flow rate is set by adjusting the spring force on the piston by turning the rate adjustment handle.

3.2.2 FloWizard

The effect of changed temperature on desired flowrate was examined. FloWizard will be commercialized by the company TCO. The valves consist of two restrictions providing constant flow. The desired flow rate is set at the first restriction where a constant pressure differential is achieved across the restriction, and the compensation part compensates for changes in pressure at the inlet or outlet of the valve. Changes in pressure is countered by the second restriction by movement of a spring loaded piston acting on a needle in a nozzle. The first restriction is not manufactured by TCO, but a valve from HOKE/Swagelok is connected to FloWizard. The following external valves was used in the experiment:

3.2.2.1 HOKE 1335G4Y

HOKE 1335G4Y 1300 series includes an orifice of size 1.19 mm with a spring loaded standard 1° stem. The product specifications are listed in the following table:

Flow pattern	Body material	Operating pressure range	Operating temperature range	Connections	C _v
Globe	Stainless steel	345 bar at 21°C	- 54 to 232°C	¼" Gyrolok	0.010

Table 2. Product specifications for HOKE 1335G4Y [33]

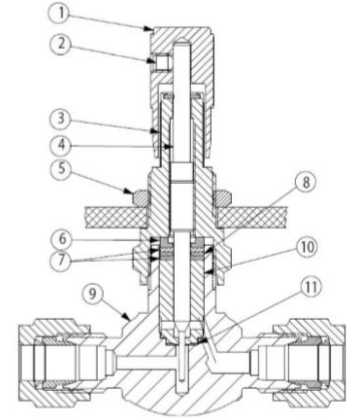
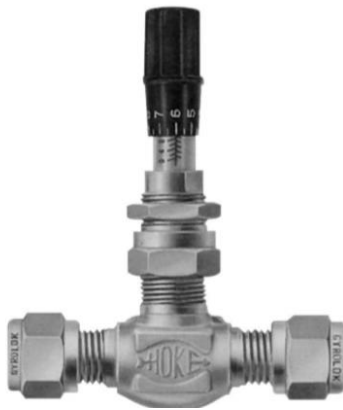

Figure 26. HOKE 1335G4Y metering valve [33]

3.2.2.2 Swagelok SS-41GS2

Swagelok SS-41GS2's product specifications are given in the following table:

Orifice	Body material	Max operating pressure	Max operating temperature	Connections	C _v
2.4 mm	Stainless steel	172 bar at 37°C	147°C at 172 bar	1/8"	0.02

Table 3. Product specifications for Swagelok SS-41GS2 [34]



Figure 27. Swagelok SS-41GS2 ball valve [34]

3.2.3 LabVIEW Software System

LabVIEW was used to measure the flowrate. LabVIEW (Laboratory Virtual Instrumentation Engineering Workbench) is a software system from National Instruments. LabVIEW was designed to support laboratory work and it is typically used for data acquisition, control and monitoring of equipment. The programming language used in LabVIEW is called G and is based on data availability. A function is executed if there is enough data available. [35]

3.2.4 Kärcher K7 Premium Ecologic Home

Kärcher K7 Premium is a pressure washer produced by Kärcher. In the experiments, the pressure washer pumped the water at higher pressures to the valve arrangement where

pressure is limited before reaching FloWizard/SkoFlo. Product specifications is given in the following table:

Pressure range	Flow rate	Max water feed temperature	Power rating
20-160 bar	600 L/h	60 °C	2,8 kW

Table 4. Product specifications for Kächer K7 Premium [36]

The pump has a self-preserving function that seizes the pump to function when operated at pressures over 147 bars.

3.3 Method

Tap water was transported through a plastic tubing to a pressure piston pump that pumped the water at higher pressures and velocities to a steel pipe connected to a valve arrangement including a relief valve, a pressure gauge and FloWizard/SkoFlo. The relief valve controlled and limited the pressure in the system by allowing pressurized fluid to flow out of the system and into the sink. The pressure gauge displayed the pressure obtained by the relief valve. The flowrate was set at the control valve FloWizard/SkoFlo by turning the stem handle on the valves. The water flowed through the control valve, through a second plastic tubing and into beaker placed on an electronic weight. The weight was connected to a computer with the software LabVIEW that was programmed to measures the increasing weight as flow rate. The water temperature was measured with a thermometer. In the experiments with SkoFlo, the inlet and outlet temperature were measured. In the experiments with FloWizard, the temperature was measured at the spring and at the outlet.

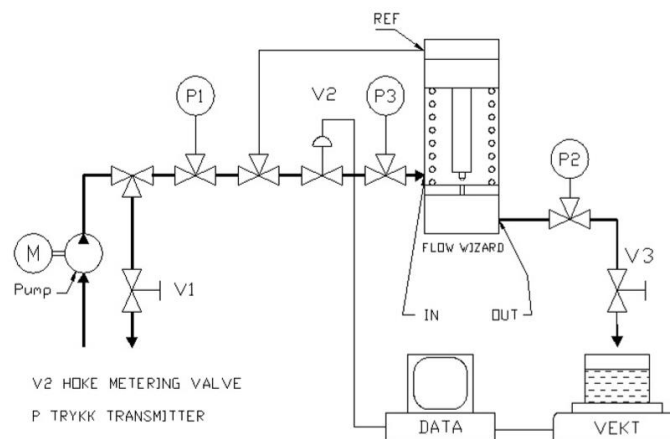

Figure 28. Experimental setup by Mehmed Nazecic [27]

One weight measurement was done by LabVIEW every second in all tests but one where a weight measurement was performed every 6th second. The flowrate was found by assuming a water density of 1000 kg/m³ and applying mass flowrate which is defined by the limit:

$$\omega(t) = \lim_{\Delta t \rightarrow 0} \frac{\Delta m}{\Delta t}$$

$\omega(t)$ mass flowrate [kg/s]

Δm differential mass [kg]

Δt differential time [s]

- The water temperature was changed between approximately 15°C and 57°C at the water faucet. It will be explained in the following how the temperature was changed.
- The inlet pressure was set to 120 bar and the outlet pressure was set to 0 bar in all tests.
- FloWizard was calibrated with 3 needle turns.
- For the statistical analysis, average flowrate, standard deviation and relative standard deviation was calculated using both the measured flowrate for every second and using the average flowrate over 6 seconds as 1-6 s, 7-12 s etc. The latter was done to even out the variation associated with individual droplets falling into the beaker.

3.4 Statistical analysis

3.4.1 Sample mean

The sample mean is a statistical measure used to derive the central tendency in a collection of data. The measure tells the average flowrate and thus it provides an indication of the degree of deviation from the desired flowrate.

$$\bar{x} = \frac{1}{n} \sum_{i=1}^n x_i$$

\bar{x} sample mean

x_i sample number i

n number of samples

3.4.2 Moving average

Moving average smooths of volatility and help to show trends. Simple moving average is calculated by adding the last n data points and dividing by n. The moving average used in this thesis is the average of the six previous measurements.

$$SMV = \frac{1}{n} \sum_{i=0}^{n-1} x_{i-1}$$

3.4.3 Standard deviation

Standard deviation was used to quantify of amount of variation in the data set. It was thus a measure of how spread the flowrate measurements was from the average flowrate.

$$\sigma = \sqrt{\frac{1}{n} \cdot \sum_{i=1}^n (x_i - \bar{x})^2}$$

σ standard deviation

3.4.4 Relative standard deviation (RSD)

RSD is given in percentage and tells how spread the data are around the mean. Thus, it tells whether the standard deviation is a small or large quantity when compared to the mean flowrate.

$$RSD = \frac{\sigma}{|\bar{x}|} \cdot 100$$

RSD relative standard deviation

$|\bar{x}|$ absolute value of sample mean

3.5 Results

3.5.1 SkoFlo

3.5.1.1 SkoFlo test 1

The total measuring time was 28 minutes and 47 seconds (1727 s). The flowrate was set to 0.2 L/min. At first, the inlet temperature was held constant at 57°C for approximately 5 minutes and 17 seconds allowing the flowrate to stabilize. The temperature was then gradually decreased to 11°C as seen in figure 29. The red curve is the simple moving average, thus the average flowrate over the previous 6 seconds. From the curve, it is seen that the flowrate decreases slightly with temperature. The effect is minimal however.

The temperature is initially approximately 57°C at the inlet and the outlet. As the temperature is decreased at the water faucet, a temperature difference develops between the inlet and the outlet because the water is heated by the system as it flows through the valve. The inlet and outlet temperature would stabilize at approximately the same temperature if the test had been run for a longer period. The explanation to the region with lack of flowrate data is that the beaker collecting the water had to be emptied. Thus, there are no weight measurements for that period. After the beaker is set on the weight again, the flowrate fluctuates before it appears to stabilize at a slightly higher flowrate than before the beaker was removed. It is not clear if the results after the beaker is emptied are reliable as the trend was decreasing flowrate until the beaker was emptied.

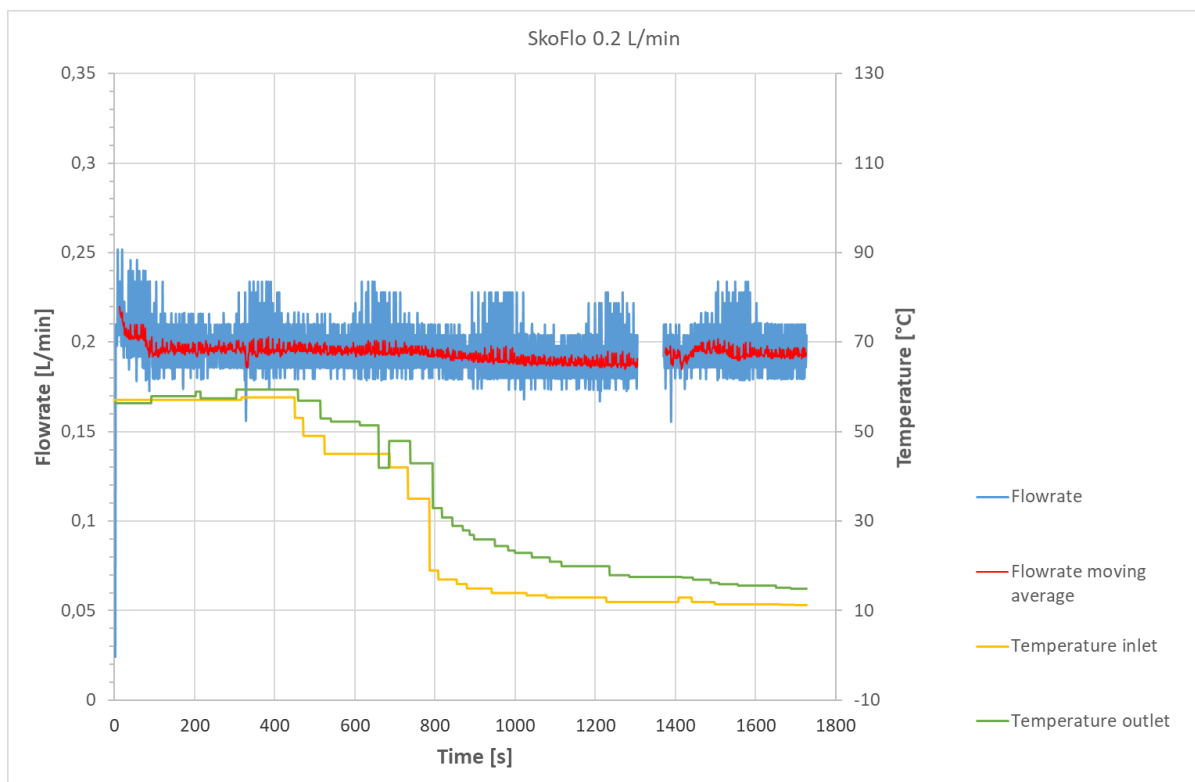

Figure 29. SkoFlo test 1

For the statistical analysis, the test was divided into three ranges: (1) where the temperature stabilized at 57°C, (2) where the temperature decreased, (3) where the inlet temperature curve began to flat out at 11-12°C. The entire range is also included in the following table. First the calculations using measured flowrate for every second is given, then the calculations when using the average flowrate over 6 seconds is given.

Measuring range [s]	150-450	451-1230	1231-1727	150-1727
Average flowrate [L/min]	0.19586711	0.1923462	0.1928453	0.1930173
Standard deviation	0.01320056	0.0130403	0.0136602	0.0133755
Relative standard deviation [%]	6.73954872	6.7795998	7.0835192	6.9296667
Average flowrate [L/min]	0.19588235	0.1924	0.1927606	0.1932064
Standard deviation	0.00229789	0.0033273	0.0034045	0.0034476
Relative standard deviation [%]	1.17309459	1.7293537	1.7661760	1.7844168

Table 5. SkoFlo test 1

The first range starts after 150 seconds to avoid the fluctuations in flowrate seen at start-up. The fluctuations after the beaker is emptied is included in the third range resulting in a higher standard deviation. The deviation between the set flowrate and the flowrate averages for the ranges in the experiment will depend on the temperature the device is calibrated for. The interesting aspect is thus not how much the averages deviates from the set flowrate, but the variation in the data set.

From the table, it is seen that the average flowrate is 0.193 L/min, the standard deviation is 0.0133 and the relative standard deviation is 6.930 % in the experiment. A relative standard deviation of 3-4 % can be accepted. The standard deviation is thus acceptable when averaging over 6 seconds.

3.5.1.2 SkoFlo test 2

Total measuring time was 36 minutes and 7 seconds (2167 s). The flowrate was set to 0.2 L/min. At first, the inlet temperature was held at about 15°C for approximately 6 minutes and 26 seconds allowing the flowrate to stabilize. Then, the temperature was gradually increased from 15°C to 57°C. The flowrate increases slightly with temperature as seen in figure 30.

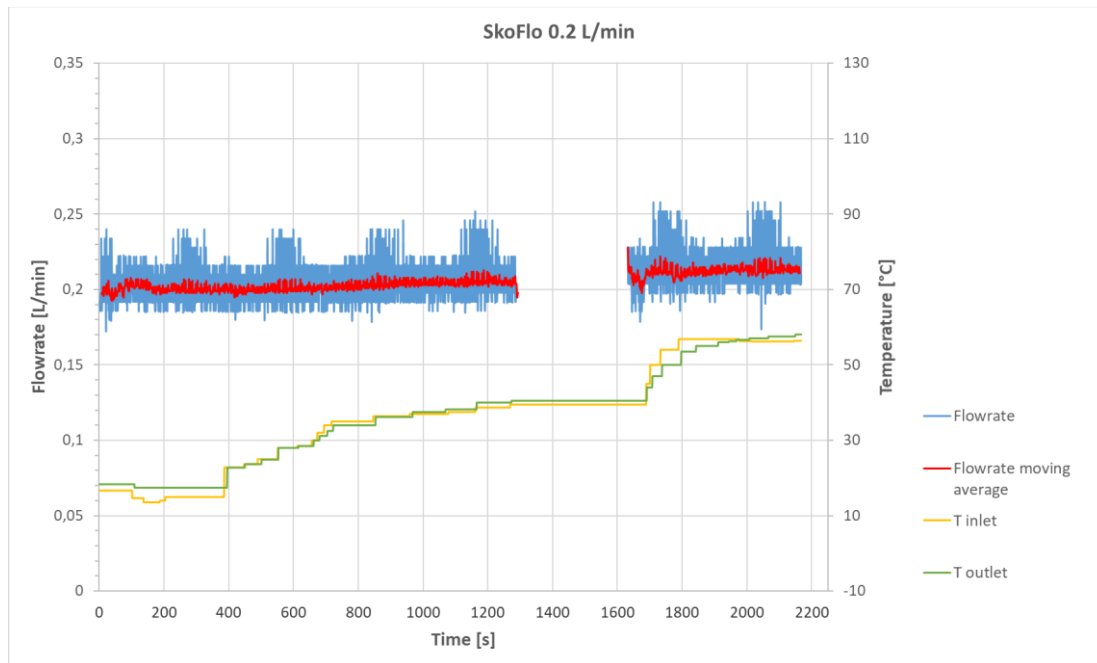

Figure 30. SkoFlo test 2

For the statistical analysis, the test was divided into three ranges: (1) where the temperature stabilized at 15°C eventually, (2) where the temperature increased, (3) where the inlet temperature stabilized at 56°C. First the calculations using measured flowrate for every second is given, then the calculations when using the average flowrate over 6 seconds is given.

Measuring range [s]	150-386	387-1789	1790-2167	150-2167
Average flowrate [L/min]	0.2002532	0.2037054	0.2125692	0.2051763
Standard deviation	0.0131187	0.0141375	0.0142687	0.0146336
Relative standard deviation [%]	6.5585262	6.9401522	6.7124902	7.1322167
Average flowrate [L/min]	0.2	0.2037	0.2125806	0.2051379
Standard deviation	0.0020976	0.0039935	0.0021064	0.0053945
Relative standard deviation [%]	1.0488089	1.9604771	0.9908848	2.6297051

Table 6. SkoFlo test 2

The flowrate fluctuations seen in the seconds range due to emptying of the beaker, results in a higher standard deviation for that range compared to the first and the third range. The average flowrate is 0.205 L/min, the standard deviation is 0.0146 and the relative standard deviation is 7.132 % for calculations using measuring point for every second. When averaging over 6 seconds, the relative standard deviation is less than the acceptable 3 %.

3.5.1.3 SkoFlo test 3

Total measuring time was 22 minutes and 14 seconds (1334 s). The flowrate was set to 0.2 L/min. At first, the inlet temperature was held constant at 10-12°C for approximately 11 minutes and 5 seconds. Then, the water temperature was set to 54°C at the water faucet. It is seen in figure 31 that the flowrate increases slightly when the temperature is increased.

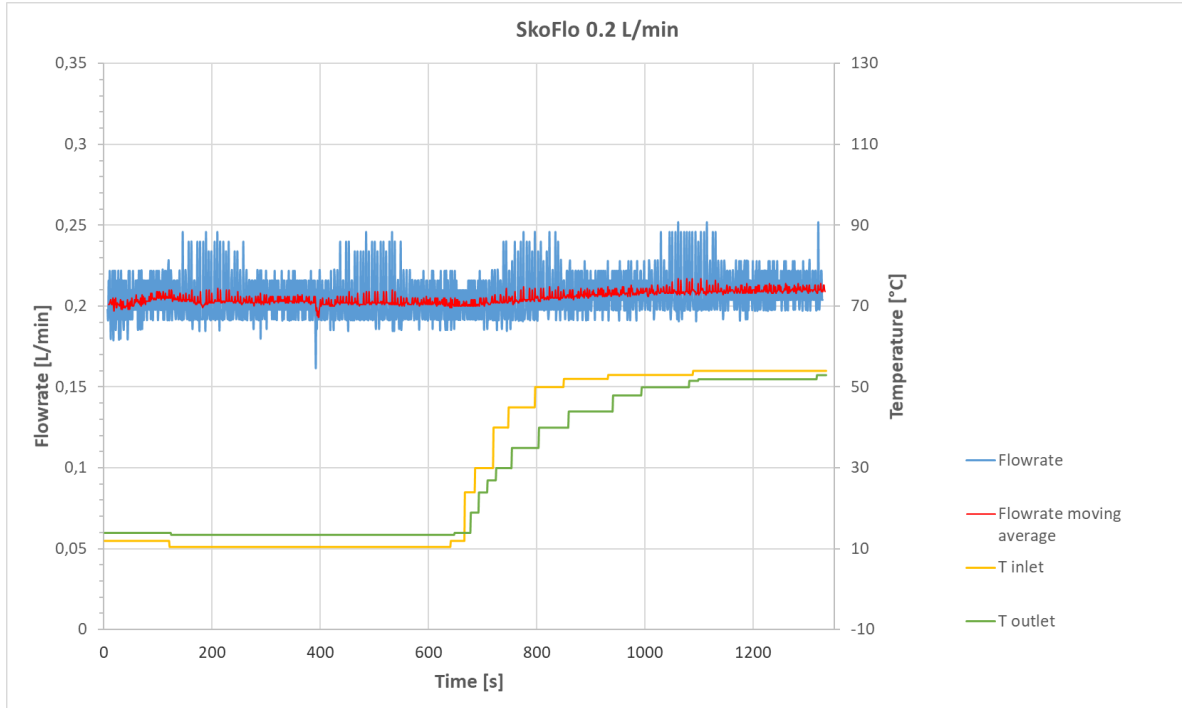

Figure 31. SkoFlo test 3

The measurement range was divided into three for the analysis: (1) where the temperature stabilized at 10 °C, (2) where the temperature increased, (3) where the temperature stabilized at 54 °C.

Measuring range [s]	150-640	641-1088	1089-1334	150-1334
Average flowrate [L/min]	0.202716904	0.20615625	0.209853659	0.20549873
Standard deviation	0.014123376	0.01387324	0.012465682	0.01396349
Relative standard deviation [%]	6.967044135	6.72947596	5.940178365	6.79492853
Average flowrate [L/min]	0.202670732	0.20613333	0.209853659	0.20546970
Standard deviation	0.002135957	0.00348457	0.001690158	0.00380411
Relative standard deviation [%]	1.053905219	1.69044429	0.80539824	1.85142470

Table 7. SkoFlo test 3

From the table, it is seen that the average flowrate is 0.203 L/min, the standard deviation is 0.0140 and the relative standard deviation is 6.795 % over the entire measuring range. When averaging over 6 seconds, the standard deviation is acceptable being less than 3 %. The measuring points can be seen in Appendix A.

3.5.2 FloWizard

3.5.2.1 FloWizard test 1

- The flow rate was set to 1 L/min at the external setting point, HOKE 1335G4Y.
- A weight measurement was performed in LabVIEW every 6th second.
- The temperature was measured at the spring and at the outlet.

The water temperature was gradually increased over 54 minutes and 12 seconds (3252 s) from 15-57°C. The temperature was measured at the spring and at the outlet. The flowrate appears to increase to some extent with temperature as seen in figure 32. The measuring points can be seen in Appendix B.

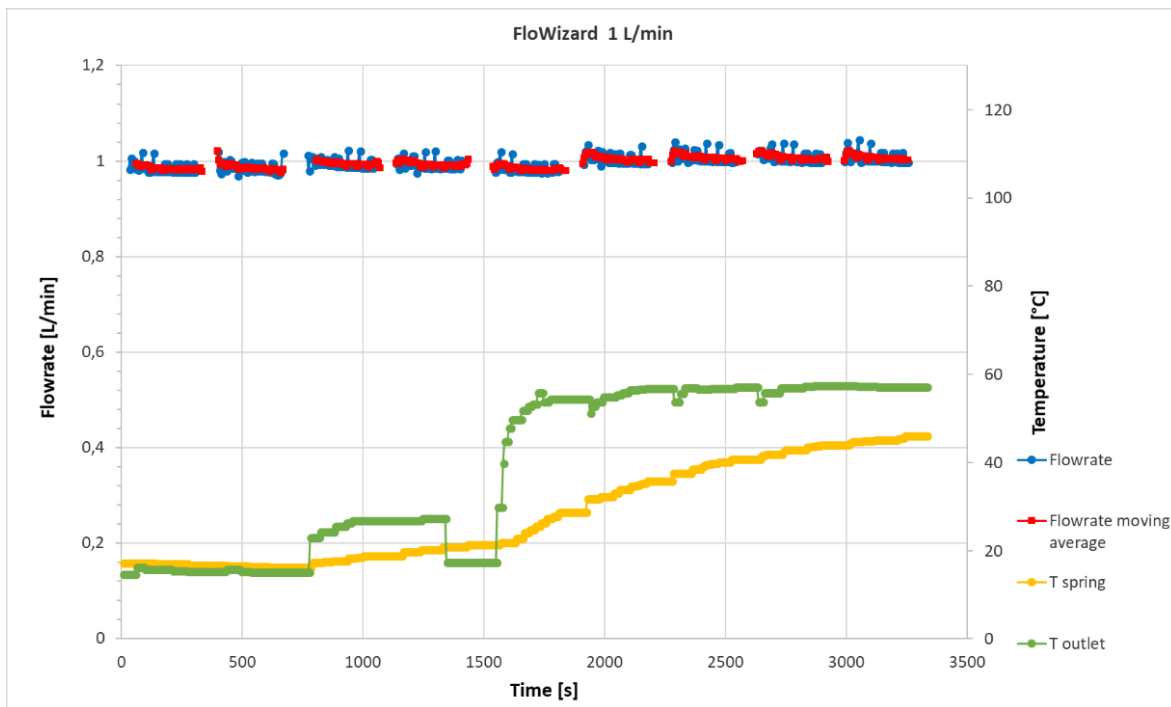

Figure 32. FloWizard test 1

Let's take a closer look at the measuring point. The beaker was emptied every 264th. The observed flowrate pattern after the beaker is placed on the weight again after being emptied, is identical to test 1 and 2 for SkoFlo. However, as seen in figure 33, the flowrate is never allowed to stabilize before the beaker is removed again. The results cannot give a reliable average flowrate, but the trend is clear. The flowrate increases with increasing temperature.

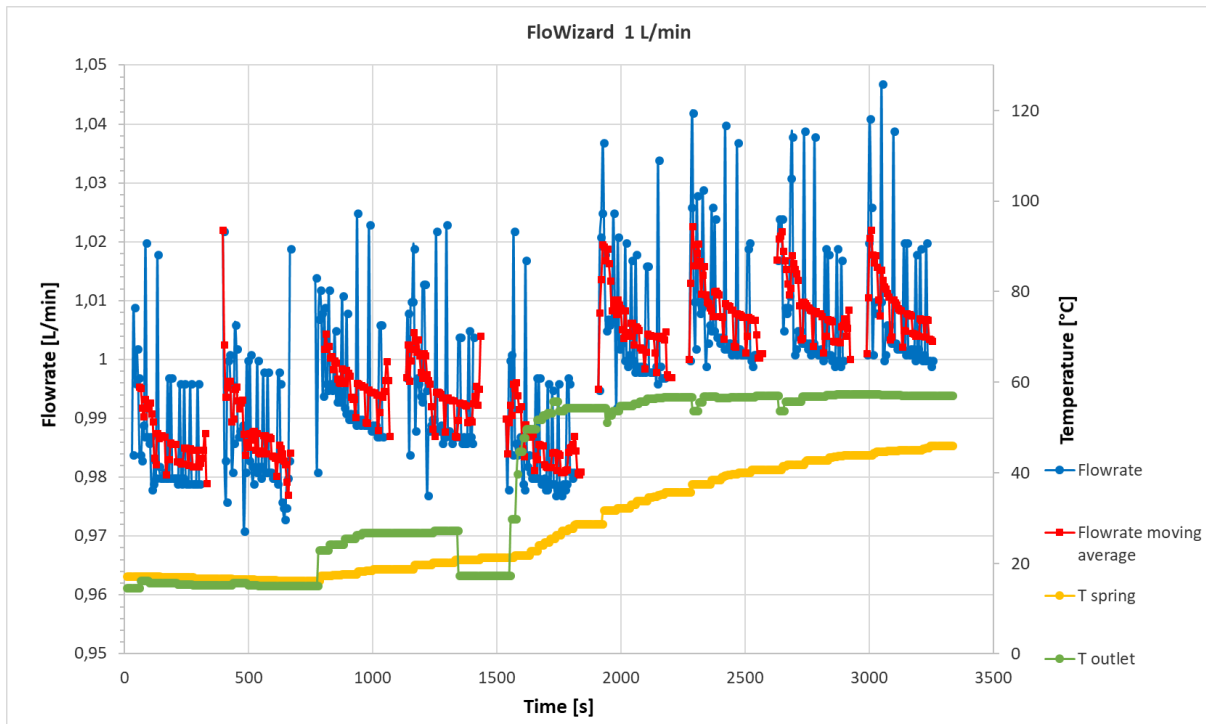

Figure 33. FloWizard test 1

For the statistical analysis, the test was divided into three ranges: (1) where the temperature stabilized at 15°C eventually, (2) where the temperature increased, (3) where the outlet temperature stabilized at 56-57°C. Only one set of calculations are presented since measurements were performed every 6th second.

Measuring range [s]	150-774	775-2100	2001-3252	150-3252
Average flowrate [L/min]	0.986573333	0.995	1.008109589	0.9983
Standard deviation	0.010839647	0.01277833	0.011607817	0.014510111
Relative standard deviation [%]	1.098716844	1.28425426	1.15144396	1.453482061

Table 8. FloWizard test 1

The average flowrate over the entire measuring range is 0.9983 L/min, the standard deviation is 0.0145 and the relative standard deviation is 1.453 %, which is acceptable.

3.5.2.2 FloWizard test 2-4

Several tests were performed on FloWizard. Unfortunately, the results were corrupted due to decreasing inlet pressure during the experiments and what appears to be incorrect calibration. The results must thus be seen as a combined effect of changing temperature and decreasing pressure. Three of the tests are presented in the following. The temperature is increased in the tests. In contrast to the previous tests, there are no clear trends.

3.5.2.3 FloWizard test 2

The flow rate was set to 0.2 L/min at the external setting point, HOKE 1335G4Y. Total measuring time was 24 minutes and 3 seconds (1443 s). The water temperature at the inlet was held constant at approximately 12-13°C for 9 minutes before the water faucet was set to 55°C. The result is displayed in figure 34:

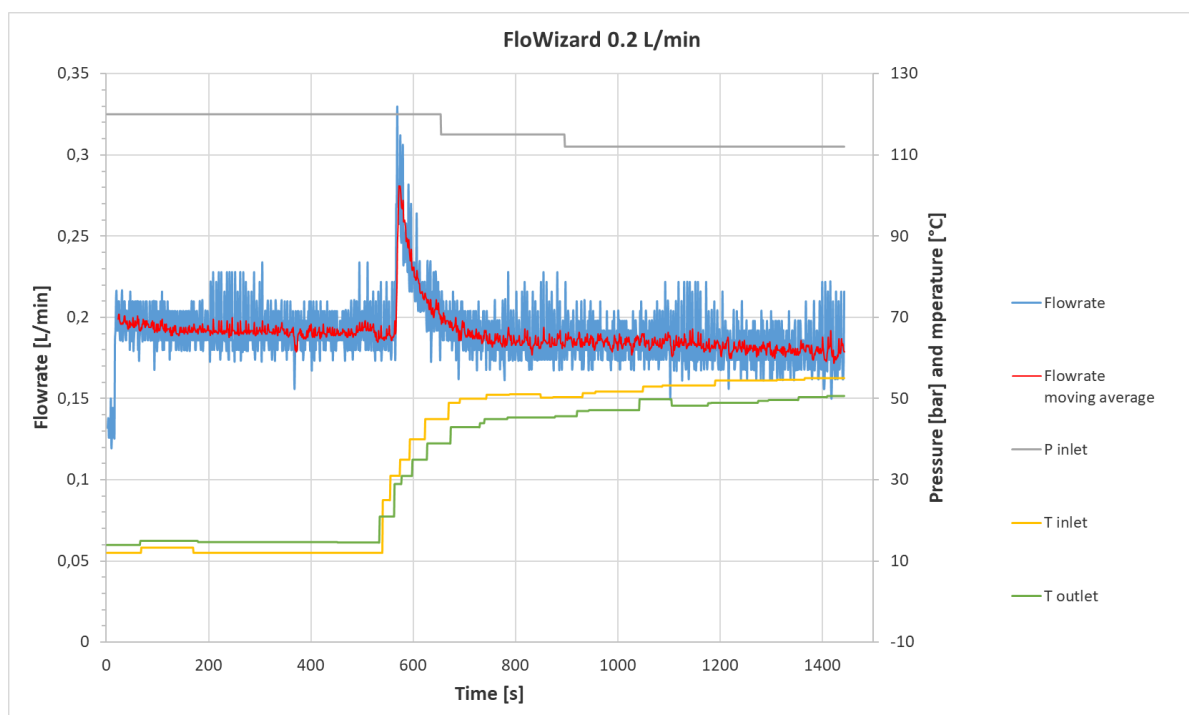

Figure 34. FloWizard test 2

The flowrate increases rapidly after the water temperature is set to 55°C before it stabilizes after approximately 3 minutes. It is not known what causes the sudden increase. The flowrate stabilizes at a slightly lower value than at the initial temperature. However, the pressure also decreases after the temperature is increased and the changed flowrate must be seen as a combined effect of temperature and pressure.

For the statistical analysis, the test was divided into three ranges: (1) where the temperature stabilized at 12°C eventually, (2) where the temperature increased, (3) where the inlet temperature curve started to flatten out at 51°C.

Measuring range [s]	150-541	542-932	932-1443	150-1443
Average flowrate [L/min]	0.1912041	0.196512	0.1822896	0.189288
Standard deviation	0.0131226	0.024998	0.0138748	0.018794
Relative standard deviation [%]	6.8631503	12.72072	7.6114228	9.928982
Average flowrate [L/min]	0.1912424	0.196554	0.1823177	0.189329
Standard deviation	0.0027472	0.019995	0.0032583	0.012766
Relative standard deviation [%]	1.4365188	10.17299	1.7871748	6.742769

Table 9. FloWizard test 2

The standard deviation is high in the second interval where the temperature is set to 55°C, and it affects the overall standard deviation. The average flowrate is reduced from 0.191 L/min in the first range to 0.182 L/min in the third range.

FloWizard test 3

The flow rate was set to 0.2 L/min at the external setting point, HOKE 1335G4Y. Total measuring time was 27 minutes and 9 seconds (1629 s). The water temperature at the inlet was held constant at approximately 11-12°C for 10 minutes before the water faucet was set to 55°C. The result is displayed in figure 35:

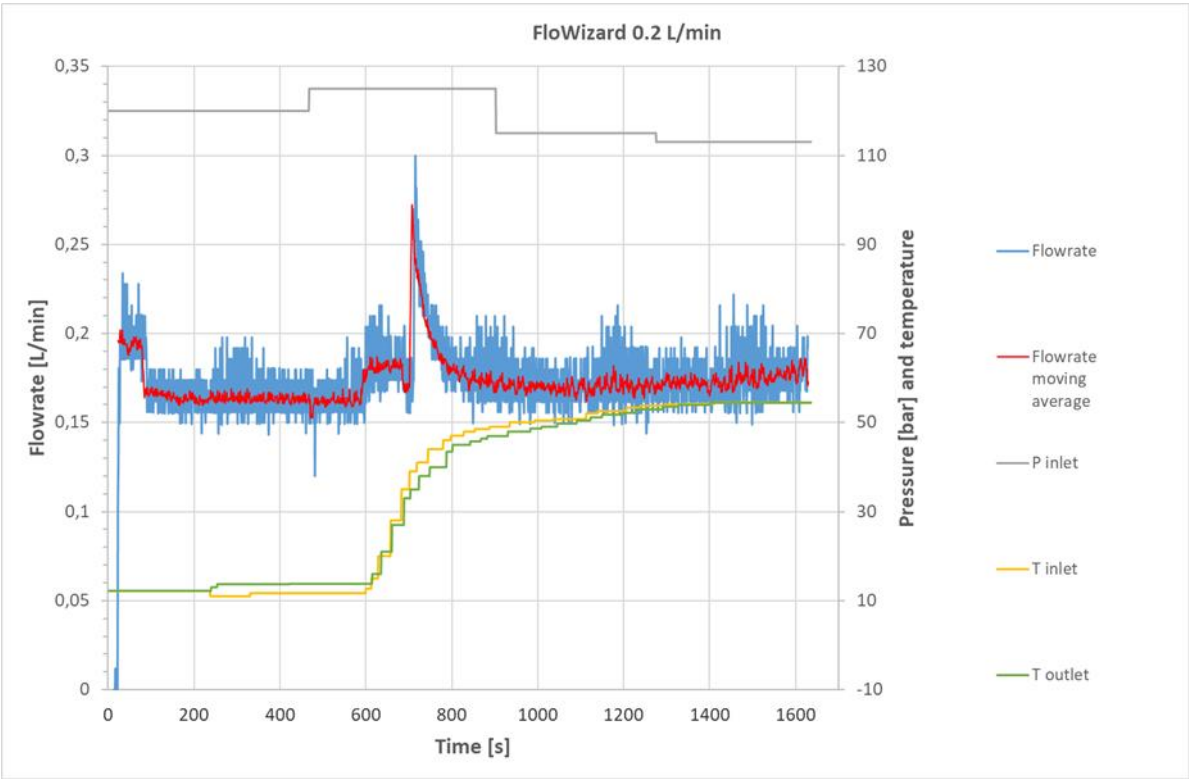

Figure 35. FloWizard test 3

As in test 2, the flowrate increases rapidly after the water temperature is set to 55°C before it stabilizes after approximately 3 minutes. The flowrate stabilizes at a slightly lower value than at the initial temperature. An interesting aspect is that the flowrate increases after the inlet pressure decreases from 115 bar to 113 bar after 1275 seconds.

For the statistical analysis, the test was divided into three ranges: (1) where the temperature stabilized at 12°C eventually, (2) where the temperature increased, (3) where the inlet temperature curve started to flat out at 51°C.

Measuring range [s]	150-600	601-1113	1114-1629	150-1629
Average flowrate [L/min]	0.16317073	0.179497076	0.17298837	0.172252703
Standard deviation	0.01162437	0.021115967	0.01376125	0.017479979
Relative standard deviation [%]	7.12405556	11.76396146	7.95501353	10.14786904
Average flowrate [L/min]	0.163171053	0.1796	0.17293023	0.172222672
Standard deviation	0.003155564	0.01765233	0.00429112	0.012681517
Relative standard deviation [%]	1.933899293	9.82869077	2.48141866	7.363442001

Table 10. FloWizard test 3

The average flowrate shows a deviation from the desired flowrate of in all intervals 0.2 L/min. The explanation to the deviation is most likely that the valve has been incorrectly calibrated. The standard deviation is high in the second interval where the temperature is set to 55°C, and it affects the overall standard deviation.

FloWizard test 4

The total measuring time was 27 minutes and 52 seconds (1672 s) for the second test. In this test the external setting point Swagelok SS-41GS2 is used to set the flowrate at 0.2 L/min. The water temperature was set to 53°C at the water faucet after approximately 10 minutes. The result is seen in figure 36.

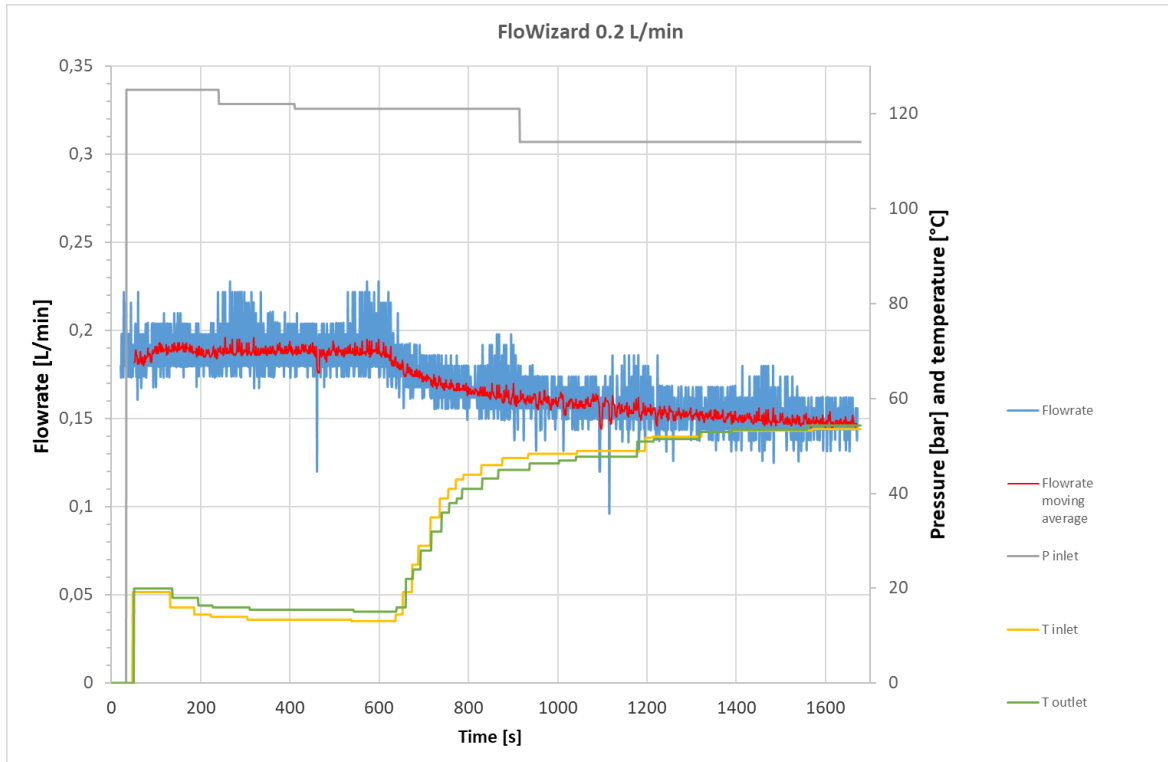

Figure 36. FloWizard test 4

It is seen that inlet pressure isn't constant throughout the test. At first, when the temperature is increased, the inlet pressure is constant at 121 bar and the decreased flowrate must be a result of the increased temperature. However, the inlet pressure decreases from 121 to 114 bar after 914 seconds. The flowrate after 914 seconds is thus also a result of the decreased pressure.

For the statistical analysis, the test was divided into three ranges: (1) where the temperature stabilized at 15°C eventually, (2) where the temperature increased, (3) where the outlet temperature stabilized at 52-53°C.

Measuring range [s]	150-633	634-1196	1197-1672	150-1672
Average flowrate [L/min]	0.187822314	0.16302309	0.15012605	0.16687328
Standard deviation	0.013395195	0.01321624	0.01071717	0.01975029
Relative standard deviation [%]	7.131844073	8.10697645	7.13878306	11.8355011
Average flowrate [L/min]	0.187756098	0.16287097	0.150050633	0.166917323
Standard deviation	0.002796169	0.00708508	0.003534264	0.016060082
Relative standard deviation [%]	1.489255961	4.35012043	2.355380672	9.621578979

Table 11. FloWizard test 4

The average flowrate shows a deviation from the desired flowrate of 0.2 L/min. Swagelok SS-41GS2 is sensitive at low flowrates and difficult to adjust. The explanation to the deviation is likely that the valve has not been set to the correct flowrate. When averaging over 6 seconds, the relative standard deviation is 9.62 %. It is more than the accepted 3 %, but the value can have been affected by the change in pressure.

3.5.3 Comparison of SkoFlo and FloWizard

SkoFlo test 1-4 and FloWizard test 1 was compared. The flowrate was 0.2 L/min for SkoFlo, whereas it was 1 L/min for FloWizard. The test for FloWizard was also run for a longer time. Since the tests aren't performed under the same conditions, the findings are only guiding. Test 2-4 for FloWizard was not included in the comparison because the pressure was not held constant. The change in flowrate was thus a combined effect of temperature and pressure.

The flowrate increased with temperature in all tests. The absolute change in percent between the first time interval where the initial temperature was constant and the third time interval where the final temperature stabilized is presented in the following graph:

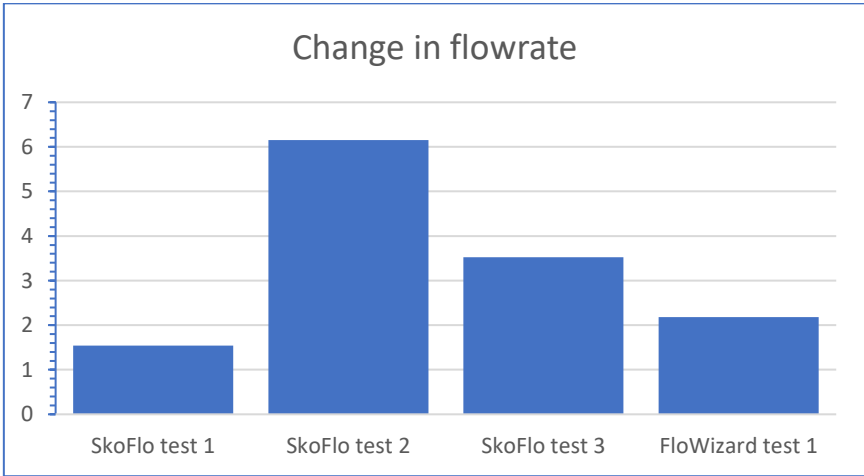

Figure 37. Comparison

The temperature was decreased in SkoFlo test 1, and thus the flowrate decreased. The water temperature was increased in the other tests, thus the flowrate increased. The change in percent for SkoFlo is 1.54 %, 6.15 % and 3.52 % for test 1,2 and 3 respectively. The emptying of the beaker in test 1 and 2 can be the explanation to difference. When studying the graphs from the experiments, the flowrate appears to increase after the beaker is placed back on the weight. It is evident in SkoFlo test 1. If correct, it means that the change in percent for SkoFlo test 1 would be smaller because it would counter for the effect of decreasing temperature. The opposite would be the case for test 2. More tests must however be performed to confirm the suspicions. FloWizard test 1 changes with 2.18 %.

3.5.4 Reliability of the measurements

3.5.4.1 Restoring of Beaker

When the beaker was filled with water, it was removed from the weight and emptied. When it was restored, it was observed that the flowrate oscillated and appeared to stabilize at a higher value than the previous flowrate.

3.5.4.2 Flowrate calculation

The calculation of the flowrate is based on the weight measurements, and a density of 1000 kg/m³ is assumed for water. However, the density of water at 0 bar where the weight is measured is 999.19 kg/m³ at 15°C, and 985.65 kg/m³ at 55°C. There is a weight measurement every second. To illustrate the effect, a weight measurement of 3.33 kg converts to 0.2 m³/min if a density of 1000 kg/m³ is assumed. The difference is insignificant at 15°C. However, a weight measurement of 3.33 kg converts to 0.2029 m³/min at 55°C.

3.5.4.3 Systematic error

In all tests, it is observed that the flowrate varies more between constant time intervals. It must therefore be a systematic error for the instruments. It increases the overall uncertainty.

4 Conclusions

4.1 Concluding Remarks

The objective of the thesis was to examine the effect of temperature on autonomous injection valves. Water was injected in the chemical injection valves SkoFlo and FloWizard. The flowrate was measured during temperature increase/decrease.

From the experiments it can be concluded that the effect of temperature change is small in both SkoFlo and FloWizard. The result for FloWizard can be implemented for BECH AFD since the constant flow principle is the same. The experiments confirm the expectations. Flow through valves is mainly turbulent, thus the pressure loss is density controlled. Water is considered compressible and the change in density with temperature is small, thus the effect of temperature on flowrate is small.

In SkoFlo, it was observed an increased flowrate with temperature. In FloWizard, on the other hand, the flowrate increased with temperature in two tests and decreased with temperature in the other two tests. The decrease of flowrate with temperature can be caused by the calibration of the valve. The results also suggested incorrect calibration in some of the tests for FloWizard. More tests should be performed to find out what caused the rapid increase in flowrate when the temperature was increased in test 2 and 3 for FloWizard.

No conclusions can be made to whether SkoFlo or FloWizard handles changes in temperature conditions best. Repeatable tests should be performed with constant parameters to be able to distinguish the products.

4.2 Further Work

A drawback was the lack of repeatability in the tests. The tests must be performed under the same conditions, and several tests should be performed to account for uncertainty and establish a trend over time. For further work I would suggest developing a procedure to ensure comparable data.

The inlet temperature and outlet temperature differed from test to test as a water facet was used to set the temperature. To ensure same inlet temperature and rate of temperature change in all tests, a possibility can be to use a laboratory water bath that can circulate water to external systems. Laboratory water baths provide stable temperature control.

Data points were lost when the beaker was emptied for water during the tests, and results suggested that the flow didn't stabilize at the correct value after the beaker was placed on the weight again. It is therefore suggested to use a container that can hold all water injected in the valve throughout the test.

The measuring time in the tests differed. In addition, it was observed that the inlet and outlet temperature hadn't stabilized before the temperature was changed or the test was finished in some tests. It is therefore suggested to use equal measuring time for all tests, and ensure sufficient time for the flowrate and temperature through the valve to stabilize after the temperature has been set.

In all tests but one for FloWizard, the inlet pressure decreased. Either a better system for controlling pressure must be established, or tests must be repeated if the pressure isn't held constant throughout the test.

Finally, another interesting aspect for further investigation is to test the effect of temperature when gas is injected. Water is assumed incompressible, and the changes in density with temperature is insignificant. For gases, however, the volume expands with higher temperature and contracts with lower temperature. Injecting gas can thus make it possible to distinguish SkoFlo and FloWizard when temperature is changed.

If gas shall be injected, changes in density with temperature must be accounted for or a new system for measuring the flowrate must be developed since the system used is based on weight measurements where density is assumed constant.

References

1. Skousen, P.L., *Valve Handbook* Second ed. 2004: McGraw-Hill
2. Manufacturing, C. *How Does a Needle Valve Work?* 2017.
3. Cengel, Y.A., J.M. Cimbala, and R.H. Turner, *Fundamentals of Thermal-Fluid Sciences* Fourth ed. 2012: McGraw-Hill Education.
4. Walter, F. *Which Turbulence Model Should I Choose for My CFD Application?* 2017; Available from: <https://www.comsol.com/blogs/which-turbulence-model-should-choose-cfd-application/>.
5. Aadnoy, B.S. and G. Hareland, *Analysis of Inflow Control Devices* SPE 122824, 2009.
6. Nesbitt, B., *Handbook of Valves and Actuators* 2007: Elsevier.
7. Software, V. *Density of liquid water from 0 °C to 100 °C*. Available from: http://www.vaxasoftware.com/doc_eduen/qui/denh2o.pdf.
8. Bybee, K., *Production Operations: Inflow-Control Devices* Society of Petroleum Engineers, 2008.
9. Berge, C., *Troll Field - Completion Solutions Applied*. World Petroleum Congress, 2011.
10. Moen, T. and H.A. Asheim, *Inflow Control Device and Near-Wellbore Interaction*. SPE 112471, 2008.
11. Todman, S., G. Wood, and M.D. Jackson, *Modelling and Optimizing Inflow Control Devices*. Society of Petroleum Engineers, 2017.
12. Daneshy, A.A., et al., *Inflow-Control-Device Design: Revisiting Objectives and Techniques* Society of Petroleum Engineers 2012.
13. Eltahir, E., et al., *Autonomous Inflow Control Valve - their modelling and "added value"* Society of Petroleum Engineers, 2014.
14. Jadhav, N. and D. Zhambrovskii, *Electrical Resistivity Autonomous Inflow Control Device ER-AICD*. Society of Petroleum Engineers, 2017.
15. Halvorsen, M., et al., *Enhanced Oil Recovery On Troll Field By Implementing Autonomous Inflow Control Device*. Society of Petroleum Engineers, 2016.
16. Ellis, T., A. Erkal, and G. Goh, *Inflow Control Devices: Raising Profiles* Oilfield Review, 2010. **21**(4).
17. Bellarby, J., *Well Completion design* 2009: Elsevier.
18. Bowen, E.G. and B.S. Aadnoy, *A Quasi Intelligent Flow Control Device for Water Injectors*. Society of Petroleum Engineers, 2014.
19. Zeng, Q., et al., *A Novel Autonomous Inflow Control Device Design: Improvements to Hybrid ICD*. International Petroleum Technology Conference, 2014.
20. Li, Z. and P.X.Z. Fernandes, D. , *Understanding the Roles of Inflow-Control Devices in Optimizing Horizontal-Well Performance* Society of Petroleum Engineers, 2011.
21. Fripp, M., L. Zhao, and B. Least, *The Theory of a Fluidic Diode Autonomous Inflow Control Device*. Society of Petroleum Engineers, 2013.
22. Aadnoy, B.S. *Autonomous Flow Control Valve or "intelligent" ICD* 2008; Available from: http://www.hansenenergy.biz/HANSEN_Energy_Solutions/InflowControl2008B.pdf.
23. Companies, A. *CHEMICAL INJECTION SYSTEMS BENEFITING OIL AND GAS PRODUCERS*. 2014.
24. Duhon, H.J. and K.M. Annadorai, *Successful Application of Chemical Injection Rate Control Valves*. Society of Petroleum Engineers, 2007.
25. Guerra, L.A.D.O. and G.H. Oliveira, *Designing Downhole Chemical Injection Systems*. Society of Petroleum Engineers, 2014.
26. Stewart-Liddon, C., et al., *Qualification of Chemicals/Chemical Injection Systems for Downhole Continuous Chemical Injection* Society of Petroleum Engineers, 2014.
27. Risa, I., *Automated Chemical Injection*. 2015, University of Stavanger p. 85.
28. Gate. *Chemical injection rate control valves* 2010.
29. *Injection Valve Technologies* 2018; Available from: <http://www.skoflo.com/injection-valve-technologies.cfm>.

30. Molven, M., *Report for FloWizard Chemical Injection Valve* 2011.
31. *Utviklet "magisk" ventil*. 2014; Available from: <http://www.uis.no/samfunn-og-naeringsliv/samarbeid-med-oss/utviklet-magisk-ventil-article86845-10641.html>.
32. TCO. *TCO acquisition of topside chemical injection flow control valve technology* 2015; Available from: <http://www.tcogroup.com/news-archive/tco-acquisition-of-topside-chemical-injection-flow-control-valve-technology-article54-35.html>.
33. *HOKE Metering Valves* Available from: http://www.hoke.com/pdf/metering_valves_catalog_79013_10.12.pdf.
34. *SS-41GS2*. 2018; Available from: <https://www.swagelok.com/en/catalog/Product/Detail?part=SS-41GS2>.
35. Halvorsen, H. *Introduction to LabVIEW*. 2016; Available from: <http://home.hit.no/~hansha/documents/labview/training/Introduction%20to%20LabVIEW/Introduction%20to%20LabVIEW.pdf>.
36. *K7 Premium Ecologic Home*. 2018; Available from: https://s1.kaercher-media.com/documents/datasheets/machines/en_GB/1.168-175.0_PI_en_GB.pdf.

Appendix A

Measurements for SkoFlo test 3 where temperature was increased:

Time [s]	Flowrate [L/min]	Weight [kg]	P inlet [bar]	P outlet [bar]	Temperature inlet [°C]	Temperature outlet [°C]	Moving average [L/min]
1	5.856	97.6	120	0	12	14	
2	0.042	98.3	120	0	12	14	
3	0.216	101.9	120	0	12	14	
4	0.192	105.1	120	0	12	14	
5	0.216	108.7	120	0	12	14	
6	0.192	111.9	120	0	12	14	
7	0.198	115.2	120	0	12	14	
8	0.192	118.4	120	0	12	14	0.201
9	0.216	122	120	0	12	14	0.201
10	0.198	125.3	120	0	12	14	0.202
11	0.222	129	120	0	12	14	0.203
12	0.198	132.3	120	0	12	14	0.204
13	0.18	135.3	120	0	12	14	0.201
14	0.21	138.8	120	0	12	14	0.20228571
15	0.198	142.1	120	0	12	14	0.201
16	0.222	145.8	120	0	12	14	0.205
17	0.192	149	120	0	12	14	0.2
18	0.18	152	120	0	12	14	0.197
19	0.222	155.7	120	0	12	14	0.204
20	0.192	158.9	120	0	12	14	0.201
21	0.222	162.6	120	0	12	14	0.205
22	0.186	165.7	120	0	12	14	0.199
23	0.192	168.9	120	0	12	14	0.199
24	0.198	172.2	120	0	12	14	0.202
25	0.216	175.8	120	0	12	14	0.201
26	0.192	179	120	0	12	14	0.201
27	0.222	182.7	120	0	12	14	0.201
28	0.18	185.7	120	0	12	14	0.2
29	0.198	189	120	0	12	14	0.201
30	0.216	192.6	120	0	12	14	0.204
31	0.18	195.6	120	0	12	14	0.198
32	0.222	199.3	120	0	12	14	0.203
33	0.192	202.5	120	0	12	14	0.198
34	0.192	205.7	120	0	12	14	0.2
35	0.216	209.3	120	0	12	14	0.203
36	0.192	212.5	120	0	12	14	0.199
37	0.186	215.6	120	0	12	14	0.2
38	0.216	219.2	120	0	12	14	0.199
39	0.192	222.4	120	0	12	14	0.199
40	0.198	225.7	120	0	12	14	0.2
41	0.216	229.3	120	0	12	14	0.2
42	0.192	232.5	120	0	12	14	0.2
43	0.21	236	120	0	12	14	0.204
44	0.18	239	120	0	12	14	0.198
45	0.192	242.2	120	0	12	14	0.198
46	0.222	245.9	120	0	12	14	0.202
47	0.192	249.1	120	0	12	14	0.198

48	0.222	252.8	120	0	12	14	0.203
49	0.192	256	120	0	12	14	0.2
50	0.192	259.2	120	0	12	14	0.202
51	0.21	262.7	120	0	12	14	0.205
52	0.192	265.9	120	0	12	14	0.2
53	0.192	269.1	120	0	12	14	0.2
54	0.222	272.8	120	0	12	14	0.2
55	0.198	276.1	120	0	12	14	0.201
56	0.21	279.6	120	0	12	14	0.204
57	0.198	282.9	120	0	12	14	0.202
58	0.198	286.2	120	0	12	14	0.203
59	0.216	289.8	120	0	12	14	0.207
60	0.198	293.1	120	0	12	14	0.203
61	0.198	296.4	120	0	12	14	0.203
62	0.216	300	120	0	12	14	0.204
63	0.186	303.1	120	0	12	14	0.202
64	0.198	306.4	120	0	12	14	0.202
65	0.222	310.1	120	0	12	14	0.203
66	0.186	313.2	120	0	12	14	0.201
67	0.222	316.9	120	0	12	14	0.205
68	0.186	320	120	0	12	14	0.2
69	0.204	323.4	120	0	12	14	0.203
70	0.222	327.1	120	0	12	14	0.207
71	0.186	330.2	120	0	12	14	0.201
72	0.216	333.8	120	0	12	14	0.206
73	0.198	337.1	120	0	12	14	0.202
74	0.192	340.3	120	0	12	14	0.203
75	0.216	343.9	120	0	12	14	0.205
76	0.198	347.2	120	0	12	14	0.201
77	0.198	350.5	120	0	12	14	0.203
78	0.216	354.1	120	0	12	14	0.203
79	0.198	357.4	120	0	12	14	0.203
80	0.192	360.6	120	0	12	14	0.203
81	0.216	364.2	120	0	12	14	0.203
82	0.198	367.5	120	0	12	14	0.203
83	0.216	371.1	120	0	12	14	0.206
84	0.198	374.4	120	0	12	14	0.203
85	0.198	377.7	120	0	12	14	0.203
86	0.222	381.4	120	0	12	14	0.208
87	0.192	384.6	120	0	12	14	0.204
88	0.222	388.3	120	0	12	14	0.208
89	0.198	391.6	120	0	12	14	0.205
90	0.198	394.9	120	0	12	14	0.205
91	0.192	398.1	120	0	12	14	0.204
92	0.222	401.8	120	0	12	14	0.204
93	0.198	405.1	120	0	12	14	0.205
94	0.216	408.7	120	0	12	14	0.204
95	0.198	412	120	0	12	14	0.204
96	0.198	415.3	120	0	12	14	0.204
97	0.222	419	120	0	12	14	0.209
98	0.198	422.3	120	0	12	14	0.205
99	0.222	426	120	0	12	14	0.209
100	0.192	429.2	120	0	12	14	0.205
101	0.198	432.5	120	0	12	14	0.205
102	0.222	436.2	120	0	12	14	0.209
103	0.198	439.5	120	0	12	14	0.205

104	0.216	443.1	120	0	12	14	0.208
105	0.198	446.4	120	0	12	14	0.204
106	0.204	449.8	120	0	12	14	0.206
107	0.198	453.1	120	0	12	14	0.206
108	0.216	456.7	120	0	12	14	0.205
109	0.222	460.4	120	0	12	14	0.209
110	0.192	463.6	120	0	12	14	0.205
111	0.204	467	120	0	12	14	0.206
112	0.192	470.2	120	0	12	14	0.204
113	0.222	473.9	120	0	12	14	0.208
114	0.198	477.2	120	0	12	14	0.205
115	0.222	480.9	120	0	12	14	0.205
116	0.198	484.2	120	0	12	14	0.206
117	0.198	487.5	120	0	12	14	0.205
118	0.192	490.7	120	0	12	14	0.205
119	0.222	494.4	120	0	12	14	0.205
120	0.228	498.2	120	0	12	14	0.21
121	0.192	501.4	120	0	10.5	14	0.205
122	0.198	504.7	120	0	10.5	14	0.205
123	0.198	508	120	0	10.5	14	0.205
124	0.222	511.7	120	0	10.5	13.5	0.21
125	0.216	515.3	120	0	10.5	13.5	0.209
126	0.192	518.5	120	0	10.5	13.5	0.203
127	0.198	521.8	120	0	10.5	13.5	0.204
128	0.198	525.1	120	0	10.5	13.5	0.204
129	0.216	528.7	120	0	10.5	13.5	0.207
130	0.204	532.1	120	0	10.5	13.5	0.204
131	0.216	535.7	120	0	10.5	13.5	0.204
132	0.198	539	120	0	10.5	13.5	0.205
133	0.192	542.2	120	0	10.5	13.5	0.204
134	0.198	545.5	120	0	10.5	13.5	0.204
135	0.216	549.1	120	0	10.5	13.5	0.204
136	0.216	552.7	120	0	10.5	13.5	0.206
137	0.204	556.1	120	0	10.5	13.5	0.204
138	0.192	559.3	120	0	10.5	13.5	0.203
139	0.198	562.6	120	0	10.5	13.5	0.204
140	0.222	566.3	120	0	10.5	13.5	0.208
141	0.21	569.8	120	0	10.5	13.5	0.207
142	0.192	573	120	0	10.5	13.5	0.203
143	0.204	576.4	120	0	10.5	13.5	0.203
144	0.198	579.7	120	0	10.5	13.5	0.204
145	0.192	582.9	120	0	10.5	13.5	0.203
146	0.246	587	120	0	10.5	13.5	0.207
147	0.192	590.2	120	0	10.5	13.5	0.204
148	0.192	593.4	120	0	10.5	13.5	0.204
149	0.198	596.7	120	0	10.5	13.5	0.203
150	0.198	600	120	0	10.5	13.5	0.203
151	0.222	603.7	120	0	10.5	13.5	0.208
152	0.216	607.3	120	0	10.5	13.5	0.203
153	0.198	610.6	120	0	10.5	13.5	0.204
154	0.192	613.8	120	0	10.5	13.5	0.204
155	0.198	617.1	120	0	10.5	13.5	0.204
156	0.198	620.4	120	0	10.5	13.5	0.204
157	0.24	624.4	120	0	10.5	13.5	0.207
158	0.192	627.6	120	0	10.5	13.5	0.203
159	0.198	630.9	120	0	10.5	13.5	0.203

160	0.198	634.2	120	0	10.5	13.5	0.204
161	0.192	637.4	120	0	10.5	13.5	0.203
162	0.24	641.4	120	0	10.5	13.5	0.21
163	0.204	644.8	120	0	10.5	13.5	0.204
164	0.186	647.9	120	0	10.5	13.5	0.203
165	0.198	651.2	120	0	10.5	13.5	0.203
166	0.192	654.4	120	0	10.5	13.5	0.202
167	0.216	658	120	0	10.5	13.5	0.206
168	0.216	661.6	120	0	10.5	13.5	0.202
169	0.198	664.9	120	0	10.5	13.5	0.201
170	0.192	668.1	120	0	10.5	13.5	0.202
171	0.192	671.3	120	0	10.5	13.5	0.201
172	0.198	674.6	120	0	10.5	13.5	0.202
173	0.24	678.6	120	0	10.5	13.5	0.206
174	0.192	681.8	120	0	10.5	13.5	0.202
175	0.198	685.1	120	0	10.5	13.5	0.202
176	0.198	688.4	120	0	10.5	13.5	0.203
177	0.186	691.5	120	0	10.5	13.5	0.202
178	0.24	695.5	120	0	10.5	13.5	0.209
179	0.192	698.7	120	0	10.5	13.5	0.201
180	0.192	701.9	120	0	10.5	13.5	0.201
181	0.192	705.1	120	0	10.5	13.5	0.2
182	0.192	708.3	120	0	10.5	13.5	0.199
183	0.192	711.5	120	0	10.5	13.5	0.2
184	0.24	715.5	120	0	10.5	13.5	0.2
185	0.198	718.8	120	0	10.5	13.5	0.201
186	0.192	722	120	0	10.5	13.5	0.201
187	0.198	725.3	120	0	10.5	13.5	0.202
188	0.186	728.4	120	0	10.5	13.5	0.201
189	0.246	732.5	120	0	10.5	13.5	0.21
190	0.192	735.7	120	0	10.5	13.5	0.202
191	0.192	738.9	120	0	10.5	13.5	0.201
192	0.198	742.2	120	0	10.5	13.5	0.202
193	0.198	745.5	120	0	10.5	13.5	0.202
194	0.234	749.4	120	0	10.5	13.5	0.21
195	0.198	752.7	120	0	10.5	13.5	0.202
196	0.192	755.9	120	0	10.5	13.5	0.202
197	0.198	759.2	120	0	10.5	13.5	0.203
198	0.192	762.4	120	0	10.5	13.5	0.202
199	0.234	766.3	120	0	10.5	13.5	0.208
200	0.198	769.6	120	0	10.5	13.5	0.202
201	0.198	772.9	120	0	10.5	13.5	0.202
202	0.192	776.1	120	0	10.5	13.5	0.202
203	0.198	779.4	120	0	10.5	13.5	0.202
204	0.198	782.7	120	0	10.5	13.5	0.203
205	0.24	786.7	120	0	10.5	13.5	0.204
206	0.192	789.9	120	0	10.5	13.5	0.203
207	0.198	793.2	120	0	10.5	13.5	0.203
208	0.192	796.4	120	0	10.5	13.5	0.203
209	0.198	799.7	120	0	10.5	13.5	0.203
210	0.246	803.8	120	0	10.5	13.5	0.211
211	0.192	807	120	0	10.5	13.5	0.203
212	0.192	810.2	120	0	10.5	13.5	0.203
213	0.204	813.6	120	0	10.5	13.5	0.204
214	0.186	816.7	120	0	10.5	13.5	0.203
215	0.24	820.7	120	0	10.5	13.5	0.21

216	0.198	824	120	0	10.5	13.5	0.202
217	0.198	827.3	120	0	10.5	13.5	0.203
218	0.192	830.5	120	0	10.5	13.5	0.203
219	0.198	833.8	120	0	10.5	13.5	0.202
220	0.192	837	120	0	10.5	13.5	0.203
221	0.24	841	120	0	10.5	13.5	0.203
222	0.198	844.3	120	0	10.5	13.5	0.203
223	0.192	847.5	120	0	10.5	13.5	0.202
224	0.198	850.8	120	0	10.5	13.5	0.203
225	0.198	854.1	120	0	10.5	13.5	0.203
226	0.234	858	120	0	10.5	13.5	0.21
227	0.198	861.3	120	0	10.5	13.5	0.203
228	0.198	864.6	120	0	10.5	13.5	0.203
229	0.192	867.8	120	0	10.5	13.5	0.203
230	0.198	871.1	120	0	10.5	13.5	0.203
231	0.24	875.1	120	0	10.5	13.5	0.21
232	0.192	878.3	120	0	10.5	13.5	0.203
233	0.198	881.6	120	0	10.5	13.5	0.203
234	0.198	884.9	120	0	10.5	13.5	0.203
235	0.192	888.1	120	0	10.5	13.5	0.203
236	0.216	891.7	120	0	10.5	13.5	0.206
237	0.222	895.4	120	0	10.5	13.5	0.203
238	0.192	898.6	120	0	10.5	13.5	0.203
239	0.192	901.8	120	0	10.5	13.5	0.202
240	0.198	905.1	120	0	10.5	13.5	0.202
241	0.198	908.4	120	0	10.5	13.5	0.203
242	0.234	912.3	120	0	10.5	13.5	0.206
243	0.198	915.6	120	0	10.5	13.5	0.202
244	0.198	918.9	120	0	10.5	13.5	0.203
245	0.192	922.1	120	0	10.5	13.5	0.203
246	0.198	925.4	120	0	10.5	13.5	0.203
247	0.234	929.3	120	0	10.5	13.5	0.209
248	0.198	932.6	120	0	10.5	13.5	0.203
249	0.198	935.9	120	0	10.5	13.5	0.203
250	0.192	939.1	120	0	10.5	13.5	0.202
251	0.192	942.3	120	0	10.5	13.5	0.202
252	0.222	946	120	0	10.5	13.5	0.206
253	0.21	949.5	120	0	10.5	13.5	0.202
254	0.192	952.7	120	0	10.5	13.5	0.201
255	0.198	956	120	0	10.5	13.5	0.201
256	0.198	959.3	120	0	10.5	13.5	0.202
257	0.192	962.5	120	0	10.5	13.5	0.202
258	0.24	966.5	120	0	10.5	13.5	0.205
259	0.198	969.8	120	0	10.5	13.5	0.203
260	0.198	973.1	120	0	10.5	13.5	0.204
261	0.192	976.3	120	0	10.5	13.5	0.203
262	0.192	979.5	120	0	10.5	13.5	0.202
263	0.216	983.1	120	0	10.5	13.5	0.206
264	0.222	986.8	120	0	10.5	13.5	0.203
265	0.192	990	120	0	10.5	13.5	0.202
266	0.198	993.3	120	0	10.5	13.5	0.202
267	0.198	996.6	120	0	10.5	13.5	0.203
268	0.21	1000.1	120	0	10.5	13.5	0.206
269	0.216	1003.7	120	0	10.5	13.5	0.206
270	0.198	1007	120	0	10.5	13.5	0.202
271	0.198	1010.3	120	0	10.5	13.5	0.203

272	0.192	1013.5	120	0	10.5	13.5	0.202
273	0.216	1017.1	120	0	10.5	13.5	0.205
274	0.192	1020.3	120	0	10.5	13.5	0.202
275	0.216	1023.9	120	0	10.5	13.5	0.202
276	0.198	1027.2	120	0	10.5	13.5	0.202
277	0.186	1030.3	120	0	10.5	13.5	0.2
278	0.204	1033.7	120	0	10.5	13.5	0.202
279	0.216	1037.3	120	0	10.5	13.5	0.202
280	0.216	1040.9	120	0	10.5	13.5	0.206
281	0.198	1044.2	120	0	10.5	13.5	0.203
282	0.192	1047.4	120	0	10.5	13.5	0.202
283	0.192	1050.6	120	0	10.5	13.5	0.203
284	0.222	1054.3	120	0	10.5	13.5	0.206
285	0.216	1057.9	120	0	10.5	13.5	0.206
286	0.192	1061.1	120	0	10.5	13.5	0.202
287	0.198	1064.4	120	0	10.5	13.5	0.202
288	0.198	1067.7	120	0	10.5	13.5	0.203
289	0.222	1071.4	120	0	10.5	13.5	0.208
290	0.18	1074.4	120	0	10.5	13.5	0.201
291	0.222	1078.1	120	0	10.5	13.5	0.202
292	0.198	1081.4	120	0	10.5	13.5	0.203
293	0.192	1084.6	120	0	10.5	13.5	0.202
294	0.198	1087.9	120	0	10.5	13.5	0.202
295	0.216	1091.5	120	0	10.5	13.5	0.201
296	0.216	1095.1	120	0	10.5	13.5	0.207
297	0.198	1098.4	120	0	10.5	13.5	0.203
298	0.192	1101.6	120	0	10.5	13.5	0.202
299	0.198	1104.9	120	0	10.5	13.5	0.203
300	0.222	1108.6	120	0	10.5	13.5	0.207
301	0.186	1111.7	120	0	10.5	13.5	0.202
302	0.216	1115.3	120	0	10.5	13.5	0.202
303	0.198	1118.6	120	0	10.5	13.5	0.202
304	0.198	1121.9	120	0	10.5	13.5	0.203
305	0.21	1125.4	120	0	10.5	13.5	0.205
306	0.198	1128.7	120	0	10.5	13.5	0.201
307	0.216	1132.3	120	0	10.5	13.5	0.206
308	0.198	1135.6	120	0	10.5	13.5	0.203
309	0.198	1138.9	120	0	10.5	13.5	0.203
310	0.216	1142.5	120	0	10.5	13.5	0.206
311	0.192	1145.7	120	0	10.5	13.5	0.203
312	0.216	1149.3	120	0	10.5	13.5	0.206
313	0.198	1152.6	120	0	10.5	13.5	0.203
314	0.192	1155.8	120	0	10.5	13.5	0.202
315	0.198	1159.1	120	0	10.5	13.5	0.202
316	0.222	1162.8	120	0	10.5	13.5	0.203
317	0.192	1166	120	0	10.5	13.5	0.203
318	0.216	1169.6	120	0	10.5	13.5	0.203
319	0.198	1172.9	120	0	10.5	13.5	0.203
320	0.192	1176.1	120	0	10.5	13.5	0.203
321	0.216	1179.7	120	0	10.5	13.5	0.206
322	0.198	1183	120	0	10.5	13.5	0.202
323	0.216	1186.6	120	0	10.5	13.5	0.206
324	0.198	1189.9	120	0	10.5	13.5	0.203
325	0.198	1193.2	120	0	10.5	13.5	0.203
326	0.21	1196.7	120	0	10.5	13.5	0.206
327	0.198	1200	120	0	10.5	13.5	0.203

328	0.198	1203.3	120	0	10.5	13.5	0.203
329	0.222	1207	120	0	10.5	13.5	0.204
330	0.192	1210.2	120	0	10.5	13.5	0.203
331	0.198	1213.5	120	0	10.5	13.5	0.203
332	0.216	1217.1	120	0	10.5	13.5	0.204
333	0.192	1220.3	120	0	10.5	13.5	0.203
334	0.216	1223.9	120	0	10.5	13.5	0.206
335	0.198	1227.2	120	0	10.5	13.5	0.202
336	0.198	1230.5	120	0	10.5	13.5	0.203
337	0.21	1234	120	0	10.5	13.5	0.205
338	0.198	1237.3	120	0	10.5	13.5	0.202
339	0.216	1240.9	120	0	10.5	13.5	0.206
340	0.192	1244.1	120	0	10.5	13.5	0.202
341	0.198	1247.4	120	0	10.5	13.5	0.202
342	0.222	1251.1	120	0	10.5	13.5	0.206
343	0.192	1254.3	120	0	10.5	13.5	0.203
344	0.198	1257.6	120	0	10.5	13.5	0.203
345	0.216	1261.2	120	0	10.5	13.5	0.203
346	0.192	1264.4	120	0	10.5	13.5	0.203
347	0.198	1267.7	120	0	10.5	13.5	0.203
348	0.216	1271.3	120	0	10.5	13.5	0.202
349	0.192	1274.5	120	0	10.5	13.5	0.202
350	0.222	1278.2	120	0	10.5	13.5	0.206
351	0.192	1281.4	120	0	10.5	13.5	0.202
352	0.192	1284.6	120	0	10.5	13.5	0.202
353	0.222	1288.3	120	0	10.5	13.5	0.206
354	0.198	1291.6	120	0	10.5	13.5	0.203
355	0.192	1294.8	120	0	10.5	13.5	0.203
356	0.216	1298.4	120	0	10.5	13.5	0.202
357	0.198	1301.7	120	0	10.5	13.5	0.203
358	0.216	1305.3	120	0	10.5	13.5	0.207
359	0.198	1308.6	120	0	10.5	13.5	0.203
360	0.192	1311.8	120	0	10.5	13.5	0.202
361	0.216	1315.4	120	0	10.5	13.5	0.206
362	0.198	1318.7	120	0	10.5	13.5	0.203
363	0.216	1322.3	120	0	10.5	13.5	0.206
364	0.198	1325.6	120	0	10.5	13.5	0.203
365	0.198	1328.9	120	0	10.5	13.5	0.203
366	0.216	1332.5	120	0	10.5	13.5	0.207
367	0.192	1335.7	120	0	10.5	13.5	0.203
368	0.198	1339	120	0	10.5	13.5	0.203
369	0.216	1342.6	120	0	10.5	13.5	0.203
370	0.192	1345.8	120	0	10.5	13.5	0.202
371	0.204	1349.2	120	0	10.5	13.5	0.203
372	0.216	1352.8	120	0	10.5	13.5	0.203
373	0.192	1356	120	0	10.5	13.5	0.203
374	0.216	1359.6	120	0	10.5	13.5	0.206
375	0.198	1362.9	120	0	10.5	13.5	0.203
376	0.198	1366.2	120	0	10.5	13.5	0.204
377	0.21	1369.7	120	0	10.5	13.5	0.205
378	0.198	1373	120	0	10.5	13.5	0.202
379	0.216	1376.6	120	0	10.5	13.5	0.206
380	0.192	1379.8	120	0	10.5	13.5	0.202
381	0.198	1383.1	120	0	10.5	13.5	0.202
382	0.192	1386.3	120	0	10.5	13.5	0.201
383	0.222	1390	120	0	10.5	13.5	0.203

384	0.192	1393.2	120	0	10.5	13.5	0.202
385	0.216	1396.8	120	0	10.5	13.5	0.202
386	0.192	1400	120	0	10.5	13.5	0.202
387	0.198	1403.3	120	0	10.5	13.5	0.202
388	0.216	1406.9	120	0	10.5	13.5	0.206
389	0.198	1410.2	120	0	10.5	13.5	0.202
390	0.216	1413.8	120	0	10.5	13.5	0.206
391	0.192	1417	120	0	10.5	13.5	0.202
392	0.162	1419.7	120	0	10.5	13.5	0.197
393	0.21	1423.2	120	0	10.5	13.5	0.199
394	0.186	1426.3	120	0	10.5	13.5	0.194
395	0.216	1429.9	120	0	10.5	13.5	0.197
396	0.192	1433.1	120	0	10.5	13.5	0.193
397	0.192	1436.3	120	0	10.5	13.5	0.193
398	0.192	1439.5	120	0	10.5	13.5	0.198
399	0.222	1443.2	120	0	10.5	13.5	0.2
400	0.21	1446.7	120	0	10.5	13.5	0.204
401	0.192	1449.9	120	0	10.5	13.5	0.2
402	0.198	1453.2	120	0	10.5	13.5	0.201
403	0.192	1456.4	120	0	10.5	13.5	0.201
404	0.216	1460	120	0	10.5	13.5	0.205
405	0.198	1463.3	120	0	10.5	13.5	0.201
406	0.21	1466.8	120	0	10.5	13.5	0.201
407	0.192	1470	120	0	10.5	13.5	0.201
408	0.198	1473.3	120	0	10.5	13.5	0.201
409	0.192	1476.5	120	0	10.5	13.5	0.201
410	0.216	1480.1	120	0	10.5	13.5	0.201
411	0.216	1483.7	120	0	10.5	13.5	0.204
412	0.192	1486.9	120	0	10.5	13.5	0.201
413	0.192	1490.1	120	0	10.5	13.5	0.201
414	0.198	1493.4	120	0	10.5	13.5	0.201
415	0.216	1497	120	0	10.5	13.5	0.205
416	0.204	1500.4	120	0	10.5	13.5	0.203
417	0.198	1503.7	120	0	10.5	13.5	0.2
418	0.198	1507	120	0	10.5	13.5	0.201
419	0.186	1510.1	120	0	10.5	13.5	0.2
420	0.222	1513.8	120	0	10.5	13.5	0.204
421	0.192	1517	120	0	10.5	13.5	0.2
422	0.21	1520.5	120	0	10.5	13.5	0.201
423	0.192	1523.7	120	0	10.5	13.5	0.2
424	0.198	1527	120	0	10.5	13.5	0.2
425	0.186	1530.1	120	0	10.5	13.5	0.2
426	0.222	1533.8	120	0	10.5	13.5	0.2
427	0.216	1537.4	120	0	10.5	13.5	0.204
428	0.192	1540.6	120	0	10.5	13.5	0.201
429	0.198	1543.9	120	0	10.5	13.5	0.202
430	0.198	1547.2	120	0	10.5	13.5	0.202
431	0.21	1550.7	120	0	10.5	13.5	0.206
432	0.222	1554.4	120	0	10.5	13.5	0.206
433	0.192	1557.6	120	0	10.5	13.5	0.202
434	0.192	1560.8	120	0	10.5	13.5	0.202
435	0.198	1564.1	120	0	10.5	13.5	0.202
436	0.192	1567.3	120	0	10.5	13.5	0.201
437	0.24	1571.3	120	0	10.5	13.5	0.206
438	0.198	1574.6	120	0	10.5	13.5	0.202
439	0.198	1577.9	120	0	10.5	13.5	0.203

440	0.192	1581.1	120	0	10.5	13.5	0.203
441	0.192	1584.3	120	0	10.5	13.5	0.202
442	0.216	1587.9	120	0	10.5	13.5	0.206
443	0.216	1591.5	120	0	10.5	13.5	0.202
444	0.198	1594.8	120	0	10.5	13.5	0.202
445	0.198	1598.1	120	0	10.5	13.5	0.202
446	0.192	1601.3	120	0	10.5	13.5	0.202
447	0.192	1604.5	120	0	10.5	13.5	0.202
448	0.24	1608.5	120	0	10.5	13.5	0.206
449	0.192	1611.7	120	0	10.5	13.5	0.202
450	0.198	1615	120	0	10.5	13.5	0.202
451	0.198	1618.3	120	0	10.5	13.5	0.202
452	0.186	1621.4	120	0	10.5	13.5	0.201
453	0.24	1625.4	120	0	10.5	13.5	0.209
454	0.198	1628.7	120	0	10.5	13.5	0.202
455	0.192	1631.9	120	0	10.5	13.5	0.202
456	0.198	1635.2	120	0	10.5	13.5	0.202
457	0.192	1638.4	120	0	10.5	13.5	0.201
458	0.216	1642	120	0	10.5	13.5	0.206
459	0.216	1645.6	120	0	10.5	13.5	0.202
460	0.192	1648.8	120	0	10.5	13.5	0.201
461	0.198	1652.1	120	0	10.5	13.5	0.202
462	0.198	1655.4	120	0	10.5	13.5	0.202
463	0.192	1658.6	120	0	10.5	13.5	0.202
464	0.234	1662.5	120	0	10.5	13.5	0.205
465	0.198	1665.8	120	0	10.5	13.5	0.202
466	0.198	1669.1	120	0	10.5	13.5	0.203
467	0.192	1672.3	120	0	10.5	13.5	0.202
468	0.192	1675.5	120	0	10.5	13.5	0.201
469	0.234	1679.4	120	0	10.5	13.5	0.208
470	0.198	1682.7	120	0	10.5	13.5	0.202
471	0.192	1685.9	120	0	10.5	13.5	0.201
472	0.192	1689.1	120	0	10.5	13.5	0.2
473	0.198	1692.4	120	0	10.5	13.5	0.201
474	0.192	1695.6	120	0	10.5	13.5	0.201
475	0.234	1699.5	120	0	10.5	13.5	0.201
476	0.198	1702.8	120	0	10.5	13.5	0.201
477	0.192	1706	120	0	10.5	13.5	0.201
478	0.192	1709.2	120	0	10.5	13.5	0.201
479	0.198	1712.5	120	0	10.5	13.5	0.201
480	0.234	1716.4	120	0	10.5	13.5	0.208
481	0.192	1719.6	120	0	10.5	13.5	0.201
482	0.198	1722.9	120	0	10.5	13.5	0.201
483	0.192	1726.1	120	0	10.5	13.5	0.201
484	0.192	1729.3	120	0	10.5	13.5	0.201
485	0.246	1733.4	120	0	10.5	13.5	0.209
486	0.192	1736.6	120	0	10.5	13.5	0.202
487	0.192	1739.8	120	0	10.5	13.5	0.202
488	0.198	1743.1	120	0	10.5	13.5	0.202
489	0.192	1746.3	120	0	10.5	13.5	0.202
490	0.234	1750.2	120	0	10.5	13.5	0.209
491	0.198	1753.5	120	0	10.5	13.5	0.201
492	0.198	1756.8	120	0	10.5	13.5	0.202
493	0.192	1760	120	0	10.5	13.5	0.202
494	0.192	1763.2	120	0	10.5	13.5	0.201
495	0.198	1766.5	120	0	10.5	13.5	0.202

496	0.24	1770.5	120	0	10.5	13.5	0.203
497	0.192	1773.7	120	0	10.5	13.5	0.202
498	0.198	1777	120	0	10.5	13.5	0.202
499	0.192	1780.2	120	0	10.5	13.5	0.202
500	0.192	1783.4	120	0	10.5	13.5	0.202
501	0.24	1787.4	120	0	10.5	13.5	0.209
502	0.198	1790.7	120	0	10.5	13.5	0.202
503	0.186	1793.8	120	0	10.5	13.5	0.201
504	0.198	1797.1	120	0	10.5	13.5	0.201
505	0.198	1800.4	120	0	10.5	13.5	0.202
506	0.234	1804.3	120	0	10.5	13.5	0.209
507	0.198	1807.6	120	0	10.5	13.5	0.202
508	0.198	1810.9	120	0	10.5	13.5	0.202
509	0.186	1814	120	0	10.5	13.5	0.202
510	0.198	1817.3	120	0	10.5	13.5	0.202
511	0.198	1820.6	120	0	10.5	13.5	0.202
512	0.24	1824.6	120	0	10.5	13.5	0.203
513	0.192	1827.8	120	0	10.5	13.5	0.202
514	0.192	1831	120	0	10.5	13.5	0.201
515	0.198	1834.3	120	0	10.5	13.5	0.203
516	0.192	1837.5	120	0	10.5	13.5	0.202
517	0.24	1841.5	120	0	10.5	13.5	0.209
518	0.192	1844.7	120	0	10.5	13.5	0.201
519	0.192	1847.9	120	0	10.5	13.5	0.201
520	0.198	1851.2	120	0	10.5	13.5	0.202
521	0.198	1854.5	120	0	10.5	13.5	0.202
522	0.234	1858.4	120	0	10.5	13.5	0.209
523	0.198	1861.7	120	0	10.5	13.5	0.202
524	0.192	1864.9	120	0	10.5	13.5	0.202
525	0.192	1868.1	120	0	10.5	13.5	0.202
526	0.198	1871.4	120	0	10.5	13.5	0.202
527	0.192	1874.6	120	0	10.5	13.5	0.201
528	0.24	1878.6	120	0	10.5	13.5	0.202
529	0.192	1881.8	120	0	10.5	13.5	0.201
530	0.198	1885.1	120	0	10.5	13.5	0.202
531	0.192	1888.3	120	0	10.5	13.5	0.202
532	0.192	1891.5	120	0	10.5	13.5	0.201
533	0.246	1895.6	120	0	10.5	13.5	0.21
534	0.186	1898.7	120	0	10.5	13.5	0.201
535	0.198	1902	120	0	10.5	13.5	0.202
536	0.198	1905.3	120	0	10.5	13.5	0.202
537	0.186	1908.4	120	0	10.5	13.5	0.201
538	0.24	1912.4	120	0	10.5	13.5	0.209
539	0.198	1915.7	120	0	10.5	13.5	0.201
540	0.192	1918.9	120	0	10.5	13.5	0.202
541	0.192	1922.1	120	0	10.5	13.5	0.201
542	0.198	1925.4	120	0	10.5	13.5	0.201
543	0.21	1928.9	120	0	10.5	13.5	0.205
544	0.216	1932.5	120	0	10.5	13.5	0.201
545	0.198	1935.8	120	0	10.5	13.5	0.201
546	0.186	1938.9	120	0	10.5	13.5	0.2
547	0.198	1942.2	120	0	10.5	13.5	0.201
548	0.198	1945.5	120	0	10.5	13.5	0.201
549	0.24	1949.5	120	0	10.5	13.5	0.206
550	0.186	1952.6	120	0	10.5	13.5	0.201
551	0.192	1955.8	120	0	10.5	13.5	0.2

552	0.198	1959.1	120	0	10.5	13.5	0.202
553	0.192	1962.3	120	0	10.5	13.5	0.201
554	0.222	1966	120	0	10.5	13.5	0.205
555	0.21	1969.5	120	0	10.5	13.5	0.2
556	0.198	1972.8	120	0	10.5	13.5	0.202
557	0.192	1976	120	0	10.5	13.5	0.202
558	0.198	1979.3	120	0	10.5	13.5	0.202
559	0.21	1982.8	120	0	10.5	13.5	0.205
560	0.222	1986.5	120	0	10.5	13.5	0.205
561	0.192	1989.7	120	0	10.5	13.5	0.202
562	0.192	1992.9	120	0	10.5	13.5	0.201
563	0.198	1996.2	120	0	10.5	13.5	0.202
564	0.192	1999.4	120	0	10.5	13.5	0.201
565	0.21	2002.9	120	0	10.5	13.5	0.201
566	0.222	2006.6	120	0	10.5	13.5	0.201
567	0.192	2009.8	120	0	10.5	13.5	0.201
568	0.192	2013	120	0	10.5	13.5	0.201
569	0.198	2016.3	120	0	10.5	13.5	0.201
570	0.216	2019.9	120	0	10.5	13.5	0.205
571	0.21	2023.4	120	0	10.5	13.5	0.205
572	0.198	2026.7	120	0	10.5	13.5	0.201
573	0.198	2030	120	0	10.5	13.5	0.202
574	0.192	2033.2	120	0	10.5	13.5	0.202
575	0.216	2036.8	120	0	10.5	13.5	0.205
576	0.216	2040.4	120	0	10.5	13.5	0.205
577	0.198	2043.7	120	0	10.5	13.5	0.203
578	0.192	2046.9	120	0	10.5	13.5	0.202
579	0.192	2050.1	120	0	10.5	13.5	0.201
580	0.216	2053.7	120	0	10.5	13.5	0.205
581	0.198	2057	120	0	10.5	13.5	0.202
582	0.216	2060.6	120	0	10.5	13.5	0.202
583	0.186	2063.7	120	0	10.5	13.5	0.2
584	0.198	2067	120	0	10.5	13.5	0.201
585	0.198	2070.3	120	0	10.5	13.5	0.202
586	0.21	2073.8	120	0	10.5	13.5	0.201
587	0.216	2077.4	120	0	10.5	13.5	0.204
588	0.198	2080.7	120	0	10.5	13.5	0.201
589	0.192	2083.9	120	0	10.5	13.5	0.202
590	0.192	2087.1	120	0	10.5	13.5	0.201
591	0.222	2090.8	120	0	10.5	13.5	0.205
592	0.198	2094.1	120	0	10.5	13.5	0.203
593	0.21	2097.6	120	0	10.5	13.5	0.202
594	0.192	2100.8	120	0	10.5	13.5	0.201
595	0.198	2104.1	120	0	10.5	13.5	0.202
596	0.216	2107.7	120	0	10.5	13.5	0.206
597	0.192	2110.9	120	0	10.5	13.5	0.201
598	0.216	2114.5	120	0	10.5	13.5	0.204
599	0.192	2117.7	120	0	10.5	13.5	0.201
600	0.198	2121	120	0	10.5	13.5	0.202
601	0.21	2124.5	120	0	10.5	13.5	0.204
602	0.198	2127.8	120	0	10.5	13.5	0.201
603	0.216	2131.4	120	0	10.5	13.5	0.205
604	0.192	2134.6	120	0	10.5	13.5	0.201
605	0.192	2137.8	120	0	10.5	13.5	0.201
606	0.198	2141.1	120	0	10.5	13.5	0.201
607	0.222	2144.8	120	0	10.5	13.5	0.203

608	0.186	2147.9	120	0	10.5	13.5	0.201
609	0.222	2151.6	120	0	10.5	13.5	0.202
610	0.192	2154.8	120	0	10.5	13.5	0.202
611	0.192	2158	120	0	10.5	13.5	0.202
612	0.216	2161.6	120	0	10.5	13.5	0.205
613	0.198	2164.9	120	0	10.5	13.5	0.201
614	0.21	2168.4	120	0	10.5	13.5	0.205
615	0.192	2171.6	120	0	10.5	13.5	0.2
616	0.198	2174.9	120	0	10.5	13.5	0.201
617	0.216	2178.5	120	0	10.5	13.5	0.205
618	0.192	2181.7	120	0	10.5	13.5	0.201
619	0.198	2185	120	0	10.5	13.5	0.201
620	0.216	2188.6	120	0	10.5	13.5	0.202
621	0.198	2191.9	120	0	10.5	13.5	0.203
622	0.186	2195	120	0	10.5	13.5	0.201
623	0.222	2198.7	120	0	10.5	13.5	0.202
624	0.192	2201.9	120	0	10.5	13.5	0.202
625	0.21	2205.4	120	0	10.5	13.5	0.204
626	0.198	2208.7	120	0	10.5	13.5	0.201
627	0.198	2212	120	0	10.5	13.5	0.201
628	0.21	2215.5	120	0	10.5	13.5	0.205
629	0.192	2218.7	120	0	10.5	13.5	0.2
630	0.222	2222.4	120	0	10.5	13.5	0.205
631	0.192	2225.6	120	0	10.5	13.5	0.202
632	0.186	2228.7	120	0	10.5	13.5	0.2
633	0.222	2232.4	120	0	10.5	13.5	0.204
634	0.198	2235.7	120	0	10.5	13.5	0.202
635	0.186	2238.8	120	0	10.5	13.5	0.201
636	0.216	2242.4	120	0	10.5	13.5	0.2
637	0.198	2245.7	120	0	10.5	13.5	0.201
638	0.192	2248.9	120	0	10.5	13.5	0.202
639	0.21	2252.4	120	0	10.5	13.5	0.2
640	0.192	2255.6	120	0	10.5	13.5	0.199
641	0.222	2259.3	120	0	12	13.5	0.205
642	0.186	2262.4	120	0	12	13.5	0.2
643	0.192	2265.6	120	0	12	13.5	0.199
644	0.222	2269.3	120	0	12	13.5	0.204
645	0.192	2272.5	120	0	12	13.5	0.201
646	0.192	2275.7	120	0	12	13.5	0.201
647	0.216	2279.3	120	0	12	13.5	0.2
648	0.186	2282.4	120	0	12	14	0.2
649	0.222	2286.1	120	0	12	14	0.205
650	0.192	2289.3	120	0	12	14	0.2
651	0.192	2292.5	120	0	12	14	0.2
652	0.216	2296.1	120	0	12	14	0.204
653	0.192	2299.3	120	0	12	14	0.2
654	0.21	2302.8	120	0	12	14	0.204
655	0.198	2306.1	120	0	12	14	0.2
656	0.192	2309.3	120	0	12	14	0.2
657	0.21	2312.8	120	0	12	14	0.203
658	0.198	2316.1	120	0	12	14	0.2
659	0.192	2319.3	120	0	12	14	0.2
660	0.21	2322.8	120	0	12	14	0.2
661	0.198	2326.1	120	0	12	14	0.2
662	0.198	2329.4	120	0	12	14	0.201
663	0.21	2332.9	120	0	12	14	0.201

664	0.192	2336.1	120	0	12	14	0.2
665	0.21	2339.6	120	120	12	14	0.203
666	0.198	2342.9	120	120	12	14	0.201
667	0.192	2346.1	120	120	24	14	0.2
668	0.21	2349.6	120	120	24	14	0.202
669	0.198	2352.9	120	0	24	14	0.2
670	0.21	2356.4	120	0	24	14	0.203
671	0.198	2359.7	120	0	24	14	0.201
672	0.192	2362.9	120	0	24	14	0.2
673	0.192	2366.1	120	0	24	14	0.2
674	0.216	2369.7	120	0	24	14	0.201
675	0.192	2372.9	120	0	24	14	0.2
676	0.216	2376.5	120	0	24	14	0.201
677	0.192	2379.7	120	0	24	14	0.2
678	0.192	2382.9	120	0	24	19	0.2
679	0.216	2386.5	120	0	24	19	0.204
680	0.192	2389.7	120	0	24	19	0.2
681	0.216	2393.3	120	0	24	19	0.204
682	0.192	2396.5	120	0	24	19	0.2
683	0.192	2399.7	120	0	24	19	0.2
684	0.216	2403.3	120	0	24	19	0.204
685	0.192	2406.5	120	0	24	19	0.2
686	0.216	2410.1	120	0	30	19	0.204
687	0.192	2413.3	120	0	30	19	0.2
688	0.198	2416.6	120	0	30	19	0.201
689	0.192	2419.8	120	0	30	19	0.201
690	0.21	2423.3	120	0	30	19	0.2
691	0.198	2426.6	120	0	30	19	0.201
692	0.216	2430.2	120	0	30	19	0.201
693	0.192	2433.4	120	0	30	24	0.201
694	0.192	2436.6	120	0	30	24	0.2
695	0.222	2440.3	120	0	30	24	0.205
696	0.192	2443.5	120	0	30	24	0.202
697	0.216	2447.1	120	0	30	24	0.205
698	0.192	2450.3	120	0	30	24	0.201
699	0.192	2453.5	120	0	30	24	0.201
700	0.198	2456.8	120	0	30	24	0.202
701	0.216	2460.4	120	0	30	24	0.201
702	0.216	2464	120	0	30	24	0.205
703	0.186	2467.1	120	0	30	24	0.2
704	0.198	2470.4	120	0	30	24	0.201
705	0.198	2473.7	120	0	30	24	0.202
706	0.216	2477.3	120	0	30	24	0.205
707	0.216	2480.9	120	0	30	24	0.205
708	0.198	2484.2	120	0	30	24	0.202
709	0.186	2487.3	120	0	30	27	0.202
710	0.198	2490.6	120	0	30	27	0.202
711	0.192	2493.8	120	0	30	27	0.201
712	0.216	2497.4	120	0	30	27	0.201
713	0.216	2501	120	0	30	27	0.201
714	0.198	2504.3	120	0	30	27	0.201
715	0.192	2507.5	120	0	30	27	0.202
716	0.198	2510.8	120	0	30	27	0.202
717	0.21	2514.3	120	0	30	27	0.205
718	0.222	2518	120	0	30	27	0.206
719	0.192	2521.2	120	0	30	27	0.202

720	0.198	2524.5	120	0	40	27	0.202
721	0.192	2527.7	120	0	40	27	0.202
722	0.216	2531.3	120	0	40	27	0.205
723	0.222	2535	120	0	40	27	0.207
724	0.192	2538.2	120	0	40	27	0.202
725	0.198	2541.5	120	0	40	30	0.203
726	0.198	2544.8	120	0	40	30	0.203
727	0.186	2547.9	120	0	40	30	0.202
728	0.222	2551.6	120	0	40	30	0.203
729	0.216	2555.2	120	0	40	30	0.202
730	0.192	2558.4	120	0	40	30	0.202
731	0.198	2561.7	120	0	40	30	0.202
732	0.198	2565	120	0	40	30	0.202
733	0.216	2568.6	120	0	40	30	0.207
734	0.216	2572.2	120	0	40	30	0.206
735	0.198	2575.5	120	0	40	30	0.203
736	0.186	2578.6	120	0	40	30	0.202
737	0.198	2581.9	120	0	40	30	0.202
738	0.198	2585.2	120	0	40	30	0.202
739	0.24	2589.2	120	0	40	30	0.206
740	0.198	2592.5	120	0	40	30	0.203
741	0.192	2595.7	120	0	40	30	0.202
742	0.192	2598.9	120	0	40	30	0.203
743	0.204	2602.3	120	0	40	30	0.204
744	0.24	2606.3	120	0	40	30	0.211
745	0.186	2609.4	120	0	40	30	0.202
746	0.198	2612.7	120	0	40	30	0.202
747	0.192	2615.9	120	0	40	30	0.202
748	0.198	2619.2	120	0	45	30	0.203
749	0.222	2622.9	120	0	45	30	0.206
750	0.222	2626.6	120	0	45	30	0.203
751	0.198	2629.9	120	0	45	30	0.205
752	0.186	2633	120	0	45	30	0.203
753	0.204	2636.4	120	0	45	30	0.205
754	0.198	2639.7	120	0	45	35	0.205
755	0.228	2643.5	120	0	45	35	0.206
756	0.192	2646.7	120	0	45	35	0.201
757	0.198	2650	120	0	45	35	0.201
758	0.198	2653.3	120	0	45	35	0.203
759	0.198	2656.6	120	0	45	35	0.202
760	0.24	2660.6	120	0	45	35	0.209
761	0.192	2663.8	120	0	45	35	0.203
762	0.198	2667.1	120	0	45	35	0.204
763	0.192	2670.3	120	0	45	35	0.203
764	0.198	2673.6	120	0	45	35	0.203
765	0.198	2676.9	120	0	45	35	0.203
766	0.234	2680.8	120	0	45	35	0.202
767	0.192	2684	120	0	45	35	0.202
768	0.204	2687.4	120	0	45	35	0.203
769	0.198	2690.7	120	0	45	35	0.204
770	0.192	2693.9	120	0	45	35	0.203
771	0.24	2697.9	120	0	45	35	0.21
772	0.192	2701.1	120	0	45	35	0.203
773	0.198	2704.4	120	0	45	35	0.204
774	0.204	2707.8	120	0	45	35	0.204
775	0.192	2711	120	0	45	35	0.203

776	0.246	2715.1	120	0	45	35	0.212
777	0.192	2718.3	120	0	45	35	0.204
778	0.192	2721.5	120	0	45	35	0.204
779	0.198	2724.8	120	0	45	35	0.204
780	0.198	2728.1	120	0	45	35	0.203
781	0.198	2731.4	120	0	45	35	0.204
782	0.24	2735.4	120	0	45	35	0.203
783	0.198	2738.7	120	0	45	35	0.204
784	0.192	2741.9	120	0	45	35	0.204
785	0.198	2745.2	120	0	45	35	0.204
786	0.198	2748.5	120	0	45	35	0.204
787	0.24	2752.5	120	0	45	35	0.211
788	0.192	2755.7	120	0	45	35	0.203
789	0.198	2759	120	0	45	35	0.203
790	0.198	2762.3	120	0	45	35	0.204
791	0.198	2765.6	120	0	45	35	0.204
792	0.234	2769.5	120	0	45	35	0.21
793	0.204	2772.9	120	0	45	35	0.204
794	0.192	2776.1	120	0	45	35	0.204
795	0.198	2779.4	120	0	45	35	0.204
796	0.192	2782.6	120	0	45	35	0.203
797	0.246	2786.7	120	0	50	35	0.211
798	0.204	2790.1	120	0	50	35	0.206
799	0.198	2793.4	120	0	50	35	0.205
800	0.192	2796.6	120	0	50	35	0.205
801	0.204	2800	120	0	50	35	0.206
802	0.192	2803.2	120	0	50	35	0.206
803	0.234	2807.1	120	0	50	35	0.204
804	0.198	2810.4	120	0	50	40	0.203
805	0.198	2813.7	120	0	50	40	0.203
806	0.198	2817	120	0	50	40	0.204
807	0.198	2820.3	120	0	50	40	0.203
808	0.24	2824.3	120	0	50	40	0.211
809	0.198	2827.6	120	0	50	40	0.205
810	0.198	2830.9	120	0	50	40	0.205
811	0.198	2834.2	120	0	50	40	0.205
812	0.204	2837.6	120	0	50	40	0.206
813	0.228	2841.4	120	0	50	40	0.211
814	0.198	2844.7	120	0	50	40	0.204
815	0.204	2848.1	120	0	50	40	0.205
816	0.198	2851.4	120	0	50	40	0.205
817	0.198	2854.7	120	0	50	40	0.205
818	0.198	2858	120	0	50	40	0.204
819	0.234	2861.9	120	0	50	40	0.205
820	0.204	2865.3	120	0	50	40	0.206
821	0.198	2868.6	120	0	50	40	0.205
822	0.192	2871.8	120	0	50	40	0.204
823	0.198	2875.1	120	0	50	40	0.204
824	0.246	2879.2	120	0	50	40	0.212
825	0.198	2882.5	120	0	50	40	0.206
826	0.198	2885.8	120	0	50	40	0.205
827	0.198	2889.1	120	0	50	40	0.205
828	0.198	2892.4	120	0	50	40	0.206
829	0.216	2896	120	0	50	40	0.209
830	0.222	2899.7	120	0	50	40	0.205
831	0.198	2903	120	0	50	40	0.205

832	0.198	2906.3	120	0	50	40	0.205
833	0.198	2909.6	120	0	50	40	0.205
834	0.198	2912.9	120	0	50	40	0.205
835	0.246	2917	120	0	50	40	0.21
836	0.192	2920.2	120	0	50	40	0.205
837	0.198	2923.5	120	0	50	40	0.205
838	0.198	2926.8	120	0	50	40	0.205
839	0.198	2930.1	120	0	50	40	0.205
840	0.24	2934.1	120	0	50	40	0.212
841	0.198	2937.4	120	0	50	40	0.204
842	0.198	2940.7	120	0	50	40	0.205
843	0.198	2944	120	0	50	40	0.205
844	0.192	2947.2	120	0	50	40	0.204
845	0.228	2951	120	0	50	40	0.209
846	0.216	2954.6	120	0	50	40	0.205
847	0.198	2957.9	120	0	50	40	0.205
848	0.198	2961.2	120	0	50	40	0.205
849	0.204	2964.6	120	0	50	40	0.206
850	0.216	2968.2	120	0	52	40	0.21
851	0.216	2971.8	120	0	52	40	0.208
852	0.204	2975.2	120	0	52	40	0.206
853	0.192	2978.4	120	0	52	40	0.205
854	0.204	2981.8	120	0	52	40	0.206
855	0.198	2985.1	120	0	52	40	0.205
856	0.222	2988.8	120	0	52	40	0.206
857	0.222	2992.5	120	0	52	40	0.207
858	0.198	2995.8	120	0	52	40	0.206
859	0.198	2999.1	120	0	52	44	0.207
860	0.192	3002.3	120	0	52	44	0.205
861	0.222	3006	120	0	52	44	0.209
862	0.228	3009.8	120	0	52	44	0.21
863	0.198	3013.1	120	0	52	44	0.206
864	0.192	3016.3	120	0	52	44	0.205
865	0.198	3019.6	120	0	52	44	0.205
866	0.222	3023.3	120	0	52	44	0.21
867	0.222	3027	120	0	52	44	0.21
868	0.192	3030.2	120	0	52	44	0.204
869	0.204	3033.6	120	0	52	44	0.205
870	0.198	3036.9	120	0	52	44	0.206
871	0.198	3040.2	120	0	52	44	0.206
872	0.222	3043.9	120	0	52	44	0.206
873	0.222	3047.6	120	0	52	44	0.206
874	0.198	3050.9	120	0	52	44	0.207
875	0.198	3054.2	120	0	52	44	0.206
876	0.192	3057.4	120	0	52	44	0.205
877	0.222	3061.1	120	0	52	44	0.209
878	0.222	3064.8	120	0	52	44	0.209
879	0.198	3068.1	120	0	52	44	0.205
880	0.204	3071.5	120	0	52	44	0.206
881	0.198	3074.8	120	0	52	44	0.206
882	0.222	3078.5	120	0	52	44	0.211
883	0.198	3081.8	120	0	52	44	0.207
884	0.222	3085.5	120	0	52	44	0.207
885	0.192	3088.7	120	0	52	44	0.206
886	0.204	3092.1	120	0	52	44	0.206
887	0.216	3095.7	120	0	52	44	0.209

888	0.198	3099	120	0	52	44	0.205
889	0.228	3102.8	120	0	52	44	0.21
890	0.204	3106.2	120	0	52	44	0.207
891	0.198	3109.5	120	0	52	44	0.208
892	0.192	3112.7	120	0	52	44	0.206
893	0.222	3116.4	120	0	52	44	0.207
894	0.222	3120.1	120	0	52	44	0.211
895	0.192	3123.3	120	0	52	44	0.205
896	0.204	3126.7	120	0	52	44	0.205
897	0.204	3130.1	120	0	52	44	0.206
898	0.216	3133.7	120	0	52	44	0.21
899	0.198	3137	120	0	52	44	0.206
900	0.222	3140.7	120	0	52	44	0.206
901	0.198	3144	120	0	52	44	0.207
902	0.204	3147.4	120	0	52	44	0.207
903	0.216	3151	120	0	52	44	0.209
904	0.204	3154.4	120	0	52	44	0.207
905	0.216	3158	120	0	52	44	0.21
906	0.204	3161.4	120	0	52	44	0.207
907	0.204	3164.8	120	0	52	44	0.208
908	0.192	3168	120	0	52	44	0.206
909	0.222	3171.7	120	0	52	44	0.207
910	0.204	3175.1	120	0	52	44	0.207
911	0.216	3178.7	120	0	52	44	0.207
912	0.198	3182	120	0	52	44	0.206
913	0.204	3185.4	120	0	52	44	0.206
914	0.222	3189.1	120	0	52	44	0.211
915	0.198	3192.4	120	0	52	44	0.207
916	0.222	3196.1	120	0	52	44	0.21
917	0.198	3199.4	120	0	52	44	0.207
918	0.204	3202.8	120	0	52	44	0.208
919	0.222	3206.5	120	0	52	44	0.211
920	0.198	3209.8	120	0	52	44	0.207
921	0.222	3213.5	120	0	52	44	0.211
922	0.192	3216.7	120	0	52	44	0.206
923	0.204	3220.1	120	0	52	44	0.207
924	0.222	3223.8	120	0	52	44	0.21
925	0.198	3227.1	120	0	52	44	0.206
926	0.198	3230.4	120	0	52	44	0.206
927	0.222	3234.1	120	0	52	44	0.206
928	0.204	3237.5	120	0	52	44	0.208
929	0.198	3240.8	120	0	52	44	0.207
930	0.216	3244.4	120	0	52	44	0.206
931	0.204	3247.8	120	0	52	44	0.207
932	0.228	3251.6	120	0	53	44	0.212
933	0.192	3254.8	120	0	53	44	0.207
934	0.204	3258.2	120	0	53	44	0.207
935	0.216	3261.8	120	0	53	44	0.21
936	0.204	3265.2	120	0	53	44	0.208
937	0.204	3268.6	120	0	53	44	0.208
938	0.216	3272.2	120	0	53	44	0.206
939	0.198	3275.5	120	0	53	44	0.207
940	0.222	3279.2	120	0	53	44	0.21
941	0.204	3282.6	120	0	53	48	0.208
942	0.198	3285.9	120	0	53	48	0.207
943	0.222	3289.6	120	0	53	48	0.21

944	0.198	3292.9	120	0	53	48	0.207
945	0.222	3296.6	120	0	53	48	0.211
946	0.204	3300	120	0	53	48	0.208
947	0.198	3303.3	120	0	53	48	0.207
948	0.222	3307	120	0	53	48	0.211
949	0.198	3310.3	120	0	53	48	0.207
950	0.204	3313.7	120	0	53	48	0.208
951	0.222	3317.4	120	0	53	48	0.208
952	0.198	3320.7	120	0	53	48	0.207
953	0.192	3323.9	120	0	53	48	0.206
954	0.228	3327.7	120	0	53	48	0.207
955	0.198	3331	120	0	53	48	0.207
956	0.222	3334.7	120	0	53	48	0.21
957	0.204	3338.1	120	0	53	48	0.207
958	0.204	3341.5	120	0	53	48	0.208
959	0.216	3345.1	120	0	53	48	0.212
960	0.204	3348.5	120	0	53	48	0.208
961	0.222	3352.2	120	0	53	48	0.212
962	0.198	3355.5	120	0	53	48	0.208
963	0.204	3358.9	120	0	53	48	0.208
964	0.198	3362.2	120	0	53	48	0.207
965	0.222	3365.9	120	0	53	48	0.208
966	0.204	3369.3	120	0	53	48	0.208
967	0.222	3373	120	0	53	48	0.208
968	0.192	3376.2	120	0	53	48	0.207
969	0.198	3379.5	120	0	53	48	0.206
970	0.228	3383.3	120	0	53	48	0.211
971	0.204	3386.7	120	0	53	48	0.208
972	0.222	3390.4	120	0	53	48	0.211
973	0.192	3393.6	120	0	53	48	0.206
974	0.204	3397	120	0	53	48	0.208
975	0.228	3400.8	120	0	53	48	0.213
976	0.204	3404.2	120	0	53	48	0.209
977	0.216	3407.8	120	0	53	48	0.211
978	0.198	3411.1	120	0	53	48	0.207
979	0.198	3414.4	120	0	53	48	0.208
980	0.204	3417.8	120	0	53	48	0.208
981	0.222	3421.5	120	0	53	48	0.207
982	0.204	3424.9	120	0	53	48	0.207
983	0.222	3428.6	120	0	53	48	0.208
984	0.198	3431.9	120	0	53	48	0.208
985	0.192	3435.1	120	0	53	48	0.207
986	0.228	3438.9	120	0	53	48	0.211
987	0.204	3442.3	120	0	53	48	0.208
988	0.216	3445.9	120	0	53	48	0.21
989	0.204	3449.3	120	0	53	48	0.207
990	0.204	3452.7	120	0	53	48	0.208
991	0.198	3456	120	0	53	48	0.209
992	0.222	3459.7	120	120	53	48	0.208
993	0.222	3463.4	120	120	53	48	0.211
994	0.204	3466.8	120	120	53	50	0.209
995	0.198	3470.1	120	120	53	50	0.208
996	0.204	3473.5	120	0	53	50	0.208
997	0.216	3477.1	120	0	53	50	0.211
998	0.204	3480.5	120	0	53	50	0.208
999	0.228	3484.3	120	0	53	50	0.209

1000	0.204	3487.7	120	0	53	50	0.209
1001	0.198	3491	120	0	53	50	0.209
1002	0.216	3494.6	120	0	53	50	0.211
1003	0.204	3498	120	0	53	50	0.209
1004	0.216	3501.6	120	0	53	50	0.211
1005	0.204	3505	120	0	53	50	0.207
1006	0.198	3508.3	120	0	53	50	0.206
1007	0.198	3511.6	120	0	53	50	0.206
1008	0.228	3515.4	120	0	53	50	0.208
1009	0.222	3519.1	120	0	53	50	0.211
1010	0.198	3522.4	120	0	53	50	0.208
1011	0.204	3525.8	120	0	53	50	0.208
1012	0.204	3529.2	120	0	53	50	0.209
1013	0.222	3532.9	120	0	53	50	0.213
1014	0.216	3536.5	120	0	53	50	0.211
1015	0.204	3539.9	120	0	53	50	0.208
1016	0.21	3543.4	120	0	53	50	0.21
1017	0.192	3546.6	120	0	53	50	0.208
1018	0.198	3549.9	120	0	53	50	0.207
1019	0.228	3553.7	120	0	53	50	0.208
1020	0.216	3557.3	120	0	53	50	0.208
1021	0.21	3560.8	120	0	53	50	0.209
1022	0.198	3564.1	120	0	53	50	0.207
1023	0.198	3567.4	120	0	53	50	0.208
1024	0.228	3571.2	120	0	53	50	0.213
1025	0.216	3574.8	120	0	53	50	0.211
1026	0.204	3578.2	120	0	53	50	0.209
1027	0.204	3581.6	120	0	53	50	0.208
1028	0.198	3584.9	120	0	53	50	0.208
1029	0.198	3588.2	120	0	53	50	0.208
1030	0.246	3592.3	120	0	53	50	0.211
1031	0.204	3595.7	120	0	53	50	0.209
1032	0.204	3599.1	120	0	53	50	0.209
1033	0.204	3602.5	120	0	53	50	0.209
1034	0.198	3605.8	120	0	53	50	0.209
1035	0.216	3609.4	120	0	53	50	0.212
1036	0.228	3613.2	120	0	53	50	0.209
1037	0.198	3616.5	120	0	53	50	0.208
1038	0.204	3619.9	120	0	53	50	0.208
1039	0.204	3623.3	120	0	53	50	0.208
1040	0.222	3627	120	0	53	50	0.212
1041	0.222	3630.7	120	0	53	50	0.213
1042	0.198	3634	120	0	53	50	0.208
1043	0.198	3637.3	120	0	53	50	0.208
1044	0.204	3640.7	120	0	53	50	0.208
1045	0.204	3644.1	120	0	53	50	0.208
1046	0.246	3648.2	120	0	53	50	0.212
1047	0.204	3651.6	120	0	53	50	0.209
1048	0.192	3654.8	120	0	53	50	0.208
1049	0.198	3658.1	120	0	53	50	0.208
1050	0.204	3661.5	120	0	53	50	0.208
1051	0.246	3665.6	120	0	53	50	0.215
1052	0.204	3669	120	0	53	50	0.208
1053	0.204	3672.4	120	0	53	50	0.208
1054	0.204	3675.8	120	0	53	50	0.21
1055	0.198	3679.1	120	0	53	50	0.21

1056	0.198	3682.4	120	0	53	50	0.209
1057	0.246	3686.5	120	0	53	50	0.209
1058	0.198	3689.8	120	0	53	50	0.208
1059	0.21	3693.3	120	0	53	50	0.209
1060	0.192	3696.5	120	0	53	50	0.207
1061	0.204	3699.9	120	0	53	50	0.208
1062	0.252	3704.1	120	0	53	50	0.217
1063	0.192	3707.3	120	0	53	50	0.208
1064	0.204	3710.7	120	0	53	50	0.209
1065	0.198	3714	120	0	53	50	0.207
1066	0.204	3717.4	120	0	53	50	0.209
1067	0.246	3721.5	120	0	53	50	0.216
1068	0.204	3724.9	120	0	53	50	0.208
1069	0.192	3728.1	120	0	53	50	0.208
1070	0.204	3731.5	120	0	53	50	0.208
1071	0.204	3734.9	120	0	53	50	0.209
1072	0.198	3738.2	120	0	53	50	0.208
1073	0.246	3742.3	120	0	53	50	0.208
1074	0.198	3745.6	120	0	53	50	0.207
1075	0.204	3749	120	0	53	50	0.209
1076	0.204	3752.4	120	0	53	50	0.209
1077	0.204	3755.8	120	0	53	50	0.209
1078	0.246	3759.9	120	0	53	50	0.217
1079	0.198	3763.2	120	0	53	50	0.209
1080	0.198	3766.5	120	0	53	50	0.209
1081	0.198	3769.8	120	0	53	50	0.208
1082	0.204	3773.2	120	0	53	51.6	0.208
1083	0.246	3777.3	120	0	53	51.6	0.215
1084	0.198	3780.6	120	0	53	51.6	0.207
1085	0.204	3784	120	0	53	51.6	0.208
1086	0.204	3787.4	120	0	53	51.6	0.209
1087	0.204	3790.8	120	0	53	51.6	0.21
1088	0.246	3794.9	120	0	53	51.6	0.217
1089	0.204	3798.3	120	0	54	51.6	0.21
1090	0.198	3801.6	120	0	54	51.6	0.21
1091	0.204	3805	120	0	54	51.6	0.21
1092	0.198	3808.3	120	0	54	51.6	0.209
1093	0.204	3811.7	120	0	54	51.6	0.209
1094	0.246	3815.8	120	0	54	51.6	0.209
1095	0.192	3819	120	0	54	51.6	0.207
1096	0.204	3822.4	120	0	54	51.6	0.208
1097	0.204	3825.8	120	0	54	51.6	0.208
1098	0.198	3829.1	120	0	54	51.6	0.208
1099	0.24	3833.1	120	0	54	52	0.214
1100	0.204	3836.5	120	0	54	52	0.207
1101	0.198	3839.8	120	0	54	52	0.208
1102	0.204	3843.2	120	0	54	52	0.208
1103	0.21	3846.7	120	0	54	52	0.209
1104	0.246	3850.8	120	0	54	52	0.217
1105	0.198	3854.1	120	0	54	52	0.21
1106	0.204	3857.5	120	0	54	52	0.21
1107	0.204	3860.9	120	0	54	52	0.211
1108	0.198	3864.2	120	0	54	52	0.21
1109	0.198	3867.5	120	0	54	52	0.208
1110	0.246	3871.6	120	0	54	52	0.208
1111	0.204	3875	120	0	54	52	0.209

1112	0.198	3878.3	120	0	54	52	0.208
1113	0.198	3881.6	120	0	54	52	0.207
1114	0.198	3884.9	120	0	54	52	0.207
1115	0.252	3889.1	120	0	54	52	0.216
1116	0.204	3892.5	120	0	54	52	0.209
1117	0.198	3895.8	120	0	54	52	0.208
1118	0.204	3899.2	120	0	54	52	0.209
1119	0.198	3902.5	120	0	54	52	0.209
1120	0.222	3906.2	120	0	54	52	0.213
1121	0.228	3910	120	0	54	52	0.209
1122	0.204	3913.4	120	0	54	52	0.209
1123	0.198	3916.7	120	0	54	52	0.209
1124	0.198	3920	120	0	54	52	0.208
1125	0.204	3923.4	120	0	54	52	0.209
1126	0.246	3927.5	120	0	54	52	0.213
1127	0.204	3930.9	120	0	54	52	0.209
1128	0.204	3934.3	120	0	54	52	0.209
1129	0.198	3937.6	120	0	54	52	0.209
1130	0.198	3940.9	120	0	54	52	0.209
1131	0.246	3945	120	0	54	52	0.216
1132	0.204	3948.4	120	0	54	52	0.209
1133	0.204	3951.8	120	0	54	52	0.209
1134	0.198	3955.1	120	0	54	52	0.208
1135	0.204	3958.5	120	0	54	52	0.209
1136	0.228	3962.3	120	0	54	52	0.214
1137	0.216	3965.9	120	0	54	52	0.209
1138	0.204	3969.3	120	0	54	52	0.209
1139	0.204	3972.7	120	0	54	52	0.209
1140	0.198	3976	120	0	54	52	0.209
1141	0.216	3979.6	120	0	54	52	0.211
1142	0.228	3983.4	120	0	54	52	0.211
1143	0.204	3986.8	120	0	54	52	0.209
1144	0.204	3990.2	120	0	54	52	0.209
1145	0.192	3993.4	120	0	54	52	0.207
1146	0.204	3996.8	120	0	54	52	0.208
1147	0.228	4000.6	120	0	54	52	0.21
1148	0.222	4004.3	120	0	54	52	0.209
1149	0.198	4007.6	120	0	54	52	0.208
1150	0.204	4011	120	0	54	52	0.208
1151	0.204	4014.4	120	0	54	52	0.21
1152	0.222	4018.1	120	0	54	52	0.213
1153	0.222	4021.8	120	0	54	52	0.212
1154	0.198	4025.1	120	0	54	52	0.208
1155	0.204	4028.5	120	0	54	52	0.209
1156	0.204	4031.9	120	0	54	52	0.209
1157	0.222	4035.6	120	0	54	52	0.212
1158	0.222	4039.3	120	0	54	52	0.212
1159	0.204	4042.7	120	0	54	52	0.209
1160	0.204	4046.1	120	0	54	52	0.21
1161	0.204	4049.5	120	0	54	52	0.21
1162	0.204	4052.9	120	0	54	52	0.21
1163	0.222	4056.6	120	0	54	52	0.21
1164	0.216	4060.2	120	0	54	52	0.209
1165	0.204	4063.6	120	0	54	52	0.209
1166	0.198	4066.9	120	0	54	52	0.208
1167	0.21	4070.4	120	0	54	52	0.209

1168	0.216	4074	120	0	54	52	0.211
1169	0.228	4077.8	120	0	54	52	0.212
1170	0.198	4081.1	120	0	54	52	0.209
1171	0.198	4084.4	120	0	54	52	0.208
1172	0.204	4087.8	120	0	54	52	0.209
1173	0.222	4091.5	120	0	54	52	0.211
1174	0.204	4094.9	120	0	54	52	0.209
1175	0.228	4098.7	120	0	54	52	0.209
1176	0.192	4101.9	120	0	54	52	0.208
1177	0.204	4105.3	120	0	54	52	0.209
1178	0.228	4109.1	120	0	54	52	0.213
1179	0.204	4112.5	120	0	54	52	0.21
1180	0.222	4116.2	120	0	54	52	0.213
1181	0.198	4119.5	120	0	54	52	0.208
1182	0.204	4122.9	120	0	54	52	0.21
1183	0.198	4126.2	120	0	54	52	0.209
1184	0.222	4129.9	120	0	54	52	0.208
1185	0.228	4133.7	120	0	54	52	0.212
1186	0.204	4137.1	120	0	54	52	0.209
1187	0.192	4140.3	120	0	54	52	0.208
1188	0.21	4143.8	120	0	54	52	0.209
1189	0.228	4147.6	120	0	54	52	0.214
1190	0.192	4150.8	120	0	54	52	0.209
1191	0.228	4154.6	120	0	54	52	0.209
1192	0.198	4157.9	120	0	54	52	0.208
1193	0.21	4161.4	120	0	54	52	0.211
1194	0.216	4165	120	0	54	52	0.212
1195	0.204	4168.4	120	0	54	52	0.208
1196	0.216	4172	120	0	54	52	0.212
1197	0.204	4175.4	120	0	54	52	0.208
1198	0.21	4178.9	120	0	54	52	0.21
1199	0.198	4182.2	120	0	54	52	0.208
1200	0.228	4186	120	0	54	52	0.21
1201	0.204	4189.4	120	0	54	52	0.21
1202	0.216	4193	120	0	54	52	0.21
1203	0.204	4196.4	120	0	54	52	0.21
1204	0.198	4199.7	120	0	54	52	0.208
1205	0.222	4203.4	120	0	54	52	0.212
1206	0.204	4206.8	120	0	54	52	0.208
1207	0.228	4210.6	120	0	54	52	0.212
1208	0.198	4213.9	120	0	54	52	0.209
1209	0.204	4217.3	120	0	54	52	0.209
1210	0.222	4221	120	0	54	52	0.213
1211	0.198	4224.3	120	0	54	52	0.209
1212	0.228	4228.1	120	0	54	52	0.213
1213	0.204	4231.5	120	0	54	52	0.209
1214	0.198	4234.8	120	0	54	52	0.209
1215	0.204	4238.2	120	0	54	52	0.209
1216	0.222	4241.9	120	0	54	52	0.209
1217	0.204	4245.3	120	0	54	52	0.21
1218	0.222	4249	120	0	54	52	0.209
1219	0.204	4252.4	120	0	54	52	0.209
1220	0.198	4255.7	120	0	54	52	0.209
1221	0.222	4259.4	120	0	54	52	0.212
1222	0.21	4262.9	120	0	54	52	0.21
1223	0.222	4266.6	120	0	54	52	0.213

1224	0.198	4269.9	120	0	54	52	0.209
1225	0.204	4273.3	120	0	54	52	0.209
1226	0.222	4277	120	0	54	52	0.213
1227	0.204	4280.4	120	0	54	52	0.21
1228	0.198	4283.7	120	0	54	52	0.208
1229	0.228	4287.5	120	0	54	52	0.209
1230	0.204	4290.9	120	0	54	52	0.21
1231	0.228	4294.7	120	0	54	52	0.214
1232	0.198	4298	120	0	54	52	0.21
1233	0.198	4301.3	120	0	54	52	0.209
1234	0.222	4305	120	0	54	52	0.213
1235	0.198	4308.3	120	0	54	52	0.208
1236	0.204	4311.7	120	0	54	52	0.208
1237	0.228	4315.5	120	0	54	52	0.208
1238	0.198	4318.8	120	0	54	52	0.208
1239	0.228	4322.6	120	0	54	52	0.213
1240	0.198	4325.9	120	0	54	52	0.209
1241	0.198	4329.2	120	0	54	52	0.209
1242	0.222	4332.9	120	0	54	52	0.212
1243	0.204	4336.3	120	0	54	52	0.208
1244	0.204	4339.7	120	0	54	52	0.209
1245	0.228	4343.5	120	0	54	52	0.209
1246	0.204	4346.9	120	0	54	52	0.21
1247	0.216	4350.5	120	0	54	52	0.213
1248	0.204	4353.9	120	0	54	52	0.21
1249	0.21	4357.4	120	0	54	52	0.211
1250	0.216	4361	120	0	54	52	0.213
1251	0.204	4364.4	120	0	54	52	0.209
1252	0.222	4368.1	120	0	54	52	0.212
1253	0.198	4371.4	120	0	54	52	0.209
1254	0.204	4374.8	120	0	54	52	0.209
1255	0.204	4378.2	120	0	54	52	0.208
1256	0.222	4381.9	120	0	54	52	0.209
1257	0.204	4385.3	120	0	54	52	0.209
1258	0.228	4389.1	120	0	54	52	0.21
1259	0.204	4392.5	120	0	54	52	0.211
1260	0.198	4395.8	120	0	54	52	0.21
1261	0.228	4399.6	120	0	54	52	0.214
1262	0.198	4402.9	120	0	54	52	0.21
1263	0.222	4406.6	120	0	54	52	0.213
1264	0.204	4410	120	0	54	52	0.209
1265	0.198	4413.3	120	0	54	52	0.208
1266	0.222	4417	120	0	54	52	0.212
1267	0.204	4420.4	120	0	54	52	0.208
1268	0.222	4424.1	120	0	54	52	0.212
1269	0.204	4427.5	120	0	54	52	0.209
1270	0.204	4430.9	120	0	54	52	0.209
1271	0.204	4434.3	120	0	54	52	0.21
1272	0.222	4438	120	0	54	52	0.21
1273	0.204	4441.4	120	0	54	52	0.21
1274	0.228	4445.2	120	0	54	52	0.211
1275	0.198	4448.5	120	0	54	52	0.21
1276	0.198	4451.8	120	0	54	52	0.209
1277	0.228	4455.6	120	0	54	52	0.213
1278	0.198	4458.9	120	0	54	52	0.209
1279	0.222	4462.6	120	0	54	52	0.212

1280	0.204	4466	120	0	54	52	0.208
1281	0.204	4469.4	120	0	54	52	0.209
1282	0.21	4472.9	120	0	54	52	0.211
1283	0.222	4476.6	120	0	54	52	0.21
1284	0.222	4480.3	120	0	54	52	0.214
1285	0.204	4483.7	120	0	54	52	0.211
1286	0.198	4487	120	0	54	52	0.21
1287	0.204	4490.4	120	0	54	52	0.21
1288	0.222	4494.1	120	0	54	52	0.212
1289	0.21	4497.6	120	0	54	52	0.21
1290	0.216	4501.2	120	0	54	52	0.209
1291	0.204	4504.6	120	0	54	52	0.209
1292	0.198	4507.9	120	0	54	52	0.209
1293	0.228	4511.7	120	0	54	52	0.213
1294	0.204	4515.1	120	0	54	52	0.21
1295	0.222	4518.8	120	0	54	52	0.212
1296	0.204	4522.2	120	0	54	52	0.21
1297	0.21	4525.7	120	0	54	52	0.211
1298	0.198	4529	120	0	54	52	0.211
1299	0.222	4532.7	120	0	54	52	0.21
1300	0.222	4536.4	120	0	54	52	0.213
1301	0.198	4539.7	120	0	54	52	0.209
1302	0.204	4543.1	120	0	54	52	0.209
1303	0.204	4546.5	120	0	54	52	0.208
1304	0.222	4550.2	120	0	54	52	0.212
1305	0.228	4554	120	0	54	52	0.213
1306	0.198	4557.3	120	0	54	52	0.209
1307	0.204	4560.7	120	0	54	52	0.21
1308	0.204	4564.1	120	0	54	52	0.21
1309	0.204	4567.5	120	0	54	52	0.21
1310	0.222	4571.2	120	0	54	52	0.21
1311	0.222	4574.9	120	0	54	52	0.209
1312	0.204	4578.3	120	0	54	52	0.21
1313	0.204	4581.7	120	0	54	52	0.21
1314	0.204	4585.1	120	0	54	52	0.21
1315	0.222	4588.8	120	0	54	52	0.213
1316	0.222	4592.5	120	0	54	52	0.213
1317	0.198	4595.8	120	0	54	52	0.209
1318	0.204	4599.2	120	0	54	53	0.209
1319	0.198	4602.5	120	0	54	53	0.208
1320	0.204	4605.9	120	0	54	53	0.208
1321	0.252	4610.1	120	0	54	53	0.213
1322	0.204	4613.5	120	0	54	53	0.21
1323	0.198	4616.8	120	0	54	53	0.21
1324	0.204	4620.2	120	0	54	53	0.21
1325	0.204	4623.6	120	0	54	53	0.211
1326	0.222	4627.3	120	0	54	53	0.214
1327	0.222	4631	120	0	54	53	0.209
1328	0.204	4634.4	120	0	54	53	0.209
1329	0.204	4637.8	120	0	54	53	0.21
1330	0.198	4641.1	120	0	54	53	0.209
1331	0.228	4644.9	120	0	54	53	0.213
1332	0.222	4648.6	120	0	54	53	0.213
1333	0.204	4652	120	0	54	53	0.21
1334	0.198	4655.3	120	0	54	53	0.209

Appendix B

Measurements for FloWizard test 1 where temperature was increased:

Time [s]	Flowrate [L/min]	Weight [kg]	P inlet [bar]	P outlet [bar]	Temperature spring [°C]	Temperature outlet [°C]
6		0	120	0	17.4	14.9
12		0.6	120	0	17.4	14.9
18		4.9	120	0	17.4	14.9
24		61.5	120	0	17.4	14.9
30	0.984	159.9	120	0	17.4	14.9
36	1.009	260.8	120	0	17.4	14.9
42	0.996	360.4	120	0	17.4	14.9
48	1.002	460.6	120	0	17.4	14.9
54	0.997	560.3	120	0	17.4	14.9
60	0.984	658.7	120	130	17.4	16.5
66	0.983	757	120	130	17.4	16.5
72	0.989	855.9	120	0	17.4	16.5
78	0.987	954.6	120	0	17.4	16.5
84	1.02	1056.6	120	0	17.4	16.5
90	0.987	1155.3	120	0	17.4	16.5
96	0.986	1253.9	120	0	17.4	16
102	0.987	1352.6	120	0	17.4	16
108	0.978	1450.4	120	0	17.4	16
114	0.979	1548.3	120	0	17.4	16
120	0.983	1646.6	120	0	17.4	16
126	0.98	1744.6	120	0	17.4	16
132	1.018	1846.4	120	0	17.4	16
138	0.982	1944.6	120	0	17.4	16
144	0.98	2042.6	120	0	17.2	16
150	0.98	2140.6	120	0	17.2	16
156	0.981	2238.7	120	0	17.2	16
162	0.98	2336.7	120	0	17.2	16
168	0.98	2434.7	120	0	17.2	16
174	0.997	2534.4	120	0	17.2	16
180	0.98	2632.4	120	0	17.2	16
186	0.997	2732.1	120	0	17.2	16
192	0.98	2830.1	120	0	17.2	16
198	0.98	2928.1	120	0	17.2	16
204	0.98	3026.1	120	0	17.2	16
210	0.979	3124	120	0	17.2	15.7
216	0.98	3222	120	0	17.2	15.7
222	0.996	3321.6	120	0	17.2	15.7
228	0.979	3419.5	120	0	17.2	15.7
234	0.98	3517.5	120	0	17.2	15.7
240	0.996	3617.1	120	0	17.2	15.7
246	0.979	3715	120	0	17.2	15.7
252	0.979	3812.9	120	0	17.2	15.7
258	0.979	3910.8	120	0	17.2	15.7
264	0.996	4010.4	120	0	17.2	15.7

270	0.979	4108.3	120	0	17.2	15.5
276	0.979	4206.2	120	0	16.9	15.5
282	0.979	4304.1	120	0	16.9	15.5
288	0.979	4402	120	0	16.9	15.5
294	0.996	4501.6	120	0	16.9	15.5
300	0.979	4599.5	120	0	16.9	15.5
306		0	120	0	16.9	15.5
312		0	120	0	16.9	15.5
318		0	120	0	16.9	15.5
324		0	120	0	16.9	15.5
330		-448	120	0	16.9	15.5
336		-448	120	0	16.9	15.5
342		-448	120	0	16.9	15.5
348		-448	120	0	16.9	15.5
354		-448	120	0	16.9	15.5
360		-448	120	0	16.9	15.5
366		-448	120	0	16.9	15.5
372		4.7	120	0	16.9	15.5
378		4.9	120	0	16.9	15.5
384		5	120	0	16.9	15.5
390		24	120	0	16.9	15.5
396	1.022	126.2	120	0	16.9	15.5
402	0.983	224.5	120	0	16.9	15.5
408	0.976	322.1	120	0	16.9	15.5
414	1	422.1	120	0	16.9	15.5
420	1.001	522.2	120	0	16.9	15.5
426	0.996	621.8	120	0	16.9	15.5
432	0.981	719.9	120	0	16.7	16
438	0.986	818.5	120	0	16.7	16
444	1.006	919.1	120	0	16.7	16
450	1.002	1019.3	120	0	16.7	16
456	0.987	1118	120	0	16.7	16
462	0.988	1216.8	120	0	16.7	16
468	0.987	1315.5	120	0	16.7	16
474	0.989	1414.4	120	0	16.7	16
480	0.971	1511.5	120	0	16.7	16
486	0.981	1609.6	120	0	16.7	16
492	1	1709.6	120	0	16.7	15.5
498	0.983	1807.9	120	0	16.7	15.5
504	1.001	1908	120	0	16.7	15.5
510	0.982	2006.2	120	0	16.7	15.5
516	0.979	2104.1	120	0	16.7	15.5
522	0.982	2202.3	120	0	16.6	15.5
528	0.981	2300.4	120	0	16.6	15.5
534	1	2400.4	120	0	16.6	15.3
540	0.982	2498.6	120	0	16.6	15.3
546	0.98	2596.6	120	0	16.6	15.3
552	0.982	2694.8	120	0	16.6	15.3
558	0.998	2794.6	120	0	16.6	15.3
564	0.981	2892.7	120	0	16.6	15.3
570	0.981	2990.8	120	0	16.6	15.3
576	0.998	3090.6	120	0	16.6	15.3
582	0.981	3188.7	120	0	16.6	15.3
588	0.981	3286.8	120	0	16.6	15.3
594	0.98	3384.8	120	0	16.6	15.3
600	0.98	3482.8	120	0	16.6	15.3

606	0.98	3580.8	120	0	16.6	15.3
612	0.979	3678.7	120	0	16.4	15.3
618	0.998	3778.5	120	0	16.4	15.3
624	0.996	3878.1	120	0	16.4	15.3
630	0.976	3975.7	120	0	16.4	15.3
636	0.975	4073.2	120	0	16.4	15.3
642	0.973	4170.5	120	0	16.4	15.3
648	0.975	4268	120	0	16.4	15.3
654	0.98	4366	120	0	16.4	15.3
660	0.983	4464.3	120	0	16.4	15.3
666	1.019	4566.2	120	0	16.4	15.3
672		0	120	0	16.4	15.3
678		0	120	0	16.4	15.3
684		0	120	0	16.4	15.3
690		0	120	0	16.4	15.3
696		0	120	0	16.4	15.3
702		-448	120	0	16.4	15.3
708		-448	120	0	16.4	15.3
714		-448	120	0	16.4	15.3
720		-448	120	0	16.4	15.3
726		-448	120	0	16.4	15.3
732		-448	120	0	16.4	15.3
738		4.4	120	0	16.4	15.3
744		4.8	120	0	16.4	15.3
750		4.8	120	0	16.4	15.3
756		6.5	120	0	16.4	15.3
762		53.1	120	0	16.4	15.3
768	1.014	154.5	120	0	16.4	15.3
774	0.981	252.6	120	0	16.4	15.3
780	1.007	353.3	120	0	16.4	23.2
786	1.012	454.5	120	0	17.5	23.2
792	1.008	555.3	120	0	17.5	23.2
798	0.994	654.7	120	0	17.5	23.2
804	1.009	755.6	120	0	17.5	23.2
810	0.996	855.2	120	0	17.5	23.2
816	0.995	954.7	120	130	17.5	23.2
822	1.012	1055.9	120	130	17.5	24.5
828	0.996	1155.5	120	0	17.5	24.5
834	0.995	1255	120	0	17.7	24.5
840	0.996	1354.6	120	0	17.7	24.5
846	1.005	1455.1	120	0	17.7	24.5
852	0.993	1554.4	120	0	17.7	24.5
858	0.995	1653.9	120	0	17.7	24.5
864	0.993	1753.2	120	0	17.7	24.5
870	0.994	1852.6	120	0	17.9	24.5
876	1.011	1953.7	120	0	17.9	24.5
882	0.992	2052.9	120	0	17.9	25.8
888	0.991	2152	120	0	17.9	25.8
894	1.008	2252.8	120	0	17.9	25.8
900	0.99	2351.8	120	0	17.9	25.8
906	0.991	2450.9	120	0	17.9	25.8
912	0.99	2549.9	120	0	17.9	25.8
918	0.99	2648.9	120	0	17.9	25.8
924	0.991	2748	120	0	17.9	25.8
930	0.989	2846.9	120	0	17.9	26.5
936	1.025	2949.4	120	0	18.5	26.5

942	0.99	3048.4	120	0	18.5	26.5
948	0.989	3147.3	120	0	18.5	26.5
954	0.99	3246.3	120	0	18.5	27
960	0.989	3345.2	120	0	18.5	27
966	0.989	3444.1	120	0	18.7	27
972	0.989	3543	120	0	18.7	27
978	0.989	3641.9	120	0	18.7	27
984	1.023	3744.2	120	0	18.7	27
990	0.988	3843	120	0	18.7	27
996	0.989	3941.9	120	0	19	27
1002	0.988	4040.7	120	0	19	27
1008	0.989	4139.6	120	0	19	27
1014	0.987	4238.3	120	0	19	27
1020	0.987	4337	120	0	19	27
1026	1.006	4437.6	120	0	19	27
1032	1.006	4538.2	120	0	19	27
1038	0.987	4636.9	120	0	19	27
1044		0	120	0	19	27
1050		0	120	0	19	27
1056		0	120	0	19	27
1062		0	120	0	19	27
1068		146.7	120	0	19	27
1074		-448	120	0	19	27
1080		-448	120	0	19	27
1086		-448	120	0	19	27
1092		-448	120	0	19	27
1098		-447.6	120	0	19	27
1104		4.2	120	0	19	27
1110		4.8	120	0	19	27
1116		4.8	120	0	19	27
1122		4.8	120	0	19	27
1128		47.3	120	0	19	27
1134	0.997	147	120	0	19	27
1140	1.008	247.8	120	0	19	27
1146	0.984	346.2	120	0	19	27
1152	1.01	447.2	120	0	19	27
1158	1.01	548.2	120	0	19	27
1164	1.019	650.1	120	0	20	27
1170	0.988	748.9	120	0	20	27
1176	0.997	848.6	120	0	20	27
1182	0.996	948.2	120	0	20	27
1188	0.994	1047.6	120	0	20	27
1194	0.993	1146.9	120	0	20	27
1200	1.013	1248.2	120	0	20	27
1206	1.013	1349.5	120	0	20	27
1212	0.995	1449	120	0	20	27
1218	0.977	1546.7	120	0	20	27
1224	0.988	1645.5	120	0	20	27
1230	0.989	1744.4	120	0	20	27
1236	0.99	1843.4	120	0	20.5	27
1242	0.99	1942.4	120	0	20.5	27.5
1248	0.988	2041.2	120	0	20.5	27.5
1254	1.022	2143.4	120	0	20.5	27.5
1260	0.988	2242.2	120	0	20.5	27.5
1266	0.988	2341	120	0	20.5	27.5
1272	0.989	2439.9	120	0	20.5	27.5

1278	0.986	2538.5	120	0	20.5	27.5
1284	0.988	2637.3	120	0	20.5	27.5
1290	0.987	2736	120	0	20.5	27.5
1296	1.023	2838.3	120	0	20.5	27.5
1302	0.988	2937.1	120	0	20.5	27.5
1308	0.987	3035.8	120	0	20.5	27.5
1314	0.986	3134.4	120	0	20.5	27.5
1320	0.987	3233.1	120	0	20.5	27.5
1326	0.987	3331.8	120	0	21	27.5
1332	0.987	3430.5	120	0	21	27.5
1338	0.987	3529.2	120	0	21	27.5
1344	1.004	3629.6	120	0	21	17.6
1350	1.004	3730	120	0	21	17.6
1356	0.986	3828.6	120	0	21	17.6
1362	0.987	3927.3	120	0	21	17.6
1368	0.986	4025.9	120	0	21	17.6
1374	0.986	4124.5	120	0	21	17.6
1380	0.987	4223.2	120	0	21	17.6
1386	1.005	4323.7	120	0	21	17.6
1392	0.987	4422.4	120	0	21	17.6
1398	0.986	4521	120	0	21	17.6
1404	1.004	4621.4	120	0	21	17.6
1410		0	120	0	21	17.6
1416		0	120	0	21	17.6
1422		0	120	0	21	17.6
1428		0	120	0	21.5	17.6
1434		0	120	0	21.5	17.6
1440		0	120	0	21.5	17.6
1446		0	120	0	21.5	17.6
1452		0	120	0	21.5	17.6
1458		0	120	0	21.5	17.6
1464		-448	120	0	21.5	17.6
1470		-448	120	0	21.5	17.6
1476		-448	120	0	21.5	17.6
1482		-448	120	0	21.5	17.6
1488		-448	120	0	21.5	17.6
1494		-448	120	0	21.5	17.6
1500		3.6	120	0	21.5	17.6
1506		3.7	120	0	21.5	17.6
1512		3.8	120	0	21.5	17.6
1518		0	120	0	21.5	17.6
1524		22.9	120	0	21.5	17.6
1530		115.1	120	0	21.5	17.6
1536	0.99	214.1	120	0	21.5	17.6
1542	0.978	311.9	120	0	21.5	17.6
1548	1	411.9	120	0	21.5	17.6
1554	1.001	512	120	0	21.5	30
1560	0.984	610.4	120	0	21.5	30
1566	1.022	712.6	120	0	22	30
1572	0.986	811.2	120	0	22	30
1578	0.984	909.6	120	0	22	40
1584	0.986	1008.2	120	0	22	45
1590	0.987	1106.9	120	0	22	45
1596	0.987	1205.6	120	0	22	45
1602	0.979	1303.5	120	0	22	48
1608	0.978	1401.3	120	0	22	48

1614	1.017	1503	120	0	22	50
1620	0.982	1601.2	120	0	22	50
1626	0.984	1699.6	120	0	22	50
1632	0.981	1797.7	120	0	23	50
1638	0.98	1895.7	120	0	23	50
1644	0.98	1993.7	120	0	23	50
1650	0.98	2091.7	120	0	23	50
1656	0.997	2191.4	120	0	23	52
1662	0.98	2289.4	120	0	24.3	52
1668	0.997	2389.1	120	0	24.3	52
1674	0.979	2487	120	0	24.3	52
1680	0.979	2584.9	120	0	24.3	53
1686	0.98	2682.9	120	0	25	53
1692	0.978	2780.7	120	0	25	53
1698	0.978	2878.5	120	0	25	53.5
1704	0.996	2978.1	120	0	25	53.5
1710	0.979	3076	120	0	25.8	53.5
1716	0.979	3173.9	120	0	25.8	53.5
1722	0.995	3273.4	120	0	25.8	56
1728	0.979	3371.3	120	0	25.8	56
1734	0.977	3469	120	0	26.6	56
1740	0.978	3566.8	120	0	26.6	56
1746	0.996	3666.4	120	0	26.6	54
1752	0.978	3764.2	120	0	26.6	54
1758	0.977	3861.9	120	0	27.5	54
1764	0.979	3959.8	120	0	27.5	54
1770	0.978	4057.6	120	0	27.5	54.5
1776	0.979	4155.5	120	0	27.5	54.5
1782	0.997	4255.2	120	130	28	54.5
1788	0.996	4354.8	120	130	28	54.5
1794	0.981	4452.9	120	130	28	54.5
1800	0.98	4550.9	120	0	28	54.5
1806	0.981	4649	120	0	28.7	54.5
1812		0	120	0	29	54.5
1818		0	120	0	29	54.5
1824		0	120	0	29	54.5
1830		0	120	0	29	54.5
1836		0	120	0	29	54.5
1842		-451.8	120	0	29	54.5
1848		-451.8	120	0	29	54.5
1854		-451.8	120	0	29	54.5
1860		-451.8	120	0	29	54.5
1866		-451.8	120	0	29	54.5
1872		-451.8	120	0	29	54.5
1878		-0.9	120	0	29	54.5
1884		-0.8	120	0	29	54.5
1890		-0.8	120	0	29	54.5
1896		1.3	120	0	29	54.5
1902		68	120	0	29	54.5
1908	0.995	167.5	120	0	29	54.5
1914	1.021	269.6	120	0	29	54.5
1920	1.025	372.1	120	0	29	54.5
1926	1.037	475.8	120	0	32	54.5
1932	1.018	577.6	120	0	32	54.5
1938	1.005	678.1	120	0	32	51.4
1944	1.007	778.8	120	0	32	53

1950	1.006	879.4	120	0	32	53
1956	1.007	980.1	120	0	32	53
1962	1.007	1080.8	120	0	32	54
1968	1.025	1183.3	120	0	32	54
1974	1.009	1284.2	120	0	32	54
1980	0.992	1383.4	120	0	32.5	54
1986	1.021	1485.5	120	0	32.5	54
1992	1.002	1585.7	120	0	32.5	55
1998	1.003	1686	120	0	32.5	55
2004	1.004	1786.4	120	0	32.5	55
2010	1	1886.4	120	0	32.5	55
2016	1.02	1988.4	120	0	32.5	55
2022	0.999	2088.3	120	0	32.5	55
2028	1.001	2188.4	120	0	32.5	55
2034	1	2288.4	120	0	33.2	55
2040	1.017	2390.1	120	0	33.2	55
2046	1	2490.1	120	0	33.2	55.5
2052	0.998	2589.9	120	0	33.2	55.5
2058	1.018	2691.7	120	0	34	55.5
2064	0.999	2791.6	120	0	34	55.5
2070	0.998	2891.4	120	0	34	56
2076	0.999	2991.3	120	0	34	56
2082	0.998	3091.1	120	0	34	56
2088	0.999	3191	120	0	34	56
2094	0.998	3290.8	120	0	34	56
2100	1.016	3392.4	120	0	34	56.6
2106	1.016	3494	120	0	34.8	56.6
2112	0.998	3593.8	120	0	34.8	56.6
2118	0.998	3693.6	120	0	34.8	56.6
2124	0.998	3793.4	120	0	35	56.6
2130	0.998	3893.2	120	0	35	56.6
2136	0.999	3993.1	120	0	35	56.8
2142	0.996	4092.7	120	0	35.3	56.8
2148	1.034	4196.1	120	0	35.3	56.8
2154	0.999	4296	120	0	35.5	56.8
2160	0.997	4395.7	120	0	35.5	56.8
2166	0.997	4495.4	120	0	35.5	57
2172	0.997	4595.1	120	0	36	57
2178		0	120	0	36	57
2184		0	120	0	36	57
2190		0	120	0	36	57
2196		0	120	0	36	57
2202		0	120	0	36	57
2208		-451.4	120	0	36	57
2214		-451.9	120	0	36	57
2220		-451.9	120	0	36	57
2226		-451.9	120	0	36	57
2232		-451.9	120	0	36	57
2238		-451.9	120	0	36	57
2244		-1.4	120	0	36	57
2250		-1	120	0	36	57
2256		-1.1	120	0	36	57
2262		2.4	120	0	36	57
2268		96.7	120	0	36	57
2274	1	196.7	120	0	36	57
2280	1.026	299.3	120	0	37.7	57

2286	1.042	403.5	120	0	37.7	54
2292	1.01	504.5	120	0	37.7	54
2298	1.002	604.7	120	0	37.7	54
2304	1.028	707.5	120	0	37.7	54
2310	1.01	808.5	120	0	37.7	55.9
2316	1.008	909.3	120	0	37.7	55.9
2322	1.009	1010.2	120	0	37.7	55.9
2328	1.029	1113.1	120	0	37.7	57.2
2334	1.011	1214.2	120	0	37.7	57.2
2340	0.999	1314.1	120	0	37.7	57.2
2346	1.003	1414.4	120	0	37.7	57.2
2352	1.006	1515	120	0	37.7	57.2
2358	1.005	1615.5	120	0	38.7	57.2
2364	1.026	1718.1	120	0	38.7	57.2
2370	1.005	1818.6	120	0	38.7	57.2
2376	1.024	1921	120	0	38.7	57.2
2382	1.004	2021.4	120	0	38.7	56.8
2388	1.004	2121.8	120	0	38.7	56.8
2394	1.003	2222.1	120	0	38.7	56.8
2400	1.004	2322.5	120	0	39.4	56.8
2406	1.004	2422.9	120	0	39.4	56.8
2412	1.002	2523.1	120	0	39.6	56.8
2418	1.04	2627.1	120	0	39.6	56.8
2424	1.002	2727.3	120	0	39.8	56.8
2430	1.003	2827.6	120	0	39.8	56.8
2436	1.003	2927.9	120	0	39.8	57
2442	1.001	3028	120	0	40	57
2448	1.002	3128.2	120	0	40	57
2454	1.003	3228.5	120	0	40	57
2460	1.001	3328.6	120	0	40	57
2466	1.037	3432.3	120	0	40.3	57
2472	1.002	3532.5	120	0	40.3	57
2478	1.001	3632.6	120	0	40.3	57
2484	1.001	3732.7	120	0	40.3	57
2490	1.001	3832.8	120	0	40.3	57
2496	1.001	3932.9	120	0	40.3	57
2502	1.001	4033	120	0	40.3	57
2508	1.019	4134.9	120	0	40.3	57
2514	1.02	4236.9	120	0	40.3	57
2520	1	4336.9	120	0	40.9	57
2526	0.999	4436.8	120	0	41	57
2532	1.001	4536.9	120	0	41	57
2538	1.001	4637	120	0	41	57.3
2544		0	120	0	41	57.3
2550		0	120	0	41	57.3
2556		0	120	0	41	57.3
2562		0	120	0	41	57.3
2568		-452.1	120	0	41	57.3
2574		-452.1	120	0	41	57.3
2580		-452.1	120	0	41	57.3
2586		-452.1	120	0	41	57.3
2592		-452.1	120	0	41	57.3
2598		1.6	120	0	41	57.3
2604		-1.1	120	0	41	57.3
2610		-1.2	120	0	41	57.3
2616		2.2	120	0	41	57.3

2622		99.8	120	0	41	57.3
2628	1.017	201.5	120	0	41	57.3
2634	1.024	303.9	120	0	41	54
2640	1.022	406.1	120	0	41	54
2646	1.024	508.5	120	0	41.8	54
2652	1.005	609	120	0	41.8	54
2658	1.009	709.9	120	0	41.8	56
2664	1.008	810.7	120	0	42.1	56
2670	1.009	911.6	120	0	42.1	56
2676	1.011	1012.7	120	0	42.1	56
2682	1.031	1115.8	120	0	42.1	56
2688	1.038	1219.6	120	0	42.1	56
2694	1.001	1319.7	120	0	42.1	56
2700	1.002	1419.9	120	0	42.1	56
2706	1.005	1520.4	120	0	42.1	56
2712	1.004	1620.8	120	0	42.1	56
2718	1.005	1721.3	120	0	42.1	56
2724	1.003	1821.6	120	0	42.1	57.2
2730	1.003	1921.9	120	0	42.1	57.2
2736	1.039	2025.8	120	0	42.7	57.2
2742	1.003	2126.1	120	0	43	57.2
2748	1.002	2226.3	120	0	43	57.2
2754	1.003	2326.6	120	0	43	57.2
2760	1.001	2426.7	120	0	43	57.2
2766	1.002	2526.9	120	0	43	57.2
2772	1.003	2627.2	120	0	43	57.2
2778	1.038	2731	120	0	43	57.2
2784	1.002	2831.2	120	0	43	57.2
2790	1.001	2931.3	120	0	43	57.2
2796	1.001	3031.4	120	0	43	57.2
2802	1.002	3131.6	120	0	43	57.2
2808	1	3231.6	120	0	43	57.2
2814	1.001	3331.7	120	0	43	57.2
2820	1.019	3433.6	120	0	43	57.5
2826	1.001	3533.7	120	0	43	57.5
2832	1.018	3635.5	120	0	43.6	57.5
2838	1.001	3735.6	120	0	43.6	57.5
2844	1	3835.6	120	0	43.6	57.5
2850	1	3935.6	120	0	43.8	57.5
2856	0.999	4035.5	120	0	43.8	57.5
2862	1	4135.5	120	0	43.8	57.7
2868	1.019	4237.4	120	0	44	57.7
2874	1	4337.4	120	0	44	57.7
2880	0.999	4437.3	120	0	44	57.7
2886	1.017	4539	120	0	44	57.7
2892	1	4639	120	0	44.2	57.7
2898		0	120	0	44.2	57.7
2904		0	120	0	44.2	57.7
2910		0	120	0	44.2	57.7
2916		0	120	0	44.2	57.7
2922		-451	120	0	44.2	57.7
2928		-452.2	120	0	44.2	57.7
2934		-452.2	120	0	44.2	57.7
2940		-452.2	120	0	44.2	57.7
2946		-452.2	120	0	44.2	57.7
2952		-1.4	120	0	44.2	57.7

2958		0	120	0	44.2	57.7
2964		0.1	120	0	44.2	57.7
2970		0.1	120	0	44.2	57.7
2976		1.6	120	0	44.2	57.7
2982		88.2	120	0	44.2	57.7
2988	1.001	188.3	120	0	44.2	57.7
2994	1.02	290.3	120	0	44.2	57.7
3000	1.041	394.4	120	0	44.2	57.7
3006	1.026	497	120	0	44.2	57.7
3012	1.001	597.1	120	0	44.6	57.7
3018	1.01	698.1	120	0	44.6	57.7
3024	1.008	798.9	120	0	44.9	57.7
3030	1.008	899.7	120	0	44.9	57.7
3036	1.008	1000.5	120	0	44.9	57.7
3042	1.01	1101.5	120	0	44.9	57.5
3048	1.047	1206.2	120	0	44.9	57.5
3054	1	1306.2	120	0	45	57.5
3060	1.001	1406.3	120	0	45	57.5
3066	1.006	1506.9	120	0	45.1	57.5
3072	1.004	1607.3	120	0	45.1	57.5
3078	1.006	1707.9	120	0	45.1	57.5
3084	1.003	1808.2	120	0	45.1	57.5
3090	1.003	1908.5	120	0	45.1	57.5
3096	1.039	2012.4	120	0	45.1	57.5
3102	1.003	2112.7	120	0	45.1	57.5
3108	1.002	2212.9	120	0	45.1	57.5
3114	1.002	2313.1	120	0	45.3	57.5
3120	1.002	2413.3	120	0	45.3	57.5
3126	1.002	2513.5	120	0	45.3	57.3
3132	1.002	2613.7	120	0	45.3	57.3
3138	1.02	2715.7	120	0	45.3	57.3
3144	1.001	2815.8	120	0	45.3	57.3
3150	1.02	2917.8	120	0	45.3	57.3
3156	1.001	3017.9	120	0	45.3	57.3
3162	1.002	3118.1	120	0	45.3	57.3
3168	1.001	3218.2	120	0	45.3	57.3
3174	1.002	3318.4	120	0	45.3	57.3
3180	1	3418.4	120	0	45.3	57.3
3186	1.018	3520.2	120	0	45.3	57.3
3192	1.002	3620.4	120	0	45.3	57.3
3198	1.001	3720.5	120	0	45.3	57.3
3204	1.019	3822.4	120	0	45.3	57.3
3210	1	3922.4	120	0	45.6	57.3
3216	1.001	4022.5	120	0	45.6	57.3
3222	1	4122.5	120	0	45.8	57.3
3228	1.02	4224.5	120	0	45.8	57.3
3234	1	4324.5	120	0	45.8	57.3
3240	1	4424.5	120	0	46.2	57.3