



University of  
Stavanger

FACULTY OF SCIENCE AND TECHNOLOGY

## MASTER'S THESIS

Study programme/specialisation:

Information Technology –  
Robotics and Signal Processing

Spring/ Autumn semester, 2020

Open / Confidential

Author: Haakon Mehus

Programme coordinator: John Håkon Husøy

Supervisor(s): Arthur Flesjø

Title of master's thesis:

Active Noise Control in the Offshore Industry

Credits: 30

Keywords:

Active Noise Control, Digital Signal Processing,  
Adaptive Filtering, Subband Adaptive Filtering,  
Acoustical Engineering

Number of pages: 60

+ supplemental material/other: 10

Stavanger, June 29, 2020

Title page for master's thesis  
Faculty of Science and Technology



Faculty of Science and Technology  
Department of Electrical Engineering and Computer Science

# Active Noise Control in the Offshore Industry

Master's Thesis in Robotics and  
Signal Processing by  
Haakon Mehus

Programme Coordinator  
John Håkon Husøy

External Supervisor  
Arthur Flesjø

June 29, 2020





## *Abstract*

Hearing damage among offshore workers has been a problem for many years, and it remains one of the most common disorders in this group. A proposal to use active noise control to improve the noise conditions has thus been made. This thesis discusses whether using ANC to reduce noise in an offshore industrial environment is a reasonable measure. At the same time, it explains how it can be used in different situations and what requirements are set for achieving a functional setup; these claims are based on available literature. In addition, normalised subband adaptive filtering has proven to enhance the convergence behaviour of the LMS algorithm for highly correlated input signals. An experimental method has been used to test whether these findings can be passed on to the FxLMS algorithm, which is a further developed LMS algorithm adapted to active noise control. Simulations in MATLAB, based on a single-input single-output composition and autoregressive input signals were used to test the hypothesis.



## *Acknowledgements*

A special thank you to Professor and Programme coordinator, John Håkon Husøy, who has continuously provided expert assistance and good talks throughout the semester.

At the same time, I would also like to thank the people of Equinor, especially Arthur Flesjå and Elin Marie Halvorsen, who have kept me on my toes and also let me visit the majestic Johan Sverdrup platform.



# Contents

<b>Abstract</b>	<b>iv</b>
<b>Acknowledgements</b>	<b>vi</b>
<b>Abbreviations</b>	<b>ix</b>
<b>1 Introduction</b>	<b>1</b>
1.1 Motivation . . . . .	2
1.2 Problem Definition . . . . .	5
1.3 Use Cases . . . . .	7
1.4 Contributions . . . . .	8
1.5 Outline . . . . .	8
<b>2 Background</b>	<b>11</b>
2.1 Active Noise Control . . . . .	11
2.1.1 Challenges . . . . .	14
2.2 Adaptive Filtering for Active Noise Control . . . . .	17
<b>3 Related Work</b>	<b>27</b>
3.1 Practical Implementations of Active Noise Control . . . . .	27
3.1.1 Simple Systems . . . . .	27
3.1.2 Global Active Noise Control . . . . .	30
3.2 Previous Work on Improving Convergence Speed of LMS Algorithms . . . . .	32
<b>4 Solution Approach</b>	<b>33</b>
4.1 Introduction . . . . .	33
4.2 Analysis . . . . .	33
4.3 Proposed Solution . . . . .	36
<b>5 Experimental Evaluation</b>	<b>37</b>
5.1 Experimental Setup and Data Set . . . . .	37
5.1.1 Construction of Data . . . . .	37
5.1.2 Algorithm . . . . .	41
5.2 Experimental Results . . . . .	42
<b>6 Discussion</b>	<b>47</b>

---

6.1	Implementation of Active Noise Control in Offshore Environments . . . .	47
<b>7</b>	<b>Conclusion and Future Directions</b>	<b>51</b>
7.1	Conclusion . . . . .	51
7.2	Future Work . . . . .	52
	<b>List of Figures</b>	<b>53</b>
	<b>Bibliography</b>	<b>57</b>

# Abbreviations

<b>ANC</b>	<b>A</b> ctive <b>N</b> oise <b>C</b> ontrol
<b>LMS</b>	<b>L</b> east <b>M</b> ean <b>S</b> quare
<b>NLMS</b>	<b>N</b> ormalised <b>L</b> east <b>M</b> ean <b>S</b> quare
<b>FxLMS</b>	<b>F</b> iltered- <b>x</b> <b>L</b> east <b>M</b> ean <b>S</b> quare
<b>NSAF</b>	<b>N</b> ormalised <b>S</b> ubband <b>A</b> daptive <b>F</b> ilters
<b>HSE</b>	<b>H</b> ealth <b>S</b> afety and <b>E</b> nvironment



# Chapter 1

## Introduction

Active Noise Control (ANC) is the principle of controlling noise using a secondary sound source. The idea is that you can cancel unwanted noise by sending a noise signal of opposite phase from the speaker. As the use of active noise control has become more and more commercialised, more companies want to explore the possibilities of active noise control. The same goes for Equinor. Because there are a lot of noisy environments on an oil rig, they wanted to account for how, or if, active noise control could help reduce noise offshore.

So this thesis is the result of a request made by Equinor, towards the Faculty of Science and Technology - Department of Electrical Engineering and Computer Science at the University of Stavanger. Equinor is a Norwegian energy company, formerly known as Statoil (the Norwegian State Oil company), the name change can be viewed from the public as a company that's expanding its horizon as an energy provider and no longer focuses solely on oil and gas. That being said, they are still the largest operator in Norway and one of the largest offshore operators in the world [1].

There is also a part which focuses on the digital signal processing section of active noise control. The primary foundation of most ANC algorithms is the *Filtered-X Least Mean Square* algorithm. FxLMS is a robust algorithm that works well in most circumstances, but one issue is that the FxLMS exhibit poor convergence behaviour under certain conditions[2]. The hypothesis has been that this could be improved using *Normalised Subband Adaptive Filters*. NSAF has already proven to work with the *Normalised Least Mean Square* algorithm[3], and there is, therefore, a reason to believe that it will also work with the FxLMS algorithm.

## 1.1 Motivation

While working offshore might sound glamorous to some groups of people, there have always been risks associated with it. People might have heard about big disasters such as the *Deepwater Horizon* accident which led to the cinematic adaptation, a Hollywood blockbuster with the same name as the platform. There have also been extensive accidents on the Norwegian continental shelf. In 1980, the accommodation platform on the Norwegian oil rig *Aleksander Kielland* capsized due to bad weather and 123 of the 212 people on board lost their lives[4]. Another serious accident occurred in 2016, the *Turøy* accident, where a helicopter crashed on its way to the *Gullfaks B* platform. Sadly, all passengers lost their lives. This accident led to the use of *Airbus Helicopters H225 Super Puma* no longer being allowed in passenger transport or search and rescue missions, both in Norway and in Great Britain[5].

Although accidents like this can happen on the Norwegian continental shelf, Norway has always been a pioneer when it comes to safety in the petroleum sector. *"In its political platform 2013, the Solberg government pointed out that it will work to reduce the cost level on the Norwegian continental shelf. However, the government is aware that no cost-cutting measures will be implemented which can reduce the level of security in the industry. The Petroleum Regulations require continuous improvement, and the government's ambition for the Norwegian petroleum sector to be world-leading in terms of HSE stands - even in times of recession."*[6]. An expert group from the Norwegian Research Council consisting of people from worker and employer organisations, the Petroleum Safety Authority together with people from some of the leading supply and operator companies (including Equinor) is cooperating on how to prevent such accidents[7].

But big accidents are not the only focus area of the research council. Some offshore workers are also exposed to less severe injuries, illnesses and stresses; this affects a much higher proportion of people and often lead to late injuries after frequent exposure over extended periods. According to the Norwegian Research Council, the risk of some of these injuries and illnesses rises due to exposure to chemicals, psychological stresses, vibration, heavy physical work and noise[7]. One of the biggest problems in the offshore industry is that so many people suffer from permanent hearing injuries after frequent exposure to high volume noise during their time as an offshore worker[8]. Together with people diagnosed with musculoskeletal disorders, the hearing damaged is the largest diagnostic group of those suffering from work-related injuries or illnesses in the offshore industry.

## Noise Exposure

In a study about reporting of hearing damage in the Norwegian offshore industry that span from 1992 to 2003, the hearing loss accounted for 25% of all reported cases of work-related illness during the entire 12-year period. The number of hearing injuries varied from year to year, with an increase from 27 in 1992 to 242 in 2003[8]; this may indicate large unrecorded numbers, especially in the earlier years as it is not likely that hearing damages have increased that much when the HSE regulations have become so much stricter over the years. Newer reports have shown that cases of hearing loss in the Norwegian offshore industry were 600 annually in 2016[9], in other words, this is still an important issue.

Luckily, reducing cases of hearing damage still has a very high priority among the operators on the Norwegian continental shelf. Equinor has already put in a lot of resources to reduce noise at their new platform Johan Sverdrup, located in the North Sea. An acoustic company called Wakefield Acoustics secured a multi-million-pound contract for a project where they would go on to design and install *"17 high specification acoustic enclosures, intended to significantly reduce noise levels on the offshore platform"*[9]. From first-hand experience, people working at Johan Sverdrup say that this is by far the most silent platform they have ever visited.

Even if new platforms do not produce as much noise as the older ones, there is still a lot of areas where the noise levels are too high for it to be safe to stay for longer periods. According to the Centers for Disease Control and Prevention, exposure to noise above 70 dB over a prolonged period of time may start to damage your hearing[10]. While visiting Johan Sverdrup, measurements showed that noise levels in the range 80-90 dB were quite common and the noisiest areas went above 100 dB.

## Other Effects of Noise

Measures are already taken to prevent hearing injuries in these areas; there are strict guidelines that require everyone to use hearing protection at all times when staying in noisy areas. Along with the noise, wearing hearing protections makes it cumbersome to communicate with each other, even if they are connected to a walkie-talkie. Difficulty in communication can at worst lead to different types of accidents. High noise can have several other health effects in addition to damaged hearing, here is a list of other health effects made by the Norwegian employer organisation *Norwegian Oil and Gas*[11]:

Other health effects of high noise:

- Noise can affect the cardiovascular system.
- Noise can contribute to stress and muscle tension, even when the sound level is relatively low.
- Noise can be annoying and tiring, as well as reducing concentration and care.
- Noise can reduce restitution time and quality of sleep.
- Noise can affect pregnant women and fetuses.

Noise can also increase the risk of accidents:

- Communication becomes more difficult.
- Perception of messages and alarms given over loudspeakers is reduced.
- Noise contributes to stress.
- Noise can increase the risk of misbehaviour.
- Reduced sleep quality gives reduced concentration and attention.

Since high noise levels can have serious health consequences for offshore workers, which in itself is reason enough to invest, there will also be significant costs for both the state and employers associated with poorer employee health. No account has been taken off the price of active noise control measured against the long-term costs of sick-listed or employee's on disability benefits, but one can speculate that they would even out over time if good results are made, and more people start investing in the technology.

### **Improving Convergence Behaviour**

In addition to reducing the risk of hearing loss among workers in the offshore industry, it is a great motivation to try to influence the development of active noise control technology and adaptive filtering in general.

It is common knowledge in the field of adaptive filtering that both LMS and FxLMS algorithms suffer from poor convergence properties, especially for a highly correlated input signal[12]. Highly correlated input signals frequently occur in the offshore industry,



since the noise often originates from rotary motors operating at the same frequency over extended periods. Improving the convergence speed of these algorithms have already been done in numerous ways; using a variable step size is one example[13].

Seeing how the use of constrained subband updates has proven to work in terms of reducing the convergence time of the standard NLMS algorithm[12], it was reasonable to believe that the convergence of the FxLMS algorithm would also improve using a similar method.

## 1.2 Problem Definition

As mentioned, there are two issues in this thesis. One part is to explore the possibilities of using active noise control to reduce noise in industrial environments offshore. A thorough investigation will be done, where the goal is to find out in what ways active noise control can be used, how it can be implemented and which results can be expected from the various attack angles. From meetings with Equinor, it has become clear that their ultimate goal is to cancel the noise from the source by creating a sound barrier where noise won't get through. Hypothetically, if this could work in a way where all noise sources were sufficiently damped, then people could move around in usually noisy engine rooms or the like without hearing protection and communicate efficiently. There also exist attempts to cancel noise in a whole room or other closed cavities by strategically placing loudspeakers and error microphones throughout the room; this is more feasible if the sound comes from a particular direction, thereby making the acoustic modelling easier. Active noise cancelling in this manner, where noise is attenuated in a large three-dimensional space is called global ANC.

Another idea was to explore the possibilities of silencing a small area of a room, maybe the spaces in a room where workers would usually be located. The idea was to do this using directional sound, similar to the sound showers located around Oslo Airport, Gardermoen[14]. Many believe that these sound showers use active noise cancelling to create a comfortable mood under the speaker, in reality, there are only pleasant sounds directed like a beam at the person below in a way that makes the people around hear nothing. Specialised headsets or hearing protections aimed at the offshore industry could also be an alternative. In general, it will be studied how active noise control is used in other sectors and what has been done in previous research that is possible to obtain. The hope is that there will be found something as described that can be implemented directly or with small adjustments.



**Figure 1.1:** A sound shower, viewed at the Oslo Airport, Gardermoen[14]

No practical experimentation will be done as to whether it is possible to make such a setup as described above. Recommendations on further work will only emphasise research articles and practical implementation from the industry and business world.

### **On Convergence of FxLMS**

The initial problem definition regarding the other part of the thesis was to gather knowledge about the signal processing part of active noise control and then compare classical algorithms with newer ones. The FxLMS algorithm quickly proved to be the foundation of most applications of ANC. There are also cases where noise-cancelling using the Kalman-filter and the ADALINE neural network proved to be successful[15]. However, among the research available, it seems like different versions of the FxLMS filter is a more popular choice.

Because the FxLMS algorithm laid the foundation for most of the approaches to active noise control in the available research, exploring its potential for improvement and looking into the possibilities of realising those improvements eventually became a new goal. Given that the FxLMS algorithm is built upon the LMS algorithm, they share many of the same pros and cons. It is reasonable to believe that something that improves the LMS algorithm will also improve the FxLMS algorithm. As mentioned, both algorithms suffer from poor convergence abilities when exposed to a highly correlated input signal. So the main focus of the signal processing part of this thesis ended up being to improve the convergence behaviour of the FxLMS algorithm. An article called *Improving Convergence*

of the NLMS Algorithm Using Constrained Subband Updates showed how the subband adaptive filter algorithm "exhibited faster convergence under coloured excitation"[12]. In other words, faster convergence when certain frequency areas dominate the input signal.

Since periodic noise from rotary engines occurs regularly in the offshore industry, this seemed like a relevant approach for reducing convergence time of the FxLMS algorithm. The problem definition of this part of the thesis was, therefore, to adapt subband adaptive filtering to the FxLMS algorithm. Then measure how the different number of subbands affects the convergence speed of the algorithm, with a coloured input signal, and compare it to the standard algorithm. Keep in mind that the computational complexity will not be taken into consideration even though it will be affected when splitting the signals into multiple subbands. Note that down-sampling subband filtered signals do not cause loss of much or any information, this, in turn, will reduce the computational demand.

### 1.3 Use Cases

Active noise control can potentially be useful in many industries, and if it can be used in such a way that sound can be muted sufficiently in an open area while not taking up too much space or being too high of a cost, it will become possible in most places where noise is a problem.

There are some areas where the use of active noise control is already widespread. In headsets, it has become uncommon for the top models to come without ANC. When you read headphone reviews, the performance of the ANC is among the features that are most emphasised. One reason for it becoming so widespread in headsets is the convenience of implementing it as there are already speakers on the inside. Many also use microphones on the outside for sending speech signals while talking in the telephone or something similar. The fact that headphones are designed with small closed cavities that surround one's ear facilitates excellent ANC performance since it is precisely at the eardrum that noise cancellation is desired.

Active noise control in larger open areas is currently limited to industries that do not have significant cost constraints, such as the military and the aerospace industry. Many successful solutions for ANC have been made in these industries. Although the extension of the technology to the general sector is rarely, if ever, feasible[16], it can be noted that

the oil industry usually does not have the same cost constraints as other industries have, although costs have been largely cut in recent years due to falling oil prices.

### **A Faster Converging FxLMS**

An improved algorithm with better convergence properties on coloured noise signals than the original algorithm has multiple applications. Several areas where periodic noise occurs already uses ANC, like in the automotive industry and helicopter cabins. Periodic noise is also present in other applications like kitchen fans or general ventilation systems. These can all benefit from faster convergence. One can say the same about other noise-cancelling applications where noise sources are continually changing, as in ANC headsets. When direction and propagation of noise are changing, the algorithm frequently has to adapt to the environment, and thus a fast convergence can be appreciated. Some hearing aids also use the FxLMS algorithm to, among other things, compensate for acoustic feedback where sound leaks from the loudspeaker to the reference microphone[17].

## **1.4 Contributions**

The main objective of this thesis is to provide an overall understanding of how one can utilise active noise control in industrial environments, specifically aimed at the offshore industry. Additionally, it will explain to what extent the improvements in convergence properties of the LMS algorithm using NSAF can be passed on to the FxLMS algorithm.

There already exists research that precisely addresses the issue of implementing ANC in an industrial setting, such as these two articles, [16] and [18], by C. Hansen. However, these are getting old, and since ANC technology is continuously evolving, it is time to shed new light on this issue.

Regarding convergence behaviour of the FxLMS algorithm, there is not much available research; most articles address the convergence of the regular LMS (or NLMS) algorithm.

## **1.5 Outline**

Since one part of this thesis looks at practical implementations of ANC in the offshore industry from a broad perspective, and the other part is the more narrow digital signal processing viewpoint that might require more prior knowledge, an attempt to split them up as much as possible has been made, without making it two separate parts. The thought is that a typical department manager, without much prior knowledge when it

comes to digital signal processing, should be able to read the general part of the thesis and get a solid understanding to whether ANC is something that can be used for specific cases. The other part of the thesis will be more oriented towards researchers and students within the same field of study as my own.

Chapter 2 explains the theory and background information. First, a general but detailed description is given of how one can actively control noise and the various challenges associated with it. It then explains how the required digital signal processing algorithms work, from LMS to FxLMS and a bit about subband adaptive filtering.

Chapter 3 deals with the literature on previous research on active noise control. Here the most important articles are described concerning the relevant issues inquired.

Chapter 4 explains why normalised subband adaptive filtering was seen as a solution to improve the convergence properties of the FxLMS algorithm. At the same time, it looks at how it should be tested if the properties are improved.

Chapter 5 describes the experimental setup for testing the hypothesis and shows the results of the comparison between the convergence properties of the original FxLMS and the proposed NSAF FxLMS in terms of ANC systems with highly correlated input signals.

In Chapter 6, the results found in Chapter 5 is discussed, along with a thorough discussion of previous research regarding ANC and how the findings correspond to the industrial environments offshore.

Chapter 7 concludes based on the results, previous research and discussion and addresses the way forward.



## Chapter 2

# Background

### 2.1 Active Noise Control

Active noise control has over the recent years become a technology known well outside of the acoustic and signal processing research communities, every major headset manufacturer is now producing noise-cancelling headsets, and the popular culture is embracing it. Even if ANC has blossomed lately, it was invented a very long time ago. In 1936 Paul Lueg described in a patent how sinusoidal sound pressure waves could be cancelled by sending out identical waves of opposite phase. He did this by inverting the polarity of a loudspeaker. And in the 50s Dr Lawrence J. Fogel was granted some patents for active noise cancelling in helicopter and aircraft cabins[19].

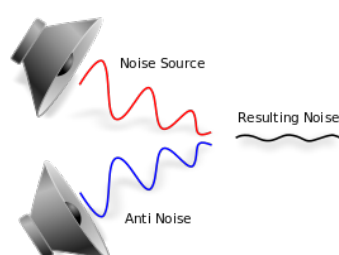
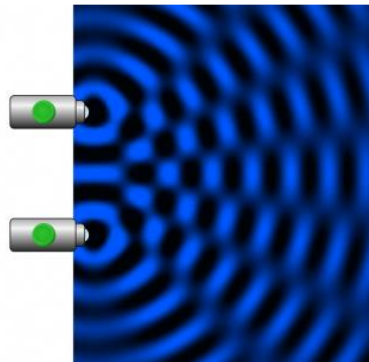

**Figure 2.1:** An illustration of the cancellation of sound pressure waves[20].

#### How It Works

The fact that ANC works are explained through the principle of superposition, where two identical sound pressure waves of opposite phase cancel each other out, is an explanation that is quite easy to understand. When an illustration like the one shown in figure 2.1 is

added to the explanation, it may sound like an easy task to implement the technology into a real-world practical situation. One would simply have to put a microphone at the noise source, connect the microphone to a loudspeaker with inverted polarity and place the speaker in the direction of the desired area of noise reduction, as long as the delays of the sound wave and the electrical signal from the microphone to the loudspeaker is aligned. Unfortunately, things are not that easy; an acoustician can tell you that sound pressure waves can not be adequately described as a one-dimensional function of time. The interference pattern should be familiar to most people who have completed a course in high school physics. The pattern is often illustrated by two sources, positioned next to each other, vibrating with the same amplitude and frequency in a pond of water. One source alone would form a circular pattern with waves moving away from the source, but as you put two sources next to each other the waves will interfere with each other, and in some straight lines the amplitude of the waves will cancel each other out; this is called destructive interference and works in the same way as when two sound waves cancel each other out. The problem is that in between each of those lines, there will also be lines where the crests meet and double in amplitude, called constructive interference and illustrated in figure 2.2.



**Figure 2.2:** Interference pattern[21]

Something similar will also happen as the sound propagates through three-dimensional space; this can be thought of as bubbles expanding out through the room, although not perfectly spherical bubbles as the shape will depend on the sound source. Reflection of sound waves from walls, ceiling, floor and other objects in a room contributes to making the situation even more complicated. A perfect model of the sound propagation in a room will, therefore, be near impossible to make. But if you had a perfect model, the acoustical pressure at one point in space would be possible to calculate with a function of three dimensions. Many loudspeakers would have to be set up in a carefully designed way to replicate sound waves in an open space situation. To engineer something like that a specific expertise within the acoustic field of study would be a requirement.



As a consequence, discussions regarding this topic will be solely based on previous research.

Even though the sound pressure waves can behave in very complex ways, there are some situations where they act in a way that is easier to predict. Headsets and closed ducts are typical applications where one can implement a well-functioning and straightforward ANC system. If one can predict the movement of the sound waves in a good way, a well-performing ANC system is still not manageable with only a microphone and a loudspeaker like mentioned before.

Take the headset example, a set up like that would be to have a microphone placed outside of the headset and use the loudspeaker inside of the headset to play anti-noise. For that to work, the noise signal hitting the eardrum would have to be an identical but delayed version of the noise signal hitting the microphone placed outside of the headset. If you have ever worn hearing protections or experienced your neighbour listening to music, you might have noticed that the low-frequency sound waves propagate easier through solid material than high-frequency sound. Both the low and the high-frequency sound waves would be attenuated but to a different degree. So sound signals coming from the loudspeaker would have to compensate for the way the noise signal changes on its way from outside the headset to the receivers eardrum. As if that wasn't enough, it would also have to compensate for the measurement error of the microphone, the analogue to digital conversion, the delay of digital signal processing, the digital to analogue conversion, the error of the loudspeaker when it converts the analogue signal to sound waves and the change of the sound signal from the loudspeaker to the eardrum. The way the sound changes on its way from the reference sensor to the area where silence is wanted is called the primary propagation path, while the way it changes going through the microphone and the loudspeaker setup to the area where silence is desired is called the secondary propagation path. In the signal processing world, these paths are modelled with transfer functions, in Section 2.2 it is thoroughly described how these propagation paths are calculated with the use of adaptive filtering. Usually, there would also be a microphone placed inside the headset, referred to as the error microphone or error sensor, as it measures the sum of the acoustic pressure from the noise and the anti-noise. This error signal, in combination with the reference signal, is used to send feedback to an adaptive filter so that it can adapt to the situation.

## Active vs. Passive Noise Control

Over the years, active noise control has proven to be better at cancelling the low-frequency noise than the more high-frequency noise, which in theory makes it perfect to combine with passive noise control. Passive noise control is usually constructed in a way where solid matter is placed in between the noise source and the area where attenuation is wanted. As explained above, low-frequency waves travel easier through solid matter than high-frequency ones as they carry less energy[22]. As active noise control is better at handling low-frequency noise, and the opposite is true for passive noise control. Since the two types are complementary towards each other, a combination would mean that you could control a wide band of frequencies.

### 2.1.1 Challenges

Implementing a well-functioning ANC set up in an open environment is a very complicated task, especially if the desired quiet zone is not already constructed in such a way that ANC is foreseen. There are many challenges one must overcome when engineering a noise-cancelling setup.

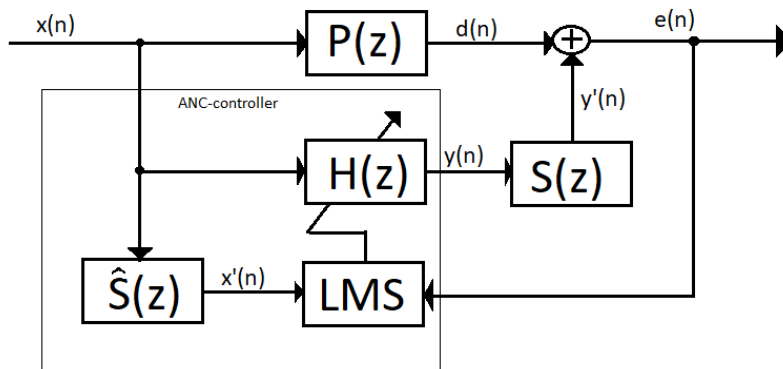

**Figure 2.3:** A block diagram of the FxLMS algorithm[23].

In Figure 2.3 a block diagram of the filtered-X LMS algorithm is shown,  $P(z)$  is the transfer function of the primary propagation path and  $S(z)$  is the transfer function of the secondary propagation path as described in 2.1. The idea is to model these with an adaptive filter so that:

$$X(z)P(z) = -X(z)H(z)S(z) \quad (2.1)$$

Which means that the adaptive filter must attempt at converging towards:

$$H(z) = -P(z)/S(z) \quad (2.2)$$

The secondary path is what separates this from a regular system identification problem where one would only apply the regular LMS algorithm. To ensure convergence of the algorithm, one must filter the input value,  $x(n)$ , with an estimate of the secondary path  $\hat{S}(z)$ , hence the filtered-x LMS. The FxLMS algorithm will be discussed in greater detail in section 2.2, but to estimate the secondary path it is necessary to remove all other sounds from the room and typically send white noise from the loudspeaker to the error sensor; this needs to be done now and again to ensure its always up to date with the current propagation path. Thus it is required that the setup is placed in an environment where it is possible to remove all other noises.

### Noise Source Characteristics

As mentioned, active noise control is best suited for low-frequency noise[24]; this places certain requirements on the equipment where the sound is to be cancelled. Fortunately, noise sources in industrial environments mostly emit noise below 1 kHz, especially if passive noise control is already implemented. The positioning of the noise source is also essential as there should be room for placing the loudspeakers in a way where the delay in secondary propagation path is lower than the delay of the primary propagation path due to the principle of causality. Causality is of great importance in a feedforward ANC system, if lacking, the ANC controller would have to estimate the noise ahead of time, and only being able to control periodic or narrow-band noise. On the other hand, if the causality condition is met, random broadband noise can also be controlled effectively[25].

### Virtual Sensing

The positioning of error sensors is just as important as the positioning of loudspeakers because feedback to the algorithm is essential for good performance. The desired place of cancellation is often around the ears of those near the noise source, and the placing of physical sensors in such positions can be too cumbersome. When a physical sensor becomes too impractical a virtual sensor is a better option.

A virtual sensor is a sensor that can measure something (for example, sound pressure) without being physically present. In the case of ANC, microphones are placed in an area near the desired quiet zone so that the sound pressure can be estimated at all positions in three-dimensional space within the quiet zone. Several algorithms can be used for virtual sensing, although some of them only seem to perform effectively on low frequencies and when the actual sensor is close to the virtual sensor[26]. The Kalman-filter has, on the other hand, proven to work over a wide variety of frequencies in real-world

experimentation[27].

Something that will significantly impact the performance of both the virtual sensor and the active noise control is whether the desired quiet zone is static or dynamic, a dynamic zone would, for example, be around the head of moving person. A moving virtual sensor is a tough task, although the Kalman-filter has shown good results in such cases[26]. Along with the ability to measure the sound anywhere in the room, it would also be necessary to know precisely where sound must be attenuated. A possibility for finding the exact position is through the use of machine vision and head tracking; this is already a built-in feature in some programming libraries, and excellent results can be expected. If the accuracy of the position of the virtual sensor needs to be high, it would probably require two cameras for head tracking to get a good measure for depth. Keep in mind that the use of video cameras and microphones in such a setting must also comply with privacy regulations.

In addition to head tracking, an arrangement with a moving quiet zone would also require control of the noise sent from the loudspeakers at all these points in three-dimensional space. A speaker array or an audio spotlight are solutions to such problems; these are ways of focusing and steering the sound field in the direction desired[16].

### **The Effect of Sound Propagation**

As mentioned, the likelihood of whether a noise cancellation setup will succeed increases significantly if the noise source and the desired quiet zone is positioned in a good way relative to each other. Both the shape and size of the area where noise-cancelling is taking place are also of great significance; this will affect both the primary and secondary propagation path. A complicated propagation path means a complicated impulse response, which will require many filter weights to model correctly. The propagation path becomes more complex as the number of acoustic modes increases, among other things. Acoustic modes are caused by sound reflecting off of various room surfaces[28], and the impulse response tells how a system would respond to an impulse in the input signal. If this impulse reflects off of various surfaces before it reaches the error sensor, the impulse response will stretch over a longer period of time before it settles down. It requires enough filter weights to model an impulse response correctly so that the adaptive filter includes all the important details of the response.

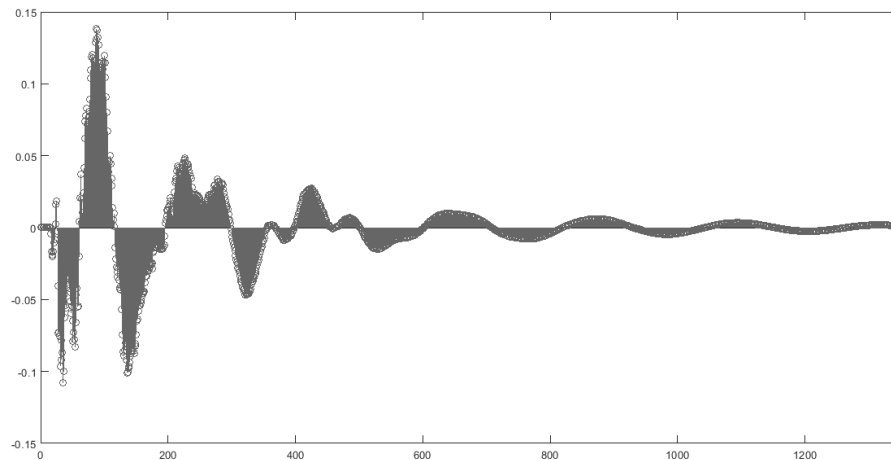

**Figure 2.4:** An impulse response

A long impulse response leads to slower convergence and higher computational demand. In Figure 2.4, an example of the first 1300 weights of an impulse response is shown. The response is gradually attenuated as time goes by, and when sufficiently damped, one can neglect the remaining filter weights as they are not necessary to obtain a good enough model of the response.

## 2.2 Adaptive Filtering for Active Noise Control

Most ANC systems use adaptive filtering to control noise, and the Filtered-X Least Mean Square algorithm is the building block of the signal processing part in most setups. The algorithm builds on the more well-known LMS algorithm that other system identification problems have benefited from for a long time. In order to understand the FxLMS algorithm, one should first understand the principles of the original LMS algorithm.

### The Least Mean Square Algorithm

The Least Mean Square algorithm is a well-known algorithm in the field of digital signal processing and system identification; it causes an adaptive filter to converge towards the Wiener-filter solution without relying on auto-correlations and cross-correlations[29].

The main application of the algorithm is to estimate the effect a system has on an input signal, and then to emulate it. In Figure 2.5, a system identification problem shows how the adaptive filter  $H(z)$  tries to mimic the system  $P(z)$  using LMS, or in this case, the

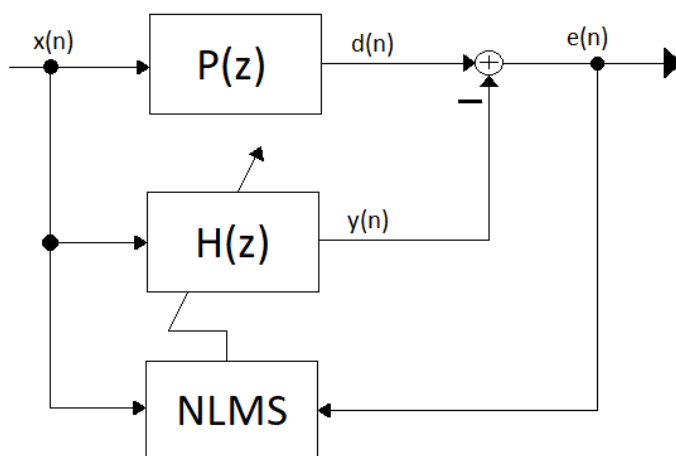

**Figure 2.5:** Block diagram of the Normalized Least Mean Square algorithm.

Normalised LMS. LMS uses a method of stochastic gradient descent; this means that the filter weights  $[h_0, h_1, \dots, h_N]$  minimises a cost function, which is the estimate of the mean square error for this particular algorithm.

$$J(h) = E\{e^2(n)\} \quad (2.3)$$

The error signal can also be written like  $e(n) = d(n) - y(n) = d(n) - h^T x(n)$  thus the expectation can be expressed as shown in Equation 2.4.

$$E\{e^T(n)e(n)\} = E\{(d(n) - \underline{h}^T \underline{x}(n))(d(n) - \underline{x}^T(n)\underline{h})\} \quad (2.4)$$

$$E\{e^2(n)\} = E\{d^T(n)d(n) - \underline{h}^T \underline{x}(n)d(n) + \underline{h}^T \underline{x}(n)\underline{x}^T(n)\underline{h}\} \quad (2.5)$$

$$E\{e^2(n)\} = E\{d^2(n)\} - 2\underline{h}^T E\{\underline{x}(n)d(n)\} + \underline{h}^T E\{\underline{x}(n)\underline{x}^T(n)\}\underline{h} \quad (2.6)$$

One can also express Equation 2.6 as Equation 2.7.

$$E\{e^2(n)\} = \sigma_d^2 - 2\underline{h}^T \underline{\Delta}_{xd} + \underline{h}^T \mathbf{R} \underline{h} \quad (2.7)$$

Since this cost function is convex, its minima can be found where the gradient, or the partial derivative with respect to the filter weights of the impulse response, is equal to zero. So by setting the gradient of Equation 2.7 with respect to  $\underline{h}$ , equal to zero, you get;

$$\nabla_{\underline{h}} E\{e^2(n)\} = -2\underline{\Lambda}_{xd} + 2\mathbf{R}\underline{h} = 0 \quad (2.8)$$

Rearranging Equation 2.8, we get the Wiener solution;

$$\mathbf{R}\underline{h} = \underline{\Lambda}_{xd} \quad (2.9)$$

Note that the LMS algorithm does not depend on stochastic variables, but these can be estimated in the following way.

$$\begin{aligned} \underline{\Lambda}_{xd} &\rightarrow \hat{\underline{\Lambda}}_{xd} = \underline{x}(n)d(n) \\ \mathbf{R} &\rightarrow \hat{\mathbf{R}} = \underline{x}(n)\underline{x}^\top(n) \end{aligned} \quad (2.10)$$

Therefore, one can find the gradient of the cost function using deterministic estimators, as shown in Equation 2.11, 2.12 and 2.13.

$$\nabla_{\underline{h}} E\{e^2(n)\} = -2\underline{x}(n)d(n) + 2\underline{x}(n)\underline{x}^\top(n)\underline{h} \quad (2.11)$$

$$\nabla_{\underline{h}} E\{e^2(n)\} = -2\underline{x}(n)(d(n) - \underline{x}^\top(n)\underline{h}) = -2\underline{x}(n)e(n) \quad (2.12)$$

$$\nabla_{\underline{h}} E\{e^2(n)\} = -2\underline{x}(n)e(n) \quad (2.13)$$

Since the optimal solution is when the gradient is zero, updating the filter weights in the opposite direction of the gradient will lead closer to the minima of the cost function, given that the step size  $\frac{\mu}{2}$  is not too large. The step size is chosen in advance, but using too large steps will result in an unstable system. Equation 2.14 and 2.15 show how the filter weights  $\underline{h}$  is updated with the LMS algorithm.

$$\underline{h}(n+1) = \underline{h}(n) - \frac{\mu}{2} \nabla_{\underline{h}} E\{e^2(n)\} \quad (2.14)$$

$$\underline{h}(n+1) = \underline{h}(n) + \mu \underline{x}(n)e(n) \quad (2.15)$$

In Figure. 2.5 the Normalised Least Mean Square algorithm is used. The standard LMS algorithm lacks robustness towards variations in the power of the input signal

as significant increases in power will cause instability and decreases will cause slow convergence rates. To compensate for a varying input signal, the normalised LMS algorithm makes the learning rate adapt according to the instantaneous power of  $\underline{x}(n)$ , which is the  $[M \times 1]$  vector  $[x(n), x(n-1), \dots, x(n-M+1)]^T$ .

$$\mu(n) = \frac{\mu}{\|\underline{x}(n)\|^2} = \frac{\mu}{\underline{x}^T(n)\underline{x}(n)} \quad (2.16)$$

The NLMS weight update iteration can then be written like Equation 2.17.

$$\underline{h}(n+1) = \underline{h}(n) + \mu \frac{\underline{x}(n)e(n)}{\underline{x}^T(n)\underline{x}(n)} \quad (2.17)$$

### The Filtered-X Least Mean Square Algorithm

The FxLMS or FxNLMS, normalised for input signal power, is a version of the LMS algorithm that is heavily used in the field of Active Noise Control. Since the secondary propagation path  $S(z)$  also will affect the response of the system that needs to be identified, see Figure 2.6, the regular NLMS algorithm will generally cause instability.

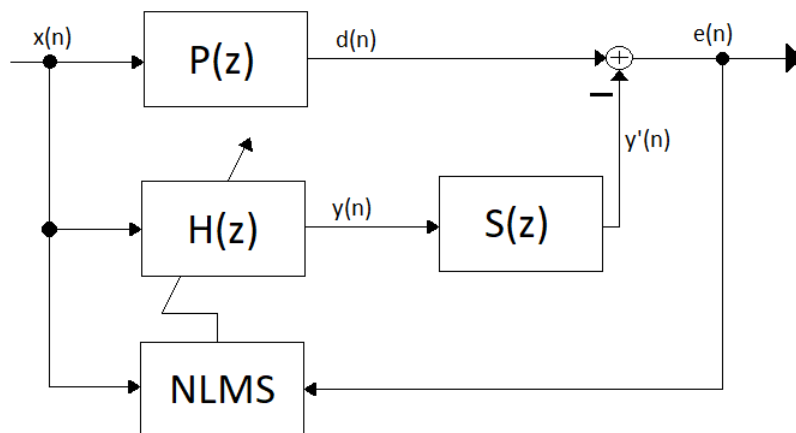
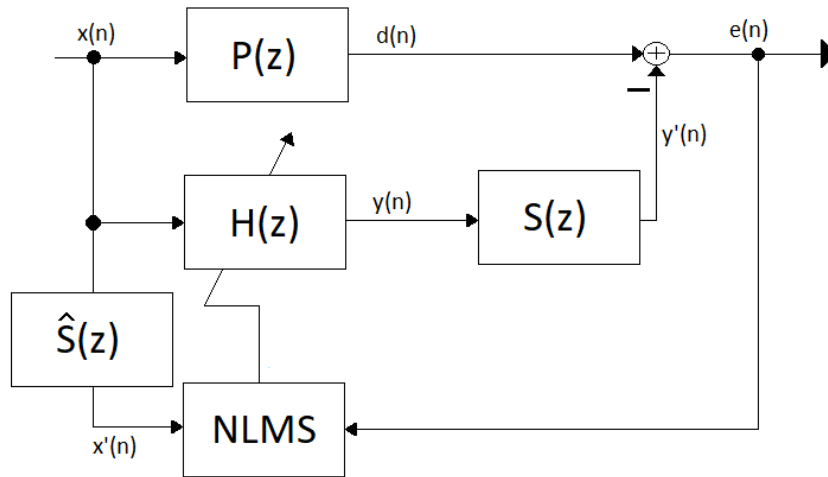

**Figure 2.6:** The NLMS algorithm where the secondary path,  $S(z)$ , is included

The error signal will no longer be correctly aligned in time with the reference signal due to the influence of the secondary path. These effects can be compensated for in many different ways; one possibility is to place  $\frac{1}{S(z)}$  in series with the secondary path. Unfortunately, this is an option which is not always realisable as the inverse of the secondary path doesn't exist under all circumstances[25].

Another alternative is the Filtered-X Least Mean Square algorithm, first proposed by Morgan in 1980 for feedback systems before it was independently introduced by Widrow





**Figure 2.7:** The FxNLMS filters the input signal with an estimate of the secondary path.

and Burgess in 1981 for feedforward systems[30]. This solution filters the input signal,  $x(n)$ , with an estimate of the secondary propagation path before the NLMS algorithm is applied (Figure 2.7), thereby the Filtered-X Least Mean Square.

As mentioned in Section 2.1, the optimal solution that the adaptive filter should converge towards is:

$$H^o(z) = \frac{P(z)}{S(z)} \quad (2.18)$$

### Modelling of ANC Systems

ANC systems can be modelled in many ways, a system like the one in Figure 2.7 is a SISO (single-input, single-output) system, where you have one reference sensor and one error sensor. A SISO system is the most straightforward kind of active noise control system. Real-world cases that can be modelled with such a system are typically headsets, ducts, or other places where the noise comes from a particular direction, and the area of desired silence is very specific. There are some cases where the secondary propagation also affects the reference sensor, giving feedback. For example, when a loudspeaker is placed in a duct, the sound coming from it would often propagate back to the reference sensor that is also positioned in the same duct.

In Figure 2.8 a block diagram of an ANC system where there is feedback from the loudspeaker to the reference sensor is shown, this will complicate the system that the

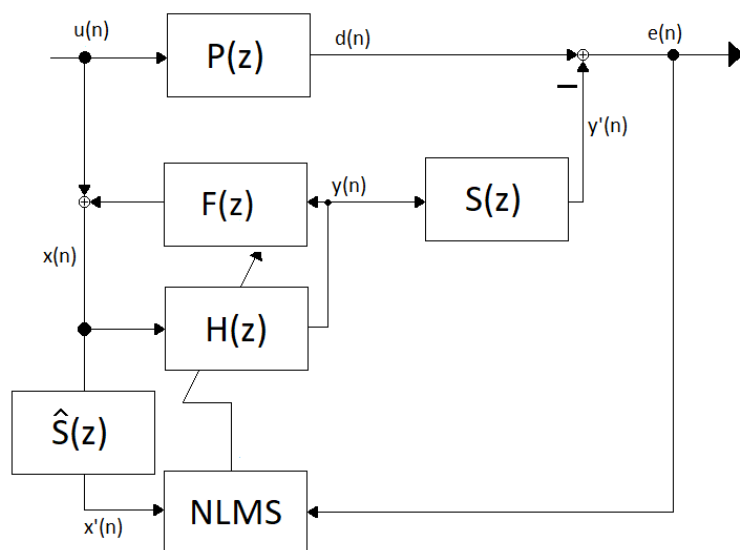

**Figure 2.8:** Block diagram of FxNLMS with feedback from loudspeaker to reference sensor[25].

adaptive filter is trying to emulate. The optimal filter will thus be:

$$H^o(z) = \frac{P(z)}{S(z) + P(z)F(z)} \quad (2.19)$$

Feedback can be compensated for by estimating the impact the speaker sound has on the reference sensor, in the same way that the secondary propagation path of the error sensor is estimated, by sending white noise through the loudspeaker and calculating its impulse response with the LMS algorithm. Since there is a requirement that all other noise sources must be dampened every time the secondary path and the feedback path is estimated, it is a good thing that it can be done at the same time for both  $\hat{S}(z)$  and  $\hat{F}(z)$ [31]. When the feedback path,  $\hat{F}(z)$ , is estimated properly, the filter can be put in parallel with the real propagation so that  $X(z) = U(z) - Y(z)\hat{F}(z)z^{-1}$  where  $U(z)$  is the sum of the acoustic pressure from the noise source and the sound from the speaker as they reach the reference sensor, see Figure 2.9.

## MIMO Systems

A SISO system is rarely sufficient for attenuating noise in open environments. Generally, muting a large enough area can only be done using multiple reference sensors, speakers, and error sensors. Such a system is called a "Multiple-Input Multiple-Output system" (MIMO). Setting up a MIMO system can be executed in several different ways, and there are many different ways to model them. Although a MIMO system probably will describe a possible system for use in the offshore industry in a better way than a SISO one, this

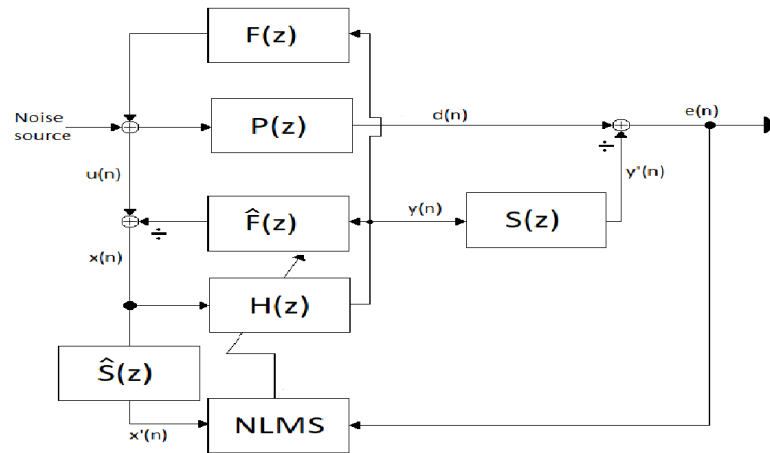

**Figure 2.9:** Estimate of feedback filter to compensate for the real feedback.

thesis will focus on trying to improve the FxLMS algorithm in a SISO system without feedback from the secondary source to the reference sensor. In terms of improving the convergence of the algorithm using NSAF's (Normalised-Subband Adaptive Filters), there is good reason to believe that improvements done on a SISO system can be transferred directly to the MIMO system. The complexity of analysing a MIMO system will be too time-consuming for it to be suitable to do in conjunction with this task. Not knowing how the end product will look like, making the most straightforward system possible, which is still relevant, is a smart choice. Neglecting the feedback from the loudspeaker to the reference sensor was done since there was no way of measuring the propagation in a room where turning off the different noise sources was not an option.

### Normalised-Subband Adaptive Filters

Where a regular adaptive filter tries to mimic the impulse response of a system by looking at both a broadband input- and error-signal, a subband adaptive filter split both the input- and error-signal into multiple subband signals, applying the adaptive algorithm on each subband. Subband adaptive filtering is one of the most common ways to reduce both computational complexity and convergence rate[32]. Few algorithms are robust towards input signals with certain characteristics. If these characteristics only appear in specific frequency bands of the signal, a subband adaptive filter would still converge in the areas where these characteristics do not occur.

Normalised-Subband adaptive filters can improve the NLMS algorithm by updating the filter weights based on subband filtered input and error signals, see Equation 2.20.

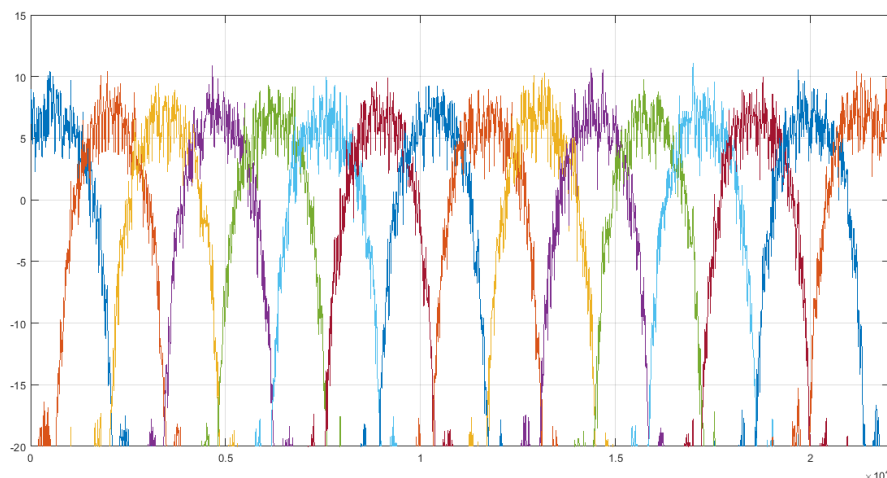

**Figure 2.10:** Power spectrum of white noise split into 16 subbands using ELT (Extended Lapped Transforms) and Welch's method for the averaged windowed periodogram.

$$\underline{h}(k+1) = \underline{h}(k) + \mu \sum_{i=0}^{N-1} \frac{\underline{x}_i(kN)e_i(kN)}{\|\underline{x}_i(kN)\|^2} \quad (2.20)$$

Where  $\underline{x}_i(kN)$  is a block of the input signal,  $\underline{\tilde{x}}(kN)$ , filtered by the  $i$ 'th subband filter,  $\underline{f}^{(i)}$ .

$$\underline{x}_i(kN) = \mathbf{F}_i^T \underline{\tilde{x}}(kN) \quad (2.21)$$

If  $M$  is the number of filter weights in the adaptive filter and  $L_f$  is the length of the subband filters, then  $\mathbf{F}_i^T$  is a  $[M \times M + L_f - 1]$  sized matrix.

$$\mathbf{F}_i^T = \begin{bmatrix} f_0^i & f_1^i & f_2^i & \dots & 0 \\ 0 & f_0^i & f_1^i & \dots & 0 \\ 0 & 0 & f_0^i & \dots & 0 \\ \vdots & \vdots & \vdots & \ddots & \vdots \\ 0 & \dots & f_{L_f-1}^i & f_{L_f}^i & 0 \\ 0 & \dots & f_{L_f-2}^i & f_{L_f-1}^i & f_{L_f}^i \end{bmatrix} \quad (2.22)$$

And the scalar  $e_i(kN)$  is the full band error vector,  $\underline{e}(kN)$ , filtered with subband number  $i$ .

$$e_i(kN) = \underline{f}^{(i)\top} \underline{e}(kN) \quad (2.23)$$

$$\underline{e}(kN) = \underline{d}(kN) - \mathbf{X}^\top(kN)\underline{h}(k) \quad (2.24)$$

$\underline{d}(kN)$  is of size  $[L_f \times 1]$ ,  $\mathbf{X}(kN)$  has size  $[M \times L_f]$  and  $\underline{h}(k)$  is the adaptive filter weights of length  $M$ .

This article, [12], showed how convergence behaviour of the NLMS algorithm was improved using this technique. This will be further addressed in the next chapter, along with related literature on implementations of ANC for industrial use.



## Chapter 3

# Related Work

Active noise control has been a broadly studied subject for many years; as mentioned in Chapter 1. It is a vast field where one can look at ANC from a high number of angles, and the signal processing part doesn't show the full picture. Analysis of how sound propagates through space and reflects from various surfaces in a room is a field of study where an acoustic background is required. People have long believed that ANC would get its breakthrough within a couple of years[16]. Except for in industries where active noise control is particularly suitable or where they do not have the same cost constraints, there have not been any universal breakthrough for commercial use. A reason for this may be that making individual adaptations for each approach usually is a necessity. Regardless, there is a lot of research available, and one can get inspired by other industries where successful implementations have taken place.

### 3.1 Practical Implementations of Active Noise Control

There is a vast amount of research on practical examples of active noise control. Many provide similar insights while some stands out to a greater extent. This chapter presents what has been found most relevant to the current issue.

#### 3.1.1 Simple Systems

One can model a simple ANC system with a block diagram like the one shown in Figure 2.3, and typically only needs one reference sensor, one loudspeaker and one error sensor. As mentioned, such systems generally are ANC headphones or ventilation ducts. It is not easy to find any data that shows how much of the attenuation in modern ANC headphones is due to the active noise control, and how much is because of passive sound

isolation. Commercial ANC headphones (like the ones produced by Sony, Bose etc.), which one could assume to use state of the art in terms of active noise control technology, have mostly been tested for consumer reviews. But there are a few research articles that address this issue.

In an experiment, [33], performed at the intensive care unit, scientist measured the exposure to noise over 24 hours using three polystyrene model heads where one was equipped with a regular headset without ANC, another with an ANC headset and the third was a control head for measuring the real noise exposure without protection. The general noise level was measured using a frequency scale that represents how the human ear perceives the amplitude of the different frequencies. Noise levels were sampled every second during the 24-hour interval. The measurements showed that the average noise level at night was about 53 dB and closer to 60 dB during the day. Results revealed that the noise levels dropped 5.12-8.47 dB, relative to the control source, using a 95 % confidence interval. Relative to the headset without ANC, the noise levels dropped 2.45-5.80 dB using a 95 % confidence interval. Note that the passive noise reduction achieved by such headsets is not as good as in proper hearing protection, but the experiment shows the effect of ANC in a real-world setting.

The article, "*Headset Prototype Design for Industrial Noise Reduction Using DSP*" [34], describes the design and performance of a headset prototype aimed explicitly for use in industrial environments. The prototype consists of a standard headset with one microphone outside (reference sensor) and another one inside (error sensor) of the ear cup. It uses 128 filter taps to represent the estimated secondary path and the adaptive filter, and a standard version of the FxLMS algorithm for producing the anti-noise. A basic setup like this was able to achieve a maximal power reduction of 23-30 dB in the frequency range from 0 to 500 Hz, making it complementary to passive noise reduction systems that perform better for higher frequencies.

The spectral properties of the input signal are not clarified in, [34], even though it will affect the results. Another thing that will affect the performance of an ANC headset is the shape of the head and ear of the person using it. This article, [35], discusses how the secondary path is affected by how well the headset is attached. Lack of proper sealing around the headset can cause significant variation in the performance of the active noise control. An experiment was carried out in which several different headsets were tested on many different simulation manikins, with microphones placed inside human-like ears. Tests showed that the attenuation levels varied as much as 15 dB for the same headset



on different ear simulators.

There are already earplugs explicitly made for offshore installations with active noise-cancelling capabilities. The QuietPro earplugs was initially created for military use by the scientist from the acoustical community at SINTEF. Later a separate version was created with offshore noise exposure in mind. In the frequency area 0-8000 Hz these have shown to have a total attenuation of about 30-40 dB when considering the sum of active and passive noise-cancelling. At the lowest frequencies, 0-500 Hz, the active noise control accounts for up to 15 dB of the total attenuation. These earplugs are also designed in such a way that they monitor the overall noise exposure and alert you if dangerous levels are approaching. At the same time, they have a feature that makes them robust to leaks, which can corrupt the attenuation, by playing a sound and then measuring how much is perceived by the reference sensor. An attenuation level of 20 dB is required for usage. Additionally, they let sounds that are below dangerous levels through, in order not to reduce alertness[36].

As described in Chapter 2, active noise control in ducts can also be achieved using only one reference sensor, one loudspeaker and one error sensor. There are several examples of successful implementations of such systems. For example, there is an Israeli company called Silentium that helped the Italian company Faber make "the world's quietest Range Hood"[37]. This article describes "The Simulation and Implementation of an Active Noise Control System in a Laboratory Duct"[38]. They first achieved an attenuation of 17 dB using a single channel ANC set up like the one shown in Figure 3.1. The performance of the ANC system was reduced because of acoustic feedback from the secondary source to the reference sensor. One reason for the size of the feedback was that the secondary source was perpendicular to the duct, and the primary source, by changing the angle more towards parallel the attenuation increased to 21 dB. After measuring the acoustic feedback and implementing a filter to compensate for it, the primary noise was reduced with 24 dB.

If the noise source is a rotary motor, it is possible to compensate for the acoustic feedback in another way; by replacing the reference microphone with a rotating speed sensor, one can compute the fundamental frequency. The rotating speed of the engine won't be affected by sound from the secondary source. A research experiment used this solution, [39], and an average amount of noise elimination of 20 dB was accomplished at the fundamental frequency of 215 Hz.

Active control of noise in open areas requires more sophisticated solutions, and the examples mentioned above will not apply to such systems. *"When the noise field of*

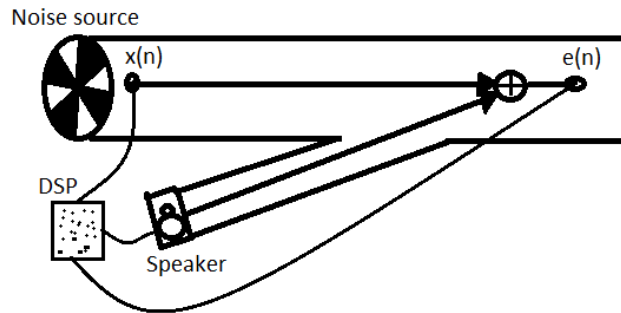

**Figure 3.1:** Illustration of a duct system

*interest increases in size and bandwidth, the number of acoustic modes increases"*[40]. Therefore, a multichannel system is needed.

### 3.1.2 Global Active Noise Control

*"It has been shown by a number of authors that it is not feasible to attain global sound reduction using active control of large enclosed sound fields"*[16]. This claim stems from an article published in 2004 on current and future applications of active noise cancelling. Since then, some progress has been made in the development of active noise control technology. To achieve global control of noise, one has to minimise the acoustic potential energy in the room. Previous work estimated the acoustical pressure using virtual sensors based on real acoustical sensors spread throughout the room. According to this article, [41], that method wouldn't give an accurate estimate unless the room has the shape of a square box.

D. Halim showed in 2011 that it was possible to estimate a broadband interior acoustic sound pressure, using structural vibration sensors in a vibro-acoustic cavity[42]. Making it feasible to determine the acoustic potential energy of more complex cavity shapes. In this article, [41], they used a combination of structural vibration sensors and microphones for virtual sensing and estimation of the acoustic potential energy. A reduction in acoustic potential energy of 1.9 dB and 9.5 dB was realised for, respectively, the modal amplitudes of 170 Hz and 250 Hz. Note that the acoustic pressure also increased in some parts of the room.

The aerospace industry was the first to introduce active noise cancelling in headsets; they also invest heavily in global ANC for reducing engine and wind noise. There does not

seem to be much evidence of achieving global noise control in a large aerospace cabin. Most of the research deals with noise cancellation in a small static area, typically around the ears of the pilots. In a mock-up of a loadmaster area in a military aircraft, researchers were able to attenuate noise at 12, 16 and 3 dB at the first three harmonics 92, 184 and 276 Hz in the first load case. The attenuation in the other load case was slightly weaker with 13, 5 and 4 dB for 97, 194 and 291 Hz. In this case, the sound attenuation occurs around the head position of a person who would be seated. These results were achieved using individual weighting parameters for each loudspeaker and microphone, making it robust in terms of misplacing the mics and speakers and therefore reducing the work needed for a perfect setup[43].

In the automotive industry, more and more manufacturers are starting to adopt active noise reduction. Cars should be well suited for ANC since it is a closed vibro-acoustic cavity with noise coming from the outside in the form of a rotary engine and wind noise. It is also mainly around the ears of the driver and passenger that attenuation is needed. In 2011, the Japanese manufacturer Honda created a system that was able to attenuate tonal noise below 100 Hz with 10 dB reduction in a commercial midsize car[40]. An experiment in this article, [40], claims to achieve a noise reduction of 15-35 dB in the frequency range 50-500 Hz around the headrest in the driver seat. The same article also states that third party audio developers such as Bose and Harman, deliver ANC solutions to car manufacturers.

This thesis also looks at the possibility of cancelling the noise at the source. Few research papers address this issue. One article, [44], describes how active noise control can be used as a supplement to a passive noise barrier for better performance. In this case, a passive noise barrier means a wall that does not let sound pass. Such a barrier without ANC supplement has to be built very tall and wide as the noise diffracts around the edges. By setting up secondary sound sources at the diffraction edge, attenuation of 30 dB for pure tones of both 250 and 500 Hz was achieved at the same height as the diffraction edge. More than 12 dB was attained at almost every point. An important note about this experiment is that it took place in an anechoic chamber, which facilitates a well-performing ANC system. Transformer noise can also be attenuated at the source, according to [25], experiments using four loudspeakers and six error microphones reduced the sound levels at the harmonics of the 60 Hz power frequency. Attenuation of 15-20 dB over 35-40 degrees of azimuth at 120 Hz, and 12-15 dB over 15-35 degrees of azimuth at 240 Hz.

## 3.2 Previous Work on Improving Convergence Speed of LMS Algorithms

As the LMS algorithms exhibit poor convergence capabilities for highly correlated input signals, different solutions already exist. Note that there are certain limitations to the Filtered-X LMS compared to the general LMS algorithm, which means that applying these solutions to the FxLMS algorithm won't always be achievable. Making individual adjustments is often a requirement for passing it on to FxLMS.

K.A. Lee and W.S. Gan showed in this article, [12], how subband adaptive filtering can improve the convergence rate of coloured input signals. As the manipulation of each subband signal is attainable with SAF, one can utilise the properties of every subband individually and make those with well-suited characteristics converge independently. Using the same step size,  $\mu = 1$ , and a Monte Carlo simulation, the NSAF NLMS algorithm performed better than the original NLMS algorithm. Performance improved even further as the signals were divided into more sub-bands.

A similar experiment has been done to see if these properties also manifest when used on the FxLMS algorithm. A description of these experiments follows in the coming chapters.

## Chapter 4

# Solution Approach

### 4.1 Introduction

After seeing how the convergence speed of the regular NLMS algorithm was improved using normalised subband adaptive filters, it became natural to try the same procedure for the FxLMS algorithm. The fact that this method is aimed mainly towards input signals where the correlation is high made the NSAF solution particularly attractive for noise control in industrial environments.

### 4.2 Analysis

Since oil rig noise sources are often rotary engines or other machines that produce correlated noise, it is reasonable to believe that an active noise control setup with the regular FxLMS algorithm will exhibit poor convergence properties. A highly correlated input signal will cause a large eigenvalue spread in the autocorrelation matrix of the input signal[45]. The condition number  $k(R)$ , where  $R$  is the autocorrelation matrix, is a measure for the eigenvalue spread — using the ratio of the highest and the lowest eigenvalue to calculate the condition number.

$$k(R) = \frac{\lambda_{max}}{\lambda_{min}} \quad (4.1)$$

The spread of the eigenvalues is directly related to the convergence behaviour of LMS algorithms[32], and a ratio close to one is desirable. When the input signal fed to the algorithm is an AR(1) signal;  $x(n) = 0.9x(n - 1) + w(n)$ ,  $w(n)$  being white Gaussian

noise, the effective eigenvalue spread has been shown to decrease by splitting the input signal into more subbands[46].

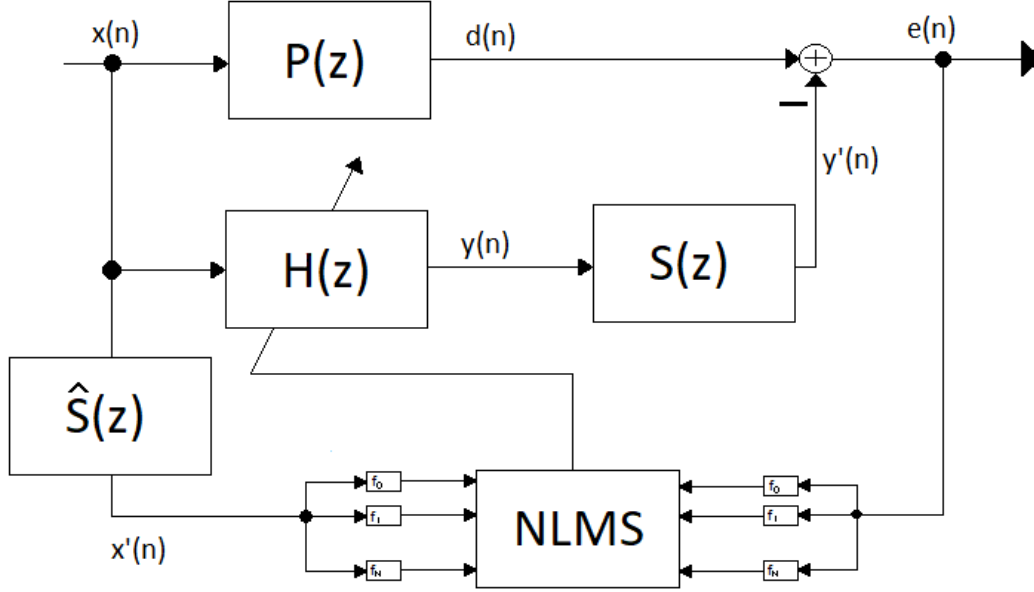

**Figure 4.1:** Illustration of the NSAF FxNLMS algorithm

Contrary to the way subband adaptive filters are implemented in [12]; there is no way of subband filtering  $d(n)$  and  $y'(n)$  in the FxLMS algorithm as it is not possible to measure them individually. While the FxLMS algorithm updates its weights in the manner shown in Equation 4.2, the NSAF FxLMS updates the weights based on the subbands of the filtered reference signal and the error signal; as shown in Equation 4.3.

$$\underline{h}(n+1) = \underline{h}(n) + \mu \frac{\underline{x}'(n)e(n)}{\|\underline{x}'(n)\|^2} \quad (4.2)$$

$$\underline{h}(n+1) = \underline{h}(n) + \mu \sum_{i=0}^{N-1} \frac{x_i(n)e_i(n)}{\|\underline{x}_i(n)\|^2} \quad (4.3)$$

Notice that  $N$  is the total number of subbands used in the algorithm, splitting the already filtered input signal into  $[\underline{x}'_0(n), \underline{x}'_1(n), \dots, \underline{x}'_N(n)]$  and the error signal into  $[e_0(n), e_1(n), \dots, e_N(n)]$ , in this way, each subband will affect the convergence of the algorithm.

Pre-made filters, based on the ELT (*Extended Lapped Transform*) method[47], were used for subband filtering the input and error signals.

## Optimal Step Size

To get a fair comparison between FxLMS and NSAF FxLMS, one should use the same step size in both cases. Also, it is desirable to use a near-optimal step size, which best represents what would be applied in real situations. In the NLMS algorithm, the optimal step size is 1; unfortunately, this cannot be passed on to the FxLMS algorithm. In stochastic approaches, the step size has to be between zero and two divided by the highest eigenvalue of the autocorrelation matrix of the input signal; see Equation 4.4[48].

$$0 < \mu < \frac{2}{\lambda_{max}} \quad (4.4)$$

Since the autocorrelation matrix of the input signal generally isn't known in the FxLMS algorithm, one must use another way of finding the optimal step size. These two articles, [49] and [50], derive an expression for the optimal step size on the following form.

$$\mu_{max} = \frac{2}{\|s\|^2 \sigma_x^2 (L + \frac{2}{B_w} D_{eq})} \quad (4.5)$$

In Equation 4.5,  $s$  is the impulse response of the secondary path, while  $\|s\|^2$  is its coefficients euclidean norm.  $\sigma_x^2$  is the power of the input signal,  $L$  is the length of the adaptive filter and  $D_{eq}$  is a parameter called the equivalent delay of the secondary path,  $D_{eq}$  is calculated like this.

$$D_{eq} = \frac{s^T \Psi s}{\|s\|^2} \quad (4.6)$$

If  $Q$  is the length of the secondary path impulse response, then  $\Psi$  is written like a diagonal matrix on the form.

$$\Psi = \begin{bmatrix} 0 & 0 & 0 & \dots & 0 \\ 0 & 1 & 0 & \dots & 0 \\ 0 & 0 & 2 & \dots & 0 \\ \vdots & \vdots & \vdots & \ddots & \vdots \\ 0 & 0 & 0 & \dots & Q-1 \end{bmatrix} \quad (4.7)$$

Note that including the equivalent delay of the secondary path,  $D_{eq}$ , is to make the optimal step size robust towards delays in the secondary path that are not pure time delays. The normalised bandwidth of the reference signal has also shown to affect the optimal step size, seen in [51]; including the variable in the equation.

## Estimation of Propagation Paths

The impulse response of the propagation path can be measured using different methods. If there is only one microphone available, creating an impulse at the source - for example, by cracking a balloon or by shooting blanks - before measuring the response with a sound receiver at the desired area of silence, is one way to estimate the impulse response. Another option, as mentioned in Chapter 2.1, is to play white noise from a loudspeaker and measure it at the area where the cancellation is wanted - After that, using the LMS algorithm to estimate the coefficients of the impulse response.

### 4.3 Proposed Solution

On improving the convergence rate of the FxLMS algorithm, the proposed solution is to emulate the setup shown in Figure 4.1, using the weight update from Equation 4.3. In other words, to apply the Normalised Subband Adaptive Filtering technique to the Filtered-X Least Mean Square algorithm.

A simulation setup in MATLAB should be made to test the hypothesis; where highly correlated input signals are used, and convergence behaviour is compared between the original FxLMS algorithm and the NSAF FxLMS algorithm with different amounts of subbands.

Ideally, input signals should be gathered from real noise sources and impulse responses created based on the actual propagation path. If such solutions are not feasible, correlated noise can be created using autoregressive signals, and one can generate impulse responses by designing filters based on typical properties of such propagation paths.

Signals with different characteristics should be used, and the outcome of the algorithms should be compared a certain number of times to exclude coincidences. The comparisons should also be made under unbiased circumstances, such as similar step sizes. At the same time, it should also be investigated whether the proposed step sizes are near-optimal for both algorithms.



## Chapter 5

# Experimental Evaluation

As mentioned in Chapter 3, using a MATLAB simulation setup was the approach taken for testing the hypothesis that subband adaptive filtering would improve the convergence time of the FxLMS algorithm. Note that the configuration used was a single-input single-output system with no feedback from the secondary path to the reference sensor. The undersigned travelled to the oil rig *Johan Sverdrup* for an overall view of the noise areas where sound attenuation was desirable. Measurements of noise levels, along with the recording of sound signals from different noise sources, also took place on the platform.

### 5.1 Experimental Setup and Data Set

An illustration of the simulation setup used for the NSAF FxLMS algorithm can be seen in Figure 4.1. Unfortunately, the noise recordings taken at *Johan Sverdrup* were not of good enough quality to be used in the simulation setup, due to interference from other noise sources; this caused the noise signals to appear as white noise. The sheer magnitude of noise sources also meant that it would be impossible to find the real propagation paths.

These issues caused for a completely simulated setup, due to the lack of real-world data, it became necessary to fabricate both the input signal and the impulse responses.

#### 5.1.1 Construction of Data

It was created different AR(2) signals to mimic the spectral features of the noise of a conventional rotary engine. Autoregressive (AR) signals are signals where the current sample correlates in some way to previous samples. Two AR(2) signals that

were used in the simulations were  $x(n) = 0.7x(n-1) - 0.3x(n-2) + w(n)$  and  $x(n) = -0.7x(n-1) - 0.2x(n-2) + w(n)$ . The first autoregressive signal resembles a low frequency dominated noise source, while the other one is a more high frequent one. Making an autoregressive signal can be done in MATLAB with the following code.

---

```
u = randn(T,1);           % White noise signal, size T x 1 and variance 1.
ARcoeffs = [1 -0.7 0.3]; % Autoregressive coefficients
x = filter(1,ARcoeffs,u); % AR-signal
```

---

Figure 5.1 shows the power spectral density of the AR-signal above, which is dominated by lower frequencies.

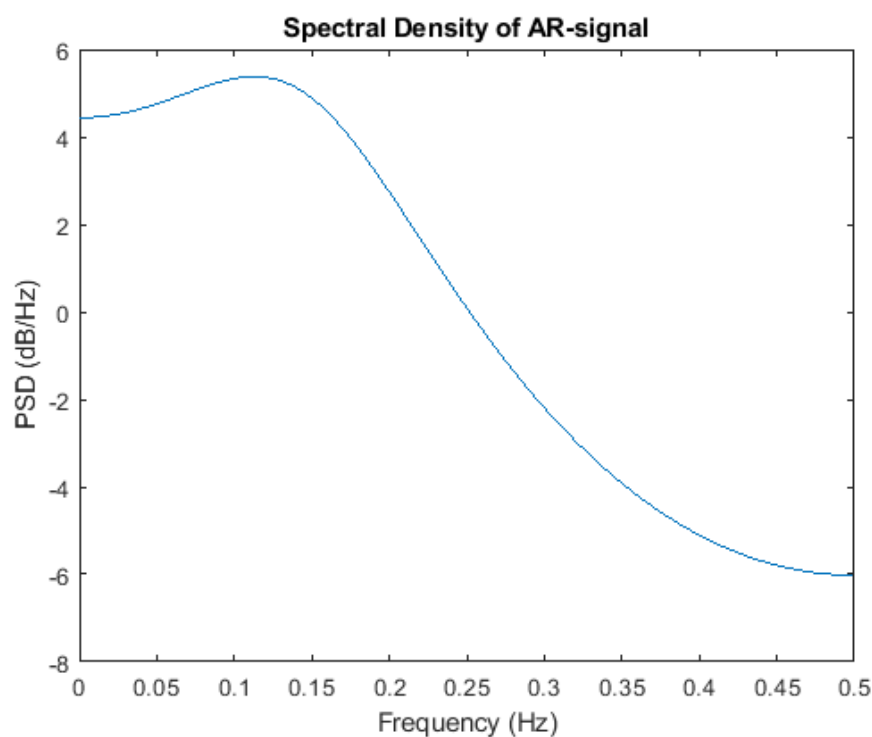

**Figure 5.1:** Autoregressive power spectral density estimate — Yule-Walker method[52]

### Impulse responses

In MATLAB, there are several ways to construct an impulse response. In this experiment, two different approaches were used. The first procedure, inspired by this MATLAB example, [53], uses the `fdesign.bandpass()` function in MATLAB. This function lets the user adjust many features, such as filter order, stopband attenuation, upper and lower band edge etc. as seen in the code below.

---

```

Fs      = 44100; % Sampling rate
N       = 800;  % Number of filter weights
Flow    = 500;  % Lower band-edge
Fhigh   = 15000; % Upper band-edge
delayS  = 7;    % Time Delay (samples)
Ast     = 10;   % Stopband Attenuation
Nfilt   = 20;   % Filter order

```

---

Not knowing how a real-world impulse response would look, a minor investigation and a bit of speculation were needed. This article, [54], mentions how the length of the impulse response can affect the convergence speed of the algorithm. An impulse response derived from measurements made in an active noise control system in a duct is also present in the article. The response flattens out at just over 100 samples, and that was quite hard to achieve using the MATLAB function `fdesign.bandpass()`. As Figure 5.2 shows, the impulse responses created needs a lot more samples to settle down, even if the passband area is wide, and the stopband attenuation is quite low.

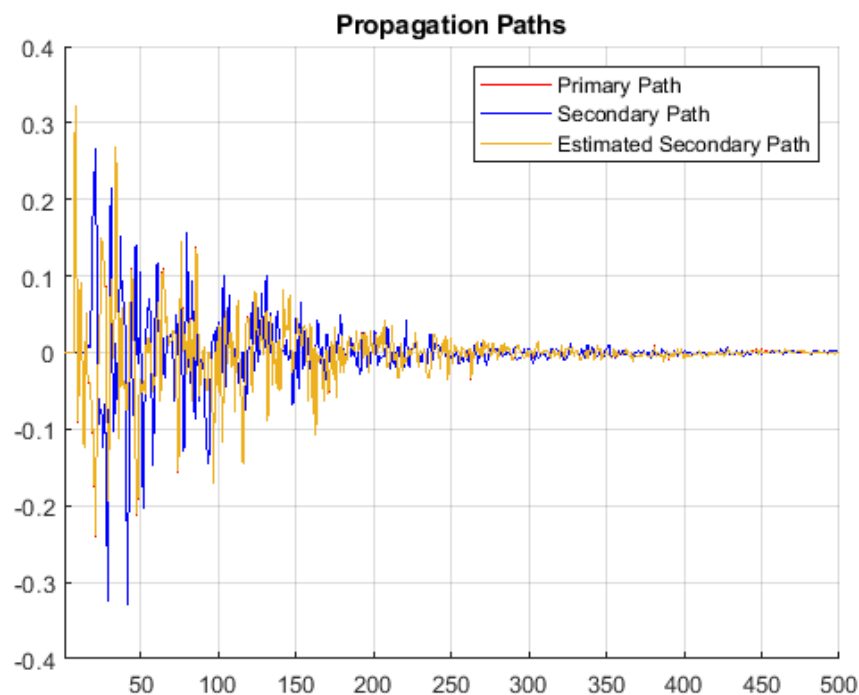

**Figure 5.2:** Impulse responses of the primary and secondary path. The estimate of the secondary path, which was estimated using the NLMS method is also shown.

In the beginning, the impulse responses were even longer because of a lower upper band limit. Under these conditions, the system - especially with the low-frequency AR-signal - struggled to become stable if the chosen step-size wasn't too small. Comparing the NSAF FxLMS and the normal FxLMS under these circumstances required a lot of processing

power and time since the step-size had to be so small for the algorithm to converge. The long convergence time says something about the importance of a short impulse response. Since such impulse responses have great difficulty in converging, they are unlikely to be representative of a real-world system. Therefore, using an elliptic lowpass filter, a shorter impulse response was made. The MATLAB function *ellip()* helped create the filter coefficients for the transfer function, while *impz()* assisted in making the impulse response. The code below shows how one can make an impulse response in MATLAB using these functions.

---

```
%% Secondary Path

pbf = 0.6; % Passband frequency
sba = 10; % Stop Band Attenuation
pbr = 0.5; % Passband ripple
delayS = 7; % Time Delay (samples)

% Finding parameters for transfer function
[b,a] = ellip(10,pbr,sba,pbf);
% Creating the impulse response
S = impz(b,a,N);
% Adding delay to the impulse response
S = [zeros(delayS,1); S(1:end-delayS)];
```

---

It was a lot easier to create a short response using this method. Note that this example normalises the passband frequency, and 0.6 is equivalent to about 13 kHz with a sampling rate of 44.1 kHz.

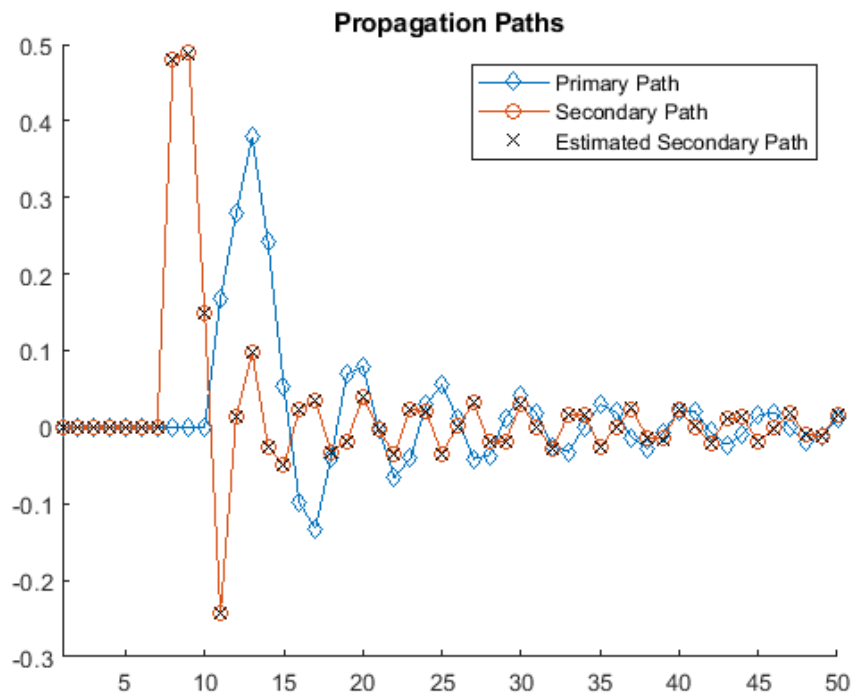

**Figure 5.3:** Impulse responses using the *ellip()* method in MATLAB.

Figure 5.3 shows the first 50 samples of the impulse responses of the propagation paths using the *ellip()* function. The impulse response coefficients are zero in the beginning, this is because of the time delay when the signal travels from the reference sensor through the different propagation paths to the error sensor. The plot also shows that the secondary path delay is shorter than the primary path delay, due to the principle of causality; this is necessary. In a case where the delay of the secondary path was longer than the primary path, it would be impossible to estimate random noise.

### 5.1.2 Algorithm

The NSAF FxLMS algorithm is built on the normalised FxLMS algorithm, only differing in that both the filtered reference signal and the error signal is split into  $N$  subbands, see Equation 4.3. The foundation of the algorithm, which is the NLMS algorithm, is thoroughly derived in Chapter 2.2. The snippet code below shows the central part of the NSAF FxLMS algorithm.

---

```

for n = 1:T
    X = [x(n) X(1:end-1)];
    xm(n) = Shat*X';
    Xm = [xm(n) Xm(1:end-1)];
    y(n) = h(n,:)*X';
    Y = [y(n) Y(1:end-1)];
    ym(n) = Y*S;
    Ym = [ym(n) Ym(1:end-1)];
    D = [d(n) D(1:end-1)];
    E = D - Ym;
    e(n) = d(n)-ym(n);

    % Subband Filtering of filtered-X and error signal
    sgm = zeros(1,M);
    for i = 1:N
        Xi(1,:,i) = conv(Xm,f(:,i),'same');
        Ei(1,:,i) = conv(E,f(:,i),'same');
        sgm = sgm + Xi(1,:,i)*Ei(1,1,i)/(Xi(1,:,i)*Xi(1,:,i)');
    end

    % Weight update
    h(n+1,:) = h(n,:) + mu_max*sgm;
end

```

---

Note that  $xm(n)$  and  $ym(n)$  represents, respectively,  $x'(n)$  and  $y'(n)$ , from Figure 4.1. All signals are split up into arrays of length  $M$ , which also is the length of the adaptive filter. Filling up every array with  $k$  samples for each iteration, where the  $k$  new samples come in at the beginning, and the rest of the array is moved  $k$  places towards the end; meaning that  $k$  samples go out in the other end. In this case  $k = 1$ , for simplicity. It

should also be pointed out that the subbands are not down-sampled in this example, even though down-sampling without loss of information is achievable when subband filtering.

## 5.2 Experimental Results

As expected, a higher number of subbands increased the convergence rate of the FxLMS algorithm. In Figure 5.4, you can see the original noise that would arrive at the error sensor if no ANC had been implemented,  $d(n)$ , the anti-noise,  $ym(n)$ , and error signal  $e(n)$ . The input signal is, in this case, the AR(2)-signal  $x(n) = 0.7x(n-1) - 0.3x(n-2) + w(n)$ , and is exactly the same for all four cases. The figure also shows that the subband filtering of the filtered input signal and the error signal has a great effect when it comes to improving the convergence rate for a highly correlated input signal.

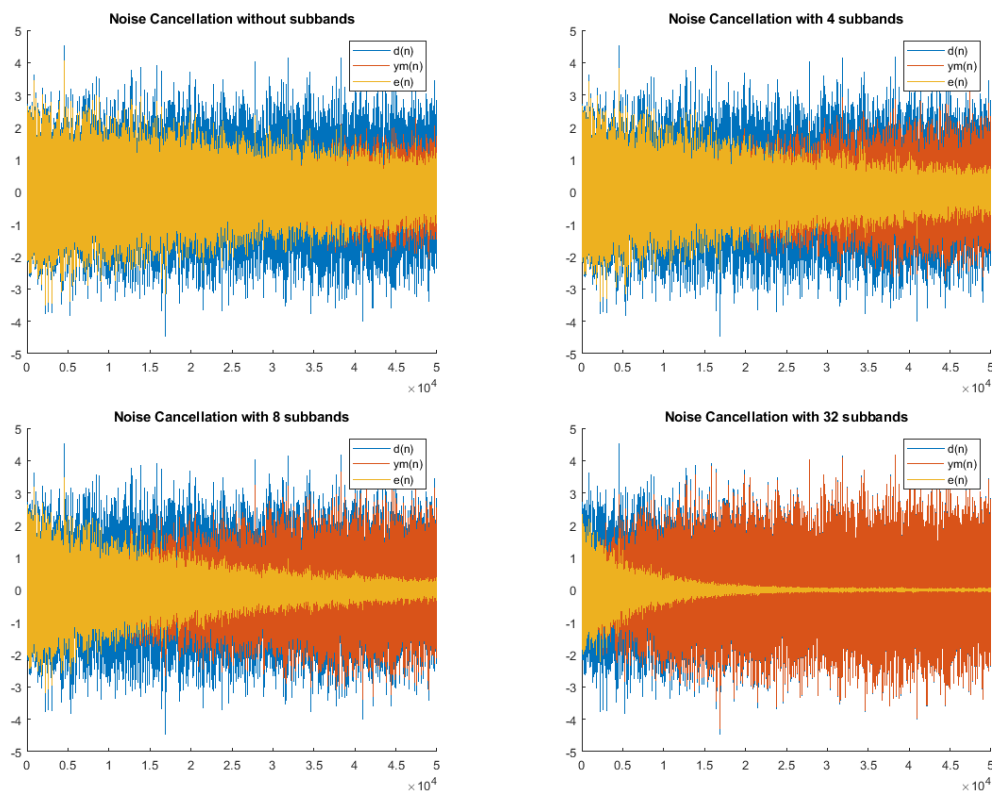

**Figure 5.4:** A comparison of the NSAF FxLMS algorithm using 1,4,8 and 32 subbands, respectively.

In Figure 5.4, it appears that it is not only the convergence rate that improves but also the steady-state properties. Given enough samples, all methods converge towards the same solution, which is illustrated in Figure 5.5; showing the total reduction of energy in a signal, with the same AR-coefficients, using 4, 8, 16 and 32 subbands. To remove

noise from curves, a mean filter of the form  $\underline{h} = \frac{1}{N}[h_0, h_1, \dots, h_{N-1}]$  was used, in this case  $N = 2000$ . Thus, not including the first  $N$  samples (out of 200.000).

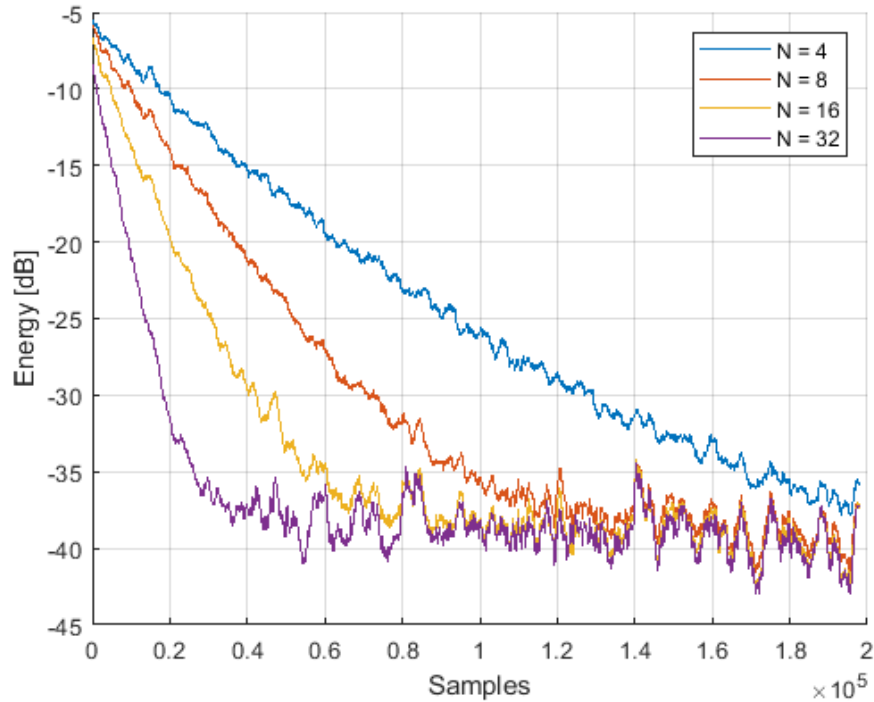

**Figure 5.5:** Convergence behaviour of the same NSAF FxLMS algorithm using the same input signal, but a different amount of subbands.

As one case is not enough for confirming the hypothesis, Monte Carlo simulations for comparing multiple simulations at once gave more explicit evidence that the subband filtering reduced the convergence time. In the Monte Carlo simulations, fifty different input signals, again with the same AR-coefficients, were presented to the NSAF FxLMS algorithms. The mean of the energy in the various input samples was calculated, using different amounts of subbands. See Figure 5.6. Again, it is shown that the convergence speed increases along with the number of subbands.

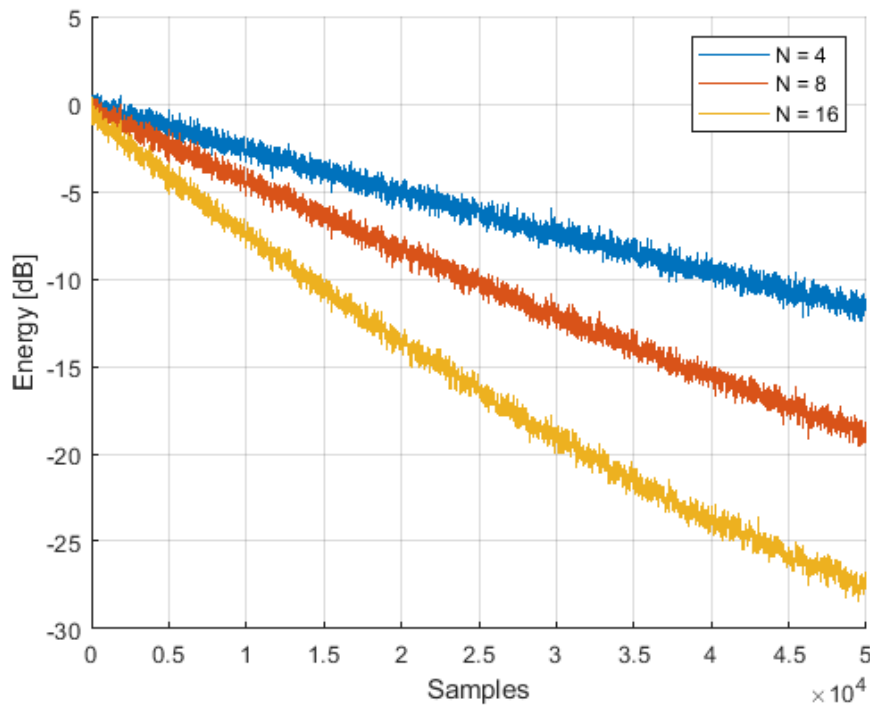
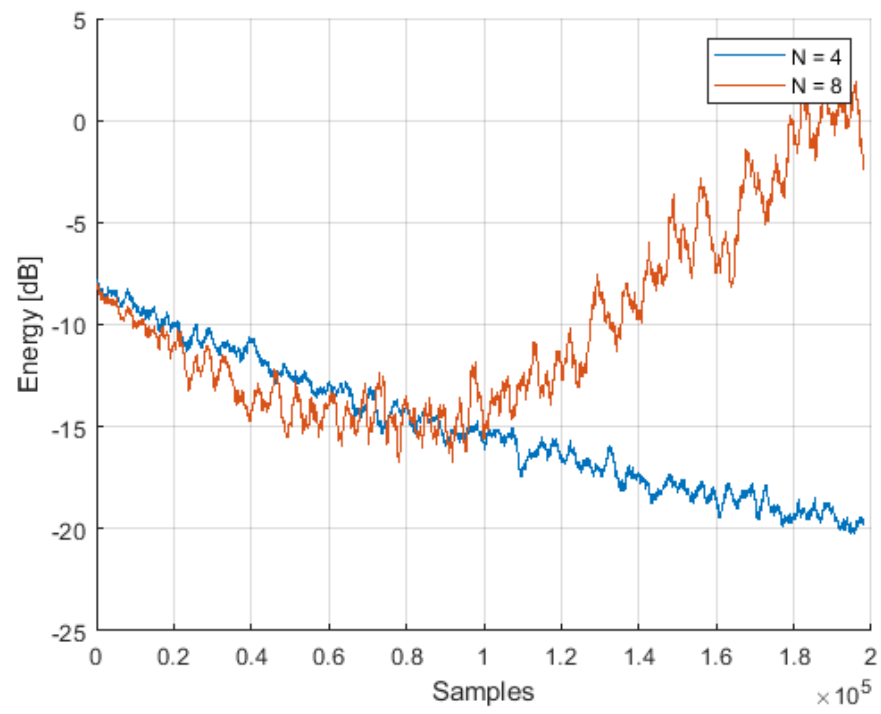

**Figure 5.6:** Monte Carlo simulation of the first 50,000 samples of the mean of the energy of the error signal, fifty different input signals were used, and the performance with 4, 8 and 16 subbands were compared.

As mentioned, the NSAF FxLMS algorithm was also tested with a more high frequency dominated AR(2) signal,  $x(n) = -0.7x(n-1) - 0.2x(n-2) + w(n)$ ; this gave similar results to those achieved with a low frequency dominated signal.

It was discovered that there was a lower threshold for a system to become unstable if the signals were divided into many subbands, than if they were split into a smaller number. This shows that using the same step size for all methods may not be fair, as suggested in Chapter 4. After some experimentation, it was concluded that the step size did not have to be reduced much for the system to be stable; thus, the convergence properties were still much better for systems with many subbands. Figure 5.7 shows an example of a system with eight subbands becoming unstable with the same input signal as the stable system using 4 subbands.





**Figure 5.7:** NSAF FxLMS with 4 and 8 subbands, notice how the system with eight subbands is becoming unstable.



# Chapter 6

## Discussion

### 6.1 Implementation of Active Noise Control in Offshore Environments

Since a well-functioning active noise control system is such an excellent tool for attenuating low-frequency noise, it could be a great supplement to a passive noise control system, which performs better for high-frequency noise. Especially since many workers suffer from hearing damage because of exposure to low-frequency noise[34].

Unfortunately, both literature and experiments have shown that ANC is not a one size fits all solution to noise problems. Many bricks have to be in place before you can implement such a system. One of the deciding factors for the possibility to achieve a well-functioning ANC setup is the desired area of sound attenuation. Small airtight cavities have proven to be optimal conditions for ANC, typically found in headsets and hearing protection.

For larger open areas, there are even more factors that come in to play. One has to ask if there is a need for noise cancellation throughout the room or if a small area of the room is enough. To reduce noise in an entire room, it is necessary to obtain a reasonable estimate of the acoustic pressure using virtual sensing. Virtual sensing performance is not only affected by the size of the cavity but also by the shape and the materials of the surrounding structure. As mentioned in Chapter 3, using a combination of structural vibration sensors and microphones, one can obtain a reasonable estimate of the acoustic pressure given the right conditions. Note that even though they produced a reasonable estimate of the acoustic pressure in [41] and reduced the total acoustic potential energy, there was still some parts of the room where noise levels increased.

Another critical factor is the position of the noise source and how one can position the secondary source relative to it. Optimally the noise source should be placed outside the cavity in a way where the sound propagates in one direction. Unfortunately, this is rarely the case for those areas of an oil platform where noise reduction is necessary. Noise sources within the room are usually the reason why sound levels become so high. In such cases, one should place the source at one end of the room so that the sound propagates a specific direction, preferably in a recess. If set correctly, an alternative could be to create a noise barrier like the one described in [44].

One should direct the secondary source towards the quiet zone. At the same time, it should be possible to record and process the input signal so that the anti-noise reaches the quiet area before the original noise, thus satisfying the principle of causality.

In industrial environments offshore, there are often many sources of noise in the same room; this increases the complexity considerably as it will be challenging to get accurate measurements from the reference sensor and the error sensor. The increased complexity applies to both global noise control and control of small areas within the room.

Controlling smaller areas of a room has proven to be significantly more manageable than silencing the entire room. There are practical examples of successful implementations of this both in the automotive industry and the aerospace industry. But in these examples, the noise source is placed outside of the cavity, and one can gather a priori knowledge about the noise characteristics using a rotational speed sensor. Another essential factor that determines the probability of succeeding in such a setup is whether the area to be silenced is static or dynamic. To attenuate sound around the ears of a moving person, one would need a combination of head-tracking, sound steering, dynamic virtual sensing and an ever-changing propagation path (both primary and secondary). C. Hansen described in, [18], that proper attenuation levels only can be expected in an area that is one-tenth of the wavelength of the signal to be attenuated. In other words, these technologies have to work very well to achieve good results.

A more reliable system is one where the quiet area is static, typically around the ears of a seated person. No head tracking is required, and both the propagation and the virtual sensing can be estimated and tested before putting it to use. Another thing that affects its performance is the characteristics of the input signal.

Both simulations and previous research have shown that the properties of the input signal are essential in regards to the convergence speed of the algorithm. The standard

FxLMS algorithm struggles with poor convergence behaviour when the input signal is highly correlated. A random white Gaussian noise signal with low eigenvalue spread converges significantly faster than coloured noise with a large eigenvalue spread. The experiments have shown that the use of subband adaptive filtering can significantly affect the convergence speed of a coloured input signal. It's not just whether the input signal is coloured or not that matters; the colour, which is dependent on the dominating frequencies of the input signal, is also crucial. Since it is hard to control a high-frequency input signal using ANC, a better option would be passive noise control when possible.

Other requirements are set for the input signal based on whether or not the principle of causality is fulfilled. For a non-causal system, a highly correlated input signal is desirable as a feedback system will be the only sensible option.

Another important note to make is that the way from an experimental setup in the laboratory to practical implementation is long. It is a hard task to account for all the variables that will play a part in the finished product, and the conditions of experimental setups are often optimised to prove a hypothesis, like the use of an anechoic chamber in [44]. Therefore, the results shown in practical implementations should be emphasised to a greater extent than in experimental ones.



## Chapter 7

# Conclusion and Future Directions

### 7.1 Conclusion

This thesis should provide a clear overview of the circumstances in which one can expect well-functioning active noise control. Along with providing an overall picture of what ANC can be used for, it was asked whether active noise control could be utilised to solve two specific issues; controlling noise from the source and creating a quiet area within a noisy room.

A combination of passive and active noise cancelling has shown promising results in creating a sound barrier in one direction from the source, although under suitable conditions. It is uncertain if applying this in multiple directions is a feasible option. So to cancel noise from the source, positioning the noise source in one side of the room is a requirement, and there should be available space for establishing a passive barrier and loudspeakers at the diffraction edges. Besides, suitable properties for both the input signal and the propagation paths are needed for adequate ANC performance.

For creating a noise-free area within the room, reducing noise around the ears of seated people, i.e. a static option, is the most reasonable alternative. A dynamic option, reducing noise around moving people, would require multiple advanced technologies to work smoothly, all at the same time. Another alternative is to reduce the total potential acoustical energy in the room; no research was found to indicate that this can be practised on larger cavities than a mid-sized car, making this option unobtainable to the places visited at the platform based on current literature.

In general, most rooms where ANC was requested to be implemented were large and contained many sources of noise; these are features that make global ANC unsuitable. At the same time, noise is mostly white in those areas, exposing workers to the same

amount of all frequencies. In the best-case scenario, one could expect an attenuation level of 10-20 dB for frequencies below 500 Hz. To no longer require hearing protection, it will be necessary to attenuate noise for the entire frequency spectrum, which does not seem possible with today's technology. Since hearing protection is a requirement anyway, one should take into account that active noise control has a much more significant effect in the hearing protection itself than out in the open; making that the best alternative for such environments.

Regarding active noise control in duct systems, it should undoubtedly be considered as an alternative, especially in cases where the noise from the duct is a significant part of the total noise.

### **NSAF FxLMS**

If you look at the results, there is no doubt that the subband filtering of the reference and error signal significantly increases the convergence rate of FxLMS. The convergence properties are also improved based on how many subbands one uses, improving more as the amount increases.

## **7.2 Future Work**

In the future, it is recommended to continue to invest further in active noise cancelling ear protectors. Based on second-hand information, workers are experiencing slight discomfort and choosing not to wear the existing solution, which could be an area to improve—at the same time, educating workers of the long term risks related to low-frequency noise exposure.

On utilising global ANC for offshore use, one should analyse the areas where high noise levels are a problem and see if it meets the criteria for implementation. As mentioned, there are also third-party operators involved in the implementation of ANC in the automotive industry, which it is advisable to inquire about specific cases where the prior work has been done.

Concerning the NSAF FxLMS algorithm, further work may be to compare the computational power required relative to the normal FxLMS and optimise it.



# List of Figures

1.1	A sound shower, viewed at the Oslo Airport, Gardermoen[14]	6
2.1	An illustration of the cancellation of sound pressure waves[20].	11
2.2	Interference pattern[21]	12
2.3	A block diagram of the FxLMS algorithm[23].	14
2.4	An impulse response	17
2.5	Block diagram of the Normalized Least Mean Square algorithm.	18
2.6	The NLMS algorithm where the secondary path, $S(z)$ , is included	20
2.7	The FxNLMS filters the input signal with an estimate of the secondary path.	21
2.8	Block diagram of FxNLMS with feedback from loudspeaker to reference sensor[25].	22
2.9	Estimate of feedback filter to compensate for the real feedback.	23
2.10	Power spectrum of white noise split into 16 subbands using ELT (Extended Lapped Transforms) and Welch's method for the averaged windowed periodogram.	24
3.1	Illustration of a duct system	30
4.1	Illustration of the NSAF FxNLMS algorithm	34
5.1	Autoregressive power spectral density estimate — Yule-Walker method[52]	38
5.2	Impulse responses of the primary and secondary path. The estimate of the secondary path, which was estimated using the NLMS method is also shown.	39
5.3	Impulse responses using the <i>ellip()</i> method in MATLAB.	40
5.4	A comparison of the NSAF FxLMS algorithm using 1,4,8 and 32 subbands, respectively.	42
5.5	Convergence behaviour of the same NSAF FxLMS algorithm using the same input signal, but a different amount of subbands.	43
5.6	Monte Carlo simulation of the first 50.000 samples of the mean of the energy of the error signal, fifty different input signals were used, and the performance with 4, 8 and 16 subbands were compared.	44
5.7	NSAF FxLMS with 4 an 8 subbands, notice how the system with eight subbands are becoming unstable.	45



MasterKode.7z 



# Bibliography

- [1] Equinor. About us - Equinor is a value based company. URL <https://www.equinor.com/en/about-us.html>. [Online: accessed 11-may-2020].
- [2] M. Rupp and A. H. Sayed. Robust fxlms algorithms with improved convergence performance. *IEEE Transactions on Speech and Audio Processing*, 6(1):78–85, 1998.
- [3] K. A. Lee and W. S. Gan. Improving convergence of the nlms algorithm using constrained subband updates. *IEEE Signal Processing Letters*, 11(9):736–739, 2004.
- [4] Berge, Torger. Alexander Kielland-ulykken, 2020. URL [https://snl.no/Alexander\\_Kielland-ulykken](https://snl.no/Alexander_Kielland-ulykken). [Online; accessed 14-May-2020].
- [5] Tollaksen, Tor Gunnar. Turøy-ulykken - Store Norske Leksikon, 2020. URL <https://snl.no/Tur\T1\oy-ulykken>. [Online; accessed 14-May-2020].
- [6] Composed group of independent parts.  
Helse, Arbeidsmiljø og Sikkerhet i Petroleumsvirksomheten. URL <https://www.regjeringen.no/contentassets/0a217a1b53a84a5b877bc526d67a5c5f/helse-arbeidsmiljo-og-sikkerhet-i-petroleumsvirksomheten.pdf>. [Online: accessed 15-may-2020].
- [7] Ketil Karlsen, Jakob Nærheim, Roy Erling Furre, Bodil Sophia Krohn, Berit Sørset, Øyvind Lauridsen, and Jeffery Samuelson.  
Forebygging av storulykker, arbeidsbetinget sykdom og skader i petroleumsvirksomheten. URL <https://www.forskningsradet.no/om-forskningsradet/publikasjoner/2014/forebygging-av-stor-ulykker.-arbeidsbetinget-sykdom-og-skader-i-petroleumsvirksomhet/>. [Online: accessed 15-may-2020].
- [8] Tone Morken, Magne Bråtveit, and Bente E. Moen. Rapportering av hørselsskader i norsk offshoreindustri 1992–2003. *Tidsskriftet, Den Norske Legeforening*, pages 3272–3274, 2005. ISSN 23. URL <https://tidsskriftet.no/2005/12/aktuelt/rapportering-av-horselsskader-i-norsk-offshoreindustri-1992-2003>.

- [9] Offshore Europe Journal. Silencing Offshore Noise Issues, 2016. URL [https://offshoreeuropejournal.com/news/fullstory.php/aid/8269/Silencing\\_offshore\\_noise\\_issues.html](https://offshoreeuropejournal.com/news/fullstory.php/aid/8269/Silencing_offshore_noise_issues.html). [Online; accessed 15-May-2020].
- [10] Centers for Disease and Prevention. What Noises Causes Hearing Loss, 2019. URL [https://www.cdc.gov/nceh/hearing\\_loss/what\\_noises\\_cause\\_hearing\\_loss.html](https://www.cdc.gov/nceh/hearing_loss/what_noises_cause_hearing_loss.html). [Online; accessed 15-May-2020].
- [11] Norwegian Oil and Gas. anbefalte retningslinjer for håndtering av hørselsskadelig støy, 2013. URL <https://www.norskoljeoggass.no/arbeidsliv/retningslinjer/helse-arbeidsmiljo-og-sikkerhet/arbeidsmiljo/114-anbefalte-retningslinjer-for-handtering-av-horselsskadelig-stoy/>. [Online; accessed 15-May-2020].
- [12] K. A. Lee and W. S. Gan. Improving convergence of the nlms algorithm using constrained subband updates. *IEEE Signal Processing Letters*, 11(9):736–739, 2004.
- [13] M. Rupp and A. H. Sayed. Robust fxlms algorithms with improved convergence performance. *IEEE Transactions on Speech and Audio Processing*, 6(1):78–85, 1998.
- [14] Rynander, Anna Karin. Soundshowers. URL <http://www.rynander.com/Soundshowers/soundshower.htm>. [Online; accessed 18-May-2020].
- [15] P. Premkumar D. Veeravasantarao, S. Ajay and B. Laxmidhar. Adaptive active noise control schemes for headset applications. *Proceedings of the 17th World Congress*, 2008.
- [16] Colin Hansen. Current and future industrial applications of active noise control. *Noise Control Engineering Journal - NOISE CONTR ENG J*, 53, 09 2005. doi: 10.3397/1.2839255.
- [17] R. Vicen-Bueno, A. Martinez-Leira, R. Gil-Pita, and M. Rosa-Zurera. Acoustic feedback reduction based on filtered-x lms and normalized filtered-x lms algorithms in digital hearing aids based on wola filterbank. In *2007 IEEE International Symposium on Intelligent Signal Processing*, pages 1–6, 2007.
- [18] Colin Hansen. Active noise control—from laboratory to industrial implementation. 01 1997.
- [19] Wikipedia contributors. Active noise control — Wikipedia, the free encyclopedia, 2020. URL [https://en.wikipedia.org/w/index.php?title=Active\\_noise\\_control&oldid=943127843](https://en.wikipedia.org/w/index.php?title=Active_noise_control&oldid=943127843). [Online; accessed 12-May-2020].

- [20] Wikimedia Commons. Active noise reduction, 2012. URL [https://commons.wikimedia.org/wiki/File:Active\\_Noise\\_Reduction.svg](https://commons.wikimedia.org/wiki/File:Active_Noise_Reduction.svg). [Online; accessed 02-March-2020].
- [21] GO-LAB. Wave interference, 2020. URL <https://www.golabz.eu/lab/wave-interference>. [Online; accessed 13-May-2020].
- [22] Physics Lab. Physics LAB: Introduction to Sound, 2020. URL [http://dev.physicslab.org/Document.aspx?doctype=3&filename=WavesSound\\_IntroSound.xml](http://dev.physicslab.org/Document.aspx?doctype=3&filename=WavesSound_IntroSound.xml). [Online; accessed 14-May-2020].
- [23] Raphael, Ranjit. FXLMS algorithm. URL [http://www.geocities.ws/ranjit\\_raphael/FXLMS.html](http://www.geocities.ws/ranjit_raphael/FXLMS.html). [Online; accessed 20-May-2020].
- [24] Erkan Kaymak, Mark Atherton, K Rotter, and B Millar. Active noise control at high frequencies. *13th International Congress on Sound and Vibration*, 1, 07 2006.
- [25] S. M. Kuo and D. R. Morgan. Active noise control: a tutorial review. *Proceedings of the IEEE*, 87(6):943–973, 1999.
- [26] Lichuan Liu, S. M. Kuo, and M. Zhou. Virtual sensing techniques and their applications. In *2009 International Conference on Networking, Sensing and Control*, pages 31–36, 2009.
- [27] Cornelis D. Petersen, Rufus Fraanje, Ben S. Cazzolato, Anthony C. Zander, and Colin H. Hansen. A kalman filter approach to virtual sensing for active noise control. *Mechanical Systems and Signal Processing*, 22(2):490 – 508, 2008. ISSN 0888-3270. doi: <https://doi.org/10.1016/j.ymssp.2007.06.007>. URL <http://www.sciencedirect.com/science/article/pii/S0888327007001069>.
- [28] GIK Acoustics. What Are Room Modes. URL <https://www.gikacoustics.com/what-are-room-modes/>. [Online; accessed 23-May-2020].
- [29] Wikipedia contributors. Similarities between wiener and lms — Wikipedia, the free encyclopedia, 2019. URL [https://en.wikipedia.org/w/index.php?title=Similarities\\_between\\_Wiener\\_and\\_LMS&oldid=910257367](https://en.wikipedia.org/w/index.php?title=Similarities_between_Wiener_and_LMS&oldid=910257367). [Online; accessed 24-May-2020].
- [30] C. Hansen and S. Snyder. *Active Control of Noise and Vibration*. Taylor & Francis, 1996. ISBN 9780419193906. URL <https://books.google.no/books?id=bdnKRePn0rkC>.
- [31] Kuan-Chun Chen, Cheng-Yuan Chang, and Sen M. Kuo. Active noise control in a duct to cancel broadband noise. *IOP Conference Series: Materials Science and*

- Engineering*, 237:012015, sep 2017. doi: 10.1088/1757-899x/237/1/012015. URL <https://doi.org/10.1088%2F1757-899x%2F237%2F1%2F012015>.
- [32] K.A. Lee, W.S. Gan, and S.M. Kuo. *Subband Adaptive Filtering: Theory and Implementation*. Wiley, 2009. ISBN 9780470745984. URL <https://books.google.no/books?id=mEjmYsdhp0QC>.
- [33] Sian Stevens Stuart Gallacher, Doyo Enki and Mark J. Bennett. An experimental model to measure the ability of headphones with active noise control to reduce patient's exposure to noise in an intensive care unit. *Intensive Care Med Exp*, 5, 2017. URL <https://www.ncbi.nlm.nih.gov/pmc/articles/PMC5645302/>.
- [34] Mahendra K V and V. Sridhar. Headset prototype design for industrial noise reduction using dsp. *Lecture Notes in Electrical Engineering*, 248:855–862, 09 2014. doi: 10.1007/978-81-322-1157-0\_86.
- [35] M. Guldenschuh, A. Sontacchi, M. Perkmann, and M. Opitz. Assessment of active noise cancelling headphones. In *2012 IEEE Second International Conference on Consumer Electronics - Berlin (ICCE-Berlin)*, pages 299–303, 2012.
- [36] Honeywell. Nye Muligheter med Moderne Hørselsvern. URL <https://www.norskoljeoggass.no/globalassets/dokumenter/drift/stoyprosjekt/frokostmoter/frokostmote-20121012-nye-muligheter-med-horselvern/hor-frokostmote-oktober-2012-holter.pdf>. [Online; accessed 27-February-2020].
- [37] Silentium, 2020. URL <https://www.silentium.com/home-appliances-case-study/>. [Online; accessed 19-February-2020].
- [38] S. Sadeghi, J. Poshtan, and M. H. Kahaei. The simulation and implementation of an active noise control system in a laboratory duct. In *2003 European Control Conference (ECC)*, pages 1252–1256, 2003.
- [39] Chaoqun Wu, Li Wan, Weijing Zhao, and Qi Zhou. Research on active control of axial flow fan noise using a novel and simplified duct system. In *2015 International Conference on Control, Automation and Information Sciences (ICCAIS)*, pages 153–158, 2015.
- [40] P. N. Samarasinghe, W. Zhang, and T. D. Abhayapala. Recent advances in active noise control inside automobile cabins: Toward quieter cars. *IEEE Signal Processing Magazine*, 33(6):61–73, 2016.
- [41] Amrita Puri, Subodh V. Modak, and Kshitij Gupta. Global active noise control in vibro-acoustic cavities using acoustic sensing. *Journal of Sound and Vibration*, 455: 256 – 274, 2019. ISSN 0022-460X. doi: <https://doi.org/10.1016/j.jsv.2019.05.005>.



- [42] Z.Su D. Halim, L.Cheng. Virtual sensors for active noise control in acoustic–structural coupled enclosures using structural sensing: Robust virtual sensor design. *Acoustical Society of America*, 129:1390–1399, 2011.
- [43] Sachau D. Kochan, K. and H. Breitbach. Robust active noise control in the loadmaster area of a military transport aircraft. *The Journal of the Acoustical Society of America*, 29:3011–3019, 2011. doi: <https://doi.org/10.1121/1.3562561>.
- [44] A. Omoto and K. Fujiwara. A study of an actively controlled noise barrier. *The Journal of the Acoustical Society of America*, 94(4):2173–2180, 1993. doi: 10.1121/1.407488.
- [45] Wikipedia contributors. Spatial correlation — Wikipedia, the free encyclopedia, 2020. URL [https://en.wikipedia.org/w/index.php?title=Spatial\\_correlation&oldid=943581347](https://en.wikipedia.org/w/index.php?title=Spatial_correlation&oldid=943581347). [Online; accessed 5-June-2020].
- [46] J. H. Husøy and M. S. E. Abadi. On the convergence speed of the normalized subband adaptive filter: Some new insights and interpretations. In *2017 International Symposium on Signals, Circuits and Systems (ISSCS)*, pages 1–4, 2017.
- [47] H. S. Malvar. Extended lapped transforms: properties, applications, and fast algorithms. *IEEE Transactions on Signal Processing*, 40(11):2703–2714, 1992.
- [48] Wikipedia contributors. Least mean squares filter — Wikipedia, the free encyclopedia, 2020. URL [https://en.wikipedia.org/w/index.php?title=Least\\_mean\\_squares\\_filter&oldid=941899198](https://en.wikipedia.org/w/index.php?title=Least_mean_squares_filter&oldid=941899198). [Online; accessed 27-May-2020].
- [49] Iman Tabatabaei Ardekani and Waleed H. Abdulla. Fxlms-based active noise control: A quick review. *Asia Pacific Signal and Information Processing Association*, 2011. URL [http://www.apsipa.org/proceedings\\_2011/pdf/APSIPA260.pdf](http://www.apsipa.org/proceedings_2011/pdf/APSIPA260.pdf).
- [50] Iman Tabatabaei Ardekani and Waleed H. Abdulla. Theoretical convergence analysis of fxlms algorithm. *Signal Processing*, 90(12), 2010.
- [51] On the convergence of real-time active noise control systems. *Signal Processing*, 91(5):1262 – 1274, 2011. ISSN 0165-1684. doi: <https://doi.org/10.1016/j.sigpro.2010.12.012>.
- [52] Matlab. Autoregressive power spectral density estimate — Yule-Walker method, . URL <https://se.mathworks.com/help/signal/ref/pyulear.html>. [Online; accessed 09-june-2020].
- [53] Matlab. Active Noise Control Using a Filtered-X LMS FIR Adaptive Filter, . URL <https://se.mathworks.com/help/audio/examples/>

active-noise-control-using-a-filtered-x-lms-fir-adaptive-filter.  
html. [Online; accessed 10-june-2020].

- [54] Young-Sup Lee, Yunseon Choi, and Jeakwan Kim. Length variation effect of the impulse response model of a secondary path in embedded control. *Journal of Sensors*, 2016. doi: <https://doi.org/10.1155/2016/8270121>.