

PAPER • OPEN ACCESS

Scalability and compatibility analyses of airborne wind technology for maritime transport

To cite this article: D A Domínguez Santana and I El-Thalji 2019 *IOP Conf. Ser.: Mater. Sci. Eng.* **700** 012064

View the [article online](#) for updates and enhancements.

Scalability and compatibility analyses of airborne wind technology for maritime transport

D A Domínguez Santana* and **I El-Thalji**

Department of Mechanical and Structural engineering and material science, University of Stavanger, Stavanger, Norway.

* Corresponding author: da.dominguezsantana@stud.uis.no

Abstract. Wind energy is a source freely available in the oceans. New developments in the wind industry are towards high altitude wind turbines, known as Airborne Wind Energy Systems. The airborne wind technology is rapidly developing with several different design concepts, e.g. Skysail, Makani, KiteMill. There are mainly two types of airborne wind technology: propulsion-supporting and electricity-generating. Electricity generating airborne technology is mainly used for land-based buildings and fixed offshore structures and with small-scale airborne turbines. Thus, the applications of this technology in the maritime industry are limited to ship propulsion-support only and no scalable airborne wind turbine is used on board of a vessel. Therefore, the objective of this study is to explore the application of electricity-generating airborne turbines on the board of a ship. The exploration is mainly to determine how scalable these turbines shall be to satisfy a ship's electricity needs and how compatible the design of these turbines can be with the ships design. . Therefore, a scalability analysis based on crosswind kite power model is applied to determine the technical requirements to scale up the existing airborne turbine to meet the electricity demand of a ship. Moreover, a compatibility analysis is applied to determine the technical interfaces and constrains between the airborne turbine configuration and the ship architecture. In this case, a commercial electricity-generating airborne turbine and a commercial floating storage unit are considered as part of the case study. The developed scalability model indicates that the traction force is the most critical design parameter to scale up a wind turbine. On the other hand, the developed compatibility model shows that there is a notorious complexity in merging airborne and ship technology due to their contexts. Consequently, this research appears to be relevant for both, the airborne technology industry and the maritime industry toward more innovative and cost- effective applications.

1. Introduction

Wind energy is a source freely available in the oceans. New developments in the wind industry are towards high altitude wind turbines, known as Airborne Wind Energy Systems (AWES). The Maritime industry is facing a challenge in reducing its dependence on fossil fuels. New established regulations to reduce the greenhouse gas (GHG) emissions by maritime transport force the sector stakeholders to adopt rigorous performance indicators and explore new technologies for propulsion and electricity generation on board of sea-going vessels.

Nowadays, there is a wide range of modern marine green technologies available on the market, used to improve the performance and sustainability of the ocean-going vessels. The Airborne Wind



Technology (AWT) as a mean to harvest wind in high altitudes have been explored since the seventies. It is nowadays when clear advantages have been shown and prototypes have been developed to prove that AWES are a feasible and competent solution to bare the worldwide emissions challenge [1]. There are two types of AWES, as shown in Figure 1. First, Ground- Gen AWES where the electrical energy is produced on the ground caused by a mechanical traction force [1]. Second, the Fly- Gen AWES where the electrical energy is generated on the aircraft and it is connected by an electrical cable to the ground station [1].

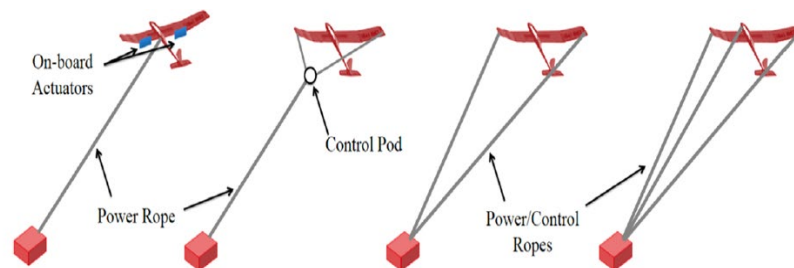

Figure 1. Fly-Gen AWES (left) and Ground- Gen AWES [1].

Currently, there are mainly two types of airborne wind technology: propulsion-supporting and electricity-generating. Few studies and patents related to AWES propulsion-supporting AWES, such as Sky Sails [2], Makani [3] and hybrid of kite and flettner-rotor systems [4]. Implementations on vessels with a specific operation location shall be performed to conclude in the contribution that this technology may provide.

The research and development that focuses on propulsion-support AWES is toward improving the design aspects such as take-off and landing techniques [5], [6], airfoil design like a rigid wing or soft kites, and Computational Fluid dynamics (CFD) and numerical modeling for power production [7]. However, there are no attempts yet to explore the electricity-generating AWES for maritime industry and specially for floating storage units, as shown in Table 1. Electricity generating AWES might have advantages over the propulsion support AWT as the produced energy can be shared for other purposes and not just for propulsion system. In fact, the floating storage unit has limited benefit from propulsion supporting AWT as it remains allocated at specific geographical site. Today, the electricity generating AWES is existing and is mainly explored and tested for land-based applications, e.g. Makani and Kitemill. The electricity- generating AWES can be still considered as small-scale systems that requires scaling up efforts to satisfy the electricity demand of floating storage units. Moreover, this technology interferes with the operational and physical (space, layout) architectures of the ship, where a compatibility and impact studies shall be performed.

Table 1. Airborne wind technologies and applications.

	Airborne Wind Technology	
	Propulsion supporting	Electricity-generating
Land Base	Not Valid	Kitemill Makani
Seagoing vessels	Sky Sails Makani	Not existing yet

Therefore, this study aims to develop the scalability and compatibility models of a rigid wing airborne technology energy to be used as a power plant in maritime transport i.e. floating storage unit. Therefore, a scalability analysis based on crosswind kite power model is applied to determine the technical requirements to scale up the existing airborne turbine to meet the electricity demand of a ship. Moreover, a compatibility analysis is applied to determine the technical interfaces and constrains between the

airborne turbine configuration and the ship architecture. In this case, a commercial electricity-generated airborne turbine and a commercial floating storage unit are considered as part of the case study.

The remainder of this article is organized into four sections. Section two corresponds to the theoretical background; section three presents the case study, scalability and compatibility analyses and results; section four discusses the critical issues before the main conclusions are drawn up.

2. Simplified crosswind power model

A kite's aerodynamic surface (airfoil) converts wind energy into motion of the kite. This motion may be converted into useful power by driving turbines on the kite or by pulling a load on the ground. Some developments have converted the kite motion into useful work pulling a load on the ground with a tether. To support the dimensioning and scaling up the prototype used for this research the following model is used. A kite is an aerodynamic vehicle restrained by a tether. Like an airplane, a kite produces lift (\bar{L}) and drag (\bar{D}_k) as it moves relative to the air. The kite is characterized by the reference area (A) of its wing, by its coefficient of lift (C_L) and by its lift- to- drag ratio [10].

In addition, the strength (S) of the kite must be sufficient to transfer the aerodynamic forces to the tether. This strength and the ratio of strength to weight (S/W) determine the necessary weight of the kite. The tether is characterized by length (R), tether cross- sectional area (A_T), working stress (σ), mass density (ρ_T), and coefficient of drag (CDT). The resulting drag of the tether is (\bar{D}_T). As the kite moves through the air, power may be generated by the tether traction force (\bar{T}) pulling a load at a velocity (\bar{V}_L) [9]. Calculation of the power generated by a cross- wind flight mode kite is simplified as follows. In this simple model the weight of the kite and the characteristics of the tether, including drag are neglected. The power generated is expressed in terms of A , C_L , the wind power density P_w , and the function F , representing the specific model. The final result is of the form:

$$P = P_w A C_L F \quad (1)$$

The magnitude of the relative wind velocity is VW and the air density ρ . Kites are commonly maneuvered by roll control. When one is flown to a position where the tether is parallel to the wind, the motion is directly crosswind. The speed through the air is increased above the wind speed, and the resulting power that may be generated is increased. The forces and velocities are shown in Figure 2.

The total drag \bar{D} is \bar{D}_k , \bar{V}_w and \bar{V}_c are the kite velocity, which is normal to the wind. Power is generated by pulling a load downwind at \bar{V}_L , so the effective wind speed at the kite is reduced to $\bar{V}_w - \bar{V}_L$. Since, \bar{T} is parallel to \bar{V}_w , and \bar{D}_k is parallel to \bar{V}_A , and since \bar{L} and \bar{D}_k are perpendicular and \bar{V}_w and \bar{V}_c are perpendicular, the velocities and forces form similar right triangles [9]. Thus,

$$V_c = (V_w - V_L)L/D_k \quad (2)$$

If L/D_k is large, \bar{V}_c and \bar{V}_A are approximately equal in magnitude so that

$$V_A = (V_w - V_L)L/D_k \quad (3)$$

The lift of the kite is given by

$$L = \frac{1}{2} \rho C_L A V_A^2 \quad (4)$$

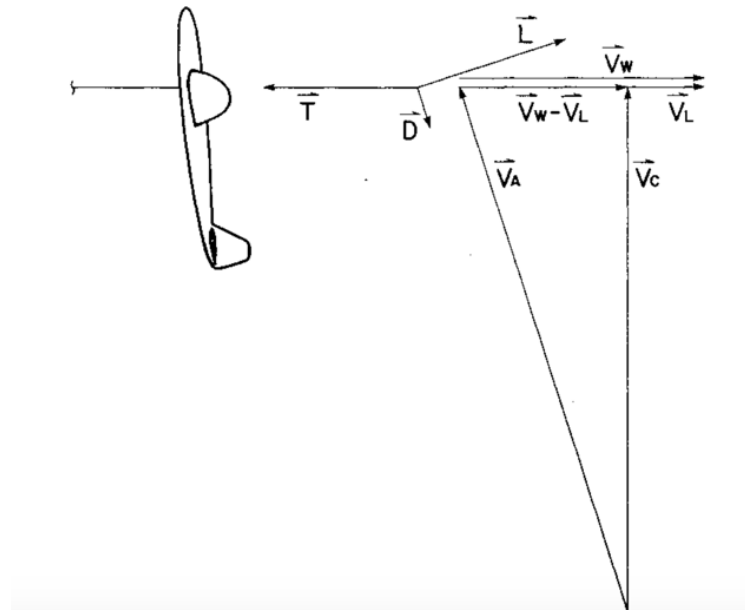

Figure 2. Aerodynamic forces on the AWE [9].

Which becomes

$$L = \frac{1}{2} \rho C_L A [(V_W - V_L) L / D_k]^2 \quad (5)$$

Since \vec{T} is colinear with \vec{V}_L , and the magnitude the power produced is

$$P = T V_L \quad (6)$$

However, the Lift and the Traction force are approximately of the same magnitude. The function F becomes, F_C ,

$$F_C = (L/D_k)^2 (V_L/V_W) (1 - V_L/V_W)^2 \quad (7)$$

The maximum value of F_C is

$$F_{Cmax} = 4/27 (L/D_k)^2 \quad (8)$$

Which occurs at

$$\frac{V_L}{V_W} = \frac{1}{3} \quad (9)$$

3. Scalability and compatibility analyses

The scalability concept refers to the ability of a system to increase the capacity or dimensions of its design parameters in order to supply or withstand a larger demand. A system is scalable when its design parameters increase the size of the system by keeping its performance and function and retaining all its desired properties without a corresponding increase in its internal complexity [8]. The compatibility concept refers to the ability of two system with different or same purpose to work together without interfering on their functions or performance. A system is compatible with other when its main characteristics or functions do not need to be altered [8]. If the system is scalable to a larger power demand, then the scaled-up AWES will be studied in order to be fit in an existing ship, therefore the compatibility of ship technology and AWET will be modelled.

The case to be studied is based on an AWES prototype of 30 Kw developed by one company in Norway and the Floating Storage Unit Njord Bravo, which operates in the North Sea in the Norwegian Njord field. The study consists of developing a model to scale-up the capacity of the AWES prototype

following the crosswind kite power model written by M. Lloyd. Once the design parameters are scaled-up, the compatibility of the new AWES with the FSU Njord Bravo will be studied. To do so two models are developed. The technical specifications of the AWES and the vessel have been provided by the owners of both systems.

3.1 Scalability analysis

First of all, based on the information provided by the crosswind kite power a scalability model is proposed in this section in pursuance of estimating the scalable design parameters of the AWES prototype so that it provides the power demand of the vessel. The model is proposed in Figure 3:

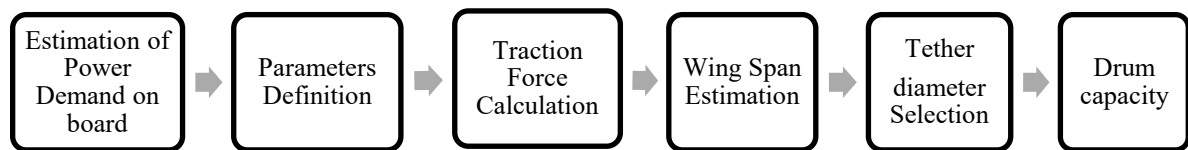

Figure 3. Steps of scalability analysis for AWT.

The model is divided into six steps, each of them is developed in order to achieve the desired AWES that should satisfy the power demand of the FSU Njord Bravo. In step 1, for this particular case, it is a good approach to assume that the power consumed onboard is around 60-70% of the total capacity of the main generator. Since a generator must not run more than 30 minutes at its maximum capacity. With this assumption, a safety margin of 30-40% is considered. The power demand onboard of the FSU Njord Bravo is 1222 kW. Due to the safety measure mentioned above, it is a safe approximation to consider the power output of the AWES as 1500 kW. In step 2, it is worth listing the assumptions considered to justify the value of some input parameters shown in table 2.

- Assumption 1: lift- to- drag ratio values for kite airfoils vary from 7 to 10, the most common values used for the AWES developers airfoil design are from 7 to 9, but in several design models value is 10 [15] & [26].
- Assumption 2: the most common value used for the lift coefficient is 1[10].
- Assumption 3: the optimal wind speed for kite power production from 4 to 12 m/s [11].
- Assumption 4: according to the crosswind kite power simplified model the load velocity is assumed to be one-third of the wind speed, so that $V_L = \frac{1}{3}V_w$ [10].
- Assumption 5: The motion of the kite and the vessel are neglected.

Table 2. Input design parameters.

Definition	Parameter	Value	Units
Lift- to- drag ratio	L/D_k	[7,10]	[-]
Lift coefficient of the kite	C_L	1	[-]
Atmospheric Air density	ρ	1.2	[kg/m ³]
Wind velocity	V_w	[4,12]	[m/s]
Load velocity of the tether	V_L	1/3 of V_w	[m/s]
Maximum theoretical power coefficient [7]	C_{pmax}	4/27	[-]
Tether length	R	[250-1200]	[m]
Power Output	P	1.5	[MW]

In step 3, the traction force is calculated by applying the equation (6), considering the power output of 1500 kW and the wind speed of 12 m/s. This wind speed is the most repeated wind velocity in the operation zone of the FSU Njord Bravo at 500 m. These inputs result in a traction force of 375000 N. So that for a power output 50 times bigger than the prototype, a traction force 50 times higher is required. Step 4, consists in the wingspan estimation. The wingspan is the distance from tip to tip of the wings. For this calculation, equation (3), equation (4) and equation (5) are implemented respectively. Moreover, the fly mode of the AWES is considered to have a circular path trajectory as a traditional HAWT. Thus, the following equation is taken:

$$A = \frac{\pi D^2}{4} \quad (10)$$

Consequently, different wingspan (D) have been calculated for several lift- to- drag ratios (L/D_k) used by the aviation industry. For a wind speed of 12 m/s, and a L/D_k of 8, the resultant wingspan is 14 m. It is twice bigger than the prototype of 30 Kw. The next step consists of the selection of the tether. It has been based on manufacturers of synthetic fiber tethers for offshore applications. The preferred manufacturer is *Lankhorst Offshore*. The selected diameter of the tether is 30 mm, which is able to withstand 380000 N for a length of 1200 m. The last step comprises the calculation of the drum capacity or how much tether the winch can allocate for the selected diameter. This calculation is based on DNV-GL Rules for classification and construction for loading gear on seagoing ships and offshore installation, section 8, C.4.4 and C.4.5. To add up, the AWES developer has the practice to assume that the winch drum diameter should be 40 times bigger than the tether diameter. Therefore, a winch of 1.2 meters of diameter can allocate 1523.47 m of tether, which is sufficient to reach wind fields between 500-1000 m of altitude.

3.2 Compatibility model

Firstly, in pursuance of assessing the compatibility of the AWES on board of the FSU Njord Bravo for electricity generation, it is worth to mention the context of the application, figures 4a and 4b show the framework of the airborne wind technology and the ship technology respectively.

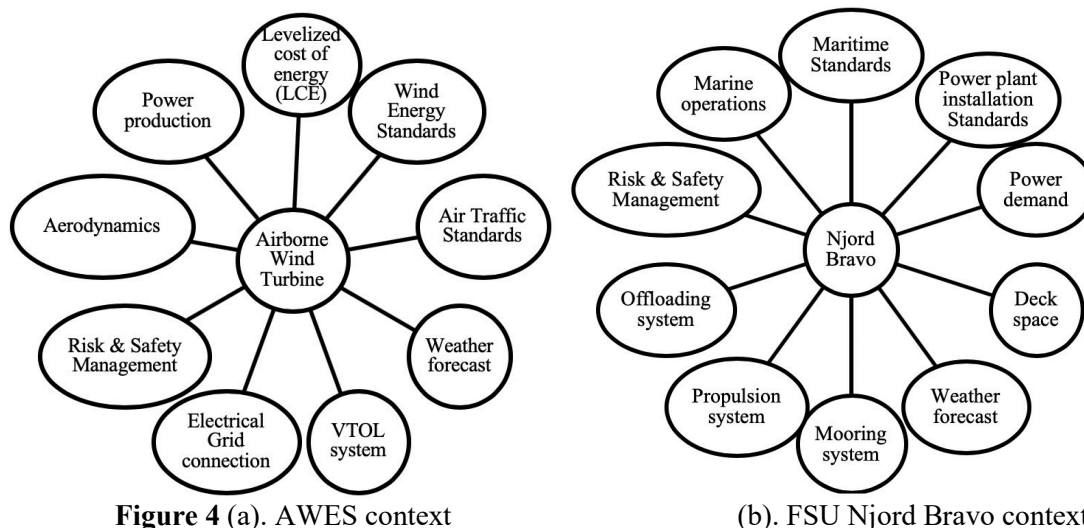

Figure 4 (a). AWES context

(b). FSU Njord Bravo context

The compatibility model is proposed (as illustrated in Figure 5) to check if the up-scaled AWES is compatible with the vessel where it will be installed on. It consists of three steps that have to comply with the standards and stability requirements of the vessel.



Figure 5. Steps of compatibility analysis for AWT.

On step 1, the dimensions and weight of every component of the system have to be estimated, so that the stability and operation of the vessel are not compromised at any time.

Table 3. Weight and Dimensions estimation.

Component	Weight [Kg]	Dimensions [m]
Generator	5205	1.79x1.33x0.97
Winch	8878.14	1x1.2
Rope/tether	947.78	30x1523.67
Aircraft	70-90	14x8
Take- off and landing platform	-	16x10

On step 2, the General Arrangement of the FSU Njord Bravo has been provided. It is appropriate to accommodate the winch and generator on the engine room of the vessel since it is already prepared according to standards to allocate this type of machinery. In terms of the tether and the aircraft, the Poop-deck is proposed for the installation of the equipment. On the last step, a new set up for the AWES onboard of the FSU Njord Bravo is proposed, as shown in Figure 6.

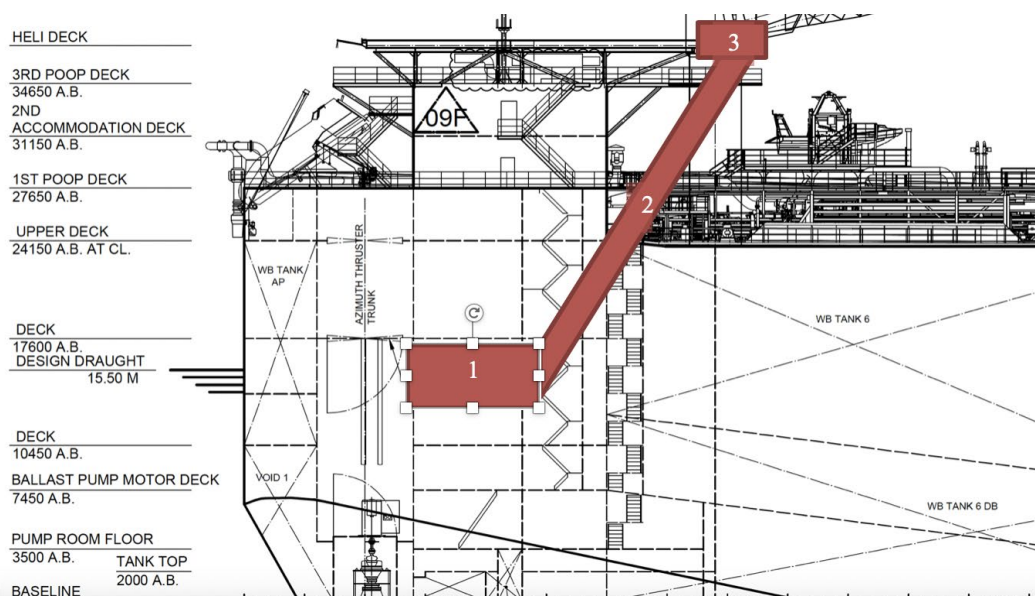

Figure 6. AWES set-up on FSU Njord Bravo, section 1 is the winch and generator; section 2 is the tether and the pipeline that contains it and section 3 is the aircraft and take-off and landing platform.

4. Discussion and conclusion

It is important to note that both models are established for the Technology Readiness Level 2 (Invention and research). Table 4 shows the comparison between the currently developed prototype of 30 kW and the up-scaled one.

Table 4. Comparison between 30 Kw and 1.5 Mw AWES.

Parameter	Current prototype	Upscaled Design	Unit
Wind speed	12	12	[m/s]
Reel speed	4	4	[m/s]
Power output	30	1500	[KW]
Traction force	7.5	375	[KN]
Wingspan	7.5	14	[m]
Tether Diameter	2	30	[mm]
Drum diameter	0.25	1.2	[m]

Regarding the compatibility model, the results conclude that there is the availability of space and weight in order to install the new system for electricity generation without compromising the stability, operation, and integrity of the vessel. In order to check if the wingspan obtained is sufficient in terms of aerodynamic efficiency, CFD analysis shall be performed. Lastly, the tether diameter and drum capacity were calculated based on manufacturers. Both parameters are related to each other by the traction force so that the higher the traction force the bigger the tether diameter should be. Getting a higher tether diameter implies a bigger drum capacity, which may affect the compatibility of the system with the ship. To add up, the bigger is the tether diameter the higher is the drag force. The drag force will reduce the crosswind power output and will increase the loading on the system. For future cases, a drag model for the tether shall be proposed.

On the other hand, the compatibility model is also reliable, it shows that structural changes shall be performed in order to install the AWES on board. These changes may affect the function of the vessel and the system. For example, the set-up onboard shall ensure good stability of the vessel, not overlap between operations on board, not excessive ship motions and the safety shall never be compromised. In the model, it is assumed that the flight mode of the kite is static and does not contribute to the propulsion or motions of the vessel. Although the mooring turret together with the DP system are in operation such that the vessel remains in position under strong wind and sea states, the AWES will tend to propel and move the vessel if the traction force is high enough to do so. Nevertheless, the FSU Njord Bravo presents a high potential to allocate the AWES as an electricity generator onboard. Overall, it can be concluded that AWT is scalable and compatible in size for floating storage units. It is vital to mention that this technology is in an early stage of development and the power supply for floating storage units is not as demanding as in other ships in the industry.

Essentially, the models might be applied to any crosswind airborne wind system and any commercial vessel. The main lessons learned of this study are:

- The traction force is the most critical design parameter for the scalability of the AWES. More complex crosswind kite power model accounting the tether drag shall be developed and studied for this case.
- It exists a big complexity merging the airborne wind technology, especially when it comes to the AWES motion and the vessel motion in terms of relative wind speed. Both dynamic and risk analysis shall be performed.

References

- [1] Antonello C, Andrea P, Rocco V and Marco F 2015 Airborne Wind Energy Systems: A review of technologies, *Renewable Sustainable Energy Rev.* **51** 1461-76.
- [2] SkySails, [Online]. Available: <https://www.skysails.info/en/>. [Accessed: 12.02.2019].
- [3] Makani [Online]. Available: <https://makanipower.com>. [Accessed: 12.02.2019].
- [4] Michael T, Paul G, Conor W, Alice B, Antonio F, Peter S and Ruth W 2013 Propulsive power contribution of a kite and a Flettner rotor on selected shipping routes, *Appl. Energy.* **113** 362-72.
- [5] Fagiano L and Schnez S 2017 On the take-off of airborne wind energy systems based on rigid wings, *Renewable Energy.* **107** 473-88.
- [6] Jonas K Paul W and Soeren S 2017 Modeling of an airborne wind energy system with a flexible model for the optimization of landing trajectories, *IFAC-PapersOnLine*, **50**(1) 11944-50.
- [7] Marcello D L, Romeu R, Ramiro S and Alexandre T 2018 The Betz Limit applied to Airborne Wind Energy, *Renewable Energy*, **127** 32-40.
- [8] Anthony S and Manuel FDO 2010 *Networked Graphics: building networked games and virtual environments*, Morgan Kaufmann Publishers, MA, USA
- [9] Loyd M L 1980 Crosswind Kite Power (for large-scale wind power production), *J. Energy.* **4**(3) 106.
- [10] Kitemill, [Online]. Available: <http://kitemill.com>. [Accessed: 01.02 2019].