

Questionnaire-based survey of experiences with the use of expanding PIN systems in mechanical joints



Ø. Karlsen^{*}, H.G. Lemu

Department of Mechanical and Structural Engineering and Materials Science, University of Stavanger, Stavanger, Norway

ARTICLE INFO

Keywords:

Expanding pins
Heavy equipment
Tear and wear
Downtime
Safety

ABSTRACT

In this paper, experiences with the use of expanding pins in mechanical joints in different equipment are investigated through a questionnaire-based survey, where six different sections are highlighted; Size of company, Company profile, Experience with expanding pins, Market and equipment, Pin source and Effects and consequences of applying expanding pin solutions. The responses on the survey came from 10 different countries, with the main segments being Offshore oil & gas, Maritime/ships and Construction/earth moving. In total 256 potential responders received the questionnaire, divided into 140 Norwegian based companies and 116 non-Norwegian. Expanding pin systems are clearly seen as technically better pin solutions which protect better both people and equipment, and the non-Norwegian companies are reporting better experiences with expanding pins, in general, compared to the Norwegians, and recognize more the importance of the economic effects of applying expanding pins, compared to standard cylindrical pins.

1. Introduction

Pins or bolts are involved in almost any mechanical joint, moveable or fixed, in order to transfer power or forces/reaction forces from one part to another. For heavy equipment and machinery like cranes, drilling equipment, dumpers etc., the most common pin solution would be of cylindrical type, with a specific length and a uniform diameter over the whole length, and often with a locking plate at the end. Such pins normally come with the equipment from the OEM (Original Equipment Manufacturer), and pin spare parts are normally delivered from the same OEM as a part of their business philosophy. The end-user of that equipment is often obliged to buy the OEM spare parts to maintain the equipment guarantee, and then often to a relative high price.

There are typically 4 ways of assembling mechanical components using pinned joints:

1) *Shrink fit*: a type of fit where an oversized pin is fitted by cooling the pin or by heating the support bore surface [1]. When the temperature of the assembled pin and bore reach to the same ambient temperature level either by expansion of the pin or contraction of the bore, an interface contact pressure between pin and support bore wall is produced. The contact pressure keeps the pin in its position during

service and operation and prevents any relative movements between the pin and the support, being axial, radial, or rotational.

- 2) *Press-fit*: in this case, an oversized pin is forced into the bore by an axial load and by that the necessary interference fit is produced. The contact pressure keeps the pin in its position during service and operation, like the case with shrink fitted pin, and is given by elastic modulus, interference fit level, solid shaft diameter, and hollow hub inner and outer diameters. Fig. 1 [1] shows a principle sketch of a press fit.
- 3) *Pin joint with locking plate*: in this joint a pin with a slightly smaller diameter than the bore is inserted and locked to the supports with locking plate to avoid rotation or axial displacement. The radial movements depend on the installation tolerance between pin and support. The tolerance level would typically depend on the OEM's preferences regarding the installation, operation/service, and retrieval processes. A very tight tolerance could be ideal for service and operation, but difficult or impossible for installation and retrieval.
- 4) *Pin joint with expanding pin technology*: this is a joint where an expanding type of pin system is introduced [2–4] which will typically have an installation tolerance or clearance as in 3), and then expands and locks to the bore wall much like as cases 1) and 2). The contact

^{*} Corresponding author.

E-mail address: oyvind.karlsen@uis.no (Ø. Karlsen).

pressure due to the interference fit between the pin and the supports prevents any relative movements.

When shrinking a pin into position by cooling (1) or forcing it to produce the interference fit (2), it may become complicated and expensive to remove it, if required. It cannot necessarily be done at site due to restrictions on heat/cold work, or hydraulic pressure limitations due to personal and equipment safety restriction. The most common pin solution for heavy equipment is, therefore, the standard cylindrical one with a slightly smaller diameter than the bore in the joint, which theoretically is easier to install and retrieve than the standard interference fit solutions, due to the installation tolerances on the pin diameter.

A pin lying loose in a joint will always move around during service and operation since its diameter is slightly smaller than the support bore diameter. Such movements of the pin in combination with load, vibrations and punches will create tear, wear and ovality in the bore, and possible wear of the pin depending on the steel quality, which again results in a bigger play and reduced contact area between pin and support. A reduced contact area will increase the contact pressure, and the risk of accelerating wear, although the surface might be hardened due to the previous plastic deformations, and increased risk of pin breakage.

Pin breakage or malfunction can have serious consequences, not only of mechanical and operational nature, but also injuries or fatal consequences for personnel. Ahmed and Gu [5] described failure modes, causes, consequences and prevention methods in an analysis of marine boilers, where bolt failures due to incorrect tightening torque or loose joints can ultimately result in personnel injuries. Such bolt and joint issues can also result in loose boiler or low steam pressure due to pressure loss, with fire and explosion as consequences. Major accidents onboard, or breakage of bolts in the rudder system, can lead to loss of control over the ship, collision and loss of personnel, cargo, and major negative impact on the marine environment, as happened with the infamous accident of the Exxon Valdez [6]. Haute and Pire [7] did a case study regarding maintenance intervals for MP-TP bolted connections for offshore windfarms. Due to the increasing size and number of bolts, maintenance has become a cost and health, safety and environment (HSE) issue that must be considered up against the risk of self-loosening of the installed bolts, which again is a serious risk. Corrosion of steel is often a great problem within a wide range of industries and activities, and liquids like drilling mud contain normally highly corrosive additives which negatively also affect the bolt connections. Many investigations are performed to develop corrosion inhibitors, as discussed in Akintola et al. [8].

The expanding pin system is more complex design-wise than a standard cylindrical pin design, but it has a range of advantages compared to the other solutions, like the pin shrink fitted by cooling, press-fit to interference and standard cylindrical solutions. This investigation will analyse the feedback and experiences from various stakeholders, who have different experiences and interests when it comes to expanding pin systems. Some of the typical interests of the relevant stakeholders considered in the study are listed below:

- **OEMs:** These produce and deliver complete systems (crane, vehicle, etc) often without having operational activities themselves and therefore not suffering the negative consequences regarding the choice of type of pins, apart from possible pre-installation issues, typically under controlled conditions. Their choice of pin types could be affected by requirements from their customers. Normally the OEMs would require their customers to buy spare part pins to maintain the product guarantee. Some OEMs are producing and delivering their own pin designs, and others are supplying from external producers, but according to OEM's requirements.
- **Sub-suppliers to OEMs:** These are supplying complete or part of the systems to the OEM, and the choice of pin types would typically be according to OEM's requirements.

- **Engineering companies:** These can design pin systems according to strict requirements from their customers or implement own design. Some engineering companies also run projects for their clients and could have more freedom when it comes to choosing pin systems, and some engineering companies are part of an OEM group.
- **End-users:** An end-user (of the OEM equipment) will always receive the equipment with the pins already installed, and normally with restrictions when it comes to changing pins. They are normally committed or obliged to buy the OEM's pin solution to maintain the equipment guarantee.
- **Service/repair/maintenance:** Such companies can be part of an OEM, or a freestanding company often with a certain level of liberty to propose pin type system.
- **Pin producers:** These would have their own pin design often with a general interest in reaching all possible decision makers at all stakeholders.

Upon analysing the feedback data from the above-listed stakeholders to the distributed questionnaire, the purpose of this study is to develop better understanding of the perception of the expanding pin system in the market, identifying its strength and weaknesses in order to optimize the design, develop effective market approach and improve procedures for installation, operation, maintenance and retrieval of pins and pin systems. In addition, the survey result will assist in new developments to satisfy needs in the market. The survey is part of a study on technical and economic consequences of using the expanding pin (i.e. type 4 joint in the above list) for heavy duty machinery.

2. Backgrounds and applications of expanding PIN system

Pins used in heavy machinery and industrial equipment have normally a smaller diameter than the support bore, but a higher strength and harder surface. Typical support materials can be high yield strength structural steel plate S355J2 (EN 10025), where J2 indicates -20 °C temperature impact test, or S420 (EN10025). The physical properties of both materials are given in Table 1. Steel grade S420, is a high strength weldable structure fine grain steel quality. It can reach high impact properties for certain grade variations even at temperatures as low as -50 °C.

2.1. Background

The pin is normally exposed to high loads, often oscillating, dynamic or exposed to shocks, and it serves as the critical connection element between different parts of the machine. The pin material is therefore normally of a higher strength steel grade than the supports, often of quality 42CrMo4 Q + H, 34CrNiMo6 Q + H or 30CrNiMo8 Q + H, 17-4 PH, and S165 M/1.4418, whose physical properties are given in Table 1 [11].

Table 1
Physical properties of pin and support materials for heavy machinery [9,10].

Steel grade	Yield strength, R _{p0.2} [MPa]	Tensile strength, R _m [MPa]	Valid diameter size range [mm]
S355 (EN 10025-2/-5)	355	470	40-80
S420 (EN10025 -2/-6)	360	520-680	63-80
42CrMo4 Q + H (EN10083)	650	900	≤ Ø100
34CrNiMo6 Q + H (EN10083)	800	1000	≤ Ø100
30CrNiMo8 Q + H (EN10083)	900	1100	≤ Ø100
S17-4 PH D1150/1.4542	725	930	-
S165 M/1.4418	700	900-1100	-

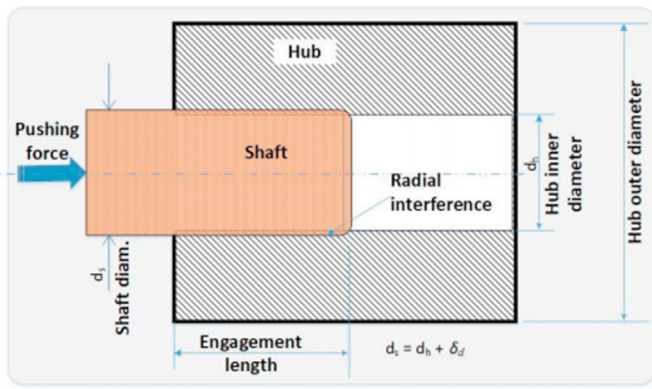

Fig. 1. Principle sketch of a press fit.

A standard pin would create a contact pressure with the support bore only because of the external load, and the contact surface would be less than 180°, depending on the installation tolerances, or diameter differences between the pin and the bore. An increased, or wider, tolerance would result in a reduced contact area and increased radial contact pressure as a result.

The contact stresses between the support bore with diameter $D_2 (= 2r_b)$ and pin with diameter $D_1 (= 2r_a)$ (Fig. 2) can be calculated by using

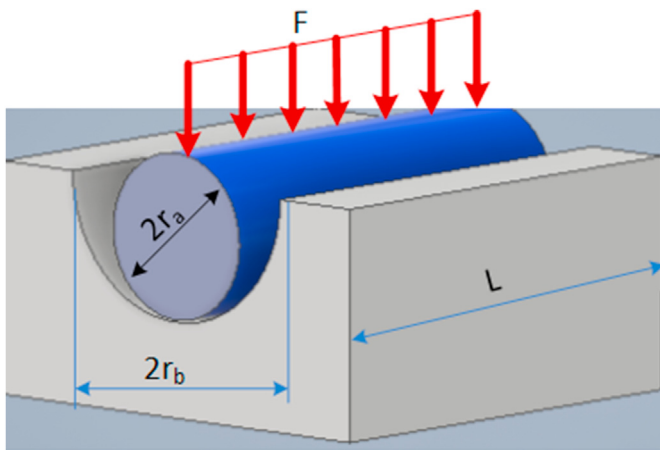

Fig. 2. An illustration of the pin in support.

the Hertz contact formula,

$$a = \sqrt{\frac{2F \left(\frac{1-\nu_a^2}{E_a} + \frac{1-\nu_b^2}{E_b} \right)}{\pi L \frac{1}{2} \left(\frac{1}{r_a} - \frac{1}{r_b} \right)}}, p_{max} = \frac{2F}{\pi a L} \text{ and } p_{av} = \frac{F}{A_{contact}} = \frac{F}{2aL}$$

where a represents half the contact width between the two contact surfaces, the support bore and the pin, and F , L , r_a and r_b represent the applied load, contact length and radius of the pin and the support hole, respectively. E and ν represent the Young's modulus and the Poisson's ratio respectively. The surfaces in contact can be cylinder in cylinder, cylinder against cylinder, cylinder on flat surface, and combinations with a ball, as analysed by Brezeanu [12], and Purushothamam and Thankachan [13].

A standard cylindrical pin would have a tolerance, or play, against the bore during installation, but with an increasing play over time, due to wear because of the repeating relative movements between the pin and the bore. The increased wear results in a decreased contact width $-2a$, which increases the contact pressure and accelerates the wear effects.

An expanding pin assembly, on the other hand, would create a 360° radial contact pressure between the contact surfaces of the pin and the support bore due to the wedge force introduced by the expanding sleeves when torquing the tightening screws, which prevent the relative movements between the pin and the supports and thereby also any wear. In addition, the external load ($F_{ex} = 2 \cdot F$) increases the radial contact pressure over 180° contact surface of the pin assembly itself. The surface contact area on the opposite side of the loaded pin side will have an increased surface contact stress level, and the surface contact area on the same side will have a reduced surface contact stress level (Fig. 3). It could be expected that the increased and decreased surface contact stress can be described by the formulas for P_{max} and P_{av} , as for a cylindrical pin in a support.

Half the contact width $-a$, max and average Hertz contact pressure, P_{max} and P_{av} , respectively are given in Table 2. The input variables that resulted in the values given in the table are: nominal pin and bore diameter Ø80 mm, bore and pin tolerances H7/h7 for the new cylindrical pin and wear value of 2 mm on diameter for the old cylindrical pin connection and zero for the expanding pin connection. Bore and pin contact length is 40 mm for the cylindrical pins and 35 mm for the expanding one. The load F is applied on each support. All pins are made of material 34CrNiMo6+QH, and the supports are made of S355J2. The pin material has a typically minimum yield strength of 800 MPa, and the support material strength is 355 MPa.

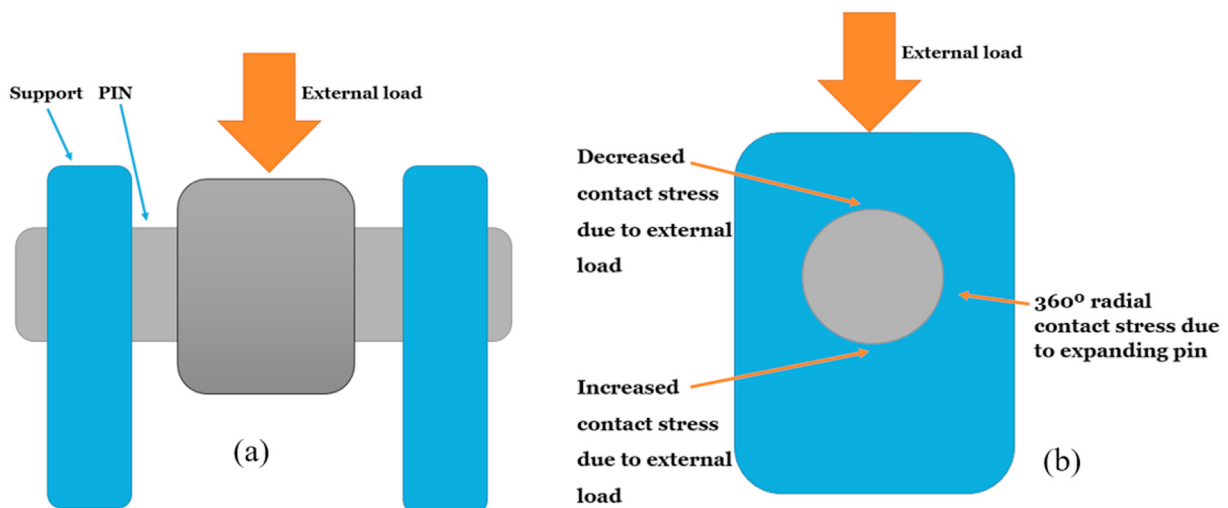

Fig. 3. Contact stresses in expanding pin solution with external load.

Table 2
 “a” value, max and average contact pressure as function of external load F on each support.

F [kN]	New cylindrical pin			Used cylindrical pin			Expanding pin – new and used		
	“a” [mm]	P _{max} [MPa]	P _{av} [MPa]	“a” [mm]	P _{max} [MPa]	P _{av} [MPa]	“a” [mm]	P _{max} [MPa]	P _{av} [MPa]
150	33	72	56	8	294	231	63	43	34
300	47	102	80	11	416	327	63	87	68
450	58	125	98	14	510	400	63	130	102
600	66	144	113	16	589	462	63	174	136
750	74	161	126	18	658	517	63	217	170
1.000	86	186	146	21	760	596	63	290	227

It can also be noted that when the cylindrical pin has worn to a play greater than 0.23 mm, its contact pressure surpasses the contact pressure of the expanding pin solution at load 1.000 kN, and greater than 0.11 mm at load 600 kN. At load 220 kN and a play of 2 mm the contact pressure for the cylindrical pin reaches the yield limit of the support steel, i.e. 355 MPa.

It can be seen from Table 2 that by increasing the external force F, the different “a” value for the new and used cylindrical pin increases, as expected, but for the expanding pin the “a” value is constant. The expanding pin solution is designed to work in all operational situations with full contact between the pin and the bore, independent of the load F, which means a maximum and constant “a” value all the time. When the “a” value is constant the P_{max} and P_{av} values are linear with the force F. If the F is doubled from 150 kN to 300 kN, the max and average contact pressure is also doubled. If the “a” value is not constant, but dependent of the F, the max and average contact pressure is increasing less than the double, due to the increased “a” value.

In addition, there could be tangential tension stress, the Hoop stress, on the bore surface and compression stress on the pin surface depending on the interference level and friction coefficients for the surfaces. An approximate indication of this stress can be found by applying an analytical approach with the Lamé’s equations (elasticity theory for thick walled cylinder), often applied when calculating deformations and stresses at interference fit connections [14,15].

An expanding pin system [2–4] (Fig. 4) combines some of the advantages from the other pin joint categories such as shrink fitted pin, the press-fitted pin and the standard cylindrical pin, while it also avoids their main disadvantages.

Shrink fitting by cooling is a way of achieving an interference fit of the pin and taking advantage of its thermal contraction before assembly, and a typically cooling medium can be liquid nitrogen at –196 °C [16]. After assembly, when the pin returns to an ambient temperature, the thermal expansion results in a strong contact pressure between the pin and its contact surfaces. Although there are many advantages with shrink fitting a pin in a moveable joint, there are certain disadvantages. It requires a system for cooling to extreme low temperatures and it might be complicated or impossible to retrieve the pin, if required, due to the complicated process involving high or low energy situations. To install

the bolt in mobile machines such as excavators, the machine will have to be transported to a distant workshop because such a process might not be possible at to perform at the machine operation site. The installation tolerance would be as wide as necessary to get the pin installed and depending on the cooling process the operation tolerance will be reduced to zero. Many investigations have been performed with the aim to learn more about the different effects involved in the process. McMillan et al. [17] studied the slip at the interface surfaces between a circular shaft and a hub exposed to axial load, where the slip was measured by drilling a small diameter hole through the assembly. The profile of the hole was then measured by a Talysurf profilometer, with an accuracy of 1–2 µm. Mouaa et al. [18] presented an analytical model analysing the stresses in an assembly with a solid shaft and hub, within the elastic-plastic range, while Toma [19] studied a new construction method “shrink fitting method by high-frequency induction heating”. Gutkin and Alfredsson [14] investigated the growth of fretting fatigue cracks in a shrink-fitted joint subjected to rotating bending.

Press-fitting a pin into a joint is another method of achieving an interference fit without applying high temperature or cooling of any of the involved parts. A commonly used method would be to use a pin with a diameter slightly greater than the joint bore and load the pin axially to force it into correct position. The interference fit level in a press-fitted joint can be defined as [20].

$$I = \frac{D - d}{d} \times 100\%$$

where D is the pin diameter, and d is the bore diameter.

As for the shrink fitting by cooling, the press fitting technique creates a solid and firm interference fit but could as well be very complicated both to insert and retrieve if required. The installation tolerance would be negative but forced to zero which then would be the operation tolerance. As for shrink fit connection by cooling, a press fit joint could be complicated or impossible to disarm and retrieve outside a well-equipped workshop, often distant from the actual operation area of the machine. Murcinková et al. [21] studied dimensional parameters of the press fit bearing-shaft joint, by analytical and numerical approach, and Strozzi et al. [22] investigated the stress concentrations at the rounded edges of the hub in an interference fit with a solid shaft, subjected to bending. Lee

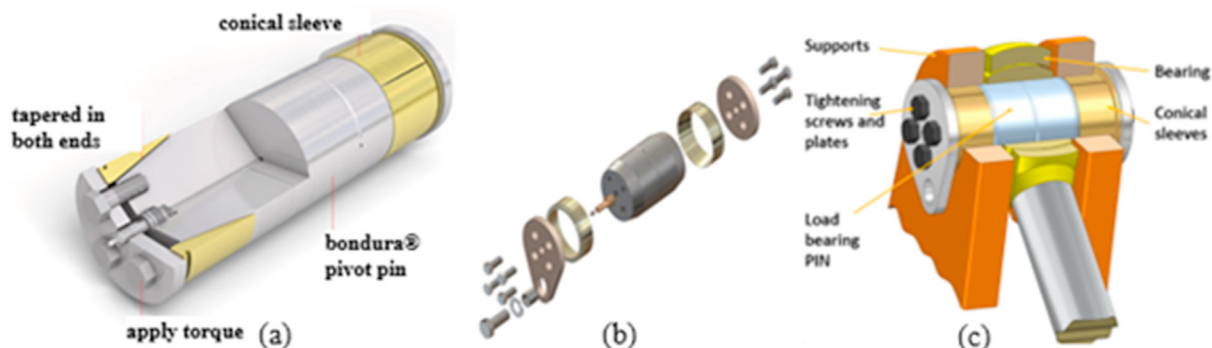

Fig. 4. Expanding pins - (a) pin assembly, (b) exploded view, (c) pin installed in joint.



Fig. 5. Std cylindrical pins - (a) and (b) play due to tear and wear of supports, (c) cold welded pin.

at al [23]. studied fatigue damage in a press-fitted shaft under bending. An experimental attempt was made to understand better the fretting damages in press-fitted connections using a rotating bending fatigue machine under constant amplitude cyclic loading. Song et al. [24] also investigated rotary bending fretting fatigue damage, of railway axles.

A standard cylindrical pin will normally have a slightly smaller diameter than the hole where to enter. This tolerance can vary depending on the pin size, weight, length, complexity of the installation process etc. Typical tolerances on the pin and bore are defined in ISO-2768, which is a geometrical tolerance standard with the intention to simplify drawing specifications for mechanical tolerances [25]. Although the standard cylindrical pin often is an easy solution when it comes to the installation process it might result in damaging wear on the supports during operation or cold welding between pin and support, as shown in Fig. 5.

2.2. Applications of expanding pin systems

The expanding pin system [2,4] can operate with any required installation tolerance, like the standard cylindrical pin. The end-sleeve at an expanding pin works as a wedge between the tapered end of the pin and the support bore wall and prevent any relative movement between the surfaces in contact; pin/sleeve and sleeve/bore wall. The wedge force is produced when torquing the tightening screws or nut, which again pushes the end-sleeve in between the tapered end of the pin and the bore wall. This function allows the expanding pin to operate with an interference fit towards the support bore, much like the shrink-fit pin and the press-fit do. It is easy and straight forward to retrieve an installed expanding pin system. The tightened screws or nuts must be loosened, the sleeve is removed by special tool if required, and the pin can be retrieved easily. The retrieval process of an expanding pin system is therefore different compared to the same process for a shrink fit pin by cooling or a press fit pin.

The development of more sophisticated expanding pin solutions started in the late 80's and early 90's as solutions to smaller excavators and other agricultural equipment suffering major tear and wear problems in the moveable joints. Later, these solutions were introduced into the Oil&Gas and maritime industry, in addition to high volume OEM vehicles for agriculture, forestry, mining etc. The expanding pin technology is still in little use compared to the use of standard cylindrical pins, and it is not as well-known as shrink fit and press fit are. However, the knowledge about this solution is increasing and it can be found in various industries in various countries.

The expanding pins come in various forms, sizes, and material qualities, depending on.

- the type of industry, equipment, and joints where to be installed,
- the exposure to corrosive environments, loads and vibrations,
- issues and problems to be solved,
- patents and other intellectual property (IP) restrictions, stakeholders' preferences and much more.

The expanding pin solution resolves various issues and problems which other pin solutions cannot resolve easily. In addition to the previous mentioned tear, wear and ovality problems that often occur (Fig. 5), the expanding pin can:

- Easily be installed and retrieved in situations with heavy pins with requirements to minimum installation tolerances in combination with complicated joint positions.
- Prevent situations where the cylindrical pin could get cold-welded or contact-welded to the bore, and difficult or impossible to disassemble unless destructive methods such as flame cutting, welding and line boring are used. The cold-welding is a solid-state welding process without heating, where similar metals strongly adhere when the atoms in contact "recognize" each other. The cold-welding could overlap with galling, fretting, sticking, and adhesion.
- Provide a higher grade of safety for personnel and equipment during installation and retrieval of the pin
- Reduce the risk of breakage of the pin because of reduced reactions forces, or accelerations, due to prevention of relative movements between the pin itself and the supports it is connected to, ref Fig. 6, compared to a standard cylindrical pin solution.
- Reduce both the planned and unplanned down-time due to better control and less unwanted issues.

Expanding pin solutions are applied in a wide range of machines within many industries and geographical areas, but still not equally known in the different markets and segments as the standard cylindrical pins. Expanding pins are normally applied in positions and joints where there are known to be some specific issues in the past or expected to be in the future, or where it is needed to ease the process of installation and retrieval (Fig. 7). Such issues involve typically heavy loads, vibrations, accelerations, punches/hammering, tear and wear, ovality, breakage of pins, requirements of a minimized operational tolerance between pin and supports, long installation and retrieval time of pins, damage of bearings, unwanted mechanical noise, corrosion, etc., and such expanding pin solutions can often be found in:

- Offshore, onshore and mining drilling and pipe handling equipment
- Offshore, maritime and port handling cranes, in addition to tower cranes
- Earth moving equipment and vehicles, both onshore, mining and for dredging
- Steel and cellulose fabrication machines
- Many more

3. Research methodology

To investigate the stakeholder's experiences and opinions regarding the use of expanding pin technology, a questionnaire was developed and sent to 323 contacts. The selected contacts (companies) for the questionnaire are those assumed to have a certain knowledge of the

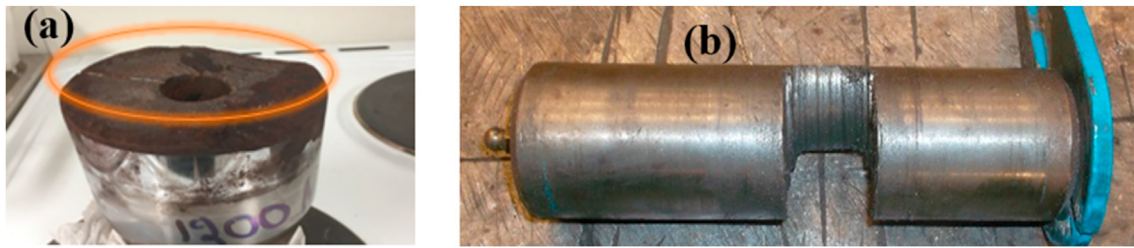

Fig. 6. Std cylindrical pins - (a) breakage of pin, (b) wear damaged pin.

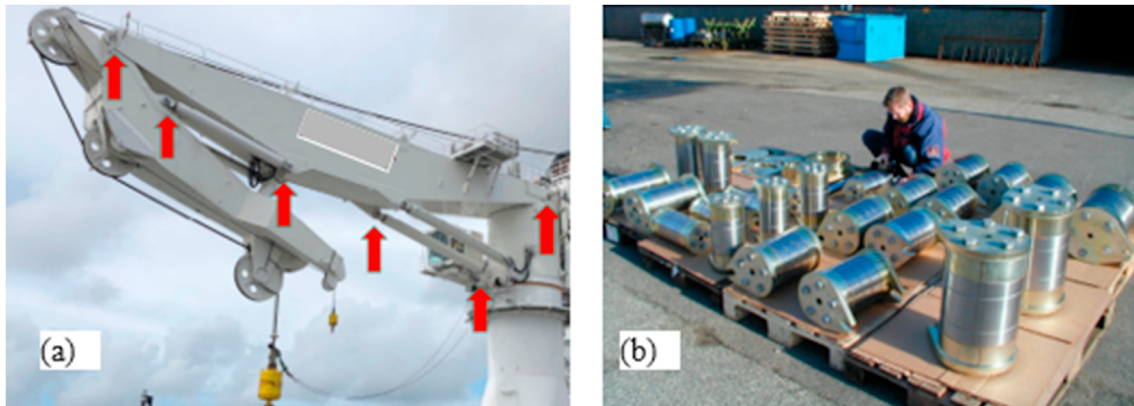

Fig. 7. Expanding pins (a) installed in a maritime crane, (b) pins prepared for offshore cranes.

expanding pin technology. Among these, 22 failed delivery messages, and 45 stated immediately to have no knowledge of the technology. Of the remaining companies, 23% responded positively by filling in the questionnaire or giving comments apart.

The questionnaire was distributed to potential respondents by e-mail with the questionnaire attached as an editable pdf file. 41% answered by typing directly into the pdf file, 52% answered by manually filling in a printing out copy and 7% did not answer the Questionnaire directly but gave written comments in e-mail reply. The original Questionnaire version was made in English, but some respondents asked for a Norwegian version, which was delivered.

The Questionnaire contained diverse questions organized under six sections as listed below.

- (1) Size of the company
- (2) Company profile
- (3) How long the company applied, specified, or worked with expanding pin technology
- (4) On which type of market and equipment the company applied the technology
- (5) Whether the company is using own designed expanding pin or from others
- (6) Effects and consequences of applying expanding pin solutions

These questions are designed to collect required data from the personnel, companies or respondents that are intended to fall under three main categories: (i) characteristics and profile of the companies – sections (1) and (2), see Chapter 4.2; (ii) type and period of usage of expanding pin technology by the companies – sections (3)–(5), see Chapter 4.3 and (iii) effects and consequences of using expanding pin technology experienced by the companies – section (6), see Chapter 4.4. While the questions under category (i) are intended to provide some background information, questions under category (ii) and (iii), particularly questions under section (4) and (6) represent the main sections of the investigation about market/equipment and the effects and consequences of applying expanding pins respectively. In section (4), each

segment a) to i) contains options of questions regarding type of equipment and machines used by the industry, and in section (6) each segment a) to o) contains choices for effects and consequences.

4. Analysis and discussion of results

4.1. Distribution and feedback rate of the questionnaire

The survey was distributed to 323 contacts in various companies, where 22 were returned as error messages and 45 reported to have no experience or knowledge to the products and therefore declined to participate. This leaves 256 potential respondents and among these 140 (55%) are Norwegians and 116 (45%) are from other countries. In this survey a company is defined as Norwegian when the responses are coming from its Norwegian location, and not because of ownership or global main office location. The overall response rate for the survey is defined as the number of responses compared to the number of mailings, and for this survey it is 23%, or 58 responses out of 256 potential responders, who received the questionnaire as an editable pdf file, added to an e-mail.

Comparing the distribution of the feed-back from the survey with the distribution of all the receivers of the survey (Fig. 8), it can be observed that it is a relatively higher response rate from the Norwegian companies compared to the remaining companies. The Norwegian companies represent 55% of the total potential responders, and 67% of the total received responses, which gives an overall relative reaction rate of 1.23 (i.e. total number of received Norwegian responses [%] divided by the total number of potential Norwegian responders [%]). For the non-Norwegian respondents, the value is 0.72. The overall relative reaction rate of the Norwegian companies is then 70% higher than for the others.

The reaction rates are calculated as indicated in Table 3. The overall reaction rates indicate the relationship between each group's (Norwegian or non-Norwegian companies) response willingness in %-age, and the same groups share of the requests (mailings) for participating in the Survey (total rate for potential responders). The segment relative reaction rates are calculated by the response willingness per segment,

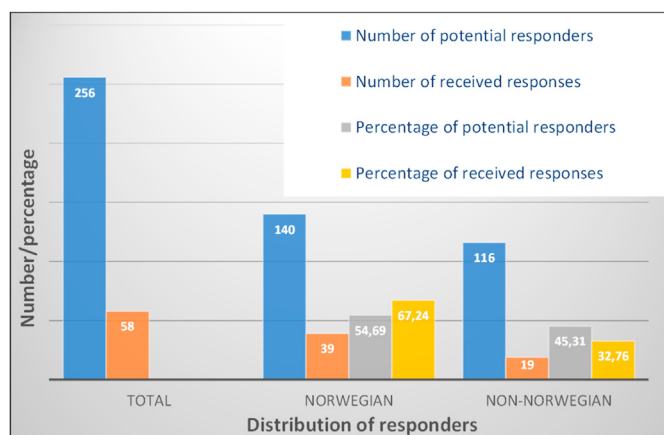

Fig. 8. Overall distribution of responders.

compared to the same total rate for potential responders, as for the overall reaction rates, as indicated in Table 4.

4.2. Location and profile of responding companies

As shown in Table 5, the total number of respondents in this Survey is 58, where 39 (67%) come from Norway and the remaining 19 (33%) come from 9 other countries in three different continents, with a total distribution of Europe 55 (95%), North America 2 (3%) - and South America 1 (2%). The second and third dominant responders are Scotland with 6 (10%) and Sweden with 5 (9%). Percentages are with respect to the total responders.

The responses received on the Questionnaire would be a combination of the perception of the responding person and the actual company's experience. Though only single responses were received from most companies, a few bigger companies have responded with more than one Questionnaire, in which case the answers and comments are coming mainly from different areas within the company that are often working with different types of equipment and therefore having different experiences. Responses from different persons with different experiences on the same product area or department within the same company are therefore expected to increase the Survey's accuracy on the company's experience.

The size distribution and profile of respondents are given in Table 6.

Table 3
Overall reaction rate structure.

	Received responses			Relative reaction rates	
	Total, No. (%)	Norwegian No. (%)	Non-Norwegian No. (%)	Norwegian (-)	Non-Norwegian (-)
Total received responses	58 (100)	39 (67)	19 (33)	1.23*	0.72
Total potential responders	256 (100)	140 (55)	116 (45)		

* Calculation of exact overall reaction rates; Norwegian: $67.24\%/54.69\% = 1.23$ and Non-Norwegian: $32.76\%/45.31\% = 0.72$.

Table 4
Segment wise overview of received responses and calculated relative reaction rates.

Segment	Received responses			Relative reaction rates	
	Total, No.	Norwegian, No. (%)	Non-Norwegian, No. (%)	Norwegian (-)	Non-Norwegian (-)
a) Offshore Oil&Gas	30	20 (67)	10 (33)	1.22	0.74
b) Marine – ships	19	16 (84)	3(16)	1.54	0.35
c) Subsea – ROV/str.	5	5 (100)	0 (0)	1.83	0.00
d) Dredging	7	7 (100)	0 (0)	1.83	0.00
e) Mining	12	9 (75)	3 (25)	1.37	0.55
f) Construction and earth moving – onshore	17	16 (94)	1 (6)	1.72	0.13
g) Specialized machines	5	5 (100)	0 (0)	1.83	0.00
h) Steel and paper ind.	5	1 (20)	4 (80)	0.37	1.77
i) Other	6	3 (50)	3 (50)	0.91	1.10

Table 5
Location of responder companies.

Responders' locations	Distribution of locations	
	No of respondents	%
Total	58	100
Europe	55	95
Norway	39	67
Scotland	6	10
Sweden	5	9
Finland	2	3
The Netherlands	1	2
Greece	1	2
Germany	1	2
North America	2	3
Canada	1	2
USA	1	2
South America	1	2
Brazil	1	2

The company size distribution is defined by the size of employees as less than or equal to 20, 21–100 and over 100. The company profile is defined as OEM, Supplier to OEM, Engineering company, End-user, Service & Maintenance, and others.

Excluding companies in Norway, almost 2/3 (63%) of the respondents indicate that their company size is represented by more than 100 employees, while the remaining are distributed between company size with 21–100 employees (26%) and less than or equal to 20 employees (11%), respectively. Both the Scottish and Swedish companies have a relatively high percentage of the bigger companies, i.e. over 100 employees; 5 (83%) and 3 (60%), respectively, compared to Norway with 18 (46%).

The companies' profile, or type of business area (Table 6) also show that 92% of the respondents from the 6 possible areas are distributed over 4 areas, namely OEM, Engineering, End-user and Service & Maintenance companies with 19 (20%), 21 (22%), 18 (19%) and 30 (31%), respectively, with Service & Maintenance being the biggest.

4.3. Type and period of usage of expanding pin technology by the companies

Some of the companies work in one segment only, while others have parallel activities in various segments. The combinations between respondents and the activities in the various segments, as obtained from the Survey results are given in Table 7. The three main segments are "Offshore Oil&Gas", "Maritime/ships" and "Construction/earth moving"

Table 6
Company size and profile.

		Norway		Scotland		Sweden		Total excl. Norway		Total Survey	
		No	%	No	%	No	%	No	%	No	%
Total		39	100	6	100	5	100	19	100	58	100
Company size	CS1	12	31	0	0	0	0	2	11	14	24
	CS2	9	23	1	17	2	40	5	26	14	24
	CS3	18	46	5	83	3	60	12	63	30	52
Total		63	100	12	100	5	100	33	100	96	100
Company profile	CP1	13	21	4	33	1	20	6	18	19	20
	CP2	3	5	0	0	0	0	2	6	5	5
	CP3	13	21	3	25	0	0	8	24	21	22
	CP4	12	19	3	25	1	20	6	18	18	19
	CP5	22	35	2	17	2	40	8	24	30	31
	CP6	0	0	0	0	1	20	3	9	3	3

CS1: No. employees ≤20; CS2: No. employees = 21–100; CS3: No. employees >100.

CP1 = OEM; CP2 = Supplier to OEM; CP3 = Engineering companies; CP4 = End user; CP5 = Service & maintenance; CP6 = Others.

Table 7
Distribution of responses on segments.

Segments (9 different):	Distribution of the 139 responses from 58 respondents, on 9 different segments			
	No. of respondents per segment	% - of total respondents (58)	No. of responses on equipment, per segment	% - of total responses (139)
Total	106		139	
a) Offshore oil&gas	30	52	42	30
b) Maritime/ships	19	33	32	23
c) Subsea – ROV/str.	5	9	6	4
d) Dredging	7	12	11	8
e) Mining	12	21	14	10
f) Constr./earth moving	17	30	18	13
g) Specialized mach.	5	9	5	4
h) Steel and paper	5	9	5	4
i) Other	6	10	6	4

with 30 (52%), 19 (33%) and 17 (30%) respondents involved, respectively, of 58 in total. In total, responses from 9 different segments were collected where 58 respondents have given 139 responses and confirming activity with expanding pins in a total of 106 times in various and

repeating segments, which indicates that each respondent has activity in an average of 1.83 segments, and is involved in an average of 2.4 different types of equipment within the selected 9 segments.

Within the “Offshore Oil&Gas” segment, which is the biggest segment, the equipment that mostly apply expanding pins are the “Drilling and pipe handling equipment” and “Offshore cranes” (Fig. 9 (a)), with 40% and 50%, respectively, of the total responses. The Norwegian based companies represent here 62% of all the segment a) responses, and specifically for the “Offshore cranes” 67%. The segment relative reaction rates for the Norwegian companies and the non-Norwegian for the segment a) are then 1.22 and 0.74, respectively, see Table 4.

For the second biggest, segment “Maritime-ships” (Fig. 9(b)), “Maritime cranes” and “A-frames” are the main equipment types for these pins, with 44% and 25% of the total responses, respectively. The segment b) relative reaction rates for this segment for the Norwegian companies and the others are 1.54 and 0.35, respectively, see Table 4. The Norwegian based companies represent here 88% of all the responses, and for “Maritime cranes” 93%, and with high participation also in the other types of equipment.

In the case of the third biggest segments, i.e. “Construction and earth moving – onshore”, expanding pins technology is mostly applied in “Vehicles” category with 56% proportion relative to the total in the segment. For this category, over 9 of 10 responses are from the Norwegian companies. The segment f) relative reaction rates for this segment for the Norwegian companies and the non-Norwegians are 1.72 and 0.13, respectively (Table 4). The different responders have different length of experience with expanding pin solutions, where the experience of Norwegian companies dominate the statistics followed by Scottish and

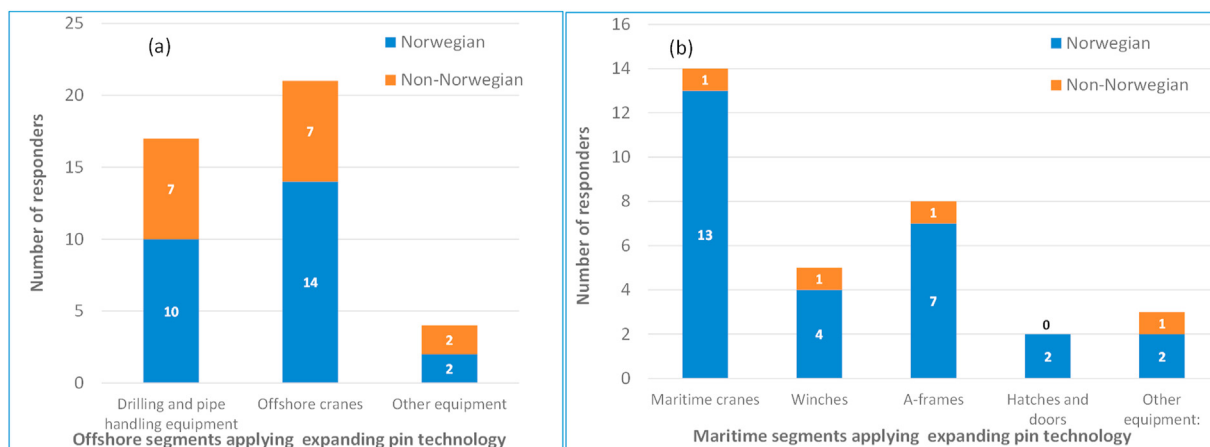

Fig. 9. Overview of respondents that apply expanding pins in (a) Offshore and (b) Maritime segments.

Table 8
Experience with expanding pin solutions.

		Norway	Scotland	Sweden	Total excl. Norway	Total Survey
		No (%)	No (%)	No (%)	No (%)	No (%)
Total		39 (100)	6 (100)	5 (100)	19 (100)	58 (100)
[years]	<1	1 (3)	0 (0)	0 (0)	0 (0)	1 (2)
	1–10	14 (36)	2 (33)	3 (60)	9 (47)	23 (40)
	>10	23 (59)	4 (67)	2 (40)	10 (53)	33 (57)
	Others	1 (3)	0 (0)	0 (0)	0 (0)	1 (2)

Swedish companies (Table 8). The survey shows also that a majority of the Norwegian companies have more than 10 years of experience in using the expanding pin solutions.

The remaining segments have lower numbers of responses, from 5 to 12 each, see Table 7. For three of these segments, namely “Subsea (ROV and structure)”, “Dredging (sea, lakes, and rivers)” and “Specialized machines and equipment” segments, only Norwegian responders were received with applications in cranes and A-frames as important equipment. The segment that is reported to have least application includes industries and equipment not included in the previous segments, NASA launch vehicles, special equipment for the metal industry, etc.

The relative reaction rates for the “Offshore Oil&Gas” segment, 1.22 and 0.74, indicate that there is a difference in the response willingness between the Norwegian based companies and the others, with 66% higher for the Norwegian companies. This could be explained by the fact that the national Norwegian and foreign Oil & Gas industry have known and applied the expanding pin technology for years. A slightly higher score from the Norwegian companies is logical since this doctoral research is being performed and supported by the company which introduced the technology into the national Norwegian oil and gas offshore market. The corresponding rates for the Maritime/ships segment, 1.54 and 0.35, are much more distant in values, with a corresponding willingness of 342% higher for the Norwegian companies. The Bondura company has delivered expanding pin systems to various bigger OEMs within the Norwegian maritime sector for the last 20–25 years, but only in minor scale to any foreign company within the same sector. This could possibly explain the huge difference in the segment relative reaction rates, for this specific segment.

The source of expanding pins for all companies is given in Table 9. Most of the respondents use an external source for expanding pins, 54 of 62, or 87%. The remaining 8 (13%) are in one way or another using their own designs for some or all of their equipment. For the Norwegian respondents 6 out of 42 (14%) claim that they apply their own designs, rather than solutions from external sources, and for the other companies the numbers are 2 out of 20 (10%). 75% of the companies applying their own expanding pin design are coming from Norway, compared to 25% from the other countries. Of all the 8 companies applying their own expanding pin design 6 (75%) belong to the bigger size, having over 100 employees, and 6 (75%) of them have worked with expanding pins for

Table 9
Expanding pin source.

Alternatives	Are the expanding pins you are using your own design, or from others?								
	Total survey			Survey excl. Norway			Survey Norway		
	No.	%-tot.		No.	%-tot.	%-alt.	No.	%-tot.	%-alt.
Total	62	100		20	100	32	42	100	68
Company’s own design for own products	8	13		2	10	25	6	14	75
From external supplier	54	87		18	90	33	36	86	67

over 10 years, 4 (50%) of the companies belonging to both groups; being big with long experience. The 8 companies work mainly in “Offshore”, “Maritime” and “Construction & Earth moving” segments, with 3, 4 and 4 companies involved, respectively.

4.4. Effects and consequences of applying expanding pin technology

The main objective of this survey is to investigate the effects and consequences of applying expanding pin solutions based on survey questionnaire divided into 20 questions with various response alternatives. The response rates for the Norwegian-based companies vs the other companies for all the questions in this section (6) are also evaluated, which resulted in an average rate of 65% and 35% respectively, out of 851 responses in total. The section relative reaction rates for this section are the same as for the over-all reaction rates for the survey, with of 1.23 for the Norwegian and 0.72 for the non-Norwegian companies.

As can be observed from Table 10, the main reason why the responders are choosing expanding pin systems is based on previous experiences (Q2) and that the pins come with the equipment (Q4) with 51% and 22% proportion of the total survey, respectively. The non-Norwegian companies have the strongest relationship between previous experience and the reason for choice of pins, with 58%. The Service & Maintenance company profile is the one where most responders are confirming the previous experience as the main reason for continue choosing expanding pins, with 20 of the 32, and 8 of those companies with more than 100 employees and 10 having more than 10 years of experience with expanding pins, independent of geographical location. Some responders (13%) state that pressure from their own clients have been the reason for choosing the expanding pins solution.

Where Q1 – It is a strong wish or requirement from our clients; Q2 – It is based on our own previous experience, Q3 – It is new for us and we want to test it, Q4 – The pins come with the equipment when we receive it and “Other reasons” - [(1) When it is urgent, but line boring is preferred if possible (2) When play is a problem and the alternative is line boring, (3) Aftermarket and repair jobs].

The importance of installation and retrieval time is valued differently between the two groups of companies, Norwegian and non-Norwegian. Around 67% of the Norwegian responders are of the opinion that installation and retrieval time is Important or Crucial and decisive, but for the non-Norwegian companies the number is close to 90%. The actual experiences of installation and retrieval time with expanding pins compared to standard pins are shown in Fig. 10. From the 11 responders claiming to have longer installation time with expanding pins, 6 belong to both “>100 employees” and “>10 years of experience with expanding pins”, and for retrieval time the corresponding numbers are 12 and 5 responders.

In total 44% confirm that Installation time is reduced by use of expanding pins, and for Retrieval time the number is 58%, with a slightly higher score for the non-Norwegian companies on Retrieval time, with 65%.

Table 10
Why choose expanding pins.

Alternatives	What is the reason for your company to choose or work with expanding pin technology?								
	Total survey			Survey excl. Norway			Survey Norway		
	No.	%-tot.		No.	%-tot.	%-alt.	No.	%-tot.	%-alt.
Total:	63	100		19	100	30	44	100	70
Q1	8	13		1	5	13	7	16	88
Q2	32	51		11	58	34	21	48	66
Q3	6	10		2	11	33	4	9	67
Q4	14	22		5	26	36	9	20	64
Other reasons:	3	5		0	0	0	3	7	100

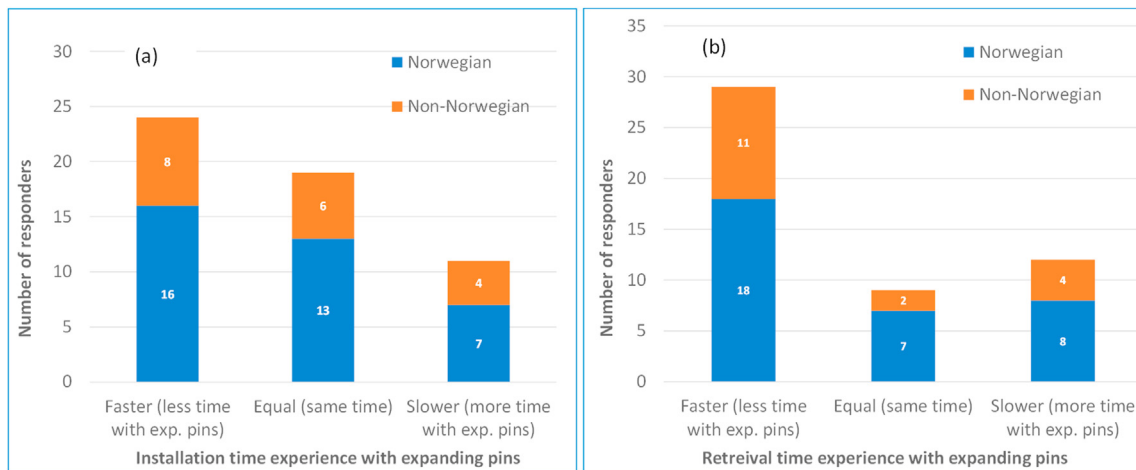

Fig. 10. Number of responders on (a) Installation time, and (b) Retrieval time.

The importance of avoiding breakage damage is highly valued by all respondents in the survey, except one, with 45% indicating that it is of “Crucial and decisive” importance. The actual experiences of tear, wear and breakage damages with expanding pins compared to standard pins are shown in Fig. 11. The study clearly shows an experienced improvement both for tear & wear and breakage problems when using expanding pin instead of standard cylindrical ones. 68% of the non-Norwegian companies claim less tear and wear issues with expanding pins, and for the Norwegian companies 59% claim the same. For breakage issues the comparative figures are 71% and 38%, showing a clearly better experience for the non-Norwegian companies. From the 12 non-Norwegian companies with experience of less breakage issues with expanding pins, 7 (58%) have more than 10 years of experience, and 6 (50%) work within the Offshore Oil&Gas industry.

Expanding pins with locking capability to bearing in addition to the supports are called Dual pins. The survey shows that only a minority of the respondents, 14%, have used that specific design, mainly because many have no need for it, or no knowledge of the design. Those who had some experience with Dual pins reported “More efficient machine or equipment” and “Longer lifetime of bearing” as the advantages.

The importance of applying safe pin solutions is highly valued by most respondents, except from two. The non-Norwegian companies have a higher score on “Crucial and decisive” than the Norwegian, with 47% vs 31%, respectively (Fig. 12 (a)). Half of the respondents believe the expanding pin solution is as safe as a standard pin, for personnel and

equipment, and 47% experience a higher level of safety (Fig. 12 (b)). The non-Norwegian companies value the expanding pin solutions as much safer than the standard solution, compared to the Norwegian, with 60% and 39%, respectively.

Those who have experienced the expanding pin solutions as safer than a standard solution have indicated their reasons as shown in Table 11. From a safety point of view for the total survey, it is highly valued that the expanding pin solution does not need sledgehammering to enter the joint (43%), together with the easiness to be retrieved when required (28%). However, there are considerable variations between the Norwegian and non-Norwegian companies, with 33% and 63% for sledgehammering and 33% and 19% for easiness of retrieval, respectively. Where Q1 - No need for sledgehammering to get the expanding pin into the joint; Q2 - No relative movements between expanding pin and supports during service/operation; Q3 - Less chance for breakage of pin during service/operation and Q4 - Easy and fast to retrieve when required.

As can be observed from Table 12, the responders confirm that they observe a number of advantages by using expanding pins compared to standard cylindrical pins, and without major differences between the Norwegian and non-Norwegian based companies. The most important advantages with expanding pins are “Less, or no wear”, “Reduced unwanted downtime”, “Longer lifetime on equipment”, and “Reduced planned downtime”, with 24%, 23%, 23% and 20%, respectively.

Where Q1 - Reduced unwanted downtime on production with expanding pins; Q2 - Reduced number and length of planned downtime

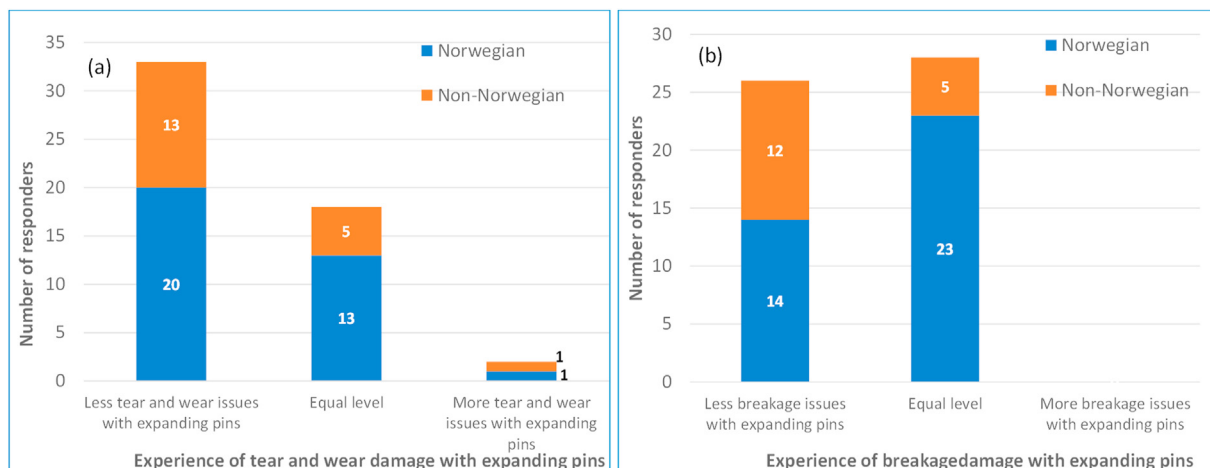

Fig. 11. Number of responders on (a) tear and wear damage, and (b) breaking damage.

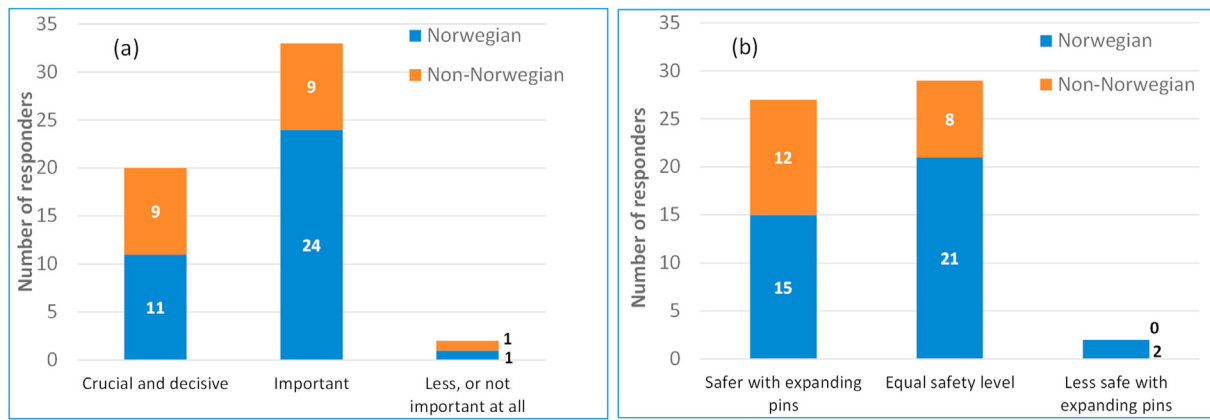

Fig. 12. (a) Importance of safe pin solution, and (b) Safety for personnel and equipment.

Table 11 Comparison of safety of expanding pins with standard pins.

Alternatives	If you marked expanding pins as safer than standard cylindrical pins in the previous question, why?							
	Total survey		Survey excl. Norway			Survey Norway		
	No.	%-tot.	No.	%-tot.	%-alt.	No.	%-tot.	%-alt.
Total	46	100	16	100	35	30	100	65
Q1	20	43	10	63	50	10	33	50
Q2	5	11	2	13	40	3	10	60
Q3	6	13	0	0	0	6	20	100
Q4	13	28	3	19	23	10	33	77
Other reasons	2	4	1	6	50	1	3	50

Table 12 Other effects and consequences.

Alternatives	Which other effects and consequences do you see for the equipment and machines in relation with repair, service, and operation, when using expanding pin solutions instead of standard cylindrical pins?							
	Total survey		Survey excl. Norway			Survey Norway		
	No.	%-tot.	No.	%-tot.	%-alt.	No.	%-tot.	%-alt.
Total	114	100	49	100	43	65	100	57
Q1	26	23	10	20	38	16	25	62
Q2	23	20	11	22	48	12	18	52
Q3	27	24	12	24	44	15	23	56
Q4	6	5	3	6	50	3	5	50
Q5	26	23	11	22	42	15	23	58
Q6	6	5	2	4	33	4	6	67

for service; Q3 - Less or no wear damage on expanding pins and supports; Q4 - Reduced corrosion on expanding pins; Q5 - Longer lifetime of equipment and machines, with expanding pins and Q6 - We don't see any specific advantages with expanding pins.

Fig. 13 shows the economic impact that the use of expanding pins may have on the responders' companies, instead of applying standard cylindrical pin solutions. The responses show that 85% of responders confirm the importance to be "Crucial and decisive" or "Important". The non-Norwegians have a clearly higher score on "Crucial and decisive" than the Norwegians with 39% vs 12%, but for "Important" it is the opposite with 39% vs 76%, respectively. At the same time, it can be noted that a relatively higher number of non-Norwegian based companies value the expanding pin solution as "Less, or not important at all", compared to the Norwegians, with 22% and 12%, respectively.

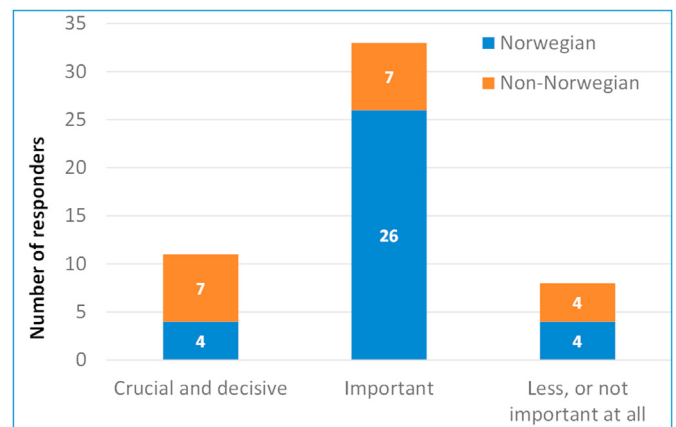

Fig. 13. Economic impact of expanding pins compared to standard pins.

5. Conclusion

In this questionnaire-based study, a total of 256 potential respondents received the questionnaire, divided into 140 Norwegian based companies, and 116 non-Norwegian. In total 58 responded, divided into 39 Norwegian based companies, and 19 non-Norwegian, with an over-all response rate of 23%, and the Norwegian based companies had a considerable higher willingness to respond, compared to the non-Norwegian based. Though not easy to conclude, it is assumed that the long and strong relationship between Bondura and the Norwegian Offshore Oil&Gas industry and Maritime sector might have influence on the willingness to respond, in addition to the participation of The University of Stavanger and The Norwegian Research Council.

Most of the respondents apply an external source for expanding pins, but 8 of the 62 responses from the 58 respondents confirm using their own design, where half of them belong to companies with more than 100 employees and having more than 10 years of experience with expanding pins. This leads us to conclude that bigger companies with long experience with the expanding pin technology have got the economic interest and self-confidence to go for their own designs, exposed to possible situations with infringements to the pin supplier companies' IP rights.

For over half of the responders, the main reason to apply expanding pin technology is because of previous experience. This can be understood that the previous experiences have been good experiences, and it can also be seen that the non-Norwegian based companies put higher value to the experience with expanding pin systems than the Norwegians. At the same time, the number of Norwegian companies who choose expanding pins is due to requirements from their own customers is three times higher, compared to the non-Norwegians. This difference can partly explain by

the market activities taken by companies like Bondura during years, to make the Norwegian OEMs' customers push the OEMs to include expanding pin technology into their products.

The responders indicate that the time required for installation and retrieval of pins, in general, is of high importance for their business and activities. Almost 90% of the non-Norwegian companies define this consumed time as "Important" or "Crucial and decisive", but only 2/3 of the Norwegian companies do the same. The majority, or 2/3, of the Norwegian companies consider the installation and retrieval time to be of less or no importance belongs to the Service & Maintenance profile, with the same share for companies having more than 10 years of experience with expanding pins, and 1/3 belonging to both groups. It is not clear why some respondents mean that the installation and retrieval time is not important, but normally the well-established Service & Maintenance companies make more business when the jobs last longer.

A majority of the responders experience that the retrieval time for expanding pins is shorter than for standard cylindrical pins, with a higher score for the non-Norwegian companies, where the majority of those have more than 100 employees and more than 10 years of experience with expanding pins. Both Norwegian and non-Norwegian companies state that there are less tear, wear and breakage issues with expanding pins and supports, compared to standard pins, where the non-Norwegian companies have the most positive experiences.

Almost all the respondents agree on the importance of having a pin solution that is safe for personnel and equipment. On the other hand, about half of the non-Norwegian companies and less than a third of Norwegian companies define it as "Crucial and decisive", only. The main reason that the expanding pin solution is safer than the standard pins is because it does not need sledgehammering to get the expanding pin into the joint. Around 90% of the Norwegian and the non-Norwegian companies agree that the use of expanding pin solutions instead of standard cylindrical pins, will reduce downtime (unwanted and planned), reduced wear damage and increase lifetime of equipment and machines. Furthermore, almost all the responders agree about the importance of the economic effects of using expanding pin systems, while only around 15% see no specific importance. The non-Norwegian companies have over three times higher score than the Norwegian ones on stating the economic effects as "Crucial and decisive".

Summarizing all, it becomes clear that a majority of the respondents have a positive experience with, or an excellent perception of expanding pin systems, when it comes to installation, operation, retrieval, safety for personnel and equipment, and economic advantages for their company and clients. There could be some sources for errors or uncertainties in this survey;

- Point of time of recollecting information regarding the global covid-19 situation.
- For the segment relative reaction rates, the segment responses are applied, and the total potential responders, not the segment potential responders.

Credit author statement

Ø. Karlsen: Conceptualization, Methodology, Investigation, Writing—original draft; H.G. Lemu: Supervision, Visualization, Resources, Writing – Reviewing and Editing, Project administration, Validation. All authors have read and agreed on the final version of the manuscript.

Funding

This research is conducted under the Industrial PhD funding provided by the Research Council of Norway and the company Bondura Technologies AS, Grant nr. 283821.

Declaration of competing interest

The authors declare that they have no known competing financial interests or personal relationships that could have appeared to influence the work reported in this paper.

Acknowledgements

The authors gratefully acknowledge the financial support provided by the Research Council of Norway and Bondura Technologies AS. The authors would like to thank the companies and individuals who provided feedback on the conducted survey.

References

- [1] Ø. Karlsen, H.G. Lemu, Fretting fatigue and wear of mechanical joints, *Literature study*, IOP Conf. Ser. Mater. Sci. Eng. 700 (2019).
- [2] Bondura, «Bondura technology,» Bondura technology, [online]. Available: [Last accessed: 23 March 2020, <https://www.bondura.no>.
- [3] I. Berkani, Ø. Karlsen, H.G. Lemu, Experimental and numerical study of Bondura® 6.6 PIN joints, IOP Conf. Ser. Mater. Sci. Eng. 276 (2017).
- [4] Nord-lock, «Nord-Lock,» [online]. Available: [Last accessed: 13 July 2020, www.nord-lock.com.
- [5] S. Ahmed, X.-C. Gu, Accident-based FMECA study of marine boiler for risk prioritization using fuzzy expert system, *Results Eng* 6 (2020) 100123.
- [6] A.R. Prabowo, D.M. Bae, Environmental risk of maritime territory subjected to accidental phenomena: correlation of oil spill and ship grounding in the Exxon Valdez's case, *Results Eng* 4 (2019) 100035.
- [7] C.V. Haute, T. Pire, Maintenance intervals for MP-TP bolted connections – a case study, *Results Eng* 5 (2020) 100064.
- [8] S.A. Akintola, M. Oki, A.A. Aleem, A.A. Adedran, O.B. Akpor, O.M. Oluba, B.T. Ogunsemi, P.P. Ikubanni, Valorized chicken feather as corrosion inhibitor for mild steel in drilling mud, *Results Eng* 4 (2019) 100026.
- [9] Eurocode, «eurocode,» [online]. Available: [Last accessed: 03 August 2020, <https://eurocodeapplied.com/design/en1993/steel-design-properties>.
- [10] ArcelorMittal, «ArcelorMittal,» [online]. Available at: [Last accessed: 03 August 2020, <https://constructalia.arcelormittal.com/en/steel-grades/s420>.
- [11] Astrup, «astrup,» [online]. Available; Last accessed: 03 August 2020, <https://astrup.no/Materialer-Produkter/Materialer/Specialstaal/Rundstaal>.
- [12] L.C. Brezeanu, Contact stresses: analysis by finite element method (FEM), *INTER-ENG* 2013, *Procedia Technol* 12 (2014) 401–410.
- [13] P. Purushothaman, P. Thankachan, Hertz contact stress analysis and validation using Finite Element Analysis, *Int. J. Res. Appl. Sci. Eng. Technol.* 2 (XI) (2014) 531–538.
- [14] R. Gutkin, B. Alfredsson, Growth of fretting fatigue cracks in a shrink-fitted joint subjected to rotating bending, *Eng. Fail. Anal.* 15 (5) (2008) 582–596.
- [15] C.E. Truman, J.D. Booker, Analysis of a shrink-fit failure on a gear hub/shaft assembly, *Eng. Fail. Anal.* 14 (4) (2006) 557–572.
- [16] W.J. Grant, Shrink fitting, *Cryogenics* 12 (4) (1972) 328–333.
- [17] M. MacMillan, J.L. Hendry, A. Woolley, M.J. Pavier, Measurement of partial slip at the interface of a shrink fit assembly under axial load, *Exp. Mech.* 58 (2018) 407–415.
- [18] A. Mouaa, N.E. Laghzale, A.-H. Bouzid, Elastic-plastic stresses in shrink fit with a solid shaft, *MATEC Web Conf* 286 (2019), 02001.
- [19] E. Toma, Optimization of rotor shaft shrink fit method for motor using "Robust design", *J. Ind. Eng. Int.* 14 (2018) 705–717.
- [20] T.N. Chakherlou, M. Mirzajanzadeh, B. Abazadeh, K. Saeedi, An investigation about interference fit effect on improving fatigue life of a holed, *Eur. J. Mech. Solid.* 29 (4) (2010) 675–682.
- [21] Z. Murcinková, P. Baron y, M. Pollák, Study of the press fit bearing-shaft joint dimensional parameters by analytical and numerical approach, *Ann. Mater. Sci. Eng. (2-a)* (2018) 1–10, 2018.
- [22] A. Strozzi, E. Bertocchi, A. Baldini, S. Mantovani, Normalization of the stress concentrations at the rounded edges of an interference fit between a solid shaft subjected to bending and a hub, *Mech. Base. Des. Struct. Mach.* 44 (4) (2016) 405–425.
- [23] D.H. Lee, S.J. Kwon, J.B. Choi, Y.J. Kim, Observations of fatigue damage in the press-fitted shaft under bending loads, *Key Eng. Mater.* 326–328 (2006) 1071–1074.
- [24] C. Song, M.X. Shen, X.F. Lin, D.W. Liu, M.H. Zhu, An investigation on rotatory bending fretting fatigue damage of railway axles, *Fatig. Fract. Eng. Mater. Struct.* 37 (1) (2014) 72–84.
- [25] I. 2768, «ISO 2768 general tolerances,» [online]. Available: [Last accessed: 13 July 2020, https://www.iso.org/search.html?q=iso%202768%20general&hPP=10&idp=all_en&p=0&hFR%5Bcategory%5D%5B0%5D=standard.