



Faculty of Science and Technology

MASTER'S THESIS

Study program/ Specialization: Masters of Science in Environmental Monitoring and Nature Management in the Northern Oil & Gas Producing Regions	Spring semester, 20..12.. Open / Restricted access
Writer: Hua Qin NG (Writer's signature)
Faculty supervisor: Professor Torleiv Bilstad External supervisor(s): Dr. Bjørn Rusten	
Title of thesis: Removal of MBBR Biofilm Solids by Salsnes Filter Fine Mesh Sieves	
Credits (ECTS): 30	
Key words: Biofilm Solids Separation Biomass Separation Coagulation-Flocculation MBBR Salsnes Filters Wastewater treatment	Pages:118..... + enclosure: ...54..... Stavanger, ...29 June 2012..... Date/year

REMOVAL OF MBBR BIOFILM SOLIDS BY SALSNES FILTER
FINE MESH SIEVES

HUAQIN NG

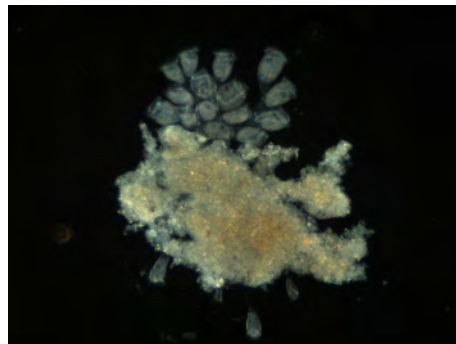

June 2012

HuaQin NG: *Removal of MBBR Biofilm Solids by Salsnes Filter Fine Mesh Sieves*, © June 2012

"To dream anything that you want to dream.

That's the beauty of the human mind.

To do anything that you want to do.

That is the strength of the human will.

To trust yourself to test your limits.

That is the courage to succeed."

— Bernard Edmonds

Dedicated to my family who have shown endless support for my
perpetual wanderlust and my desire to see the world.

ABSTRACT

Biological wastewater treatment is often used in conjunction with primary treatment to reduce the constituents in wastewater. It is normally necessary to separate the biomass from the treated wastewater in order to meet the effluent discharge standards. Moving Bed Biofilm Reactor (MBBR) is a biofilm process where plastic carriers carrying the biomass are moving along with the wastewater and typically operating with low concentration of suspended solids in pure biofilm systems. Salsnes Filters AS (SF) is a Norwegian company specializing in design, manufacturing and supply of patented fine mesh filter machines for treatment of primary wastewater and looking to expand use of their products for the separation of biofilm solids following biofilm processes.

This study describes an overall assessment of the performance of SF sieve cloths for separation of biofilm solids with and without pre-flocculation from a Norwegian municipal wastewater treatment plant, Nordre Follo Renseanlegg. The particles in the reactor effluents were characterized with a Malvern Mastersizer and with SF sieves for particle size distribution (PSD). Preliminary jar test trials were performed in order to obtain an optimal dosage of flocculant, mixing and flocculation conditions for subsequent pilot scale testing. The efficiency of two flocculants (cationic polymer based flocculant Superfloc C496 and polyaluminium hydroxide based flocculant, PAX XL-60) was evaluated at pilot scale flocculation. 10 different SF sieve cloth with light opening ranging from 11 μm to 500 μm were tested.

The results indicate that PSDs vary according to the organic loading on the individual reactors with higher organic loading resulting in smaller particle volumes and the particle size peaked around

100 μm in diameter. The results also indicate SF sieves can be used for MBBR biofilm solids separation with and without pre-flocculation. SS and COD removal efficiencies of SF sieves cloths for unflocculated reactor effluent increased with increasing HRT, decreased organic loading and decreasing light opening of the sieves. The formation of a mat on the sieve cloth during filtration was found to lead to reduced SS removal for some sieves and the mat were found to be clogged quickly after formation. Higher hydraulic capacities lead to lower SS removal efficiencies in most cases and the hydraulic capacities decreased with decreasing light opening.

Flocculation changed the particle size characteristics of the reactor effluent and the hydraulic capacities of the sieve cloths. Flocculating with Superfloc C496 shifted PSD towards larger size range and the SS removal efficiency improved for SF sieves in the larger light opening ranges but resulted in reduced hydraulic capacities. Flocculating with PAX XL-60 increased the percentage of smaller particle sizes, lowered overall SS removal efficiencies with negative removal in the larger light opening ranges and lowered hydraulic capacities.

Online characterization of flocculation enabled the flocculation time during pilot scale flocculation studies to be optimised. It was found that with Superfloc C496, the minimum flocculation time for the maximum floc size to be achieved is 6 minutes whereas with PAX XL60, the minimum flocculation time is 9 minutes. Image analysis of the flocs also suggest stirrer design and flocculant have an influence on the shape and structure of the flocs.

ACKNOWLEDGMENTS

The completion of this research would not have been possible without the kind assistance and continual guidance and support of various people and organisations.

First and foremost, my sincere gratitude to my supervisor, Professor Torleiv Bilstad for taking a chance on me and giving me the opportunity to work with Aquateam and Salsnes Filter.

Secondly, thanks are due to my external supervisor, Dr Bjørn Rusten for accepting me as his student and for his guidance throughout my work at Aquateam. My sincere appreciation to my mentor at Aquateam, Dr Ashish Sahu, for his assistance and advice with my experiments and for his valuable inputs to my thesis.

I would also like to thank all the wonderful people at Aquateam for making my stay in Oslo so wonderful. My thanks especially to Dr Eilen A. Vik, Mr Arne Lundar and Ms Ocelie Kjønne for their kind assistance and guidance in the laboratory and to Ms Mona Falkum for arranging my wonderful accommodation in Oslo.

Lastly, I would like to thank my family and friends who have supported and/or helped me in one way or another during the course of this research project. Special thanks are due to my good friend Stian Breivik for providing me with healthy competition during the course of my studies.

CONTENTS

I INTRODUCTION	1
1 BIOFILM SOLIDS SEPARATION AND SALSNES FILTERS	2
1.1 Introduction	2
1.2 Overview	4
1.3 Objectives	4
II LITERATURE REVIEW	6
2 BIOLOGICAL WASTEWATER TREATMENT	7
2.1 Biofilms	7
2.2 Biofilm Reactors	9
2.2.1 Trickling Filters	9
2.2.2 Rotating Biological Contactors	10
2.2.3 Moving Bed Biofilm Reactors	12
2.3 Nordre Follo Sewage Treatment Plant	13
3 PHYSIOCHEMICAL PROCESSES	17
3.1 Physical Solid-Liquid Separation for MBBR Effluents .	17
3.1.1 Sedimentation	17
3.1.2 Microscreening	18
3.1.3 Salsnes Filter Fine Mesh Rotating Belt Sieves . .	20
3.2 Coagulation and Flocculation	22
3.2.1 Coagulation	22
3.2.2 Flocculation	23
3.2.3 Coagulation and Flocculation for Suspended Solids Removal	27
III MATERIALS AND METHODS	28
4 EQUIPMENT AND MATERIALS	29
4.1 Dr. Lange DR 5000 Spectrophotometer	29

4.2	Chemical Oxygen Demand Analysis with Dr. Lange Cuvette Kits	29
4.3	Phosphate Analysis with Dr. Lange Cuvette Kits	31
4.4	Chemicals and Polymers for Flocculation	33
4.5	Jar Test Kemira Kemwater Flocculator	33
4.6	Malvern Mastersizer 3000	33
4.7	Microscope	39
4.8	Hach 2100P Portable Turbidity Meter	39
4.9	pH Meter	39
4.10	Benchscale Salsnes Filter Test Apparatus	39
4.11	Pilot scale Flocculation	40
5	METHODOLOGIES	44
5.1	Polymer preparation	44
5.2	MBBR Effluent sampling	44
5.3	Solids Analysis	45
5.3.1	Total Suspended Solids	45
5.3.2	Biomass on Carriers	45
5.3.3	Particles Screening Test using Salsnes Bench Scale Test Apparatus	46
5.3.4	Particle Size Distribution using Malvern Mas- tersizer 3000	46
5.3.5	Particle Size Distribution during flocculation us- ing Malvern Mastersizer 3000	47
5.4	Chemical Oxygen Demand Measurement	49
5.5	Phosphate Measurement	49
5.6	Initial Flocculant Screening Jar Test	50
5.7	Flocculant Dosing Jar Test	50
5.8	Mixing Optimisation With Jar Test	51
5.9	Pilot Scale Flocculation	52
5.9.1	Floc size changes during pilot scale flocculation	52
5.9.2	Pilot Scale Flocculation for Superfloc C-496 . . .	53
5.9.3	Pilot Scale Flocculation for PAX XL-60	54

IV RESULTS AND DISCUSSIONS	56
6 RESULTS AND DISCUSSIONS	57
6.1 Wastewater and MBBR Effluent Characteristics	57
6.1.1 Flow and Load to Nordre Follo Renseanlegg . .	57
6.1.2 Particle Size Distribution for Nordre Follo MBBR Reactors	59
6.2 Initial Flocculant Screening using Jar Test	60
6.3 Flocculant Dosage Optimisation in Jar Test	63
6.4 Flocculation Optimisation in Jar Test	65
6.4.1 Effects of Mixing Intensities and Mixing Times	67
6.4.2 Effects of Flocculation Intensities and Floccula- tion Times	67
6.4.3 Combined Effects of Mixing and Flocculation .	69
6.5 Pilot Scale Flocculation	70
6.5.1 Stirrer Types and approximated G-values	70
6.5.2 Flocculation Timing	71
6.5.3 Biofilm solids and Flocc Images	73
6.6 Benchscale Salsnes Filter Test Apparatus	75
6.6.1 Application to NFR MBBR Reactor Effluent . .	76
6.6.2 Application to Flocculated NFR MBBR Reactor 5 Effluent	82
V CONCLUSIONS AND FUTURE WORKS	93
7 CONCLUSIONS	94
7.1 Conclusions	94
7.2 Recommendations for future works	96
REFERENCES	97
VI APPENDIX	102
A STANDARD PROCEDURES	103
A.1 AWWA Standard Methods for Water and Wasterwater Analysis 2540D	103

A.2	Working Procedure for LCK 414	108
A.3	Working Procedure for LCK 614	113
A.4	Working Procedure for LCK 349	118
A.5	Salsnes Filters Bench Scale Filter Test Apparatus	123
A.6	Standard Operating Procedure for Malvern Mastersizer 3000	128
B	SUPPORTING DATA	138
B.1	Assumed Volume Filtered With Salsnes Filters without mat formation at 30 seconds filtration time	138
B.2	Removal Efficiencies and mean hydraulic capacity of SF sieves for NFR MBBR R5 Effluent without mat for- mation	140
B.3	Suspended Solids Distribution of Flocculated NFR MBBR Reactor 5 Effluent (Original Data)	140
C	MATERIAL SAFETY DATA SHEETS	143
C.1	MSDS	143

LIST OF FIGURES

Figure 2.1	Stages of biofilm growth and typical features of biofilm (Costerton et al., 2003)	9
Figure 2.2	Kaldnes Carriers (AnoxKaldnes)	13
Figure 2.3	Overall schematic process flow for Nordre Follo Wastewater Treatment Plant. Adapted from NFR (2012)	14
Figure 2.4	Process flow for NFR MBBR (NFR)	16
Figure 3.1	Implementations of microscreening	18
Figure 3.2	Cross sectional view of Salsnes Filter machine (Salsnes Filter AS)	21
Figure 4.1	Dr Lange DR 5000 Spectrophotometer (Hach-Dr.Lange)	31
Figure 4.2	Kemira Kemwater Flocculator	35
Figure 4.3	Correlation of mixing speeds and G-values of Kemira flocculator	36
Figure 4.4	Malvern Mastersizer 3000 (Malvern)	37
Figure 4.5	Benchscale Salsnes Filter Test Apparatus: (a) Setup of the apparatus for sample, and (b) sketch of the apparatus.	41
Figure 4.6	Pilot scale flocculation setup	42
Figure 4.7	Stirrers used for pilot scale flocculation	43
Figure 5.1	Schematic flow of Line 2 of NFR with sampling locations indicated (as shown using the red arrows). Biomass carriers were sanpled from all the reactors (Reactor 1 through Reactor 7) during the period of this study.	45

Figure 5.2	Setup for PSD analysis with Malvern Mastersizer 3000 (sampling from flocculation jar test)	47
Figure 5.3	Setup for PSD analysis with Malvern Mastersizer 3000 during pilot scale flocculation . . .	49
Figure 5.4	Protocol for mixing optimisation with jar test .	52
Figure 6.1	Wastewater flow to NFR MBBR during the experimental period	58
Figure 6.2	Weather conditions at Ås municipality (source: www.yr.no)	58
Figure 6.3	Variation of biomass on carriers for various NFR MBBR reactors	59
Figure 6.4	Particle size distribution in effluents of 7 MBBR reactors in Nordre Follo WWTP	60
Figure 6.5	Suspended solids size distribution from Salsnes Filters Test Apparatus	61
Figure 6.6	Turbidity removal for Reactor 5	62
Figure 6.7	Turbidity removal for Reactor 7	62
Figure 6.8	TSS removal for NFR Line Reactor 5 effluent using varying doses of flocculants: (a) Flocculation done with only one flocculant, and (b) flocculation with a combination of flocculants	66
Figure 6.9	TSS removal with varying flocculation mixing settings	68
Figure 6.10	Floc size variation during flocculation with polymer (Superfloc C-496K). The floc size refers to volumetric equivalent diameter at DV ₅₀ as analysed by Malvern Mastersizer 3000. SM refers to flocculation mixing.	72
Figure 6.11	Settling of flocs during flocculation with Superfloc C-496 and the silver stirrer. The settled flocs are visible as a ring around the stirrer and of a darker color compared to the bulk liquid.	72

Figure 6.12	Floc size variation during flocculation with polymer (PAX XL-60). The floc size refers to volumetric equivalent diameter at DV ₅₀ as analysed by Malvern Mastersizer 3000. SM refers to flocculation mixing.	73
Figure 6.13	Settling of flocs during flocculation with PAX XL-60 and silver stirrer. The settled flocs are visible as a ring around the stirrer and of a darker color compared to the bulk liquid. . . .	74
Figure 6.14	Biofilm solids in NFR Reactor 5 MBBR Effluent	74
Figure 6.15	Flocs formed from flocculation of NFR reactor 5 effluent with Superfloc C-496	75
Figure 6.16	Flocs formed from flocculation of NFR reactor 5 effluent with PAX XL-60	76
Figure 6.17	SS Removal Efficiencies with SF Sieves for NFR MBBR R ₅ Effluent	77
Figure 6.18	COD Removal Efficiencies with SF Sieves for NFR MBBR R ₅ Effluent	78
Figure 6.19	Variation of particulate COD in different NFR MBBR reactor effluent	79
Figure 6.20	Removal efficiencies and mean hydraulic capacity of SF sieves for NFR MBBR R ₅ Effluent with mat formation.	80
Figure 6.21	Removal Efficiencies and mean hydraulic capacity of SF sieves for NFR MBBR R ₅ Effluent without mat formation	83
Figure 6.22	SS Removal Efficiencies with SF Sieves for polymer flocculated NFR MBBR reactor 5 effluent .	84
Figure 6.23	SS Removal Efficiencies with SF Sieves for PAX flocculated NFR MBBR reactor 5 effluent . . .	85

Figure 6.24	COD Removal Efficiencies with SF Sieves for polymer flocculated NFR MBBR reactor 5 effluent	86
Figure 6.25	COD Removal Efficiencies with SF Sieves for PAX flocculated NFR MBBR reactor 5 effluent	86
Figure 6.26	Suspended solids size distribution from Salsnes Filters Test Apparatus	88
Figure 6.27	Removal Efficiencies and mean hydraulic capacity of SF Sieves for flocculated MBBR effluent with mat formation. PAX refer to PAX XL-60 and Poly refers to Superfloc C496.	89
Figure 6.28	Comparison of mean hydraulic capacity of SF sieves for unflocculated and flocculated MBBR effluent with mat formation	90
Figure 6.29	Removal Efficiencies and mean hydraulic capacity of SF Sieves for flocculated MBBR effluent without mat formation	91
Figure 6.30	Comparison of mean hydraulic capacity of SF sieves for unflocculated and flocculated MBBR effluent with mat formation	92
Figure B.1	Removal Efficiencies and mean hydraulic capacity of SF sieves for NFR MBBR R5 Effluent without mat formation	141
Figure B.2	Suspended solids size distribution from Salsnes Filters Test Apparatus for NFR MBBR R5 Effluent	142

LIST OF TABLES

Table 2.1	Classification of trickling filters ^a	11
Table 2.2	Typical process design parameters for a MBBR with nitrogen removal ^a	14
Table 2.3	Key design parameters of the Kaldnes Moving Bed biofilm process	15
Table 3.1	Typical overflow rates for secondary settling tanks	19
Table 3.2	Influence of light opening of screens, influent SS on filtration rates of Discfilters ^a	20
Table 3.3	Technical data for Salsnes Filters machines	21
Table 3.4	Characteristics of destabilization mechanisms with coagulation ^a	24
Table 4.1	Key technical data for DR 5000	30
Table 4.2	Dr. Lange cuvette kits and the associated measuring range and principles	32
Table 4.3	Type of flocculants used in the screening experiment.	34
Table 4.4	Kemira Flocculator mixing speeds and their associated G-values	36
Table 4.5	Key Specifications of Malvern Mastersizer 3000	38
Table 5.1	Analysis procedure for biofilm solids Particle Size Distribution (PSD) with Malvern Mastersizer 3000	48
Table 5.2	Flocculants and final dosing concentrations used for jar test	51
Table 5.3	Mixing protocol and approximated G-values for pilot-scale flocculation	53

Table 5.4	Mixing protocol and approximated G-values for pilot-scale flocculation with Superfloc C-496	54
Table 5.5	Mixing protocol and approximated G-values for pilot-scale flocculation with PAX XL-60 . . .	55
Table 6.1	Flocculants and doses selected from screening study for further studies	64
Table 6.2	NFR Line 2 Reactor 5 MBBR Effluent SS concentration variation	65
Table 6.3	Power Consumption of pilot scale flocculation	70

ACRONYMS

BOD	Biological Oxygen Demand
COD	Chemical Oxygen Demand
EPS	Extracellular Polymeric Substances
HRT	hydraulic retention time
MBBR	Moving Bed Biofilm Reactor
MSDS	material safety data sheets
NFR	Nordre Follo Renseanlegg (Nordre Follo Wastewater Treatment Plant)
PCOD	Particulate Chemical Oxygen Demand
PSD	Particle Size Distribution
SF	Salsnes Filter
SS	Suspended Solids
RBC	Rotating biological contactors

rpm revolutions per minute

TOC Total Organic Carbon

UV/Vis Ultraviolet and Visible

Part I

INTRODUCTION

BIOFILM SOLIDS SEPARATION AND SALSNES FILTERS

1.1 INTRODUCTION

Biological treatment is a form of engineered secondary treatment in conventional wastewater treatment since its first documented use in 1893 in Salford near Manchester in the UK (Henze et al., 2008). The key objectives of biological treatment are to reduce the constituents of wastewater through (1) oxidation of dissolved and particulate biodegradable organic matter into more acceptable end products, (2) capture and incorporation of Suspended Solids (SS) and non-settleable solids into biological flocs or biofilm and (3) sequestering of nutrients such as nitrogen, phosphorus and sulphur (Grady et al., 1999; Tchobanoglous et al., 2003).

The two predominant forms of biological wastewater treatment are the use of suspended growth (activated sludge) and attached growth (biofilm) processes. The key difference between the two processes lies in the form of growth of biomass: in activated sludge processes, the biomass is not attached to any surface and completely suspended in the liquid phase whereas in biofilm processes, growth of biomass occurs as biofilm attached on surfaces. In activated sludge processes, the removal of organics and nutrients from the wastewater depends on the concentration of sludge in the reactor. The typical biomass concentration lies between 1.5 to 6 g/l of SS (Ekama and Wentzel, 2008). For biofilm processes, the removal of organics and nutrients depends on the organic loading rates (surface, B_A and volumetric,

B_V) and typical B_A ranges from 1 to 20 $\text{g}/\text{m}^2 \cdot \text{d}$ of Biological Oxygen Demand (BOD) (Morgenroth, 2008).

Following biological treatment, it is necessary to separate the biomass from the treated wastewater in order to meet the effluent discharge standards. Owing to the high concentration of SS in activated sludge processes, secondary clarifiers are typically installed to separate biomass and to concentrate the sludge for recycle (Tchobanoglous et al., 2003). In contrast, SS in effluent of attached growth processes are in the range of 150 - 250 mg/l and the common separation processes/technologies include settling, micro-screening, media filtration, membrane filtration and flotation (Ødegaard et al., 2010).

Coagulation and flocculation through the use of chemicals or polymers to achieve better solids separation through increasing larger floc sizes are utilised in drinking water and wastewater treatment. They are not typically used in secondary clarification of activated sludge since activated sludge flocs are larger and under normal operating conditions, settle well. Flocculation is typically used in biofilm processes to increase the floc sizes for enhanced SS separations (Ødegaard et al., 2010) .

Salsnes Filter (SF) is a Norwegian company specializing in design, manufacturing and supply of patented fine mesh filter machines for treatment of primary wastewater from the municipal as well as industrial origins. The SF machines are designed to operate under varying hydraulic loads and organic loads without operator intervention for cleaning of the mesh. SF machines have been used successfully in Norway for the treatment of primary wastewater and for removal of SS from industrial wastewater (Rusten and Ødegaard, 2006). SF is looking into expand the use of their solids separation technology in the secondary and tertiary wastewater treatment market, especially in combination with biofilm biological reactors.

1.2 OVERVIEW

This thesis contains five parts. The first part presents the introduction to the field of biological wastewater treatment and the objectives of this study. Literature review of existing practices and state of the art studies on biofilm solids removal will be presented and explained in the second part. The materials and methodologies employed during this study will be presented in the third part of the thesis. The fourth part examines the results obtained from the experimental works conducted and discussions pertaining to the objectives. The final part of this thesis will conclude this thesis and suggests recommendations for future works. Appendices containing the supporting materials are included at the end of this thesis.

1.3 OBJECTIVES

This thesis deals with the characterization of biofilm solids in the wastewater from a Moving Bed Biofilm Reactor (MBBR) process and investigates the removal of these solids, with and without flocculation aids, using fine mesh sieves produced by SF. The overall objective is to investigate feasibility of application of existing SF sieves and machines for biofilm solids separation. Samplings and tests were conducted at a wastewater treatment plant near the Oslo region (Nordre Follo Renseanlegg (Nordre Follo Wastewater Treatment Plant) (NFR)) using a bench-scale SF method developed by Aquateam (Rusten and Lundar, 2006). The specific objectives of this study are:

- Characterize the biofilm solids in the effluent of MBBR process.
- Flocculation with chemical and/or polymer aids prior to particle separation.
- Characterization of particles before and after separation with SF

- Evaluate the effect of different organic loadings on the separation processes.

Part II

LITERATURE REVIEW

Literature review of existing practices and state of the art studies on biofilm solids removal is presented within this Part. The literature review is organised into 2 chapters: the first chapter (Chapter 2) focuses on biological wastewater treatment with biofilm reactors and the second chapter (Chapter 3) focuses on physicochemical processes for biofilm solids separation from MBBR effluent.

BIOLOGICAL WASTEWATER TREATMENT

2.1 BIOFILMS

In attached growth biological wastewater treatment, removal of organics and nutrients are achieved through the growth of biomass on surfaces as biofilms. Biofilms are the result of the colonization of bacteria on surfaces (substratum) through production of a matrix of Extracellular Polymeric Substances (EPS) and the embedding of the bacteria within a matrix of EPS (Donlan, 2002; Madigan et al., 2011; Watnick and Kolter, 2000). Formation of biofilm occurs in stages :

- A. Reversible attachment of suspended single cells onto a substratum : Suspended cells may contact a surface through random collisions and the collisions may result in temporary attachment of the cells to the surface. The mechanisms of temporary attachment of the cells are influenced by (a) the surface charge interaction between the cell and the substratum, (b) the hydrophobicity of both the cells and substratum surface, (c) roughness of the substratum surface, (d) presence of a conditioning film on the substratum, (e) presence of external cellular protein appendages (pilia and flagella) and (f) properties of the bulk fluid such as flow velocity and temperature (Donlan, 2002).
- B. Irreversible attachment of attached single cells on the surface: Upon the temporary attachment to a substratum, the suspended cells will “sense” if the substratum is suitable for biofilm growth through a mechanism that has yet to be discovered (Madigan et al., 2011). When a suitable substratum is “sensed”, single

cells typically activate genes specific to biofilm growth mode and typically lose external cellular appendages to become non-motile. In biofilm growth mode, genes responsible for synthesis of intercellular signaling and EPS production are activated and resulting in irreversible attachment to the substratum.

- c. Growth (Colonization) of biofilm: Biofilms are composed principally of microbial cells and EPS with the latter comprising up to 90% of the Total Organic Carbon (TOC) of biofilms. The characteristics of EPS is highly variable in chemical and physical properties and is dependent on the ecology of the biofilm. EPS is highly hydrated with regions of both hydrophilic and hydrophobic properties. Two properties of the EPS reported to have a marked influence on the biofilm are (1) the composition and structure of the polysaccharides and (2) the spatial and temporal variation of the EPS. The attached cells undergo sessile growth initially on the substratum and colonize the substratum. Growth of the biofilm into the bulk phase occurs when the surface is completely colonized and with attachment of more suspended cells into the biofilm. Internal and external processes control the architecture of the biofilm resulting in structures that changes with time.
- d. Maturation of biofilm: The basic structural unit within a biofilm is the microcolony and the interaction within the ecology of the microcolony affect the composition and structure of the biofilm. The thickness of the biofilm has been shown to be affected by the number of component organisms within the microcolony and interaction between the organisms through predation, competition and cooperation. A mature biofilm is heterogenous in nature with microstructures such as voids, channels and streamers. The thickness of a mature biofilm is maintained through the growth of cells within the biofilm and the dispersal of cells from

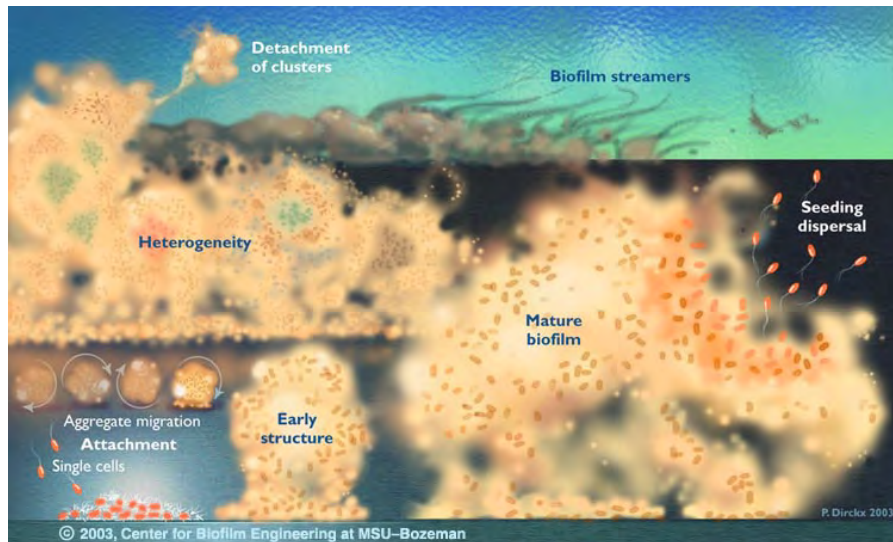

Figure 2.1: Stages of biofilm growth and typical features of biofilm (Coster-ton et al., 2003)

the biofilm. Dispersal of cells may occur through (1) shedding of daughter cells, (2) detachment of biofilm cells as a result of stress or quorum sensing and/or (3) shearing of biofilm at the biofilm-bulk interface.

2.2 BIOFILM REACTORS

Reactors utilising biofilm for removal of organics and nutrients have been used in industrial and municipal wastewater treatment. The following sections will introduce some fixed bed and biofilm reactors and their applications.

2.2.1 *Trickling Filters*

Trickling filters are a class of fixed bed biofilm reactors. A trickling filter is constructed as a tank filled with packing materials of rocks or other synthetic materials over which wastewater is distributed continuously and uniformly. The depth of the packing material depends

on the material and hydraulic loading and ranges from 0.9 to 12.2 metres. The classical classification of trickling filters and their key design parameters are summarized in Table 2.1 (Wiesmann et al., 2007; Tchobanoglous et al., 2003; Grady et al., 1999).

Biofilm forms attached on the surface of the packing materials and form the slime layer and is responsible for organics and nutrient removal from the wastewater as the wastewater flows over the packing material. The slime layer thickness can grow to as thick as 10 mm, which limits the amount of substrate that can penetrate the biofilm before being fully consumed. Consequently, the microbial cells in deeper within the biofilm can undergo endogenic respiration as well as utilising the EPS, weakening the strength of biofilm. Sloughing (bulk detachment of the slime) occurs when the shear velocity is higher than the attachment forces. Hence, the quantity and size of biofilm solids from a trickling filter is a function of wastewater characteristics and reactor hydraulic and organic loading. With lower organic loading, less biomass will be produced because larger amount of particulate BOD is degraded and the biomass has longer solids retention time (Tchobanoglous et al., 2003).

2.2.2 *Rotating Biological Contactors*

Rotating biological contactors (RBC)s are another class of fixed bed biofilm reactors. The key difference in operating principle from trickling filters lies in the movement of material. With trickling filters, fluids (wastewater and air) are in motion through the stationary biofilm support material, whereas in RBCs, the biofilm support material is moving. The typical RBC consists of a series of circular plates mounted on a horizontal shaft and partially submerged (35-90%) in wastewater and rotated through it at a speed between 0.5 to 5.0 revolutions per minute (rpm) (Tchobanoglous et al., 2003; Wiesmann et al., 2007).

Table 2.1: Classification of trickling filters^a

Design Characteristics	Low or Standard Rate	Intermediate Rate	High Rate	High Rate	Roughing
Type of packing	Rock	Rock	Rock	Plastic	Rock/Plastic
Hydraulic Loading ($m^3/m^2 \cdot d$)	1-4	4-10	10-40	10-75	40-200
Organic Loading ($kg - BOD/m^3 \cdot d$)	0.07-0.22	0.24-0.48	0.4-2.4	0.6-3.2	>1.5
Sloughing	Intermittent	Intermittent	Continuous	Continuous	Continuous
Depth (m)	1.8-2.4	1.8-2.4	1.8-2.4	3.0 - 12.2	0.9 - 6
BOD Removal Efficiency (%)	80-90	50-80	50-90	60-90	40-70

^aAdapted from Tchobanoglous et al. (2003)

Biofilm forms on both surfaces of the circular plates which can be up to 3.65 metres in diameter and typically produced with lightweight plastic materials such as polyethylene and polyurethane. The surface area of the circular plates on a single shaft which biofilm can grow on ranges from 9300 m² in the low density assembly to 16,700 m² in the high density assembly. During rotation through air, the wastewater and biofilm is aerated and the wastewater drips through the plates. Sloughing and detachment of biofilm from the plates occur during normal operation (Grady et al., 1999; Tchobanoglous et al., 2003; Wiesmann et al., 2007).

2.2.3 *Moving Bed Biofilm Reactors*

MBBR was invented by Professor Hallvard Ødegaard in Norway for the treatment of wastewater using a reactor containing biomass growing as biofilm on small plastic elements moving freely within the reactor (Ødegaard, 1996). The key features of the MBBR (Ødegaard et al., 1994) are

- continuously operated
- non-cloggable biofilm reactor
- low head-loss
- high specific biofilm surface

In order to achieve the features, the reactors are designed as a continuous flow stirred tank reactor with biomass/biofilm growing on polyethylene carrier media (Figure). The media is kept completely mixed via aeration in aerobic reactors and via mechanical mixers in anoxic and anaerobic reactors (Ødegaard et al., 1994). When an empty reactor is filled up to a maximum 70% (volumetric filling), the maximum effective specific biofilm growth area will be ca. 350 m²/m³.

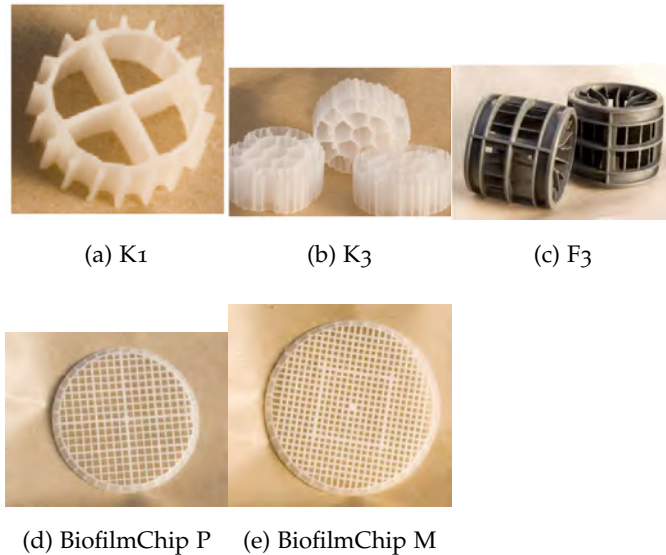

Figure 2.2: Kaldnes Carriers (AnoxKaldnes)

Typical process design parameters for [MBBRs](#) are presented in [Table 2.3](#).

2.3 NORDRE FOLLO SEWAGE TREATMENT PLANT

Nordre Follo sewage treatment plant ([NFR](#)) was constructed in 1972 to provide only primary treatment of sewage from three municipalities (Ski, Oppegård and Ås) located 30 kilometres south of Oslo, Norway. The plant was subsequently upgraded in 1982 with chemical precipitation in combination with flotation for effluent polishing prior to discharge. The plant was further upgraded in 1997 with secondary biological wastewater treatment for nitrogen and [BOD](#) removal through the installation of a [MBBR](#) (Kaldnes Moving Bed biofilm process). The overall process of [NFR](#) is illustrated in [Figure 2.3](#) ([NFR, 2012](#)).

In order for the plant to meet the targeted 70% removal of nitrogen (annual average) and 90% removal of [BOD](#), the [MBBR](#) was designed to combine both pre- and post-denitrification processes within 7 reactors. The key design parameters of the plant (for one line) is listed in

Table 2.2: Typical process design parameters for a MBBR with nitrogen removal^a

Parameter	Units	Range of values
Anoxic Retention Time	h	1.0 - 1.2
Aerobic Retention Time	h	3.5 - 4.5
Biofilm area ^b	m ² /m ³	200 - 1000
BOD Loading	kg/m ³ /d	1.0 - 1.4
Secondary Clarifier Hydraulic Application Rate	m/h	0.5 - 0.8

^aAdapted from Tchobanoglous et al. (2003)

^bAdapted from Löfqvist and Welander (2007); Ødegaard et al. (2000); Tchobanoglous et al. (2003)

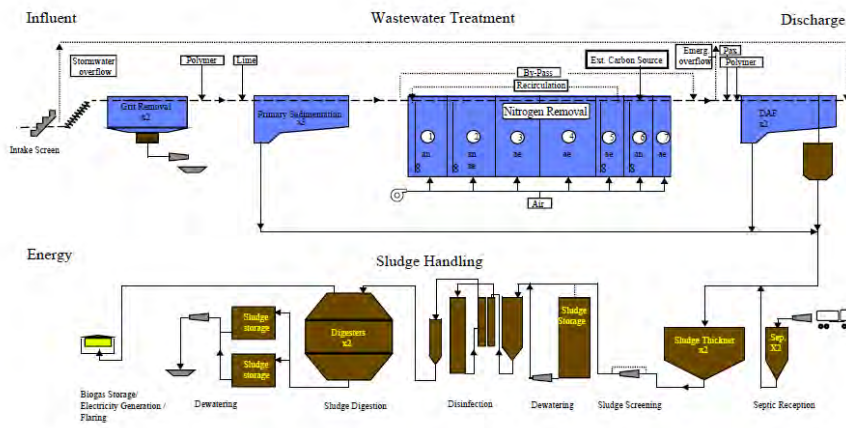

Figure 2.3: Overall schematic process flow for Nordre Follo Wastewater Treatment Plant. Adapted from NFR (2012)

Table 2.3: Key design parameters of the Kaldnes Moving Bed biofilm process

Design Load		Biomass Carrier	
Nominal Flow (m ³ /h)	750	Carrier Type	K1
Maximum Flow (m ³ /h)	1125	Nominal Diameter (mm)	9.1
Total BOD ₇ (kg/d)	2660	Nominal Length (mm)	7.2
Total COD (kg/d)	5900	Bulk Density (kg/m ³)	150
Suspended Solids (kg/d)	4390	Specific Biofilm surface area (in bulk) (m ² /m ³)	500
Total Nitrogen (kg/d)	460	Biomedia Volume (m ³)	2455
Temperature (°C)	10	Total Volume (m ³)	3710

Table (Rusten and Paulsrud, 2008). The process flow of the biological treatment is presented in Figure 2.4.

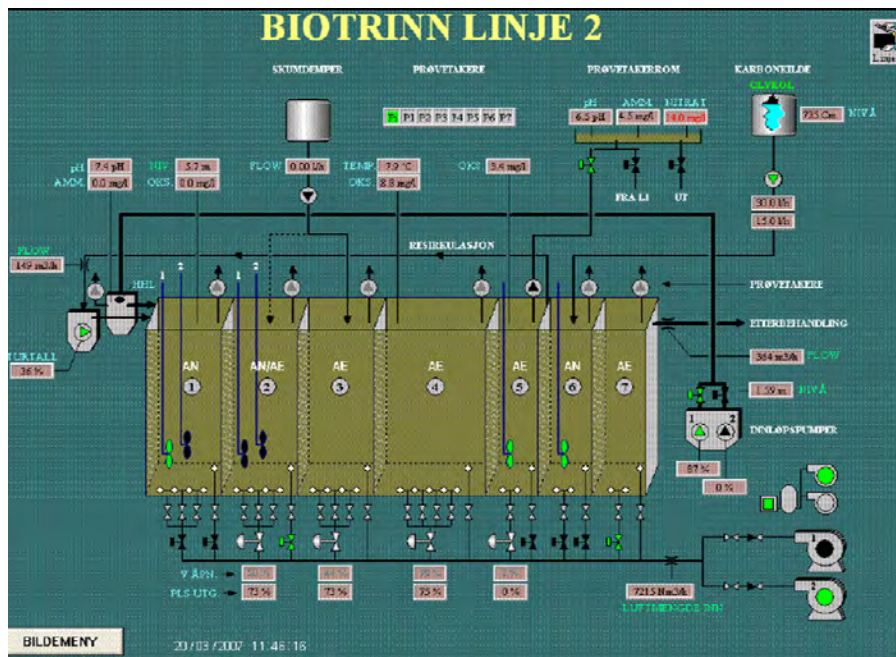

Figure 2.4: Process flow for NFR MBBR (NFR)

PHYSIOCHEMICAL PROCESSES

3.1 PHYSICAL SOLID-LIQUID SEPARATION FOR MBBR EFFLUENTS

The discharge of treated effluent from wastewater treatment plants is often regulated by laws and regulations of the localities and the concentration of *SS* is often closely monitored. Separation of *SS* from treated wastewater is hence necessary to meet the discharge quality. With secondary biological wastewater treatment, biomass is often the main form of *SS* since most larger inorganic particles would have been removed with primary treatment processes. Some typical separation processes for *MBBR* are presented in the following sections.

3.1.1 *Sedimentation*

Sedimentation is commonly used after biological wastewater treatment for separation of biomass from the treated effluent. The design and operation of secondary settling tanks are fairly established and are based on the principles of differential particle settling velocity which is expressed as

$$v = \sqrt{\frac{2g}{C_D} \frac{V_P}{A_P} \left(\frac{\rho_P - \rho}{\rho} \right)} \quad (3.1)$$

where

A_P is the cross-sectional area of the particle

C_D is the drag coefficient

ρ_P is the density of the particle

ρ is the density of the fluid

V_p is the volume of the particle

SS concentration in effluents leaving well designed secondary settling tanks can range between 5 - 15 mg/l of SS (Ekama and Wentzel, 2008). In most designs, the overflow rate from the settling tanks are used as one of the design criteria. Typical overflow rates for secondary settling tanks are presented in Table 3.1.

As discussed in Ødegaard et al. (2010), the particle size distributions in MBBR effluents can be highly variable and the use of sedimentation without pre-coagulation/flocculation can be challenging to meet effluent discharge standards.

3.1.2 Microscreening

Microscreening or microstraining is a one of many solid-liquid separation used in the water and wastewater industry for particle separation processes. Two forms of implementation of microscreening are presented in Figure 3.1. The mechanism for separation is based on the physical exclusion of particles using well defined light opening (Ljunggren, 2006; Ødegaard et al., 2010). The typical nominal light opening ranges from 10 μm to more than 100 μm (Ljunggren, 2006).

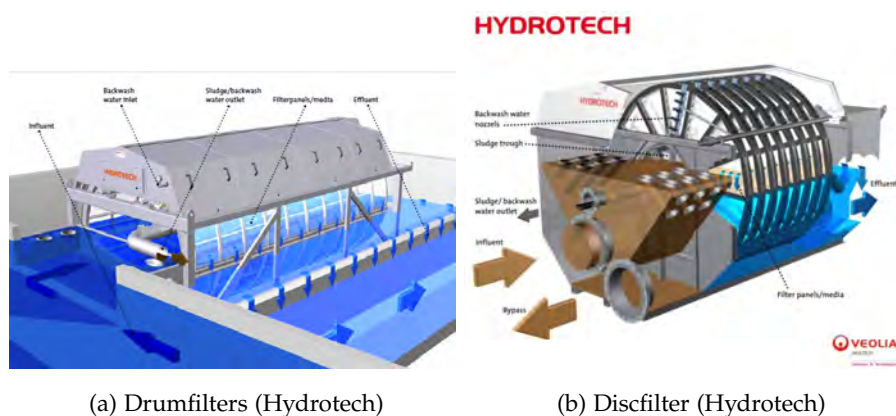

Figure 3.1: Implementations of microscreening

Table 3.1: Typical overflow rates for secondary settling tanks

Biological Treatment Type	Overflow rate ($\text{m}^3/\text{m}^2 \cdot \text{d}$)	
	Average	Peak
After air-aerated activated sludge ^a	16 - 28	40 - 64
After oxygen-aerated activated sludge ^a	16 - 28	40 - 64
After continuous phosphorus removal ^a	12 - 20	
After activated biofilter ^a		43 - 72
After biofilter/activated sludge ^a		48 - 84
After trickling filter/solids contact ^a		43 - 72
After roughing filter/activated sludge ^a		48 - 84
After MBBR without flocculation ^b	12	26.4
After MBBR with cationic polymer addition ^b	16.8	36
After MBBR with high dose metal precipitant ^b	19.2	40.8

^aAdapted from Tchobanoglous et al. (2003)

^bAdapted from Ødegaard et al. (2010)

Studies of microscreening on MBBR effluents had been conducted in Norway and Sweden at both pilot scales and full scale operations (Ødegaard et al., 2010). The results indicate the light opening of the screens and the use of coagulation/flocculation prior to screening had significant implications on the effluent quality and the filtration rates (Table 3.2). The efficiency of microscreening for SS removal ranged from 10 to 90 % again depending on the use of pre-coagulation/flocculation, light opening and the influent quality.

Table 3.2: Influence of light opening of screens, influent SS on filtration rates of Discfilters^a

Influent SS Concentration (mg/l)	Filtration Rates ($\text{m}^3/\text{m}_{\text{sieve}}^2 \cdot \text{d}$)		
	10 μm	18 μm	40 μm
27.5	115.2		
30.5		328.8	
40		192	
100 - 200			144 - 192

^aAdapted from Ødegaard et al. (2010)

3.1.3 Salsnes Filter Fine Mesh Rotating Belt Sieves

The SF fine mesh rotating belt sieve was invented by Salsnes Filter AS for the treatment of municipal and industrial wastewater. The machines are designed for the physical separation of particulate matters from primary wastewater based on physical size exclusion with fine mesh sieves. The typical nominal light opening of the sieves ranges from 50 μm to 4000 μm (Nussbaum et al., 2006).

The technical data for the different SF machines are given in Table 3.3 (Rusten, 2012).

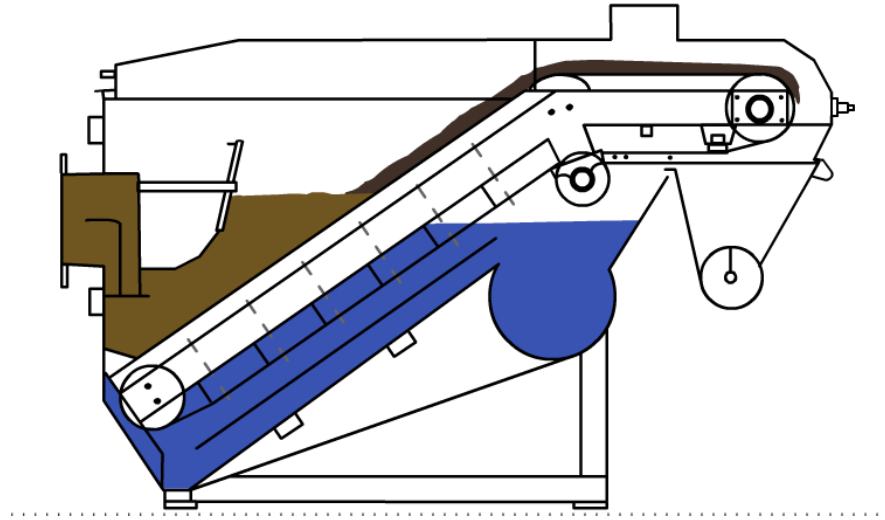

Figure 3.2: Cross sectional view of Salsnes Filter machine (Salsnes Filter AS)

	SF2000	SF4000	SF6000
Capacity (at 250 mg/l) (l/s)	20 - 40	50 - 80	100 - 140
SS Separation efficiency (%)	40 - 70	40 - 70	40 - 70
Sieve Cloth Speed (m/min)	1.5 12	1.5 12	1.5 12
Submerged Cloth Area (m ²)	0.5	1	2.2

Table 3.3: Technical data for Salsnes Filters machines

The SF machines have been used successfully in Norway for the primary treatment of municipal wastewater with TSS removal efficiencies between 72 to 90% (Nussbaum et al., 2006). SF machines are also used for the separation of solids from industrial wastewater such as fish farming, brewery and pulp manufacturing (Nussbaum et al., 2006; SalsnesFilter, 2012).

3.2 COAGULATION AND FLOCCULATION

Coagulation and flocculation are typical chemical processes within the water and wastewater treatment industries. Coagulation may be defined as the process whereby a given system may be transformed from a stable to unstable state and flocculation may be defined as the process whereby the manifested destabilization is realised in practicable terms (Bratby, 2006). For our investigation of biofilm solids separation from MBBR effluent, coagulation is the process in which small flocs of biofilm solids are formed upon rapid mixing with a chemical and flocculation is the process in which larger flocs are formed during slow mixing and by which the characteristics of the flocs are influenced. The 3 principle processes in creating larger flocs are (1) destabilization of the biofilm solids and elimination of repulsion forces between particles; (2) floc formation and growth and (3) breakage of flocs.

3.2.1 *Coagulation*

Coagulation may also be described as the process of chemically altering the surface of particles so that they are able to go close to each other and form larger particles (Jarvis et al., 2005). The process of coagulation may be achieved via one or more of the following mechanism: particle destabilisation by electrical double layer com-

pression, adsorption destabilization, bridging and physical enmeshment of colloids within coagulant precipitates (Bratby, 2006; Droste, 1997; Tchobanoglous et al., 2003).

It is widely recognised that surface charges influence the behaviour and distribution of particles in the liquid. The Derjaguin-Landau-Verwey-Overbeek (DLVO) theory is often used to explain and quantify the stability of hydrophobic particles, in terms of energy changes when particles approach one another (Bratby, 2006; Thomas et al., 1999). Zeta potential is used as an approximate quantification of energy potential between the moving particle and surrounding liquid and is used as a parameter for quantifying colloid stability, ion adsorption studies and for characterizing particle surfaces. For destabilizing the physical double layer through compression, the ionic strength of the solution needs to be increased through participating electrolytes or non-reacting electrolytes (Bratby, 2006).

The mechanism and key characteristics for metals and polymers coagulants are summarized in Table 3.4. An indepth discussion of the various coagulants and mechanisms can be found in (Bratby, 2006; Brezonik and Arnold, 2011).

3.2.2 Flocculation

Flocculation may also be described as a physical process where transport process increases the probability of collisions between destabilised particles to form larger particles (Tchobanoglous et al., 2003). The two main flocculation mechanisms in which flocs are formed are perikinetic flocculation followed by orthokinetic flocculation and the difference between them lies in the particle sizes involved (Bratby, 2006; Tchobanoglous et al., 2003). Perikinetic flocculation is the first step in flocculation and is significant for creating flocs with floc sizes less than $1 \mu\text{m}$ in liquids with velocity gradient less than 5 s^{-1} ,

Table 3.4: Characteristics of destabilization mechanisms with coagulation^a

Parameter	Influence of indicated parameters according to mechanism				Precipitation
	Physical Double Layer	Adsorption Destabilization	Bridging		
Electrostatic interactions	Governing	Important	Insignificant		Insignificant
Chemical interactions	Absent	Important	Governing		Possible some but not essential
Zeta potential for optimum destabilization	Close to zero	May be zero	Typically not zero		May be zero
Physical properties of flocs produced	Dense, high shear strength but poor filterability in cake filtration	Flocs of highly variable shear strength and density	Flocs of 3-D structure with low shear strength but high filterability in cake filtration		Flocs of highly variable strength and density

^a Adapted from Bratby (2006)

the von Smoluchowski equation describes the number of collisions (Bratby, 2006)

$$I_{ij} = 4\pi D_{ij} R_{ij} n_i n_j \quad (3.2)$$

where

I_{ij} number of contacts per unit time between particles of radius R_i and R_j

D_{ij} mutual diffusion coefficient of particles i and j (approximately $D_i + D_j$)

R_{ij} radius of interaction of the two particles, i.e. $R_{ij} = R_i + R_j$

$n_i n_j$ respective number concentration of i and j particles

In order to increase the number of collisions as well as accounting for liquid movement through flow or mixing, orthokinetic flocculation is the controlling mechanism for achieving floc sizes larger than $1 \mu\text{m}$ with velocity gradients larger than 5 s^{-1} . 2 equations describes the collision of particles in orthokinetic flocculation: von Smoluchowski for laminar flow and Argaman and Kaufman for turbulent flow (Bratby, 2006).

The von Smoluchowski equation for rate of collision of all particles in a unit time during orthokinetic flocculation in laminar flow is given by

$$H_{ij} = \frac{4}{3} n_i n_j R_{ij}^3 \frac{dv}{dz} \quad (3.3)$$

where

$\frac{dv}{dz}$ velocity gradient in laminar flow

The Argaman and Kaufman equation for rate of collision of primary particles and flocs in orthokinetic flocculation in turbulent flow is given by

$$H_{iF} = 4\pi K_s R_F^3 n_i n_F u^2 \quad (3.4)$$

where

K_S proportionality coefficient expressing the effect of turbulence energy spectrum on the effective diffusion coefficient

R_F radius of floc

n_1, n_F number concentration of primary particles and flocs respectively

u^2 mean square velocity fluctuation, which is related to mean square velocity gradient, G .

The breakup of flocs into smaller fragments will occur when the strength of the floc is less than shear forces introduced by increased velocity gradient (Jarvis et al., 2005). The equation for describing the breakup due to shearing from the floc surface is given by Aragman and Kaufman's equation (Bratby, 2006)

$$\frac{dn_1}{dt} = B \cdot R_F^2 \frac{n_F}{R_1^2} u^2 \quad (3.5)$$

where

B breakup constant

Combining Equations 3.4 and 3.5, for a completely mixed continuous flow tank reactor at steady state is given as

$$\frac{n_0}{n_1} = \frac{1 + 4\pi \cdot \alpha \cdot K_S R_F^3 n_F u^2 T}{1 + \frac{B \cdot R_F^2 n_F u^2 T}{n_0 R_1^2}} \quad (3.6)$$

where

α fraction of particle collisions resulting in lasting flocs

n_0 number concentration of primary particles at time $T = 0$

n_1 number concentration of primary particles at time T

$\frac{n_0}{n_1}$ flocculation performance parameter

The concept of root mean square velocity gradient, G was introduced by Camp and Stein (1943) as a measurable average value to replace local velocity gradient during turbulent mixing and is given by

$$G = \sqrt{\frac{P}{\mu V}} \quad (3.7)$$

where

- P energy dissipation from mixing
- μ absolute viscosity of the liquid
- V volume of the tank

For a mechanical mixer, the power consumed by the mixer is given by (Bratby, 2006)

$$P = \phi \cdot \rho \cdot n^3 \cdot D^5 \text{ (Nm/s)} \quad (3.8)$$

where

- ϕ dimensionless power number
- ρ liquid density (kg/m^3)
- n mixer rotational speed (revolutions per second)
- D diameter of mixer impeller (m)

3.2.3 Coagulation and Flocculation for Suspended Solids Removal

Studies done by several workers have shown that coagulants and flocculants providing positively charged ions are more effective than negatively charge ions (Bratby, 2006; Ødegaard et al., 2010). Coagulation and flocculation have been implemented for treatment of domestic wastewater both upstream and downstream of the biological wastewater treatment. The TSS removal in pilot scale and pilot plants with metal coagulants range from 50% to 90% depending on the raw water characteristics and dosing capacities (Bratby, 2006). Cationic polymers have been found to be more effective in destabilizing bacterial, bacterial-algal and algal suspensions and the different mechanisms are discussed in depth in Bratby (2006).

Part III

MATERIALS AND METHODS

Part III presents the materials and methods utilised within the scope of this study. This part is organised into 2 chapters: the first chapter (Chapter 4) describes the equipment and materials acquired and used for the characterisation of wastewater, biofilm solids, flocculation and solid-liquid separation efficiencies; the second chapter (Chapter 5) describes the methodologies utilised for the characterisations.

EQUIPMENT AND MATERIALS

This chapter describes and discusses the equipment and materials used for the experiments.

4.1 DR. LANGE DR 5000 SPECTROPHOTOMETER

A Dr. Lange DR 5000 spectrophotometer (Figure 4.1a) was used for the analysis of Chemical Oxygen Demand (COD) and phosphate. The equipment is designed to carry out analysis in the Ultraviolet and Visible (UV/Vis) spectrum from 190 nm to 1100 nm using split beam optics (Figure 4.1b). Light is produced through the use of a gas-filled tungsten lamp for the visible spectrum (320 nm to 1100 nm) and a deuterium lamp for the ultraviolet spectrum (190 nm to 360 nm). The key technical data is given in Table 4.1. (Hach-Lange, 2008).

4.2 CHEMICAL OXYGEN DEMAND ANALYSIS WITH DR. LANGE CUVETTE KITS

Analysis of COD were conducted with Dr. Lange cuvette test kits LCK 414 and LCK 616. As described in ISO 15705 (ISO, 2002), COD is the volume of oxygen equivalent to the mass of potassium dichromate that reacts with the oxidisable substances in water under acidic condition for 2 hours at 148 °C. Silver sulphate is added as a catalyst and mercury sulphate is added to remove interference from chloride. Titrimetric measurement is conducted to quantify the reduction of dichromate to Cr^{3+} . The Dr. Lange cuvette test kits are a modified an-

Table 4.1: Key technical data for DR 5000

DR 5000 UV-VIS Spectrophotometer	Instrument version: 1.09 Program version: Hach 12
Source lamp	Gas-filled Tungsten (visible) and Deuterium (UV)
Operating mode	Transmittance (%), Absorbance and Concentration
Wavelength range	190 - 1100 nm
Wavelength accuracy	± 1 nm in wavelength range 200 - 900 nm
Wavelength resolution	0.1 nm
Wavelength reproducibility	< 0.1 nm
Photometric accuracy	5 mAbs at 0.0 - 0.5 Abs 1% at 0.50 - 2 Abs
Photometric linearity	< 0.5% - 2 Abs $\leq 1\%$ at > 2 Abs with neutral glass at 546 nm
Stray light	KI-solution at 220 nm > 3.3 Abs / < 0.05%



Figure 4.1: Dr Lange DR 5000 Spectrophotometer (Hach-Dr.Lange)

alytical assessment utilising the same reaction principles described in ISO 15705 but with the reduced reagents and sample volumes. Quantification of reduction is done via photometry instead of titrimetric method. (Pütz, 2010) The measuring ranges for the COD test kits used (Pütz, 2010) are listed in Table 4.2.

4.3 PHOSPHATE ANALYSIS WITH DR. LANGE CUVETTE KITS

Analysis of phosphorus was conducted with Dr. Lange cuvette test kits LCK 349. The Dr. Lange cuvette test kit follows the same measuring principles (Hach-Lange, 2008) as described in ISO 6878:2004 (ISO, 2004): (a) phosphorus is quantified spectrometrically through the reaction of orthophosphate ions with molybdate and antimony ions in an acidic solution to form antimonyl phosphomolybdate complex, which is then (b) reduced by ascorbic acid to phosphomolybdenum blue complex. The measuring range for the test kits (Hach-Lange, 2008) are listed in Table 4.2.

Table 4.2: Dr. Lange cuvette kits and the associated measuring range and principles

Cuvette Kit Number	Measuring ranges	Measuring Principles
LCK 414 LCK 614	5 - 60 mg-COD /litre 50 - 300 mg-COD /litre	Oxidizable substances react with sulphuric acid – potassium dichromate solution in the presence of silver sulphate as a catalyst. Chloride is masked by mercury sulphate. The reduction in the yellow coloration of Cr ⁶⁺ is evaluated.
LCK 349	0.05 - 1.50 mg-P/litre	Phosphate ions react with molybdate and antimony ions in an acidic solution to form an antimonyl phosphomolybdate complex, which is reduced by ascorbic acid to phosphomolybdenum blue.

4.4 CHEMICALS AND POLYMERS FOR FLOCCULATION

The flocculants used in the screening are tabulated in Table 4.3. The flocculants were obtained from local suppliers of the manufacturers in the Oslo region.

4.5 JAR TEST KEMIRA KEMWATER FLOCCULATOR

Jar testing (bench-scale testing) is commonly employed in various lab scale studies of coagulation and flocculation conditions in both academia (Väänänen et al., 2012) and operational water and wastewater treatment facilities (Tchobanoglous et al., 2003). The flocculator device Kemira Kemwater Flocculator (Figure 4.2a) built by Kemira Kemwater (Helsingborg, Sweden) was used for jar testing. The semi-automatic device consists of 6 parallel agitators controlled by a micro-processor which allows for the rapid mixing and slow stirring speeds and times to be predefined. A sketch of the agitator with a 1 litre jar is illustrated in Figure 4.2b.

The various mixing speeds and their associated G-values are present in Figure 4.3 and Table 4.4 (Søraker, 2012).

4.6 MALVERN MASTERSIZER 3000

A laser diffraction particle size analyzer (Malvern Mastersizer 3000) from Malvern Instruments (Worcestershire, United Kingdom) was used for particle size analysis (Figure 4.4). The instrument uses a 633 nm red laser and a 470 nm blue laser for measurements which allows it to cover the particle size distribution (PSD) from 10 nm to 3.5 mm (3500 µm). The key specifications of the instrument are tabulated in Table 4.5. (Malvern, 2011)

Table 4.3: Type of flocculants used in the screening experiment.

Flocculant Name	Type of Flocculant	Supplied Form	Manufacturer
Superfloc C-491K	Cationic	Powder	Kemira
Superfloc C-492	Cationic	Powder	Kemira
Superfloc C-496	Cationic	Powder	Kemira
Superfloc C-577	Cationic	Liquid	Kemira
Zetag 8125	Cationic	Powder	BASF
Zetag 7550	Cationic	Powder	BASF
Zetag 9014	Cationic	Liquid	BASF
Zetag 9046 FS	Cationic	Liquid	BASF
Zetag 9048 FS	Cationic	Liquid	BASF
Zetag 9068 FS	Cationic	Liquid	BASF

(a) Cationic Polymer Based Flocculants

Flocculant Name	Type of Flocculant	Supplied Form	Manufacturer
Superfloc A-120	Anionic	Powder	Kemira
Magnafloc 919	Anionic	Liquid	BASF
Magnafloc 155	Anionic	Liquid	BASF
Magnafloc 342	Anionic	Liquid	BASF

(b) Anionic Polymer Based Flocculants

Flocculant Name	Type of Flocculant	Supplied Form	Manufacturer
PAX XL-60	Aluminium	Liquid	Kemira
Ferric Chloride	Iron	Powder	Kemira

(c) Metallic Chemical Flocculants



(a) Controller for Kemira Flocculator

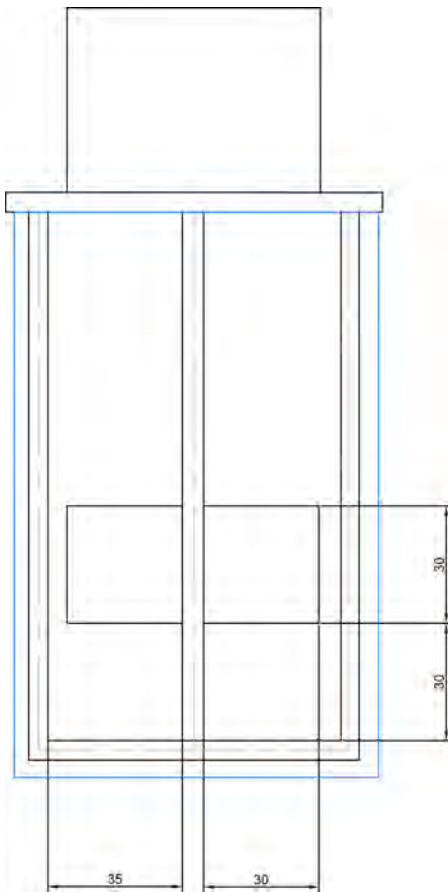

(b) Kemira Flocculator mixing device

Figure 4.2: Kemira Kemwater Flocculator

Table 4.4: Kemira Flocculator mixing speeds and their associated G-values

Revolutions per minute	G-value (s^{-1})
30	17
40	24
50	31
300	334
350	425
400	525

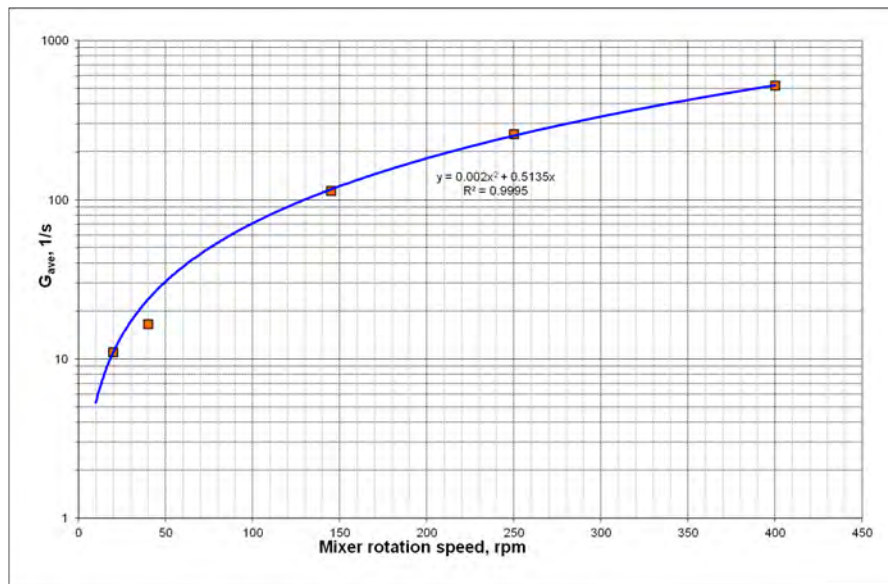
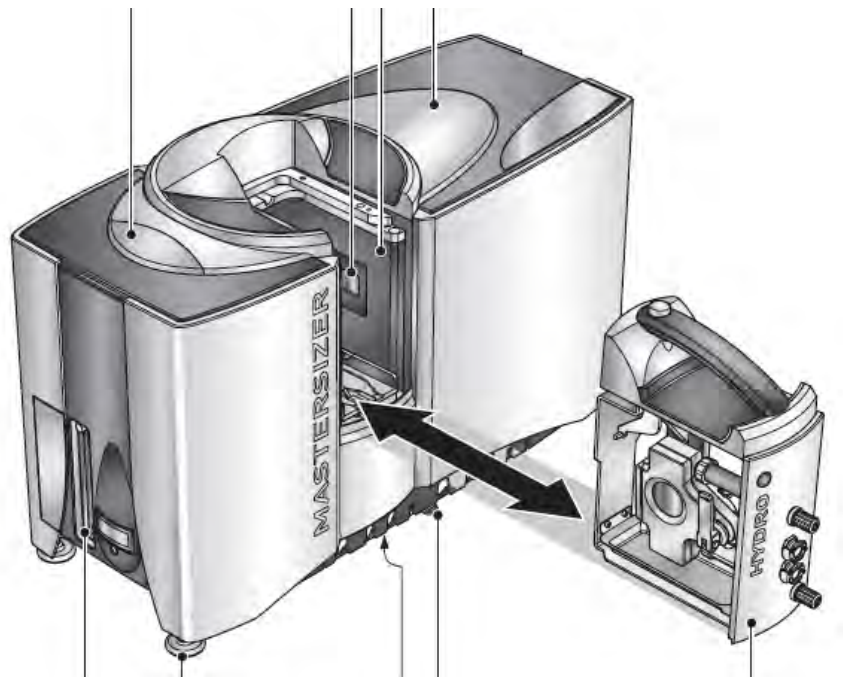
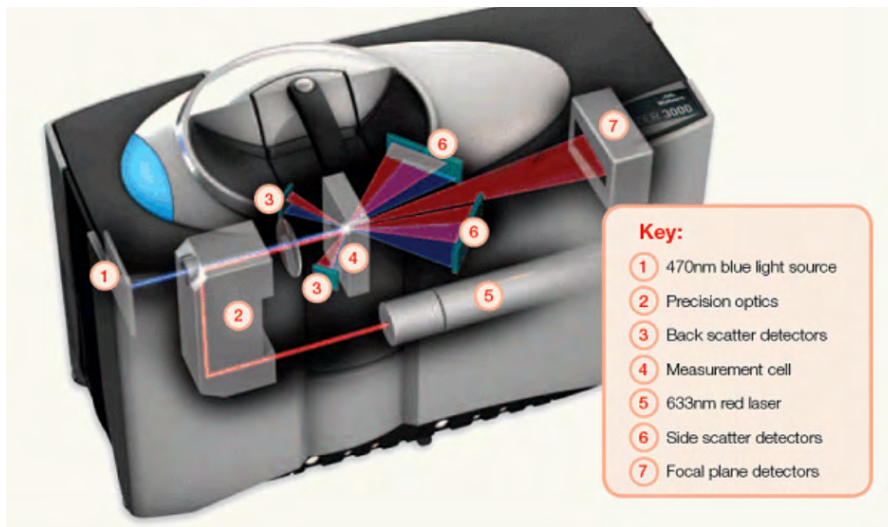

Figure 4.3: Correlation of mixing speeds and G-values of Kemira flocculator



(a) Mastersizer 3000 with wet sampling cell



(b) Optics schematics

Figure 4.4: Malvern Mastersizer 3000 (Malvern)

Table 4.5: Key Specifications of Malvern Mastersizer 3000

	Parameter	Specifications
General	Principle of Operations	Laser light scattering
	Analysis	Mie and Fraunhofer scattering
	Data acquisition rate	10 kHz
	Typical measurement time	< 10 seconds
Optics	Red light source	Max. 4 mW He-Ne, 632.8 nm
	Blue light source	Max. 10 mW LED, 470 nm
	Lens arrangement	Reverse Fourier (convergent beam)
	Effective focal length	300 mm
Detector	Arrangement	Log-spaced array Red light: Forward scattering, side scattering and back scattering. Blue light: Wide angle forward and back scattering.
	Angular range	0.015 - 144 degrees
Size	Size range	0.01 - 3500 μm
	Accuracy	Better than 1%
	Repeatability	Better than 0.5% variation
	Reproducibility	Better than 1% variation

A peristaltic pump (Watson Marlow 401U/DM3-10 - 100 rpm, Cornwall, United Kingdom) was used on the outlet port of the instrument to pump the sample for analysis.

4.7 MICROSCOPE

A Nikon Eclipse 50i optical stage microscope with attached Nikon DS-Vi1 digital camera (Nikon, Germany) was used for capturing micrographs of floc.

4.8 HACH 2100P PORTABLE TURBIDITY METER

A portable turbidity meter (Hach 2100P) from Hach Company (Germany) was used to analyse the turbidity of the MBBR effluent. The turbidity meter was calibrated for measurements up to 1000 NTU.

4.9 PH METER

A WTW SenTix 41 connected to a WTW 340i portable set (WTW, Germany) was used to analyse the pH and temperature of the MBBR effluent.

4.10 BENCHSCALE SALSNES FILTER TEST APPARATUS

The screening test apparatus developed by [Rusten \(2004\)](#) was used for the characterisation of wastewater and the solids removal efficiencies of a given fine mesh sieve. The apparatus is illustrated in [Figure 4.5 \(Rusten and Lundar, 2006\)](#). The top portion of the apparatus is designed as a reservoir to hold wastewater samples. It is constructed with transparent PVC material in order for the wastewater to be (a) measured, (b) changes in the water level to be followed during testing

and (c) for ensuring leakage through openings other than the outlet can be detected easily (Rusten and Lundar, 2006).

10 different sieve cloths supplied by Salsnes Filter AS were used for the characterization. The mesh sizes are: 500, 350, 250, 210, 150, 90, 55, 33, 18 and 11 μm .

4.11 PILOT SCALE FLOCCULATION

For the scale up of flocculation from 1 litre jar test to 20 litres flocculation, the experiment is set up as depicted in Figure 4.6. A hand drill (Cotech model HL-DR10Li-2144, Clas Ohlson AS, Norway) connected to a regulated DC power supply (Model PS603, Velleman, Belgium) was used to drive the stirrers. The 25 litres (400 mm by 400 mm by 200 mm) containers used for containing wastewater for flocculation were made of food-grade HDPE plastic. Three commercially available paint stirrers (Figure 4.7) were used for rapid mixing and slow stirring.



(a)

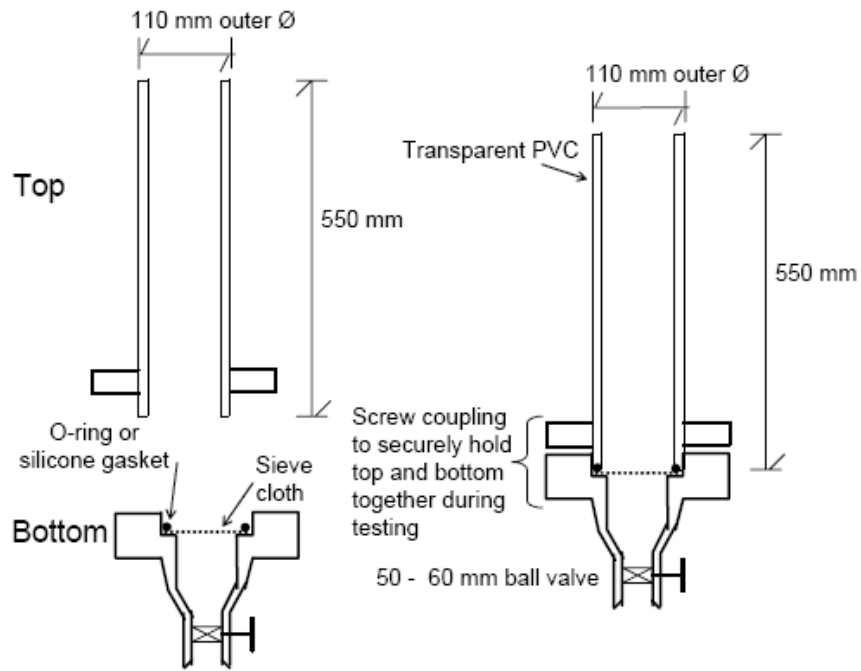

(b)

Figure 4.5: Benchscale Salsnes Filter Test Apparatus: (a) Setup of the apparatus for sample, and (b) sketch of the apparatus.

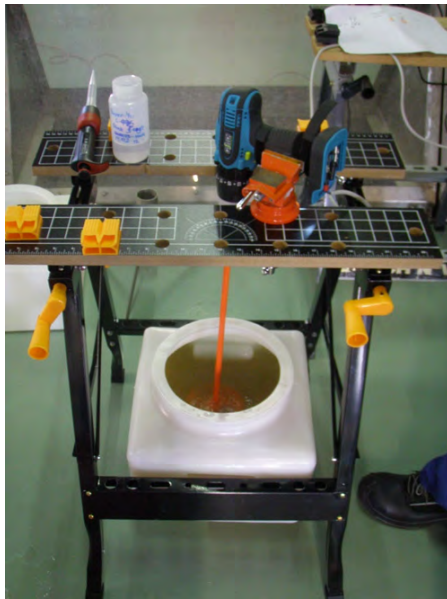

Figure 4.6: Pilot scale flocculation setup



(a) Orange stirrer: Double helix without ring at the bottom. Total length at 590 mm, length of helix at 120 mm and diameter of helix at 120 mm



(b) Red stirrer: Double ribbon with ring at the bottom. Total length at 580 mm, length of ribbon at 150 mm and diameter of ring at 115 mm



(c) Silver stirrer: Double helix with ring at the bottom. Total length at 300 mm, length of helix at 110 mm and diameter of helix at 100 mm

Figure 4.7: Stirrers used for pilot scale flocculation

METHODOLOGIES

This chapter describes and discusses the methodologies employed for the experiments.

5.1 POLYMER PREPARATION

All polymers and chemicals used for dosing were diluted from feed stock solution. For polymers supplied in powder form (see Table 4.3), the required mass of polymer was weighed using a mass balance. The powder was first wetted with 1 ml of 70 % ethanol and dissolved in 99 ml of luke-warm water under rapid mixing with a magnetic stirrer. For chemicals supplied in powder form, the required mass was weighed using a mass balance and dissolved with deionised water.

5.2 MBBR EFFLUENT SAMPLING

A “grab” sample of MBBR effluent was pumped from the MBBR reactors using a Watson Marlow 520R peristaltic pump (Cornwall, United Kingdom) running at 220 rpm into a large storage tank. MBBR effluent was pumped from mesh wire screens installed within the reactors to prevent withdrawal of biofilm carriers from the reactor.

The MBBR reactors from NFR are presented in Figure 5.1.

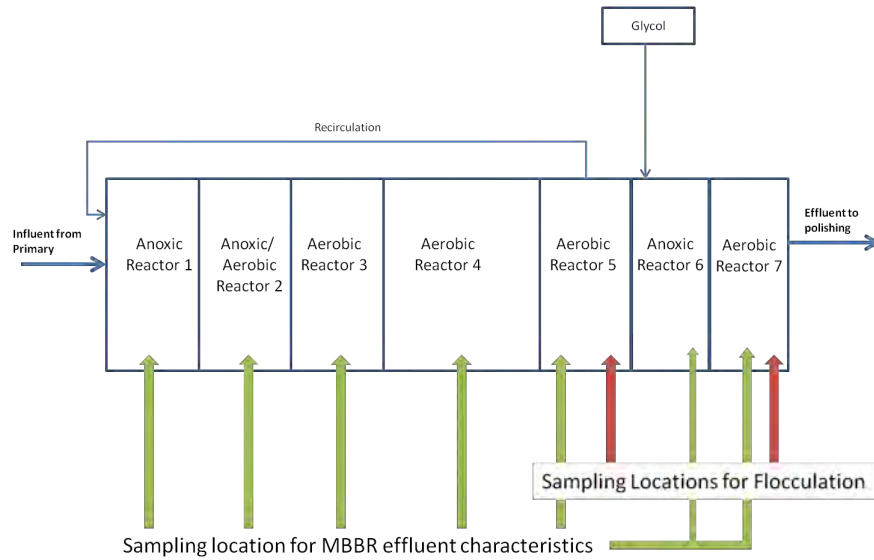

Figure 5.1: Schematic flow of Line 2 of NFR with sampling locations indicated (as shown using the red arrows). Biomass carriers were sampled from all the reactors (Reactor 1 through Reactor 7) during the period of this study.

5.3 SOLIDS ANALYSIS

5.3.1 Total Suspended Solids

SS were analysed according to the Standard Method 2540D. (AWWA, 1999)

5.3.2 Biomass on Carriers

The biomass on carriers were analysed according to the standard procedure of Aquateam AS. Fifteen (15) biofilm carriers were counted and dried at 105 °C overnight till constant weight. The dried carriers were cooled and their mass recorded. The dried carriers are subsequently soaked in full strength domestic sodium hypochlorate solution for 30 minutes and washed and scrubbed with warm water to remove all traces of biomass. The washed carriers are then dried at

105 °C overnight till constant weight. The mass of the carriers were recorded after cooling. The biomass on carriers are calculated

$$\text{Biomass per carrier (mg/carrier)} = \frac{M_{\text{carrier before washing}} - M_{\text{carrier after washing}}}{15} \quad (5.1)$$

5.3.3 Particles Screening Test using Salsnes Bench Scale Test Apparatus

In order to characterize particles in the MBBR effluent, the screening test apparatus and procedure as developed by [Rusten and Lundar \(2006\)](#) was used.

100 litres of MBBR effluent was collected using the method described in Section 5.2. The sample was manually stirred vigorously with a paddle prior to taken out of the tank for analysis or to be put through the test apparatus. A sample of unfiltered MBBR effluent was collected from the tank.

One litre of the sample MBBR effluent was filtered through the sieve cloth with the valve fully open and a sample was collected for analysis. More wastewater was added to test apparatus and the valve partially open such that the water level dropped 3 - 4 centimetres per second, allowing for a buildup of particles on the sieve cloth to form a filter mat.

Once a proper filter mat had formed on the sieve cloth, the valve was closed and the wastewater filled up to the 300 mm mark. The time taken for the water level to drop from the 300 mm to 200 mm mark with the valve fully opened was recorded.

5.3.4 Particle Size Distribution using Malvern Mastersizer 3000

PSD of the MBBR effluent was conducted with the following analysis method tabulated in Table 5.1. Samples were pumped from sample



Figure 5.2: Setup for PSD analysis with Malvern Mastersizer 3000 (sampling from flocculation jar test)

vials through the sampling cell at 60 ml/min using the peristaltic pump at the outlet port of the Malvern Mastersizer 3000. The standard operating procedure from Aquateam for running the software analysis (Appendix A.6) is used.

5.3.5 *Particle Size Distribution during flocculation using Malvern Mastersizer 3000*

PSD of the MBBR effluent was conducted with the setup as shown in Figure 5.3 with the analysis method tabulated in Table 5.1. Samples were pumped continuously from flocculation container through the sampling cell at 60 ml/min using the peristaltic pump at the outlet port of the Malvern Mastersizer 3000.

Table 5.1: Analysis procedure for biofilm solids PSD with Malvern Master-sizer 3000

Particle Type		Measurement obscuration settings	
Non-spherical particle mode	Yes	Obscuration low limit	0.10%
Is Fraunhofer type	No	Obscuration high limit	50.00%
Material Properties		Enable obscuration filtering	No
Refractive Index	1.330	Analysis settings	
Absorption Index	0.010	Analysis model	General Purpose
Particle Density	1.00 g/cm ³	Single result mode	No
Different optical properties in blue light	No	Number of killed inner detectors	0
Dispersant Properties		Blue light detectors killed	No
Disperant Name	Water	Scattering model	Mie
Refractive Index	1.330		
Measurement duration			
Background (Red)	5.00 seconds		
Sample (Red)	5.00 seconds		
Background (Blue)	5.00 seconds		
Sample (Blue)	5.00 seconds		



Figure 5.3: Setup for PSD analysis with Malvern Mastersizer 3000 during pilot scale flocculation

5.4 CHEMICAL OXYGEN DEMAND MEASUREMENT

For analysis of unfiltered or total COD of the liquid samples, all samples were homogenized for 1 minute using a T18 ULTRA-TURRAX® (IKA, Germany) at 16000 rpm prior to analysis. The analysis of COD was conducted according to the procedure provided by Dr. Lange cuvette test kits LCK 414 and LCK 616 (Appendices A.2 and A.3).

For analysis of filtered COD of the liquid samples, the samples were filtered through a 1.2 μm Whatman GF/C glass microfibre filter. The filtrate was collected and analysis of COD was conducted according to the procedure provided by Dr. Lange cuvette test kits LCK 414.

5.5 PHOSPHATE MEASUREMENT

For analysis of orthophosphate in the liquid samples, samples were filtered through a 1.2 μm Whatman GF/C glass microfibre filter. The

filtrate was collected and analysis of phosphate was conducted according to the procedure provided by Dr. Lange cuvette test kits LCK 349 (Appendices A.4).

5.6 INITIAL FLOCCULANT SCREENING JAR TEST

80 litres of MBBR effluent was collected from Reactor 5 and Reactor 7 using the method described in Section 5.2. The sample was manually stirred vigorously with a paddle prior to taken out of the tank for analysis or to be put through the jar testing. A sample of unfiltered MBBR effluent was collected from the tank for solids analysis.

One litre of MBBR effluent was measured using a graduated cylinder and placed in the jar test beakers. The sample was dosed with a flocculant to achieve a final dosed concentration of 10 mg/l and the dosed MBBR effluent was mixed rapidly for 10 seconds at 350 rpm, followed by 10 minutes of slow mixing at 40 rpm and 10 minutes of settling. For the initial screening, turbidity of the supernatant and depth of settled flocs were recorded and used as the basis for further testing.

5.7 FLOCCULANT DOSING JAR TEST

100 litres of MBBR effluent was collected from Reactor 5 using the method described in Section 5.2. The sample was manually stirred vigorously with a paddle prior to taken out of the tank for analysis or to be put through the jar testing. A sample of unfiltered MBBR effluent was collected from the tank for solids analysis.

One litre of MBBR effluent was measured using a graduated cylinder and placed in the jar test beakers. The flocculants and the final concentration of the flocculants used for the jar test are tabulated in Table 5.2. Upon the addition of the flocculant chemical, the sample

Table 5.2: Flocculants and final dosing concentrations used for jar test

Flocculants	Flocculant Concentration in Jar Test
Superfloc C-491K	1, 2, 5, 10 mg/l
Superfloc C-496	1, 2, 5, 10 mg/l
Zetag 9046 FS	1, 2, 5, 10 mg/l
Zetag 9048 FS	1, 2, 5, 10 mg/l
PAX XL-60	2, 4, 8 mg-Al/l
Ferric Chloride (FeCl ₃)	2, 4, 8 mg-Fe/l

was subjected to 10 seconds of rapid mixing at 350 rpm, followed by 10 minutes of slow mixing at 40 rpm and 10 minutes of settling.

5.8 MIXING OPTIMISATION WITH JAR TEST

100 litres of MBBR effluent was collected from Reactor 5 using the method described in Section 5.2. The sample was manually stirred vigorously with a paddle prior to taken out of the tank for analysis or to be put through the jar testing. A sample of unfiltered MBBR effluent was collected from the tank for solids analysis.

One litre of MBBR effluent was measured using a graduated cylinder and placed in the jar test beakers. Two flocculants were studied with the jar test: 2 mg/l of Superfloc C-496 (polymer) and 8 mg/l of PAX XL-60 (chemical). Upon the addition of the flocculant chemical, the sample was subjected to the mixing protocol as presented in Figure 5.4.

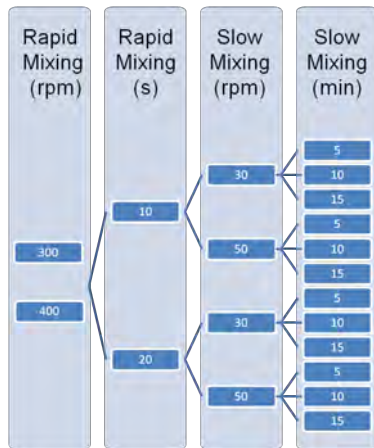

Figure 5.4: Protocol for mixing optimisation with jar test

5.9 PILOT SCALE FLOCCULATION

5.9.1 Floc size changes during pilot scale flocculation

100 litres of MBBR effluent was collected from Reactor 5 using the method described in Section 5.2. The sample was manually stirred vigorously with a paddle prior to taken out of the tank for analysis or to be put through the jar testing. A sample of unfiltered MBBR effluent was collected from the tank for solids analysis.

20 litres of MBBR effluent was measured using a graduated cylinder and placed in a 25 litres HDPE container. Two flocculants were studied at the pilot scale: 2 mg/l of Superfloc C-496 (polymer) and 8 mg/l of PAX XL-60 (chemical). Upon the addition of the flocculant chemical, the sample was subjected the mixing protocol as presented in Table 5.4. Floc size analysis of the flocculation process was studied continuously online with the Malvern Mastersizer 3000 by pumping the flocculating sample from the container to the instrument.

Table 5.3: Mixing protocol and approximated G-values for pilot-scale flocculation

	Orange Stirrer	Red Stirrer	Silver Stirrer
Rapid mixing (s)	20	20	20
Rapid mixing (rpm)	~300	~300	~300
Power (W)	10.56	10.67	10.89
G (s^{-1})	~300	~300	~300
Slow mixing (min)	15	15	15
Slow mixing (rpm)	~25	~25	~25
Power (W)	0.704	0.704	0.64
G (s^{-1})	60	65	60

5.9.2 Pilot Scale Flocculation for Superfloc C-496

100 litres of MBBR effluent was collected from Reactor 5 using the method described in Section 5.2. The sample was manually stirred vigorously with a paddle prior to taken out of the tank for analysis or to be put through the jar testing. A sample of unfiltered MBBR effluent was collected from the tank for solids analysis.

20 litres of MBBR effluent was measured using a graduated cylinder and placed in a 25 litres HDPE container. Superfloc C-496 (polymer) at a final dosed concentration of 2 mg/l was studied at pilot scale. Upon the addition of the flocculant chemical, the sample was subjected the mixing protocol as presented in Table 5.4.

Table 5.4: Mixing protocol and approximated G-values for pilot-scale flocculation with Superfloc C-496

	Orange Stirrer	Red Stirrer	Silver Stirrer
Rapid mixing (s)	20	20	20
Rapid mixing (rpm)	~300	~300	~300
Power (W)	10.56	10.67	10.89
G (s ⁻¹)	~300	~300	~300
Slow mixing (min)	5	5	5
Slow mixing (rpm)	~25	~25	~25
Power (W)	0.704	0.704	0.64
G (s ⁻¹)	60	65	60

5.9.3 Pilot Scale Flocculation for PAX XL-60

100 litres of MBBR effluent was collected from Reactor 5 using the method described in Section 5.2. The sample was manually stirred vigorously with a paddle prior to taken out of the tank for analysis or to be put through the jar testing. A sample of unfiltered MBBR effluent was collected from the tank for solids analysis.

20 litres of MBBR effluent was measured using a graduated cylinder and placed in a 25 litres HDPE container. PAX XL-60 (chemical) at a final dosed concentration of 8 mg/l was studied at pilot scale. Upon the addition of PAX XL-60, the sample was subjected the mixing protocol as presented in Table 5.5.

Table 5.5: Mixing protocol and approximated G-values for pilot-scale flocculation with PAX XL-60

	Orange Stirrer	Red Stirrer	Silver Stirrer
Rapid mixing (s)	20	20	20
Rapid mixing (rpm)	~300	~300	~300
Power (W)	10.56	10.67	10.89
G (s^{-1})	~300	~300	~300
Slow mixing (min)	10	10	10
Slow mixing (rpm)	~25	~25	~25
Power (W)	0.704	0.704	0.64
G (s^{-1})	60	65	60

Part IV

RESULTS AND DISCUSSIONS

RESULTS AND DISCUSSIONS

6.1 WASTEWATER AND MBBR EFFLUENT CHARACTERISTICS

NFR is designed to treat primarily municipal wastewater from 3 municipalities in the south of Oslo. The sewer network transporting sewage to NFR is also connected with the stormwater management network in the municipalities. The characteristics of the wastewater to be treated by the NFR MBBR are presented in the following subsection.

6.1.1 *Flow and Load to Nordre Follo Renseanlegg*

The wastewater flow to NFR during the experimental period (September 2011 to April 2012) is presented in Figure 6.1. The flow to NFR varied according to the prevailing weather and climatic conditions; the influent flows which are higher than the nominal flow (10 000 m³/d) (Rusten and Paulsrud, 2008) were due to high precipitation in autumn and due to snow melt water and precipitation in winter and spring. The influent to the MBBR was designed to be balanced between the two lines of reactors but due to maintenance of Line 1 in November-December 2011 and maintenance of Line 2 in March 2012, the respective flows were diverted (partially in 2011 and fully in 2012) to the other operating line. The biomass on carriers for the seven reactors during the benchscale filter sampling period is presented in Figure 6.3.

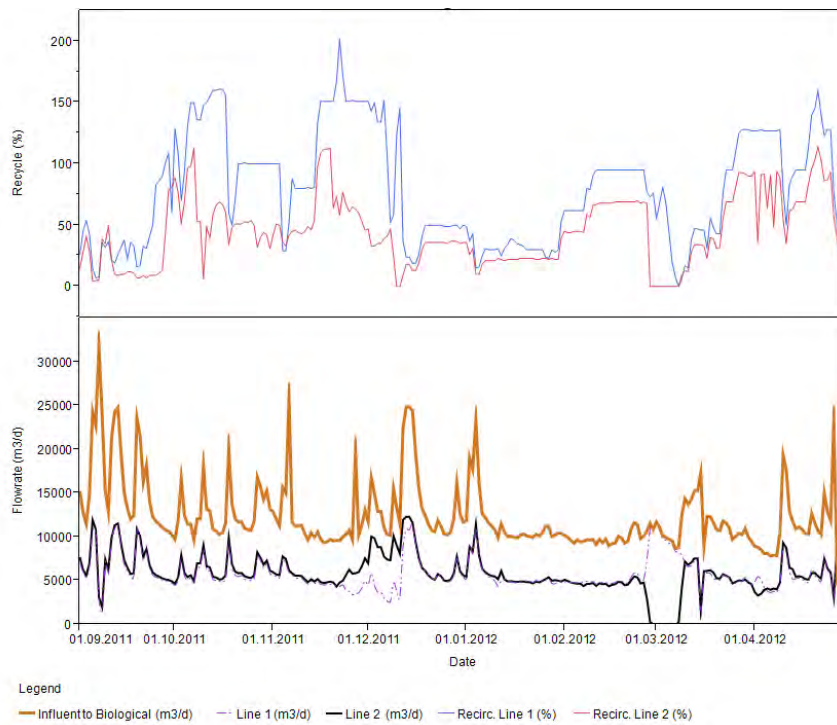

Figure 6.1: Wastewater flow to NFR MBBR during the experimental period

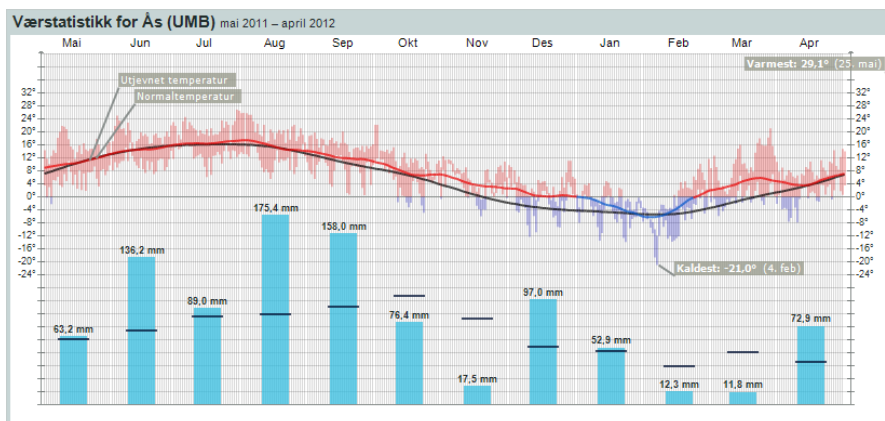

Figure 6.2: Weather conditions at Ås municipality (source: www.yr.no)

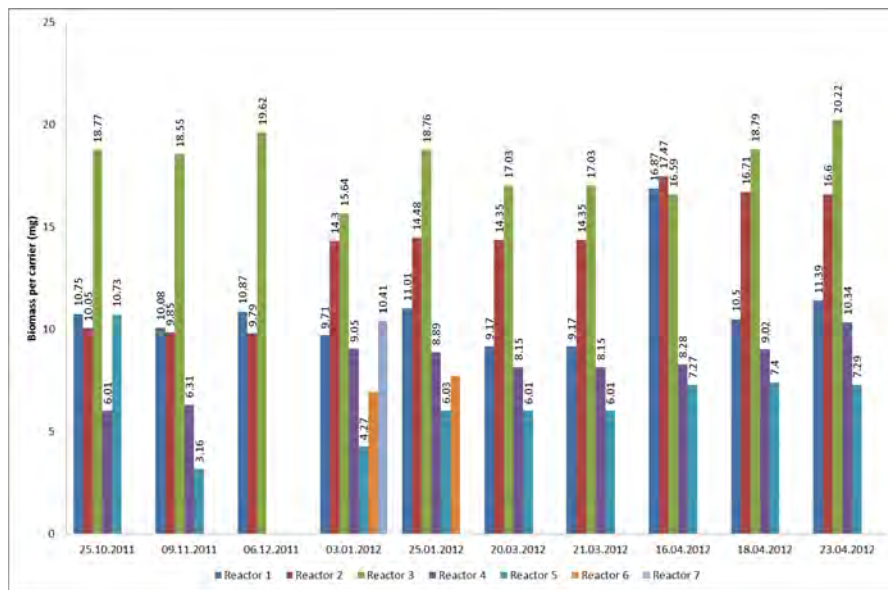

Figure 6.3: Variation of biomass on carriers for various NFR MBBR reactors

6.1.2 Particle Size Distribution for Nordre Follo MBBR Reactors

Figure 6.4 shows the results of particle size measurements using the Malvern Mastersizer 3000 on the effluents of all MBBR reactors in NFR. The results show a shift in maximum value of the particle size distribution from the first reactor (R1) to the fifth reactor (R5). The spread of the particles are distributed over a wide range from less than $1 \mu\text{m}$ to larger than $500 \mu\text{m}$. The peak volume distribution in the MBBR effluents are around the $100 \mu\text{m}$ range. The organic loading of the reactors decreases from Reactor 1 to Reactor 5 before increasing in Reactor 6 due to external carbon source added for further denitrification. The shift in PSD from smaller particle volume to larger particle volume with increasing hydraulic retention time (HRT) (decreasing organic loading) obtained from this study is in agreement with studies conducted by Åhl et al. (2006), Leiknes and Ødegaard (2007) and Melin et al. (2005).

Figure 6.5 shows the results of SS size distribution obtained from the benchscale SF test apparatus. The results shows a shift in SS size distribution towards a higher percentage of larger sizes from Reactor

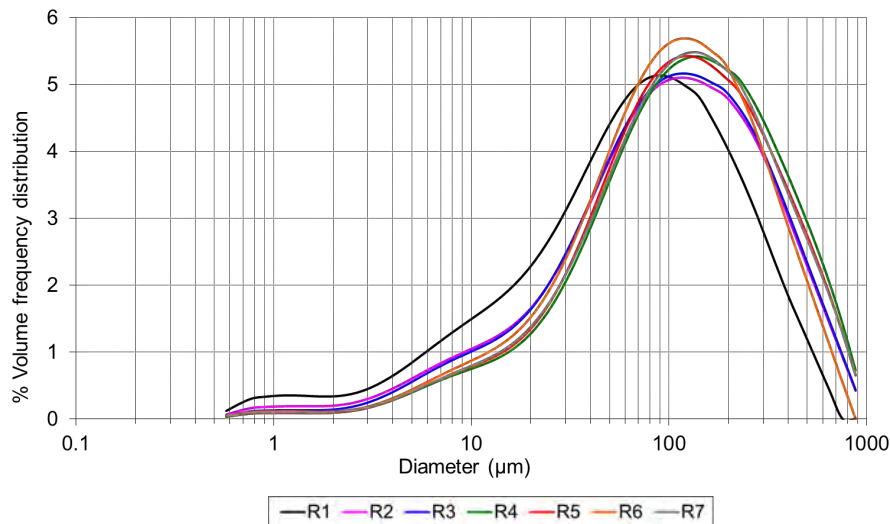

Figure 6.4: Particle size distribution in effluents of 7 MBBR reactors in Nordre Follo WWTP

1 to Reactor 5 (i.e. with decreasing organic loading). The results obtained using the benchscale SF test apparatus are also in agreement with the results obtained with the Malvern Mastersizer.

The size characteristics of particles and SS in MBBR effluents obtained from both the Malvern and benchscale SF test are important especially for biomass separation by physical barriers (such as sieving and screening). This approach of designing microscreens and predicting separation efficiency of microscreens has been recommended and with at least one successful implementation with microscreens (Ljunggren, 2006). The size characteristics obtained with the benchscale SF test is a key criterion used for predicting separation efficiencies and implementation of full scale SF rotating belt sieves installations (Rusten, 2004; Rusten and Lundar, 2006).

6.2 INITIAL FLOCCULANT SCREENING USING JAR TEST

In order to identify the type of flocculants suitable for flocculating biofilm solids from MBBR effluents, a total of 16 chemicals and poly-

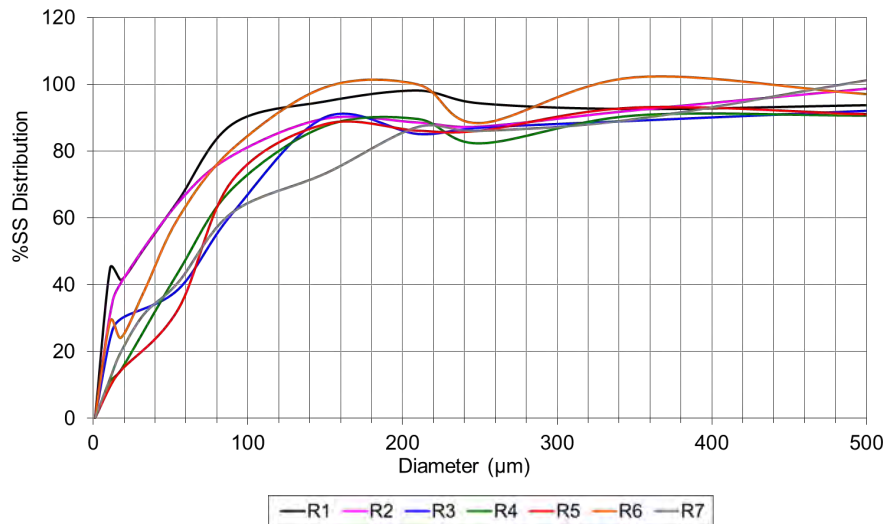

Figure 6.5: Suspended solids size distribution from Salsnes Filters Test Apparatus

mers were screened with the Kemira jar test apparatus. The MBBR effluents from NFR reactors 5 and 7 were used for testing. The turbidity of the settled flocculated reactor effluent was used as the selection criteria. The results of the tests are presented in Figures 6.6 and 6.7.

The chemicals and polymers were dosed at a final 10 mg/l for both reactor effluents. The high concentration of flocculants was used to ensure that sufficient flocculants are present for removal of SS even at higher than nominal effluent SS concentration. For NFR reactor 5 effluent, all flocculants resulted in more than 55% turbidity removal. Magnafloc 919 and Superfloc C-577 had the worst turbidity removal among the studied flocculants. With only settling of the unflocculated reactor effluent (labelled as blank in the figures), 84% of the initial turbidity was removed. Of the 3 anionic polymer-based flocculant, only Magnafloc 155 had better turbidity removal compared to settled unflocculated effluent. Both metal-based chemicals (PAX XL-60 - polyaluminum hydroxide and ferric chloride) had marginal improved turbidity removal (7% and 9% respectively). All cationic polymer-based flocculants had improved turbidity removal (1% to 10%) with the exception of Superfloc C-577 which had deteriorated turbidity removal.

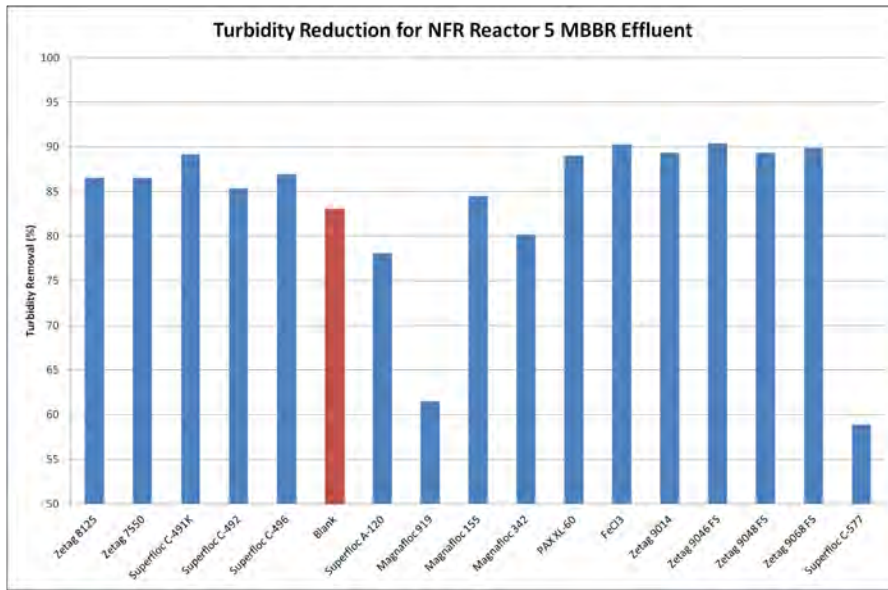

Figure 6.6: Turbidity removal for Reactor 5

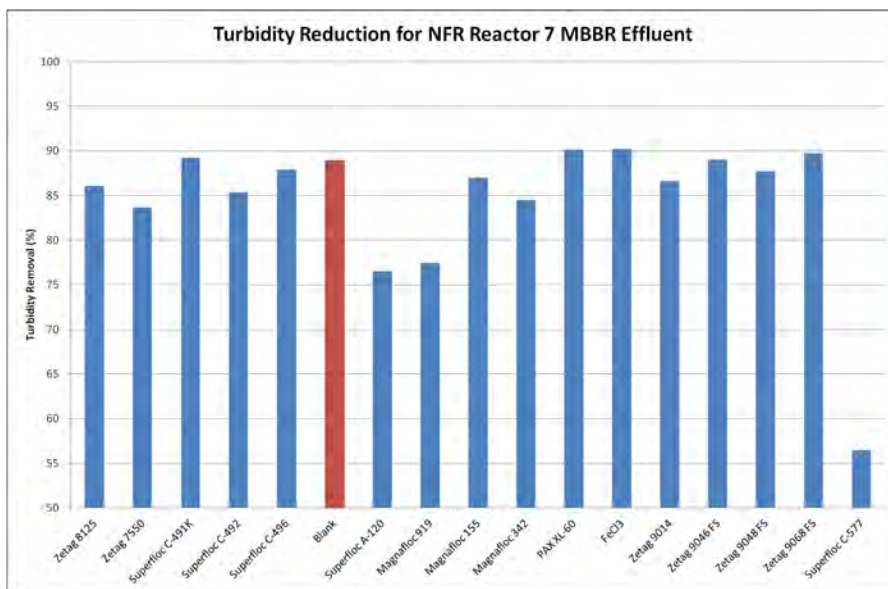

Figure 6.7: Turbidity removal for Reactor 7

For NFR reactor 7 effluent, all flocculants resulted in more than 55% turbidity removal with Superfloc C-577 having the worst turbidity removal. With only settling of the unflocculated reactor effluent (labelled blank in the figures), 88% of the initial turbidity was removed. Of the 3 anionic polymer-based flocculant, all had deteriorated turbidity removal compared to settled unflocculated effluent. Both metal-based chemicals had marginal improved turbidity removal (2%). All cationic polymer-based flocculants had marginal improvement or deteriorated turbidity removal (-5% to 1%) with the exception of Superfloc C-577 which had deteriorated turbidity removal of 37%.

Only six coagulants could be tested in the second set of more comprehensive jar tests. The flocculants selected for further optimisation and screening were 4 cationic polymers (Superfloc C-491K and Superfloc C-496 from Kemira, and Zetag 9046FS and Zetag 9068FS from BASF) and 2 metal-based chemicals (PAX XL and ferric chloride from Kemira). The metal-based chemicals were selected for their ability to remove phosphorus from the MBBR effluent in addition to improved turbidity removal. In addition, a combination of metal-based chemical and polymer-based flocculant was tested. The doses selected for further studies are presented in Table 6.1.

6.3 FLOCCULANT DOSAGE OPTIMISATION IN JAR TEST

The six flocculants (Table 6.1) selected for further studies were tested to evaluate the ability of these flocculants to improve the removal of biofilm solids from the effluent of NFR MBBR. The jar tests were performed with reactor 5 effluent from NFR MBBR Line 2. As evident from Table 6.2, the characteristics of the MBBR effluent varied from day to day due to changes in flow rates, recycle ratios and MBBR influent characteristics, therefore, all removal efficiencies are expressed in terms of percentage to normalise the effects of varying initial starting

Table 6.1: Flocculants and doses selected from screening study for further studies

Flocculants	Dosage for further studies (mg/l)			
Superfloc C-491K	1	2	5	10
Superfloc C-496	1	2	5	10
Zetag 9046 FS	1	2	5	10
Zetag 9048 FS	1	2	5	10
PAX XL-60 (as Al)	2	4	8	
FeCl ₃ (as Fe)	2	4	8	
PAX XL-60 (as Al) + Superfloc C-496	5 + 1	7 + 1	9 + 1	
PAX XL-60 (as Al) + Superfloc C-496	5 + 2	7 + 2	9 + 1	

SS concentrations. The SS removal efficiency of the flocculants were recorded and compared against the unflocculated MBBR effluent and the results of the analyses are presented in Figure 6.8.

The unflocculated MBBR effluent after undergoing the same mixing protocol as the flocculated MBBR effluent had 86% of the initial SS removed. The results of the jar test flocculation indicated use of polymer-based flocculants had only marginal effects on SS removal. Both cationic flocculants (Superfloc C-491K and Superfloc C-496) from Kemira had deteriorated SS removal efficiency (up to 6%) at higher dosages compared to the unflocculated and the optimal dosing is at 2 mg per litre of MBBR effluent. Both cationic flocculants from BASF had improved SS removal at higher dosed concentration with the maximum removal occurring at 10 mg/l. The polyaluminium hydroxide based flocculant from Kemira had the best SS removal (90%) compared to the rest of the flocculant with best removal efficiency at 8 mg of aluminium per litre of MBBR effluent. Of the 3 doses of ferric

Table 6.2: NFR Line 2 Reactor 5 MBBR Effluent SS concentration variation

Date	SS (mg/l)	Date	SS (mg/l)
25 Oct 2011	88	20 Mar 2011	187
09 Nov 2011	96	21 Mar 2011	215
13 Feb 2011	206	16 Apr 2011	171
14 Feb 2011	207	18 Apr 2011	171
16 Feb 2011	189	23 Apr 2011	67

chloride tested, 8 mg of iron(III) per litre of MBBR effluent resulted in the worst SS removal efficiency (74%) among all doses studied.

From the results of the study, 2 flocculants were selected for further study of mixing intensity and time: 2 mg/l of Superfloc C-496 (polymer) and 8 mg/l of PAX XL-60 (chemical). The former was selected for the performance amongst the lower polymer dosing concentration as well as the handling of the source material. The latter was selected for having the best performance among the metal-based flocculants and the ease of handling the chemical. In Norway, operators of wastewater treatment plants prefer the use of less non-corrosive chemicals compared to ferric chloride.

6.4 FLOCCULATION OPTIMISATION IN JAR TEST

A series of studies were conducted with flocculants selected from the previous study of optimal dosing. The studies examine the effects of (1) initial mixing intensity, (2) initial mixing time, (3) flocculation intensity and (4) flocculation timing on the removal efficiency of SS. Additionally, the flocculated MBBR effluents are passed through SF sieve cloths of 210 μm and 90 μm to investigate the effects of sieving after flocculation on SS removal. SS removal is calculated as

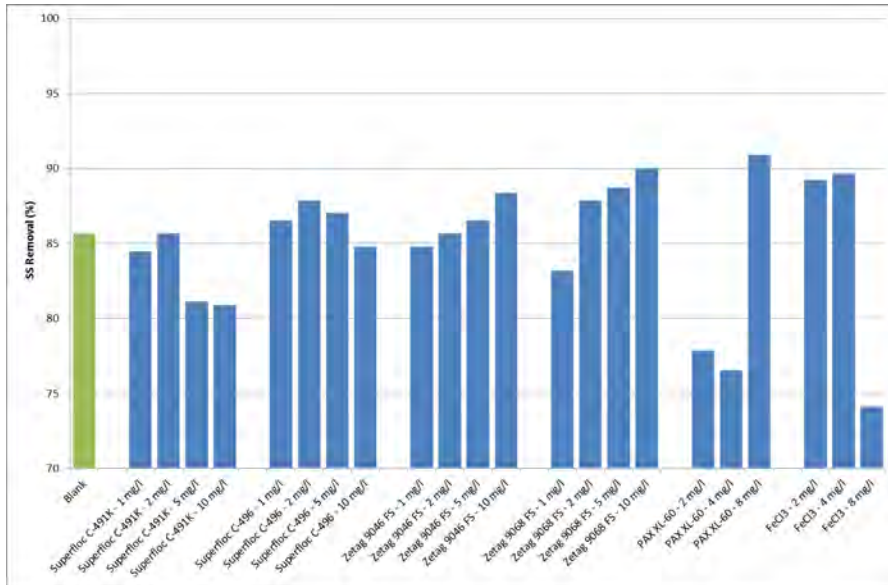

(a) Single flocculants used for dosing

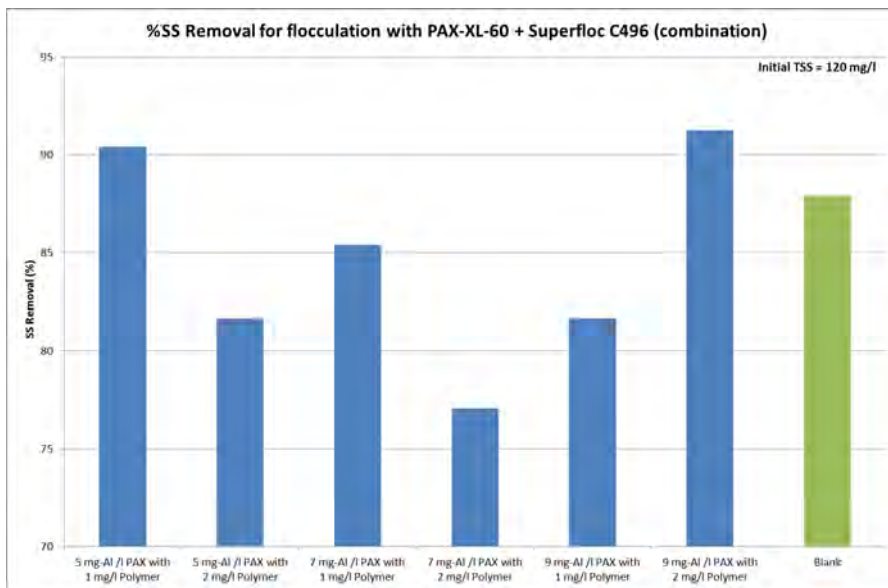

(b) Combination of chemical and flocculant

Figure 6.8: TSS removal for NFR Line Reactor 5 effluent using varying doses of flocculants: (a) Flocculation done with only one flocculant, and (b) flocculation with a combination of flocculants

$$\text{SS Removal (\%)} = \frac{\text{SS}_{\text{After flocculation}} - \text{SS}_{\text{Before flocculation}}}{\text{SS}_{\text{Before flocculation}}} \times 100\% \quad (6.1)$$

The results of the studies are presented in Figures 6.9a and 6.9b for the polymer-based flocculant and aluminium-based flocculant over a range of mixing times and intensities and flocculation times and intensities.

6.4.1 *Effects of Mixing Intensities and Mixing Times*

As evident from Figure 6.9, the rapid mixing intensities and timings have a marked influence on the overall SS removal. Higher intensity of initial rapid mixing (400 rpm) resulted in significantly lower SS removal ($P = 0.1$) for both flocculants compared to lower intensity rapid mixing of 300 rpm. Relative to flocculation with PAX XL-60, the removal efficiency of SS is significantly better ($P = 0.1$) with Superfloc C-496 at 300 rpm with or without sieving.

During rapid mixing, there is no significant difference ($P = 0.1$) between the SS removal efficiencies for polymers except when the flocculated MBBR effluent was sieved with 90 μm sieve cloth. The best SS removal efficiency was achieved when rapid mixing was carried out at 20 seconds instead of 10 seconds.

6.4.2 *Effects of Flocculation Intensities and Flocculation Times*

Analyses of the results revealed insignificant difference ($P = 0.1$) between the lower intensity flocculation and the higher intensity flocculation for both flocculants especially for the unsieved flocculated MBBR effluent. Marginal improvement in actual SS removal can be observed with higher intensity flocculation with the best SS removal when used with a 90 μm sieve. The increased SS removal using a 90 μm over 210 μm indicates flocs formed during flocculation with

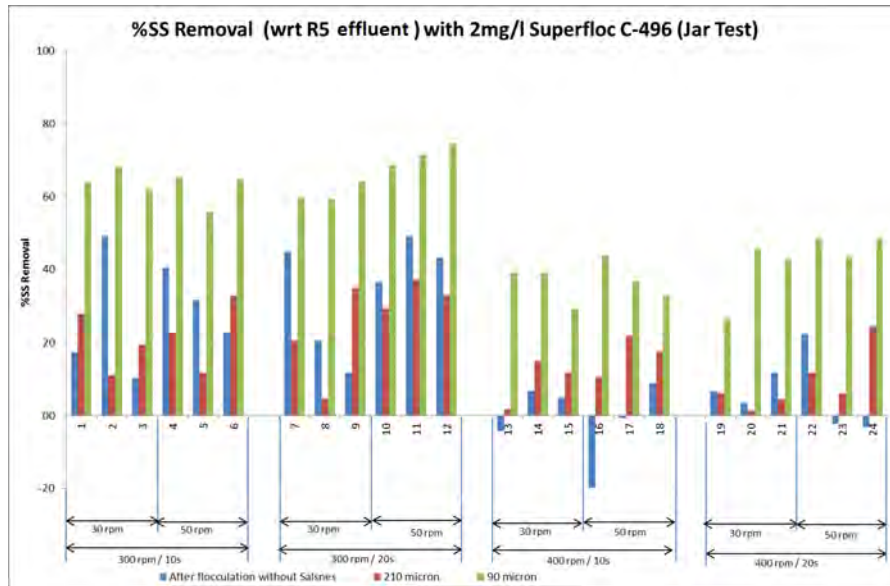

(a) Flocculation with 2 mg/l Superfloc C-496

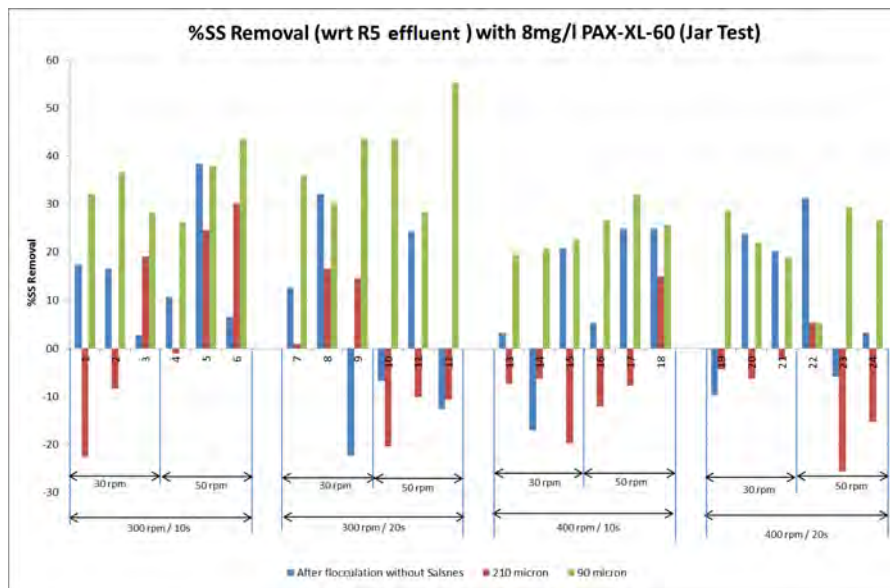

(b) Flocculation with 8 mg-Al/l PAX XL-60

Figure 6.9: TSS removal with varying flocculation mixing settings

are smaller than 210 μm . As observed from Figure 6.9, there is a difference in SS removal with 210 μm compared to unsieved flocculated MBBR effluent. The difference in performance may be attributed in part to the breakup of floc during the sieving process and also in part to experimental errors arising from the splitting of flocculated effluent for sieving.

There was no significant difference ($P = 0.1$) between the flocculation times tested with the unsieved flocculated MBBR effluent as well as 90 μm sieved flocculated MBBR effluent. The only significant difference ($P = 0.1$) lies between the flocculation time of 5 minutes and 15 minutes when sieving with 210 μm ; SS removal efficiency is improved with 15 minutes of flocculation time.

The negative removal of SS in the study of aluminium-based flocculant may be attributed to the generation of aluminium hydroxide complexes during the flocculation process leading to an increase of SS in the flocculated wastewater. The negative SS removal with polymer-based flocculant is likely due to experimental error arising from incomplete mixing and resuspension of the settled flocs prior to splitting the samples for SS analysis.

As seen from Figure 6.9, the best SS removal is achieved when with 15 minutes of flocculation at 50 rpm of flocculation intensity for both polymer-based and aluminium-based flocculant: 75% and 55% respectively.

6.4.3 Combined Effects of Mixing and Flocculation

The formation of flocs and the efficiency of SS removal is a function of both mixing and flocculation as evident from Figure 6.9. The mixing and flocculation program selected for the pilot scale flocculation studies was 20 seconds of rapid mixing at 300 rpm followed by 15 minutes of flocculation at 50 rpm. The corresponding G-values for the mixing

and flocculation are ca. 330 s^{-1} and ca. 30 s^{-1} respectively (Søraker, 2012).

6.5 PILOT SCALE FLOCCULATION

6.5.1 *Stirrer Types and approximated G-values*

Pilot scale studies of the flocculation settings were conducted with 3 different mechanical stirrers as described in Section 4.11. The objective of the studies was to study the effects on different stirrers on the flocculation process and the resulting SS removal. The approximate G-values of the different stirrers were studied using the power consumption calibrated against the rotation of the stirrers. The G-values and power consumption of the pilot scale setup used for all pilot scale flocculation are presented in Table 6.3.

	Orange Stirrer	Red Stirrer	Silver Stirrer
Rapid Mixing (s)	20	20	20
Rapid Mixing (rpm)	~300	~300	~300
Power (W)	10.56	10.67	10.89
G (s^{-1})	~300	~300	~300
Flocculation Time (s)	15	15	15
Flocculation Mixing (rpm)	~25	~25	~25
Power (W)	0.704	0.704	0.64
G (s^{-1})	60	65	60

Table 6.3: Power Consumption of pilot scale flocculation

The intensity of the pilot scale flocculation was estimated to be at least twice of the G-values ($\sim 60 \text{ s}^{-1}$) determined from the jar test. The use of doubled G-values was intentional and is due to the limitation of the mechanical motor; if the supplied power was below than the defined supply, the motor would not run resulting in no mixing.

6.5.2 Flocculation Timing

A series of experiments were carried out at the pilot scale to study effect of flocculation times on the floc sizes and to determine the optimal duration for flocculation. Figures 6.10 and 6.12 show the variation of the floc sizes during flocculation with Superfloc C-496 and PAX XL-60 respectively. The analyses of the floc sizes were done with a Malvern Mastersizer 3000 and only the volumetric equivalent diameter from the DV50 distribution was considered. The figures showed the difference between flocculation with polymer-based and with aluminium-based flocculants: flocculation with polymer required less time (3 minutes) to achieve largest floc size compared to 10 minutes with PAX.

As seen in Figure 6.10, formation of large flocs occurred primarily in the first minutes of flocculation mixing and before reaching a “steady” size after 6 minutes. The decline in the floc size after the “steady” state was not due to sheer forces disrupting the flocs; it resulted from the settling of the flocs to the bottom of the tank (Figure 6.11). The G-values were not sufficient to keep the large flocs in suspension for analysis.

As seen in Figure 6.12, formation of large flocs occurred mainly after 6 minutes of flocculation mixing and before reaching a “steady” size after 9 minutes. The size variations show a gradual increment in floc size and is consistent with site observation of the flocculation process. The decline in the floc size after the “steady” state was not

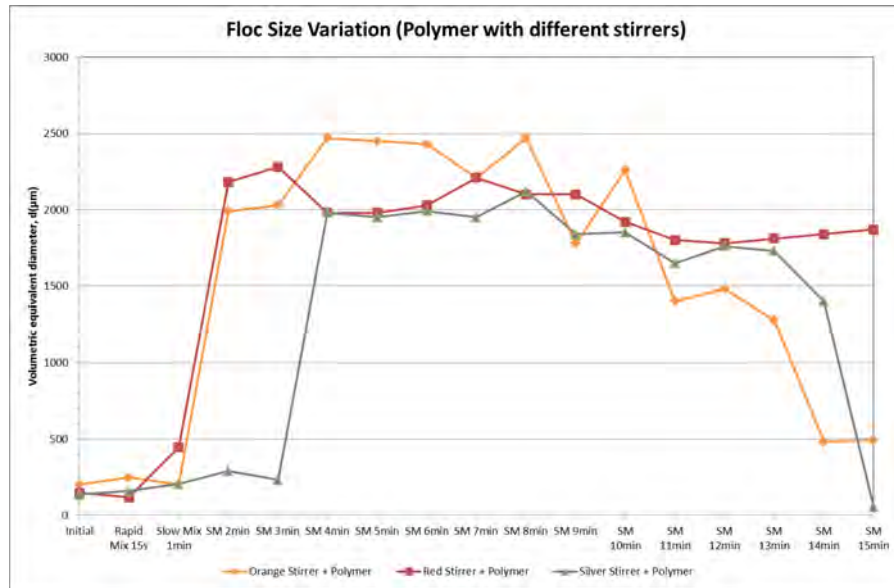

Figure 6.10: Floc size variation during flocculation with polymer (Superfloc C-496K). The floc size refers to volumetric equivalent diameter at DV50 as analysed by Malvern Mastersizer 3000. SM refers to flocculation mixing.



Figure 6.11: Settling of flocs during flocculation with Superfloc C-496 and the silver stirrer. The settled flocs are visible as a ring around the stirrer and of a darker color compared to the bulk liquid.

as prominent as the case with Superfloc C-496 with the decline observed mainly with the silver stirrer after 9 minutes (Figure 6.13). It may be possible that the “steady state” had not been achieved and flocculation time may need to be increased to observe the settling of flocs.

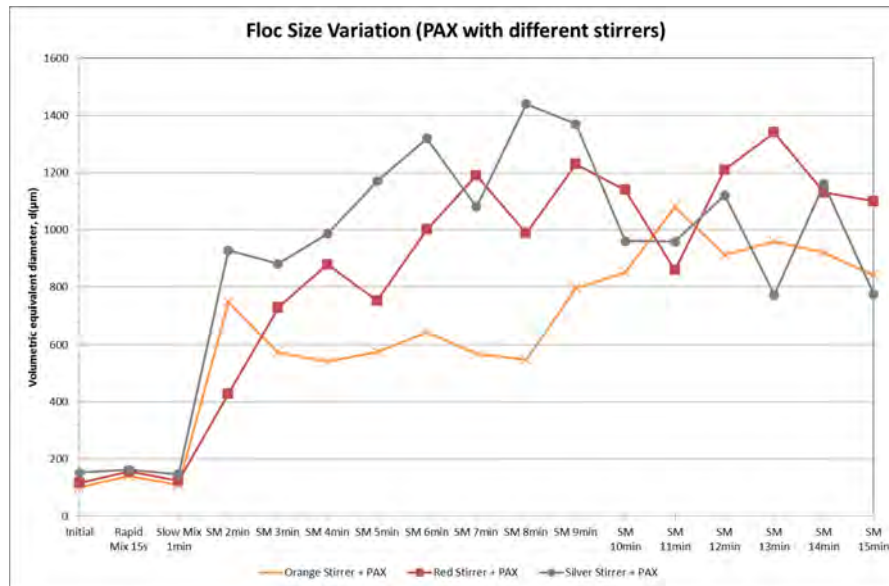

Figure 6.12: Floc size variation during flocculation with polymer (PAX XL-60). The floc size refers to volumetric equivalent diameter at DV50 as analysed by Malvern Mastersizer 3000. SM refers to flocculation mixing.

6.5.3 Biofilm solids and Flocs Images

Figure 6.14 shows the typical biofilm solids found in the effluent of NFR reactor 5. The variation in sizes of the biofilm solids can be seen clearly and gives support to the particle size distribution presented in Section 6.1.2.

Figures 6.15 and 6.16 show the typical flocs formed during pilot scale flocculation with different mixers and flocculants. From the results, it may be seen that the floc size and floc shape and structure are influenced by the type of stirrers and the flocculants. As can be



Figure 6.13: Settling of flocs during flocculation with PAX XL-60 and silver stirrer. The settled flocs are visible as a ring around the stirrer and of a darker color compared to the bulk liquid.

seen from the figures, the flocs are non-spherical in nature with presence of void spaces within the flocs and also the interactions between flocs. The non-spherical nature and the compressibility of the flocs will have a direct influence on the design of SF sieve cloths and the light opening of sieve cloths. For example, when utilising a 250 μm sieve for a rod-shaped floc from red-stirrer PAX XL-60 flocculated effluent, the floc may pass through the opening if the floc meets the

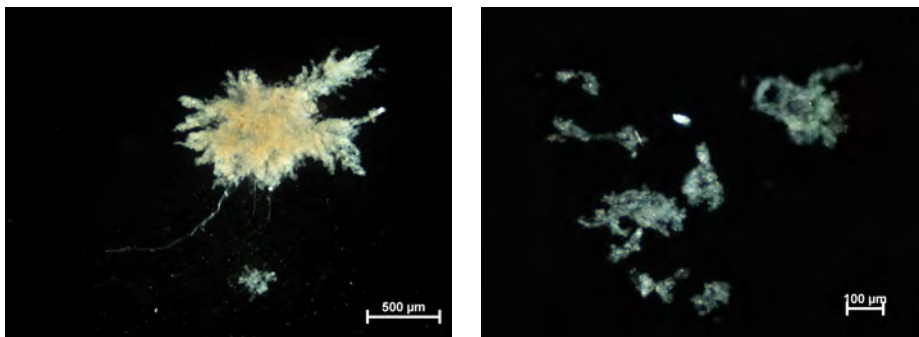

Figure 6.14: Biofilm solids in NFR Reactor 5 MBBR Effluent

opening width-wise but it may also be retained when meeting the sieve opening length-wise.

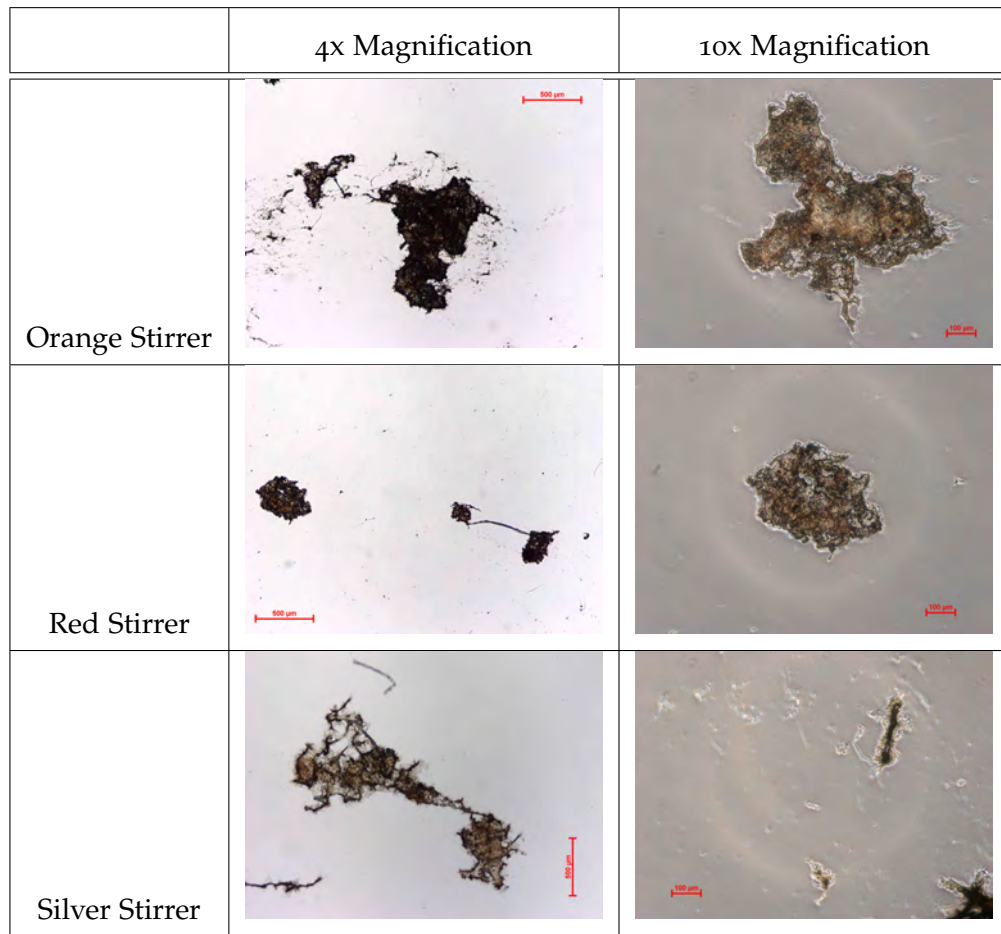

Figure 6.15: Floccs formed from flocculation of NFR reactor 5 effluent with Superfloc C-496

6.6 BENCHSCALE SALSNES FILTER TEST APPARATUS

The benchscale Salsnes Filter test apparatus was invented for the objectives of characterizing wastewaters with respect to suspended solids and also to investigate the efficiency of solids removal with different sieve mesh sizes. The data obtained from the benchscale test apparatus are used to estimate the hydraulic capacities and filtration rates and these are used in turn for the design and operation of full scale Salsnes Filter machines for wastewater treatment. The results

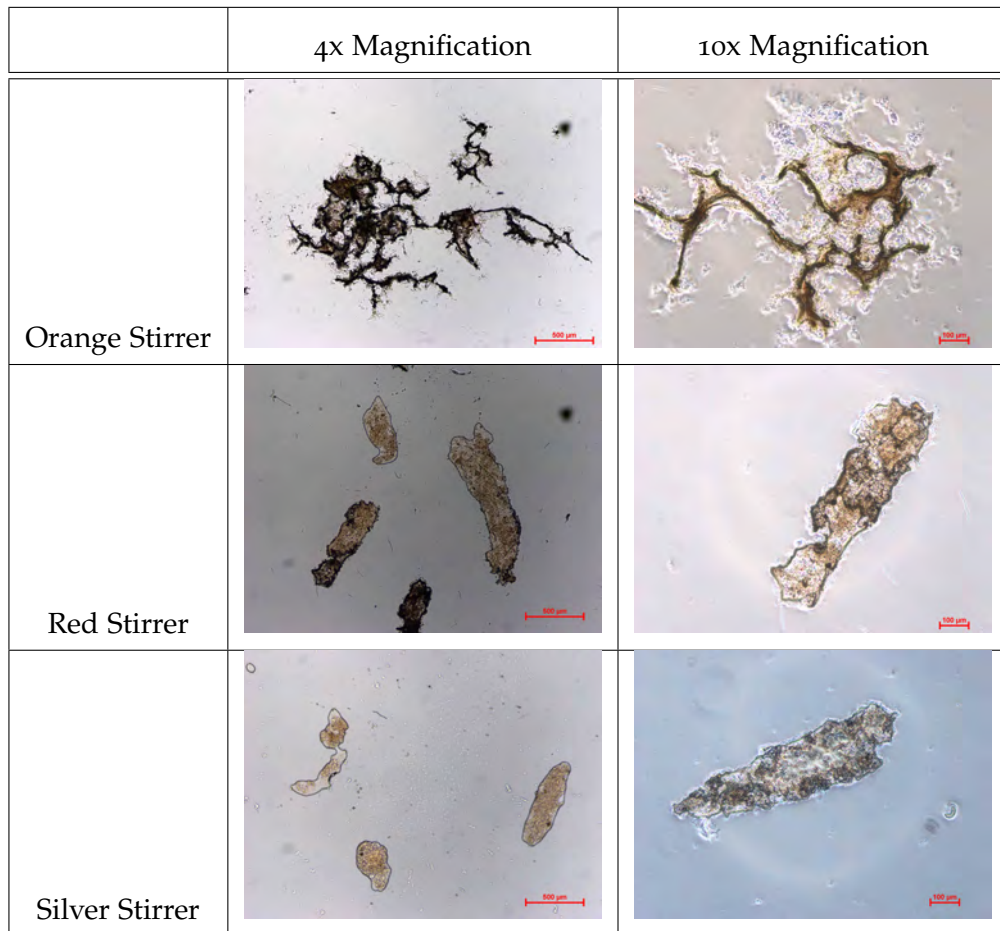

Figure 6.16: Flocs formed from flocculation of NFR reactor 5 effluent with PAX XL-60

presented in the following sub-sections represent the key parameters for the design of full scale Salsnes Filter machines (Rusten, 2004).

6.6.1 Application to NFR MBBR Reactor Effluent

6.6.1.1 Suspended Solids and Chemical Oxygen Demand Removal

The results of the SS and COD removal with SF sieves for effluents from all seven reactors in NFR are presented in Figures 6.17 and 6.18 respectively. The results show an improvement in SS removal with decreasing light opening on the fine mesh sieves. In addition, the SS removal performance increases with increasing wastewater hydraulic

retention time in the reactors when there is no added carbon source, i.e. *SS* removal increases from reactor 1 to reactor 5. When external *COD* (in the form of glycol) is added to the reactors, there was lowered *SS* removal.

Where external *COD* is added, the trend of *SS* removal is similar to the case where external *COD* is not added: the removal of *SS* is increased with hydraulic retention time, i.e. when comparing reactor 6 and reactor 7, *SS* removal was better in reactor 7. The outlier point at 210 μm for reactor 5 is likely due to sampling error during the studies and was not considered in the analysis.

The results of the *SS* removal (Figure 6.17) indicate majority of the biofilm solids in the reactor effluents are smaller than 90 μm for all reactors. For the best performance during application of full scale SF with larger sieve openings, SF machines should be used on reactor 5 since *SS* removal is consistently higher than other studied sieves.

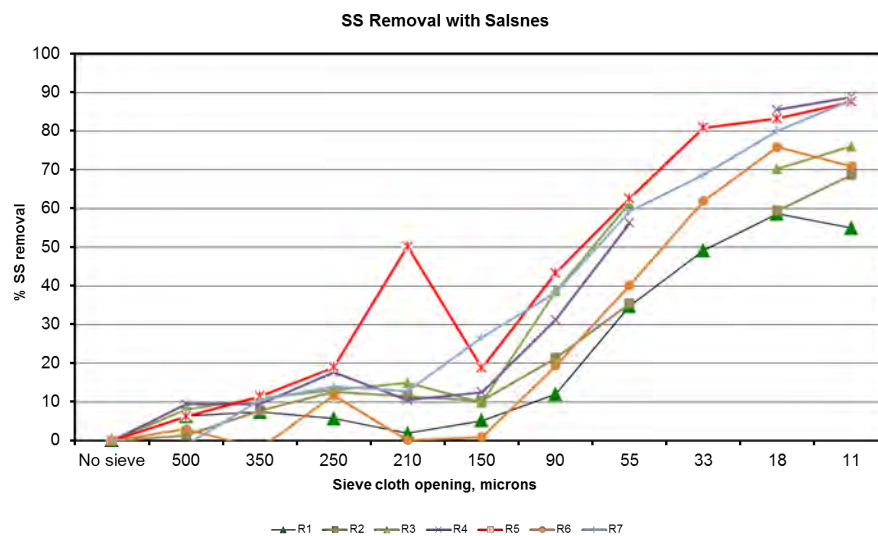

Figure 6.17: SS Removal Efficiencies with SF Sieves for NFR MBBR R5 Effluent

The results of the *COD* removal (Figure 6.18) by SF sieves follow the trend of *SS* removal. For the unflocculated reactor effluent, the *COD* removed are particulate in nature. Where *COD* is not added (reactor 1 to 5), the Particulate Chemical Oxygen Demand (*PCOD*) range

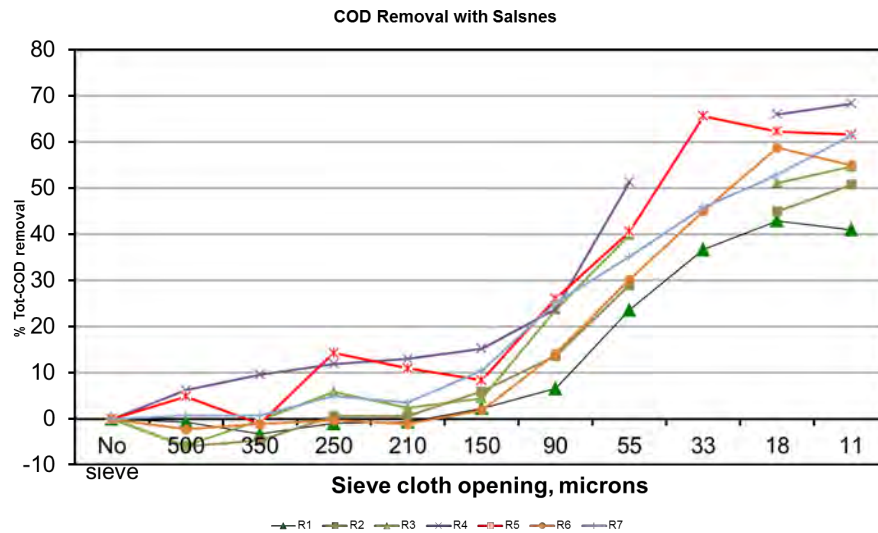

Figure 6.18: COD Removal Efficiencies with SF Sieves for NFR MBBR R5 Effluent

from more than 0% to less than 70% of the total COD present in the reactor effluent (Figure 6.19). Also evident from Figure 6.19, the particulate COD increases with the wastewater retention time in the system. The increase in PCOD is a direct consequence of both (a) removal of COD from the bulk liquid by biomass for growth and (b) detachment of biofilm from the carriers when the biofilm exceeded the optimal biofilm thickness.

6.6.1.2 Hydraulic Capacities and Filtration Rates for Full Scale Operation

The mean hydraulic capacities of SF sieves for reactor effluents when operating with mat formation are presented in Figure 6.20. A mat may form on the top of the sieve cloth due to the accumulation of solids and is analogous to a filter cake. Hydraulic capacity for operating the apparatus with mat formation is defined as

$$\text{Hydraulic Capacity}_{\text{mat}} = \frac{\text{Volume}_{(300\text{mm} \rightarrow 200\text{mm})} (\text{m}^3)}{\text{Area}_{\text{cloth}} (\text{m}^2_{\text{cloth}}) \cdot \text{Time}_{\text{filtration (300mm} \rightarrow 200\text{mm)}} (\text{hour})} \quad (6.2)$$

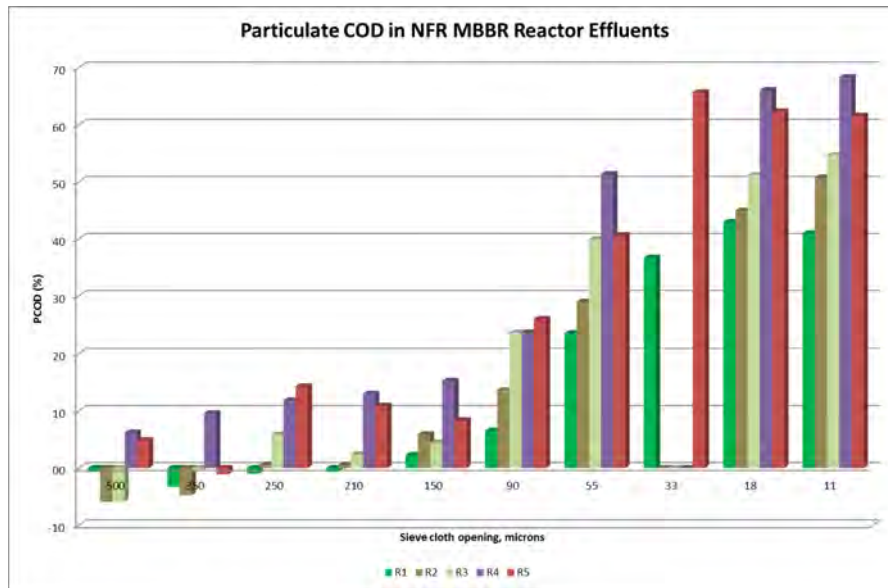

Figure 6.19: Variation of particulate COD in different NFR MBBR reactor effluent

It should be noted hydraulic capacities for sieves with larger light openings that did not result in (1) clogging with the first litre; (2) formation of a mat within a defined quantity of wastewater sample; and (3) would result in mat formation with larger volumes filtered, were not calculated for this study. Only results with mat formation after the first litre of sieving are considered in the analysis; where mat formation might occur in larger sieve light opening ($> 250 \mu\text{m}$), due to the high hydraulic capacities and lowered *SS* removal, these data were not considered. Where mat formation is occurring during the first litre filtration, the results are included in the discussion below and not included in this discussion.

Figure 6.20 shows calculated hydraulic capacities and mean *SS* removal efficiencies of different sieves when operating the apparatus with mat formation for NFR MBBR reactor 5 effluent. *SS* removal from the first litre of sampled effluent are included in Figure 6.20 for comparison between mat formation and without mat formation within a sieve light opening size. The results show in general an inverse relationship between the hydraulic capacity and *SS* removal.

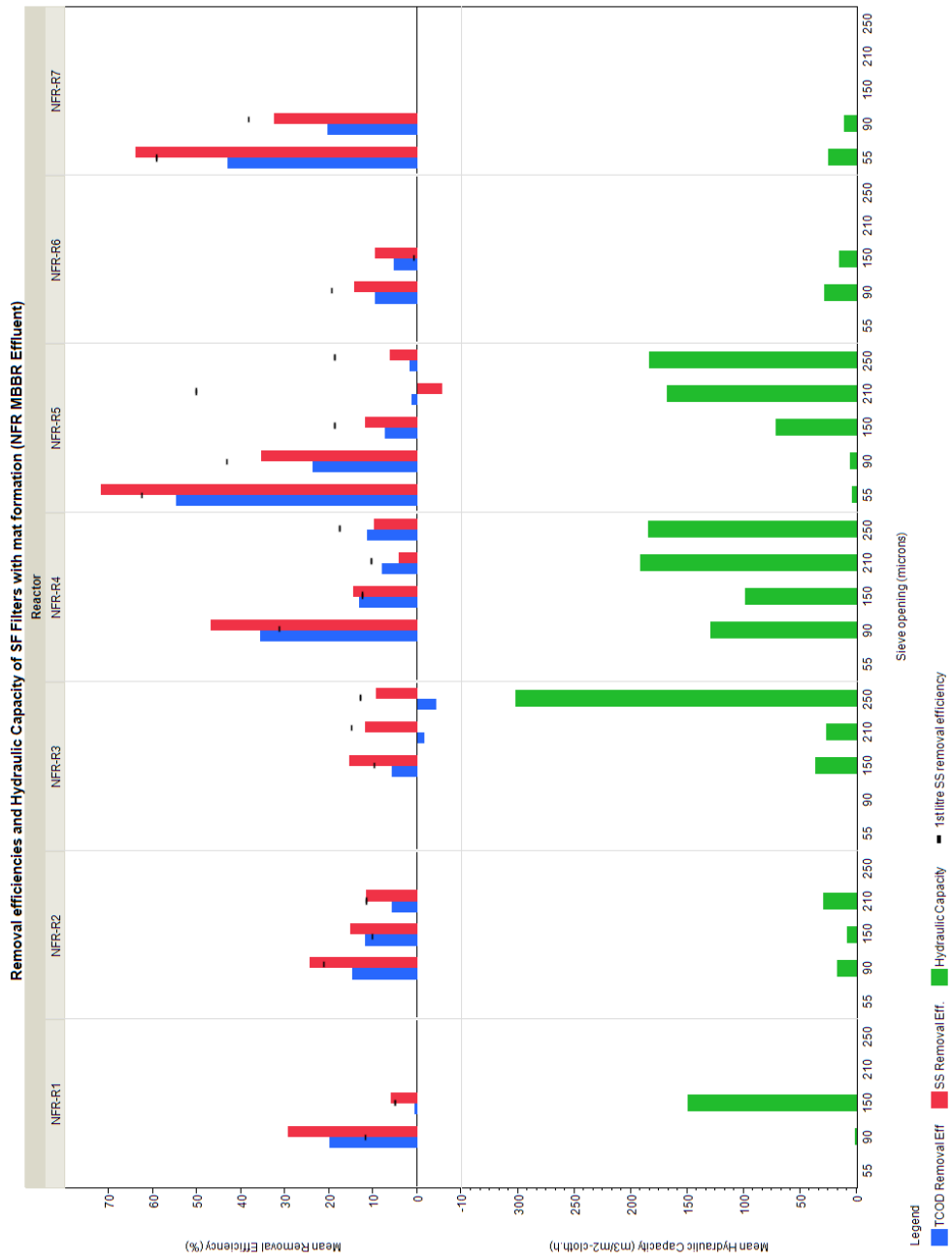

Figure 6.20: Removal efficiencies and mean hydraulic capacity of SF sieves for NFR MBBR R5 Effluent with mat formation.

The formation of a mat on the sieve cloths was dependent on the reactor and the light openings of the sieve cloth: from Figure 6.20, a mat formation for Reactor 1 is only possible with 90 and 150 μm sieve cloths but in Reactor 5, mat formation is achieved with sieve cloths from 55 to 250 μm . In all cases, the sieve cloths were clogged almost immediately after the formation of a mat, resulting in very low hydraulic capacities after mat formation. What this means when operating a SF machine is that the sieve cloth must be continuously replaced through rotation and cleaning in order to maintain a constant throughput. The results suggest the possibility of formation of a mat after the first litre filtered on larger light openings of sieve cloths increases with decreasing organic loading on the reactor.

The results suggest that SS removal efficiency may be lowered when operating the equipment with mat formation compared to simple sieving (without mat formation) when the sieve light opening are larger than 210 μm . The low SS removal associated with larger sieve light opening would exclude the use of these sieves where SS of the filtered effluent do not meet discharge standards.

The mean hydraulic capacities of SF sieves for reactor effluents when operating without mat formation is presented in Figure 6.21. Hydraulic capacity for operating the apparatus with mat formation is defined as

$$\text{Hydraulic Capacity}_{\text{no mat}} = \frac{\text{Volume}_{\text{filtered during 1st litre}} (\text{m}^3)}{\text{Area}_{\text{cloth}} (\text{m}^2_{\text{cloth}}) \cdot \text{Time}_{\text{filtration}} (\text{hour})} \quad (6.3)$$

Sieve cloths with smaller light openings ($\leq 55 \mu\text{m}$) tend to be clogged during filtering the first litre and because data associated to the filtered volume and filtration time was not collected during this study, assumptions were made to enable the calculation of hydraulic capacities. Appendix B.1 shows the assumption of the volume of SF effluent filtered with the associated sieves with an assumed filtration time of

30 seconds. The assumption of 30 seconds filtration and the associated filtered volume is likely to fall on the conservative side and the actual hydraulic capacities may likely be higher than those presented here. Hydraulic capacities for operating without mat were calculated only for sieves that are clogged within the first litre of effluent filtered; the hydraulic capacities for sieves with larger light opening that did not result in clogging with the first litre were considered sufficiently large and would result in mat formation with sufficient volume filtered and hence not considered herewith.

The hydraulic capacities of the sieves show an inverse relationship to the SS removal: larger sieve light openings resulted in lower SS removal but was able to filter more volume of effluent before being clogged. The hydraulic capacities of the sieves ranged from $0.2 \text{ m}^3/\text{m}_{\text{sieve}}^2 \cdot \text{h}$ for $11 \text{ }\mu\text{m}$ sieves to $3.0 \text{ m}^3/\text{m}_{\text{sieve}}^2 \cdot \text{h}$ for $55 \text{ }\mu\text{m}$ sieves. An alternative presentation of the results is attached in Appendix B.2. The results show the general trend of decreasing removal efficiencies with increasing hydraulic capacities and hydraulic capacities can be increased by using sieve cloths with larger light openings. The significantly lower hydraulic capacities of smaller light opening sieve cloths would mean that when operating a full scale SF machine, in order for the operator to maintain the throughput of the machine, the speed of rotating belt carrying clean sieve must be increased significantly relative to operating with mat formation.

6.6.2 *Application to Flocculated NFR MBBR Reactor 5 Effluent*

6.6.2.1 *Suspended Solids and Chemical Oxygen Demand Removal*

The results of the SS and COD removal with SF sieves for flocculated NFR MBBR reactor 5 effluent are presented in Figures 6.22, 6.23, 6.24 and 6.25. As before, the results show an improvement in SS removal with decreasing light opening on the fine mesh sieves. A difference

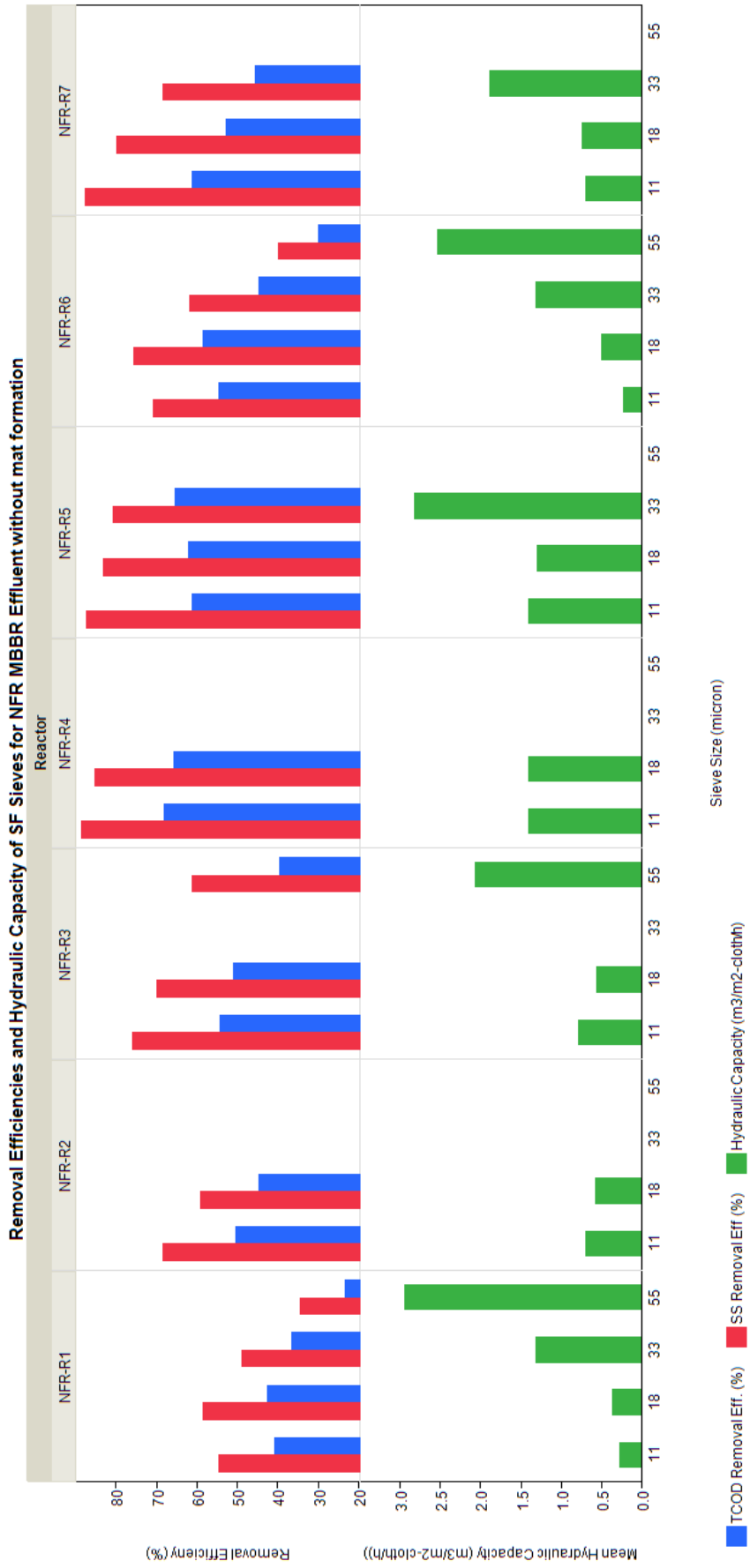

Figure 6.2.1: Removal Efficiencies and mean hydraulic capacity of SF sieves for NFR MBBR R5 Effluent without mat formation

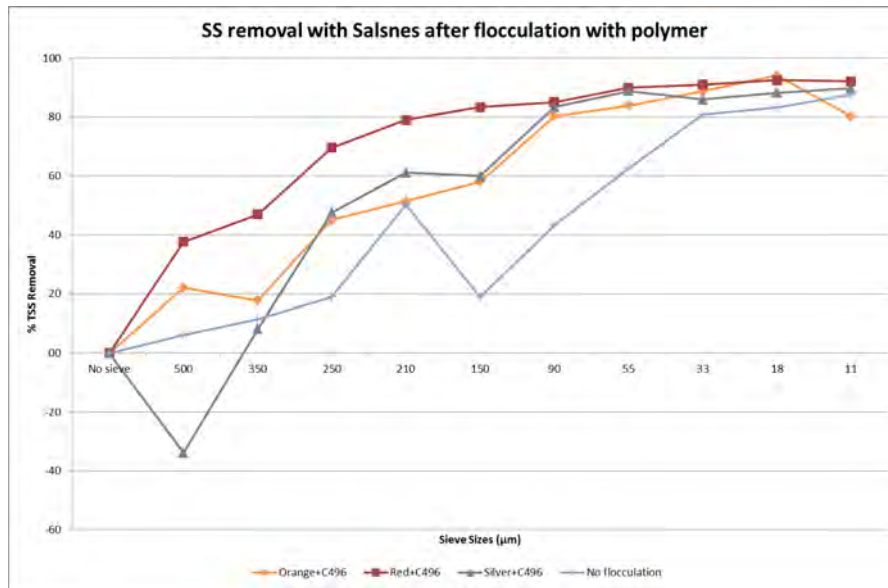

Figure 6.22: SS Removal Efficiencies with SF Sieves for polymer flocculated NFR MBBR reactor 5 effluent

in SS removal between the 3 stirrers can be seen in the figures and the best removals occurred when using the red stirrer for mixing and flocculation.

A difference in SS removal between the polymer-based flocculant and aluminium-based flocculant can be seen especially at the larger sieve light opening (sieve sizes larger than 55 µm), with the polymer-based flocculant achieving higher SS removal than the aluminium-based flocculant. When flocculating with polymer (Figure 6.22), it was possible to achieve better SS removal compared to the unflocculated reactor effluent which may be necessary to meet effluent SS discharge requirements. SS removal with polymer is highest with the red mixer with 80% removal achieved with 210 µm sieve cloth compared to 90 µm sieve with silver mixer, 55 µm sieve with the orange mixer and 33 µm without flocculation.

On the other hand, when flocculating with aluminium-based flocculant (Figure 6.23), there was an increase in the SS of the reactor effluent, likely due to formation of aluminium hydroxides flocs, especially with larger sieve light opening (sieve sizes larger than 55 µm).

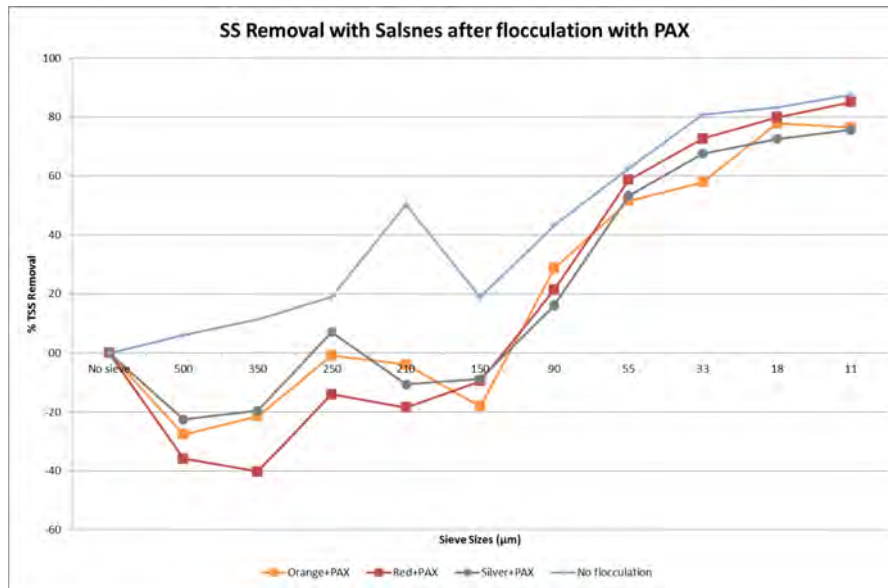

Figure 6.23: SS Removal Efficiencies with SF Sieves for PAX flocculated NFR MBBR reactor 5 effluent

SS removal was significantly lower compared with unflocculated reactor effluent. It is possible to achieve 80% SS removal with 33 µm sieve without flocculation but with flocculation with PAX XL-60, sieve cloths with light opening less than 18 µm had to be used. Therefore, when considered against effluent SS discharge requirements, the increased SS concentration in discharge may not be desirable.

The results of the COD removal (Figures 6.24 and 6.25) by SF sieves follow the trend of SS removal, i.e. increasing COD removal with decreasing light opening on the fine mesh sieves. Similar to the SS studies presented above, the best PCOD removal resulted from the use of the red stirrer. As can be seen from the figures the capture of PCOD from the reactor effluent differ when using polymer-based and aluminium-based flocculants. Flocculation with polymer resulted in more PCOD removal with larger mesh openings (for example with the red mixer, 60% removal with 150 µm sieve cloth compared to 60% removal with 55 µm for PAX XL-60)

With polymer, it was observed better COD removal is achieved relative to the unflocculated reactor effluent. This increased removal may

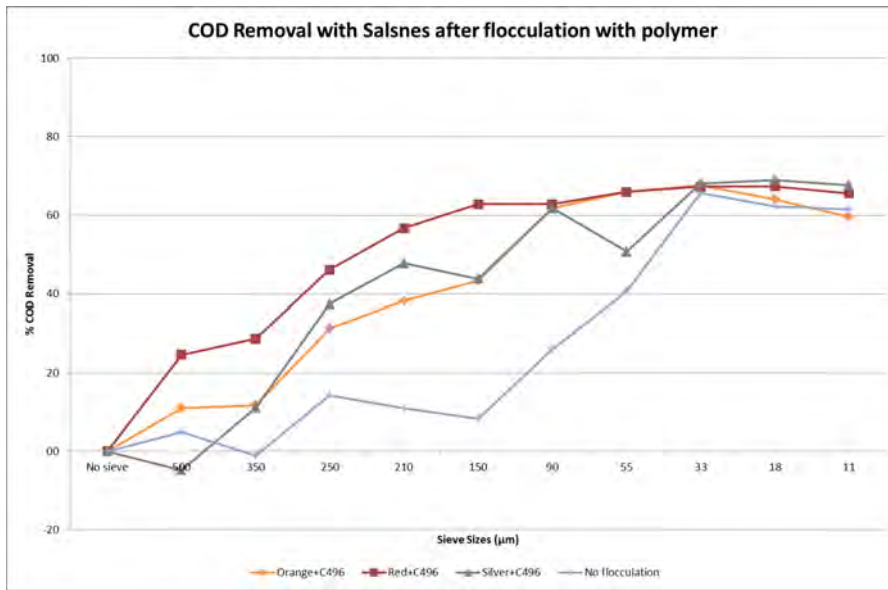

Figure 6.24: COD Removal Efficiencies with SF Sieves for polymer flocculated NFR MBBR reactor 5 effluent

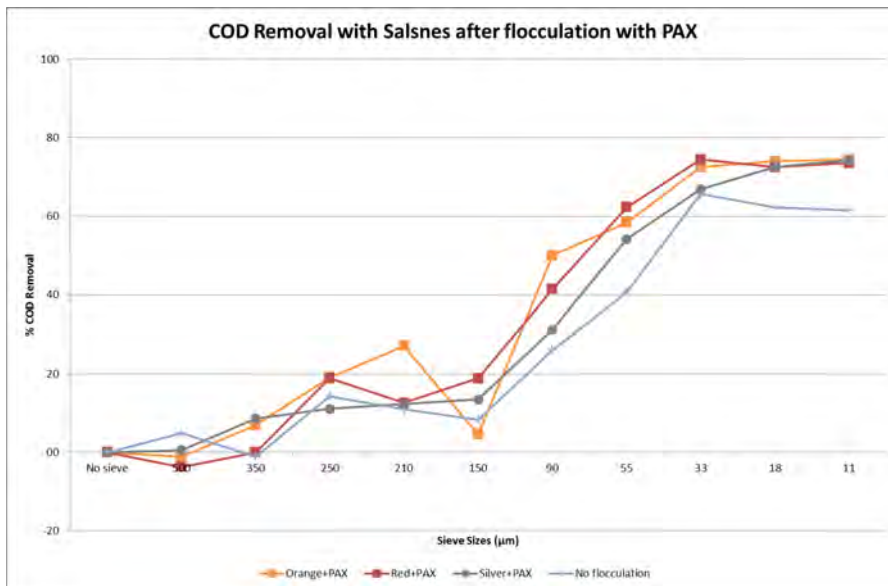

Figure 6.25: COD Removal Efficiencies with SF Sieves for PAX flocculated NFR MBBR reactor 5 effluent

be attributed to the aggregation of biofilm solids into larger flocs and the COD was removed through the sieving process.

There was no negative COD removal when flocculating with aluminium flocculant as compared to the SS removal since the addition of the flocculant does not contribute to the COD of the studied effluent. Hence the COD removal with aluminium-based flocculant followed the closely to the unflocculated reactor effluent.

The results also suggest that the biofilm solids are as aggregated into larger flocs as compared to flocculation with polymer. Hence, where the application of flocculation is for COD removal with larger sieve sizes, this study suggests the use of polymer-based flocculant over aluminium-based flocculant.

6.6.2.2 *Suspended Solids Distribution of Flocculated NFR MBBR Reactor 5 Effluent*

Figure 6.26 shows the results of SS size distribution obtained from the benchscale SF test apparatus with (1) an outlier point at 210 μm for non-flocculated effluent removed and (2) the SS concentration for flocculation with PAX XL60 rebased to 500 μm SS concentration. The original data is attached in Appendix B.3. The results show a shift in SS size distribution when flocculating with PAX XL-60 and with Superfloc C496. Flocculating with Superfloc C496 resulted in a shift towards larger floc sizes whereas flocculating with PAX XL-60 resulted in a shift towards smaller floc sizes.

6.6.2.3 *Hydraulic Capacities and Filtration Rates for Full Scale Operation*

The calculations for full scale operations with flocculated MBBR effluent follow that as described in Section 6.6.1.2.

The mean hydraulic capacities of SF sieves for reactor effluents when operating with mat formation is presented in Figure 6.27. With flocculation of Reactor 5 effluent, mat formation was possible with sieve cloths with larger light openings (150 μm to 350 μm). Floccula-

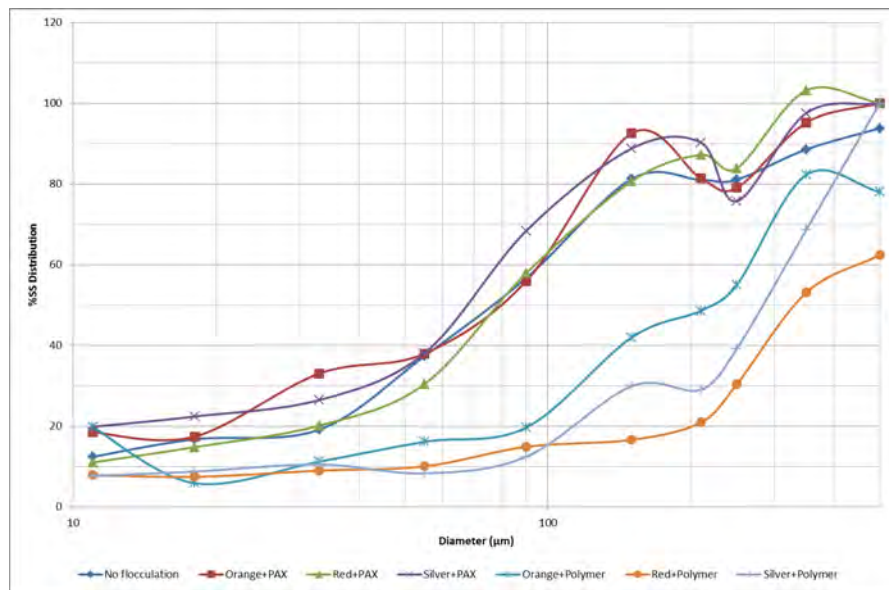

Figure 6.26: Suspended solids size distribution from Salsnes Filters Test Apparatus

tion of the effluent prior to sieving with SF resulted in smaller range of sieve cloths suitable for forming mat before clogging: without flocculation, it was possible to use up to 5 different light opening sieve but the range was reduced to a maximum of 3 with flocculation.

It can be seen from Figure 6.27, the hydraulic capacities for 250 μm SF sieves are significantly higher ($P = 0.1$) when flocculating with PAX XL-60. With Superfloc C496, it was possible to use 250 μm sieve cloth to achieve higher SS removal (70%) compared to filtration without mat formation and at $10 \text{ m}^3/\text{m}^2_{\text{sieve}} \cdot \text{h}$. The deteriorated SS removal efficiency with PAX XL-60 after mat formation could be due to the breakup of flocs during the filtration process: breakup of the flocs may have resulted when shear forces generated from the velocity and pressure of the water column passing through the mat exceeded the floc strength.

Figure 6.28 shows the average distribution of hydraulic capacities of SF sieves when operating with mat formation.

The mean hydraulic capacities of SF sieves for reactor effluents when operating without mat formation are presented in Figure 6.29.

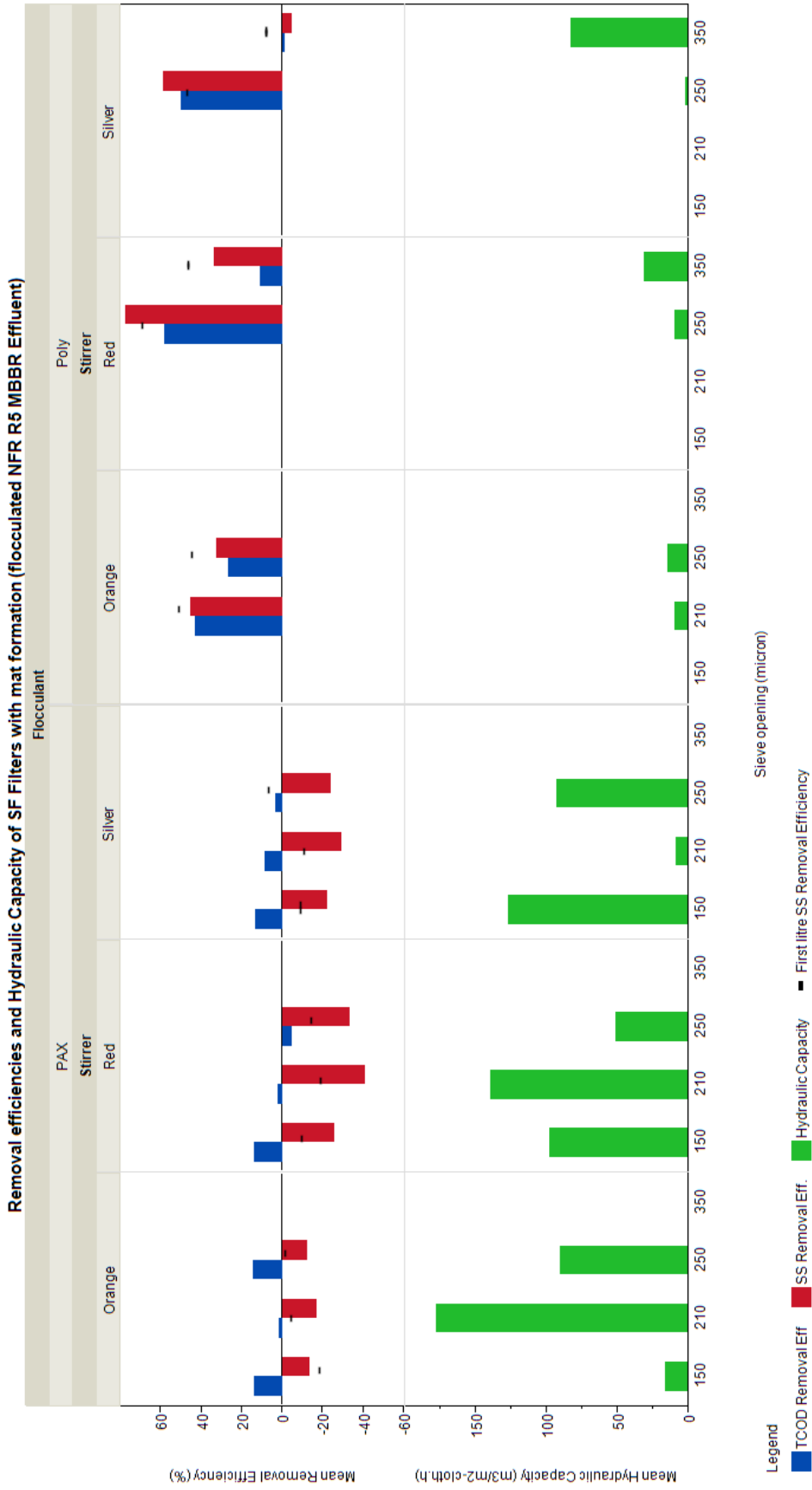

Figure 6.27: Removal Efficiencies and mean hydraulic capacity of SF Sieves for flocculated MBBR effluent with mat formation. PAX refer to PAX XL-60 and Poly refers to Superfloc C496.

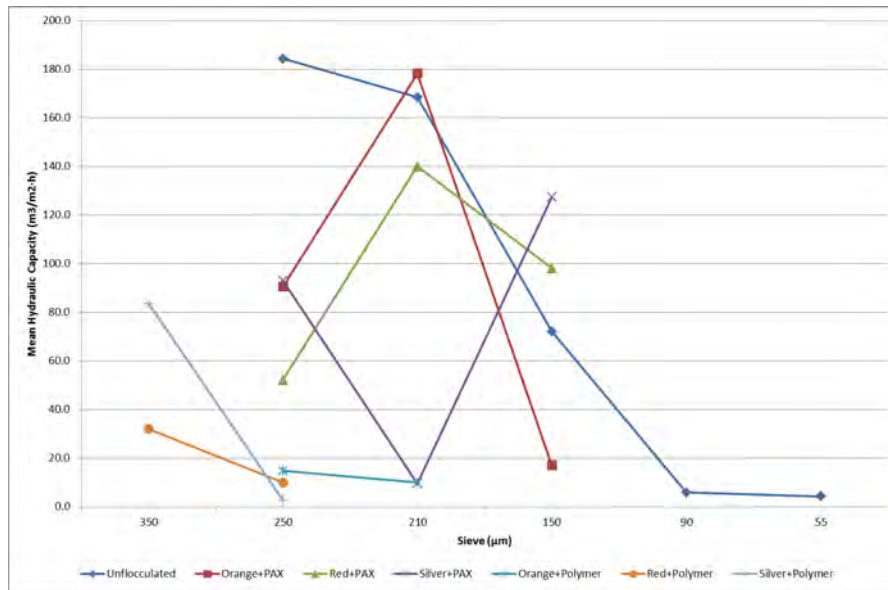

Figure 6.28: Comparison of mean hydraulic capacity of SF sieves for unfloculated and flocculated MBBR effluent with mat formation

Like discussed above, the hydraulic capacities of the sieves show an inverse relationship to the *SS* removal: larger sieve light openings resulted in lower *SS* removal but was able to filter more volume of effluent before being clogged. The hydraulic capacities of the sieves ranged from $0.2 \text{ m}^3/\text{m}_{\text{sieve}}^2 \cdot \text{h}$ for $11 \text{ }\mu\text{m}$ sieves to $12.0 \text{ m}^3/\text{m}_{\text{sieve}}^2 \cdot \text{h}$ for $210 \text{ }\mu\text{m}$ sieves. Flocculation with Superfloc C496 allowed for higher hydraulic capacities for all sieve sizes relative to flocculation with PAX XL-60 in addition to achieving better *SS* removal efficiencies. The results indicate it may be possible to use the $210 \text{ }\mu\text{m}$ sieve to achieve 80% *SS* removal and with a conservative estimated hydraulic capacity of $10 \text{ m}^3/\text{m}_{\text{sieve}}^2 \cdot \text{h}$ on a full scale SF machine if the MBBR effluent being treated is pre-flocculated with Superfloc C496.

Figure 6.29 shows the average distribution of hydraulic capacities of SF sieves when operating without mat formation.

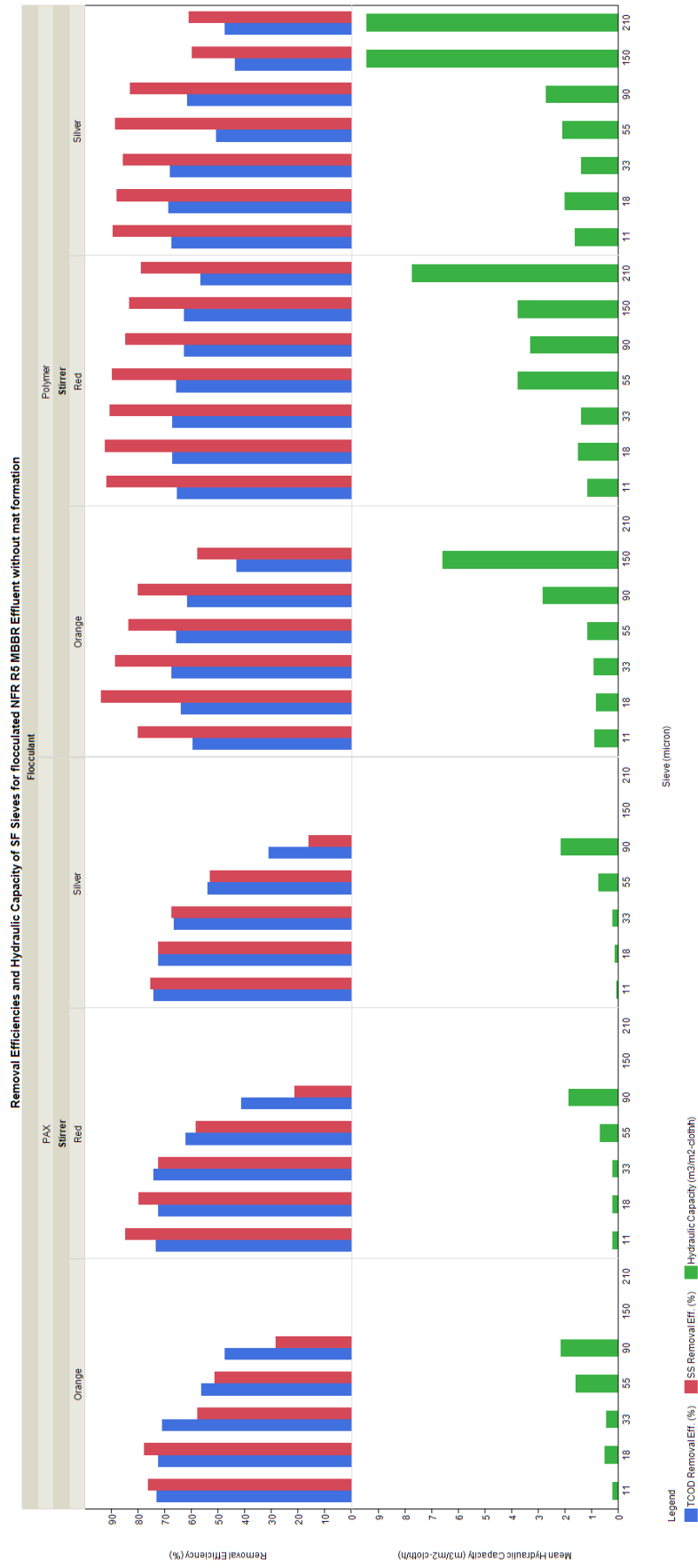

Figure 6.29: Removal Efficiencies and mean hydraulic capacity of SF Sieves for flocculated MBBR effluent without mat formation

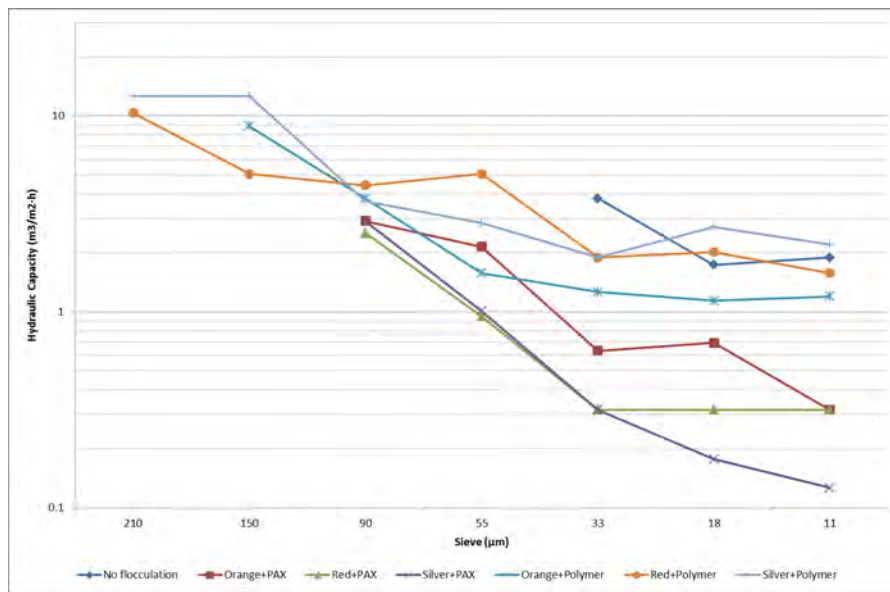

Figure 6.30: Comparison of mean hydraulic capacity of SF sieves for unflocculated and flocculated MBBR effluent with mat formation

Part V

CONCLUSIONS AND FUTURE WORKS

CONCLUSIONS

7.1 CONCLUSIONS

The municipal wastewater received by NFR for treatment over the period was subjected to weather and climatic influences resulting in variable hydraulic and organic loading on the MBBR for biological nitrogen removal. Particles in the MBBR effluents from all 7 MBBR reactors were characterized by Malvern Mastersizer 3000 and by SF benchscale test apparatus. The PSDs were found to vary according to the organic loading on the individual reactors: higher organic loading resulted in smaller particle volumes and the particle size peaked around 100 μm in diameter. The SS distribution mirrored the trend of the PSD obtained by Malvern Mastersizer, i.e. higher percentage of SS are larger in size with decreasing organic loading.

Among the sixteen flocculants screened for turbidity removal for Reactors 5 and 7 in jar test studies, most of cationic polymer-based flocculant and metal-based flocculants had improved turbidity removal and outperformed the anionic polymer-based flocculants. 4 cationic polymers (Superfloc C-491K and Superfloc C-496 from Kemira, and Zetag 9046FS and Zetag 9068FS from BASF) and 2 metal-based chemicals (PAX XL-60 and ferric chloride from Kemira) were selected for further jar testing studies.

The jar test results for optimal dosing for NFR MBBR reactor 5 effluent showed marginal improvement of some cationic polymer-based flocculants and dosing beyond an optimal dosage resulted in decreased SS removal. Polyaluminium hydroxide based flocculant (PAX XL-60) had the best SS removal (90%) among the flocculants

studied. 2 flocculants were selected for further study of mixing intensity and time: 2 mg/l of Superfloc C-496 and 8 mg/l of PAX XL-60.

The formation of flocs and the efficiency of SS removal was found to be a function of both mixing and flocculation. The best SS removal is achieved when with 15 minutes of flocculation at 50 rpm of flocculation intensity for both polymer-based and aluminium-based flocculant: 75% and 55% respectively. The mixing and flocculation program selected for the pilot scale flocculation studies was 20 seconds of rapid mixing at 300 rpm followed by 15 minutes of flocculation at 50 rpm.

The use of Malvern Mastersizer 3000 for the online characterization of flocculation enabled the flocculation time during pilot scale flocculation studies to be optimised. It was found that with Superfloc C496, the minimum flocculation time for the maximum floc size to be achieved is 3 minutes whereas with PAX XL60, the minimum flocculation time is 9 minutes. Image analysis of the flocs also suggest stirrer design and flocculant have an influence on the shape and structure of the flocs.

The SS and COD removal efficiencies of SF sieves cloths for unflocculated reactor effluent increased with increasing HRT, decreased organic loading and decreasing light opening of the sieves. The formation of a mat on the sieve cloth during filtration was found to reduce SS removal for some sieves and the mat were found to be clogged quickly after formation. Higher hydraulic capacities lead to lower SS removal efficiencies in most cases and the hydraulic capacities decreased with decreasing light opening.

Flocculation changed the particle size characteristics of the reactor effluent and the hydraulic capacities of the sieve cloths. When flocculating with Superfloc C496, the particle size distribution is shifted towards larger size range and the SS removal efficiency improved for SF sieves in the larger light opening ranges but resulted in reduced hydraulic capacities. When flocculating with PAX XL-60, the percentage of smaller particle sizes increased, low SS removal efficiencies were

achieved with negative removal in the larger light opening ranges and lowered hydraulic capacities.

7.2 RECOMMENDATIONS FOR FUTURE WORKS

The application of the SF sieve for separation of biofilm solids and particles from MBBR reactor effluents showed promising results. Recommendations for further study of the system include:

1. Operation of a pilot scale SF machine for the verification of SS removal efficiencies, hydraulic capacities and filtration rates of the various sieves.
2. Operation of a pilot scale SF machine coupled with a pre-flocculation unit to investigate the SS removal efficiencies, hydraulic capacities and filtration rates of the various sieves and various pre-flocculation methods.
3. Investigate the effects of pre-flocculated effluent on the sieve cloths, the cleaning efficiencies of the machine and the power requirements of the machine.
4. Conduct a life cycle analysis of the different pre-flocculation options

REFERENCES

- AWWA (1999). "2540 solids." AWWA. (Cited on page 45.)
- Bratby, J. (2006). *Coagulation and flocculation in water and wastewater treatment*. IWA Publishing. (Cited on pages 22, 23, 24, 25, 26, and 27.)
- Brezonik, P. and Arnold, W. (2011). *Water Chemistry: An Introduction to the Chemistry of Natural and Engineered Aquatic Systems*. Oxford University Press, USA, 1st edition. (Cited on page 23.)
- Camp, T. and Stein, P. (1943). "Velocity gradients and internal work in fluid motion." *Journal of the Boston Society of Civil Engineers*, 30(4), 219–237. (Cited on page 26.)
- Costerton, B., Stoodley, P., and Dirckx, P. (2003). "Complexity of biofilms, <<http://www.biofilm.montana.edu/resources/images/biofilm-general-interest/complexity-biofilms.html>>. (Cited on pages xii and 9.)
- Ødegaard, H., Cimbritz, M., Christensson, M., and Dahl, C. P. (2010). "Separation of biomass from moving bed biofilm reactors (mbbrs)." *Proceedings of the Water Environment Federation*, 2010(7), 212–233. (Cited on pages 3, 18, 19, 20, and 27.)
- Ødegaard, H., Gisvold, B., and Strickland, J. (2000). "The influence of carrier size and shape in the moving bed biofilm process." *Water Science and Technology*, 41(4-5), 383 – 391. (Cited on page 14.)
- Ødegaard, H., Rusten, B., and Westrum, T. (1994). "A new moving bed biofilm reactor - applications and results." *Water Science and Technology*, 29(10-11), 157–165. (Cited on page 12.)

- Donlan, R. M. (2002). "Biofilms: Microbial life on surfaces." *Emerging Infectious Diseases*, 8(9), 881–890. (Cited on page 7.)
- Droste, R. L. (1997). *Theory and Practice of Water and Wastewater Treatment*. John Wiley & Sons, Ltd., 1st edition. (Cited on page 23.)
- Ekama, G. A. and Wentzel, M. (2008). *Biological Wastewater Treatment: Principles, Modelling and Design*. IWA Publishing, Chapter Organic Matter Removal, 53–86. (Cited on pages 2 and 18.)
- Grady, C., Daigger, G., and Lim, H. (1999). *Biological wastewater treatment*. Environmental science and pollution control series. Marcel Dekker. (Cited on pages 2, 10, and 12.)
- Hach-Lange (2008). "Lange cuvette test: The system for photometric water analysis." *Report no.*, Hach-Lange GmbH. (Cited on pages 29 and 31.)
- Henze, M., van Loosdrecht, M. C., Ekama, G. A., and Brdjanovic, D. (2008). *Biological Wastewater Treatment: Principles, Modelling and Design*. IWA Publishing, Chapter Wastewater Treatment Development, 1–7. (Cited on page 2.)
- Åhl, R. M., Leiknes, T., and Odegaard, H. (2006). "Tracking particle size distributions in a moving bed biofilm membrane reactor for treatment of municipal wastewater." *Water Science and Technology*, 53(7), 33 – 42. (Cited on page 59.)
- ISO (2002). "Iso 15705:2002 : Determination of the chemical oxygen demand index (st-cod) – small-scale sealed-tube method." International Standards Office. (Cited on page 29.)
- ISO (2004). "Iso 6878:2004 : Water quality - determination of phosphorus - ammonium molybdate spectrometric method." International Standards Office. (Cited on page 31.)

- Jarvis, P., Jefferson, B., Gregory, J., and Parsons, S. (2005). "A review of floc strength and breakage." *Water Research*, 39(14), 3121 – 3137. (Cited on pages 22 and 26.)
- Leiknes, T. and Ødegaard, H. (2007). "The development of a biofilm membrane bioreactor." *Desalination*, 202(1-3), 135 – 143 *Wastewater Reclamation and Reuse for Sustainability*. (Cited on page 59.)
- Löfqvist, A. and Welander, T. (2007). "Method for biological purification of water using a carrier material (March). (Cited on page 14.)
- Ljunggren, M. (2006). "Micro screening in wastewater treatment - an overview." *Vatten*, 2, 171–178. (Cited on pages 18 and 60.)
- Madigan, M., Martinko, J., Stahl, D., and Clark, D. (2011). *Brock Biology of Microorganisms*. Pearson Education, 13 edition. (Cited on page 7.)
- Malvern (2011). *Mastersizer 3000 User Manual (MANo474)*. Malvern Instruments ktd., Malvern Instruments Ltd. Enigma Business Park, Grovewood Road, Malvern, Worcestershire WR14 1XZ United Kingdom., 1 edition (October). (Cited on page 33.)
- Melin, E., Leiknes, T., Helness, H., Rasmussen, V., and Odegaard, H. (2005). "Effect of organic loading rate on a wastewater treatment process combining moving bed biofilm and membrane reactors." *Water Science and Technology*, 51(6-7), 421 – 430. (Cited on page 59.)
- Morgenroth, E. F. (2008). *Biological Wastewater Treatment: Principles, Modelling and Design*. IWA Publishing, Chapter Biofilm Reactors, 493–511. (Cited on page 3.)
- NFR (2012). "Nordre follo renseanlegg." Nordre Follo Renseanlegg, <<http://www.nfra.no/>>. (Cited on pages xii, 13, and 14.)
- Nussbaum, B. L., Soros, A., Mroz, A., and Rusten, B. (2006). "Removal of particulate and organic matter from municipal and industrial wastewaters using fine mesh rotating belt sieves." *Proceedings*

- of the Water Environment Federation*, 2006(10), 3052–3056. (Cited on pages 20 and 22.)
- Odegaard, H. (1996). “Reactor for purification of water (August). (Cited on page 12.)
- Pütz, P. (2010). “10x cod: a cod range for every application.” *Practical report*, Hach-Lange GmbH (09). (Cited on page 31.)
- Rusten, B. (2004). “Development of a simple test apparatus and procedure to predict the full scale treatment performance of salsnes filter fine mesh sieves - preliminary testing.” *Aquateam Report No. 04-002*, Aquateam (January). (Cited on pages 39, 60, and 76.)
- Rusten, B. (2012). “Technical data for salsnes filter [email] (personal communication, 25 may 2012). Personal communication. (Cited on page 20.)
- Rusten, B. and Ødegaard, H. (2006). “Evaluation and testing of fine mesh sieve technologies for primary treatment of municipal wastewater.” *Water Science and Technology*, 54(10), 31–38. (Cited on page 3.)
- Rusten, B. and Lundar, A. (2006). “How a simple bench-scale test greatly improved the primary treatment performance of fine mesh sieves.” *Proceedings of the Water Environment Federation*, 2006(11), 1919–1935. (Cited on pages 4, 39, 40, 46, and 60.)
- Rusten, B. and Paulsrud, B. (2008). “Kapasitetsvurdering av nordre follo resnseanlegg (capacity assessment of nordre follo wastewater treatment plant) (in norwegian).” *Report No. 08-002*, Aquateam - Norsk vannteknologisk senter A/S (January). (Cited on pages 15 and 57.)
- SalsnesFilter (2012). “Salsnes filters.” Salsnes Filters AS, <<http://www.salsnes-filter.com/public.aspx?pageid=44774>>. (Cited on page 22.)

- Søraker, J. M. (2012). "Kemira flocculator and associated g-value [email] (personal communication, 13 march 2012). Personal communication. (Cited on pages 33 and 70.)
- Tchobanoglous, G., Burton, F., Stensel, H., and Eddy, M. . (2003). *Wastewater Engineering: Treatment and Reuse*. McGraw-Hill Series in Civil and Environmental Engineering. McGraw-Hill, 4th edition. (Cited on pages 2, 3, 10, 11, 12, 14, 19, 23, and 33.)
- Thomas, D., Judd, S., and Fawcett, N. (1999). "Flocculation modelling: a review." *Water Research*, 33(7), 1579 – 1592. (Cited on page 23.)
- Väänänen, M., Kupiainen, L., Rämö, J., Sarpola, A., and Tanskanen, J. (2012). "Speciation and coagulation performance of novel coagulant - aluminium formate." *Separation and Purification Technology*, 86(0), 242 – 247. (Cited on page 33.)
- Watnick, P. and Kolter, R. (2000). "Biofilm, city of microbes." *Journal of Bacteriology*, 182(10), 2675–2679. (Cited on page 7.)
- Wiesmann, U., Choi, I. S., and Dombrowski, E.-M. (2007). *Fundamentals of Biological Wastewater Treatment*. Weinheim : Wiley-VCH. (Cited on pages 10 and 12.)

Part VI

APPENDIX



STANDARD PROCEDURES

The standard procedures used for analyses within this study are attached.

A.1 AWWA STANDARD METHODS FOR WATER AND WASTEWATER ANALYSIS 2540D

Standard Methods for the Examination of Water and Wastewater

average weight. If volatile solids are to be determined, follow procedure in Section 2540E.

4. Calculation

$$\text{mg total dissolved solids/L} = \frac{(A - B) \times 1000}{\text{sample volume, mL}}$$

where:

A = weight of dried residue + dish, mg, and

B = weight of dish, mg.

5. Precision

Single-laboratory analyses of 77 samples of a known of 293 mg/L were made with a standard deviation of differences of 21.20 mg/L.

6. Reference

1. SOKOLOFF, V.P. 1933. Water of crystallization in total solids of water analysis. *Ind. Eng. Chem., Anal. Ed.* 5:336.

7. Bibliography

- HOWARD, C.S. 1933. Determination of total dissolved solids in water analysis. *Ind. Eng. Chem., Anal. Ed.* 5:4.
- U.S. GEOLOGICAL SURVEY. 1974. Methods for Collection and Analysis of Water Samples for Dissolved Minerals and Gases. Techniques of Water-Resources Investigations, Book 5, Chap. A1. U.S. Geological Surv., Washington, D.C.

2540 D. Total Suspended Solids Dried at 103–105°C

1. General Discussion

a. Principle: A well-mixed sample is filtered through a weighed standard glass-fiber filter and the residue retained on the filter is dried to a constant weight at 103 to 105°C. The increase in weight of the filter represents the total suspended solids. If the suspended material clogs the filter and prolongs filtration, it may be necessary to increase the diameter of the filter or decrease the sample volume. To obtain an estimate of total suspended solids, calculate the difference between total dissolved solids and total solids.

b. Interferences: See Section 2540A.2 and Section 2540B.1. Exclude large floating particles or submerged agglomerates of nonhomogeneous materials from the sample if it is determined that their inclusion is not representative. Because excessive residue on the filter may form a

Standard Methods for the Examination of Water and Wastewater

water-entrapping crust, limit the sample size to that yielding no more than 200 mg residue. For samples high in dissolved solids thoroughly wash the filter to ensure removal of dissolved material. Prolonged filtration times resulting from filter clogging may produce high results owing to increased colloidal materials captured on the clogged filter.

2. Apparatus

Apparatus listed in Section 2540B.2 and Section 2540C.2 is required, except for evaporating dishes, steam bath, and 180°C drying oven. In addition:

Aluminum weighing dishes.

3. Procedure

a. Preparation of glass-fiber filter disk: If pre-prepared glass fiber filter disks are used, eliminate this step. Insert disk with wrinkled side up in filtration apparatus. Apply vacuum and wash disk with three successive 20-mL portions of reagent-grade water. Continue suction to remove all traces of water, turn vacuum off, and discard washings. Remove filter from filtration apparatus and transfer to an inert aluminum weighing dish. If a Gooch crucible is used, remove crucible and filter combination. Dry in an oven at 103 to 105°C for 1 h. If volatile solids are to be measured, ignite at 550°C for 15 min in a muffle furnace. Cool in desiccator to balance temperature and weigh. Repeat cycle of drying or igniting, cooling, desiccating, and weighing until a constant weight is obtained or until weight change is less than 4% of the previous weighing or 0.5 mg, whichever is less. Store in desiccator until needed.

b. Selection of filter and sample sizes: Choose sample volume to yield between 2.5 and 200 mg dried residue. If volume filtered fails to meet minimum yield, increase sample volume up to 1 L. If complete filtration takes more than 10 min, increase filter diameter or decrease sample volume.

c. Sample analysis: Assemble filtering apparatus and filter and begin suction. Wet filter with a small volume of reagent-grade water to seat it. Stir sample with a magnetic stirrer at a speed to shear larger particles, if practical, to obtain a more uniform (preferably homogeneous) particle size. Centrifugal force may separate particles by size and density, resulting in poor precision when point of sample withdrawal is varied. While stirring, pipet a measured volume onto the seated glass-fiber filter. For homogeneous samples, pipet from the approximate midpoint of container but not in vortex. Choose a point both middepth and midway between wall and vortex. Wash filter with three successive 10-mL volumes of reagent-grade water, allowing complete drainage between washings, and continue suction for about 3 min after filtration is complete. Samples with high dissolved solids may require additional washings. Carefully remove filter from filtration apparatus and transfer to an aluminum weighing dish as a support. Alternatively, remove the crucible and filter combination from the crucible adapter if a Gooch crucible is used. Dry for at least 1 h at 103 to 105°C in an oven, cool in a desiccator to balance temperature, and weigh. Repeat the cycle of drying, cooling, desiccating, and weighing until a constant weight is obtained or until the weight change is less than 4% of the previous weight or 0.5 mg, whichever is less. Analyze at least 10% of all samples in duplicate. Duplicate determinations should agree

Standard Methods for the Examination of Water and Wastewater

within 5% of their average weight. If volatile solids are to be determined, treat the residue according to 2540E.

4. Calculation

$$\text{mg total suspended solids/L} = \frac{(A - B) \times 1000}{\text{sample volume, mL}}$$

where:

A = weight of filter + dried residue, mg, and

B = weight of filter, mg.

5. Precision

The standard deviation was 5.2 mg/L (coefficient of variation 33%) at 15 mg/L, 24 mg/L (10%) at 242 mg/L, and 13 mg/L (0.76%) at 1707 mg/L in studies by two analysts of four sets of 10 determinations each.

Single-laboratory duplicate analyses of 50 samples of water and wastewater were made with a standard deviation of differences of 2.8 mg/L.

6. Bibliography

- DEGEN, J. & F.E. NUSSBERGER. 1956. Notes on the determination of suspended solids. *Sewage Ind. Wastes* 28:237.
- CHANIN, G., E.H. CHOW, R.B. ALEXANDER & J. POWERS. 1958. Use of glass fiber filter medium in the suspended solids determination. *Sewage Ind. Wastes* 30:1062.
- NUSBAUM, I. 1958. New method for determination of suspended solids. *Sewage Ind. Wastes* 30:1066.
- SMITH, A.L. & A.E. GREENBERG. 1963. Evaluation of methods for determining suspended solids in wastewater. *J. Water Pollut. Control Fed.* 35:940.
- WYCKOFF, B.M. 1964. Rapid solids determination using glass fiber filters. *Water Sewage Works* 111:277.
- NATIONAL COUNCIL OF THE PAPER INDUSTRY FOR AIR AND STREAM IMPROVEMENT. 1975. A Preliminary Review of Analytical Methods for the Determination of Suspended Solids in Paper Industry Effluents for Compliance with EPA-NPDES Permit Terms. Spec. Rep. No. 75-01. National Council of the Paper Industry for Air & Stream Improvement, New York, N.Y.
- NATIONAL COUNCIL OF THE PAPER INDUSTRY FOR AIR AND STREAM IMPROVEMENT. 1977. A Study of the Effect of Alternate Procedures on Effluent Suspended Solids Measurement. Stream Improvement Tech. Bull. No. 291, National Council of the Paper Industry for Air & Stream Improvement, New York, N.Y.
- TREES, C.C. 1978. Analytical analysis of the effect of dissolved solids on suspended solids

Standard Methods for the Examination of Water and Wastewater

determination. *J. Water Pollut. Control Fed.* 50:2370.

2540 E. Fixed and Volatile Solids Ignited at 550°C

1. General Discussion

a. Principle: The residue from Method B, C, or D is ignited to constant weight at 550°C. The remaining solids represent the fixed total, dissolved, or suspended solids while the weight lost on ignition is the volatile solids. The determination is useful in control of wastewater treatment plant operation because it offers a rough approximation of the amount of organic matter present in the solid fraction of wastewater, activated sludge, and industrial wastes.

b. Interferences: Negative errors in the volatile solids may be produced by loss of volatile matter during drying. Determination of low concentrations of volatile solids in the presence of high fixed solids concentrations may be subject to considerable error. In such cases, measure for suspect volatile components by another test, for example, total organic carbon (Section 5310). Highly alkaline residues may react with silica in sample or silica-containing crucibles.

2. Apparatus

See Section 2540B.2, Section 2540C.2, and Section 2540D.2.

3. Procedure

Ignite residue produced by Method 2540B, C, or D to constant weight in a muffle furnace at a temperature of 550°C. Ignite a blank glass fiber filter along with samples. Have furnace up to temperature before inserting sample. Usually, 15 to 20 min ignition are required for 200 mg residue. However, more than one sample and/or heavier residues may overtax the furnace and necessitate longer ignition times. Let dish or filter disk cool partially in air until most of the heat has been dissipated. Transfer to a desiccator for final cooling in a dry atmosphere. Do not overload desiccator. Weigh dish or disk as soon as it has cooled to balance temperature. Repeat cycle of igniting, cooling, desiccating, and weighing until a constant weight is obtained or until weight change is less than 4% or 0.5 mg, whichever is less. Analyze at least 10% of all samples in duplicate. Duplicate determinations should agree within 5% of their average weight. Weight loss of the blank filter is an indication of unsuitability of a particular brand or type of filter for this analysis.

4. Calculation

A.2 WORKING PROCEDURE FOR LCK 414

NL

LCK 414 CZV Chemische zuurstof-verbruik

! *Let a.u.b. op de "Uitgave datum" (zie datatabel) en lees de "Opmerking!". Veiligheidsadvies en houdbaarheidsdatum op de verpakking.*

Principe

Oxideerbare stoffen reageren met een zwavelzure kaliumdichromaatoplossing in aanwezigheid van zilversulfaat als katalysator. Chloride wordt met kwiksulfaat gemaskeerd. Gemeten wordt de gele kleur van het Cr⁶⁺.

Toepassingsgebied

Afvalwater, procesanalyse, oppervlaktewater, koelwater

Stringen

De methode kan worden toegepast in monsters met een chloridegehalte van maximaal 1500 mg/l. Afvalwater kan in uitzonderingsgevallen stoffen bevatten waarvoor het oxidatievermogen van deze test niet voldoende is. In dergelijke gevallen adviseren wij, de test LCK 314 uit te voeren.

Een veel te grote hoeveelheid CZV kan ertoe leiden dat een resultaat wordt aangegeven dat binnen het meetbereik ligt. Het verdient in dit geval aanbeveling, te verdunnen een betrouwbaarheidscontrole uit te voeren.

De meetresultaten zijn via een plausibiliteitsonderzoek te controleren (verdunding en/of standaardadditie).

Opmerking!

In vergelijking met de klassieke CZV kuvettentest (CZV klassiek) is de hogere ontsluitingstemperatuur en korte ontsluitingstijd een belangrijk kenmerk van de HT-CZV.

In de praktijk wordt een vergelijking met de klassieke methode geadviseerd om er zeker van te zijn dat de HT-CZV voor de eigen monsters vergelijkbare resultaten oplevert.

GB

LCK 414 COD Chemical Oxygen Demand

! *Please check the "Edition Date" (see data table) and read the "Note". Safety advice and expiry date on package.*

Principe

Oxidizable substances react with sulphuric acid – potassium dichromate solution in the presence of silver sulphate as a catalyst. Chloride is masked by mercury sulphate. The reduction in the yellow coloration of Cr⁶⁺ is evaluated.

Range of Application

Waste water, process analysis, surface water, cooling water

Interferences

The method can be used for samples (or diluted samples) with chloride concentrations of up to 1500 mg/l. In exceptional cases some waste waters may contain substances for which the oxidizing capacity of this test is not sufficient. In such cases we recommend the use of test LCK 314.

A large excess of COD can cause result displays within the measuring range. It is advisable to carry out a plausibility check by making dilutions.

The measurement results must be subjected to plausibility checks (dilute and/or spike the sample).

Note

In contrast to the classic COD Cuvette Test (COD classic) the HT-COD is characterised by a higher digestion temperature and shorter digestion time.

Users are advised to carry out a comparison with the COD classic, in order to be sure that the results obtained from their own samples when using the HT-COD are comparable to the standard.

Datatabel / Data table

LP2W	02/1999
LCK 414 *) • F1 = 0 • F2 = -52.53 • K = 0	
CADAS 30/30S/50/50S	09/2001
LCK 414 *) • λ: 348 nm • Pro.: 8 • F1 = 45.18 • F2 = -45.51 • K = 0.001	
ISIS 6000/9000	09/2001
LCK 414 *) • λ: 360 nm • Pro.: 8 • F1 = 51.88 • F2 = -54.24 • K = 0	
CADAS 100 / LPG 158	02/1999
LCK 414 *) • λ: 348 nm • F = -45.33	
CADAS 100 / LPG 210	02/1999
LCK 414 *) • λ: 348 nm • F1 = -45.33	
CADAS 200	09/2001
LCK 414 *) • L1W1.(M.E1W1) • C1 = E1*F2-F3-L1*F1 • W1 = 348 nm • F1 = -44.91 • F2 = -45.19 • F3 = 0	

*) CZV klassiek / HT
COD classic / HT

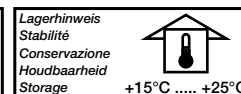
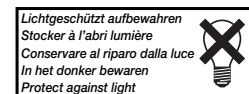

D

LCK 414 CSB Chemischer Sauerstoffbedarf

Bitte "Ausgabedatum" (s. Datentabelle) und "Hinweis" beachten. Sicherheitshinweise und Verfallsdatum auf der Packung.

Prinzip

Oxidierbare Stoffe reagieren mit schwefelsaurer Kaliumdichromatlösung in Gegenwart von Silbersulfat als Katalysator. Chlorid wird mit Quecksilbersulfat maskiert. Ausgewertet wird die Abnahme der Gelbfärbung des Cr⁶⁺.

Anwendungsbereich

Abwasser, Prozessanalytik, Oberflächenwasser, Kühlwasser

Störungen

Die Methode ist bis zu einem Chloridgehalt von 1500 mg/l in der Probe (oder verdünnten Probe) anwendbar. Abwässer können in Ausnahmefällen Inhaltsstoffe enthalten, für die das Oxidationsvermögen dieses Testes nicht ausreichend ist. Wir empfehlen dann die Anwendung des Küvetten-Testes LCK 314.

Ein hoher Überschuss an CSB kann zu Ergebnisanzeigen innerhalb des Messbereichs führen. Hier ist eine Plausibilitätskontrolle durch Verdünnen empfehlenswert.

Messergebnisse sind durch eine Plausibilitätskontrolle zu überprüfen (Verdünnung und/oder Aufstockung).

Hinweis

Im Vergleich zum klassischen CSB Küvetten-Test (CSB classic) zeichnet sich der HT-CSB durch eine höhere Aufschlusstemperatur und kürzere Aufschlusszeit aus. Für die Praxis wird der Vergleich mit dem CSB classic empfohlen, um sicherzustellen, dass der HT-CSB für die eigenen Proben vergleichbare Ergebnisse zur Norm liefert.

F

LCK 414 DCO Demande Chimique en Oxygène

Vérifier la date d'édition (voir table des données) et lire la "Remarque". Conseils de sécurité et date de péremption sur l'emballage.

Principe

Les substances oxydables réagissent avec le bichromate de potassium sulfurique, en présence de sulfate d'argent. Le chlorure est masqué avec du sulfate de mercure. La diminution de la coloration jaune du Cr⁶⁺ est mesurée par photométrie.

Domaine d'application

Eaux de rejet, analyses en mode contenu, eaux de surface, eaux de refroidissement

Perturbations

Cette méthode est applicable pour des échantillons (ou échantillon dilué) ayant une teneur en chlorure de 1500 mg/l max. Les eaux de rejet peuvent contenir exceptionnellement des substances pour lesquelles la capacité d'oxydation de ce test ne suffit pas. Il est alors conseillé d'appliquer le Test en Cuve LCK 314.

Malgré un excédent important de DCO, l'appareil peut tout de même afficher un résultat d'analyse compris dans la gamme de mesure. Pour éliminer une telle erreur, il est recommandé ici de vérifier le résultat obtenu en effectuant une nouvelle analyse après avoir dilué l'échantillon (contrôle de plausibilité).

Les résultats de mesures sont à vérifier par un contrôle de plausibilité (dilution et/ou addition).

Remarque

En comparaison avec les Tests en Cuve DCO classiques (DCO classiques), le HT-DCO offre une température de désagrégation plus élevée, ainsi qu'un temps de désagrégation réduit. Dans la pratique, la comparaison avec les DCO classiques est recommandée, afin de vous assurer que le HT-DCO fournit des résultats analogues dans les normes pour les différents échantillons.

I

LCK 414 COD Domanda Chimica di Ossigeno

Si prega di verificare la "Data di Edizione" (vedi tabella dati) e di leggere le "Note". Avvertenze e data di scadenza sulla confezione.

Principio

Reazione con soluzione di acido solforico e dicromato potassico più solfato di argento quale catalizzatore. I cloruri vengono mascherati col solfato di mercurio. La colorazione gialla del Cr⁶⁺ viene letta fotometricamente.

Applicazione

Acque di superficie, acque di scarico, analisi di processo, acque di raffreddamento

Interferenze

Il metodo è valido per un contenuto di cloruri nel campione (originale o diluito) fino a 1500 mg/l. In certi casi le acque da analizzare contengono sostanze inquinanti che superano la potenzialità ossidante del presente test. Si consiglia di impiegare il test LCK 314 (COD 15 – 150 mg/l). **Concentrazioni molto elevate di COD rischiano di dare risultati che rientrano nel campo di misura. Verificare diluendo il campione.**

I risultati sono da verificare con un controllo (diluizione e/o soluzione additiva).

Note

In rapporto all'analisi classica del COD, con i test in cuvetta Dr. Lange, l'HT-COD esegue l'ossidazione a una temperatura più alta e in tempi più rapidi. E'consigliato ogni tanto eseguire dei COD secondo la metodologia classica Dr. Lange (2h, 148°C) oltre che con l'HT-COD per accertarsi che i risultati siano confrontabili.

Datentabelle / Table des données / Tabella dati

LP2W	02/1999
LCK 414 *) • F1 = 0 • F2 = -52.53 • K = 0	
CADAS 30/30S/50/50S	09/2001
LCK 414 *) • λ: 348 nm • Pro.: 8 • F1 = 45.18 • F2 = -45.51 • K = 0.001	
ISIS 6000/9000	09/2001
LCK 414 *) • λ: 360 nm • Pro.: 8 • F1 = 51.88 • F2 = -54.24 • K = 0	
CADAS 100 / LPG 158	02/1999
LCK 414 *) • λ: 348 nm • F = -45.33	
CADAS 100 / LPG 210	02/1999
LCK 414 *) • λ: 348 nm • F1 = -45.33	
CADAS 200	09/2001
LCK 414 *) • L1W1.(M.E1W1) • C1 = E1*F2-F3-L1*F1 • W1 = 348 nm • F1 = -44.91 • F2 = -45.19 • F3 = 0	

*) CSB classic / HT
DCO classiques / HT
COD classica / HT

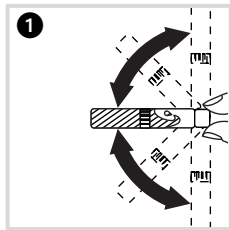

Bodensatz durch Schwenken in Schwebelage bringen.

Mélanger le contenu pour avoir une solution homogène.

Agitare delicatamente per sospendere il fondo.

Bezinking door schudden in suspensie brengen.

Bring the sediment into suspension by inverting a few times.

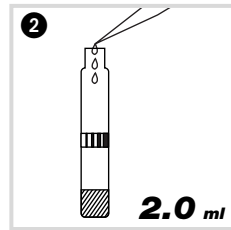

2.0 ml Probe **vorsichtig** pipettieren.

Pipetter **2.0 ml** d'échantillon **avec précaution**.

Pipettare **attentamente 2.0 ml** di campione.

2.0 ml monster **voorzichtig** pipetteren.

Carefully pipette **2.0 ml** sample.

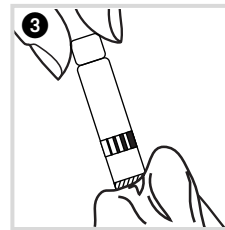

Küvette verschließen, von außen gut säubern.

Fermer la cuve et nettoyer l'extérieur de celle-ci.

Tappare la cuvetta, pulirla bene esternamente.

Kuvet sluiten, van buiten goed reinigen.

Close cuvette, thoroughly clean the outside.

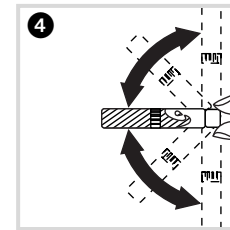

Schwenken.

Mélanger.

Mescolare.

Zwenken.

Invert.

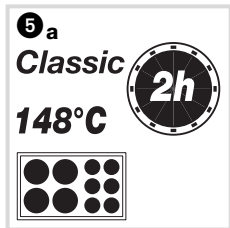

5 a
Classic
148°C
2h

Im Thermostaten erhitzen.

a) CSB classic: 2 Std bei **148°C**

b) HT 200 S: 15 min im Standardprogramm **HT**

Chauffer dans le thermostat.

a) DCO classique: 2 h à **148°C**

b) HT 200 S: 15 min avec le programme standard **HT**

Riscaldare nel termostato.

a) COD classica: 2 h a **148°C**

b) HT 200 S: 15 min nel programma standard **HT**

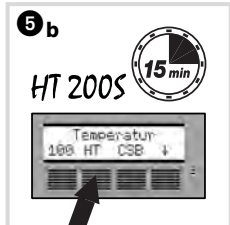

5 b
HT 200S
15 min

In het thermostaat verhitten.

a) CZV klassiek: 2 h bij **148°C**

b) HT 200 S: 15 min in standaard-programma **HT**

Heat in the thermostat.

a) COD classica: 2 h at **148°C**

b) HT 200 S: 15 min in standard program **HT** for **15 min**

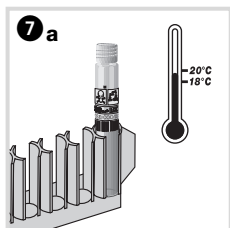

7 a

Auf Raumtemperatur abkühlen.

a) CSB classic: im Küvettenständer

b) HT 200 S: im Thermostaten

Laisser refroidir à température ambiante.

a) DCO classique: dans le support de cuve

b) HT 200 S: dans le thermostat

Fare raffreddare a temperatura ambiente.

a) COD classica: in un portacuvetta

b) HT 200 S: nel termostato

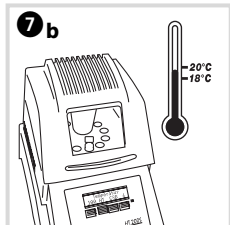

7 b

Laten afkoelen tot kamertemperatuur.

a) CZV klassiek: in kuvettenstandaard

b) HT 200 S: in thermostaat

Allow to cool to room temperature.

a) COD classica: in a cooling rack

b) HT 200 S: in the thermostat

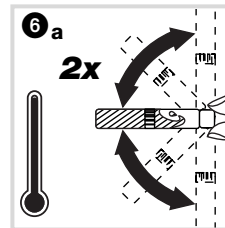

6 a
2x

Heiße Küvette entnehmen.

a) CSB classic: 2 x vorsichtig schwenken.

b) HT 200 S: nach Freigabe der Verriegelung **2 x vorsichtig** schwenken.

Sortir la cuve **chaude**.

a) DCO classique: Retourner **2 x avec précaution**.

b) HT 200 S: Après le déverrouillage, retourner **2 x avec précaution**.

Estrarre la cuvetta **calda**.

a) COD classica: Agitare **delicatamente 2 volte**.

b) HT 200 S: Dopo il rilascio del dispositivo di bloccaggio, agitare **delicatamente 2 volte**.

Het **hete** kuvet eruit nemen.

a) CZV klassiek: 2x voorzichtig zwenken.

b) HT 200 S: Na de vrijgeving van de afsluitbeveiliging, **2x voorzichtig** zwenken.

Remove the **hot** cuvette.

a) COD classica: Carefully invert **twice**.

b) HT 200 S: After the lock opens, **carefully** invert **twice**.

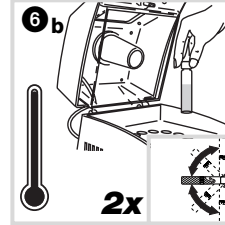

6 b
2x

CSB classic:

HT 200 S:

Küvette außen gut säubern und auswerten.

Feststoffteilchen müssen vor der Auswertung vollständig abgesetzt sein! Küvette außen gut säubern und auswerten.

DCO classique:

HT 200 S:

Bien nettoyer l'extérieur de la cuve et mesurer.

Les résidus doivent être complètement éliminés avant l'évaluation. Bien nettoyer l'extérieur de la cuve et mesurer.

COD classica:

HT 200 S:

Pulire bene la cuvetta esternamente e leggere.

Prima dell'analisi il sedimento deve essersi completamente depositato. Pulire bene la cuvetta esternamente e leggere.

CZV klassiek:

HT 200 S:

Kuvet van buiten goed reinigen en meten.

De nog aanwezige vaste stof moet voor de meting volledig bezonken zijn. Kuvet van buiten goed reinigen en meten.

COD classica:

HT 200 S:

Clean the outside of the cuvette and evaluate.

Sediment must be completely settled before evaluation is carried out. Clean the outside of the cuvette and evaluate.

	Nulllösung ① Solution zéro Il bianco Nulkuvet Zero-solution	Analysenküvette ② Cuve d'analyse Cuvetta d'analisi Analyse-kuvet Sample cuvette
 Barcode 1)	✓	✓

Auswertung / Evaluation / Lettura / Meting

1) LASA 50 / 100
XION 500
CADAS 30 / 50 / 30S / 50S / 200 Barcode
ISIS 9000
DR 2800 / DR 3800 / DR 3900 / DR 5000 / DR 6000

	Filter ① Filtre Filtro Filter Filter	Eprom ②	Test ③ - anwählen - choisir - selezionare - oproepen - select	Kontrollnr. ④ No. de contrôle No. di controllo Controlegetal Control no.	Nulllösung ⑤ Solution zéro Il bianco Nulkuvet Zero-solution	Analysenküvette ⑥ Cuve d'analyse Cuvetta d'analisi Analyse-kuvet Sample cuvette
LASA aqua	○ 414	_ : 42	CSB *) / HTCSB *) : ○ 414	--	✓	✓
LASA 1 / plus	330 nm	--	CSB *) / HTCSB *) LCK 414	2	✓	✓
LASA 10 / 20	--	_ : 46	CSB *) / HTCSB *) LCK 414	2	✓	✓

*) DCO / COD / CZV

	Filter ① Filtre Filtro Filter Filter	Test ② - anwählen - choisir - selezionare - oproepen - select	Faktor ③ Facteur Fattore Factor Factor	Kontrollnr. ④ No. de contrôle No. di controllo Controlegetal Control no.	Nulllösung ⑤ Solution zéro Il bianco Nulkuvet Zero-solution	Analysenküvette ⑥ Cuve d'analyse Cuvetta d'analisi Analyse-kuvet Sample cuvette
LP1W	340 nm / Nitrat 339	--	52.53	--	✓	✓
LP2W	340 nm / Nitrat 339	CSB *) LCK 414	--	6	✓	✓

*) DCO / COD / CZV

	Filter ① Filtre Filtro Filter Filter	Eprom ②	Mode ③	Test ④ - anwählen - choisir - selezionare - oproepen - select	Kontrollnr. ⑤ No. de contrôle No. di controllo Controlegetal Control no.	Nulllösung, blaue Taste ⑥ Solution zéro, touche bleue Il bianco, tasto blu Nulkuvet, blauwe toets Zero-solution, blue key	Analysenküvette, grüne Taste ⑦ Cuve d'analyse, touche verte Cuvetta d'analisi, tasto verde Analyse-kuvet, groene toets Sample cuvette, green key
CADAS 200 Basis	--	_ : 46	--	414	4	✓	✓
ISIS 6000	--	_ : 46	2)	414	4	✓	✓
LASA 30	340 nm	--	Dr. Lange	414	4	✓	✓

2) KÜVETTEN-TEST

2) TEST EN CUVE

2) CUVETTE-TEST

2) KUVETTENTEST

2) CUVETTE TEST

	Mode ①	Symbol ② Symbole Simbolo Symbol Symbol	Kontrollnr. ③ No. de contrôle No. di controllo Controlegetal Control no.	Nulllösung ④ Solution zéro Il bianco Nulkuvet Zero-solution	Analysenküvette ⑤ Cuve d'analyse Cuvetta d'analisi Analyse-kuvet Sample cuvette
CADAS 100 LPG158	TEST	414	--	✓	✓
CADAS 100 LPG210	TEST	414	5	✓	✓

A.3 WORKING PROCEDURE FOR LCK 614

NL

LCK 614 CZV Chemisch zuurstof verbruik

! *Let a.u.b. op de "Uitgave datum" (zie datatabel) en lees de "Opmerking!".
Veiligheidsadvies en houdbaarheidsdatum op de verpakking.*

Principe

Oxideerbare stoffen reageren met een zwavelzure kaliumdichromaatoplossing in aanwezigheid van zilversulfaat als katalysator. Chloride wordt met kwiksulfaat gemaskeerd. Gemeten wordt de gele kleur van het Cr⁶⁺.

Toepassingsgebied

Afvalwater, procesanalyse

Storingen

De methode kan worden toegepast in monsters met een chloridegehalte van maximaal 1500 mg/l.

Een veel te grote hoeveelheid CZV kan ertoe leiden dat een resultaat wordt aangegeven dat binnen het meetbereik ligt. Het verdient in dit geval aanbeveling, te verdunnen een betrouwbaarheidscontrole uit te voeren.

De meetresultaten zijn via een plausibiliteitsonderzoek te controleren (verdunding en/of standaard-additie).

Opmerking!

In vergelijking met de klassieke CZV kuvettentest (CZV klassiek) is de hogere ontsluitingstemperatuur en korte ontsluitingstijd een belangrijk kenmerk van de HT-CZV.

In de praktijk wordt een vergelijking met de klassieke methode geadviseerd om er zeker van te zijn dat de HT-CZV voor de eigen monsters vergelijkbare resultaten oplevert.

GB

LCK 614 COD Chemical Oxygen Demand

! *Please check the "Edition Date" (see data table) and read the "Note".
Safety advice and expiry date on package.*

Principe

Oxidizable substances react with sulphuric acid – potassium dichromate solution in the presence of silver sulphate as a catalyst. Chloride is masked by mercury sulphate. The reduction in the yellow coloration of Cr⁶⁺ is evaluated.

Range of Application

Waste water, process analysis

Interferences

The method can be used for samples (or diluted samples) with chloride concentrations of up to 1500 mg/l.

A large excess of COD can cause result displays within the measuring range. It is advisable to carry out a plausibility check by making dilutions.

The measurement results must be subjected to plausibility checks (dilute and/or spike the sample).

Note

In contrast to the classic COD Cuvette Test (COD classic) the HT-COD is characterised by a higher digestion temperature and shorter digestion time.

Users are advised to carry out a comparison with the COD classic, in order to be sure that the results obtained from their own samples when using the HT-COD are comparable to the standard.

Datatabel / Data table

LP2W	04/1998
LCK 614 *) • F1 = 0 • F2 = -262.3 • K = 395.8	
CADAS 30/30S/50/50S	09/2001
LCK 614 *) • λ: 448 nm • Pro.: 1 • F1 = 0 • F2 = -256.4 • K = 403.2	
ISIS 6000/9000	09/2001
LCK 614 *) • λ: 455 nm • Pro.: 1 • F1 = 0 • F2 = -266 • K = 401.9	
CADAS 100 / LPG 158	08/1999
LCK 614 *) • λ: 448 nm • F1 = -254 • F2 = 392.5	
CADAS 100 / LPG 210	08/1999
LCK 614 *) • λ: 448 nm • F1 = -254 • K = 392.5	

*) CZV klassiek / HT
COD classic / HT

D **LCK 614 CSB**
Chemischer Sauerstoffbedarf

Bitte "Ausgabedatum" (s. Datentabelle) und "Hinweis" beachten. Sicherheitshinweise und Verfallsdatum auf der Packung.

Prinzip

Oxidierbare Stoffe reagieren mit schwefelsaurer Kaliumdichromatlösung in Gegenwart von Silbersulfat als Katalysator. Chlorid wird mit Quecksilbersulfat maskiert. Ausgewertet wird die Abnahme der Gelbfärbung des Cr⁶⁺.

Anwendungsbereich

Abwasser, Prozessanalytik

Störungen

Die Methode ist bis zu einem Chloridgehalt von 1500 mg/l in der Probe (oder verdünnten Probe) anwendbar.

Ein hoher Überschuss an CSB kann zu Ergebnisanzeigen innerhalb des Messbereichs führen. Hier ist eine Plausibilitätskontrolle durch Verdünnen empfehlenswert.

Messergebnisse sind durch eine Plausibilitätskontrolle zu überprüfen (Verdünnung und/oder Aufstockung).

Hinweis

Im Vergleich zum klassischen CSB Küvetten-Test (CSB classic) zeichnet sich der HT-CSB durch eine höhere Aufschlusstemperatur und kürzere Aufschlusszeit aus. Für die Praxis wird der Vergleich mit dem CSB classic empfohlen, um sicherzustellen, dass der HT-CSB für die eigenen Proben vergleichbare Ergebnisse zur Norm liefert.

F **LCK 614 DCO**
Demande Chimique en Oxygène

Vérifier la date d'édition (voir table des données) et lire la "Remarque". Conseils de sécurité et date de péremption sur l'emballage.

Principe

Les substances oxydables réagissent avec le bichromate de potassium sulfurique, en présence de sulfate d'argent. Le chlorure est masqué avec du sulfate de mercure. La diminution de la coloration jaune du Cr⁶⁺ est mesurée par photométrie.

Domaine d'application

Eaux de rejet, analyses en mode contenu

Perturbations

Cette méthode est applicable pour des échantillons (ou échantillon dilué) ayant une teneur en chlorure de 1500 mg/l max.

Malgré un excédent important de DCO, l'appareil peut tout de même afficher un résultat d'analyse compris dans la gamme de mesure. Pour éliminer une telle erreur, il est recommandé ici de vérifier le résultat obtenu en effectuant une nouvelle analyse après avoir dilué l'échantillon (contrôle de plausibilité).

Les résultats de mesures sont à vérifier par un contrôle de plausibilité (dilution et/ou addition).

Remarque

En comparaison avec les Tests en Cuve DCO classiques (DCO classiques), le HT-DCO offre une température de désagrégation plus élevée, ainsi qu'un temps de désagrégation réduit. Dans la pratique, la comparaison avec les DCO classiques est recommandée, afin de vous assurer que le HT-DCO fournit des résultats analogues dans les normes pour les différents échantillons.

I **LCK 614 COD**
Domanda Chimica di Ossigeno

Si prega di verificare la "Data di Edizione" (vedi tabella dati) e di leggere le "Note". Avvertenze e data di scadenza sulla confezione.

Principio

Reazione con soluzione di acido solforico e dicromato potassico più solfato di argento quale catalizzatore. I cloruri vengono mascherati col solfato di mercurio. La colorazione gialla del Cr⁶⁺ viene letta fotometricamente.

Applicazione

Acque di superficie, acque di scarico

Interferenze

Il metodo è valido per un contenuto di cloruri nel campione (originale o diluito) fino a 1500 mg/l. **Concentrazioni molto elevate di COD rischiano di dare risultati che rientrano nel campo di misura. Verificare diluendo il campione.**

I risultati sono da verificare con un controllo (diluizione e/o soluzione additiva).

Note

In rapporto all'analisi classica del COD, con i test in cuvetta Dr. Lange, l'HT-COD esegue l'ossidazione a una temperatura più alta e in tempi più rapidi. E' consigliato ogni tanto eseguire dei COD secondo la metodologia classica Dr. Lange (2h, 148°C) oltre che con l'HT-COD per accertarsi che i risultati siano confrontabili.

Datentabelle / Table des données /

Tabella dati

LP2W	04/1998
LCK 614 *) • F1 = 0 • F2 = -262,3 • K = 395,8	
CADAS 30/30S/50/50S	09/2001
LCK 614 *) • λ: 448 nm • Pro.: 1 • F1 = 0 • F2 = -256,4 • K = 403,2	
ISIS 6000/9000	09/2001
LCK 614 *) • λ: 455 nm • Pro.: 1 • F1 = 0 • F2 = -266 • K = 401,9	
CADAS 100 / LPG 158	08/1999
LCK 614 *) • λ: 448 nm • F1 = -254 • F2 = 392,5	
CADAS 100 / LPG 210	08/1999
LCK 614 *) • λ: 448 nm • F1 = -254 • K = 392,5	

*) CSB classic / HT
DCO classiques / HT
COD classica / HT

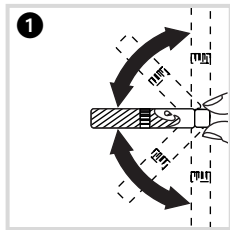

Bodensatz durch Schwenken in Schwebelage bringen.

Mélanger le contenu pour avoir une solution homogène.

Agitare delicatamente per sospendere il fondo.

Bezinking door schudden in suspensie brengen.

Bring the sediment into suspension by inverting a few times.

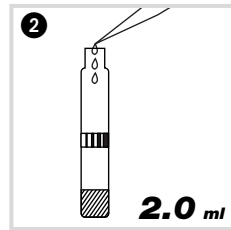

2.0 ml Probe **vorsichtig** pipettieren.

Pipetter **2.0 ml** d'échantillon **avec précaution**.

Pipettare **attentamente 2.0 ml** di campione.

2.0 ml monster **voorzichtig** pipetteren.

Carefully pipette **2.0 ml** sample.

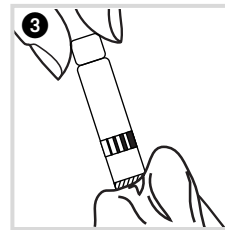

Küvette verschließen, von außen gut säubern.

Fermer la cuve et nettoyer l'extérieur de celle-ci.

Tappare la cuvetta, pulirla bene esternamente.

Kuvet sluiten, van buiten goed reinigen.

Close cuvette, thoroughly clean the outside.

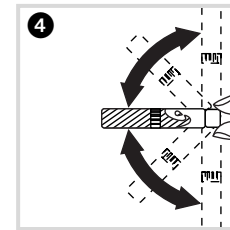

Schwenken.

Mélanger.

Mescolare.

Zwenken.

Invert.

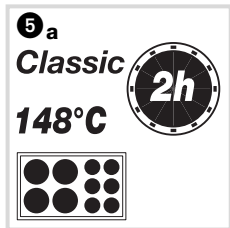

Im Thermostaten erhitzen.

a) CSB classic: 2 Std bei **148°C**

b) HT 200 S: 15 min im Standardprogramm **HT**

Chauffer dans le thermostat.

a) DCO classique: 2 h à **148°C**

b) HT 200 S: 15 min avec le programme standard **HT**

Riscaldare nel termostato.

a) COD classica: 2 h a **148°C**

b) HT 200 S: 15 min nel programma standard **HT**

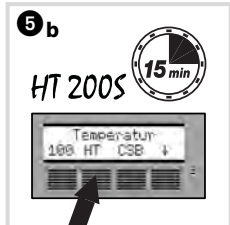

In het thermostaat verhitten.

a) CZV klassiek: 2 h bij **148°C**

b) HT 200 S: 15 min in standaard-programma **HT**

Heat in the thermostat.

a) COD classica: 2 h at **148°C**

b) HT 200 S: 15 min in standard program **HT** for **15 min**

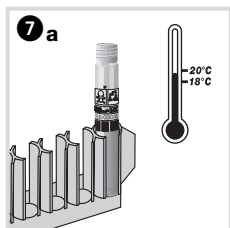

Auf Raumtemperatur abkühlen.

a) CSB classic: im Küvettenständer

b) HT 200 S: im Thermostaten

Laisser refroidir à température ambiante.

a) DCO classique: dans le support de cuve

b) HT 200 S: dans le thermostat

Lasciare raffreddare a temperatura ambiente.

a) COD classica: in un portacuvetta

b) HT 200 S: nel termostato

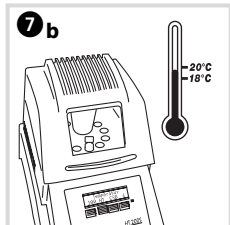

Laten afkoelen tot kamertemperatuur.

a) CZV klassiek: in kuvettenstandaard

b) HT 200 S: in thermostaat

Allow to cool to room temperature.

a) COD classica: in a cooling rack

b) HT 200 S: in the thermostat

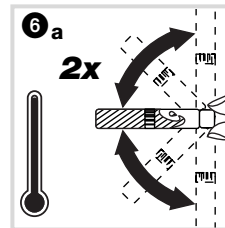

Heiße Küvette entnehmen.

a) CSB classic: 2 x vorsichtig schwenken.

b) HT 200 S: Nach Freigabe der Verriegelung **2 x vorsichtig** schwenken.

Sortir la cuve **chaude**.

a) DCO classique: Retourner **2 x avec précaution**.

b) HT 200 S: Après le déverrouillage, retourner **2 x avec précaution**.

Estrarre la cuvetta **calda**.

a) COD classica: Agitare **delicatamente 2 volte**.

b) HT 200 S: Dopo il rilascio del dispositivo di bloccaggio, agitare **delicatamente 2 volte**.

Het **hete** kuvet eruit nemen.

a) CZV klassiek: 2x voorzichtig zwenken.

b) HT 200 S: Na de vrijgeving van de afsluitbeveiliging, **2x voorzichtig** zwenken.

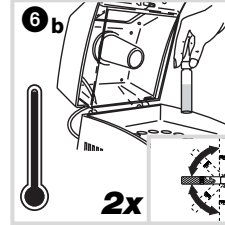

Remove the **hot** cuvette.

a) COD classica: Carefully invert **twice**.

b) HT 200 S: After the lock opens, **carefully** invert **twice**.

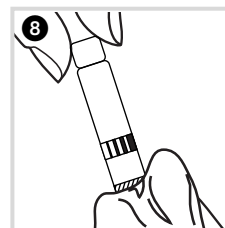

CSB classic:

HT 200 S:

Küvette außen gut säubern und auswerten.

Feststoffteilchen müssen vor der Auswertung vollständig abgesetzt sein! Küvette außen gut säubern und auswerten.

DCO classique:

HT 200 S:

Bien nettoyer l'extérieur de la cuve et mesurer.

Les résidus doivent être complètement éliminés avant l'évaluation. Bien nettoyer l'extérieur de la cuve et mesurer.

COD classica:

HT 200 S:

Pulire bene la cuvetta esternamente e leggere.

Prima dell'analisi il sedimento deve essersi completamente depositato. Pulire bene la cuvetta esternamente e leggere.

CZV klassiek:

HT 200 S:

Kuvet van buiten goed reinigen en meten.

De nog aanwezige vaste stof moet voor de meting volledig bezonken zijn. Kuvet van buiten goed reinigen en meten.

COD classica:

HT 200 S:

Clean the outside of the cuvette and evaluate.

Sediment must be completely settled before evaluation is carried out. Clean the outside of the cuvette and evaluate.

	Analysenküvette ① Cuve d'analyse Cuvetta d'analisi Analyse-kuvet Sample cuvette
 Barcode ¹⁾	✓

Auswertung / Evaluation / Lettura / Meting

¹⁾ LASA 50 / 100
XION 500
CADAS 30 / 50 / 30S / 50S / 200 Barcode
ISIS 9000
DR 2800 / DR 3800 / DR 3900 / DR 5000 / DR 6000

	Filter ① Filtre Filtro Filter Filter	Eprom ②	Test ③ - anwählen - choisir - selezionare - oproepen - select	Kontrollnr. ④ No. de contrôle No. di controllo Controlegetal Control no.	Analysenküvette ⑤ Cuve d'analyse Cuvetta d'analisi Analyse-kuvet Sample cuvette
LASA 1 / plus	440 nm	--	CSB *) / HTCSB *) LCK 614	1	✓
LASA 10 / 20	--	_ : 46	CSB *) / HTCSB *) LCK 614	1	✓

*) DCO / COD / CZV

	Filter ① Filtre Filtro Filter Filter	Test ② - anwählen - choisir - selezionare - oproepen - select	Faktor ③ Facteur Fattore Factor Factor	Kontrollnr. ④ No. de contrôle No. di controllo Controlegetal Control no.	Nulllösung ⑤ Solution zéro Bianco Nulkuvet Zero-solution	Leerwert (dest. Wasser) ⑥ Valeur à blanc (l'eau dist.) Bianco (acqua dist.) Blanko (gedest. water) Blank-value (dist. water)	Analysenküvette ⑦ Cuve d'analyse Cuvetta d'analisi Analyse-kuvet Sample cuvette
LP1W	440 nm	--	262.3	--	LYW 614	--	✓
LP2W	440 nm	CSB *) LCK 614	--	2	--	LCW 919	✓

*) DCO / COD / CZV

	Filter ① Filtre Filtro Filter Filter	Eprom ②	Mode ③	Test ④ - anwählen - choisir - selezionare - oproepen - select	Kontrollnr. ⑤ No. de contrôle No. di controllo Controlegetal Control no.	Analysenküvette, grüne Taste ⑥ Cuve d'analyse, touche verte Cuvetta d'analisi, tasto verde Analyse-kuvet, groene toets Sample cuvette, green key
CADAS 200 Basis	--	_ : 46	--	614	2	✓
ISIS 6000	--	_ : 46	²⁾	614	2	✓
LASA 30	440 nm	--	Dr. Lange	614	2	✓

²⁾ KÜVETTEN-TEST

²⁾ TEST EN CUVE

²⁾ CUVETTE-TEST

²⁾ KUVETTENTEST

²⁾ CUVETTE TEST

	Mode ①	Symbol ② Symbole Simbolo Symbol Symbol	Kontrollnr. ③ No. de contrôle No. di controllo Controlegetal Control no.	Leerwert (dest. Wasser) ④ Valeur à blanc (l'eau dist.) Bianco (acqua dist.) Blanko (gedest. water) Blank-value (dist. water)	Analysenküvette ⑤ Cuve d'analyse Cuvetta d'analisi Analyse-kuvet Sample cuvette
CADAS 100 LPG158	TEST	\$ 614	--	LCW 919	✓
CADAS 100 LPG210	TEST	614	6	LCW 919	✓

A.4 WORKING PROCEDURE FOR LCK 349

ACHTUNG / ATTENTION / ATTENZIONE / LET OP / NB

(DE) Wichtiger Hinweis für die Auswertung!

Ohne Hydrolyse wird nur das (gelöste) **ortho-Phosphat** erfasst.

Das Ergebnis Ihrer ortho-Phosphat-Bestimmung können Sie angeben als: mg/l PO₄-P (z.B. für die Prozessanalyse), mg/l PO₄ (z.B. für Trink- und Kesselwasseruntersuchungen), mg/l P₂O₅ (z.B. für Bodenuntersuchungen).

Mit Hydrolyse wird grundsätzlich der **Gesamt-Phosphor** (Gesamt-P, P_{gesamt}) erfasst.

Das Ergebnis Ihrer Gesamt-Phosphor-Bestimmung können Sie angeben als:

mg/l P_{ges} = Displayanzeige mg/l PO₄-P (z.B. für die Grenzwertüberwachung im Abwasser), mg/l PO₄ (z.B. für Trink- und Kesselwasseruntersuchungen), mg/l P₂O₅ (z.B. für Bodenuntersuchungen).

(FR) Remarque importante pour l'interprétation des résultats!

Sans hydrolyse, seul l'**orthophosphate** (dissous) est détecté.

Le résultat de votre détermination de l'orthophosphate peut s'exprimer en: mg/l PO₄-P (p. ex. pour les analyses en mode contenu), mg/l PO₄ (p. ex. pour les analyses d'eau potable et d'eau de chaudière), mg/l P₂O₅ (p. ex. pour les analyses de sols).

Avec hydrolyse, c'est principalement le **phosphore total** (P total, P_{total}) qui est détecté.

Le résultat de votre détermination du phosphore total peut s'exprimer en: **mg/l P_{total} = affichage mg/l PO₄-P** (p. ex. pour le contrôle des valeurs limites dans les eaux de rejet), mg/l PO₄ (p. ex. pour les analyses d'eau potable et d'eau de chaudière), mg/l P₂O₅ (par exemple pour les analyses de sols).

(IT) Indicazioni importanti per l'analisi!

Senza idrolisi vengono determinati solo gli **ortofosfati** (disciolti).

Il risultato della determinazione di ortofosfato può essere espresso come: mg/l PO₄-P (per es. per analisi di processo), mg/l PO₄ (per es. per acqua potabile, acqua di caldaia), mg/l P₂O₅ (per es. per analisi di terreni).

Con idrolisi viene determinato essenzialmente il **fosforo totale**.

Il risultato della determinazione di fosforo totale può essere espresso come: **mg/l P_{tot} = display mg/l PO₄-P** (per es. per determinazione dei valori soglia nelle acque di scarico), mg/l PO₄ (per es. per acqua potabile, acqua di caldaia), mg/l P₂O₅ (per es. per analisi di terreni).

(NL) Belangrijke richtlijn voor de uitwaardering!

Zonder hydrolyse wordt alleen het (opgeloste) **orthofosfaat** bepaald.

Het resultaat van uw orthofosfaat bepaling kan u weergeven als: mg/l PO₄-P (b.v. voor procesanalyse), mg/l PO₄ (b.v. voor drinkwater- en ketelwateronderzoek), mg/l P₂O₅ (b.v. voor grondonderzoek).

Met hydrolyse wordt in principe het **totaal fosfor** (Totaal P, P_{totaal}) bepaald.

Het resultaat van uw totaal fosfor bepaling kan u weergeven als: **mg/l P_{tot} = Display mg/l PO₄-P** (b.v. voor grensbewaking van het afvalwater), mg/l PO₄ (b.v. voor drinkwater- en ketelwateronderzoek), mg/l P₂O₅ (b.v. voor grondonderzoek).

(EN) Important information for the evaluation!

Without hydrolysis, only the (dissolved) **orthophosphate** is measured.

The result of the orthophosphate measurement can be expressed as: mg/l PO₄-P (e.g. for process analysis), mg/l PO₄ (e.g. for analyses of drinking water or boiler water), mg/l P₂O₅ (e.g. for soils analyses)

With hydrolysis, all of the **phosphorus** (Total-P, P_{total}) is measured.

The result of the total phosphorus measurement can be expressed as: **mg/l P_{tot} = Display mg/l PO₄-P** (e.g. for monitoring threshold values in waste water), mg/l PO₄ (e.g. for analyses of drinking water or boiler water), mg/l P₂O₅ (e.g. for soils analyses).

NL

LCK 349

Fosfor totaal / Fosfaat ortho

Let a.u.b. op de "Uitgave datum" (zie datatabel) en lees de "Opmerking!".
Veiligheidsadvies en houdbaarheidsdatum op de verpakking.

Principe

Fosfaat-ionen reageren in zure oplossing met molybdaat- en antimoon-ionen; dit geeft een antimonylfosformolybdaat-complex, dat door ascorbinezuur wordt gereduceerd tot fosformolybdeenblauw.

Toepassingsgebied

Afvalwater, drinkwater, ketelwater, oppervlaktewater, procesanalyse

Stringen

De, in **T1** genoemde ionen, zijn tot aan de aangegeven concentratie afzonderlijk onderzocht en storen niet. De invloed van het cumulatief effect en invloed van andere ionen is niet door ons onderzocht.

De meetresultaten zijn via een plausibiliteitsonderzoek te controleren (verdunding en/of standaard-additie).

Opheffen van stringen

Bij aanwezigheid van fosfonzuren moet de verwarmingstijd van de hydrolyse (zie de werkwijze voor de bepaling van fosfor totaal) worden verlengd tot **2 uur** bij een temperatuur van **100°C** in de thermostaat, teneinde te voorkomen dat te lage resultaten worden gevonden.

pH-waarde monster 2–10

Temperaturen monster/reagentia 15–25 °C

Afwijkende temperaturen beïnvloeden de nauwkeurigheid van het resultaat.

Opmerking!

Het resultaat is betrouwbaarder als de kuvet na de ontsluiting wordt gezwenkt.

EN

LCK 349

Phosphorus total / Phosphate ortho

Please check the "Edition Date" (see data table) and read the "Note".
Safety advice and expiry date on package.

Principle

Phosphate ions react with molybdate and antimony ions in an acidic solution to form an antimonyl phosphomolybdate complex, which is reduced by ascorbic acid to phosphomolybdenum blue.

Range of Application

Waste water, drinking water, boiler water, surface water, process analysis

Interferences

The ions listed in **T1** have been individually checked up to the given concentrations and do not cause interference. We have not determined cumulative effects and the influence of other ions.

The measurement results must be subjected to plausibility checks (dilute and/or spike the sample).

Removal of Interferences

If phosphonic acids are present the time for hydrolysis in the thermostat must be increased to **2 h** at **100°C** in order to prevent low-bias results (see procedure for the determination of total phosphorus).

pH sample 2–10

Temperature sample/reagents 15–25 °C

In case of not working at the right recommended temperature an incorrect result may be obtained.

Note

Inverting the cuvette after hydrolysis improves the reliability of the result.

T1		
5000 mg/l:	SO ₄ ²⁻	50 mg/l: Co ²⁺ , Fe ²⁺ , Fe ³⁺ , Zn ²⁺ , Cu ²⁺ , Ni ²⁺ , I ⁻ , NO ₂ ⁻ , Cd ²⁺ , NH ₄ ⁺ , Mn ²⁺ , Al ³⁺ , Co ₃ ²⁻ , SiO ₂
2000 mg/l:	Cl ⁻	
1000 mg/l:	K ⁺ , Na ⁺	
500 mg/l:	NO ₃ ⁻	5 mg/l: Sn ⁴⁺ , Hg ²⁺
250 mg/l:	Ca ²⁺	2.5 mg/l: Ag ⁺ , Pb ²⁺
100 mg/l:	Mg ²⁺	1 mg/l: Cr ³⁺
		0.5 mg/l: Cr ⁶⁺

**Datentabelle · Table des données ·
Tabella dati · Datatabel · Data table**

LP2W	12/2007
PO ₄ -P • λ: 890 nm • Pro.: 1 • F1 = 0 • F2 = 2.00 • K = -0.103	
PO ₄ • λ: 890 nm • Pro.: 1 • F1 = 0 • F2 = 6.15 • K = -0.318	
CADAS 30/30S/50/50S	12/2007
PO ₄ -P • λ: 890 nm • Pro.: 1 • F1 = 0 • F2 = 1.412 • K = -0.179	
PO ₄ • λ: 890 nm • Pro.: 1 • F1 = 0 • F2 = 4.327 • K = -0.540	
P ₂ O ₅ • λ: 890 nm • Pro.: 1 • F1 = 0 • F2 = 3.234 • K = -0.409	
ISIS 6000/9000	12/2007
PO ₄ -P • λ: 695 nm • Pro.: 1 • F1 = 0 • F2 = 2.024 • K = -0.203	
PO ₄ • λ: 695 nm • Pro.: 1 • F1 = 0 • F2 = 6.205 • K = -0.612	
P ₂ O ₅ • λ: 695 nm • Pro.: 1 • F1 = 0 • F2 = 4.637 • K = -0.461	
CADAS 100/LPG 158	12/2007
PO ₄ -P • λ: 850 nm • F1 = 1.607 • F2 = -0.088	
PO ₄ • λ: 850 nm • F1 = 4.925 • F2 = -0.270	
P ₂ O ₅ • λ: 850 nm • F1 = 3.681 • F2 = -0.209	
CADAS 100/LPG 210	12/2007
PO ₄ -P • λ: 850 nm • F1 = 1.607 • F2 = -0.088	
PO ₄ • λ: 850 nm • F1 = 4.925 • F2 = -0.270	
P ₂ O ₅ • λ: 850 nm • F1 = 3.681 • F2 = -0.209	
CADAS 200	12/2007
PO ₄ -P • E1W1 • C1 = E1•F1•F2 • W1 = 850 nm • F1 = 1.615 • F2 = 0.177	
PO ₄ • E1W1 • C1 = E1•F1•F2 • W1 = 850 nm • F1 = 4.952 • F2 = 0.548	
P ₂ O ₅ • E1W1 • C1 = E1•F1•F2 • W1 = 850 nm • F1 = 3.709 • F2 = 0.405	
DR2800 / DR3800	12/2007
PO ₄ -P • λ: 890 nm • F1 = 1.415 • F2 = 0.1814	
DR5000	12/2007
PO ₄ -P • λ: 850 nm • F1 = 1.631 • F2 = 0.180	

DE LCK 349
Phosphor gesamt / Phosphat ortho

Bitte "Ausgabedatum" (s. Datentabelle) und "Hinweis" beachten.
Sicherheitshinweise und Verfallsdatum auf der Packung.

Prinzip
Phosphationen reagieren in saurer Lösung mit Molybdat- und Antimonionen zu einem Antimonylphosphormolybdat-Komplex, der durch Ascorbinsäure zu Phosphormolybdänblau reduziert wird.

Anwendungsbereich
Oberflächen-, Trink-, Kessel-, Abwasser, Prozessanalytik

Störungen
Die in **T1** aufgeführten Ionen wurden bis zu den angegebenen Konzentrationen einzeln überprüft und stören nicht. Die summarische Wirkung sowie der Einfluss weiterer Ionen wurden von uns nicht ermittelt.

Messergebnisse sind durch eine Plausibilitätskontrolle zu überprüfen (Verdünnung und/oder Aufstockung).

Beseitigung von Störungen
Bei Anwesenheit von Phosphonsäuren muss die Temperierungszeit der Hydrolyse (siehe Arbeitsgang zur Bestimmung von Gesamt-Phosphor) auf **2 h** bei **100°C** im Thermostaten erhöht werden, um Minderbefunde zu vermeiden.

pH-Wert Probe 2–10
Temperatur Probe/Reagenzien 15–25 °C
Abweichende Temperaturen beeinflussen die Ergebnisrichtigkeit.

Hinweis
Das Schwenken der Küvette nach der Hydrolyse erhöht die Ergebnissicherheit.

FR LCK 349
Phosphore total / Phosphate ortho

Vérifier la date d'édition (voir table des données) et lire la "Remarque".
Conseils de sécurité et date de péremption sur l'emballage.

Principe
Les ions phosphate réagissent en solution acide avec les ions molybdate et antimoine pour donner un complexe de phosphore molybdate d'antimoine. Celui-ci est réduit par l'acide ascorbique en bleu de phosphore molybdène.

Domaine d'application
Eaux de rejet, eaux potables, eaux de chaudière, eaux de surface, analyses en mode continu

Perturbations
Les ions mentionnés dans **T1** ont été vérifiés séparément, ils n'interferent pas jusqu'aux concentrations indiquées. Nous n'avons cependant pas étudié l'effet cumulatif et l'influence d'ions supplémentaires.

Les résultats de mesures sont à vérifier par un contrôle de plausibilité (dilution et/ou addition).

Solutions aux perturbations
En présence d'acides phosphoniques, le temps d'équilibrage de la température de l'hydrolyse (voir du mode opératoire pour la détermination du phosphore total) devra être augmenté à **2 h** à **100°C** dans le thermostat pour éviter des résultats trop faibles.

pH échantillon 2–10
Température échantillon/réactifs 15–25 °C
Des températures différentes influencent l'exactitude des résultats.

Remarque
Mélanger la cuve après hydrolyse améliore sensiblement la qualité du résultat.

IT LCK 349
Fosforo totali / Fosfati orto

Si prega di verificare la "Data di Edizione" (vedi tabella dati) e di leggere le "Note".
Avvertenze e data di scadenza sulla confezione.

Principio
Ioni fosfato formano in soluzione acida con ioni molibdato e antimonio un complesso antimoniilfosfomolibdato che con acido ascorbico si riduce in blu di fosfomolibdato.

Applicazione
Acqua potabile, acque di superficie, acque di scarico, acqua di caldaia, analisi di processo

Interferenze
Gli ioni elencati in **T1** sono stati verificati singolarmente fino alle concentrazioni specificate e non causano interferenze. Non sono stati verificati eventuali effetti cumulativi e l'influenza di altri ioni.

I risultati sono da verificare con un controllo (diluizione e/o soluzione additiva).

Eliminazione interferenze
Se sono presenti acidi fosfonici, la durata dell'idrolisi nel termostato deve essere di **2 ore**, sempre a **100°C**, in modo da prevenire sottostime (vedere la metodica di determinazione del fosforo totale).

pH campione 2–10
Temperatura campione/reagenti 15–25 °C
Variazioni della temperatura influenzano la correttezza del valore misurato.

Note
Invertendo la cuvetta dopo l'idrolisi si migliora l'affidabilità del risultato.

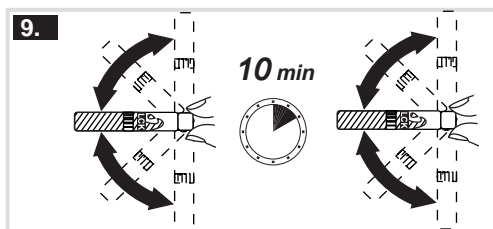
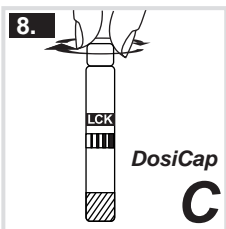
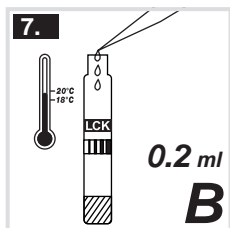
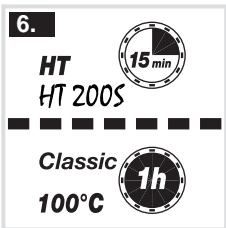
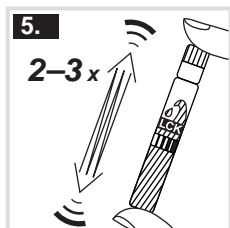
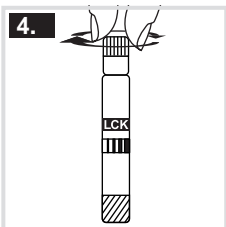
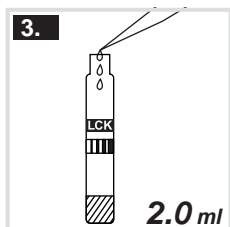
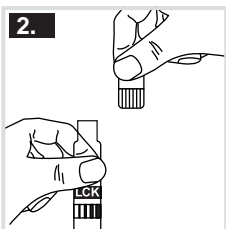
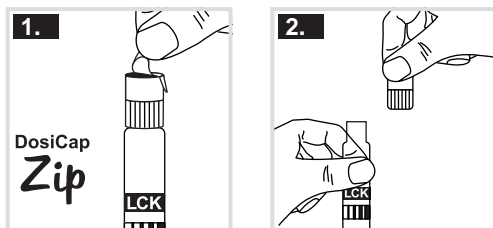

1. – 9.
Gesamt-Phosphor
Phosphore total
Fosforo totali
Fosfor totaal
Total Phosphorus

3., 7. – 9.
Ortho-Phosphat
Orthophosphate
Ortofosfati
Orthofosfaat
Orthophosphate

IT

1. Rimuovere **con attenzione** il foglio di alluminio.
2. Svitare il **DosiCap Zip**.
3. Pipettare **2.0 ml** di campione.
4. Avvitare il **DosiCap Zip**; scanalatura esterna verso l'alto.
5. Agitare energicamente.
6. Riscaldare nel termostato.
HT 200 S: 15 min nel programma standard **HT Termostato: 60 min** a **100°C**
7. Pipettare nella cuvetta raffreddata: **0.2 ml** di reattivo **B** (LCK 349 B). Dopo aver prelevato il reattivo B, richiudere **immediatamente**.
8. Avvitare un **DosiCap C (capsula grigia)** (LCK 349 C).
9. Mescolare capovolgendo la cuvetta più volte. Dopo **10 min** mescolare nuovamente, pulire bene la cuvetta esternamente e leggere.

DE

1. Siegelfolie von dem aufgeschraubten **DosiCap® Zip** **vorsichtig** abziehen.
2. **DosiCap® Zip** abschrauben.
3. **2.0 ml** Probe pipettieren.
4. **DosiCap® Zip** aufschrauben; Riffelung oben.
5. Kräftig schütteln.
6. Im Thermostaten erhitzen.
HT 200 S: 15 min im Standardprogramm **HT Termostat: 60 min** bei **100°C**
7. In erkaltete Küvette pipettieren: **0.2 ml** Reagenz **B** (LCK 349 B). Reagenz B nach Gebrauch **sofort** verschließen.
8. **Graues DosiCap® C** (LCK 349 C) auf die Küvette schrauben.
9. Küvette schwenken, dabei mehrfach auf den Kopf drehen. Nach **10 min** Küvette noch einmal schwenken, außen gut säubern und auswerten.

NL

1. Afdekfolie **voorzichtig** verwijderen.
2. **DosiCap Zip** afschroeven.
3. **2.0 ml** monster pipetteren.
4. **DosiCap Zip** opschroeven; geribbelde zijde naar boven.
5. Krachtig schudden.
6. In het thermostaat verhitten.
HT 200 S: 15 min in standaard-programma **HT Thermostaat: 60 min** bij **100°C**
7. In afgekoelde kuvet pipetteren: **0.2 ml** reagens **B** (LCK 349 B). De reagens B-fles na gebruik **onmiddelijk** dicht draaien.
8. Een **grijze DosiCap C** (LCK 349 C) op het kuvet schroeven.
9. Kuvet zwenken en daarbij meerdere malen op zijn kop houden. Na **10 min** het kuvet opnieuw zwenken, van buiten goed reinigen en meten.

FR

1. Enlevez **délicatement** la feuille de protection du **DosiCap Zip** détachable.
2. Dévissez le **DosiCap Zip**.
3. Pipetter **2.0 ml** d'échantillon.
4. Vissez le **DosiCap Zip**; dirigeant le cannelage vers le haut.
5. Secouer énergiquement.
6. Chauffer dans le thermostat.
HT 200 S: 15 min avec le programme standard **HT Thermostat: 60 min** à **100°C**
7. Pipetter dans la cuve une fois refroidie: **0.2 ml** de réactif **B** (LCK 349 B). Fermer **immédiatement** le réactif B après emploi.
8. Visser un **DosiCap C** (LCK 349 C) **gris** sur la cuve.
9. Mélanger le contenu de la cuve en la retournant plusieurs fois de suite. Attendre **10 min**, mélanger de nouveau, bien nettoyer l'extérieur de la cuve et mesurer.

EN

1. **Carefully** remove the foil from the screwed-on **DosiCap Zip**.
2. Unscrew the **DosiCap Zip**.
3. Pipette **2.0 ml** sample.
4. Screw the **DosiCap Zip** back; fluting at the top.
5. Shake firmly.
6. Heat in the thermostat.
HT 200 S: in standard program HT for 15 min Thermostat: 60 min at **100°C**
7. Pipette into the cooled cuvette: **0.2 ml** Reagent **B** (LCK 349 B). Close Reagent B **immediately** after use.
8. Screw a **grey DosiCap C** (LCK 349 C) onto the cuvette.
9. Invert a few times. After **10 min** invert a few times more, thoroughly clean the outside of the cuvette and evaluate.



DE: Für folgende Barcode-Geräte erfolgt nach Einsetzen der Analysenküvette eine automatische Auswertung:

FR: Si vous utilisez un des instruments avec codes à barres suivants, une évaluation automatique est réalisée après l'insertion de la cuve d'analyse :

IT: Se si utilizza uno qualsiasi dei seguenti strumenti con codice a barre, dopo aver inserito la cuvetta d'analisi viene automaticamente visualizzato il risultato della misura:

NL: Wanneer een van de volgende barcode instrumenten worden gebruikt, wordt een automatische uitwaardering uitgevoerd zodra de analyse-kuvet geplaatst wordt:

EN: If any of the following barcode instruments is used, an automatic evaluation is carried out after the sample cuvette is inserted:

LASA 50 / 100, XION 500, CADAS 30 / 50 / 30S / 50S / 200 Barcode, ISIS 9000, DR 2800 / DR 3800 / DR 3900 / DR 5000 / DR 6000

DE	FR	IT	NL	EN		LASA aqua	LASA 1 / plus	LASA 10	LASA 10 / 20	CADAS 200 Basis	ISIS 6000	LASA 30	LP1W	LP2W	CADAS 100 LPG158	CADAS 100 LPG210				
Filter	Filtre	Filtro	Filter	Filter	↓	○ 349 P / ○ 349	690 nm	–	–	–	–	800 nm	800 nm	800 nm	–	–				
Eprom	Eprom	Eprom	Eprom	Eprom	2	_ : 46	–	11 : 46 / 99 : 46	98 : 46 / _ : 46	_ : 46	_ : 46	–	–	–	–	–				
Mode	Mode	Mode	Mode	Mode	3	–	–	–	–	–	KÜVETTEN- TEST ¹⁾	Dr. Lange	–	–	TEST	TEST				
Symbol	Symbole	Simbolo	Symbool	Symbol	4	–	–	–	–	–	–	–	–	–	PO ₄ -P: \$ 349 E PO ₄ : \$ 349 P ₂ O ₅ : \$ 349 P	PO ₄ -P: 349 E PO ₄ : 349 P ₂ O ₅ : 349 P				
Test anwählen	Test choisir	Test selezionare	Test oproepen	Test select	5	PO ₄ -P: ○ 349 P PO ₄ : ○ 349	PO ₄ -P/ PO ₄ LCK 349	PO ₄ -P/ PO ₄ LCK 349	PO ₄ -P/ PO ₄ LCK 349	349	349	349	–	PO ₄ -P/ PO ₄ LCK 349	–	–				
Faktor	Facteur	Fattore	Factor	Factor	6	–	–	–	–	–	–	–	PO ₄ -P: 2.00 PO ₄ : 6.15 P ₂ O ₅ : 4.60	–	–	–				
Kontrollnr.	No. de contrôle	No. di controllo	Controlegetal	Control no.	7	–	2	2	2	6	6	6	–	6	–	6				
Nulllösung	Solution zéro	Bianco	Nulkuvet	Zero-solution	8a	–	–	–	–	–	–	–	LCW 918	NULL ▲	–	–				
Leerwert (dest. Wasser)	Valeur à blanc (l'eau dist.)	Bianco (acqua dist.)	Blanko (gedest. water)	Blank-value (dist. water)	8b	–	–	–	–	–	–	–	–	LCW 919	NULL ▲	LCW 919	NULL ▲	LCW 919	NULL ▲	
Analysenküvette	Cuve d'analyse	Cuvetta d'analisi	Analyse-kuvet	Sample cuvette	9	✓	✓	✓	✓	–	–	–	✓	ERGBNIS ▲	✓	ERGBNIS ▲	✓	MESS ▲	✓	MESS ▲
Analysenküvette, grüne Taste	Cuve d'analyse, touche verte	Cuvetta d'analisi, tasto verde	Analyse-kuvet, groene toets	Sample cuvette, green key	10	–	–	–	–	✓	✓	✓	–	–	–	–	–			
☰ Vom Ergebnis abziehen:	☰ Soustraire au résultat:	☰ Sottrarre dal risultato:	☰ Van het resultaat aftrekken:	☰ Subtract from the result:	11	PO ₄ -P: 0.08 mg/l PO ₄ : 0.263 mg/l	PO ₄ -P: 0.08 mg/l PO ₄ : 0.263 mg/l	PO ₄ -P: 0.08 mg/l PO ₄ : 0.263 mg/l	PO ₄ -P: 0.09 mg/l PO ₄ : 0.275 mg/l	–	–	–	PO ₄ -P: 0.102 mg/l PO ₄ : 0.317 mg/l P ₂ O ₅ : 0.237 mg/l	–	–	–				

FR: ¹⁾ TEST EN CUVE

IT: ¹⁾ CUVETTE-TEST

NL: ¹⁾ KUVETTENTEST

EN: ¹⁾ CUVETTE TEST

A.5 SALSNES FILTERS BENCH SCALE FILTER TEST APPARATUS

Salsnes Filter Screening Test Procedure

1. Prepare a custom Salsnes Filter Screening Test form for the present test, with the sieve cloth openings expected to be most suitable for the type of wastewater to be tested.
2. Use standard Salsnes Filter bench-scale test equipment and sieve cloths with proper sieve openings. Make sure sieve cloths are clean.
3. Collect a batch of the wastewater to be tested. The batch should be sufficiently large to run all the planned tests. Normally this will take a batch of 50 to 100 L (13 to 26 gallons) of medium strength municipal wastewater for a full size test. Keep the wastewater in a large storage tank and stir vigorously (paddle oar in figure-8 pattern) prior to any time wastewater is taken out of the tank for analysis or to be put through the test apparatus.
4. Take out a sample of untreated wastewater from the tank and label it according to the Sample ID in the Salsnes Filter Screening Test form.
5. Put a sieve cloth in the test apparatus. Keep a sample bottle under the apparatus. Measure out a 1 L (1000 mL) sample from the storage tank and pour into the test apparatus. Open valve completely and collect all of the filtered sample in the sample bottle. Label sample bottle according to the Sample ID in the Salsnes Filter Screening Test form.
6. Measure out more wastewater from the storage tank and add to test apparatus. Partially open the valve to let wastewater filter through the sieve cloth at a speed where the water level drops 3 - 4 cm/sec. This will start to build a filter mat on the sieve cloth.
7. When a filter mat has been established, close valve completely and fill wastewater to 300 mm mark. Stand by with sample bottle and stop watch. Simultaneously start the stop watch and open the valve completely. Measure the time it takes for the water level to drop from the 300 mm mark to the 200 mm mark. Sample the filtered water between the 300 mm mark and the 200 mm mark, which means that the sample bottle must be removed exactly when the water level hits the 200 mm mark. Label sample bottle according to the Sample ID in the Salsnes Filter Screening Test form. Fill in the Salsnes Filter Screening Test form with the total amount of wastewater (including the first liter) added to the test apparatus and the time it took for the water level to drop from the 300 mm mark to the 200 mm mark.
8. To repeat measurement with a thicker filter mat, repeat steps 6 and 7. Normally two or three measurements will be sufficient. We are typically looking for filtration times of 1 to 15 sec from the 300 mm mark to the 200 mm mark.
9. Continue testing with the next mesh size, by repeating steps 5, 6, 7 and 8.
10. When testing with all mesh sizes is completed, take out a new sample of untreated wastewater from the storage tank and label it according to the Sample ID in the Salsnes Filter Screening Test form. If the concentration of SS is higher than for the sample taken in step 4, stirring of the storage tank has been inadequate.

Salsnes Screening Test

Plant:

Type of wastewater:

Location of sampling point:

Date:

Time:

Water temperature:

°C

Sample ID	Sieve cloth (μ)	Sample type	Total water volume (liters)	Time from 30 – 20 cm (sec)	SS (mg/L)	Total COD (mg/L)	Filtered COD (mg/L)	Comments (Vol filtered and time taken)
1	None	Un-treated 1	NA	NA				
2	500	First liter	1,0	NA			NA	
3	500	W/ filter mat					NA	
4	500	W/ filter mat					NA	
5	500	W/ filter mat					NA	
6	350	First liter	1,0	NA			NA	
7	350	W/ filter mat					NA	
8	350	W/ filter mat					NA	
9	350	W/ filter mat					NA	
10	250	First liter	1,0	NA			NA	
11	250	W/ filter mat					NA	
12	250	W/ filter mat					NA	
13	250	W/ filter mat					NA	
14	210	First liter	1,0	NA			NA	
15	210	W/ filter mat					NA	
16	210	W/ filter mat					NA	
17	210	W/ filter mat					NA	
18	150	First liter	1,0	NA			NA	
19	150	W/ filter mat					NA	
20	150	W/ filter mat					NA	
21	150	W/ filter mat					NA	

Sample ID	Sieve cloth (μ)	Sample type	Total water volume (liters)	Time from 30 – 20 cm (sec)	SS (mg/L)	Total COD (mg/L)	Filtered COD (mg/L)	Comments (Vol filtered and time taken)
22	90	First liter	1,0	NA			NA	
23	90	W/ filter mat					NA	
24	90	W/ filter mat					NA	
25	90	W/ filter mat					NA	
26	55	First liter	1,0	NA			NA	
27	55	W/ filter mat					NA	
28	55	W/ filter mat					NA	
29	55	W/ filter mat					NA	
30	33	First liter	1,0	NA			NA	
31	33	W/ filter mat					NA	
32	33	W/ filter mat					NA	
33	33	W/ filter mat					NA	
34	18	First liter	1,0	NA			NA	
35	18	W/ filter mat					NA	
36	18	W/ filter mat					NA	
37	18	W/ filter mat					NA	
38	11	First liter	1,0	NA			NA	
39	11	W/ filter mat					NA	
40	11	W/ filter mat					NA	
41	11	W/ filter mat					NA	
42	None	Un treated 2	NA	NA				
43	None		NA	NA				Avg. Untreated 1+2

NA: No measurement or analysis

A.6 STANDARD OPERATING PROCEDURE FOR MALVERN MASTER-SIZER 3000

Standard Operating Procedure (SOP) for Malvern Mastersizer 3000: Solids particles and oil droplets size distribution analyses

Prepared by: Carsten U Schwermer, Eilen Arctander Vik and Michael Zettel, 06.02.2012 (version 1).

Quality assured by: Not quality assured

Link to instrument manuals: [Notes Link](#)

Introduction

The purpose of this SOP is to describe a sufficient line of action to ensure stable conditions for operation and to consolidate the methods used.

Measuring Principle

The new Malvern Mastersizer 3000 uses a 633nm red laser and a 470nm blue laser. This allows the instruments to cover the particle size distribution (PSD) from 10nm to 3.5mm (3500 μm). The system is rapidly aligning, has completely encapsulated optics and the instrumental error is very small (1 % precision). The challenge is the sampling method and the handling of the samples.

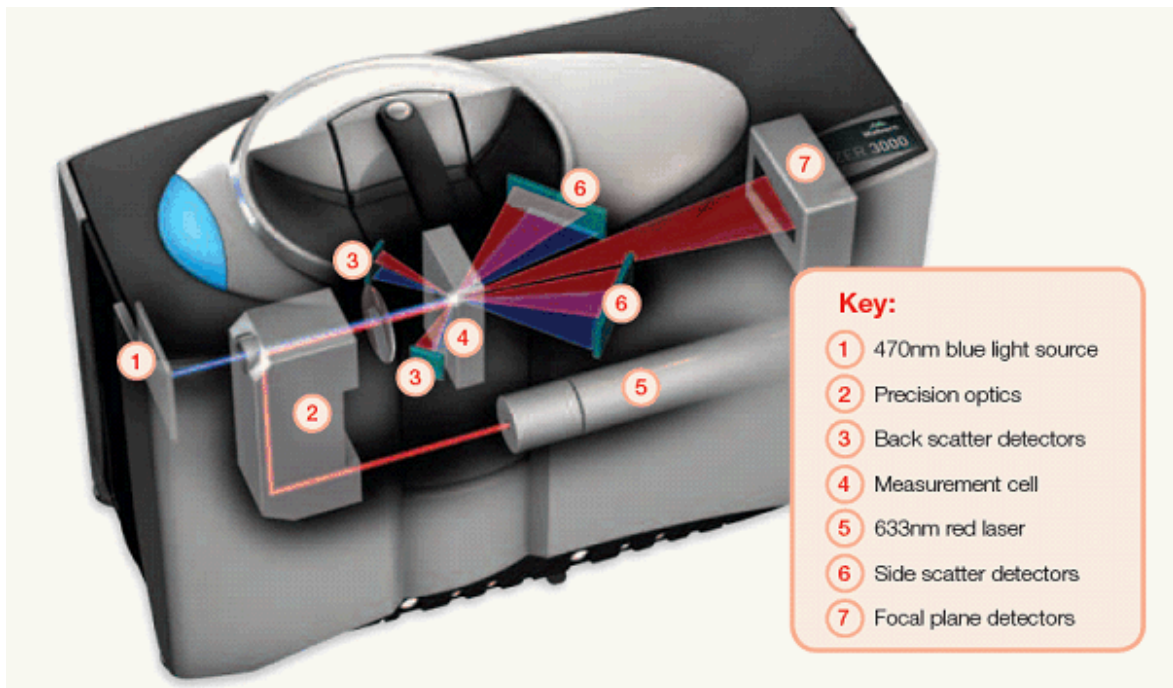

The Standard Operating Procedure (SOP) allows for improving standardization: You can:

1. Observe
2. Interact, and
3. Optimize your system.

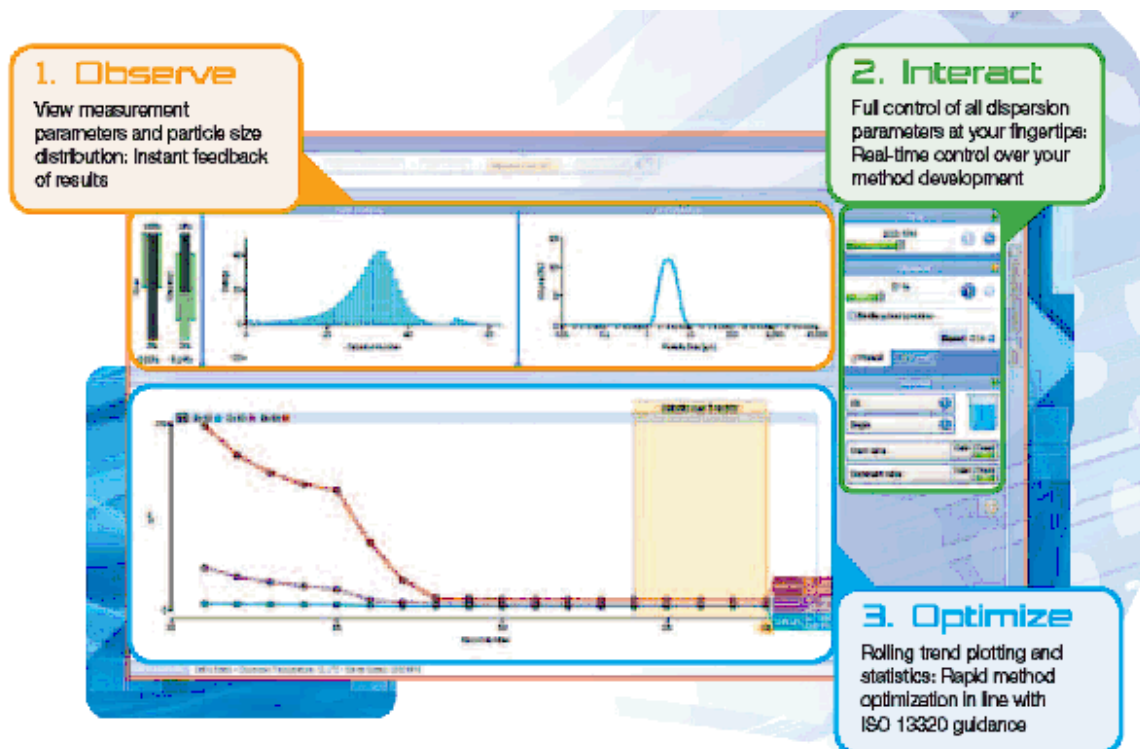

Equipment

- Malvern Mastersizer 3000
- Hydro EV wet cell with 500 ml or 1 L measuring beaker for holding samples
- 2 x 1 L glass bottles with outlet from the bottom & tubing connecting them to the inlet of the flow-through cell
- Tubing allowing emptying of the flow-through cell when the bottle/measuring cylinder is being applied
- Laptop with installed Malvern Mastersizer 3000 software
- Pipettes/measuring cylinders etc needed for dilution of fluids
- Measurement cup 500 or 1000 ml (applicable to the Hydro EV wet cell)
- Distilled water or filtered tap water to minimize the occurrence of particles in the background water and for dilution of samples. When analysing samples of high salinity (e.g. seawater), seawater can be used both as blank and as a diluents if the seawater is filtered with a pore size of 0.45µm.
- Cables for instruments and laptop
- Installed software on laptop included manual and SOP

Site requirements

The site where the Malvern Mastersizer 3000 is to be operated should be:

- Away from strong light sources (e.g. windows)
- Away from strong heat sources (e.g. radiators)
- Well ventilated (for noxious samples)
- On a horizontal vibration free bench which can support the total weight (approx 35 kg) of the system

Setup and operation

Connect all cables according to their specific numbering, e.g. connect cable end marked "1" with slot marked with "1" and continue with cable end marked "2" and connect it with slot marked "2".

For every time a measurement is starting or the lenses has been removed for maintenance, the Malvern Mastersizer 3000 automatically realigns to the background. Unless you take manual control over the measuring sequence, a new background will be measured between each analysis.

OBS!!! Make sure the background is a background sample!! If you forget to change to the background sample, the unit will think your real sample is the background and all your measurements are screwed up!!!!

Using Hydro EV mixing unit

Malvern Mastersizer 3000 has a Wet and a Dry dispersion unit. Aquateam has bought the Exchangeable Volume unit (Hydro EV), see the Figure below. The volume can be varied depending on available sampling volume or purpose of measurement. The Hydro EV unit is applicable when analysing particles in water or stable oil/water emulsions. A stable emulsion is typically occurring when finite solid particles with diameter of approximately 1µm and/or surfactants (detergents, inhibitors etc) are present in the oil/water emulsion making the oil droplet distribution in-sensitive to storage and mixing.

The Hydro EV mixing unit can also be used when you want to study the impact of coagulation/flocculation. You then need to prepare a SOP suitable for your specific test conditions. You could measure samples every 5 seconds to see how flocs are formed, but you have to be very careful with the mixing speed to avoid breaking up the flocs again. If you also

want to control the performance after flotation or sedimentation, you might want to use a special container allowing you to analyse the samples from the intermediate phase of the beaker. A special SOP will be developed for the purpose, but depending on type of flocculant this SOP needs to be flexible.



Bottle/measuring cylinder with direct flow into the measuring cell

The Figure below shows a typical set-up. This set-up is applicable when analysing oil droplets or flocs sensitive to stirring (shearing). This set-up is typically applied when measuring oil-droplets in the fluids. Preferable the samples should be taken from the pipe and run through the measuring cell (in-line cell). When performing flotation experiments, samples can be taken from the bottom of the beaker. A manual SOP must be used for the application of this system. We have in the set-up shown in the Figure established two separate containers, one for the oily water samples and one for the clean water sample. The unit needs to be checked for cleanliness between analyses and that can be done by running a blank sample of clean water in between, and if the obscuration is too high (> 5-10 % deviation), you should clean the optics.

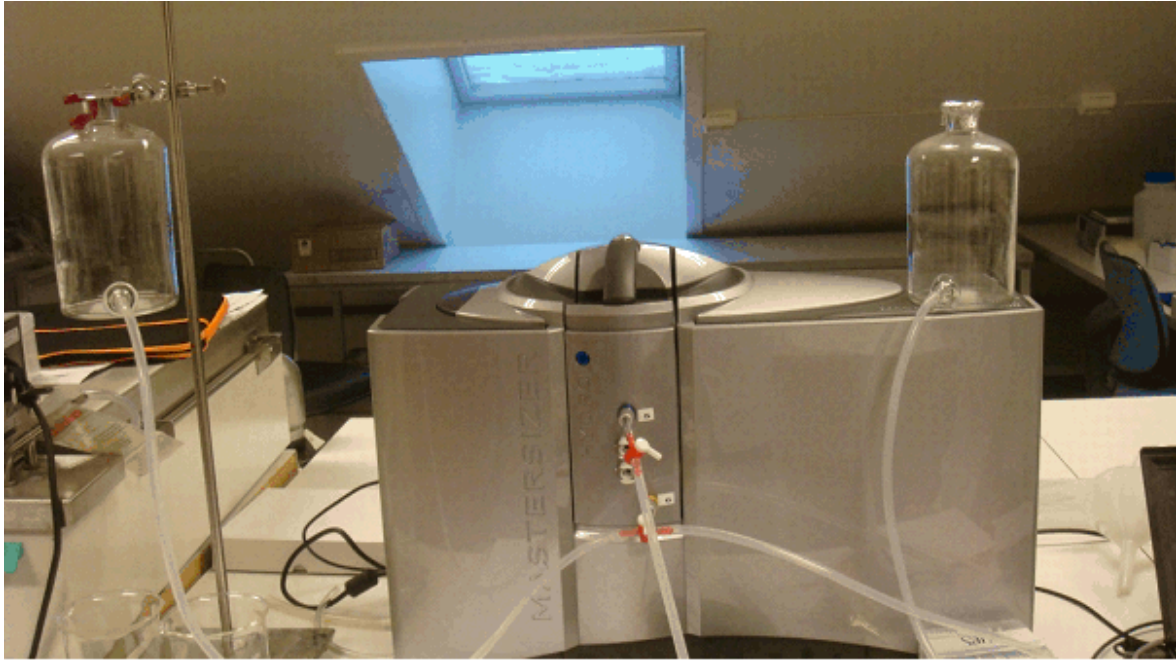

Maintenance

Cleaning the system when the lenses are contaminated is very important. This can be done by using the built-in cleaning option in the software, but this requires access to a cleaning fluid. Another option is to run a blank sample in between a number of measurements, and if the obscuration of the blank exceeds 5-10 % of your reading, you need to clean your system. This is recommended done by using a laboratory detergent. A ZALO solution of "hot water can be used, but the system must be cleaned with hot water with no detergent many times to ensure that the surface active detergent is cleaned off the lenses. The frequency of cleaning depends on the type of samples analysed. When samples with high oil content (dispersed or free oil) is being analysed, the flow-through cell requires more often cleaning. The procedure needs to be established on site with your specific samples.

Power on and create a measurement file

1. 

Connect all cables according to paragraph "Setup and operation"

2. Switch on the optical unit by pressing the . The blue light on top of the instrument indicates that it is on. Leave the instrument powered on for 30 minutes before making measurements to allow its temperature to stabilise.

3. Switch on the laptop, log on and start the appurtenant software by double clicking on the Mastersizer 3000 icon on the desktop.
4. Ensure that the status bar indicates that the instrument is correctly connected see observe in the above Figure
5. Create a new measurement file by clicking **New-Measurement File** from **Home** selection of the control ribbon.
6. Choose **Save as**, name the measurement file **Starter sample.mmes** and store this file in **C:\skrivebord\Mine dokumenter\Malvern Instruments\Mastersizer 3000\Workspace\Measurement datafile name.mmes**. One has to compile with the given criterions for project names when altering the file name.
7. It is important that you keep track of your measurements and which files you want to save using your lab-book. Note down: Sample id, including time of sampling, time of recording on Malvern, measured concentration, any dilution or special treatment made to the samples. It is sometimes difficult to track your samples unless you make a record in your lab-book.

OBS!!! Don't underestimate the importance of these notes. They are gold worth when you need to control some missing information (a dilution or concentration factor!!!)

Make a measurement

1. Select **Run SOP** from the **Measurements** section of the ribbon. The **SOP Selector** window shows all available SOPs for the connected accessory.
2. Choose the right SOP for the purpose:
 - a. SOP for solids
 - b. SOP for oil droplets in emulsions
 - c. Manual SOP for unstable oil droplets
 - d. Manual SOP for coagulation/flocculation/flotation tests
3. The **Measurement Display** window is shown and the progress status bar at the top of the window reflects what is happening and what to do next.
4. Before starting fill the sampling container with your Blank samples. Click the **Start** button to initialize the instrument, automatically fill the tank and cell and then **Measure Background** (the system measures both the red and the blue light values of the background). The filling only starts when you have lowered the mixer.

OBS!! Some times you have to lift the mixer and lower it again for the computer to start the measuring sequence.

5. If the SOP specifies that the operator inputs the sample name, the Sample documentation window is displayed - Enter a name for the sample and click **Ok**.
6. When this is complete, the SOP pauses. The system now requests that you add sample - do this until the **Obscuration Bar** (in the laser panel) indicates about 10-20%. This is a rough guide to a suitable value for a wet dispersion unit. The optimal obscuration value is highly sample dependent - refer to the help system for more information.

OBS!! If you in the SOP has given too narrow range for obscuration, you will not get any result before you are within the given obscuration range. Keep it therefore a little wider than the optimum, but be aware that the uncertainty increases the more you get outside the optimum range. In the lower range, you sometimes do not have the possibility to chose.

7. Click the **Start** button to disperse the sample into the system and then commence the measurement. The system measures first the red and then the blue light values. This SOP makes several measurements. When complete, the **Trend View** is updated with the new measurement figures.

OBS!! When you are using the manual SOP and you have limited amount of samples and need to limit the measuring time, a Guide is that the Red light require longer times for the reading than the blue light, and you can for example use 10 sec for each measurement with the Red light and 5 sec with the Blue light.

8. Complete the measurement by closing the **SOP Measurement** window.
9. The measurement is complete. Proceed to step 3. **Check the results**, see manual.

Exporting data from Malvern Mastersizer 3000

Records from the pane, **Record View**, are exported to Excel by selecting the desired records, but no more than 15 records at a time can be exported due to limitations of the software.

Alternatively, all records can be exported by clicking the button **Export all records**, still with the limitation of 15 records in total to be exported. A new window will then be displayed, showing the chosen records to be exported. Choose the following options from the occurring menu to get the correct format:

1. Ordbrøyer: Choose **Columns**
2. Delimitations: Choose **Tab Limited**
3. Formatting: Choose **Format values as displayed in the software**
4. Header: Choose **Header on**

Click on **Export to file.** and save as a .txt file in directory: **C:\skrivebord\Mine dokumenter\Malvern Instruments\Mastersizer 3000\Workspace\Export data\file name.txt**

Comment: The current software version (v. 1.0) only allows 15 records to be exported at the same time. When exceeding this amount, data will not be aligned in columns but only in rows. This problem is currently undergoing revision by the developer.

Import of .txt file to Excel

Open the imported .txt file in Excel by clicking the option **Open..** under the pane, **Files** in Excel, then choosing the respective file exported from Malvern Mastersizer 3000, see previous section, in the directory **C:\skrivebord\Mine dokumenter\Malvern Instruments\Mastersizer 3000\Workspace\Measurement data\file name.txt**. In the pane, **Filetype**, choose **textfiles**, then select your data file and click on **Open**.

In step one in the import dialog window, choose **Data with separation sign** (option 1) and proceed to step two, where the following options should be chosen: **Tabulator** and **as Textgratification**. Proceed to step three, making no changes. Click on **Finish**. The data presented can be copied and transferred to the Aqt standard Malvern spreadsheet.

SUPPORTING DATA

The standard procedures used for analyses within this study are attached.

B.1 ASSUMED VOLUME FILTERED WITH SALSNES FILTERS WITHOUT MAT FORMATION AT 30 SECONDS FILTRATION TIME

Reactor	Sieve Size (Filt. Time (s)	Vol. filt. (l)	Assumed Volume Filtered after 30 seconds						
				100%	75%	50%	25%	10%	5%	
NFR-R1	55	300.0	0.63			0.3125	0.156	0.063	0.031	
NFR-R1	33	300.0	0.28			0.14	0.07	0.028	0.014	
NFR-R1	18	300.0	0.16				0.04	0.016	0.008	
NFR-R1	11	330.0	0.12				0.03	0.012	0.006	
NFR-R2	18	NA	0.25				0.063	0.025	0.013	
NFR-R2	11	NA	0.30				0.075	0.03	0.015	
NFR-R3	55	NA	0.44			0.22	0.11	0.044	0.022	
NFR-R3	18	NA	0.24				0.06	0.024	0.012	
NFR-R3	11	NA	0.34				0.085	0.034	0.017	
NFR-R4	18	NA	0.60				0.15	0.06	0.03	
NFR-R4	11	NA	0.60				0.15	0.06	0.03	
NFR-R5	33	300	0.60			0.3	0.15	0.06	0.03	
NFR-R5	18	600	0.55				0.138	0.055	0.028	
NFR-R5	11	900	0.60				0.15	0.06	0.03	
NFR-R6	55	300	0.54			0.27	0.135	0.054	0.027	
NFR-R6	33	300	0.28			0.14	0.07	0.028	0.014	
NFR-R6	18	300	0.22				0.055	0.022	0.011	
NFR-R6	11	300	0.10				0.025	0.01	0.005	
NFR-R7	33	300	0.40			0.2	0.1	0.04	0.02	
NFR-R7	18	300	0.32				0.08	0.032	0.016	
NFR-R7	11	300	0.30				0.075	0.03	0.015	
Orange + Poly	NFR-R5	150	NA	0.70	0.7	0.525	0.35	0.175	0.07	0.035
Orange + Poly	NFR-R5	90	NA	0.60			0.3	0.15	0.06	0.03
Orange + Poly	NFR-R5	55	NA	0.50			0.125	0.05	0.025	
Orange + Poly	NFR-R5	33	NA	0.40			0.1	0.04	0.02	
Orange + Poly	NFR-R5	18	NA	0.36			0.09	0.036	0.018	
Orange + Poly	NFR-R5	11	NA	0.38			0.095	0.038	0.019	
Red + Poly	NFR-R5	210	NA	0.82	0.82	0.615	0.41	0.205	0.082	0.041
Red + Poly	NFR-R5	150	NA	0.80			0.4	0.2	0.08	0.04
Red + Poly	NFR-R5	90	NA	0.70			0.35	0.175	0.07	0.035
Red + Poly	NFR-R5	55	NA	0.80			0.4	0.2	0.08	0.04
Red + Poly	NFR-R5	33	NA	0.60			0.15	0.06	0.03	
Red + Poly	NFR-R5	18	NA	0.64			0.16	0.064	0.032	
Red + Poly	NFR-R5	11	NA	0.50			0.125	0.05	0.025	
Sil + Poly	NFR-R5	210	NA	1.00	1	0.75	0.5	0.25	0.1	0.05
Sil + Poly	NFR-R5	150	NA	1.00	1	0.75	0.5	0.25	0.1	0.05
Sil + Poly	NFR-R5	90	NA	0.58			0.29	0.145	0.058	0.029
Sil + Poly	NFR-R5	55	NA	0.90			0.225	0.09	0.045	
Sil + Poly	NFR-R5	33	NA	0.60			0.15	0.06	0.03	
Sil + Poly	NFR-R5	18	NA	0.86			0.215	0.086	0.043	
Sil + Poly	NFR-R5	11	NA	0.70			0.175	0.07	0.035	
Orange + PAX	NFR-R5	90	NA	0.46			0.23	0.115	0.046	0.023
Orange + PAX	NFR-R5	55	NA	0.34			0.17	0.085	0.034	0.017
Orange + PAX	NFR-R5	33	NA	0.20			0.05	0.02	0.01	
Orange + PAX	NFR-R5	18	NA	0.22			0.055	0.022	0.011	
Orange + PAX	NFR-R5	11	NA	0.10			0.025	0.01	0.005	
Red + PAX	NFR-R5	90	NA	0.40			0.2	0.1	0.04	0.02
Red + PAX	NFR-R5	55	120	0.30			0.075	0.03	0.015	
Red + PAX	NFR-R5	33	180	0.10			0.025	0.01	0.005	
Red + PAX	NFR-R5	18	NA	0.10			0.025	0.01	0.005	
Red + PAX	NFR-R5	11	NA	0.10			0.025	0.01	0.005	
Sil + PAX	NFR-R5	90	NA	0.46			0.23	0.115	0.046	0.023
Sil + PAX	NFR-R5	55	600	0.32			0.08	0.032	0.016	
Sil + PAX	NFR-R5	33	NA	0.10			0.025	0.01	0.005	
Sil + PAX	NFR-R5	18	300	0.14				0.014	0.007	
Sil + PAX	NFR-R5	11	NA	0.10				0.01	0.005	

B.2 REMOVAL EFFICIENCIES AND MEAN HYDRAULIC CAPACITY
OF SF SIEVES FOR NFR MBBR R5 EFFLUENT WITHOUT MAT
FORMATION

B.3 SUSPENDED SOLIDS DISTRIBUTION OF FLOCCULATED NFR
MBBR REACTOR 5 EFFLUENT (ORIGINAL DATA)

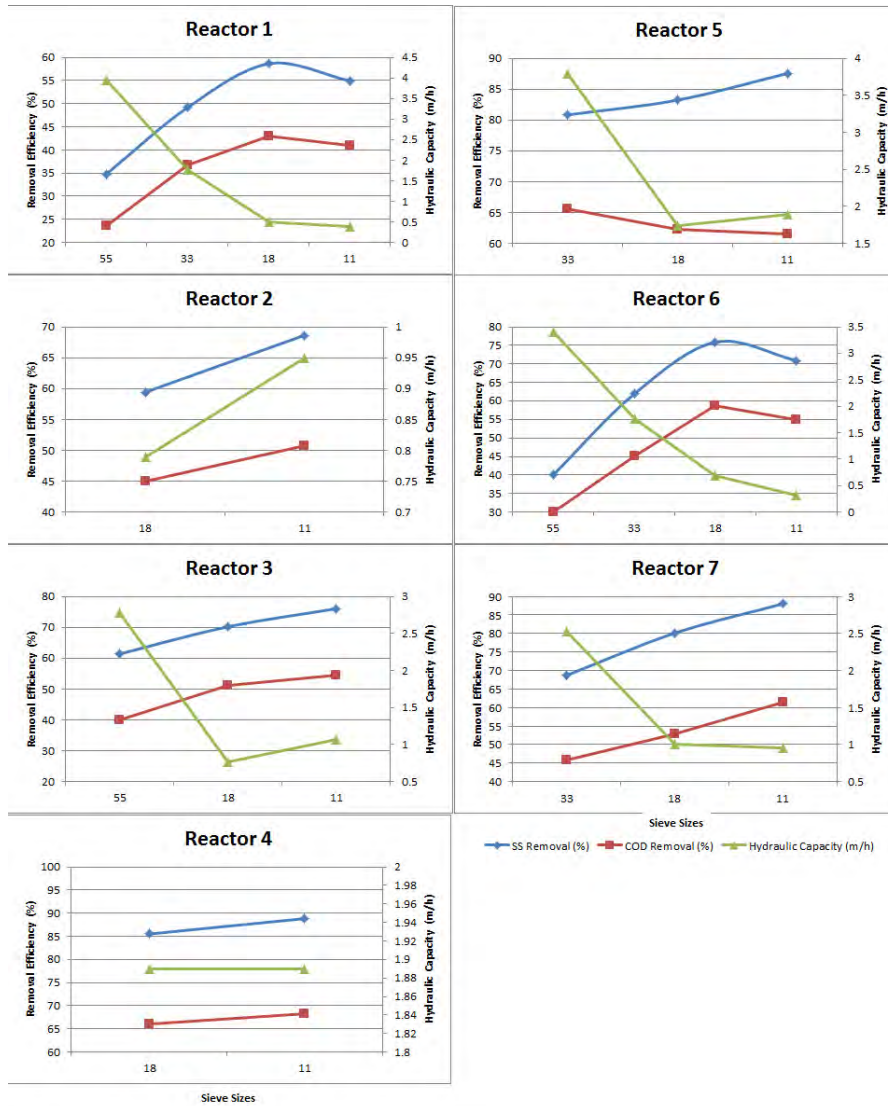

Figure B.1: Removal Efficiencies and mean hydraulic capacity of SF sieves for NFR MBBR R5 Effluent without mat formation

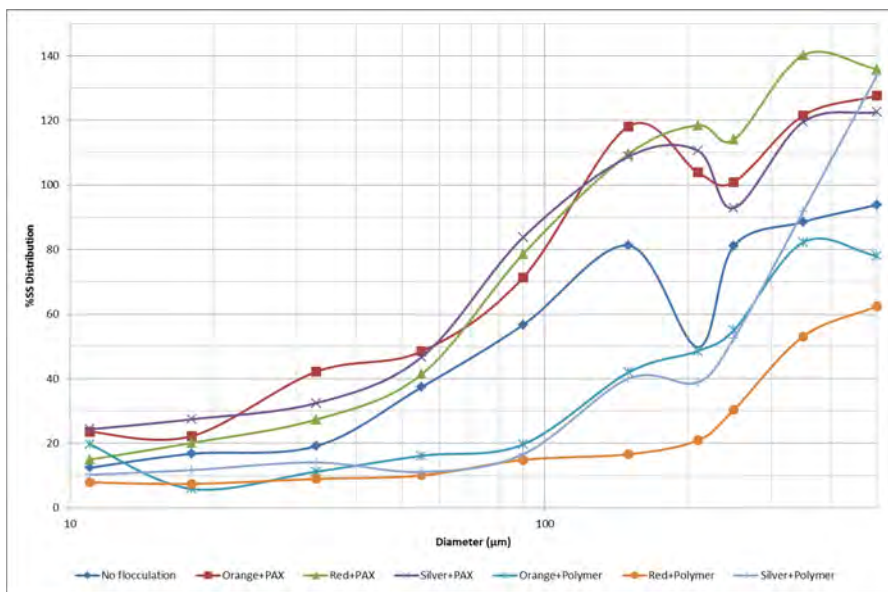

Figure B.2: Suspended solids size distribution from Salsnes Filters Test Apparatus for NFR MBBR R5 Effluent

MATERIAL SAFETY DATA SHEETS

The material safety data sheets ([MSDS](#))s of the chemicals and polymers used are attached.

C.1 MSDS

SIKKERHETSDATABLAD

KEMIRA PAX-XL60

1. Identifikasjon av stoffet / produktet og av selskapet / foretaket

Utgitt dato	12.01.2010
Revisjon	18.02.2010
Kjemikaliets navn	KEMIRA PAX-XL60
Kjemisk navn	Polyaluminiumkloridhydroksidsilikat
CAS-nr.	1327-41-9
EC-nr.	215-477-2
Kjemikaliets bruksområde	Fellingsmiddel for rensing av drikke- og avløpsvann.

Produsent

Firmanavn	Kemira Chemicals AS
Besøksadresse	Øraveien 14
Postnr.	1630
Poststed	Gamle Fredrikstad
Land	N
Telefon	69358585
Telefaks	69358595
E-post	kemira.no@kemira.com
Hjemmeside	http://www.kemira.no
Org. nr.	941559190
Nødtelefon	22591300

2. Fareidentifikasjon

Farebeskrivelse	Irriterer øyne og huden. Produktet er ikke brannfarlig. Store utslipp kan innvirke negativt i vannmiljø pga lokal pH-senkning.
-----------------	--------------------------------------------------------------------------------------------------------------------------------------

3. Sammensetning / opplysning om innholdsstoffer

Komponentnavn	Identifikasjon	Klassifisering	Innhold
Polyaluminiumkloridhydroksidsilikat	CAS-nr.: 1327-41-9 EC-nr.: 215-477-2	Xi; R36/38	35 - 45 %
Kolonneforklaring	CAS-nr. = Chemical Abstracts Service; EU (Einecs- eller Elincsnummer) = European inventory of Existing Commercial Chemical Substances; Ingrediensnavn = Navn iflg. stoffliste (stoffer som ikke står i stofflisten må oversettes hvis mulig). Innhold oppgitt i; %, %vkt/vkt, %vol/vkt, %vol/vol, mg/m ³ , ppb, ppm, vekt%, vol%		
FH/FB/FM	T+ = Meget giftig, T = Giftig, C = Etsende, Xn = Helseskadelig, Xi = Irriterende, E = Eksplosiv, O = Oksiderende, F+ = Ekstremt brannfarlig, F = Meget brannfarlig, N = Miljøskadelig.		

4. Førstehjelpstiltak

Innånding	Frisk luft. Skyll nese, munn og svelg med vann.
Hudkontakt	Fjern forurenset tøy. Skyll huden med mye vann. Kontakt lege hvis irritasjon vedvarer.
Øyekontakt	Skyll øyeblikkelig med vann i 10-15 min. Hold øynene åpne. Gni ikke i øyet! Kontakt lege.

Svelging	Drikk straks et par glass vann eller melk. Fremkall ikke brekninger. Kontakt lege ved vedvarende symptomer.
Informasjon til helsepersonell	Hvis lege skal kontaktes, anvendes dette HMS-datablad som informasjonskilde.

5. Tiltak ved brannslukning

Passende brannslukningsmiddel	Ikke brannfarlig, velg slukningsmiddel etter omgivelsene.
Uegnet brannslukningsmiddel	Ingen restriksjoner
Brann- og eksplosjonsfarer	Ikke brannfarlig. Ved oppvarming dannes giftige og etsende gasser (saltsyregass).
Personlig verneutstyr	Bruk selvforsynt åndedrettsvern, friskluftmaske og beskyttelsesklær. Risiko for dannelse av giftige gasser.

6. Tiltak ved utilsiktet utslipp

Sikkerhetstiltak for å beskytte personell	Bruk vernebriller og hansker ved håndtering, se pkt 8. Evakuer overflødig personell. Øyespyleflaske skal være tilgjengelig.
Sikkerhetstiltak for å beskytte ytre miljø	Større mengder må ikke tømmes i kloakk og dem opp for spredning av utslipp til ytre miljø. Nøytraliser med kalk og absorber i sand.
Metoder til opprydding og rengjøring	Gjør rent med vann.
Andre anvisninger	Ved større utslipp til vann, kontakt politi/redningstjeneste.

7. Håndtering og lagring

Håndtering	Håndter produktet slik at søl og damp ikke oppstår.
Oppbevaring	Lagres på containere/tanker merket "IRRITERENDE". Skal ikke lagres i temperatur under 0°C. Ved langtidslagring bør temp. ikke overstige +20°C . Bruk glassfiberarmerte polyestertanker med Deracane 411/45 ECR-glass innerskikt (sperreskikt). Lagringsstabilitet: Stabilt i minst 6 mnd.
Spesielle egenskaper og farer	Irriterende

8. Eksponeringskontroll / personlig verneutstyr

Eksponeringskontroll

Begrensning av eksponering på arbeidsplassen	Sørg for god ventilasjon. Beskyttelse mot sprut. Vask hendene godt ved kontakt med produktet. Nøddusj skal finnes på stedet
Åndedrettsvern	Gassmaske med patron for partile (P2).
Håndvern	Hansker av naturgummi, neopren, nitril, PVC eller viton. Gjennomtrengningstid > 8 timer.
Øyevern	Bruk tettsittende vernebriller. Øyespyleflasker skal være tilgjengelig.
Annet hudvern enn håndvern	Fullstendig kjemikaliebestandig dress og støvler ved behov.

9. Fysiske og kjemiske egenskaper

Tilstandsform	Flytende
Lukt	Ubetydelig
Farge	Svakt gul farget klar væske
Løselighet i vann	Fullstendig løselig ved 20°C
Løselighet i fett	Ikke fettløslig
Relativ tetthet	1300-1330 kg/m ³
Smeltepunkt/smeltepunktintervall	-25
Smeltepunkt/smeltepunktintervall	Verdi: °C
Kokepunkt/ kokepunktintervall	100-120
Kokepunkt/ kokepunktintervall	Verdi: °C

pH (handelsvare)	pH 1 - 2
------------------	----------

10. Stabilitet og reaktivitet

Forhold som skal unngås	Unngå høye temperaturer og frysing.
Materialer som skal unngås	Stål, galvaniserte overflater. Unngå kontakt med kloritt, hypokloritt, sulfitt, nitritt, nitrat og ulegert stål.
Farlige spaltningsprodukter	Ved oppvarming >200°C kan saltsyregass dannes.
Stabilitet	Produktet er stabilt ved normal lagring.

11. Toksikologisk informasjon

Toksikologisk informasjon

Oral toksisitet	LD50, rotte (mg/kg) >2000
-----------------	---------------------------

Øvrige helsefareopplysninger

Generelt	Damp virker irriterende på slimhinner, øyne og åndedretsorganer
Innånding	Innånding av aerosoler kan gi sviing, hoste og pustebesvær.
Hudkontakt	Irritasjon, rødflammethet og eksem-lignende besvær
Øyekontakt	Damp kan virke irriterende på øyne
Svelging	Svelging kan gi magesmerter og oppkast. Kan virke irriterende i munn, svelg og mage.

12. Miljøopplysninger

Toksikologisk informasjon

Akvatisk kommentarer	Bioakkumuleres ikke.
----------------------	----------------------

Øvrige miljøopplysninger

Økotoksisitet	<p>LC50/96h/Danio rerio: > 1000 mg/l EC50/48h/Daphnia magna: 98 mg/l IC50/72h/Alga: Ikke relevant i algetest da fosforet felles ut som aluminiumfosfat. Dessuten er aluminium maskert av algevekstmedium i testen (pkt. 16.4). NOEC Danio rerio: >1000 mg/l NOEC Daphnia magna: 40 mg/l (= 3.6 mg total Al/l, både i løslig og utfelt form)</p> <p>Da langtidsløseligheten (28 dager) ligger i området 0.006 - 0.035 mg/Al/l, blir ikke stoffet klassifisert som farlig for miljøet. Klassifiseres ikke som giftig eller skadelig i vannmiljø (pkt. 16.4).</p>
Persistens og nedbrytbarhet	Bionedbrytbarhet er ikke relevant for et uorganisk produkt som dette. Da produktet mineraliseres umiddelbart ved normale betingelser, ansees produktet å være lett nedbrytbar. Ved hydrolyse dannes ufarlig aluminiumhydroksid i pH-området 5-7. Denne fellingen anses som ufarlig for alge, daphnia og fisk.
Andre skadevirkninger / annen informasjon	<p>Ved normale doseringsmengder vil det ikke oppnås konsentrasjonsnivåer som virker toksisk på vannlevende organismer. Hvis fosfat finnes, dannes metallfosfater. Ved unormalt høye konsentrasjoner som følge av utslipp vil pH-verdien synke i vannfasen og vannets buffringsevne reduseres, og i så fall kan dette skade vannlevende organismer (fisk).</p> <p>Store utslipp kan virke negativt i et vannmiljø pga lokal pH-senkning.</p>

13. Fjerning av kjemikalieavfall

Avfallskode EAL	060314
NORSAS	7132
Produktet er klassifisert som farlig avfall	Ja
Annen informasjon	Spill og rester fortynnes med vann og nøytraliseres med kalk (hydratkalk).

Rester kan eventuelt behandles som spesialavfall der Kemira Chemicals A/S tar varen i retur for gjenbruk og sluttdisponering.
Emballasje kildesorteres eller destrueres i henhold til gjeldende norsk regelverk.

14. Transportinformasjon

Varenavn (nasjonalt)	ETSENDE VÆSKE, SUR, UORGANISK, N.O.S.
Farlig gods ADR	Status: Ja UN-nr.: 3264 Klasse: 8 Fare nr.: 80 Emballasjegruppe: III Varenavn: ETSENDE VÆSKE, SUR, UORGANISK, N.O.S.
Farlig gods RID	UN-nr.: 3264 Klasse: 8 Emballasjegruppe: III Varenavn: ETSENDE VÆSKE, SUR, UORGANISK, N.O.S.
Farlig gods IMDG	Status: Ja UN-nr.: 3264 Klasse: 8 Emballasjegruppe: III EmS: F-A, S-B Varenavn: CORROSIVE LIQUID, ACIDIC, INORGANIC, N.O.S.
Farlig gods ICAO/IATA	Status: Ja UN-nr.: 3264 Klasse: 8 Emballasjegruppe: III Varenavn: CORROSIVE LIQUID, ACIDIC, INORGANIC, N.O.S.
Andre relevante opplysninger	Produktet er klassifisert som farlig gods da det er svakt etsende på metaller iflg ADR-test 2800 (3) (f).

15. Opplysninger om lover og forskrifter

Faresymbol



Irriterende

Sammensetning på merkeetiketten	Polyaluminiumkloridhydroksidsilikat: 35 - 45 %
EC-nr.	215-477-2
R-setninger	R-36/38 Irriterer øynene og huden.
S-setninger	S26 Får man stoffet i øynene, skyll straks med vann og kontakt lege. S28 - Får man stoff på huden, vaskes straks med vann. S36 Bruk egnede verneklær S37 Bruk vernehansker. S39 Bruk vernehansker og ansiktsskjerm.
Referanser (Lover/Forskrifter)	1. Klassifisering og merking av farlige kjemikalier i Norge (stofflisten). 2. Administrativ norm for arbeid med kjemikalier. 3. Forskrift om vern mot eksponering for kjemikalier på arbeidsplassen (kjemikalieforskriften). 4. Databladforskriften, revidert forskrift nr 1323 per 16.07.02. 5. Lov om transport av farlig gods.
Deklarasjonsnr.	23573

16. Andre opplysninger

Liste over relevante R-setninger (i seksjon 2 og 3).	R36/38 Irriterer øynene og huden.
Viktigste kilder ved utarbeidelsen av Sikkerhetsdatabladet (ikke norske)	1. Hommel, Handbuch der gefährlichen Güter 2. European Standard SS-EN 883 3. NIVA Study G 003/1-3 4. Fraunhofer-Institute for Molecular, Germany. Ecotoxicology-study pkt. 12. 5. Säkerhetsdatablad Kemwater TM PAX-XL60 25.10.2002 Skjelmose/Wall
Opplysninger som er nye, slettet eller revidert	Endringer i pkt.9 og 12
Leverandørens anmerkninger	Innholdet i dette HMS-databladet er basert på de opplysninger som vi er kjent med ved bladets siste utgave.
Ansvarlig for Sikkerhetsdatablad	Kemira Chemicals AS



MSDS: 0004228
Print Date: 10/01/2006
Revision Date: 09/26/2006

MATERIAL SAFETY DATA SHEET

1. CHEMICAL PRODUCT AND COMPANY IDENTIFICATION

Product Name: SUPERFLOC® C-496 Flocculant
Synonyms: None
Chemical Family: Cationic Polyacrylamide
Molecular Formula: Polymer
Molecular Weight: Polymer

KEMIRA WATER SOLUTIONS, INC., 808 EAST MAIN STREET, LAKELAND, FLORIDA 33801, USA
For Product Information call 1-800/879-6353. Outside the USA and Canada call 1-785/842-7424.
EMERGENCY PHONE: For emergency involving spill, leak, fire, exposure or accident call CHEMTREC: 1-800/424-9300.
Outside the USA and Canada call 1-703/527-3887.

® indicates trademark registered in the U.S. Outside the U.S., mark may be registered, pending or a trademark. Mark is or may be used under license.

2. COMPOSITION/INFORMATION ON INGREDIENTS

OSHA REGULATED COMPONENTS

Component / CAS No.	% (w/w)	OSHA (PEL):	ACGIH (TLV)	Carcinogen
Adipic acid 124-04-9	~ 4.5	Not established	5 mg/m ³ (TWA)	-

3. HAZARDS IDENTIFICATION

EMERGENCY OVERVIEW

APPEARANCE AND ODOR:

Color: off white
Appearance: crystalline powder
Odor: odorless

STATEMENTS OF HAZARD:

CAUTION! MAY CAUSE EYE AND SKIN IRRITATION

POTENTIAL HEALTH EFFECTS

EFFECTS OF EXPOSURE:

The estimated acute oral (rat) LD50, acute dermal (rabbit) LD50 and 4-hour inhalation (rat) LC50 values for this material are >5,000 mg/kg, >2,000 mg/kg and >20 mg/L, respectively. Direct contact with this material may cause mild eye and skin irritation. Refer to Section 11 for toxicology information on the regulated components of this product.

4. FIRST AID MEASURES

Ingestion:

If swallowed, call a physician immediately. Only induce vomiting at the instruction of a physician. Never give anything by mouth to an unconscious person.

Skin Contact:

Wash immediately with plenty of water and soap.

Eye Contact:

Rinse immediately with plenty of water for at least 15 minutes.

Inhalation:

Remove to fresh air. If breathing is difficult, give oxygen. Obtain medical advice if there are persistent symptoms.

5. FIRE-FIGHTING MEASURES

Suitable Extinguishing Media:

Use water spray or fog, carbon dioxide or dry chemical.

Protective Equipment:

Firefighters, and others exposed, wear self-contained breathing apparatus.

Special Hazards:

Dust may be explosive if mixed with air in critical proportions and in the presence of a source of ignition.

6. ACCIDENTAL RELEASE MEASURES

Personal precautions:

Refer to Section 8 (Exposure Controls/Personal Protection) for appropriate personal protective equipment.

Methods For Cleaning Up:

Slippery when wet. Sweep up into containers for disposal. Flush spill area thoroughly with water and scrub to remove residue. If slipperiness remains apply more dry-sweeping compound. Prevent liquid entering sewers.

7. HANDLING AND STORAGE

HANDLING

Precautionary Measures: Avoid contact with eyes, skin and clothing. Wash thoroughly after handling.

Special Handling Statements: Maintain good housekeeping to control dust accumulations.

STORAGE

Material is hygroscopic and should not be exposed to moisture in order to maintain product integrity. To avoid product degradation and equipment corrosion, do not use iron, copper or aluminum containers or equipment.

Storage Temperature: Room temperature

Reason: Integrity.

8. EXPOSURE CONTROLS/PERSONAL PROTECTION

8. EXPOSURE CONTROLS/PERSONAL PROTECTION

Engineering Measures:

Engineering controls are not usually necessary if good hygiene practices are followed.

Respiratory Protection:

Where exposures are below the established exposure limit, no respiratory protection is required. Where exposures exceed the established exposure limit, use respiratory protection recommended for the material and level of exposure.

Eye Protection:

Wear eye/face protection such as chemical splash proof goggles or face shield.

Skin Protection:

Avoid skin contact. Wear impermeable gloves and suitable protective clothing.

Additional Advice:

Before eating, drinking, or smoking, wash face and hands thoroughly with soap and water.

9. PHYSICAL AND CHEMICAL PROPERTIES

Color:	off white
Appearance:	crystalline powder
Odor:	odorless
Boiling Point:	Not applicable
Melting Point:	Not available
Vapor Pressure:	Not applicable
Specific Gravity/Density:	0.75(Bulk density)
Vapor Density:	Not applicable
Percent Volatile (% by wt.):	7 - 8
pH:	3 - 5(0.5% aqueous solution)
Saturation In Air (% By Vol.):	Not applicable
Evaporation Rate:	Not applicable
Solubility In Water:	Limited by viscosity
Volatile Organic Content:	Not applicable
Flash Point:	Not applicable
Flammable Limits (% By Vol):	Not applicable
Autoignition Temperature:	>150 °C 302 °F
Decomposition Temperature:	>150 °C 302 °F
Partition coefficient (n-octanol/water):	Not applicable
Odor Threshold:	Not available

10. STABILITY AND REACTIVITY

Stability:	Stable
Conditions To Avoid:	Avoid contact with alkaline materials which will degrade the polymer.
Polymerization:	Will not occur
Conditions To Avoid:	None known
Materials To Avoid:	Strong oxidizing agents.

Hazardous Decomposition Products:

carbon dioxide
carbon monoxide
ammonia
hydrogen chloride
oxides of nitrogen
oxides of sulfur (includes sulfur di and tri oxides)

11. TOXICOLOGICAL INFORMATION

Toxicological information for the product is found under Section 3. HAZARDS IDENTIFICATION. Toxicological information on the regulated components of this product is as follows:

Adipic acid has an acute oral LD50 (rat) value of greater than 11,000 mg/kg. Direct eye contact caused moderate irritation in rabbits. Contact with skin can cause drying, cracking, and mild irritation. Inhalation of vapor can irritate mucous membranes of the upper respiratory tract, causing coughing and sneezing. Rare instances of immediate hypersensitive asthmatic reactions have been reported.

California Proposition 65 Warning (applicable in California only) - This product contains (a) chemical(s) known to the State of California to cause cancer.

12. ECOLOGICAL INFORMATION

This material is not classified as dangerous for the environment.

Acute toxicity tests conducted using environmentally representative water gave the following results:

The effects on aquatic organisms are due to an external (non-systemic) mode of action, and are significantly reduced (by a factor of 7-20) within 30 minutes due to binding of the product to dissolved organic carbon and inorganic sorbents such as clays and silts.

ALGAE TEST RESULTS

Test: Growth Inhibition (OECD 201)

Due to the cationicity of the polymer, an algae growth inhibition test is not appropriate.

FISH TEST RESULTS

Test: Acute toxicity, freshwater (OECD 203)

Duration: 96 hr.

Species: Zebra Fish (Brachydanio rerio)

>1 - 10 mg/l LC50

Information based on a structurally similar material

INVERTEBRATE TEST RESULTS

Test: Acute Immobilization (OECD 202)

Duration: 48 hr

Species: Water Flea (Daphnia magna)

12. ECOLOGICAL INFORMATION

>10 - 100 mg/l

EC50

Information based on a structurally similar material

DEGRADATION

Test: CO2 Evolution: Modified Sturm (OECD 301B)**Duration:** 28 day

<70 %

Procedure: Ready biodegradability

Information based on a structurally and compositionally similar material. This material is not readily biodegradable (OECD 301B), but degradable by hydrolysis. The large polymer size is incompatible with transport across biological membranes and diffusion; the bioconcentration factor is therefore considered to be zero.

13. DISPOSAL CONSIDERATIONS

The information on RCRA waste classification and disposal methodology provided below applies only to the product, as supplied. If the material has been altered or contaminated, or it has exceeded its recommended shelf life, the guidance may be inapplicable. Hazardous waste classification under federal regulations (40 CFR Part 261 et seq) is dependent upon whether a material is a RCRA `listed hazardous waste` or has any of the four RCRA `hazardous waste characteristics`. Refer to 40 CFR Part 261.33 to determine if a given material to be disposed of is a RCRA `listed hazardous waste`; information contained in Section 15 of this MSDS is not intended to indicate if the product is a `listed hazardous waste`. RCRA Hazardous Waste Characteristics: There are four characteristics defined in 40 CFR Section 261.21-61.24: Ignitability, Corrosivity, Reactivity, and Toxicity. To determine Ignitability, see Section 9 of this MSDS (flash point). For Corrosivity, see Sections 9 and 14 (pH and DOT corrosivity). For Reactivity, see Section 10 (incompatible materials). For Toxicity, see Section 2 (composition). Federal regulations are subject to change. State and local requirements, which may differ from or be more stringent than the federal regulations, may also apply to the classification of the material if it is to be disposed. The Company encourages the recycle, recovery and reuse of materials, where permitted, as an alternate to disposal as a waste. The Company recommends that organic materials classified as RCRA hazardous wastes be disposed of by thermal treatment or incineration at EPA approved facilities. The Company has provided the foregoing for information only; the person generating the waste is responsible for determining the waste classification and disposal method.

14. TRANSPORT INFORMATION

This section provides basic shipping classification information. Refer to appropriate transportation regulations for specific requirements.

US DOT

Proper Shipping Name: Not applicable/Not regulated

Hazardous Substances:

Not applicable

TRANSPORT CANADA

Proper Shipping Name: Not applicable/Not regulated

ICAO / IATA

Proper Shipping Name: Not applicable/Not regulated
Packing Instructions/Maximum Net Quantity Per Package:
Passenger Aircraft: -
Cargo Aircraft: -

IMO

Proper Shipping Name: Not applicable/Not regulated

15. REGULATORY INFORMATION

INVENTORY INFORMATION

United States (USA): All components of this product are included on the TSCA Chemical Inventory or are not required to be listed on the TSCA Chemical Inventory.

Canada: All components of this product are included on the Domestic Substances List (DSL) or are not required to be listed on the DSL.

European Union (EU): All components of this product are included on the European Inventory of Existing Chemical Substances (EINECS) or are not required to be listed on EINECS.

Australia: All components of this product are included in the Australian Inventory of Chemical Substances (AICS).

China: All components of this product are included on the Chinese inventory or are not required to be listed on the Chinese inventory.

Japan: All components of this product are included on the Japanese (ENCS) inventory or are not required to be listed on the Japanese inventory.

Korea: All components of this product are included on the Korean (ECL) inventory or are not required to be listed on the Korean inventory.

Philippines: All components of this product are included on the Philippine (PICCS) inventory or are not required to be listed on the Philippine inventory.

OTHER ENVIRONMENTAL INFORMATION

The following components of this product may be subject to reporting requirements pursuant to Section 313 of CERCLA (40 CFR 372), Section 12(b) of TSCA, or may be subject to release reporting requirements (40 CFR 307, 40 CFR 311, etc.) See Section 13 for information on waste classification and waste disposal of this product.

This product does not contain any components regulated under these sections of the EPA

PRODUCT HAZARD CLASSIFICATION UNDER SECTION 311 OF SARA

- Not applicable
-

16. OTHER INFORMATION

NFPA Hazard Rating (National Fire Protection Association)

Health: 1 - Materials that, under emergency conditions, can cause significant irritation.

Fire: 1 - Materials that must be preheated before ignition can occur.

Reactivity: 0 - Materials that in themselves are normally stable, even under fire exposure conditions.

Reasons For Issue: New Format

This information is given without any warranty or representation. We do not assume any legal responsibility for same, nor do we give permission, inducement, or recommendation to practice any patented invention without a license. It is offered solely for your consideration, investigation, and verification. Before using any product, read its label.
