



Universitetet
i Stavanger

DET TEKNISK-NATURVITENSKAPELIGE FAKULTET

MASTEROPPGAVE

Studieprogram/spesialisering: Offshore teknologi - konstruksjon	Vårsemesteret, 2008 Åpen / Konfidensiell
Forfatter: Sindre Fjelde (signatur forfatter)
Faglig ansvarlig: Ove Tobias Gudmestad Veileder(e): Eldar Tjelta	
Tittel på masteroppgaven: Stability and motion response analyses of transport with barge	
Studiepoeng: 30	
Emneord: <ul style="list-style-type: none">- Barge- Stability- Motion response	Sidetall: 104 + vedlegg/annet: 33 Stavanger, 15.06.08

Abstract

The water has been used for transportation for ages. The barge started early to become one of the most effective methods to perform such an operation. Over the years the floating flat-bottomed structure has been developed until the one we use today which is characterised by its flat bottom and large deck area.

An offshore transport can be divided into three phases, each having its own considerations. The first phase may be called on-loading and here the stability is important. The next phase is named the transport. Here the most important aspect is the motion responses of the barge to the physical environmental conditions. Especially the waves give the barge accelerations which may cause movement of the cargo. To prevent this movement seafastening has to be designed to withstand the forces created by the accelerations. The last phase is the off-loading. Here resonance is the main problem. This phenomenon may cause large motions and accelerations and thereby cause the whole operation to be postponed.

The stability analysis is used to decide the intact stability and the damaged stability. The results are compared with criteria given in DNV(1996) and Noble Denton (2005). The requirements states whether the operation is secure according to the stability principle.

The motion response analysis uses physical environmental conditions given by Noble Denton (2005) to find the accelerations due to the motions. The seafastening need to be designed according to these accelerations to have a secure transport.

The case study included in this report is the analyses of stability and motion response of a barge loaded with 4 bridges and 2 towers. The barge is subjected to physical environmental conditions according to the Valhall field in the southern North Sea (Grant, 2005).

A program package called SESAM, including the programs GeniE, HydroD and POSTRESP, is used to perform the analyses.

The main results give a range of stability of 76,8 degrees for intact stability and 61,8 degrees for damaged stability with two adjacent flooded tanks. Both these are on the correct side of the requirements.

For the motion responses the accelerations for each module is presented in Table a.

Table a: Accelerations in the x, y and z directions due to barge motion.

	Combined accelerations		
	x [$\frac{m}{s^2}$]	y [$\frac{m}{s^2}$]	z [$\frac{m}{s^2}$]
Cargo	surge - yaw - pitch	sway - yaw - roll	heave - pitch - roll
Bridge 6	0,67	1,76	3,19
Bridge 7	0,70	1,30	2,42
Bridge 8	0,50	1,41	2,41
Bridge 9	0,68	1,27	2,36
WP Tower North	1,06	1,92	1,72
WP Tower South	1,08	2,11	2,34

The accelerations presented in Table can, in addition to gravity forces from heel and trim, be used to design the seafastening.

Acknowledgements

This thesis was done at the University of Stavanger during the spring semester 2008. The report looks at a barge transport and attempts to explain the most common theory regarding such a transport analysis.

I would like to thank Fabricom for their support during my work. Especially I would like to thank Eldar Tjelta which has been a priceless source of knowledge and guidance. From the same company I would also like to thank Kåre Mortensen which has been helping with some calculations and information.

From the University of Stavanger I would like to thank Ove Tobias Gudmestad for taking the time to proofread the report meticulously and by this way making it better. I would also like to thank him for the patience for revising some sections of the theory several times until they were right.

Sindre Fjelde

Table of contents

Acknowledgements	I
Table of contents	II
List of figures	V
List of tables	VII
Nomenclatur	VIII
1. Introduction	1
1.1. Historical overview	1
1.2. Study objectives	2
2. State of art	4
2.1. Barge vs. supply ship	4
2.2. Barge vs. heavy lifter	5
2.3. Barge selection and availability	6
2.4. Classification	7
3. Transport phases	9
3.1. On-loading of cargo	9
3.1.1. Roll on, Roll off	9
3.1.2. Lift on, lift off.....	10
3.1.3. Float on, float off.....	10
3.1.4. Skidding	11
3.1.5. Combinations	12
3.1.6. Ballast.....	12
3.1.7. Load out grillage	14
3.2. The transport	16
3.2.1. Barge stability	16
3.2.1.1. Undamaged stability.....	17
3.2.1.2. Damaged stability.....	17
3.2.2. Motions of the barge	17
3.2.2.1. Resonance.....	18
3.2.2.2. Accelerations	19
3.2.2.3. Seafastening	19
3.2.2.4. Fatigue.....	22
3.2.2.5. Motion damping	22
3.2.2.6. Other considerations.....	23
3.3. Off-loading of cargo	24
3.3.1. Resonance.....	24
3.3.2. ”second wave hit”	24
4. Theoretical subjects	26
4.1. Buoyancy and stability	26
4.1.1. Buoyancy: Archimedes’ principle.....	26
4.1.2. Stability	28
4.1.2.1. Intact stability	28
4.1.2.2. Stability at large angles of heel	32
4.1.2.3. Free surface and the effect on stability.....	33
4.1.2.4. Damaged stability.....	33
4.2. Physical environment	35

4.2.1.	Water and air	35
4.2.2.	Wind	35
4.2.3.	Wave theory	35
4.2.3.1.	Description of ocean waves.....	38
4.2.3.1.1.	Deterministic approach	38
4.2.3.1.2.	Probabilistic approach.....	39
4.3.	Ship motions.....	39
4.3.1.	Natural periods	40
4.3.1.1.	TAdded mass.....	41
4.3.1.2.	Resonance.....	41
4.3.2.	Natural periods: Undamped motion in still water	43
4.3.2.1.	Natural periods excluded added mass	44
4.3.2.1.1.	Roll.....	44
4.3.2.1.2.	Pitch.....	46
4.3.2.1.3.	Heave.....	47
4.3.2.2.	Natural periods included added mass.....	49
4.3.3.	Damped motion in still water	53
4.3.4.	Motion in regular waves.....	54
4.3.5.	Motion in irregular waves	55
4.3.5.1.	Wave spectra	55
4.3.5.2.	Response Amplitude Operators (RAO).....	59
4.3.6.	Surge, sway and yaw	62
4.4.	Motions and forces	62
4.4.1.	Roll.....	62
4.4.2.	Pitch.....	63
4.4.3.	Heave.....	64
5.	Design Criteria.....	66
5.1.	Physical environmental conditions.....	66
5.2.	Stability	68
5.2.1.	Intact stability.....	68
5.2.2.	Damaged stability.....	70
5.2.3.	Draft and trim	71
5.3.	Motion Response.....	71
5.4.	Summary	73
6.	Case Study.....	75
6.1.	Analysis data	75
6.1.1.	Barge data.....	75
6.1.2.	Cargo data	75
6.2.	Analysis method.....	76
6.2.1.	The modelling process	77
6.2.2.	Stability analysis	81
6.2.3.	Motion response analysis	81
6.2.4.	POSTRESP.....	81
6.3.	Analysis results	84
6.3.1.	Draught and trim	84
6.3.2.	Intact stability.....	85
6.3.3.	Damaged stability.....	86
6.3.4.	Motion response	86
7.	Conclusions	89
7.1.	Conclusions for the case study.....	89

- 7.1.1. Draught and trim 90
- 7.1.2. Intact stability 90
- 7.1.3. Damaged stability 91
- 7.1.4. Motion response 91
- 8. References 92**
- Appendix: Overview of ballast tanks A-1**
- Appendix: Analysis tools B-3**
- GeniE B-3
- HydroD B-4
- Stability B-5
- WADAM B-5
- POSTRESP B-6
- Appendix: Results from POSTRESP C-11**
- Response variables C-11
- Wave spectra C-16
- Response spectrum for motion C-17
- Response spectra acceleration C-24
- Response spectrum for combined accelerations C-31

List of figures

Figure 1: Mighty Servant transporting an offshore platform	5
Figure 2: Roll on to barge using hydraulic axles. (Macswen, 2004).....	10
Figure 3: Skidding of a topside module to cargo barge. (Macswen, 2004).....	12
Figure 4: Plate girder grillage (Macswen, 2004).....	15
Figure 5: Development of barge cross sections from the 1970's to 2000. (Macswen, 2004)	15
Figure 6: The six degrees of freedom.....	18
Figure 7: Typical lashing arrangement. (Macswen, 2004).....	20
Figure 8: Simple shear plate securing. (Macswen, 2004)	21
Figure 9: Example brace arrangement (Macswen, 2004).....	22
Figure 10: Bilge keel	23
Figure 11: Floating body (Tupper, 2004).....	27
Figure 12: Fake metacentre amd metacentric height	29
Figure 13: Stable (a), neutral (b), and unstable (c) equilibrium in the upright position. The hull is shown inclined by an outside force to demonstrate the tendency in each case. (Gillmer and Johnson, 1982)	30
Figure 14: Terms used to calculate metacentric height (Gillmer and Johnson, 1982).....	31
Figure 15: Explanation of symbols (Tupper, 2004)	32
Figure 16: GZ-curve (Tupper, 2004).....	33
Figure 17: Wave Fourier composition (Ochi 1998).....	36
Figure 18: Alternative approaches for describing ocean waves (Wilson, 1984).	38
Figure 19: Principle of mass-spring system (Rao, 2005)	40
Figure 20: Dynamic amplification factor (Rao, 2005).....	43
Figure 21: Roll (Rawson and Tupper, 2001b).....	44
Figure 22: Heaving (Rawson and Tupper, 2001b).....	47
Figure 23: Roll added inertia, m_{A_roll} , for prismatic barge (Brown & Root Vickers, 1990). ..	50
Figure 24: Pitch added inertia, m_{A_pitch} , for prismatic barges (Brown & Root Vickers, 1990)	51
Figure 25: Heave added mass, m_{A_heave} , for prismatic barges (Brown & Root Vickers, 1990)	52
.....	52
Figure 26: Wave Spectrum (Phelps, 1995)	56
Figure 27: Response amplitude operators in heave, roll and sway for a barge.....	61
Figure 28: Intact stability requirement (DNV pt 1 ch. 2, 1996).....	70
Figure 29: Damage stability requirement (DNV pt. 1 ch. 2, 1996).....	71
Figure 30: Location of modules on barge	76
Figure 31: Model of the barge with guiding geometry	77
Figure 32: The barge with compartments	78
Figure 33: Load case 1, wet surface	79
Figure 34: Load case 6, one of the compartments.....	79
Figure 35: The barge model with mesh.....	80
Figure 36: Model barge with cargo	80
Figure 37: wave spectra.....	82
Figure 38: GZ-curve for intact stability	85
Figure 39: GZ-curve for damaged stability, two tanks.	86
Figure 40: A general overview of the ballast tanks.....	A-1
Figure 41: Four different hydro models (DNV, 2005b).....	B-4
Figure 42: Defintion of the phase bewteen the response and the incident wave (DNV, 2005b)	B-8
.....	B-8
Figure 43: Amplitude of response variables in heave	C-11

Figure 44: Amplitude of response variables in pitch	C-12
Figure 45: Amplitude of response variables in roll.....	C-13
Figure 46: Amplitude of response variables in surge.....	C-14
Figure 47: Amplitude of response variables in sway	C-15
Figure 48: Wave spectrum for a significant wave height of 6,7 m and with a varying zero up-crossing period, $6,5 \text{ s} < T_z < 11,5 \text{ s}$	C-16
Figure 49: Response spectrum heave for $T_z=6,5 \text{ s}$ and $T_z=7,5\text{s}$, and $H_s=6,5\text{m}$	C-17
Figure 50: Response spectrum heave for $T_z=8,5 \text{ s}$ and $T_z=9,5\text{s}$, and $H_s=6,5\text{m}$	C-18
Figure 51: Response spectrum heave for $T_z=10,5 \text{ s}$ and $T_z=11,5\text{s}$, and $H_s=6,5\text{m}$	C-19
Figure 52: Response spectrum roll for $6,5 \text{ s} < T_z < 11,5 \text{ s}$, and $H_s=6,5\text{m}$	C-20
Figure 53 Response spectrum pitch for $6,5 \text{ s} < T_z < 11,5 \text{ s}$, and $H_s=6,5\text{m}$	C-21
Figure 54: Response spectrum sway for $6,5 \text{ s} < T_z < 11,5 \text{ s}$, and $H_s=6,5\text{m}$	C-22
Figure 55: Response spectrum surge for $6,5 \text{ s} < T_z < 11,5 \text{ s}$, and $H_s=6,5\text{m}$	C-23
Figure 56: Response spectrum for acceleration in heave for $T_z=6,5 \text{ s}$ and $T_z=7,5 \text{ s}$ and $H_s=6,7\text{m}$	C-24
Figure 57: Response spectrum for acceleration in heave for $T_z=8,5 \text{ s}$ and $T_z=9,5 \text{ s}$ and $H_s=6,7\text{m}$	C-25
Figure 58: Response spectrum for acceleration in heave for $T_z=10,5 \text{ s}$ and $T_z=11,5 \text{ s}$ and $H_s=6,7\text{m}$	C-26
Figure 59: Response spectrum for acceleration in roll for $6,5 \text{ s} < T_z < 11,5 \text{ s}$ and $H_s=6,7\text{m}$..	C-27
Figure 60: Response spectrum for acceleration in pitch for $6,5 \text{ s} < T_z < 11,5 \text{ s}$ and $H_s=6,7\text{m}$	C-28
Figure 61: Response spectrum for acceleration in sway for $6,5 \text{ s} < T_z < 11,5 \text{ s}$ and $H_s=6,7\text{m}$	C-29
Figure 62: Response spectrum for acceleration in surge for $6,5 \text{ s} < T_z < 11,5 \text{ s}$ and $H_s=6,7\text{m}$	C-30
Figure 63: Response spectrum for accelerations in x, y and z-direction for Bridge 6 and 7, $H_s=6,7 \text{ m}$ and $T_z=6,5\text{s}$	C-31
Figure 64: Response spectrum for accelerations in x, y and z-direction for Bridge 8 and 9, $H_s=6,7 \text{ m}$ and $T_z=6,5\text{s}$	C-32
Figure 65: Response spectrum for accelerations in x, y and z-direction for WP Tower North and South, $H_s=6,7 \text{ m}$ and $T_z=6,5\text{s}$	C-33

List of tables

Table 1: α -values for significant wave heights (DNV, 1996 Table 3.1).....	67
Table 2: Summary of criteria for the stability of the barge.....	74
Table 3: Barge data	75
Table 4: Cargo data	76
Table 5: Loading condition	85
Table 6: Maximum accelerations at the center of gravity of the barge with cargo.....	86
Table 7: Maximum acceleration in x, y and z-direction for combined motions	87
Table 8: Maximum motions at the centre of gravity of the barge with cargo.....	87
Table 9: Roll and pitch motion compared to the simplified criteria given by Noble Denton (2005)	88
Table 10: Conclusion draught and trim, intact stability	90
Table 11: Conclusions draught and trim, damaged stability	90
Table 12: The ballast configuration	A-2

Nomenclatur

Δ – Mass displacement [kg]

∇ – Volume displacement [m^3]

β – the frequency ratio between wave frequency and natural frequencies of the barge, $\frac{\omega}{\omega_{0_i}}$.

ρ – density of sea water [$\frac{kg}{m^3}$].

ϕ – heel angle [deg]

ϕ_r – Angular displacement to the vertical for roll [rad]

$\dot{\phi}_r$ – Angular velocity for roll [rad/s]

$\ddot{\phi}_r$ – Angular acceleration for roll [rad/s²]

ϕ_p – Angular displacement to the vertical for pitch [rad]

$\dot{\phi}_p$ – Angular velocity for pitch [rad/s]

$\ddot{\phi}_p$ – Angular acceleration for pitch [rad/s²]

ϕ_{0_r} – Amplitude for the roll motion [rad]

ϕ_{0_p} – Amplitude for the pitch motion [rad]

ω_{0_h} – Natural frequency of heave [$\frac{1}{s}$]

ω_{0_p} – Natural frequency of pitch [$\frac{1}{s}$]

ω_{0_r} – Natural frequency of roll [$\frac{1}{s}$]

ω_e – encounter frequency of incident wave [$\frac{1}{s}$]

ψ – heading angle between the vessel's direction and the direction of the waves.

ζ – Amplitude of a regular wave

ξ – damping ratio

A_w – water line area of the barge [m^2]

B – Centre of buoyancy

B_0 – Centre of buoyancy before heeling.

B_1 – Centre of buoyancy after heeling.

\overline{BM} – Distance between centre of buoyancy and meta centre. Called metacentric radius. [m]

c – Damping constant

D – Draught [m]

G – Centre of gravity

g – Gravitation. [$\frac{m}{s^2}$]

\overline{GM}_T – Transverse metacentric height [m]

\overline{GM}_L – Longitudinal metacentric height [m]

\overline{GZ} – the arm of the righting moment [m]

$|H_{r\zeta}(\omega_e)|$ - Response amplitude operator, RAO. Also called transfer function.

$H_{1/3}$ – significant wave height, average height of the third highest waves in an irregular wave pattern. [m]

H – Wave height [m]

H_m – Most probable wave height [m]

I_x – The moment of inertia around the x-axis. [m^3]

K – The lowest part on the vessel, called the keel.

k – Spring constant

\overline{KB} – Distance between keel and centre of buoyancy. [m]

\overline{KG} – Distance between keel and centre of gravity. [m]

l_p – distance from centre of pitch to the point of interest [m]

l_r – distance from centre of roll to the point of interest [m]

M – Meta centre

m – mass [kg]

m_{A_heave} – added mass contribution in heave

m_{A_roll} – added mass contribution in roll

m_{A_pitch} – added mass contribution in pitch

m_j – spectrum moments

M_r – Righting moment caused by the force couple from gravity and buoyancy. [Nm]

M_k – External moment causing the barge to heel or trim. [Nm]

R – The intersection between a horizontal line through B_0 and the vertical line going through B_1 when the vessel is heeling.

r_x – radius of gyration with the x-axis. [m]

r_y – radius of gyration with the y-axis. [m]

$S_\zeta(\omega)$ - Spectral ordinate of a wave spectrum [$m^2 \cdot s$]

$S_r(\omega)$ - Spectral ordinate of a ship response system [$m^2 \cdot s$]

SPC – wave spectra

T_h – Natural period for the heave motion, included added mass [s]

T_p – Natural period for the pitch motion, included added mass [s]

T_r – Natural period for the roll motion, included added mass [s]

T_{h_air} – Natural period in air for the heave motion [s]

T_{p_air} – Natural period in air for the pitch motion [s]

T_{r_air} – Natural period in air for the roll motion [s]

T_z – zero up-crossing period [s]

W – Gravity force, given by mg [N]

X_s – Significant response

Z – The intersection between a horizontal line through G and the vertical line going through B when the vessel is heeling.

z – Position of the vessel according to the water line. [m]

\dot{z} - Velocity of the vessel in heave motion [$\frac{m}{s}$]

\ddot{z} - Acceleration of the vessel in heave motion [$\frac{m}{s^2}$]

z_0 – Amplitude for the heave motion [m]

1. Introduction

Transportation of large structures offshore is a common task for offshore engineers. When the cargo is too large for a supply ship, the use of a barge is a well known technology. It may seem like using this technique is a simple manoeuvre, but there are several conditions which have to be considered. Often the cargo is valuable, and in some cases there are also personnel onboard the barge. Accidents due to bad planning could therefore lead to tragedy or at least substantial loss.

1.1. Historical overview

There has been transportation along and across the water for ages. The barge has been used and developed over many years. Actually, one of the eldest remains of a barge found is estimated to be around 2000 years old. This barge was probably used by Romans in one of their northern territories near the German riverside city of Cologne. It is estimated to be around 2000 years old and is believed to have been approximately 23 metres long with a beam of 3,5 metres. The loading capacity is estimated to have been around 20-30 tons¹.

Barges developed in design throughout the 19th century and began to be built in standard sizes after the introduction of steamboats that allowed them to be towed easily.

There are further examples of barges used in wars all around the world. The well-known D-day is a good example. The allies used their self-powered transport barges to freight soldiers over the sea and disembark on the shores of Normandy.

Before the world wars and even today it is more common to think of the barges as canal freighters. Some of them are self-powered while others need to be tugged through the canals or rivers. Before the steam engine made its appearance it was normally horses that dragged them, but when floating tug boats equipped with strong engines were introduced, the use of horses was more or less discarded.

¹ Internet reference: 1

By the mid 1940's, William A. Bisso Sr. began to venture offshore using steam powered derrick barges to install some of the earliest offshore facilities in the Gulf of Mexico. What Bisso did not know was the popularity the barge was going to gain in the offshore business in the coming years.

Later the use of barges has been rather problematic in some wave conditions due to their unfavourable natural period. The problem is large when the wave period is approaching one of the natural periods of the barge. Some areas have larger difficulties than other. Probably the first barge was planned for the Mexican Gulf. The wave conditions here are rather mild, and we have therefore small problems with avoiding the barge's natural periods. When developing fields in the North Sea the standard offshore barges were used, but the wave conditions there are different and the wave periods match the periods of the barge more often.

1.2. Study objectives

The objective of this report is to underline the most important analyses used when planning for transportation with barges. These analyses will be used in a case study at the end where the main target is to decide the stability and the acceleration due to ship motion.

It will make use of theories regarding stability and hydrodynamic responses. When doing so we will look at the three transporting phases and the discussion of them. The three phases include:

- on-loading
- transport
- off-loading

Further on there will be a discussion of the criteria suggested by the standards used in the offshore business. The requirements of Det Norske Veritas (DNV, 1996) and Noble Denton (2005) will be included in this argumentation.

When looking into the theoretical approaches the report will try to present a good understanding of the theories used. As mentioned earlier the hydrostatic principle will be used when analyzing the barge's main stability. When looking at the barge's motions there will be

a quick glance at typical environmental conditions with emphasize on the waves. There will also be a short walkthrough of the most common wave theories used through the years. Then it is time to look at the motions of the barge in its six degrees of freedom. First of all the report will make account of the prime theories used in analysing transportation, and discuss some problem areas within these theories. Then there will be an overview of the tools used in the analysis.

The case study will look at a barge transport of 4 bridges and 2 towers. The stability and the motion response will be analysed and compared with the criteria given by DNV (1996) and Noble Denton (2005).

2. State of art

There are several methods that can be considered when transportation offshore is under planning. Small cargos are often lifted onboard supply ships and thereby freighted to the location. This is the normal transport method, but it is not possible with larger cargos. Then it is more common to either use the deck of a specialized ship, like a heavy lifter, or use a barge.

The use of a heavy lifter is expensive and it is only used when the cargo is so big and heavy that few other methods are possible or the transport is made over great distances. Examples are the moving of whole semi-submersible platforms, see Figure 1. Some of them are built in Asia and transported, to for example the North Sea, by heavy lifters.

When the cargo is too large for a supply ship and is regarded to be too small for a heavy lifter, the use of a barge is a good alternative. These floating structures can be found in many sizes, but the standard North Sea barge is approximately 100 metres long and has a 30 metres beam width. It is obvious that the most favourable property is its large deck area. Large structures can be handled by the offshore barges. The flat-bottomed floating freighter has been used for a lot of large transports like heavy modules and big steel jackets.

If the cargo requires special equipment for lifting during offloading, a crane vessel can be used. These specialized vessels have large cranes to handle heavy weight, and are also built to withstand the most common wave periods. A large deck make this alternative also suitable for transport, but the high rent costs make them expensive for operations where a barge can be used.

There is also a possibility to combine the two last methods. A barge is then used in sheltered waters; the cargo is lifted onto the deck of the vessel before reaching the harsher sea condition. It is also possible to transport this way if the sheltered waters are unsuitable for larger vessels, either because of the depth or narrow paths inland.

2.1. Barge vs. supply ship

The first and most important difference between transport on a barge or on a supply ship is, as mentioned earlier, the space and capacity. A barge has a larger deck and a larger capacity to

transport heavy and big cargo. The costs of using a supply ship for transport are rather small compared to the costs of renting and planning a barge transport. The ship is also faster and thereby a smaller weather window is needed. When looking into the weather problem it is certain that a barge do not have the same capabilities as a ship in rough weather. The ship will most certainly have a more favourable natural period.

It is often necessary to book a place on the supply boat a long time in advance. This is due to other assignments, therefore it may be more convenient to choose a barge even for smaller items.

2.2. Barge vs. heavy lifter

When choosing a heavy lifter rather than a barge, it is first of all the size and weight that matters. The heavy lifter has a very large capacity and can handle large structures. This specialized ship is categorized by its capability to submerge its large open deck to well below the water's surface, thus allow another vessel to be floated over it and on the top of the lifters deck. The heavy lift ship then rises out of the water by pumping out water from its ballast tanks. The transported vessel thereafter is transported to the desired location on top of the heavy lifters deck. Figure 1 shows the ship *Mighty Servant* when transporting a large semi-submersible platform.



Figure 1: Mighty Servant transporting an offshore platform

Another ship which also can be categorized as a heavy lifter is the crane ship. This vessel is

specially designed and capable of loading and unloading heavy and bulky items. The crane ships are designed to off-load cargo from non self-sustaining cargo ships or barges; in most cases it has also a deck capable of transporting cargo.

The costs of renting a barge compared to a heavy lifter are rather small, but the estimated transport time is higher. Thereby a larger weather window will be needed and the costs may level out.

At the end it is a question of not to overdo the transportation costs. A heavy lifter is probably not necessary for a transport over short distance or for not so heavy weights.

2.3. Barge selection and availability

Several considerations will have to be made before selecting a transportation barge. According to Noble Denton (2005) these areas of consideration are important:

- Is there adequate deck space for all the cargo items planned, including room for sea fastenings, access between cargo items, access to towing and emergency equipment, access to tank manholes, installation of cargo protection breakwaters if needed, and for lifting offshore if required?
- Has the barge or vessel adequate intact and damage stability with the cargo and ballast as planned?
- Does the barge or vessel as loaded have sufficient freeboard to give reasonable protection to the cargo?
- Is the deck strength adequate, including stiffeners, frame and bulkhead spacing and capacity, for loadout and transportation loads?
- For a barge, is it properly equipped with main and emergency towing connections, recovery gear, pumping equipment, mooring equipment, anchors, lighting and access ladders?
- Will the motion responses as calculated cause overstress on the cargo?

-
- Are all required equipment and machinery in sound condition and operating correctly?

Other more obvious considerations are given by Brown & Root Vickers (1990):

- Has the barge sufficient deadweight capacity to carry the weight from the cargo?
- Are the barge beam and length sufficient to prevent excessive overhang to prevent slamming? Also, too small a barge may result in excessive barge accelerations.
- Is the barge suitable for on-loading and off-loading of cargo? See Chapter 3.
- Is the required barge available at the time of the proposed transportation?

It is often necessary to make a compromise between stability and motion criteria. This is because wide barges have superior stability, but more severe motions compared to narrow beam barges.

When the required barge has been selected, shipbrokers must be contacted to check the availability. Such brokers are intermediaries between ship owners and charterers who use ships, or in this case barges, to transport cargo. Jon. I. Stie Shipbrokers and Fearnley Offshore are examples of such brokers.

When ordering a barge it is important to make demands regarding classification of the vessel. The broker should get the demanded classification and also order a check for damages by a warranty surveyor. It is also common that the broker makes the barge ready for transport regarding equipment and other necessities.

2.4. Classification

Classification of vessels is, according to the Norwegian ministry of justice and the police (NOU, 2000), a private and volunteer system which should provide that a ship/barge fulfils a set of security requirements given by a class society. An example of a company in the class society is Det Norske Veritas (DNV). Their common tasks during the building phase are to survey the operation and make sure that the drawings they have certified and the class limitations are being fulfilled. When the vessel is ready for the operational phase the task reduces to inspections now and then to make sure that the required maintenance is being

accomplished.

Classification is in principle volunteer, but insurance companies demand that the vessel is classified before it can be insured. Thereby classing becomes rather mandatory.

Common class limitations set requirements regarding both stability and accelerations from motion in six degrees of freedom. A more complementary listing of required demands is made in Chapter 5.

There are also class limitations for different operations. DNV (1996) and Noble Denton (2005) are companies that have given guidelines and requirements for towing. These guiding principles help inexperienced as well as experienced personnel to perform secure and effective operations. It also secures that the operations are done between secure outlines and that the companies performing the operations follow the best practice available, the so-called state of art.

3. Transport phases

An operation like transportation of cargo offshore could be divided into three main areas. The first can be named on-loading to the barge, the next one is the main transport phase and the last one is the off-loading. Several considerations have to be taken care of in each phase. This chapter looks at some of these considerations, and make a discussion where this is appropriate.

3.1. On-loading of cargo

Chapter 2 talked about the options available when choosing transportation method, whether supply ship, barge or heavy lifter is the most convenient method. Here it is assumed that a barge is chosen, but there will be different available methods within the barge concept. Ballast and grillage are also two important areas to address when analysing the on-loading of cargo.

Principle means of getting the cargo onto the barge are RO/RO (roll on, roll off), LO/LO (lift on, lift off), FLO/FLO (float on, float off) and skidding (Macswen, 2004). Small cargos are often handled by the LO/LO-method while heavier cargos usually use the more specialized methods. When transporting to offshore platforms, LO/LO may be the only possible method. While some times the best method is a combination of the methods. Today skidding is the most used method for on-loading to a barge for offshore transportation.

3.1.1. Roll on, Roll off

The principle of a RO/RO-vessel is that the cargo can be rolled on and off. The simplest example of this is the car ferry. The cars are considered as the cargo. Heavy lift cargos use hydraulic trailers either self powered or towed to establish the roll effect. The ballast tanks should be filled up according to the ongoing loading. This will ensure that the vessel have a required stability. Figure 2 shows a roll on operation using hydraulic axles.



Figure 2: Roll on to barge using hydraulic axles. (Macsween, 2004)

3.1.2. Lift on, lift off

The lifting of cargo on to and from a vessel can be achieved either by shore side craneage or using the vessel's own gear if fitted. A platform craneage may be used for an operation including lift off to an installation offshore. If the cargo is too heavy for the platform lifting equipment, the vessel has to have its own lifting gear, and then a crane ship may need to assist in the off-loading phase.

When loading out using the shore side craneage, the first task is to identify the capacity required and to select a suitable crane for the operation.

3.1.3. Float on, float off

When the cargo is a self-floating object of considerable size and does not lend itself to a feasible long distance wet towage, then the options for shipping via a semi-submersible vessel is a viable option. Examples of such objects are jack-up rigs, semi-submersible drill-rigs and pre-loaded cargo barges.

These semi-submersible vessels come in a variety of sizes and shapes. It is common to categorize them into two principle categories. The categories represent the vessel's capability to submerge parallel or inclined to the water surface. It's not only ships like heavy lifters which have this semi-submersible capability. Barges can also be built with flotation tanks and

thereby use the FLO/FLO-principle.

Vessels with a single buoyancy tower at one end will be submerged with an angle of trim. This is done to maintain stability. In many cases it is also possible to place the stern on the seabed before submerging completely leaving only a small tower section, containing vents to the pump room, above the water surface. Cargo is then floated over and the vessel starts the process of emptying the ballast tanks and starts floating.

For vessels which require to submerge with the deck horizontally it will be necessary to have flotation tanks in both ends.

3.1.4. Skidding

Skidding of cargo onto a transportation vessel is a conventional method which also is cost effective as compared to the use of expensive hydraulic axles. The cargo is moved over the quay edge with the use of low profile beams and skid shoes; it is obvious that a low friction surface between the two is important.

While the cost perspective is a pro for the skidding method, the time aspect is a certain pro for the hydraulic axles principle. The skidding is a method which requires great emphasis on the ballasting operation to ensure that a high degree of control over the levels between the barge deck and the quayside is maintained at all times. It is also important to maintain the trim as level as possible. By this it is possible to see that by using RO/RO-method far more generous tolerances are permitted. Figure 3 shows a large module being skidded onto a barge.



Figure 3: Skidding of a topside module to cargo barge. (Macswen, 2004)

It is common to let the barge use the short side into the quay edge when loading it. This makes the whole process more stiff and stable, and it is also easier to see the barge's responses due to the weight from the object. But this way it will also be need of long mooring lines behind the barge. If there is no room for this mooring it is possible to use the long side into the quay. The process will then go quicker and there is less time to do changes if something happens in another way then planned. It is also interesting to see the emptying of ballast tanks in Figure 3. This is an important and difficult part of the operation.

3.1.5. Combinations

Combinations of the methods mentioned are applicable. Skidding and lifting are often used together. The object transported will first get skidded onto the barge, and then transported to the desired destination. That could either be on the platform or in a sheltered area to get lifted onto a heavy lifter for the last transport and installation on the field.

3.1.6. Ballast

Ballast can be defined as heavy substances carried by a vessel for ensuring proper stability, so as to avoid capsizing and to secure effective propulsion². Sea water ballast is commonly

² Internet reference 2

located in ballast tanks, positioned in compartments right at the bottom and in some cases on the sides, called wing tanks.

For a barge case, sea water is the most common ballast. RO/RO and skidding are two methods where the ballast capability has to be used during the on-loading operation. It takes some time before the cargo's centre of gravity (COG) is placed at the right location. The ballast tanks are used to maintain stability when most of the weight is at an unfavourable place during on-loading. It is important to avoid large moments in the barge during load-out. That may happen early in the skidding process, when there will be ballast only in the tanks aft on the barge. It could then be more convenient to let the barge go deeper in the water and also use some of the tanks in the middle. This will reduce the moment and thereby reduce the risk of damage to the barge.

The ballast used when the load-out are finished should be approximately the same as the ballast used in transportation. This is due to the seafastening. It is not favourable to weld the seafastening and then change the ballast configuration. If this is done there could be damages to the welding due to movements in the barge during change in ballast.

The ballasting analysis is performed after the trim and stability analysis. The position of the cargo must also be specified first. To place the cargo the following information is important (Brown & Root Vickers, 1990):

- Distance from the cargo COG to the stern.
- Distance from barge deck to cargo COG.
- The behaviour of the cargo on the barge and in particular the rotation of the cargo axis system relative to the barge axis system.

The barge's lightship characteristics should also be determined. The areas of interest are:

- Lightship weight
- Longitudinal COG
- Transverse COG

-
- Vertical COG

Most barge owners have documentation stating these characteristics. Items excluded in the lightweight estimate should be included in the load statement as separate items. This include residual ballast, seafastenings, skid beams etc.

The loaded barge comprising of the lightweight loads, deck fittings and cargo should be ballasted in order to fulfil criteria from DNV (1996) or Noble Denton (2005), see Chapter 5.

3.1.7. Load out grillage

The cargo varies in shape and size which will lead to difficulties when placing it on the barge. The grillage makes sure that the loads from the cargo get distributed to strong points on the deck.

Factors influencing the load spreading grillage may include (Macswen, 2004):

- Support centres on the cargo
- Frame and bulkhead spacing on the transportation vessel
- Hatch cover construction and tie down
- Load out method

When designing the supporting arrangements the support centres on the cargo are important. These points may come in different forms, but it is important that they are identified and that any limitations are agreed on early in the design phase.

This implies that an optimal placing of the cargo is where the transverse framing and the support centres join up in a best possible way. Then the resulting load distribution into the barge structure is used as the basis for designing the strength of the supporting grillages. A grillage design can be as simple as bearing strips welded along the deck over the stiffening under deck, or it may be a set of custom plate girders fixed to the deck. Figure 4 shows an example of plate girder grillage.



Figure 4: Plate girder grillage (Macswen, 2004)

The weaker the barge deck is the more steelwork is required to distribute the support loads adequately into the strong points of the barge. The costs of this steelwork may be substantial; therefore the development of the barges has seen a substantial increase of the point load capacity. Figure 5 shows a number of typical cross sections from barges built between the 1970's and 2000.

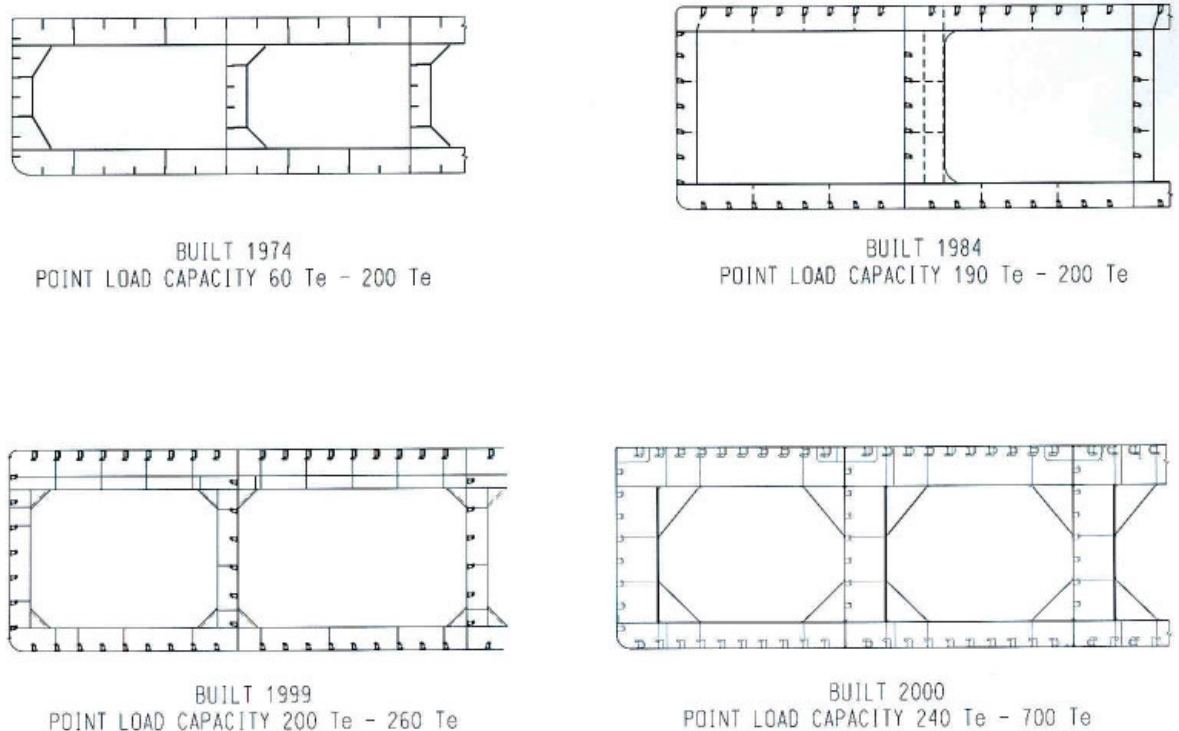

Figure 5: Development of barge cross sections from the 1970's to 2000. (Macswen, 2004)

The deck strength increases have been generally attained through several intensifications on

the frame and bulkheads.

3.2. The transport

After the loading on the barge is completed the tug boat can start the transportation of the barge to the desired destination. This phase includes several aspects where two of the most important are the stability and the motion areas. The motion leads to accelerations which will cause the need of seafastening to prevent damages to the barge or to the cargo itself. This chapter will have a more cursory explanation of the aspects mentioned. Chapter 4 will have a more thorough explanation of the theories behind the analyses.

3.2.1. Barge stability

Stability can be defined as the state or quality of being stable. If we look at a small floating body and that some force or moment causes a small change in its position, then we have three possible outcomes (Biran, 2003):

- The body returns to its initial position; the condition of equilibrium is stable.
- The position of the body continues to change. The equilibrium is unstable. This is the case when a ship capsizes.
- The body remains in the displaced position until the smallest perturbation causes it to return to the initial position or to continue to move away from the initial position. This is called neutral equilibrium.

A barge will have a possibility to move around the transverse axis, called longitudinal stability, and around an axis going through the length of the barge, called transverse stability. Several aspects have to be included in the stability analyses, but ballasting is one of the most important tools to achieve the stability needed. Ballast tanks are usually found in the bottom of the barge and will thereby work as a load below the centre of gravity. When using ballasting, it is important to check that the required freeboard is maintained.

DNV (1996) and Noble Denton (2005) have both requirements for the initial stability for an undamaged ship. There are also requirements in case of any damage to the ship.

3.2.1.1. Undamaged stability

Undamaged stability is also called intact stability or initial stability. Analyses of this aspect make sure the ship has a stable equilibrium and does not capsize when experiencing environmental loads like wind and waves. The principle is rather simple. The equilibrium of a floating body is stable if the metacentre is situated above the centre of gravity. A brief explanation of the definition of metacentre can be done by looking at two lines. The first one is the centre line which is the line where the buoyancy force acts before heeling. When the body heels, there will be a new line vertical through the centre of buoyancy which will be perpendicular to the waterline. Where these two lines cross each other as the heeling angle goes to zero we have the metacentre. Figure 12 in chapter 4.1.2.1 shows this principle.

3.2.1.2. Damaged stability

The stability also has to be analyzed with damaged compartments. The damage can be caused by collision, by grounding or by other accidents. A flooded compartment due to damage can cause a reduction in the stability. If this reduction becomes large enough, the ship may capsize. Even if the vessel does not capsize it may lead to an angle of heel or trim which may be dangerous for cargo and personnel. It is required that a barge which has suffered hull damage to an extent not larger than defined by pertinent regulations, should continue to float and be stable under moderate environmental conditions (Biran, 2003). Then personnel and cargo can be saved. Possibly the barge can be towed to a safe harbour as well.

3.2.2. Motions of the barge

When towing the barge in open sea it will get affected by the waves. These waves will make the barge move in its six degrees of freedom (DOF). These movements are rotational, which includes roll, yaw and pitch, and translational, which includes heave, sway and surge. Figure 6 shows each DOF.

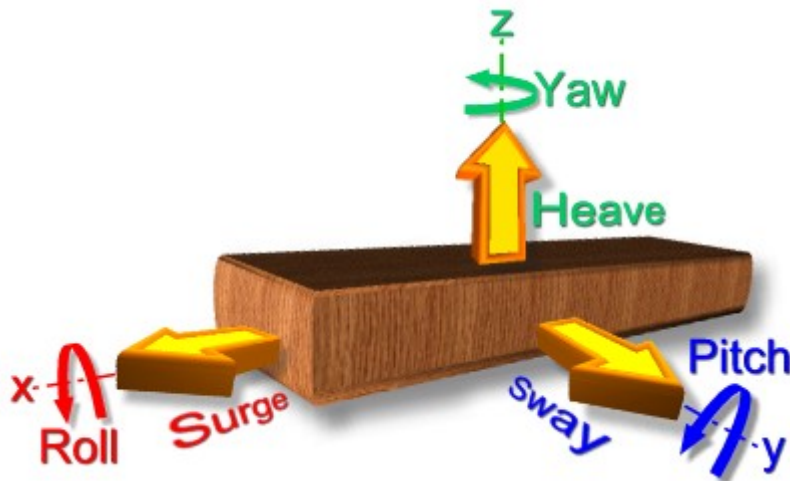

Figure 6: The six degrees of freedom.

Motion responses in each DOF can be found by model testing or by using computer programs.

3.2.2.1. Resonance

The barge will as mentioned be affected by the waves and will move with the waves, the excitation of the wave forces will give the barge an oscillation. This motion depends on wave size and period. If the wave period is approximately the same as one of the natural periods in one of the DOFs we will get large motions in this direction. Resonance is a phenomenon every marine engineer wants to avoid. Large amplitude oscillations reduce the performance of the crew and the equipment, and may be a danger to the cargo. Barges have rather unfavourable natural periods compared to waves in the North Sea, thereby it is important to study the weather forecasts and avoid days with wave periods close to the barge's natural periods.

Natural periods can change temporarily when a barge enters confined waters. The added masses, see Chapter 4.3.1.1 for further explanation on this phenomenon, are influenced by close vertical walls and by a close bottom.

Mass is an important part when calculating the natural period, thereby a change in added mass will give a change in natural period. Biran (2003) gives an example of a barge with a B/T ratio equal to 2. Here B is the maximum beam on the waterline, and T is the draft. When performing the roll test at a depth equal to $1,25T$, the added mass in roll was found to be 2,7 times larger than in deep waters. The measured roll period appeared larger than in deep

water. Wave conditions will also vary along the route of the transportation. The natural period of the DOFs should exceed these wave periods to avoid resonance motion. Further discussion of the natural period is given in Chapter 4.3.1.

3.2.2.2. Accelerations

When the barge gets a motion there will be acceleration. The larger the motion is, the larger the acceleration gets. From Newton's second law we have that a mass multiplied with acceleration gives a force. This force will be transferred to the cargo through the grillage and the seafastening. So a large acceleration will give a large force which the barge and the transported item have to withstand.

The derivation of the accelerations can be done through analysis of simple harmonic motions to more thorough numerical and physical tank testing of the loaded vessel.

3.2.2.3. Seafastening

Seafastening is made to ensure that cargo and the barge do not get damaged during towing. The motion responses and accelerations found either by model testing or by computer calculations are used to design the seafastening and the strength of it.

The range of seafastening solutions can be broadly sorted in groups like this (Macswen, 2004):

- Lashings, either wire or chain and tensioning devices such as turnbuckles or lever and hook tensioners. (Figure 7)
- Shear plates (Figure 8)
- Welded braces (Figure 9)

Use of lashings is a method used for small and intermediate sized cargo. It has been used for many years and is a very practical and useful method. However, it does run the risk of working loose during transportation due to the inherently cyclical nature of the loads acting on the cargo in a seaway. If this happen and the cargo starts to move slightly, then large impact loads may occur on the securing system and may result in catastrophic failure of the lashings and the cargo may eventually come free. Figure 7 shows an example of a typical

lashing arrangement.



Figure 7: Typical lashing arrangement. (Macsween, 2004)

If the cargo has suitable bearing and attachment points, then securing by shear plates offer a secure seafastening method.

It is important that these types of securings have a good alignment to the under deck structure. The welds between the web of the under deck stiffening and the deck plate should be carefully checked as these connections will transmit the loads. Figure 8 shows a simple example of a shear plate securing.



Figure 8: Simple shear plate securing. (Macswen, 2004)

More difficult items of cargo to handle are large items with a centre of gravity at a significant height above the deck. Braces are then an option commonly applied. This method supplies a restraint point of similar height or closer to the vertical centre of gravity and can reduce moments and uplift caused by accelerations of the barge.

The braces are connected to the cargo and the deck through profiled gussets designed specifically for each brace location. These gussets are placed on strong points of the cargo, and also connected in alignment with under deck stiffening. Bad alignment on the deck may cause local bending due to very high compressive loads carried by the brace. The bracing may be welded directly to the gussets, but it is also possible to use bolts. The gussets may be welded directly to the cargo, but it is also possible to bolt them to an existing interface.

Figure 9 gives an example of a bracing arrangement.



Figure 9: Example brace arrangement (Macswen, 2004)

3.2.2.4. Fatigue

Fatigue can be defined as an internal damage in the structure where contributions are accumulated from successive stress cycles (Gran, 1992). These stress cycles may be due to the impact of waves on the barge. Which may result in fatigue failure in the barge, but it is also possible that the forces from the waves make stress cycles on the cargo and thereby introduces fatigue problems in the cargo as well. The forces will be transmitted through the seafastening, so fatigue could also be a problem for this part.

The problem is large when slamming caused by waves occurs. This report will not explain this dilemma further, but it is important to be aware of it when analysing a barge structure, its cargo and its seafastening.

3.2.2.5. Motion damping

Some vessels have installed devices which purpose is to damp the motion of the vessel in a

desired DOF. Roll is the easiest DOF to damp and there are several methods which can be used. In principle, the methods used to stabilize against roll can be used to stabilize against pitch as well but, in general, the forces or powers involved are too great to justify their use (Rawson and Tupper, 2001b). The most used roll damping system for barges are bilge keels, see Figure 10.



Figure 10: Bilge keel

The other DOFs are more difficult to damp and the methods will not be introduced here.

3.2.2.6. Other considerations

Other considerations to discuss include, among others, tow route, weather monitoring, tow procedure and configuration and tug selection.

When deciding the tow route, the following factors should be considered (Brown & Root Vickers (1990) :

- Weather conditions
- Distance to ports of shelter
- Shallow or narrow waters
- Maximum tow speed
- Coastal tows
- Offshore structures

- Congested seaways

Weather monitoring is important, and reference is given to operational criteria given by DNV (1996) and Noble Denton (2005). The tow may not be executable if the weather conditions are harsh. When planning the operation the engineers have to find a period of time when there are acceptable weather conditions, this period is called the weather window. The window has to be large enough to make room for the whole operation.

Tug selection may make the needed weather window shorter because of the maximum tow speed. There are other factors included when selecting tug boat, this report will not make any further discussions regarding this topic.

3.3. Off-loading of cargo

The most common method to offload when using a barge is lifting. The platform crane or a crane ship may carry out the lift. In any case will there be several considerations for this phase as well. Many of the considerations or problems with lifting are caused by waves. So these problems could get minimized if the wave conditions are mild.

3.3.1. Resonance

The phenomenon of resonance has been mentioned earlier. It occurs when the wave periods are close to one of the natural periods of the barge DOFs. The amplitude will then be large and a lift off could be difficult to accomplish. This could result in delays for several days and thereby induce a huge economical cost. One of the most known examples of problems due to resonance is during the installation of the Kvitebjørn-platform deck. The swells were not too large, but the period was unfavourable compared to one of the natural periods of the barge. The first attempt of installing the deck was early April 2003, but the bad wave conditions made the installation difficult and it did not get installed before the 16th of May.

3.3.2. "second wave hit"

When lifting of a module or some other large object it would be convenient to do the lift off at the wave top. If the object is not lifted enough until the next wave top arrives, there could be a

collision load which could damage both the barge and the cargo.

4. Theoretical subjects

There are several areas which have to be considered when analysing transportation offshore. Two of the largest and most important subjects are the stability issue and calculations of the ship motions and its accelerations. A definition of the stability is given in Chapter 3.2.1. We can from this definition see that it is important to check that the barge have a condition of stable equilibrium before using it. The ship motion and its accelerations will give the forces which cargo, seafastening and barge has to withstand during transportation. This chapter will make a more thorough explanation of the theories used when analysing these two important subjects.

4.1. Buoyancy and stability

This chapter will, as mentioned earlier, include a more thorough explanation of buoyancy and stability. To do so it is convenient to simplify the problem by making some assumptions.

- the water is incompressible
- viscosity plays no role
- surface tension plays no role
- the water surface is plane

These assumptions can be done according to Biran (2003). The first assumption can be regarded as true. When it comes to viscosity it will be more difficult to make the assumption. It is exact in static conditions and a good approximation at very slow rates of motion. The third assumption is true for a certain size of floating bodies along with common wave heights. The last hypothesis, however, is never true. There will always be waves of different sizes at the water surface. However, when using this assumption we can derive general results and calculate essential properties of floating bodies.

4.1.1. Buoyancy: Archimedes' principle

Some objects placed in the water will float, some will sink, while others will neither float nor

sink. Those floating are called positively buoyant, those sinking are called negatively buoyant and at last the objects not sinking or floating are called neutrally buoyant³. The idea of flotation was first discovered by Archimedes which also gave his name to the phenomenon; Archimedes' principle.

A body partially or completely immersed in a fluid is buoyed up, or sustained, by a force equal to the weight of fluid displaced. (Gillmer and Johnson, 1982)

From this definition we can see that whether an object sinks or floats, is decided not only by its weight, but also the amount of water it displaces.

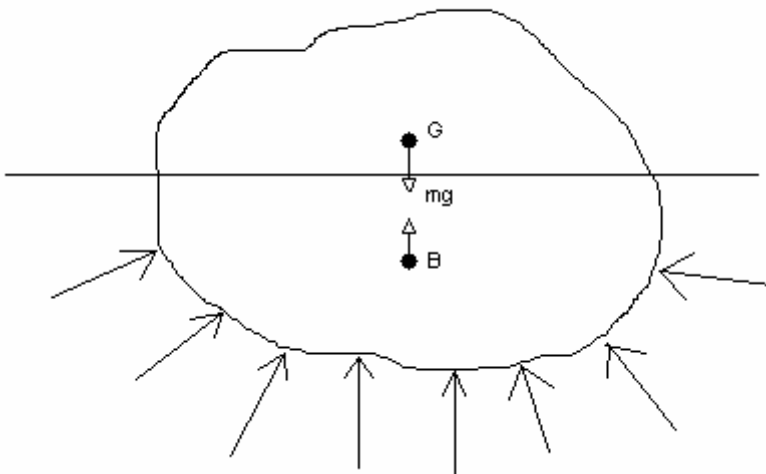

Figure 11: Floating body (Tupper, 2004)

From Tupper (2004) we can see that a floating body like the one in Figure 11 needs to have forces in opposing directions to remain in equilibrium. It is shown that the hydrostatic forces on the part of the body below the surface, acts perpendicular to the surface. These forces can be resolved into vertical and horizontal forces. While the horizontal forces are cancelling each other out from the opposing hydrostatic force, the vertical hydrostatic forces will be cancelled out by the gravitational force from the body's mass, mg . It is convenient to concentrate these vertical forces in two points; the gravitational forces are concentrated in the centre of mass, G , and the hydrostatic vertical forces are concentrated in the centre of buoyancy; B .

³ Internet reference: 3

4.1.2. Stability

The condition for a floating body to be in a situation of stable equilibrium is a requirement of no accelerations. Newton's second law says that this happens when the sum of all forces acting on the body and the sum of all moments of those forces are zero. It has been mentioned earlier that a body is in static equilibrium if it returns to its original position when disturbed by an outside force or moment.

We have two kinds of stability for a barge. We have what is called longitudinal stability which is stability around the transverse axis, and we have transverse stability, which is stability around the longitudinal axis. If the vessel floats totally horizontal we say that it floats without trim. Trim is measured in metres and describes the vessels rotation around the transverse axis.

4.1.2.1. Intact stability

It will be concentrated on small angles of inclination when explaining further. Even if the figures are of a transverse cross section of a vessel, the principle used will also be applicable to the longitudinal stability analyses.

When the floating body, for example a barge, is disturbed by an external force or moment (M_k) it will start to heel. Then the shape of the underwater body will be changed, which will move the position of the centre of buoyancy (B_0). The new centre of buoyancy is called B_1 . A point which may be called fake metacentre is shown in Figure 12, and is located where the vertical line through the new centre of buoyancy crosses the centre line, which is the line through the buoyancy centre before heeling. The distance between G and M (\overline{GM}) is called the Metacentric height and is a common term when discussing stability.

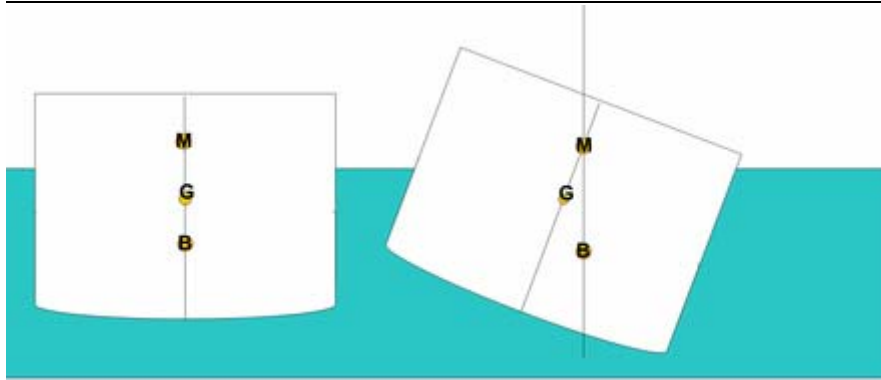

Figure 12: Fake metacentre and metacentric height

Gillmer and Johnson (1982) have given a good explanation of the relations between the metacentric height (\overline{GM}), the righting moment (M_r) and the stability.

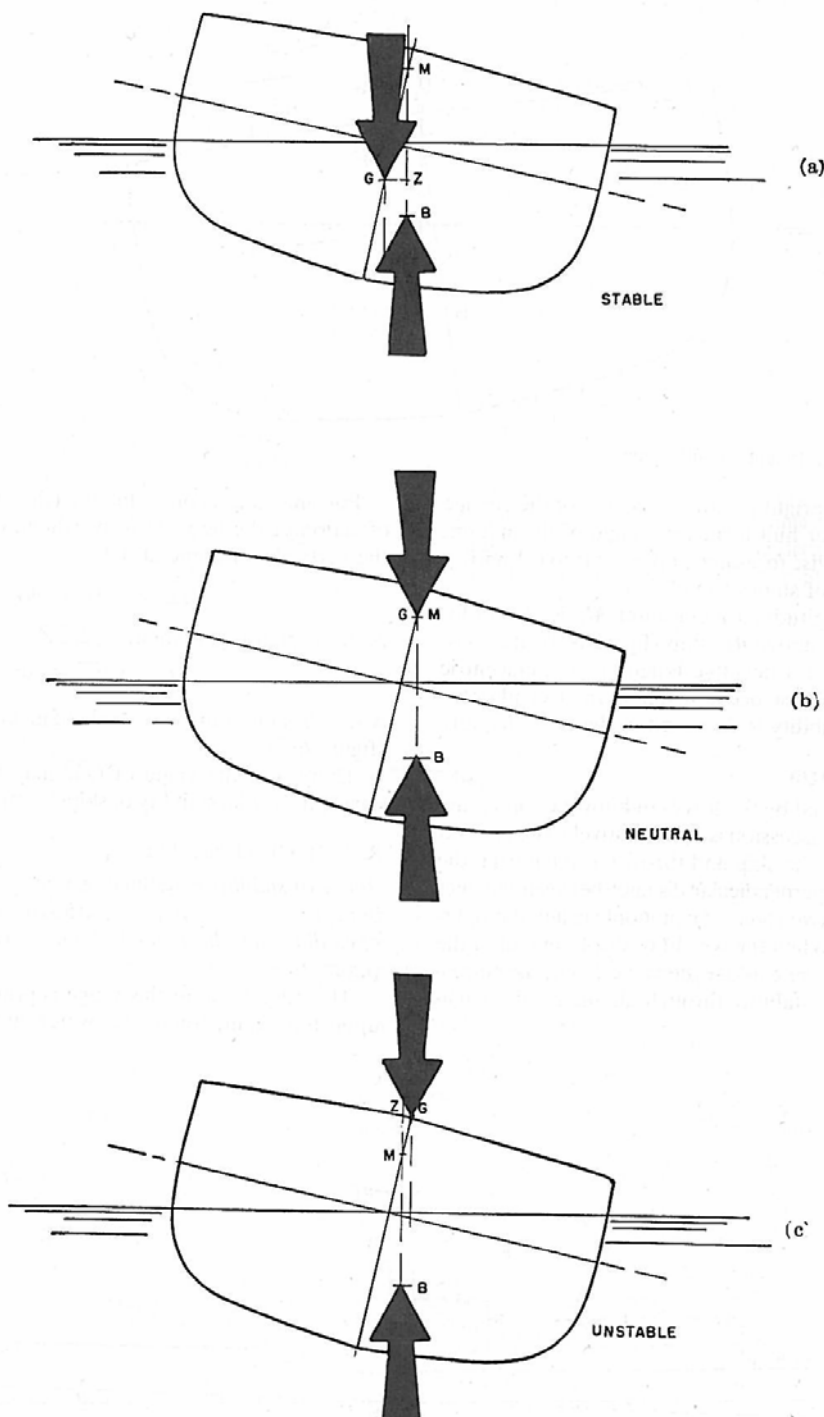

Figure 13: Stable (a), neutral (b), and unstable (c) equilibrium in the upright position. The hull is shown inclined by an outside force to demonstrate the tendency in each case. (Gillmer and Johnson, 1982)

Figure 13 shows the principle of stability to a ship. When the vessel is heeling there will be formed a force couple between the force of gravity and the force of buoyancy. This force couple will give a moment, M_r , which tends to upright the vessel if we have a condition of stable equilibrium (a), the moment arm is called a positive righting arm (\overline{GZ}). Suppose now

that the centre of gravity is moved upwards to such a position that when the ship is heeled slightly, the buoyancy force acts in a line through the centre of gravity. Then there are no unbalanced forces and the vessel has found a new equilibrium. It is in the condition of neutral equilibrium (b). If the centre of gravity is moved even further upwards the force couple will give a moment in the same direction as the inclination caused by the external force. Then the force couple will make the vessel to incline further. In this situation the ship has a negative \overline{GZ} (c).

M_r can be written as:

$$M_r = \Delta \overline{GM} \sin(\varphi) \quad 1$$

For small angles of inclination, $\sin(\varphi) \approx \varphi$, then we have

$$M_r = \Delta \overline{GM} \varphi \quad 2$$

The assumption of small angles and Figure 14 are used to calculate the metacentric radius ($\overline{B_0M}$), the distance from the keel to the centre of buoyancy ($\overline{KB_0}$) and the distance from the keel to the centre of gravity (\overline{KG}).

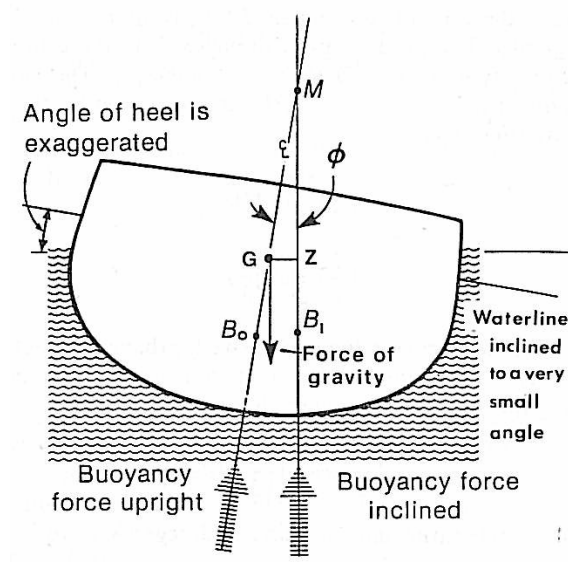

Figure 14: Terms used to calculate metacentric height (Gillmer and Johnson, 1982)

\overline{GM} may then be calculated from the following formula:

$$\overline{GM} = \overline{KB} + \overline{BM} - \overline{KG}$$

The height of \overline{GM} influences the general stability in the following way (Gudmestad, 2007).

- $\overline{GM} > 0 \rightarrow M_r > 0$: The ship will go back to its original position when the external influence is removed. It is in the state of stable equilibrium. (a)
- $\overline{GM} = 0 \rightarrow M_r = 0$: The ship is in a condition of neutral equilibrium. (b)
- $\overline{GM} < 0 \rightarrow M_r < 0$: The ship is in a condition of unstable equilibrium. It will continue to incline even if the external influence is removed. (c)

4.1.2.2. Stability at large angles of heel

The most desirable stability characteristics for ships are those that combine an adequate maximum righting arm at an adequate angle of inclination with a substantial range of stability (Gillmer and Johnson, 1982).

When a floating structure has a large inclination, for example more than 4 or 5 degrees, M can no longer be regarded as a fixed point. Then \overline{GM} is no longer a suitable measure of stability and the value of the righting arm, \overline{GZ} , is used instead (Tupper, 2004).

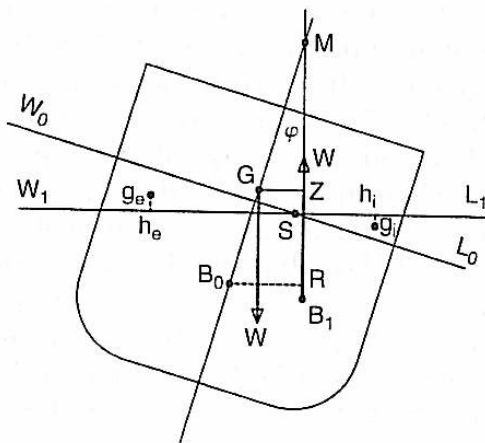

Figure 15: Explanation of symbols (Tupper, 2004)

\overline{GZ} can be found from Figure 15:

$$\overline{GZ} = \overline{B_0R} - \overline{B_0G} \sin(\varphi) \quad 4$$

A typical plot of a curve of \overline{GZ} against φ is given in Figure 16.

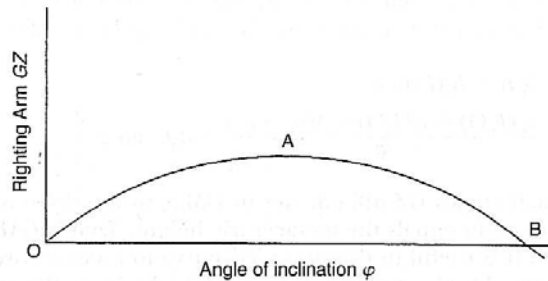

Figure 16: GZ-curve (Tupper, 2004)

The value of \overline{GZ} increases when the angle of heel increases. The maximum point, A, is the maximum righting arm. If the applied moment has an arm larger than the value in A, the vessel will capsize. When the angle of heel is larger than point B the vessel will have a condition of unstable equilibrium. The value of φ between O and B is termed the range of stability.

4.1.2.3. Free surface and the effect on stability

The ballast tanks are usually filled up with sea water. One of the purposes of the ballast is to lower the centre of gravity and thereby increase the metacentric height. When the compartments are completely filled, the liquid cannot move within the tank when the ship heels. So each compartment can be treated as static weights which affect the total centre of gravity as mentioned above.

If the tanks are partially filled, the liquids will flow to the low side of the tank which will make the centre of gravity of the tank to change position. This change in position will also affect the total centre of gravity which will make \overline{GM} smaller and thereby reduce the general stability.

4.1.2.4. Damaged stability

Damaged stability is a term which includes the vessel's stability if the hull gets damages. Accidents like grounding or collision may cause such damages. It is then important that the ship, or barge, have enough buoyancy and stability so the personnel and the cargo can get

rescued. To achieve good damage stability the hull is subdivided into several watertight compartments. The length of the compartments should be such that after the flooding of a certain number of adjacent compartments, the waterline shall not lie above a line prescribed by relevant regulations (Biran, 2003). The number of adjacent compartments which should be allowed to be flooded is decided by the same regulations. The size and the mission of the ship influence this number, but for most situations two compartments is prescribed. Which compartments to be used in the analysis should be decided by the worst case scenario, for a barge it will often be two compartments either in the front or in the back.

There are two ways of calculating the effect of flooding. One way is known as the method of lost buoyancy, the other as the method of added weight (Biran, 2003). In the first method it is assumed that a flooded compartment will no longer supply buoyancy. Biran (2003) continues his explanation by telling that we should imagine an open communication between a compartment and the surrounding water, the water inside the compartment will then exercise pressures equal to and opposed to those of the external water. The buoyancy proposed by the Archimedes' principle will then be cancelled by the weight of the flooding water. In this method the volume of the flooded compartment no longer belongs to the vessel. The weight of the structure will, however, not be changed. Then the vessel has to change position to re-establish the equilibrium, during this process the centre of gravity and the displacement remains constant. There will be no free surface effect of the flooded compartment, as the flooding water does not belong to the ship.

The method of added weight assumes that the water entering a damaged compartment belongs to the ship; this means that the mass needs to be added to the ship's displacement (Biran, 2003). So in this method, the displacement and the centre of gravity will change. In addition there will be a free surface effect. The displacement will be the sum of the intact displacement, while the centre of gravity can be obtained from the sums of the moments of the intact vessel and of the flooding water.

There should also be looked into the possibility of the vessel heeling such that parts of the deck are submerged. This may lead to further flooding and further sinking.

The conclusion of this sub-chapter is that if a vessel gets damaged and a number of compartments get flooded the metacentric height will be reduced and the righting moment

will decrease. This leads to a reduced overall stability.

4.2. Physical environment

It is important to understand the environmental conditions like waves, wind, currents etc., when planning an offshore transportation. By performing comprehensive investigations valuable information about the meteorological and oceanographical conditions can be obtained, the operation can then be planned thereafter. NORSOK (N-003) is also a valuable tool when working with environmental conditions in the North Sea. Here a lot of data is collected and these can be used to find extreme conditions with a certain possibility of exceedence.

4.2.1. Water and air

A barge operates on the interface between air and water. The density and the kinematic viscosity of water vary with salinity and temperature. The influence of the depth on these properties can be ignored because of the water being incompressible. When making analysis in air and water it is common to use standard values. This includes a mass density of fresh water of 1000 kg/m^3 and of sea water of 1025 kg/m^3 . For air at standard barometric pressure and temperature, with 70 per cent humidity, a mass of $1,28 \text{ kg/m}^3$ is used. (Tupper 2004)

4.2.2. Wind

Wind can make manoeuvring difficult when adding to resistance. Beam wind will also make a ship roll. The wind's influence on the sea state is decided by the wind's strength, its duration and the distance over where it acts, its fetch. When the waves have travelled outside the area where they are generated they are termed swells.

The strength of the wind is classified in broad terms by the Beaufort scale. The scale categorizes the wind speeds in 13 grades, varying from 0 to 12 where 12 is "hurricane" and has average speeds over $32,7 \text{ m/s}$ measured 10 m above sea level and 0 is "calm" and has speeds less than $0,3 \text{ m/s}$.

4.2.3. Wave theory

Waves are posing the greatest threat, and needs special attention. Not just because of their

influence, but also because of them being one of the most complex and changeable phenomena in nature (Goda 2000). The sea can change from being almost still to be affected by wind and gravity which may generate enormous “mountains” of water being several metres high. It is also complex to describe the waves by direction and size since they are built up by many sea states, see Figure 17. However, when the waves are reaching a beach we can see the swell breaks as individual waves. This gives an impression of a regular repetition.

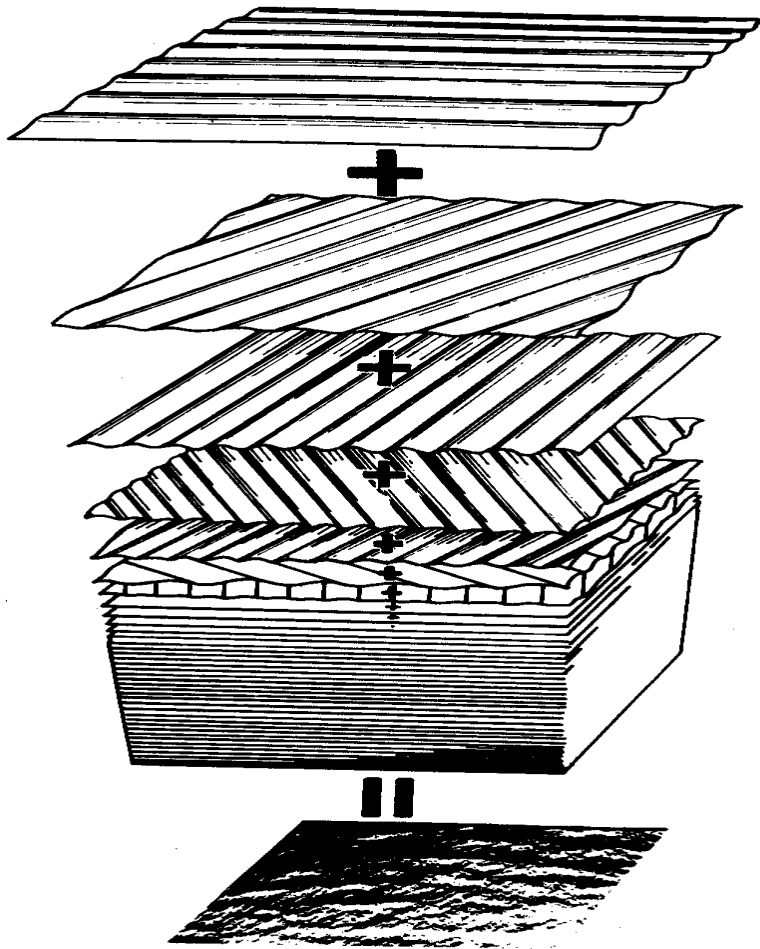

Figure 17: Wave Fourier composition (Ochi 1998)

Although the mathematical formulation of the motion of water waves was first introduced in the 19th century, there have been accomplished observations of the creation of waves, and their resultant propagation throughout history⁴. The historical overview starts in 1802 when Gerstner published the trochoidal wave theory for waves in deep water. The full range of

⁴ The following historical overview of the study of water waves is based on the literature listed by Lamb (1932).
Sindre Fjelde

water depths, from deep to shallow water, was first taken into account by small amplitude wave theory by Airy in 1844. Airy wave theory is the most used theory today because of being least mathematically complex. It is also known as the theory of linear waves.

There are several theories of nonlinear waves. Stokes gave in 1847 a theory of finite amplitude waves in deep water; this theory was later extended to waves in intermediate-depth water. This solution is now known as the Stokes wave theory. In the same year as Airy introduced his theory, Russell reported the existence of a solitary wave which has a single crest and propagates without change of form in shallow water. The theoretic description of such waves was given by Boussinesq in 1871 and by Rayleigh in 1876. It is called the solitary wave theory. Korteweg and de Vries derived in 1895 a theory of permanent periodic waves of finite amplitude in shallow water.

R. E. Froude was the first to understand the irregular behaviour of waves the way we do today. He postulated in 1905 that irregular wave systems are only a compound of a number of regular systems, individual waves of comparatively small amplitude, and covering a range of periods as shown in Figure 17. Further he stated that the effect of such a compound wave system on a ship would be *more or less the compound of the effects proper to individual units composing it*. This is now the basis for all modern studies of waves and ship motions (Tupper 2004).

Thus, the fundamental theories of water waves were established by the end of the 19th century. Nevertheless, it would take several years before civil engineers were able to make full use of these theories in engineering applications.

The theories were also revised and investigated further through the 20th century. Gerstner's trochoidal theory was not only studied by Stokes, but several others used his work as a link to finite amplitude wave theory. Among them were Levi-Cevita and Struik with two independent works in 1926 and Havelock in 1914.

Stokes theory becomes cumbersome and impractical for long waves of finite height. Russell's solitary wave theory is one of the alternative theories for this case. Munk published his revised version of the solitary theory in 1949. His work summarized Russell's earlier efforts and proposed a modification applicable for a problem Russell had with periodic waves.

With the availability of computers, along with parallel advances in numerical techniques and programming, there has been a natural development toward increased use of numerical wave theories. The programs used may be based on both deterministic and statistical descriptions of ocean waves.

It has been shown that the irregular waves that can be seen on the ocean are a compound of regular waves. To study the irregular sea state it is necessary to look at the individual wave components, which are regular, and combine them to get information regarding typical irregular seas.

4.2.3.1. Description of ocean waves

When describing ocean waves, there are two fundamentally different approaches. The first is called the deterministic approach, and the second is the probabilistic approach. Deterministic approaches are most useful in describing the short time-scale features, while the probabilistic approach is most useful for describing the long time-scale features of ocean waves. Figure 18 summarizes the two approaches and their methods.

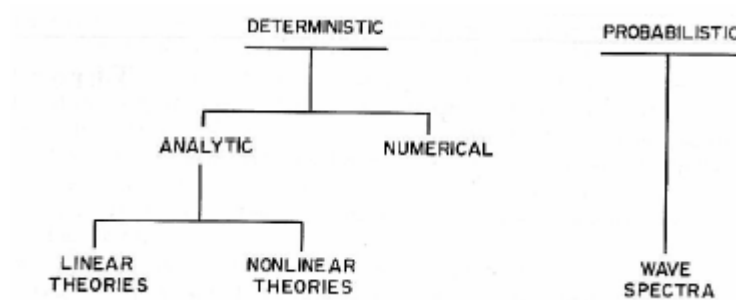

Figure 18: Alternative approaches for describing ocean waves (Wilson, 1984).

4.2.3.1.1. Deterministic approach

Linear theories, or earlier known as Airy's theory, are the most important of the classical theories because it forms the basis for the probabilistic spectral description of waves. But the linearization is not always good enough to describe the waves, often it is better to use methods based on nonlinear wave theories. The complexity becomes larger and therefore it is most common to simplify and use linear theories.

4.2.3.1.2. Probabilistic approach

The probabilistic approach uses a wave spectrum to describe the ocean waves. Like in figure xx, the sea waves can be analyzed by assuming that they consist of an infinite number of wavelets with different frequencies and directions. The distribution of the energy of these wavelets when plotted against the frequency and direction is called the wave spectrum (Goda, 2000). The wave energy distribution with respect to the frequency alone is called frequency spectrum. A more complementary explanation of the wave spectra is given in Chapter 4.3.5

4.3. Ship motions

The 6 DOFs of motions have been mentioned in Chapter 3.2.2. So there are translational motions like surge, sway and heave, and there are rotational motions like roll, pitch and yaw. Motions in any of these DOFs may coexist in a given short time period, one being superimposed on another, resulting in a complex motion that is difficult to describe. Due to this, studies are often made at a particular heading in which some of the DOFs are suppressed. For example are sway, roll and yaw suppressed in head seas, while beam seas produce primarily roll, heave and sway. The motions in any of the DOFs lead to forces on the vessel and the cargo onboard. The importance of minimizing any of them depends on the ship and the sea conditions in which she is expected to maintain operational capabilities (Gillmer and Johnson, 1982).

If it is looked further into the DOFs it can be seen that translations along the x- and y-axis, surge and sway respectively, and rotation about the z-axis, yaw, will not lead to any residual force or moment as the vessel is in neutral equilibrium. According to Rawson and Tupper (2001 a and b) is this statement true as long as the displacement remains constant. For the other translation and rotations, movement is opposed by a force or a moment provided the vessel is stable in that mode. The magnitude of the opposing force or moment will increase with increasing displacements from the equilibrium position, for small disturbances this variation will be linear.

What are explained in the section above are the characteristics of a simple spring system. Figure 19 shows an example of a translational spring system with damping. So the equations used in the problem with motion of a vessel in still water, which is subjected to a disturbance

in either heave, pitch or roll, will be similar to the ones used for motion of a mass on a spring.

Most of the sections in this chapter are strongly influenced by Rawson and Tupper (2001 b).

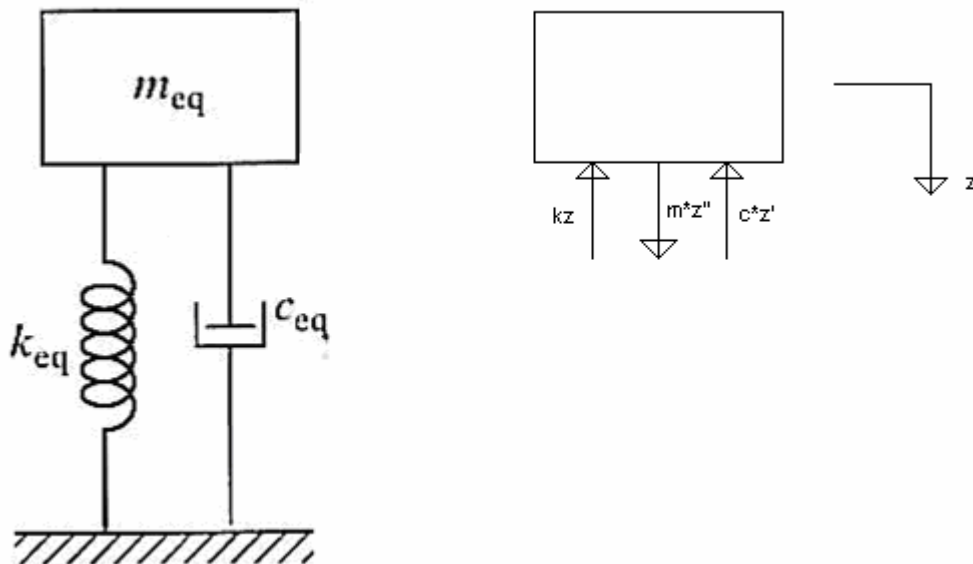

Figure 19: Principle of mass-spring system (Rao, 2005)

Disturbance in yaw, surge and sway will not lead to such an oscillatory motion. The next sections will deal with the oscillatory motions, damped and undamped, in still water. Later there will be an introduction to more realistic wave conditions.

4.3.1. Natural periods

Before the motion analysis is performed, the natural periods should be decided. Then it is possible to ensure that the response operators are well defined around the peak response, and it is also possible to identify potential resonance problems early in the analysis.

The natural period can be defined as the period a system oscillates with, when it vibrates on its own after an external disturbance (Rao, 2005).

In order to calculate the natural periods, it is necessary to find the stiffness and the effective or equivalent mass of the structure for each degree of freedom. The effective mass should include the mass of the structure and the added mass of the barge in a fluid.

4.3.1.1. Added mass

Added mass is the inertia added to a system because an accelerating or decelerating body must move some volume of surrounding fluid as it moves through it. For simplicity this can be modelled as some volume of fluid moving with the object.

Brennen (1982) uses the principle of energy to explain the phenomenon of added mass. In this principle the added mass determines the necessary work done to change the kinetic energy associated with the motion of fluid.

The added mass is different for each DOF.

4.3.1.2. Resonance

Resonance occurs, as earlier mentioned, when the wave period approaches one of the natural periods of the barge. The amplitude in this DOF will then be large and the barge and its cargo could get severe damage.

When looking into the resonance problem, it is common to look at a factor called dynamic amplification factor (DAF). This factor compares the wave period to the natural period and shows how big the amplitude of motions could get under certain conditions.

DAF is referred to in the case of a damped system under harmonic force. The equation of motion in air, i.e. without added mass, could then look like this:

$$m \cdot \ddot{z} + c \cdot \dot{z} + k \cdot z = F_0 \sin(\omega \cdot t) \quad 5$$

The solution would be a sum of one homogeneous solution and one particular solution. The particular solution is of special interest in this case and it will look like this:

$$z_p = z_0 \sin(\omega \cdot t - \phi) \quad 6$$

Where ϕ is the phase angle.

The amplitude of this particular solution is given by this equation:

$$z_0 = \frac{F_0}{m \cdot \omega_0^2} DAF = \frac{F_0}{k} DAF \quad 7$$

The DAF is given by:

$$DAF = \frac{1}{\sqrt{\left(1 - \frac{\omega^2}{\omega_0^2}\right)^2 + \left(2\xi \frac{\omega}{\omega_0}\right)^2}} \quad 8$$

Where

- ω_0 is the undamped natural frequency = $\sqrt{\frac{m}{k}}$
- ω is the wave frequency
- ξ is called the damping ratio and denotes how large the damping is compared to the critical damping . $\xi = \frac{c}{2 \cdot m \cdot \omega_0}$

It is common to show the variations of the DAF with the frequency ratio, $\beta = \frac{\omega}{\omega_0}$, and the damping ratio in a diagram like Figure 20.

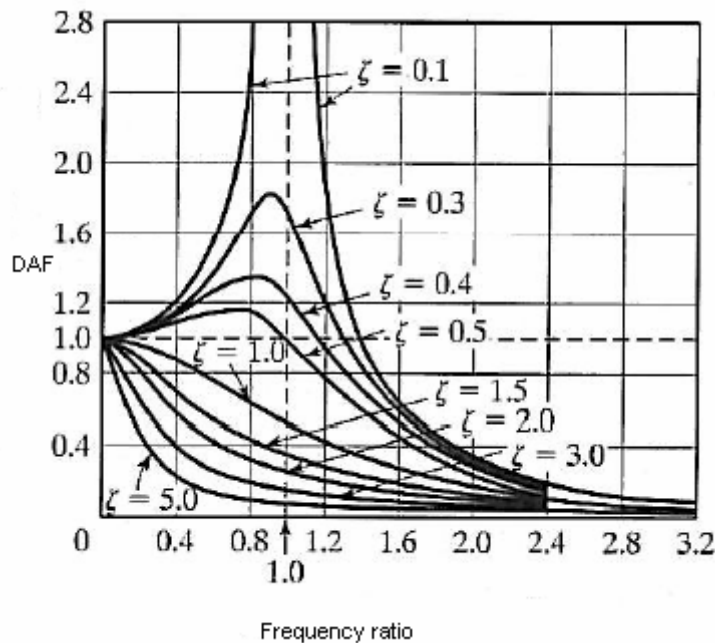

Figure 20: Dynamic amplification factor (Rao, 2005)

From Figure 20 it can be seen that when β approaches 1, the DAF will be high. It is possible to increase the damping effect and get smaller amplitude, but the area around 1 is unfavourable.

4.3.2. Natural periods: Undamped motion in still water

It is assumed that a vessel is floating freely in still water. A sudden force or moment disturbs the vessel. When this force or moment is removed, the three oscillatory motions (roll, pitch and heave) of the vessel will be studied. It is common to use data programs such as WADAM, which will be used in the case study. An introduction to the program can be found in Appendix B. The mass can, as mentioned, be divided in two, the structural mass and the added mass of the barge in the fluid. The added mass varies with the wave period so that the calculation of the natural period is a complex operation. Brown & Root Vickers (1990) have given a simplified method to determine the equivalent mass. The method is divided in two stages. The first stage is to calculate the natural periods in air, which means that the added mass term is neglected. When these values are obtained the added mass contribution in roll, pitch and heave can be determined from Figure 23 to Figure 25 (Brown & Root Vickers, 1990).

4.3.2.1. Natural periods excluded added mass

4.3.2.1.1. Roll

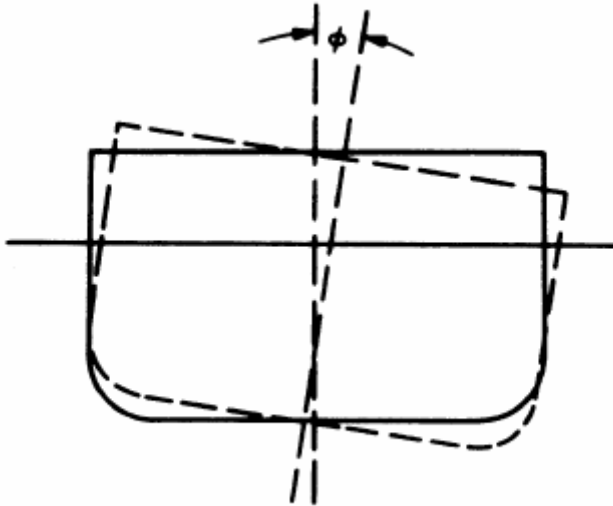

Figure 21: Roll (Rawson and Tupper, 2001b)

The equation of motion for an undamped rotational system like the roll of a vessel can be written like this:

$$I_x \ddot{\phi}_r + c \dot{\phi}_r + k \phi_r = M(t) \quad 9$$

Where

- $I_x = m \cdot r_x^2 = \frac{\Delta}{g} \cdot r_x^2$ - the moment of inertia around the x-axis.
 - o Δ is the mass displacement and is given by: $\Delta = m \cdot g$
 - o m is mass without added mass
- r_x is the mass radius of gyration given by: $r_x = \sqrt{\frac{I_x}{m}}$
- ϕ_r is the inclination of the vessel to the vertical, see Figure 21.
- c is the damping constant.

-
- k is the spring constant.
 - $M(t)$ is an external moment.
 - $k \cdot \varphi_r$ is another notation for the righting moment.

By using equation 1, $k \cdot \varphi_r$ can be expressed as:

$$k \cdot \varphi_r = \overline{\Delta GZ} = \overline{\Delta GM_T} \sin(\varphi_r) \quad 10$$

For small φ , k can be written as:

$$k = \overline{\Delta GM_T} \quad 11$$

By remembering that $c = M(t) = 0$ for an undamped free system, equation 9 becomes:

$$\frac{\Delta}{g} \cdot r_x^2 \cdot \ddot{\varphi}_r + \overline{\Delta GM_T} \varphi_r = 0 \quad 12$$

This can be simplified to

$$\ddot{\varphi}_r + \frac{g \cdot \overline{GM_T}}{r_x^2} \varphi_r = 0 \quad 13$$

Equation 13 can be recognized as the differential equation denoting simple harmonic motions with a solution for φ :

$$\varphi_r = \varphi_{0_r} \sin(\omega_{0_r} \cdot t) \quad 14$$

Where

- φ_{0_r} is the amplitude, or maximum roll to one side.
- ω_{0_r} is the natural frequency in roll.

$$\omega_{0_r} = \sqrt{\frac{k}{I}} = \sqrt{\frac{\overline{GM}_T \cdot g}{r_x^2}} \quad 15$$

- Δ is mass displacement and is given by: $\Delta = m \cdot g$
- D is draught and is given by: $D = \frac{\Delta}{\rho \cdot g \cdot A_w} = \frac{m}{\rho \cdot A_w}$
- ∇ is volume displacement and is given by: $\nabla = A_w \cdot D = \frac{m}{\rho}$
- t is time

The natural period in air for the roll motion, T_{r_air} , will then be

$$T_{r_air} = \frac{2\pi}{\omega_{0_r}} = 2\pi \sqrt{\frac{r_x^2}{\overline{GM}_T \cdot g}} \quad 16$$

The period of roll is independent of φ_r as long as the approximation $\overline{GZ} = \overline{GM}_T \cdot \varphi_r$ applies. Added mass should also be considered in the evaluation of r_x . From the formula it is shown that a large \overline{GM}_T gives a small T_{r_air} . A vessel with a short roll period is said to be stiff and one with longer period is said to be tender. For humans onboard the vessel it is found to be more pleasant with a long period than a short. From this argumentation it is clear that the natural period in roll should be included in the discussion of how large the \overline{GM}_T should be.

4.3.2.1.2. Pitch

The derivation of the period in pitch follows the same derivation as for roll. The difference is the use of longitudinal \overline{GM}_L instead of the transverse. The radius of gyration is also changed and will now be with respect to the y-axis. Then we get the following equation of motion:

$$\ddot{\varphi}_p + \frac{g \cdot \overline{GM}_L}{r_y^2} \varphi_p = 0 \quad 17$$

Where

- Longitudinal metacentric height, $\overline{GM}_L = \overline{KB} + \overline{BM}_L - \overline{KG}$
 - o The metacentre will in this case be positioned higher than the metacentre in the transverse case. Thereby \overline{BM}_L becomes larger which gives a larger \overline{GM}_L .
- Mass radius of gyration, $r_y = \sqrt{\frac{I_y}{m}}$

The natural period in air for the pitch motion is then given by:

$$T_{p_air} = 2\pi \sqrt{\frac{r_y^2}{\overline{GM}_L \cdot g}} \quad 18$$

It is also important to emphasize that equation 18 is only valid for very small angles of pitch.

4.3.2.1.3. Heave

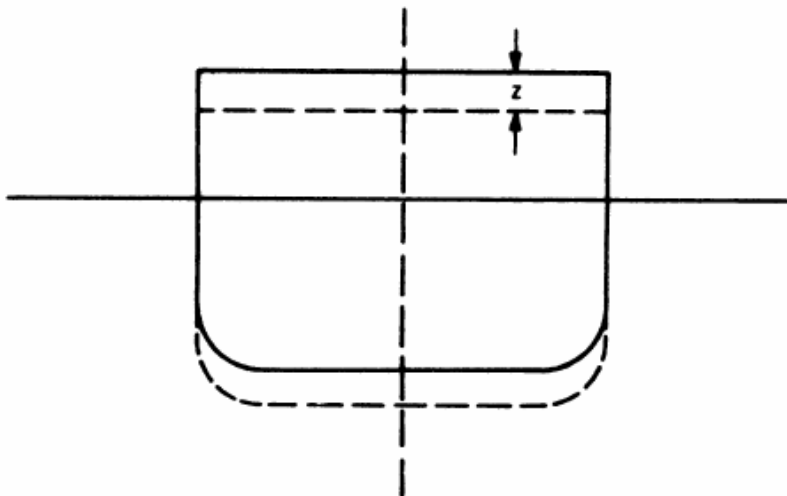

Figure 22: Heaving (Rawson and Tupper, 2001b)

The principle of heave is shown in Figure 22.

If the principle shown in Figure 19 is used to find the equation of motion in air, the following result will appear.

$$m \cdot \ddot{z} + c \cdot \dot{z} + k \cdot z = F(t) \quad 19$$

For an undamped free motion $c = F(t) = 0$ equation 19 becomes:

$$m \cdot \ddot{z} + k \cdot z = 0 \quad 20$$

The solution of the differential equation 20 can be written as:

$$z = z_0 \sin(\omega_{0_h} \cdot t) \quad 21$$

Where

- z_0 is the amplitude in heave
- ω_{0_h} is the natural frequency in heave and is given by:

$$\omega_{0_h} = \sqrt{\frac{k}{m}} \quad 22$$

- t is time

The natural period in air for the heave motion will then be:

$$T_{h_air} = \frac{2\pi}{\omega_{0_h}} = 2\pi \sqrt{\frac{m}{k}} \quad 23$$

k may be written as:

$$k = A_w \cdot \rho \cdot g \quad 24$$

Where A_w is the water line area. Equation 23 will then become:

$$T_{h_air} = 2\pi \sqrt{\frac{m}{A_w \cdot \rho \cdot g}} \quad 25$$

Where the mass, m , is the total mass excluded added mass which is treated in the next chapter.

It can be seen that the displacement and the water line area are the two variables which decides the natural period in air for the heave motion. A large mass will give a large natural

period in heave.

4.3.2.2. Natural periods included added mass

After the natural periods in air for the three motions are determined, the added mass contribution can be found using Figure 23 to Figure 25 given by Brown & Root Vickers (1990). Within these figures the following parameters are defined as:

$$H = \frac{B}{2D}$$

$$\lambda = \frac{g \cdot T^2}{2\pi}$$

Where

- B = barge beam [m]
- D = barge draught [m]
- L = barge length [m]
- T = natural period in air [s]

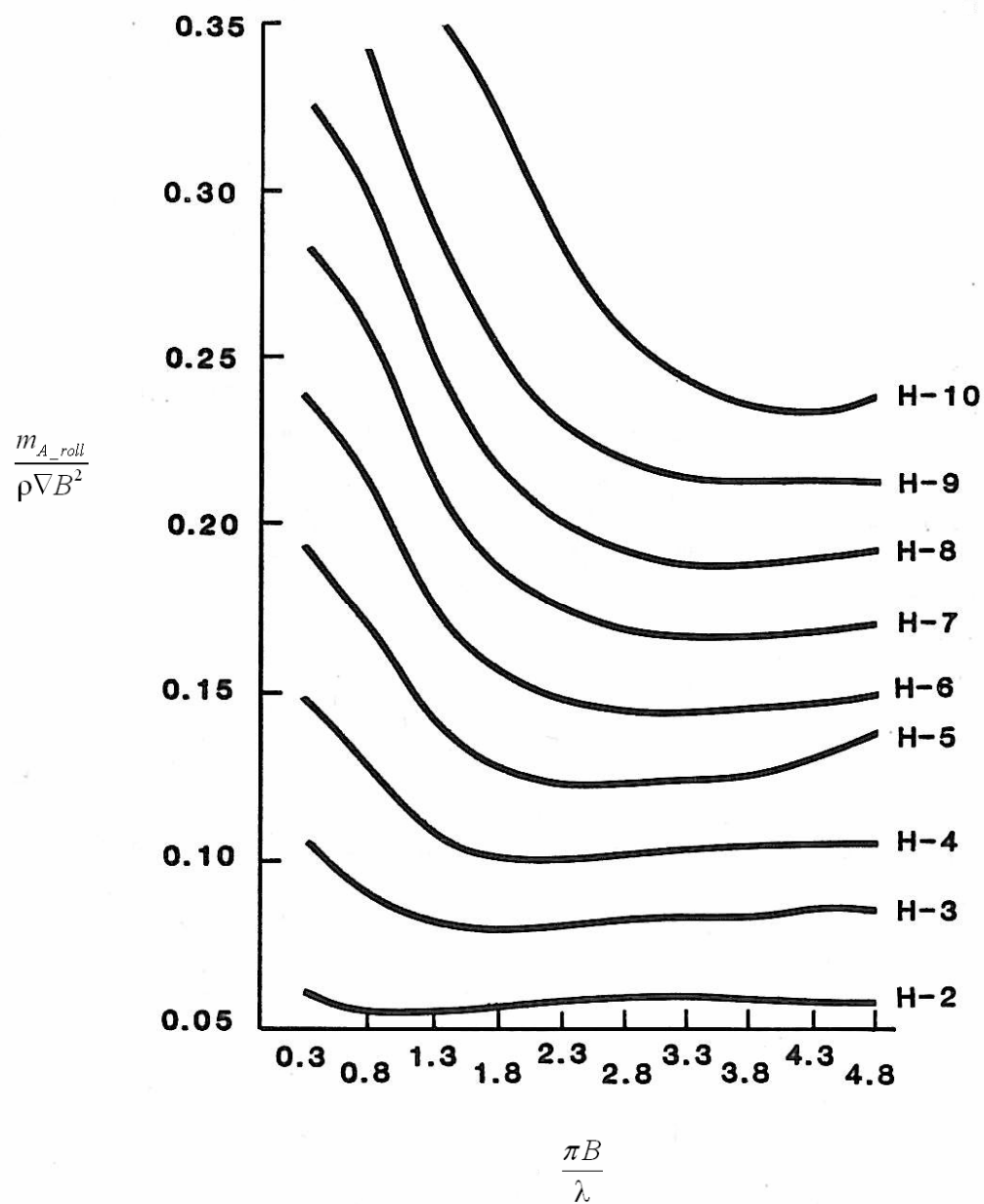

Figure 23: Roll added inertia, m_{A_roll} , for prismatic barge (Brown & Root Vickers, 1990).

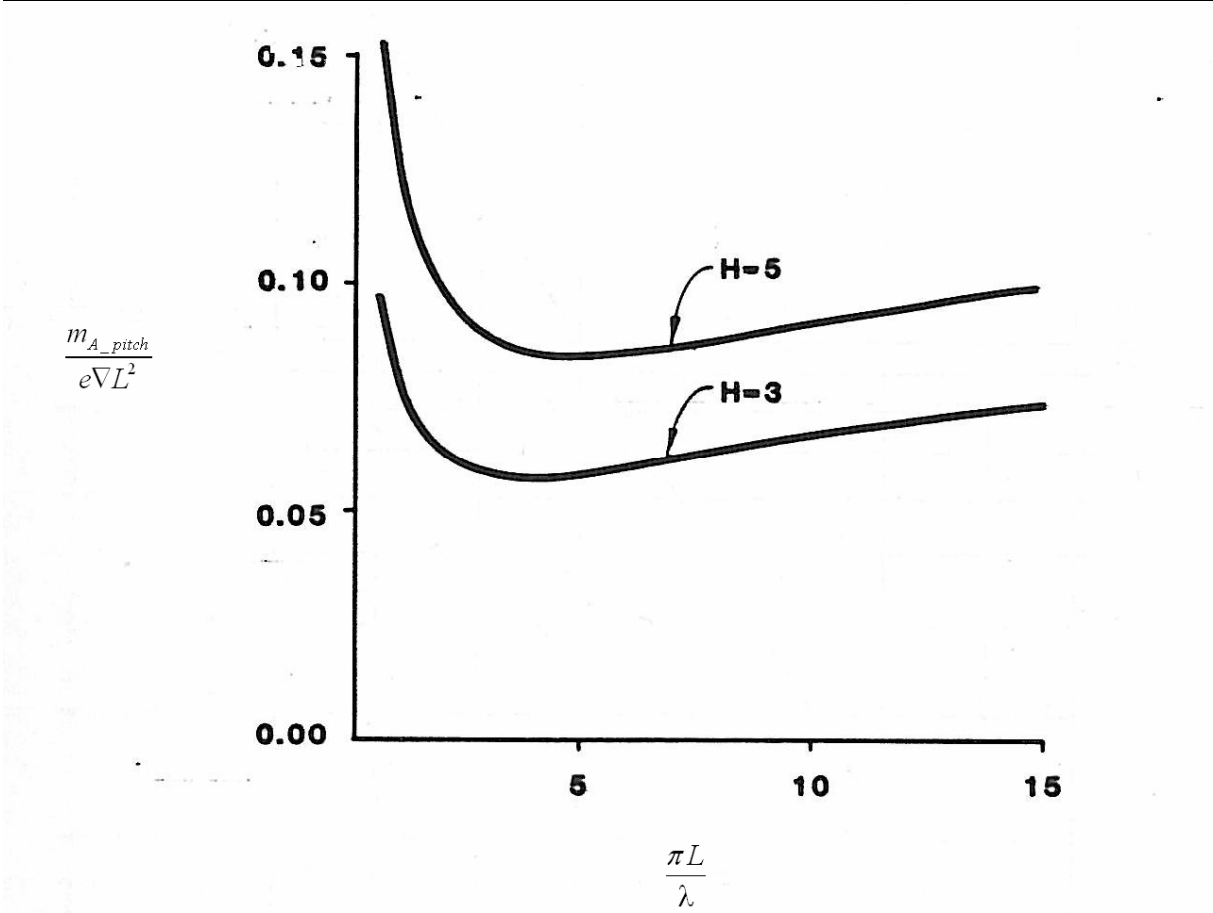

Figure 24: Pitch added inertia, m_{A_pitch} , for prismatic barges (Brown & Root Vickers, 1990)

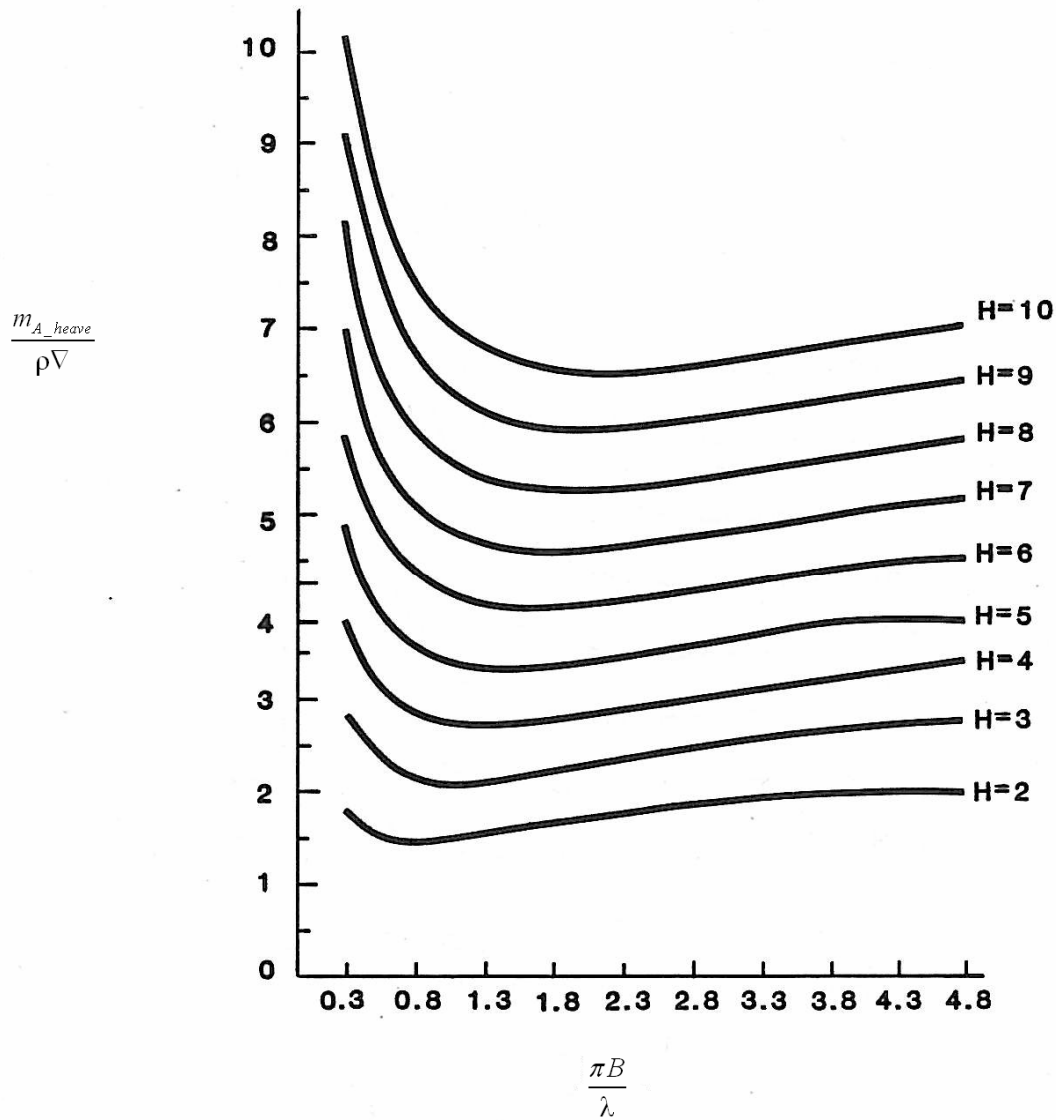

Figure 25: Heave added mass, m_{A_heave} , for prismatic barges (Brown & Root Vickers, 1990)

The natural periods will get a contribution from the added mass and the total values in each degree of freedom are:

$$T_r = 2\pi \sqrt{\frac{r_x^2 + m_{A_roll}}{GM_T \cdot g}} \quad 26$$

$$T_p = 2\pi \sqrt{\frac{r_y^2 + m_{A_pitch}}{GM_L \cdot g}} \quad 27$$

$$T_h = 2\pi \sqrt{\frac{m + m_{A_heave}}{A_w \cdot \rho \cdot g}} \quad 28$$

It can be seen that the added mass phenomenon gives a significantly increase in the natural periods.

4.3.3. Damped motion in still water

It can be seen from Figure 20 that damping may reduce the amplitude significantly, especially in conditions with wave periods around the natural periods of the barge. Rawson and Tupper (2001b) have given an illustration of the effect of damping on the roll motion. They have only considered the simplest case of damping, that in which the damping moment varies linearly with the angular velocity. When this is not the case the differential equation used is no longer capable of giving a solution.

Allowing for entrained water the equation for roll in still water, equation 12 becomes

$$\frac{\Delta}{g} r_x^2 (1 + \sigma_{xx}) \ddot{\phi}_r + B \dot{\phi}_r + \overline{\Delta GM_T} \phi_r = 0 \quad 29$$

Where

- $\frac{\Delta r_x^2}{g} \sigma_{xx}$ is the increase of rolling inertia of ship due to entrained water
- B is the damping constant

From this the standard differential equation appears:

$$\ddot{\phi}_r + 2k\omega \dot{\phi}_r + \omega^2 \phi_r = 0 \quad 30$$

Where

- $\omega^2 = \frac{g \overline{\Delta GM_T}}{r_x^2 (1 + \sigma_{xx})}$

$$- \quad k = \frac{Bg}{2\omega\Delta r_x^2(1 + \sigma_{xx}^2)}$$

This gives the effective period T_{rd} of the motion

$$T_{rd} = \frac{2\pi}{\omega\sqrt{1-k^2}} = 2\pi r_x \sqrt{\frac{1 + \sigma_{xx}}{gGM_T}} \frac{1}{\sqrt{1-k^2}} \quad 31$$

Looking at Figure 20 it can be seen that an undamped situation will give larger amplitudes than a damped situation. So the undamped values of the acceleration and forces will be conservative.

4.3.4. Motion in regular waves

Figure 17 shows that an irregular sea state is a compound of a large number of regular components. The irregular waves give the barge an irregularity in the motions. These motions can be regarded as the summation of the responses to all the individual wave components.

The derivation of the equations of motion in regular waves will not be included in this report. However, the principle is that the equation of motion in still water is modified by introducing a forcing function on the right-hand side of the equation, making it non-homogenous. By this way the motions theoretically exhibit a forced oscillation in addition to the free oscillations mentioned in the still water derivation.

By using the equation of motion for undamped roll in beam seas as an example, the solution of the angular displacement (roll) can be written as (Rawson and Tupper, 2001b)

$$\varphi_r = \varphi_{0_r} \sin(\omega_{0_r}t + \phi) + \frac{\omega_{0_r}^2 \alpha}{\omega_{0_r}^2 - \omega^2} \sin \omega t \quad 32$$

Where

- φ_{0_r} and ω_{0_r} are the amplitude and frequency of unresisted roll in still water.
- α is the maximum slope of the surface wave
- ω is the frequency of the surface wave

-
- ϕ is the phase

Here the first term is the free oscillation in still water and the second is a forced oscillation at the period of the wave train. Angular velocity and acceleration can then be found by differentiating this equation.

4.3.5. Motion in irregular waves

The irregular pattern of a sea state includes a sum of wave heights, lengths, directions and frequencies. In order to analyse wave records and corresponding responses a simplified model is adopted. Typically spectral analysis is used to describe the wave energy as a function of wave frequency. When the wave spectrum is decided it can be used together with the ship response spectrum, this relationship is linear and is expressed in terms of response amplitude operators (RAO).

4.3.5.1. Wave spectra

As mentioned a seaway can be seen as a random process and it is assumed that the irregular sea at a particular point may be described mathematically by the linear superposition of a large number of regular sinusoidal waves of different amplitudes and frequency, that is as Fourier series. This information is typically presented as a wave spectrum which provides the wave energy density as a function of wave frequency. The superposition of regular waves is an assumption that does not exactly describe an irregular wave system; this is especially a problem in higher sea states where non-linear effects such as wave breaking are more pronounced. However, it is relatively simple to apply and, for many applications, quite accurate (Phelps, 1995).

A typical wave spectrum expressed in terms of circular frequency ω (rad/s) is given in Figure 26.

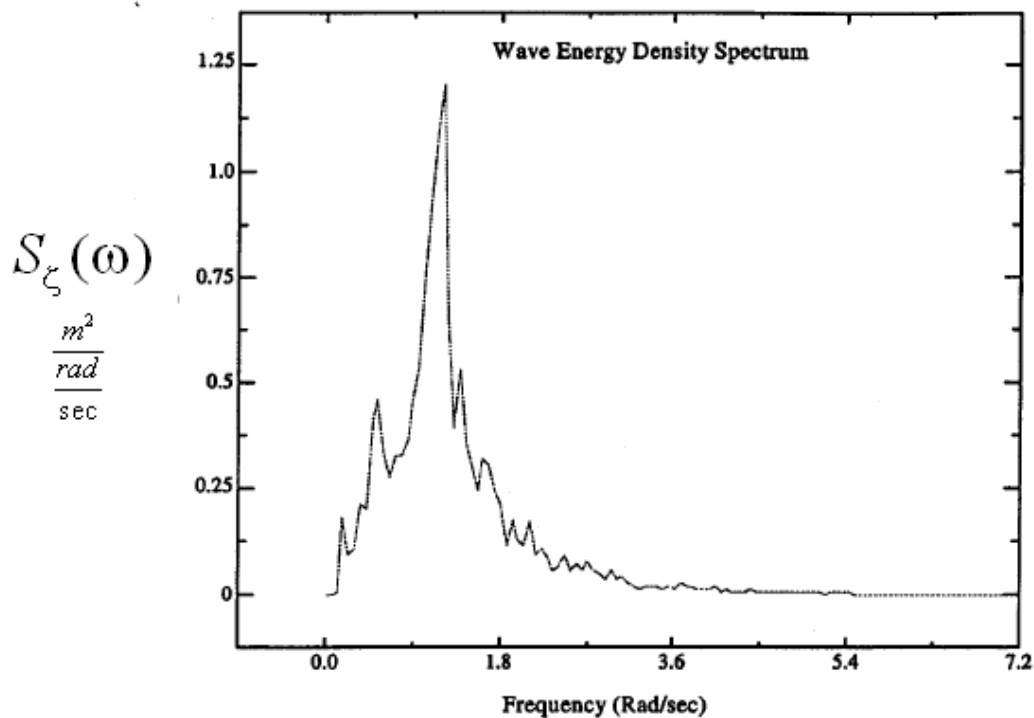

Figure 26: Wave Spectrum (Phelps, 1995)

The derivation of the wave spectra function is given in Phelps (1995). He bases his derivation by using proportionality between an infinitesimal strip of width $\delta\omega$ centred at ω and the energy density of a regular wave frequency, ω . The units of the spectral density ordinates are $\frac{m^2}{rad \cdot sec}$ and since the energy density of a regular wave of frequency ω and amplitude ζ is

$\frac{1}{2}\rho g\zeta^2$, the constant of proportionality must therefore have units of $\rho g \left(\frac{kg}{m^3} \cdot \frac{m}{s^2}\right)$. The area beneath the wave spectrum for the frequency band centred at ω will then be given by⁵:

⁵ Further on Phelps (1995) says that care should be taken when dealing with published wave spectral data as in some cases the constant of proportionality may be taken to be $\frac{1}{2}\rho g$ in which case $S_{2\zeta}(\omega) = 2S_{\zeta}(\omega) = \frac{\zeta^2}{\delta\omega}$.

$$\rho g S_{\zeta}(\omega) \delta \omega = \frac{1}{2} \rho g \zeta^2 \quad 33$$

$S_{\zeta}(\omega)$ is then a function which shows how the energy is distributed in the sea. The function may be written as:

$$S_{\zeta}(\omega) = \frac{1}{2} \frac{\zeta^2}{\delta \omega} \quad 34$$

From equation 34 the variance can be obtained by integration:

$$E(\zeta(t)^2) = m_0 = \int_0^{\infty} S_{\zeta}(\omega) d\omega \quad 35$$

This means that the area beneath the spectrum is equal to the variance of the wave system. The notation m_0 is used to refer to the variance as it is in fact the zeroth moment of the spectral area about the origin. This can be shown by using the equation for the spectrum's moments:

$$m_j = \int_0^{\infty} \omega^j \cdot S_{\zeta}(\omega) \cdot d\omega \quad 36$$

By using the value of the zeroth moment several other values can be defined.

- Significant wave height:

- $H_s = 4\sqrt{m_0}$

- The most probable wave height:

- $H_m = \sqrt{m_0}$

- The average wave amplitude:

- $\bar{\zeta}_0 = 1,25 \cdot \sqrt{m_0}$

By using moments higher than the zeroth these aspects, among others, may be defined:

-
- Average frequency: $\frac{m_1}{m_0}$
 - Characteristic period (of the component wave of average frequency): $2\pi \frac{m_0}{m_1}$
 - Average wave period between crests or troughs: $2\pi \sqrt{\frac{m_2}{m_4}}$

The wave energy spectrum is only defined for a fixed point in space so further processing of it will include a transformation of the spectrum to the frame of reference moving with the ship.

Various attempts have been made to establish idealised wave spectral families which would enable designers and hydrographers to define the wave spectrum through a limited number of parameters (Phelps, 1995). Often the use of these spectra is appropriate only to a particular stage of wave generation.

Most of the spectra have the form:

$$S_{\zeta}(\omega) = \frac{A}{\omega^{\alpha}} \exp\left[\frac{-B}{\omega^{\beta}}\right] \quad 37$$

Where A and B are constants, α and β are empirically derived coefficients and ω is the wave frequency

Phelps (1995) have listed the most common spectra and given a short description of each of them.

- Pierson-Mokowitz Spectrum is an open water spectrum which depends only upon a single parameter, the wind speed. It is intended to describe the point spectrum for fully developed seas and was developed primarily for oceanographic use.
- The Bretschneider spectrum is an open water spectrum and is designed to represent both rising and falling seas as well as fully developed seas.
 - o ISSC adopted the Bretschneider spectrum to be used in conjunction with observed wave height and period.

-
- This spectrum was also recommended by the 15th International Towing Tank Conference (ITTC) for average conditions when the significant wave height is the only information available.
 - The Joint North Sea Wave Project Spectrum (JONSWAP) was set up to study the growth of waves under conditions of limited fetch and under the effects of shoaling water. This spectrum is modified by a frequency dependent peak enhancement factor. The effect of this factor gives a spectrum which is narrower and has higher peaks than the standard Pierson-Mokowitz form. This spectrum is more suitable for storm conditions than fully developed open ocean waves. A more thorough explanation of this spectrum is given in Appendix B3.
 - The Ochi 6-parameter Spectrum is a family of spectrum developed by Ochi and Hubble. This family provides in general a better fit to measured wave spectra than the previously mentioned spectra, particularly in cases where the spectrum is bi-modal (more than one peak).
 - Torsethaugen is a two peak wave spectrum. The model includes locally generated wind sea and swell. Two types of sea states are defined dependent on the location of the spectral peak. Type I is the wind sea where the highest peak is caused by local wind and Type II where the highest peak is caused by swell. Each of the two peaks are modelled by an extended JONSWAP spectrum. The parameters in the model are only dependent on significant wave height and spectral peak period and are divided in site independent and site dependent parameters. This spectrum is commonly used in the North Sea.

4.3.5.2. Response Amplitude Operators (RAO)

When a vessel moves through a seaway, the frequency at which it encounters the waves is different from the actual wave frequency due to a Doppler shift effect. Let ψ be the heading angle between the vessel's direction and the direction of the waves, and V the forward velocity of the vessel. Then the encounter frequency ω_e can be written as (Phelps, 1995)

$$\omega_e = \omega - \frac{\omega^2}{g} \cdot V \cdot \cos(\psi) \quad 38$$

The relationship between the wave spectrum and the ship response spectrum, $S_r(\omega)$, is often assumed to be linear and is expressed in terms of Response Amplitude Operators (RAO) (Phelps, 1995). In some literature the RAO is also called a transfer function.

$$S_r(\omega_e) = |H_{r\zeta}(\omega_e)|^2 \cdot S_\zeta(\omega_e) \quad 39$$

Where

- $S_r(\omega_e)$ is the ship response spectrum
- $|H_{r\zeta}(\omega_e)|$ is the response amplitude operator (RAO)
- $S_\zeta(\omega_e)$ is the wave spectrum

The RAO is a frequency dependent function which provides the ratio of the response spectrum to the input spectrum over the entire frequency range, it can be described mathematically as

$$RAO = |H_{r\zeta}(\omega_e)|^2 = \left[\frac{1}{k \sqrt{(1-\beta^2)^2 + (2\xi\beta)^2}} \right]^2 \quad 40$$

Where

- ω is the wave frequency
- k is the spring constant
- β is the frequency ratio $\frac{\omega}{\omega_{0_i}}$
 - o ω_{0_i} is the natural frequency of the DOF concentrated on. Like mentioned earlier, Chapter 404.3.1, this natural frequency is dependent of added mass which is dependent of wave frequency.

- ξ is the damping ratio

RAOs are often given in curves. Figure 27 gives an example of typical curves for heave, roll and sway.

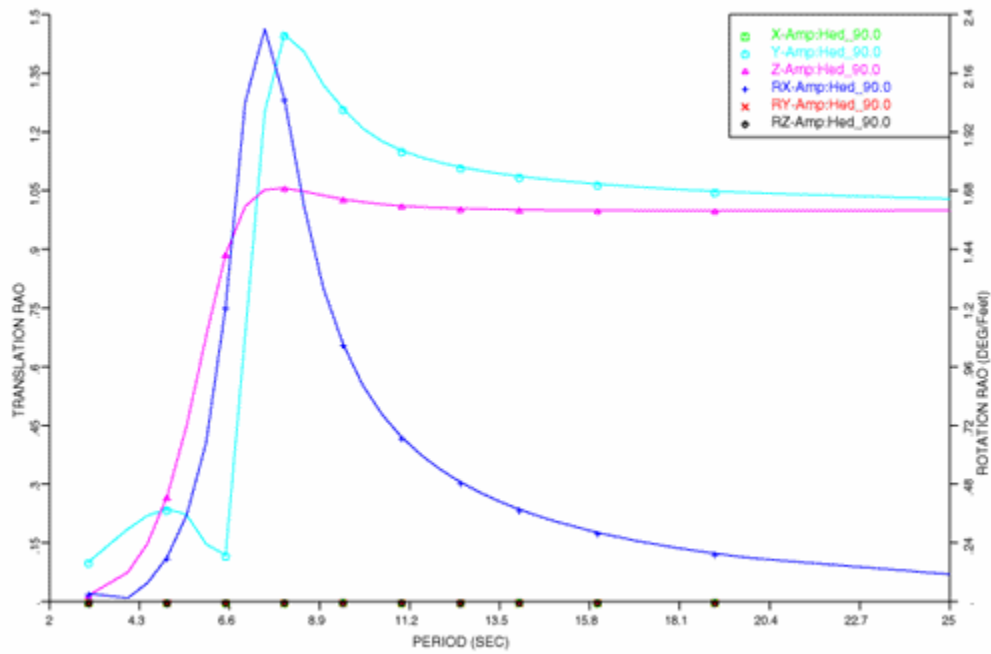

Figure 27: Response amplitude operators in heave, roll and sway for a barge.

It is important to emphasize that the result obtained when RAOs are calculated is not exactly correct due to simplifying approximations and assumptions. The end result is that the calculated response spectrum typically overestimates the response of the vessel for higher wave loadings (Phelps, 1995). One approach to try to improve these predictions is to carry out model or full scale tests, then experimental RAOs can be determined and used instead.

When $S_r(\omega_e)$ has been decided a transformation have to be made. This is done through the following equation:

$$u(t) = \int_{-\infty}^{\infty} S_r(\omega_e) e^{i\omega_e t} d\omega_e \quad 41$$

The motion $u(t)$ can be differentiated to find the velocity, and differentiated once more to find the acceleration.

4.3.6. Surge, sway and yaw

When a barge that moves forward with a constant speed meets waves, there will be a change in the resistance and thereby reduction of the speed. The speed is no longer constant and the term surge is used to define the variation in speed. (Rawson and Tupper, 2001b)

In an irregular sea the height and hence the resistance of successive waves varies, which leads to a more irregular speed variation.

When the wave system is other than immediately ahead or astern of the ship, there will be transverse forces. These forces would, in regular seas, potentially lead to a regular motion in the period of encounter with the waves, but this is not the case. They lead to an irregular transverse motion about a mean sideways drift. This variation about the mean is termed sway. This motion is also influenced by the transverse forces acting on the rudder and hull due to actions to counteract yaw.

The term yaw is used about the variation in the barge's heading about its mean heading. This occurs when the wave system is at an angle to the line of advance of the barge. The transverse forces acting on the barge will introduce moments tending to yaw the vessel. Corrective actions by the rudder introduce additional moments and the resultant moments cause an irregular variation in the ship's heading.

4.4. Motions and forces

When the motions have been decided, they can be used to find the forces to use when seafastening for the cargo is to be designed. There is one assumption to be made when the motion results are converted into loading cases for the cargo. It is assumed that all maximum responses for a given sea direction are acting simultaneously, for example maximum linear accelerations occur simultaneously with maximum angular displacement (Brown & Root Vickers, 1990). This assumption is conservative in that the phase relationships between the motion components are ignored.

4.4.1. Roll

After the natural periods are decided it is important to analyze the angular displacement, the

angular velocity and the angular acceleration.

When the barge floats horizontally in the water there will be no horizontal force on the seafastening. However, when the barge starts to roll, a sideways force will increase as the angular displacement increases. The maximum and dimensioning *angular displacement* is decided by the amplitude, φ_0 , given in equation 14.

The gravity force given by the angular displacement is then described by:

$$F_{\varphi_{0_r}} = m \cdot g \cdot \sin(\varphi_{0_r}) \quad 42$$

The description of the *angular velocity* is found by differentiating equation 14.

$$\dot{\varphi}_r = \omega_{0_r} \varphi_{0_r} \cos(\omega_{0_r} \cdot t) \quad 43$$

If equation 43 gets differentiated once more the description of the *angular acceleration* appears.

$$\ddot{\varphi}_r = -\omega_{0_r}^2 \varphi_{0_r} \sin(\omega_{0_r} \cdot t) \quad 44$$

Acceleration together with mass gives a force which the seafastening has to cope with. Acceleration is also a factor in the comfort aspect. The maximum acceleration is given when $\sin(\omega_{0_r} t) = 1$.

$$\ddot{\varphi}_{r_max} = \omega_{0_r}^2 \varphi_{0_r} \quad 45$$

The transverse force acting along the deck surface is thereby given by the sum of the force from the gravity and the force from the acceleration of the roll motion.

$$F_r = F_{\varphi_{0_r}} + m_{cargo} \cdot \ddot{\varphi}_{r_max} \cdot l_r \quad 46$$

Where l is the distance from the centre of roll to the point of interest.

4.4.2. Pitch

As for the derivation of the natural period, pitch and roll are quite similar. Here we have the

following equations for the angular displacement, angular velocity and angular acceleration:

Angle:

$$\varphi_p = \varphi_{0_p} \sin(\omega_{0_p} \cdot t) \quad 47$$

Angular velocity:

$$\dot{\varphi}_p = \omega_{0_p} \varphi_{0_p} \cos(\omega_{0_p} \cdot t) \quad 48$$

Angular acceleration:

$$\ddot{\varphi}_p = -\omega_{0_p}^2 \varphi_{0_p} \sin(\omega_{0_p} \cdot t) \quad 49$$

The total longitudinal force acting on the seafastening will then be:

$$F_p = F_{\varphi_{0_p}} + m \cdot \ddot{\varphi}_{p_max} \cdot l_p \quad 50$$

Where

- $F_{\varphi_{0_p}} = m \cdot g \cdot \sin(\varphi_{0_p})$
- $\ddot{\varphi}_{p_max} = \omega_{0_p}^2 \varphi_{0_p}$
- l_p is the distance from the centre of the pitch to the point of interest.

4.4.3. Heave

There are several areas of consideration when looking at the translation in the vertical axis. The motion given by equation 21, where z_0 is the amplitude, is important in vertical operations. The maximum value of the motion is simply z_0 . It is assumed that the barge follows the wave motion.

$$z_0 = \frac{H}{2} \quad 51$$

The velocity is given by differentiating equation 21. Then the following description of the

velocity is given:

$$\dot{z} = \omega_{0_h} \cdot z_0 \cdot \cos(\omega_{0_h} \cdot t) \quad 52$$

And the maximum velocity:

$$\dot{z}_{\max} = \omega_{0_h} \frac{H}{2} \quad 53$$

At last the acceleration of the vessel. This factor makes a force which the seafastening needs to transmit to the cargo. Its description is given by differentiate equation 52.

$$\ddot{z} = -\omega_{0_h}^2 \cdot z_0 \cdot \sin(\omega_{0_h} \cdot t) \quad 54$$

And the maximum value of the acceleration:

$$\ddot{z}_{\max} = \omega_{0_h}^2 \frac{H}{2} \quad 55$$

The vertical force from the acceleration will then be given by:

$$F_p = m_{\text{cargo}} \cdot \ddot{z}_{\max} \quad 56$$

5. Design Criteria

The guidelines for the operation are given by Noble Denton (2005) and DNV (1996). The report will list the criteria from both guidelines and discuss each of them. The criteria looked at are limited to those relevant for stability and motion response.

5.1. Physical environmental conditions

DNV (1996) have explained the physical environmental conditions as the natural phenomena which contribute to structural stress and strain, impose operational limitations/restrictions or navigational considerations. Phenomena of general importance are;

- wind
- waves

Surface currents may also be important for transport on barges. Noble Denton (2005) states that each transport shall be designed to withstand the loads caused by the most adverse environmental conditions expected for the area and season through which it will pass. Further on, the guidelines (Noble Denton, 2005) define weather restricted operations and unrestricted operations. The main difference is that a restricted operation may have an operational reference period, which includes the planned duration of the operation plus a contingency period, less than 72 hours. An operation with a reference period greater than 72 hours may also be classed as a restricted operation provided that some demands are fulfilled. Unless these demands are fulfilled the operation is classed as an unrestricted operation.

The design environmental conditions may be set independent of extreme statistical data if it is a restricted operation and if some demands are fulfilled. One of the demands is that an acceptable weather forecast is available. The uncertainties in weather forecasts should be included by applying operation criteria less than the design criteria. The operation criteria should be taken as;

$$C_o \leq \alpha \cdot C_D$$

Where

- C_D is the design criteria
- C_O is the operation criteria
- α is the ratio between the two criterias
 - o for significant waves, α should be taken from Table 1.
 - o for wind (10 minutes mean), α should be taken as 0,80.

Table 1: α -values for significant wave heights (DNV, 1996 Table 3.1)

Operational Period [hours]	Design Wave Height [m]		
	$1 < H_s \leq 2$	$2 < H_s \leq 4$	$H_s > 4$
$T_R < 12$	0.68	0.76	0.80
$T_R < 24$	0.63	0.71	0.75
$T_R < 48$	0.56	0.64	0.67
$T_R < 72$	0.51	0.59	0.63

Note: Table 3.1 is based on DNMI report DSO265/LUND-95/15325, dated 95-05-04 verifying forecasted wave heights at Ekofisk and Statfjord.

The unrestricted operations should be based on extreme value statistics. The operational criteria for these operations may be taken equal to the characteristic environmental conditions (DNV, 1996). This report is based on an unrestricted operation.

Noble Denton (2005) states that the transportation should generally be designed for the 10-year monthly extremes for the area and season. The intact stability overturning moment should be calculated using the design wind speed which should be the 1 minute mean velocity at a reference height of 10 m above sea level. When looking at the damaged condition the wind velocity should be set to 25.7 m/s, or the velocity used in the intact stability calculations if this is lower. In this report we study in the case transport to a southern North Sea field during mid summer. A conservative wind speed of 51,4 m/s is used for the intact stability, and thereby 25,7 m/s for the damaged condition.

The wave height for design shall according to Noble Denton (2005) be the significant wave height. The significant wave height, H_s , is approximately the mean height of the largest third of the zero up-crossing waves. H_s should be 6,7 m and the zero upcrossing wave period, T_z ,

is 8,9 seconds. These values are given by the oceanographic and meteorological design data for the Valhall field published by Grant (2005) for BP. The report uses a JONSWAP wave spectrum. Special information about this can be found in Appendix B3.

5.2. Stability

The stability criteria for the initial and damaged stability are taken from Noble Denton (2005) and DNV (1996). The criteria are presented here and summarized at the end.

5.2.1. Intact stability

Noble Denton (2005) has defined the intact range of stability as the range between 0 degrees heel or trim and the angle at which the righting arm (GZ) becomes negative. The guideline (Noble Denton, 2005) states that cargo barges longer than 76 m and wider than 23 m, should have an intact stability range of 36 degrees. However, if the maximum amplitudes of motion for a specific towage can be derived from model tests or motion response calculations, the stability should be positive to a heel angle beyond equilibrium as given below

$$\phi \geq (20 + 0.8 \cdot \phi_{\max}), \text{ max } 36 \text{ degrees}$$

Where ϕ_{\max} is the maximum amplitude of motion in degrees about the axis concerned, caused by the design seastate plus the static angle of inclination from the design wind. It is also required from Noble Denton (2005) that the metacentric height (\overline{GM}) should be positive throughout the intact range. The initial metacentric height is normally required to be at least around 1m, but it should never be less than 0,15 m. A standard North Sea cargo barge has normally an initial metacentric height of more than 10 m, depending on the mass and the centre of gravity of the cargo. So this is normally not a problem.

In DNV (1996) there are two main criteria regarding initial stability which should be met during all stages of sea transportation operations. The first criterium is in principle the same as the intact range of stability criterium given by Noble Denton (2005), but it is a bit different. The stability should be positive to a heel angle beyond equilibrium as given below:

$$\phi \geq (\phi_{\max} + 15 + \frac{15}{\overline{GM}}), \text{ max } 40 \text{ degrees}$$

ϕ_{\max} should then be smaller or equal to the heel angle where the maximum transverse righting moment occurs, if this is not the case then

$$\phi \geq 40 \text{ deg}$$

Further on, DNV (1996) requires that the areas under the righting moment curve and the wind heeling moment curve should be calculated up to an angle of heel which is the least of;

- the angle corresponding to the second intercept of the two curves,
- the angle of progressive flooding, or
- the angle at which overloading of a structural member occurs.

The area under the righting moment curve should not be less than 1.4 times the area under the wind heeling moment curve.

This can be illustrated by Figure 28. This criterium is also given by Noble Denton (2005), but it is written and thereby potentially easier to misinterpret.

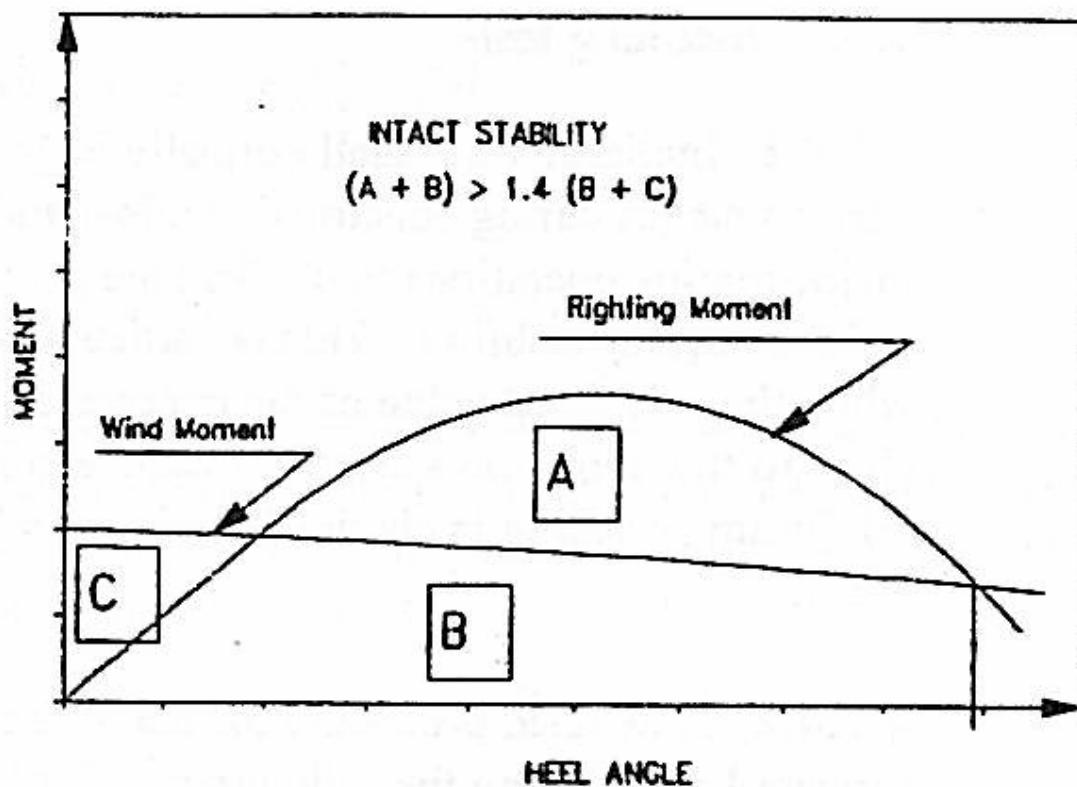

Figure 28: Intact stability requirement (DNV pt 1 ch. 2, 1996)

A requirement to the metacentric height is also given by DNV (1996). They demand that \overline{GM} should be at least 1.0m.

5.2.2. Damaged stability

It is required from both Noble Denton (2005) and DNV (1996) that cargo barges, which are towed on their own buoyancy, should have a positive stability and float in an acceptable manner with any one submerged, or partly submerged, compartment flooded. Two adjacent compartments on the periphery of the unit shall be considered as one compartment if separated by a horizontal watertight flat within 5 m of the towage waterline. This is the case for a flat cargo barge, thereby it is necessary to find the two adjacent compartments which give the worst stability and make sure the stability is good enough if they should get flooded.

The acceptable floating condition is determined by the following:

- The design resistance of any part of the barge, cargo seafastening or grillage should not be exceeded.
- The barge should have sufficient freeboard considering environmental effects to any open compartment, where flooding may occur.
- The area under the righting moment curve should be greater than the minimum under the wind heeling moment curve up to:
 - o The second intercept, or
 - o The down flooding angle, whichever is less.

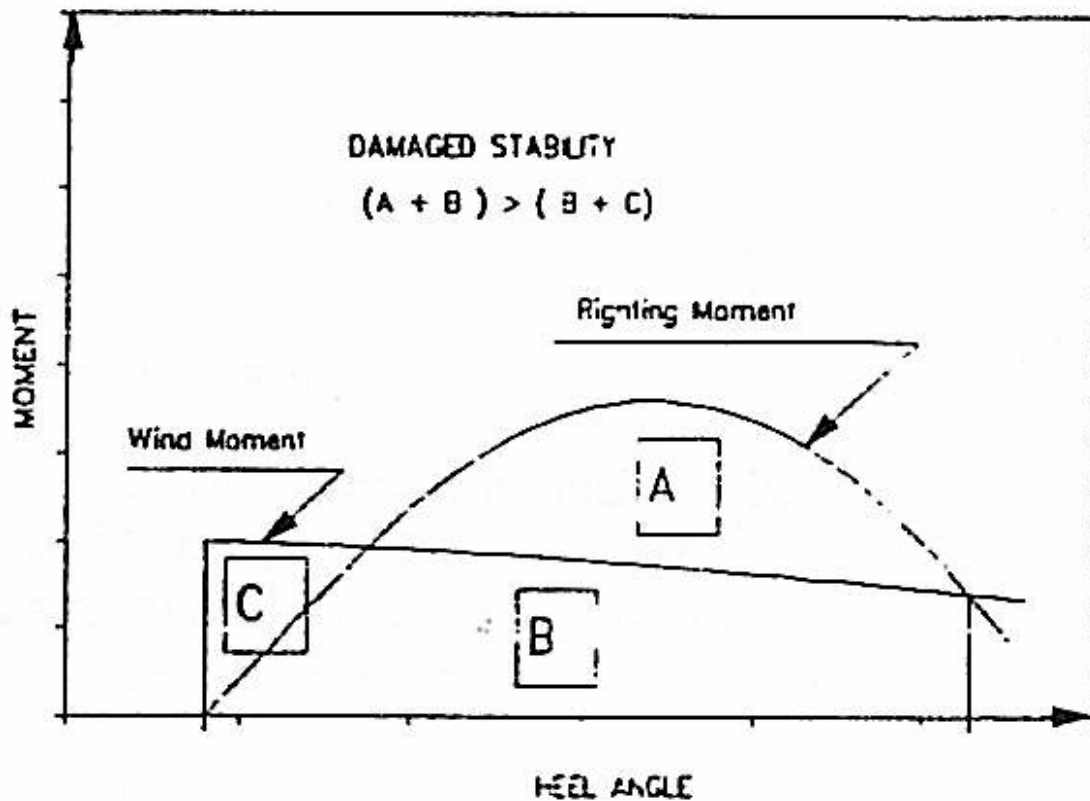

Figure 29: Damage stability requirement (DNV pt. 1 ch. 2, 1996)

Figure 29 is also a requirement in a damaged condition. The related damage criteria in Noble Denton (2005) is more like the requirements of intact stability, thereby Figure 28 can be used according to Noble Denton (2005)

5.2.3. Draft and trim

The draft should, according to Noble Denton (2005), be small enough to give adequate freeboard and stability, and large enough to reduce motions and slamming. Typically, for barge towages, it will be between 45% and 60% of hull depth.

It is useful to have a small trim when towing a barge. Noble Denton (2005) states that a trim around 0,8 m should be a minimum trim by the stern.

5.3. Motion Response

It is stated in the requirements that the dynamic forces acting on the barge, cargo and related seafastenings shall be defined either by model testing, computer aided motion response

analyses or by using default motion values given in the requirements.

For the motion response analyses Noble Denton (2005) states that seastates shall include all relevant spectra up to and including the design wave height for the most severe areas of the proposed voyage route.

For all the seastates considered the peak period (T_p) should be varied as follows (Noble Denton, 2005):

$$\sqrt{13 \cdot H_s} < T_p < \sqrt{30 \cdot H_s}$$

The relationship between the peak period, T_p , and the zero-up crossing period, T_z , is dependent on the spectrum. For a mean JONSWAP spectrum ($\gamma=3,3$) $\frac{T_p}{T_z} = 1,286$. As mentioned earlier $T_z = 8,9m$, then $T_p = T_z \cdot 1,286 = 11,45 \text{ sec}$.

Noble Denton (2005) also requires that the analyses should be carried out with zero vessel speed in addition to an appropriate forward speed. The wave headings should include head, bow quartering, beam, stern quartering and stern seas.

DNV (1996) have also given some guidelines regarding analyses of the barge motions. First of all they agree with Noble Denton (2005) and say that the spacing between the wave headings should not exceed 45 degrees.

From both Noble Denton (2005) and DNV (1996) it is obvious that the natural periods of the barge with cargo should not be in the same area as the wave period. As mentioned earlier this will lead to resonance and thereby large oscillations and accelerations.

Simplified motion criteria

Criteria regarding the accelerations given by Noble Denton (2005) are called default motion criteria. These criteria includes a maximum roll angle of 20 degrees and a maximum pitch angle of 12,5 degrees when the full cycle period is 10 seconds. The criterion for heave is 0,2 g. Further on the guidelines states that roll and heave should be combined, and that pitch and heave should be combined in the same way.

Simplified criteria regarding the accelerations are also given by DNV (1996). The simplified motion criteria may be used for preliminary design evaluations of objects, seafastening and grillage. There are some conditions to be met before these simplified criteria can be used:

- towing in open sea on a flat top barge with length greater than 80m,
- the barge natural period in roll is equal to or less than 7 seconds,
- the object is positioned close to midship and with no part overhanging the barge sides, and
- the object weight is less than 500 tonnes.

The simplified criteria may then be taken as

- a_y (transverse acceleration due to roll and sway): 0,65 g at waterline, increasing 0,015 g each meter above the bottom of the object.
- a_x (longitudinal acceleration due to pitch and surge): 0,45 g at waterline, increasing 0,01 g each meter above the bottom of the object.
- a_z (vertical acceleration due to gravity and heave), maximum 1.35 g, minimum 0.55 g.
- Wind pressure: 1000 N/m²

Both the criteria from Noble Denton (2005) and DNV (1996) are simplified criteria which can be used if neither a motions study nor model tests are performed. This report uses a motions study which is restricted by the criteria through the physical environmental conditions given in Chapter 5.1.

5.4. Summary

The criteria for the stability are summarized in Table 2.

Table 2: Summary of criteria for the stability of the barge

	Noble Denton (2005)	DNV (1996)
Initial stability	$\phi \geq (0,8 \cdot \phi_{\max} + 20)$, max 36 degrees	$\phi \geq (\phi_{\max} + 15 + \frac{15}{GM})$, max 40 degrees
	Area under the righting moment curve, shall not be less than 40% in excess of the area under the wind overturning arm curve, see Figure 28.	Figure 28
Metacentric height (\overline{GM})	>1 m	>1 m
Damaged stability	The barge is required to have positive stability with any one compartment flooded or penetrated. See requirements for initial stability.	The barge is required to have positive stability with any one compartment flooded or penetrated. See requirements for initial stability.
	Area under the righting moment curve, shall not be less than 40% in excess of the area under the wind overturning arm curve, see Figure 28.	The area under the righting moment curve should not be less than the area under the wind moment curve, see Figure 29.

The criteria regarding the accelerations are designed according to the Noble Denton (2005) requirement stating that a transport should use design values for 10-year monthly extremes for the area and season.

6. Case Study

The case study carried out in this report is the transportation of 4 bridges and 2 towers over the North Sea. The analyses which are going to be carried out are stability and motion response analyses.

6.1. Analysis data

Here the different data for the barge and its cargo are presented. Dimensions, mass and centre of gravity are given. The centre of gravity is given with reference to a coordinate system with the origin in the middle of the barge and with the vertical distance starting at the keel.

6.1.1. Barge data

The barge data are shown in Table 3.

Table 3: Barge data

Length	91,44 metres
Breadth	27,432 metres
Depth	6,1 metres
Lightship mass	2409 tonnes
LCG ⁶ (Longitudinal centre of gravity)	0,52 metres
TCG (Transverse centre of gravity)	0 metres
VCG ⁶ (Vertical centre of gravity)	3,56 metres

6.1.2. Cargo data

The cargo weights and centres of gravity have been taken from approved measurement. The cargo data is given in Table 4.

⁶ COG reference point is at the middle of the barge at the keel.

Table 4: Cargo data

Item	Mass (tonnes)	LCG (m)	TCG (m)	VCG (m)	Length (m)	Width (m)	Height (m)
Bridge 6	253,9	28,92	-8,85	12,65	30,0	5,0	7,5
Bridge 7	219,5	-17,05	-10,28	11,35	52,0	4,2	4,5
Bridge 8	206,6	-20,62	-0,30	11,35	45,0	5,0	4,5
Bridge 9	225,4	-15,84	10,28	11,35	53,0	4,2	4,5
WP Tower North	58,1	8,96	3,00	20,85	6,4	4,3	16,5
WP Tower South	54,5	19,42	3,00	21,05	6,7	6,4	16,5
Seafastenings	193,0	-0,72	0,00	9,10			

**Figure 30: Location of modules on barge**

Figure 30 shows the location of each module on the barge. It can be seen that one corner have no cargo, this is because the barge is originally designed with 4 flotation tanks in each corner. Three of these tanks can be removed, but the fourth is fixed and is placed in this corner. Figure 30 can be misunderstood by thinking that the modules is located directly at the top deck, this is not the case. Seafastening, grillage etc are placed underneath each object and thereby the modules are lifted up above the deck.

6.2. Analysis method

The model is built up by using the GeniE program and the analyses are performed by

HydroD. The analyses is split into two, first the stability analysis and then the motion response analysis. A further explanation of the programs is given in Appendix B.

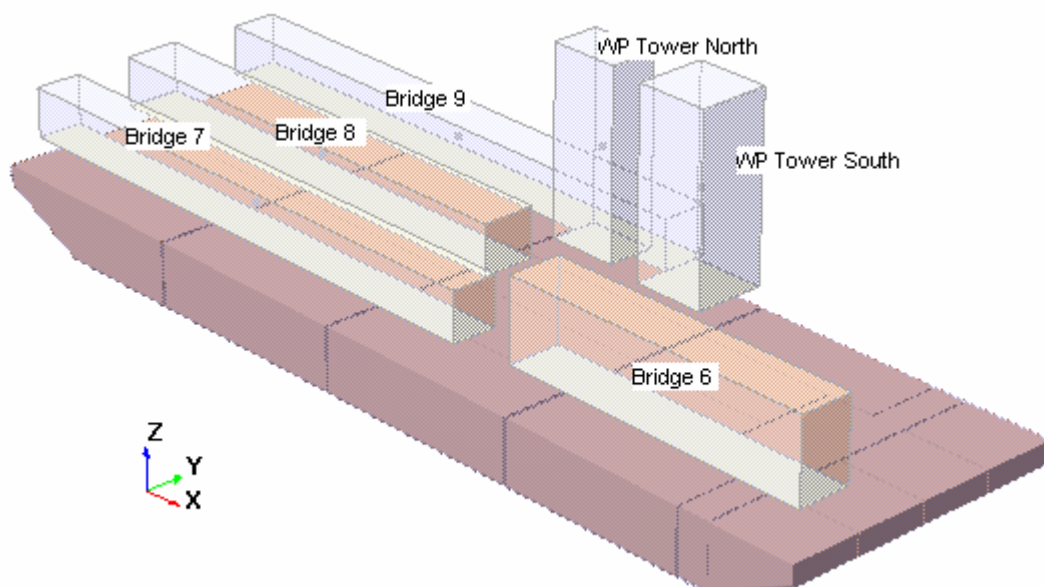
6.2.1. The modelling process

The model is built by using guiding planes and guiding lines. The guiding geometry is the starting point of the model. Figure 31 shows the model with the green guiding planes, the blue guiding lines and the red bottom of the barge.

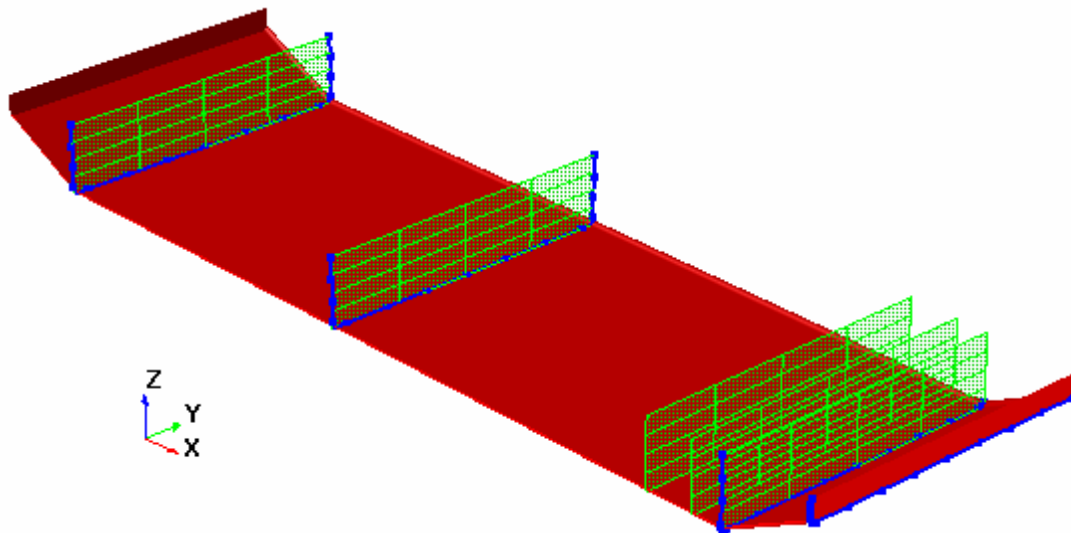

Figure 31: Model of the barge with guiding geometry

After the guiding geometry is decided it is possible to make the panel model. The barge is then modelled by the outside panels and also the inside plates which divide the barge into several ballast compartments. The plates are given as follows:

- Bottom plate, $t_{bottom} = 13,5mm$
- Longitudinal bulkheads, $t_{lbh} = 10,5mm$
- Transverse bulkheads, $t_{tbh} = 10mm$
- Side plates, $t_{side} = 12,5mm$
- Top plate, $t_{top} = 19mm$

The model will then look like Figure 32 . Here one half of the top plate is removed to show the compartments below.

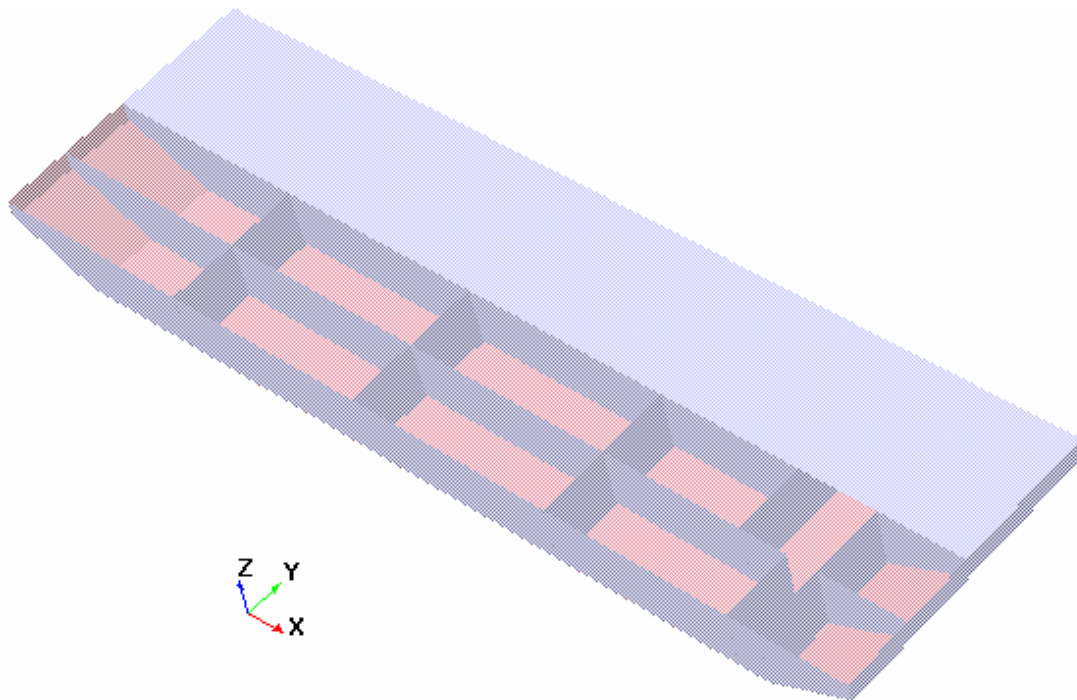

Figure 32: The barge with compartments

After the modelling phase is done it is necessary to make the model ready to be used in HydroD for analyses. First of all the compartment manager in GeniE is used to let the program know that each compartment, limited by the bulkheads, should be regarded as ballast tanks.

Then the load cases for the barge should be set. One load case is set for the wet surface, which is the outer surface subjected to an external hydro pressure, and one load case for each of the compartments. The first load case which corresponds to the wet surface should be a so-called “Dummy hydro pressure”. Here the wet surface also includes the top panel due to the possibility that one corner of the barge gets submerged in case of damaged compartments or other accidents. Load case 1 will then look like Figure 33 inside GeniE.

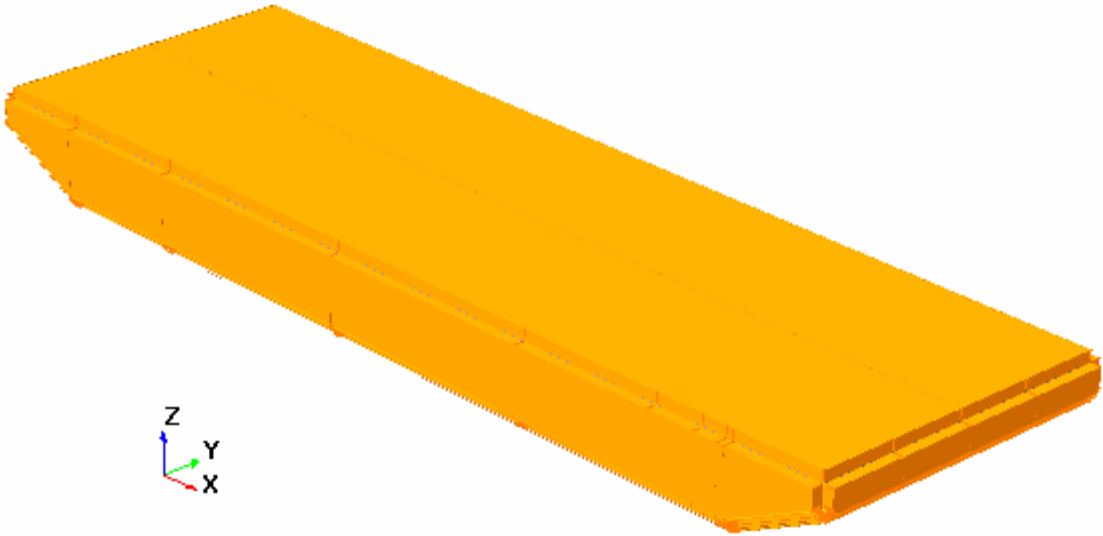

Figure 33: Load case 1, wet surface

Figure 34 shows load case 6 as viewed in GeniE.

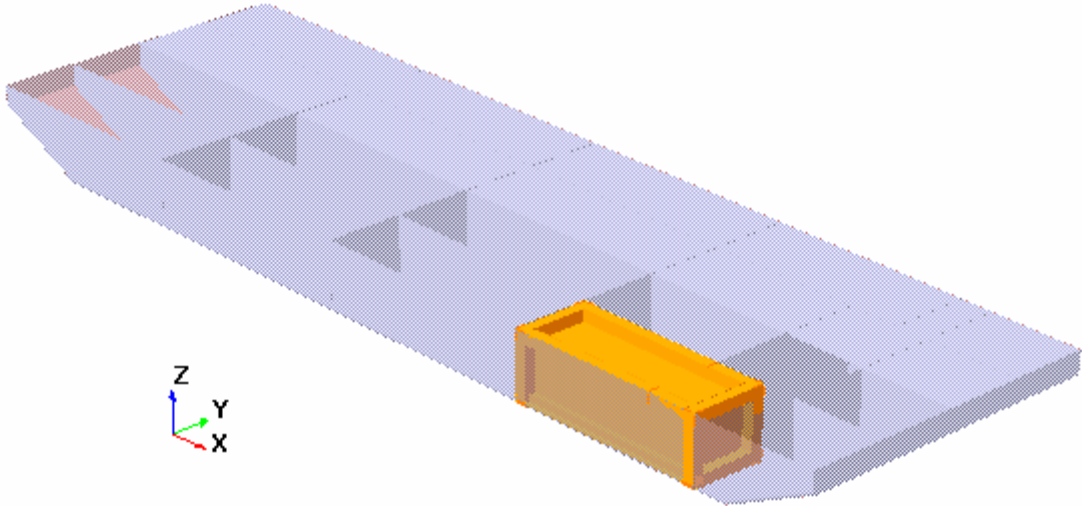

Figure 34: Load case 6, one of the compartments

The filling fraction of each compartment will be defined in HydroD.

When it is ensured that the load cases act as intended a mesh of the barge is made. Figure 35 shows the element model of the barge with an element length of 2,5m.

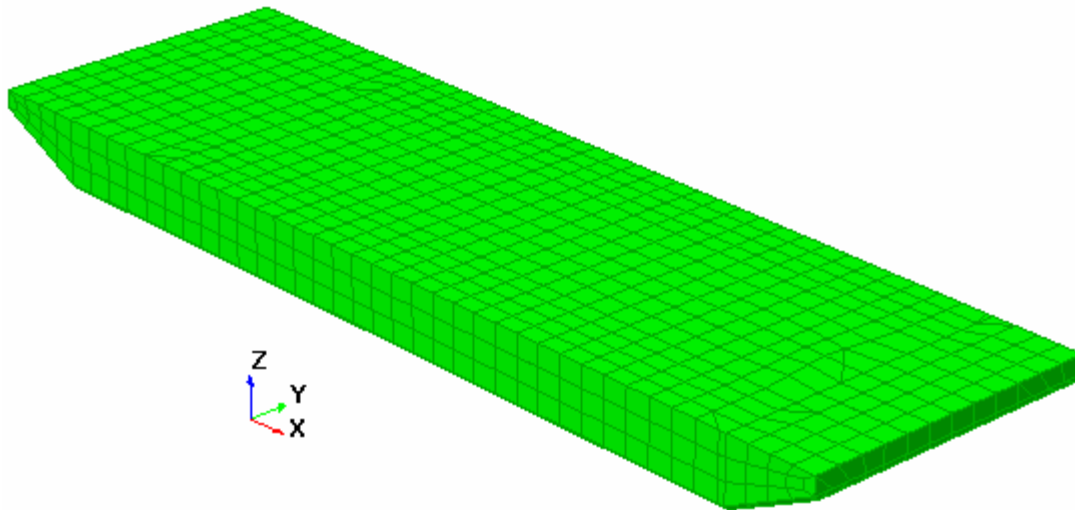

Figure 35: The barge model with mesh

Now the model of the barge is finished. It is then necessary to model the modules which are going to be transported. There are several methods to do this, for example could the equipment option in GeniE be used, but some testing showed that it was better to make a frame of tubular sections and add a point mass on the top of this frame. The masses should then correspond to each end of the bridges transported, while the frames will make sure that the masses have a correct centre of gravity. The sections will not have any mass. Figure 36 shows the model with the frames and the point masses.

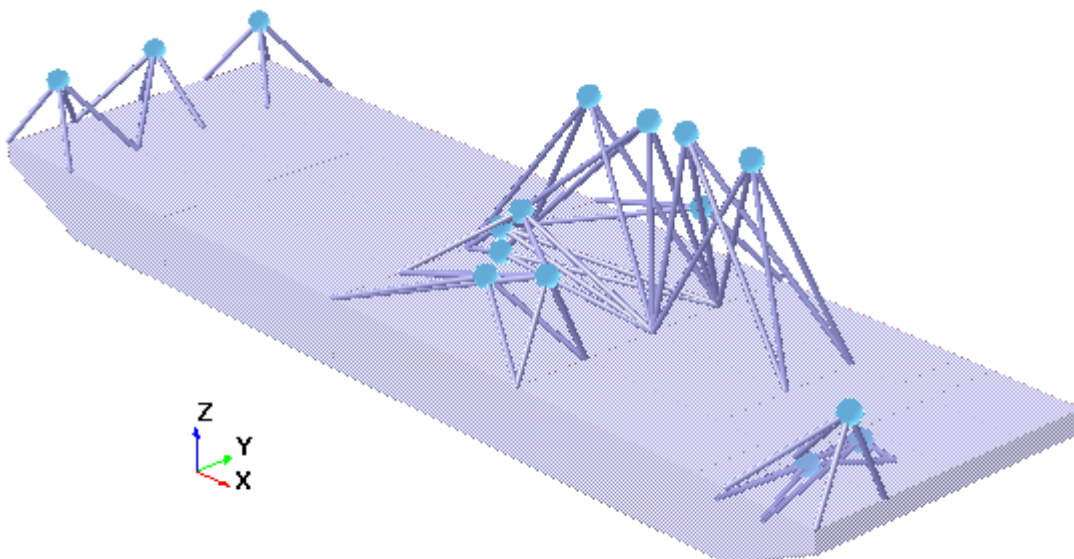

Figure 36: Model barge with cargo

6.2.2. Stability analysis

Barge draft, trim, ballast, and its intact and damaged stability calculations are based on its exterior hull shape and internal compartmentation model, this model is as mentioned earlier imported from GeniE.

It can be seen that the earlier mentioned fixed flotation tank in one of the corners is not included in the model. This is done due to uncertainties regarding the center of gravity of this tank. The mass of it is approximately 60 tonnes and thereby it makes a difference in the lightship centre of gravity.

The ballast configuration used is not optimal as some of the tanks are not full. This will give a free surface effect which is a negative effect for the stability. This ballast configuration was chosen due to a requirement of having a heel angle of 0 degrees and a trim angle close to 0 degrees.

6.2.3. Motion response analysis

When starting the motion response analysis a direction set and relevant wave periods for the incident waves have to be defined. Here the heading angles are defined in 45 degrees spacing between -90 and 90 degrees, where 0 degrees is head seas.

The wave periods are defined to be between 3 and 20 seconds with an interval of 1 second. The area between 6 and 10 seconds are likely to include the barge's natural period, thereby an interval of 0,5 seconds is applied here.

See Appendix B for theory behind the analysis.

After the analysis is performed, the program POSTRESP is used to postprocess the results.

6.2.4. POSTRESP

POSTRESP is used to view the results obtained from WADAM graphically. The transfer functions, $|H(\omega, \beta)|$, from WADAM are called response variables in POSTRESP. In most literature they are named Response Amplitude Operators (RAO).

A short term response spectrum is generated by multiplying the square of the transfer function

with a given wave spectrum for a set of zero up-crossing periods, T_z .

Figure 37 shows a series of wave spectra with a significant wave height of 6,7 metres and where the zero up-crossing period, T_z , is changing for each spectrum.

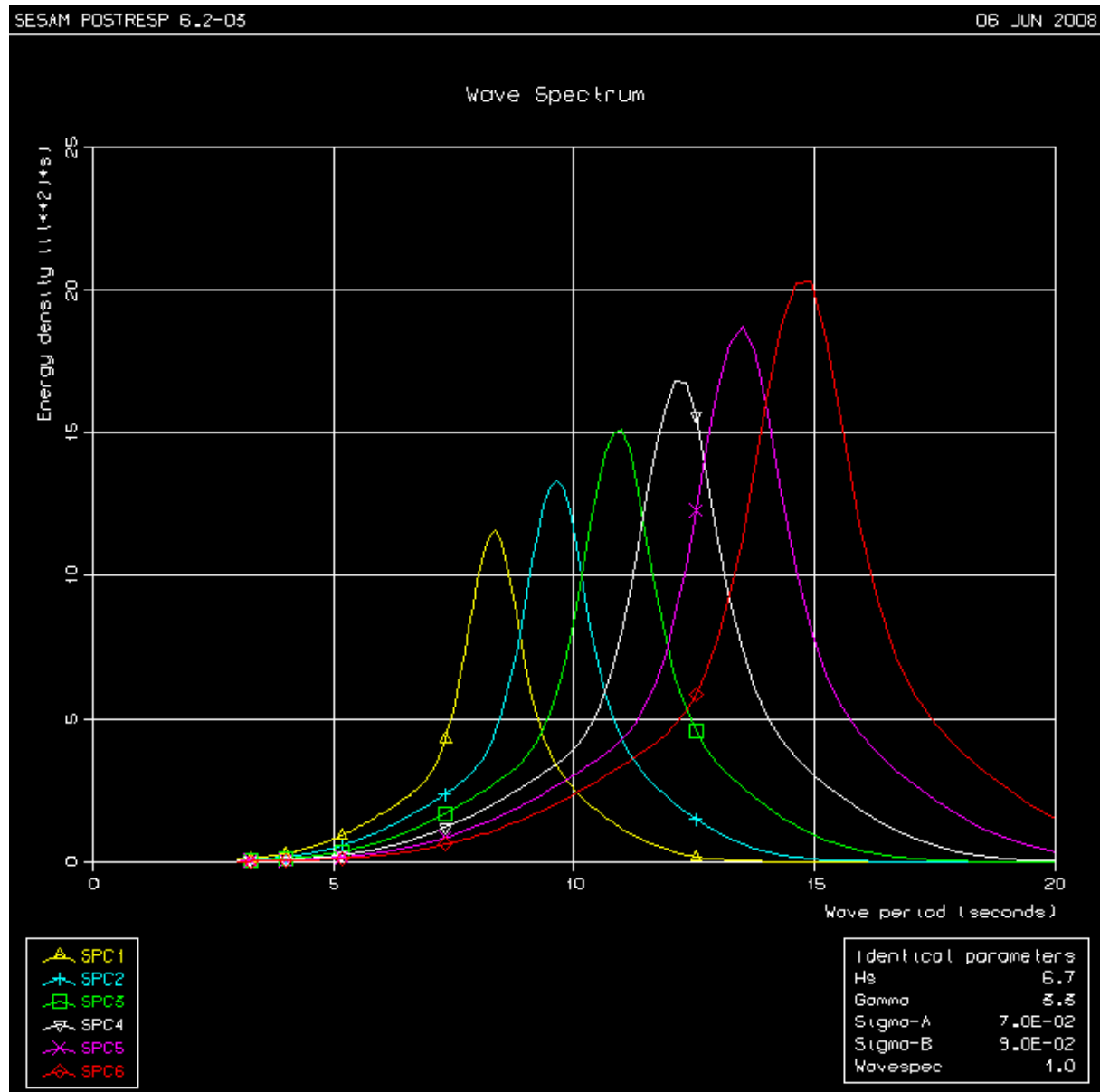

Figure 37: wave spectra

For a JONSWAP spectra, see Appendix B3, the incident wave period, T_p , should be varied between

$$\sqrt{13 \cdot H_s} < T_p < \sqrt{30 \cdot H_s}$$

With a significant wave height of $H_s = 6,7m$ this means that T_p should vary between

$$9,3 \text{ sec} < T_p < 14,2 \text{ sec}$$

For a JONSWAP specter $T_z = \frac{T_p}{1,286}$, then we have

$$7,3 \text{ sec} < T_z < 11,0 \text{ sec}$$

According to this the report uses the following values for T_z , giving us 6 different wave spectra.

- SPC1: $T_z = 6,5 \text{ sec}$
- SPC2: $T_z = 7,5 \text{ sec}$
- SPC3: $T_z = 8,5 \text{ sec}$
- SPC4: $T_z = 9,5 \text{ sec}$
- SPC5: $T_z = 10,5 \text{ sec}$
- SPC6: $T_z = 11,5 \text{ sec}$

When the response spectra are created, POSTRESP finds the design values for the motion, the velocity and the acceleration through short term statistics. By using the desired response spectrum, for example for acceleration, the significant value and the maximum value can be obtained by using the fact that the zeroth moment of the response spectrum is the same as the standard deviation, σ_x , squared.

$$m_0 = \sigma_x^2$$

Where m_j is given by

$$m_j = \int_{-\frac{\pi}{2}}^{\frac{\pi}{2}} \int_0^{\infty} \omega^j |H_x(\omega, \varepsilon)|^2 S(\omega) f(\alpha) d\omega d\alpha$$

From this the significant response, X_s , is decided by

$$X_s = 4\sqrt{m_0} = 4\sigma_x$$

The significant response is characterised as the mean of the one third largest responses in the response spectrum. The design value can then be found by

$$X_{\max} = \sqrt{2}\sigma_x \sqrt{\ln N} = 4,30\sigma_x$$

Here N is the number of zero up-crossings which may be determined from the duration of the short term seastate, D_s , and the mean zero up-crossing response period, T_{z-x} , given by:

$$T_{z-x} = 2\pi \sqrt{\frac{m_0}{m_2}}$$

N will be:

$$N = \frac{D_s}{T_{z-x}}$$

6.3. Analysis results

The results from the tow condition and the stability analysis are found directly in HydroD and will be mentioned here together with complementary figures. The results from the motion response analysis is produced by WADAM and processed and viewed graphically in POSTRESP. The results will be reproduced here, the complementary graphs are included in Appendix C.

6.3.1. Draught and trim

The module static loads, including grillage and seafastening, were applied as local distributed loads to the barge model and a ballast arrangement was found which satisfied the requirements of Chapter 5.2.3.

Some ballast tanks are half full and others are close to full. The half full tanks could cause a negative effect called the “free surface effect” due to motion of the ballast water in the tanks. On the other hand the ballast configuration is needed to keep a heel angle of 0 degrees and the

trim angle close to 0 degrees.

The barge loading condition is presented in Table 5. The ballast plan is given in Appendix A.

Table 5: Loading condition

	Intact stability	Damaged stability (one ballast tank filled, see Appendix A)	Damaged stability (two ballast tanks filled, see Appendix A)
Mean draught	3,08 metres	3,25 metres	3,56 metres
Heel	0 degrees	-1,87 degrees	-5,71 degrees
Trim	0,01 degrees	-0,51 degrees	-1,11 degrees

6.3.2. Intact stability

The intact stability is, as mentioned earlier, the stability in case of no damages to the barge. The first result to look at is the range of stability given by the GZ-curve. This curve is given in Figure 38.

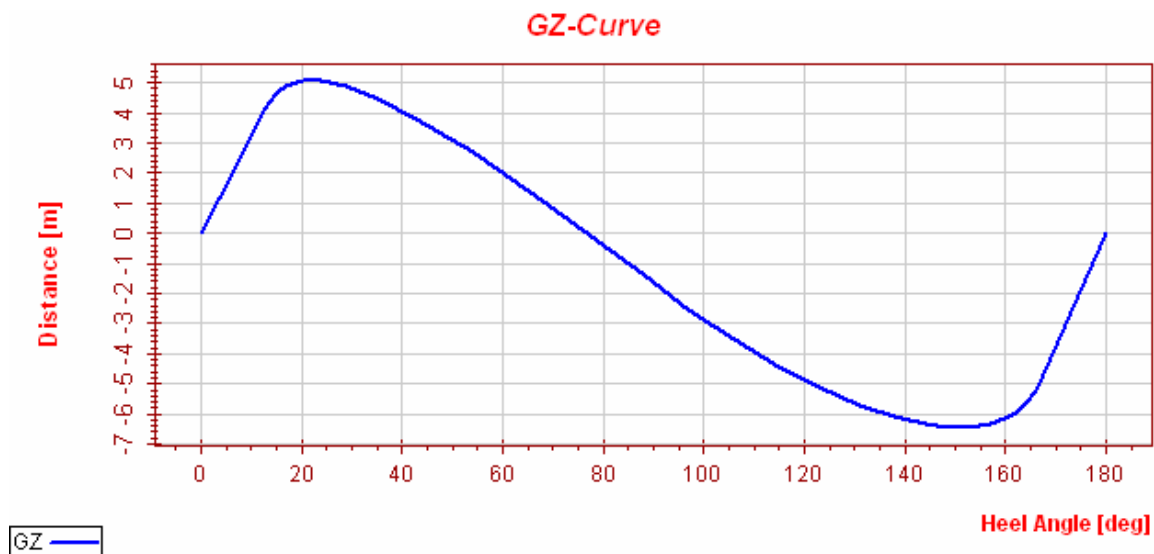

Figure 38: GZ-curve for intact stability

The range of stability is given between the two first zero crossings. It can be seen from Figure 38 that those two zero crossings are 0 degrees and 76,8 degrees. Thereby the range of stability in case of an intact barge is 76,8 degrees.

The metacentric height for this situation is calculated by HydroD to 18,02 metres.

6.3.3. Damaged stability

The damaged stability was found to be most severe when tanks 4P and 5P were flooded. See Appendix A for an overview of the ballast compartments. Figure 39 shows the GZ-curve in case of damage to the barge.

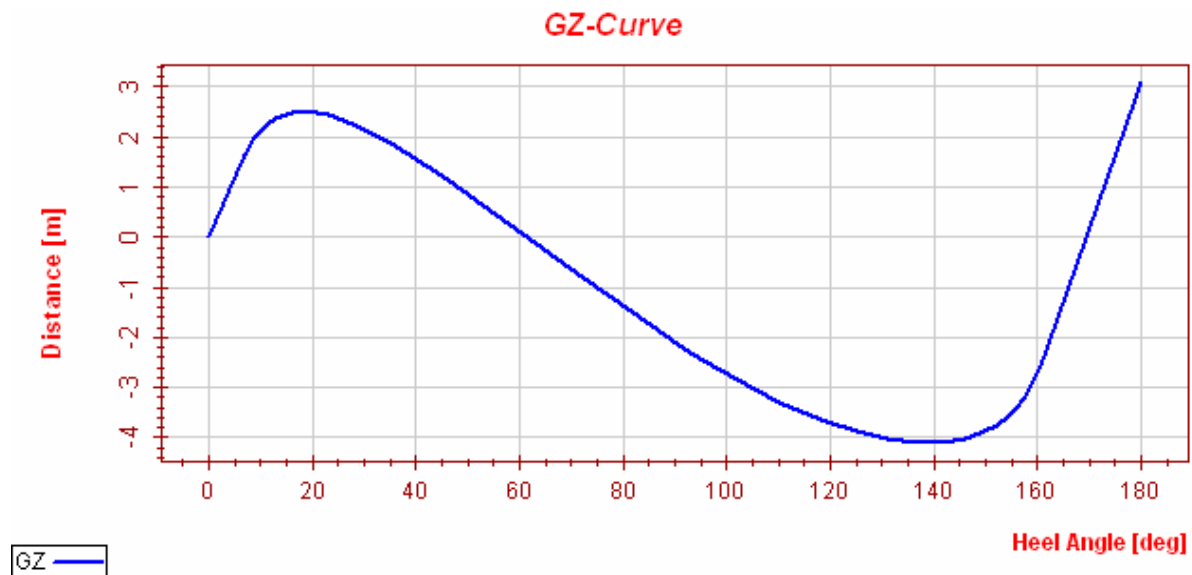

Figure 39: GZ-curve for damaged stability, two tanks.

It can be seen from Figure 39 that the range of stability has been reduced to 61,8 degrees.

The metacentric height has been reduced to 13.5 metres.

6.3.4. Motion response

The maximum accelerations at the center of gravity of the combined structure are found by using short term statistics in POSTRESP which is explained in Chapter 6.2.4. The largest values was found by using SPC 1 which has an incident wave period of 8,4 seconds and a significant wave height of 6,7 metres. The values found are summarized in Table 6.

Table 6: Maximum accelerations at the center of gravity of the barge with cargo.

DOF	Acceleration	
heave	2,88	m/s ²
roll	0,4	rad/s ²
pitch	0,09	rad/s ²
sway	2,33	m/s ²
surge	1,22	m/s ²

These values have to be combined to find the absolute acceleration for each cargo and thereby use this value to design the seafastening.

POSTRESP is used to combine the accelerations by the method shown in Appendix B3. The results given are the maximum values when the variables were wave spectra, the direction of the incident waves and the zero up-crossing periods. It was early clear that the largest values were produced with SPC 1 and for head seas. Appendix C5 shows graphs for each response spectrum for the combined accelerations. Table 7 shows a summary of the maximum accelerations for combined motions. Yaw has been included in the combinations, but it is so small that it gives a very small contribution.

Table 7: Maximum acceleration in x, y and z-direction for combined motions

Cargo	Combined accelerations		
	x [$\frac{m}{s^2}$] surge - yaw - pitch	y [$\frac{m}{s^2}$] sway - yaw - roll	z [$\frac{m}{s^2}$] heave - pitch - roll
Bridge 6	0,67	1,76	3,19
Bridge 7	0,70	1,30	2,42
Bridge 8	0,50	1,41	2,41
Bridge 9	0,68	1,27	2,36
WP Tower North	1,06	1,92	1,72
WP Tower South	1,08	2,11	2,34

Gravity based force will come in addition to the accelerations. Heel angle and pitch angle will decide how large this force will be. The largest values of the response motions can then be used to find the angles where the force becomes largest. Table 8 shows how large the maximum values of the motions are.

Table 8: Maximum motions at the centre of gravity of the barge with cargo.

DOF	Motion
Heave	5,67 m
Roll	23,49 deg
Pitch	8,59 deg
Sway	4,89 m
Surge	4,49 m

It can also be worth to notice that the maximum values of the roll and pitch motions are approximately the same as the simplified criteria given in Noble Denton (2005), this is shown in Table 9.

Table 9: Roll and pitch motion compared to the simplified criteria given by Noble Denton (2005)

DOF	Result	Noble Denton (2005) simplified criteria
Roll	23,49 deg	20 deg
Pitch	8,59 deg	12,5 deg

7. Conclusions

The report has underlined the most important analyses in an offshore transportation with barge. It has tried to split the operation in three which includes the on-loading, the transport and the off-loading. Several considerations of each part have been discussed.

In the on-loading process a lot of methods were presented. The most common method which is the skidding includes some areas of consideration which may cause severe damage if not done properly. The ballast configuration is also a main contributor to the general stability of the barge. This analysis is done to check that the barge floats with a draught and a trim which is proposed as secure in the guidelines. It also checks that the barge does not have a real probability of capsizing. This is done by checking the righting arm of the barge.

In the transport the motion responses to the physical environmental conditions need to be considered. Here resonance and good enough sefastening is two of the most important problems to considerate. If the motions are large and the accelerations become large, fatigue on the cargo, the barge or the sefastening could be a problem. The motion response analysis checks that the period on the barge is not in the same area as the wave period, and also finds the accelerations in each DOF such that the cargo can be securely fastened to the barge.

During off-loading resonance is the main problem. Yet again the natural periods of the barge have to be compared with the wave period.

Further on the report has tried to put more emphasize on two of the most important analyses. This means the stability and the motion response analyses. The theory presented is put together from several sources.

Design criteria are an important part of any analysis. Here guidelines from DNV (1996) and Noble Denton (2005) are summarized and further on used in the case study.

7.1. Conclusions for the case study

The results from the analyses have been obtained and now they need to be compared with the design criteria to see if the operation can safely be carried out.

7.1.1. Draught and trim

Table 10: Conclusion draught and trim, intact stability

	Result	Criteria (Noble Denton, 2005)
Draught	3,08 m	$0,45 \cdot 6,1m < 3,08m < 0,60 \cdot 6,1m$ $2,745m < 3,08m < 3,66m$
Trim	$\approx 0m$	$>0,8$ m
Heel	0 degrees	

It can be seen from Table 10 that the trim criterion is not fulfilled. This should be a minimum of 0,8 metres by the stern. This requirement is an operational requirement during towing. To correct this the ballast tanks needs to be filled such that the barge get its required trim before the towing starts. The towline force may also make the barge get a small trim when this is applied.

The draught is on the correct side of the criterion.

Table 11: Conclusions draught and trim, damaged stability

	Result	Criteria (DNV, 1996)
Mean draught	3,56 m	Remain floating in an acceptable manner.
Trim	-0,9 m	
Heel	-5,7 degrees	

It can be seen from Table 11 that the heel in damaged condition is quite large. This is due to the fact that a scenario with two damaged adjacent tanks is used. This is a conservative scenario, and as long as it is floating with this damage it will float in an acceptable manner with one tank damaged.

7.1.2. Intact stability

The range of positive stability is 76,8 degrees, which is greater than the minimum required by both DNV (1996) and Noble Denton (2005), thereby the static intact stability criterion is satisfied.

For dynamic intact stability, the wind area ratio between the righting and the heeling moment arm, to the 2nd intercept, is 7,6. The criterion from both Noble Denton (2005) and DNV (2005) is 1,4. Hence, the intact dynamic stability criterion has also been satisfied.

The metacentric height is 18,01 metres which is larger than the criterion which recommends a

metacentric height of more than 1 metre.

7.1.3. Damaged stability

The positive range of stability for the two adjacent compartments damaged which gives worst stability is 61,8 degrees. The wind area ratio between the righting and the heeling moment arm, to the 2nd intercept, is 15,86 which satisfies the damaged stability criterion.

The metacentric height is 13,5 metres which is larger than the criterion which recommends a metacentric height of more than 1 metre.

This is a conservative way of checking the barge's damaged stability. To get a less conservative result we should have checked the GZ-curve for one damaged compartment.

7.1.4. Motion response

The motion response is calculated by using wave spectra according to the 10 year monthly extremes for the area and season. The accelerations obtained may , in addition to the gravity force from heel and trim, be used to design the seafastening for each module, see Chapter 4.4.

8. References

Barrass, C.B. and Derrett, D.R. (2006), *Ship stability for masters and mates*, Butterworth-Heinemann, Oxford

Biran, Adrian (2003), *Ship hydrostatics and stability*. Butterworth-Heinemann, Oxford

Brennen, C.E. (1982), *A review of added mass and fluid inertial forces*, Naval civil engineering laboratory. Port Hueme, California
<http://authors.library.caltech.edu/233/01/BRE052.pdf> - 18.04.08

Brown & Root Vickers (1990), *Transportation Procedure*, Prepared by Floating structures department, Civil structural & marine engineering, Document No. 062-7234-ST-77-001-A,

Det Norske Veritas (1996), *Rules for planning and execution of marine operations*, Høvik

- Part 1 Chapter 2, *Planning of operations*
- Part 1 Chapter 3, *Design Loads*
- Part 2 Chapter 2, *Towing*

Det Norske Veritas (2005a), *Genie user manual*, Høvik

Det Norske Veritas (2008), *HydroD user manual*, Høvik

Det Norske Veritas (2007), *POSTRESP manual*

Det Norske Veritas (2005b), *WADAM user manual*, Høvik

Gillmer, T.C and Johnson, B (1982), *Introduction to naval architecture*, E. & F. N. Spon Ltd., London

Goda, Yoshimi (2000), *Random seas and design of maritime structures*, Advanced series on ocean engineering – Volume 15, World Scientific Publishings, Singapore.

Gran, Sverre (1992), *A course in ocean engineering*. Elsevier, Amsterdam

Grant, Colin (2005), *Oceanographic and meteorological design data summary – Valhall field*, BP Exploration, Report No: S/EPT/073/04

Gudmestad, Ove Tobias (2007), *Stabilitet*, Lecture notes in Marine Technology 2007.

University of Stavanger.

Lamb, H. (1932), *Hydrodynamics*. Cambridge University Press. London.

Macsween, John A. (2004), *Technical and marine aspects while planning and executing the transportation of heavy lift cargoes*, Malin Marine <http://www.malinmarine.com/downloads/IMS2004.pdf> - 11.03.08

Noble Denton (2005), *General guidelines for marine transportations*, 0030/NDI Rev 2, London

Norges offentlige utredninger (2000), *Hurtigbåten MS Sleipners forlis 26. november 1999*, Kap. 3.2.5 <http://www.regjeringen.no/nb/dep/jd/dok/NOUer/2000/NOU-2000-31/5/2/5.html?id=362602> – 11.03.08

NORSOK (2007), *N-003 Actions and action effects*, Edition 2, Standards Norway, Norway

Ochi, M.K (1998), *Ocean Waves: The Stochastic Approach*, Cambridge University Press. London.

Phelps, B.P. (1995), *Ship structural response analysis: spectra and statistics*, Department of Defence - Defence science and technology organisation, Australia <http://dSPACE.dsto.defence.gov.au/dSPACE/bitstream/1947/4339/1/DSTO-TR-0183.pdf> - 08.05.08

Rao, Singiresu S. (2005), *Mechanical Vibrations*, Prentice Hall. Singapore.

Rawson, K.J. and Tupper, E.C. (2001a), *Basic ship theory, Volume 1*, Butterworth-Heinemann, Oxford

Rawson, K.J. and Tupper, E.C. (2001b), *Basic ship theory, Volume 2*, Butterworth-Heinemann, Oxford

Suleiman, Baha M. (2000), *Identification of finite-degree-of-freedom models for ship motions* http://scholar.lib.vt.edu/theses/available/etd-12132000-213853/unrestricted/Baha_Suleiman.pdf - 12.03.08

Tupper, E.C. (2004), *Introduction to naval architecture*, Elsevier. Amsterdam

Wilson, James F. (1984), *Dynamics of offshore structures*, Wiley Interscience. New York

Internet:

1. <http://www.earthtimes.org/articles/show/155522.html> - 11.03.08
2. International Merchandise Trade, Australia, Concepts, Sources and Methods, Glossary, Australian Bureau of Statistics.-
<http://www.abs.gov.au/ausstats/abs@.nsf/0/6B7D040A646F264ECA256A5B001BD777?Open&Highlight=0,warehouse> – 11.03.08
3. Buoyancy – Archimedes' Principle - <http://home.flash.net/~table/gasses/archem.htm> - 31.03.0

- BLANK SIDE -

A Appendix: Overview of ballast tanks

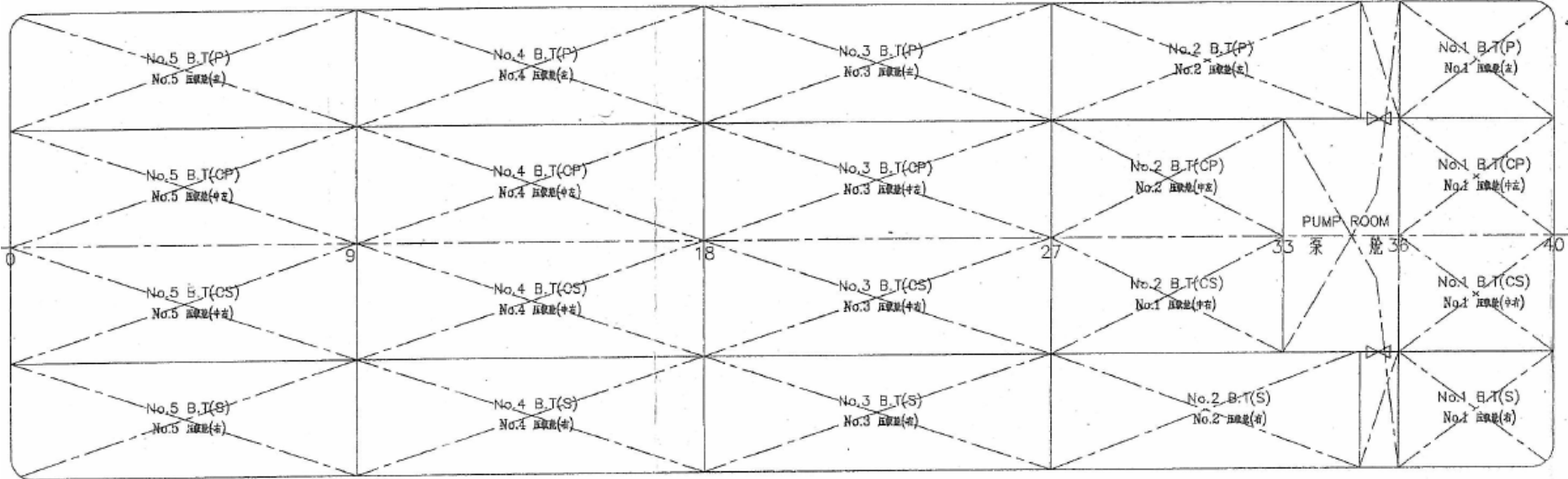

Figure 40: A general overview of the ballast tanks

Ballast configuration

Ballast tank	tonnes	Capacity	%
1S	2	264	0,01
1P	2	264	0,01
1SC	117,52	264	0,45
1PC	117,52	264	0,45
2S	35	872	0,04
2P	35	872	0,04
2SC	35	872	0,04
2PC	35	872	0,04
3S	767,4	872	0,88
3P	854,6	872	0,98
3SC	35	872	0,04
3PC	35	872	0,04
4S	35	872	0,04
4P	35	872	0,04
4SC	392	872	0,45
4PC	671,44	872	0,77
5S	30	731	0,04
5P	30	731	0,04
5SC	21	439	0,05
5PC	21	439	0,05

Table 12: The ballast configuration

Table 12 shows how the ballast is distributed throughout the barge's ballast tanks. Ballast tank shows where the tank is located in Figure 40, tonnes shows how much sea water in tonnes each tank is filled with. The capacity is the total capacity of the each tank in tonnes and % is how many % each tank is filled up.

B Appendix: Analysis tools

This appendix is trying to explain the computer programs used in the analyses process. The information is found in the manuals for each program (DNV, 2008, 2007 and 2005 a and b).

B1 GeniE

GeniE is a tool for design and analyses of offshore and maritime structures made up of beams and plates. It is based upon the use of concepts to represent the physical structure and the equipment it supports. Modelling, analysis, and results processing are performed from the same graphical user environment.

Previous design and analysis software was made with an end goal of performing structural assessment based on Finite Element Method (FEM). These software solutions solved many problems, but there were some problems with the integration with CAD software and rule based capacity check software. It was very hard or impossible to communicate between these three domain boundaries. The consequence was excessive and costly re-modelling within each domain.

GeniE uses what is called concept modelling. This feature provides a means of overcoming many of these issues because the user's design intent is better captured. Instead of representing the structure with nodes, elements, faces or edges it is now possible to model the structure with whole deck plates and segmented beams as single design concepts. Information about attributes, like section profiles and hydrodynamic properties, as well as connectivities to other structural members, is now included in the concepts.

The model is thereby made independent of which analysis method is going to be used. GeniE has also engineering knowledge built into the program. This ensures quality of the model and the results.

The case study in this report uses GeniE only as a modelling tool. A panel model is made and imported into HydroD for subsequent stability and hydrodynamic analysis.

B2 HydroD

HydroD is an interactive application for computation of hydrostatics and stability, wave loads and motion response for ships and offshore structures. The program is used to model the environment and prepare input data for hydrostatic and hydrodynamic analysis.

Like mentioned earlier GeniE is used to make the model which later is imported to HydroD as a finite element model. In HydroD there are four different hydro model configurations that may be handled, namely panel models, Morison models, composite models and dual models, see Figure 41.

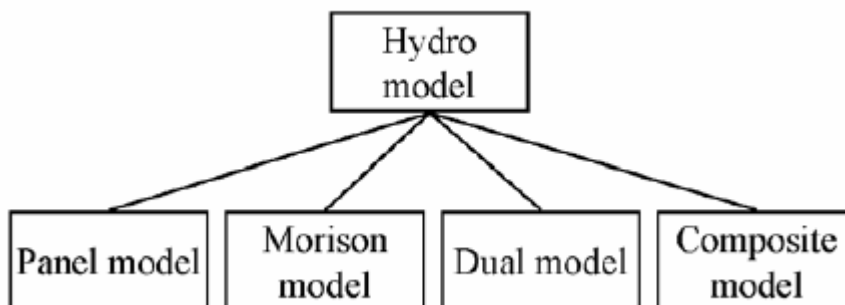

Figure 41: Four different hydro models (DNV, 2005b)

The panel model is chosen if the model contains large submerged volumes on which the user wants to calculate hydrostatic and hydrodynamics forces from potential theory.

The Morison model consists of beam elements on which the user want to apply Morison's equation to calculate hydrodynamic and hydrostatic forces and motion response.

If the user wants to apply both Morison's equation and 3D potential theory on different parts of the model, then composite model configuration is to be used.

And at last if the user wants to apply both Morison and potential theory, then dual model configuration is chosen.

This report uses a panel model to calculate the hydrostatic and hydrodynamic forces.

HydroD is, as mentioned earlier, used to calculate both hydrostatics and hydrodynamics. These two processes are two parts of the program.

B2.1 Stability

The stability is calculated by using the panel model created in GeniE. After having chosen the panel model, the program guides the user through the parameters needed for the calculation. Everything from the environment to the ballast tanks and the filling fraction of these is given. The initial stability and damaged stability can then be calculated. The results are given in a GZ-curve among other curves. The metacentric height is also given in the results.

B2.2 WADAM

This chapter of the appendix is given by the manual of WADAM (DNV, 2005b).

The global response feature in WADAM computes the response of fixed and floating structures due to wave loads. Results that can be computed are forces and response transfer functions assuming rigid bodies. The results can be transferred to the statistical postprocessor POSTRESP for graphics presentation and further results processing through a results interface file.

The statistical postprocessing in POSTRESP consists of statistical analysis of transfer functions including calculation of response spectra and short and long term statistics. POSTRESP also includes the option to calculate the equation of motion from the global matrices and exciting forces transferred from WADAM.

A system consisting of a hydro model and a mass model is needed to perform a global response analysis. The hydro model may consist of a panel model, a Morison model or a combination of these two model types. The hydro model represents different types of hydrostatic and hydrodynamic loads. The case study in this report consists of a panel model.

If the system is specified to be floating and the global response analysis includes calculation of motions, then a mass model is required. The mass model has information of the total mass of the system among other important values.

The motion responses for a hydro model are obtained by solving the equations of motion for a set of wave frequencies and heading angles. The added mass, damping and restoring matrices used in the equations of motion may be calculated by applying Morison's equation, the

potential theory or the composite method. This report is based on the potential theory which is used together with the panel model.

The global response results calculated by WADAM are reported with respect to a motion reference point which is located at the intersection between the still water level and a vertical line through the common origin of the models used in the analysis. The results of interest available from a global response analysis of a hydro model include transfer functions for motion responses.

B3 POSTRESP

The theory included in this part of the appendix is given by DNV (2007)

To get the response spectra needed to obtain a result the transfer function (RAO) need to be established and a wave spectrum need to be defined. The transfer function is imported to POSTRESP from a Results Interface File created in WADAM. The wave spectrum are defined below.

Wave spectrum

The report uses a JONSWAP wave spectrum. The JONSWAP spectrum can be described as a function of the four parameters $(\alpha, \omega_p, \gamma, \sigma)$ or alternatively by the four parameters $(H_s, T_z, \gamma, \sigma)$.

In the first form the spectrum can be written as

$$S(\omega, \alpha, \omega_p, \gamma, \sigma) = \alpha g^2 \omega^{-5} \exp\left(\frac{-5}{4} \left(\frac{\omega}{\omega_p}\right)^{-4}\right) \gamma^\alpha$$

Where

$$\alpha = \exp\left(\frac{-1}{2} \left(\frac{\omega - \omega_p}{\sigma \omega_p}\right)^2\right)$$

The relation between (α, ω_p) and (H_s, T_z) can be found by computing m_0 and m_2 . From the spectrum definition above we see that the moments can be written as

$$m_0 = \alpha g^2 \omega_p^{-4} F_0(\gamma, \sigma)$$

$$m_2 = \alpha g^2 \omega_p^{-2} F_2(\gamma, \sigma)$$

Now H_s and T_z can be computed

$$H_s(\alpha, \omega_p) = 4\sqrt{m_0}$$

$$T_z(\alpha, \omega_p) = 2\pi \sqrt{\frac{m_0}{m_2}}$$

And the inverse relations

$$\alpha(H_s, T_z) = \left(\frac{F_0}{F_2}\right) \left(\frac{H_s \pi^2}{g T_z^2}\right)^2$$

$$\omega_p(H_s, T_z) = 2\pi \omega T_z^{-1} \sqrt{\frac{F_0}{F_2}}$$

Transfer functions and phase definitions

The transfer functions from WADAM describe responses for bodies in harmonic waves. The reported responses are normalized with respect to the incident wave amplitudes. With a transfer function $H(\omega, \beta)$ the corresponding time dependent response variable $R(\omega, \beta, t)$ can be expressed as

$$R(\omega, \beta, t) = A \operatorname{Re}[|H(\omega, \beta)| e^{i(\omega t + \phi)}]$$

Where

- A is the amplitude of the incoming wave
- ω is the frequency of the incoming wave
- β describes the direction of the incoming wave
- ϕ is the phase
- t denotes time

Where $|H|$ is the amplitude of the transfer function. The phase lead ϕ of the response relative to an incident wave with the wave crest at the origin of the global coordinate system is shown in Figure 42.

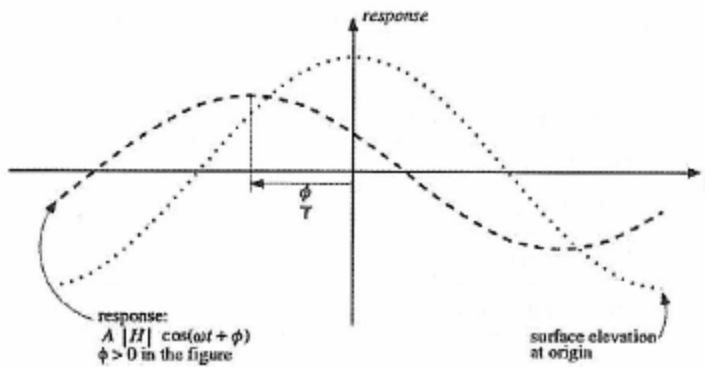

Figure 42: Definition of the phase between the response and the incident wave (DNV, 2005b)

The transfer functions for rigid body motion due to the incident waves are reported for each body for all the combinations of wave frequencies and heading angles.

Short term response

The responses of an irregular sea state may, as mentioned earlier, be calculated by multiplying the square of the transfer function with the wave spectrum.

The c^{th} order of the spectral moment is then given by

$$m_c = \int_{-\frac{\pi}{2}}^{\frac{\pi}{2}} \int_0^{\infty} \omega^c |H(\omega, \beta)|^2 S(\omega) f(\alpha) d\omega d\alpha$$

The significant response, X_s , for the response variable is defined as the mean of the one-third largest responses in the response spectrum. This is related to the zero moment m_0 by

$$X_s = 4\sqrt{m_0}$$

The mean zero up-crossing period, T_{z_x} , of the response is related to the zero order and the second order moments of the response spectrum and is given by

$$T_{z-x} = 2\pi \sqrt{\frac{m_0}{m_2}}$$

The distribution of the response maxima in a short term seastate is described using the Rice distribution function.

$$F_s(x) = \Phi\left(\frac{x}{\varepsilon\sigma_x}\right) - \sqrt{1-\varepsilon^2} \Phi\left(\frac{\sqrt{1-\varepsilon^2}}{\varepsilon} \frac{x}{\sigma_x}\right) e^{-\frac{1}{2}\left(\frac{x}{\sigma_x}\right)^2}$$

Where $\Phi()$ is the normal probability integral, σ_x is the standard deviation of the response, and ε is the spectral width parameter given by

$$\varepsilon = \sqrt{1 - \frac{m_2^2}{m_0 m_4}}$$

The most probable largest response X_{\max} occurring within a time interval of N_c is approximately given by

$$X_{\max} = \sqrt{2}\sigma_x \sqrt{\ln(\sqrt{1-\varepsilon^2} N_c)}$$

In the case of a narrow banded spectrum, i.e. $\varepsilon=0$, the most probable largest response is given by

$$X_{\max} = \sqrt{2}\sigma_x \sqrt{\ln N_s}$$

Where N_s represents the number of zero up-crossings in the short term sea state. N_s is given by

$$N_s = \frac{D_s}{T_{z-x}}$$

Combining transfer functions

The transfer functions (RAO) are given by the analysis in WADAM, but they are limited to the basic motions in the six degrees of motion. It is usually necessary to combine the functions to describe other motions in the x, y and z directions, at arbitrary locations on the

structure. POSTRESP gives the opportunity to combine some standard combinations.

The absolute motion in the z-direction is given by:

$$H_{AM(z)} = H_{heave} - xH_{pitch} + yH_{roll}$$

The relative motion in the z-direction is given by:

$$H_{RM(z)} = H_{AM(z)} - H_{wave(z)}$$

The absolute motion in the y-direction is given by:

$$H_{AM(y)} = H_{sway} + xH_{yaw} - zH_{roll}$$

The absolute motion in the x direction is given by:

$$H_{AM(x)} = H_{surge} - yH_{yaw} + zH_{pitch}$$

Here x, y and z denotes the distance from the centre of gravity of the structure to the point of interest and H is the transfer function for the relevant DOF. The acceleration due to yaw is so small that it is usually neglected.

Transfer functions for velocity and the acceleration may be obtained from the motion transfer functions, H_M , using the following relationships:

$$H_V = i\omega H_M$$

$$H_A = -\omega^2 H_M$$

Which clearly is the same as differentiate the motion transfer function once for velocity and twice for acceleration.

C Appendix: Results from POSTRESP

C1 Response variables

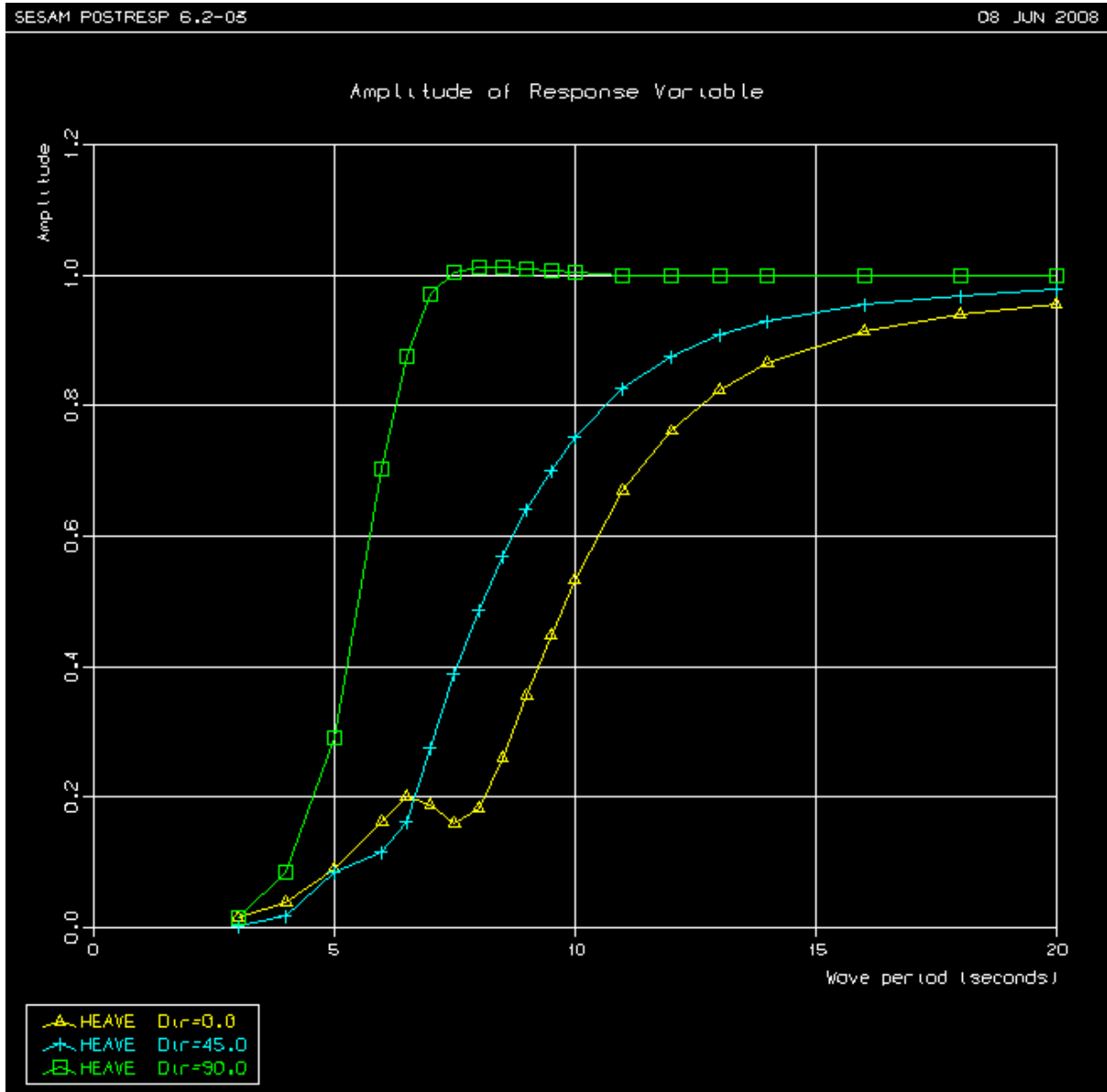

Figure 43: Amplitude of response variables in heave

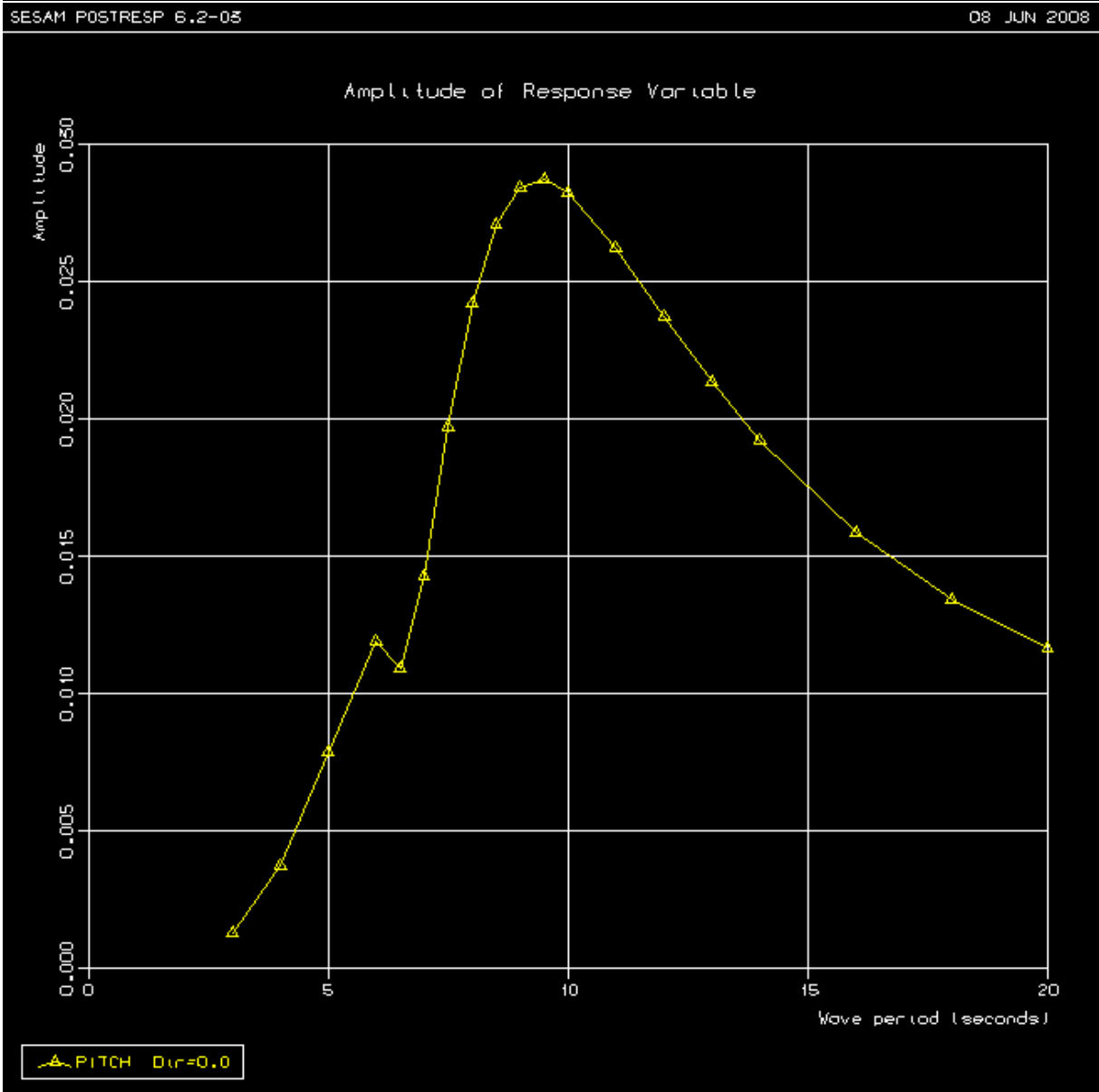

Figure 44: Amplitude of response variables in pitch

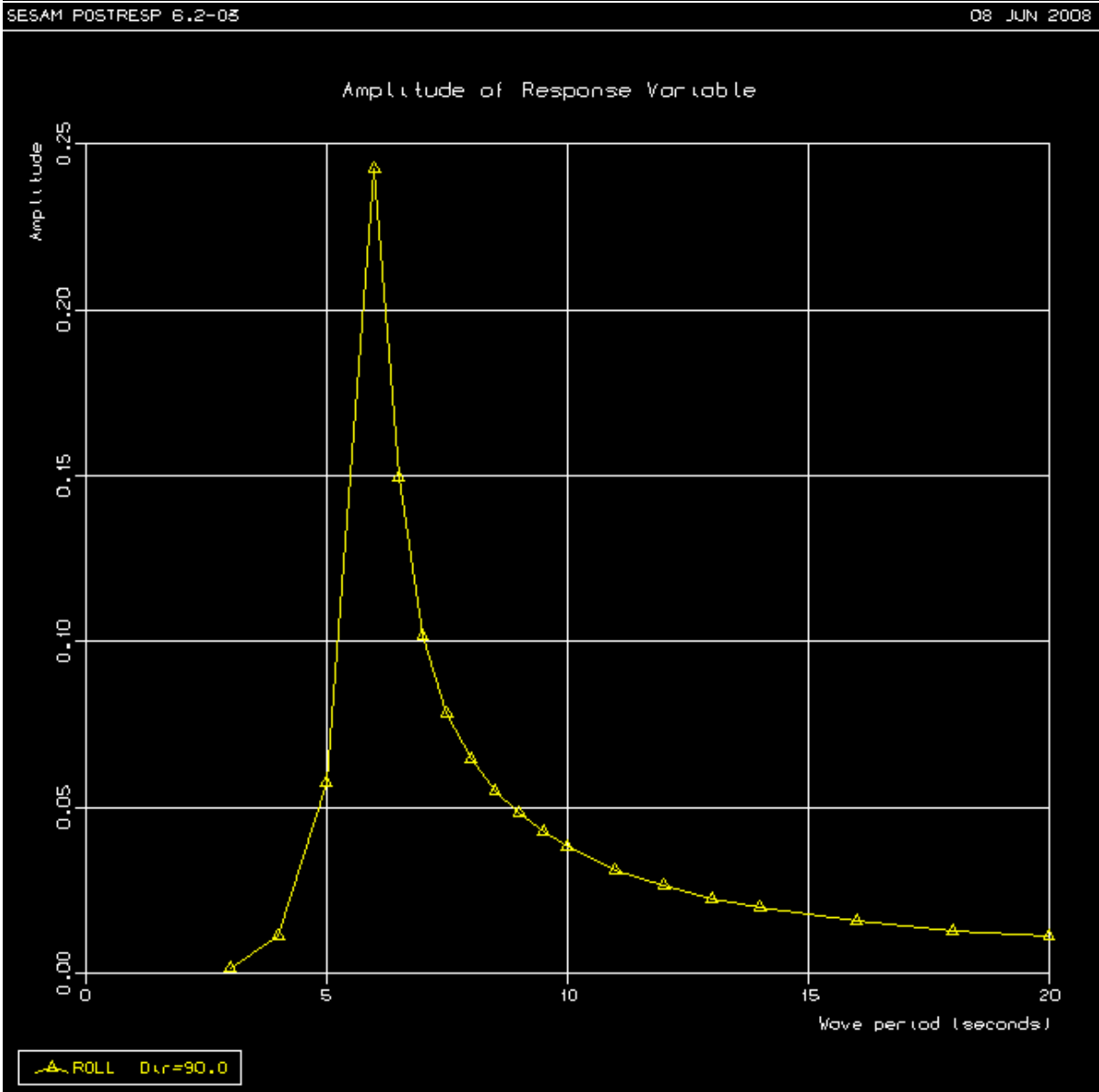

Figure 45: Amplitude of response variables in roll

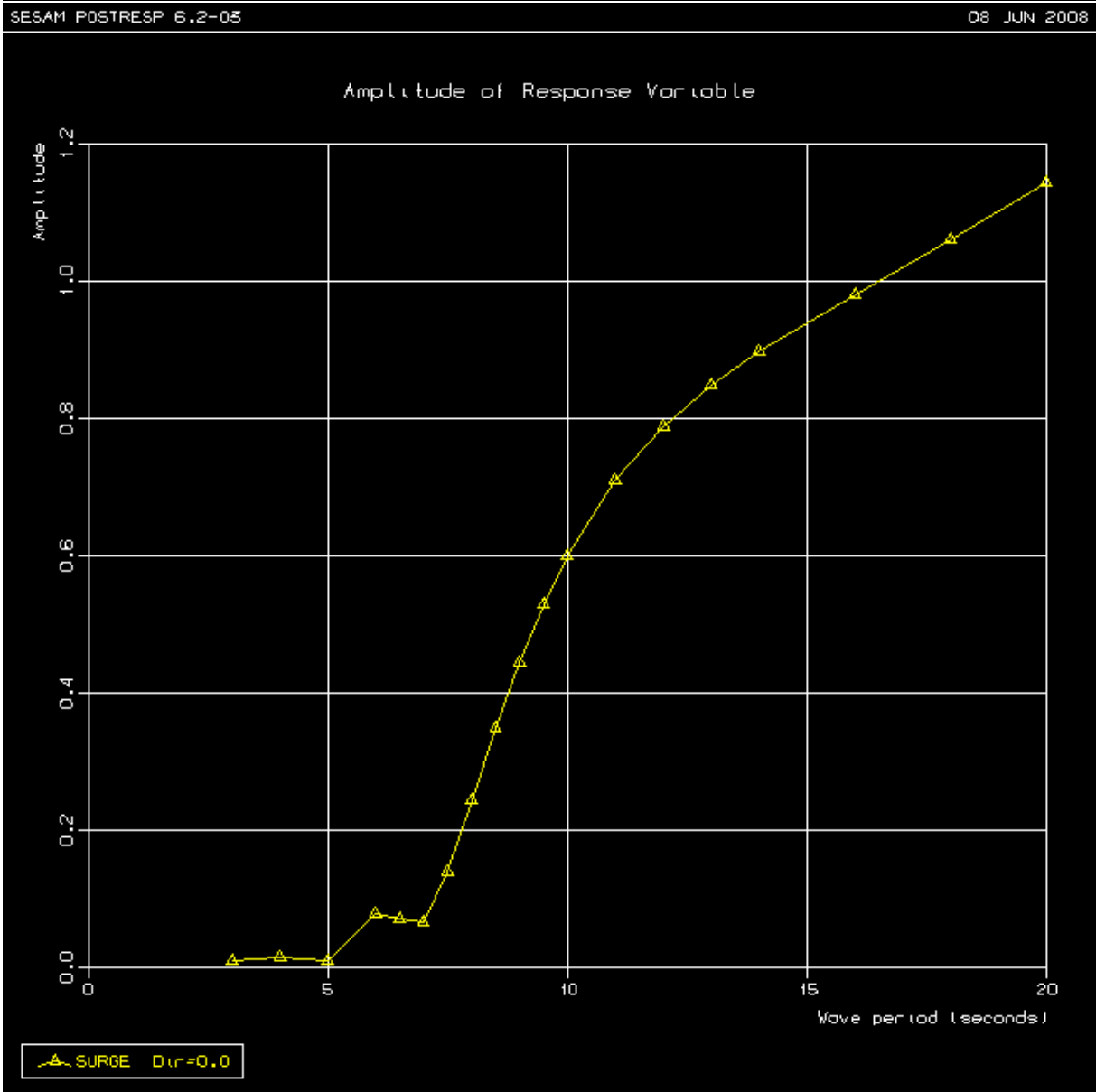

Figure 46: Amplitude of response variables in surge

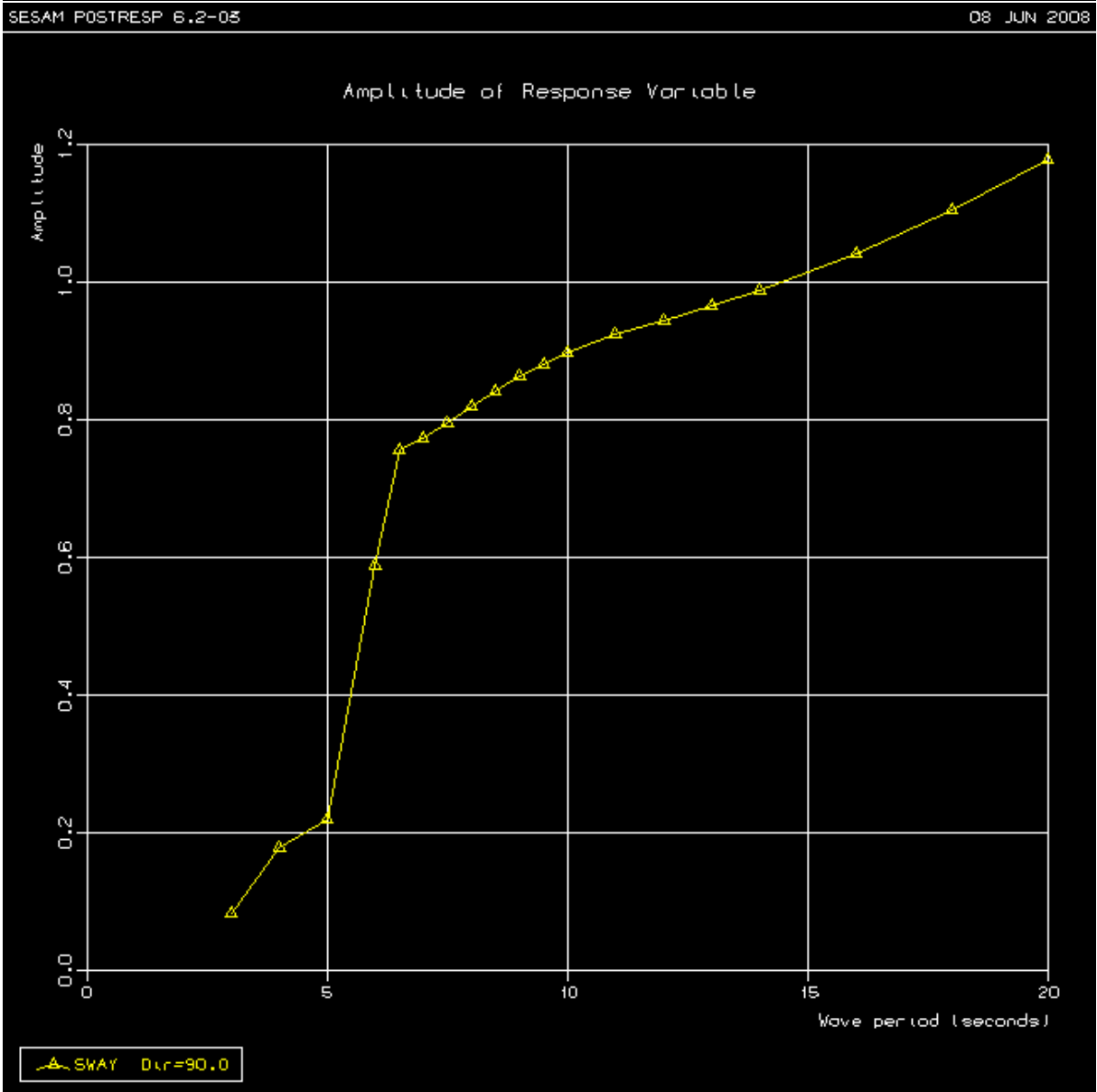

Figure 47: Amplitude of response variables in sway

C2 Wave spectra

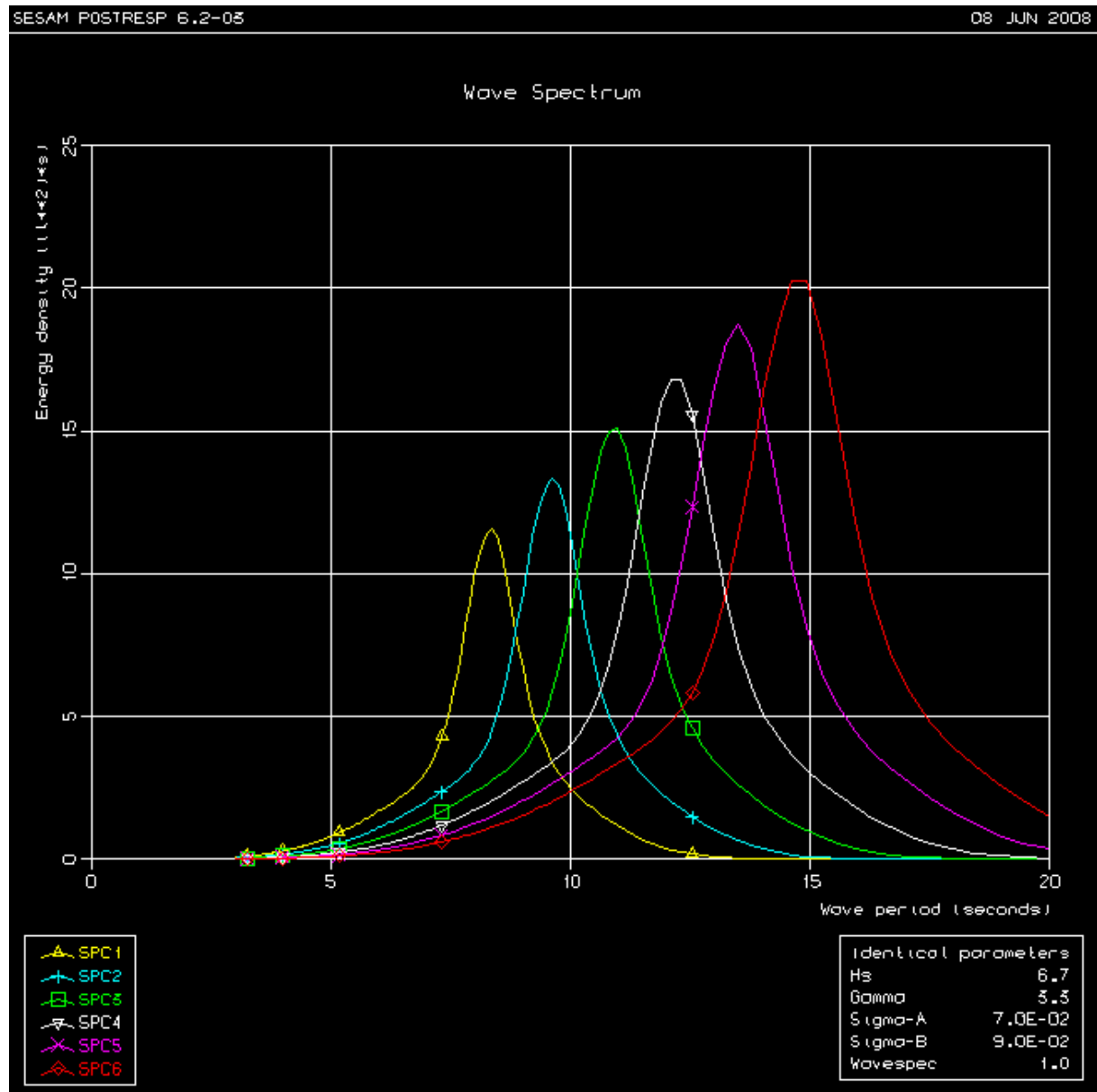

Figure 48: Wave spectrum for a significant wave height of 6,7 m and with a varying zero up-crossing period, $6,5 \text{ s} < T_z < 11,5 \text{ s}$

C3 Response spectrum for motion

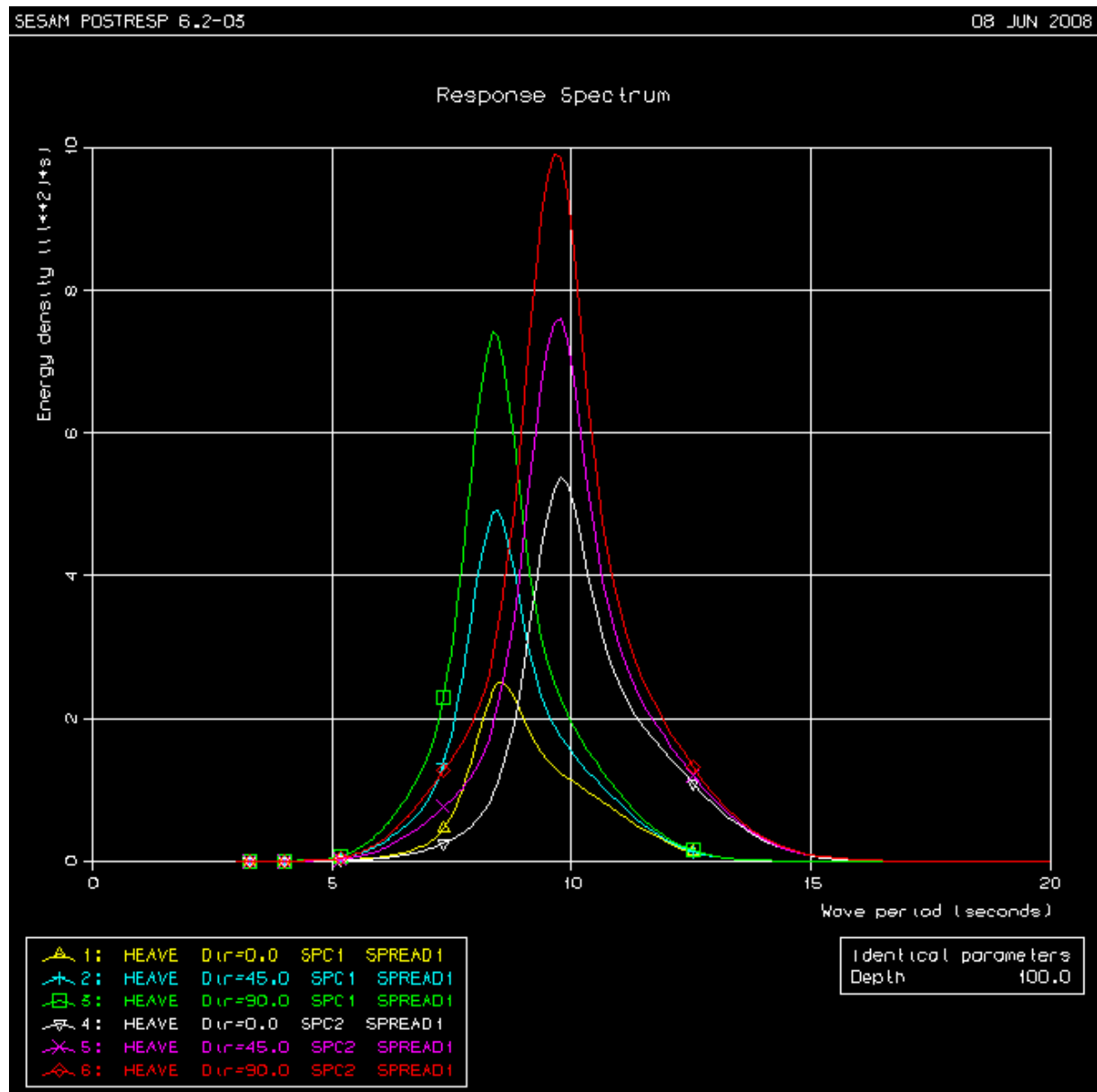

Figure 49: Response spectrum heave for $T_z=6,5$ s and $T_z=7,5$ s, and $H_s=6,5$ m

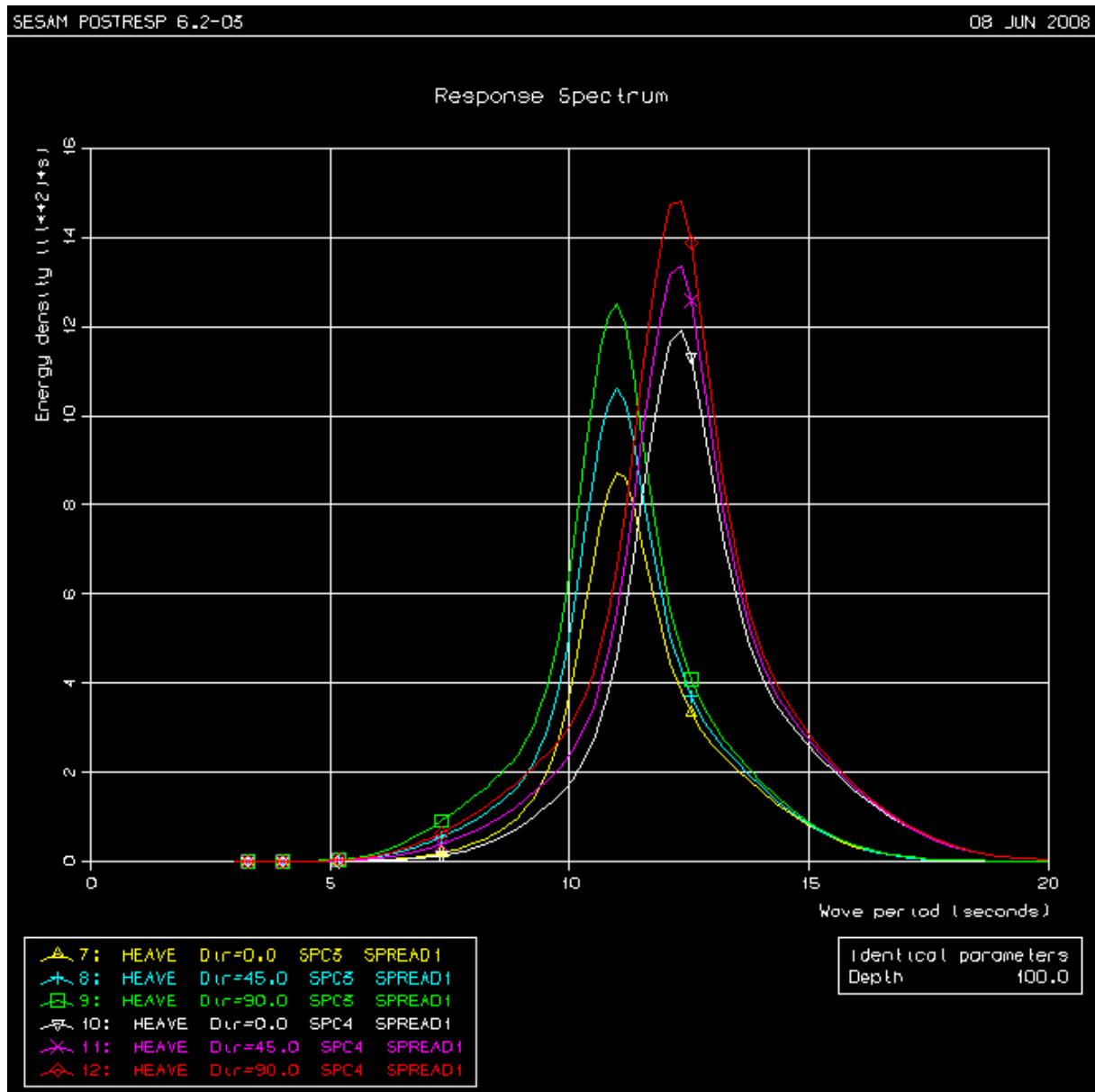

Figure 50: Response spectrum heave for $T_z=8,5$ s and $T_z=9,5$ s, and $H_s=6,5$ m

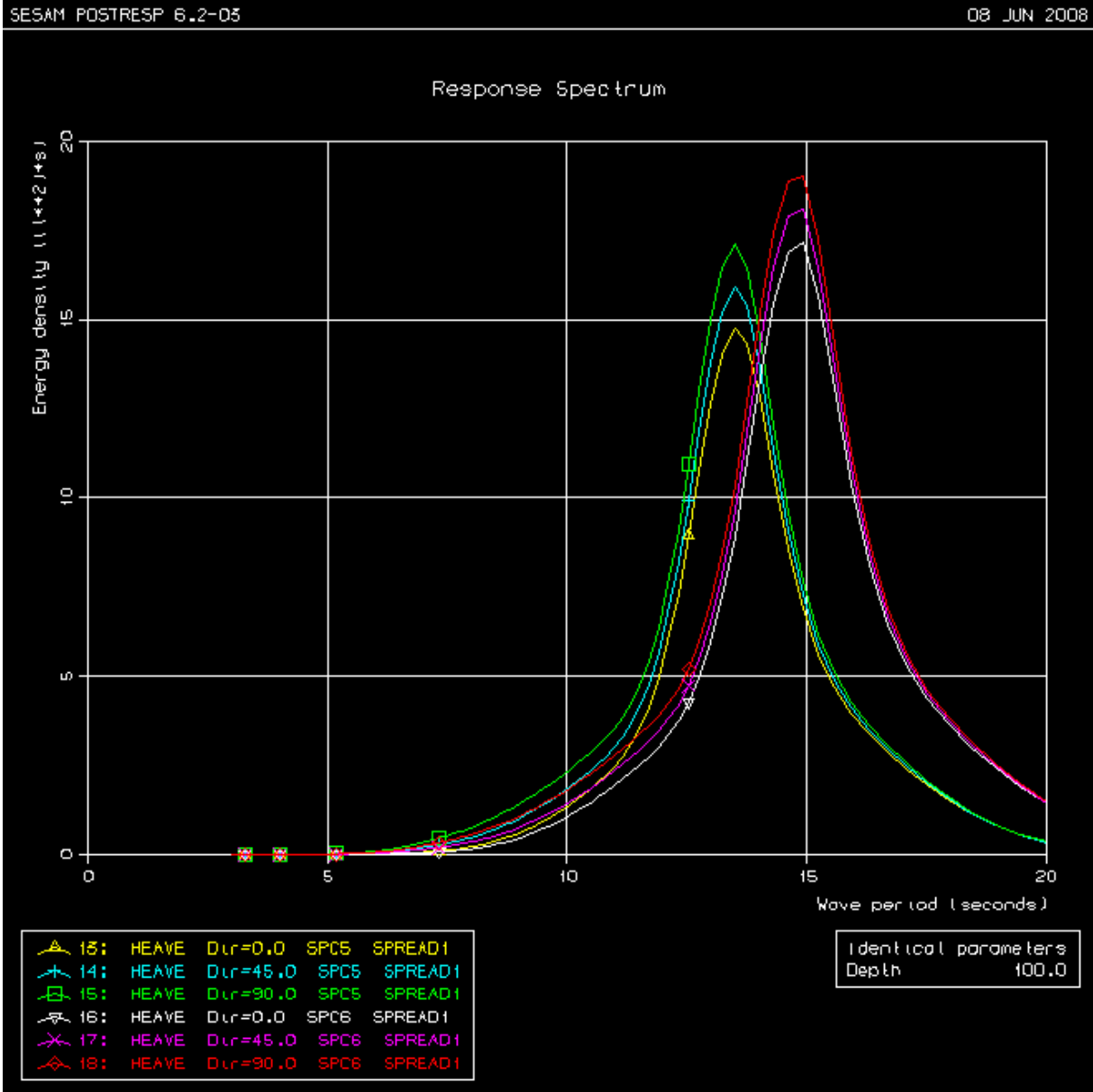

Figure 51: Response spectrum heave for Tz=10,5 s and Tz11,5s, and Hs=6,5m

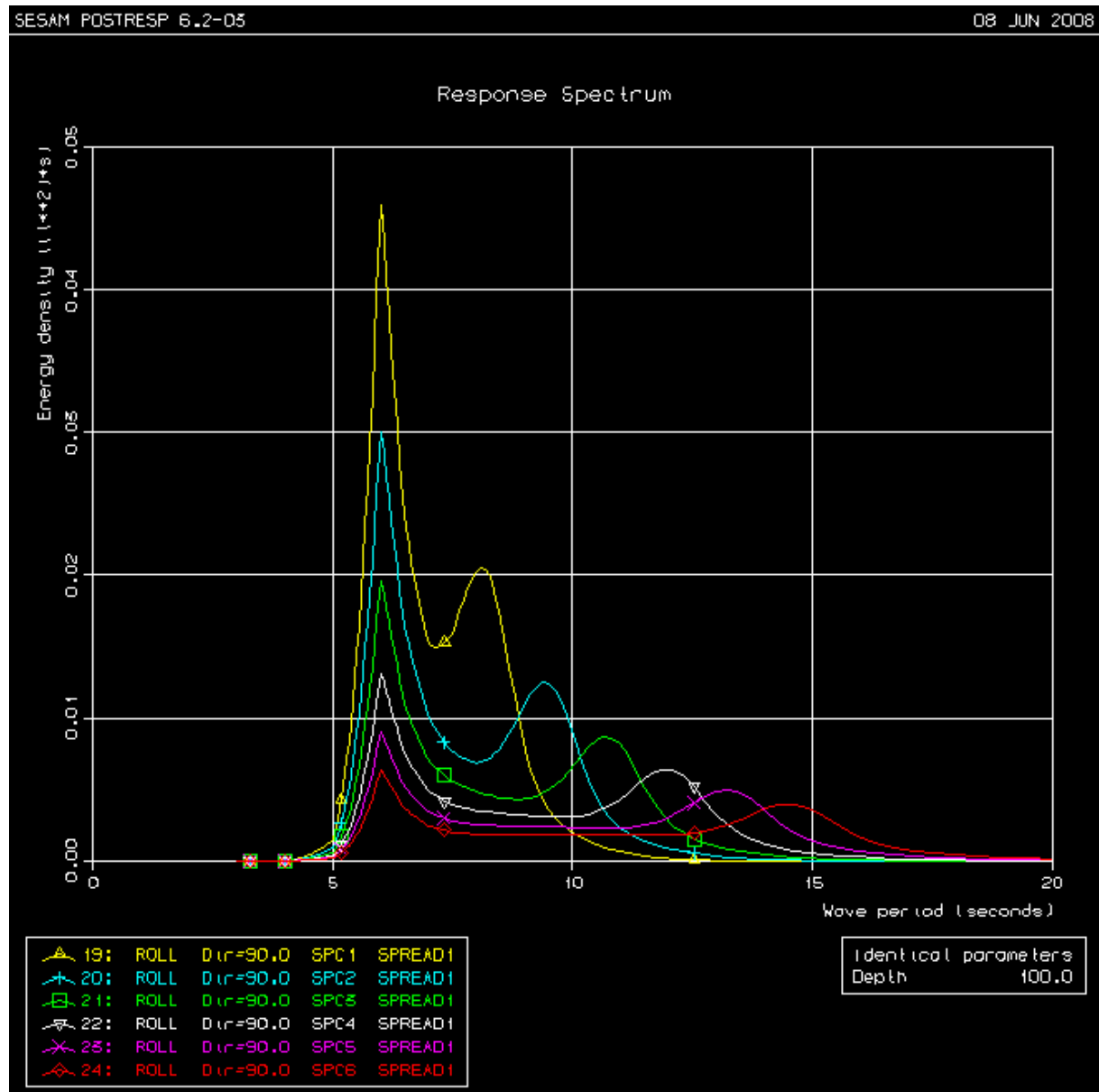

Figure 52: Response spectrum roll for $6,5 \text{ s} < T_z < 11,5 \text{ s}$, and $H_s=6,5\text{m}$

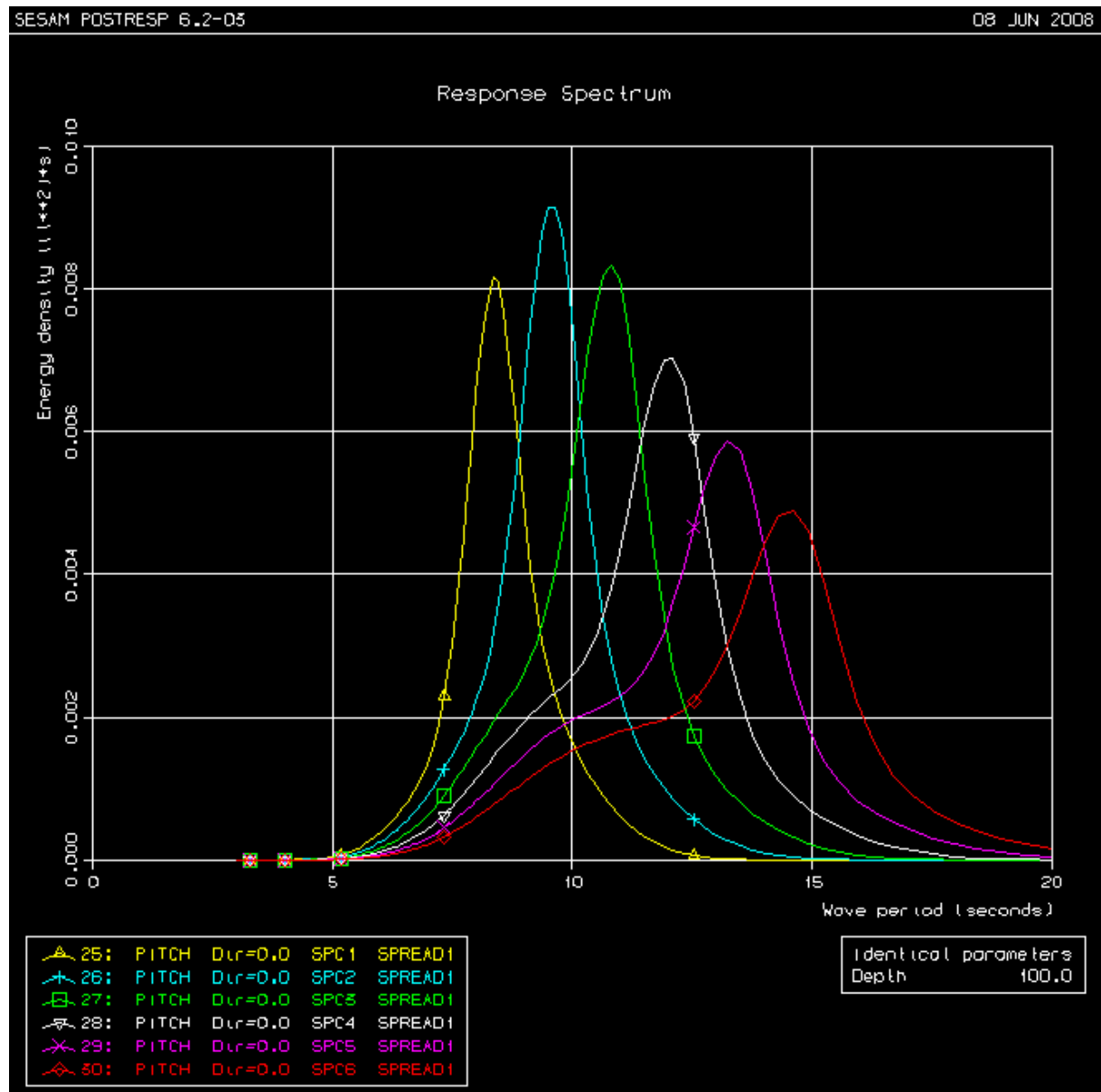

Figure 53 Response spectrum pitch for $6,5 \text{ s} < T_z < 11,5 \text{ s}$, and $H_s=6,5\text{m}$

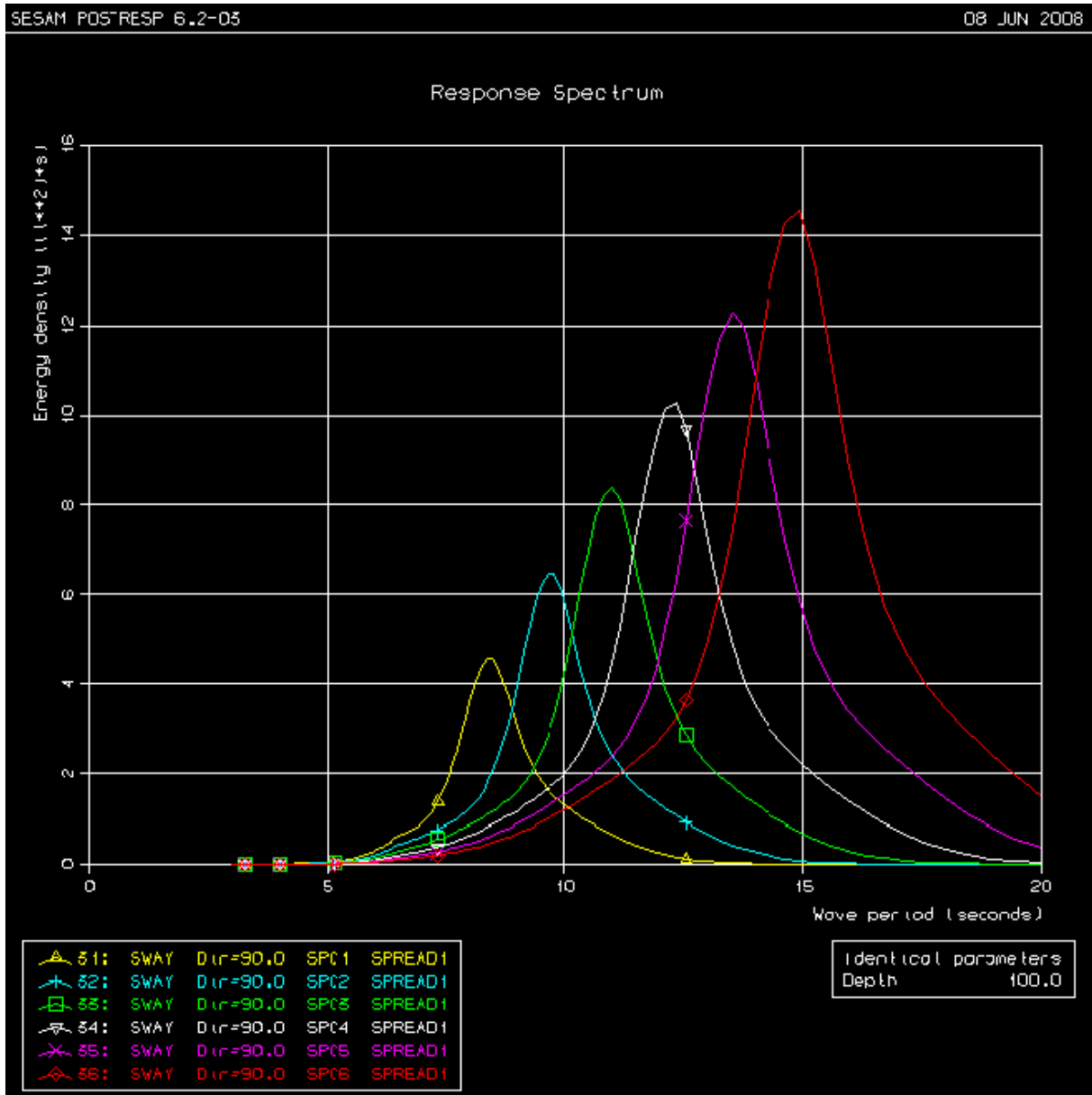

Figure 54: Response spectrum sway for 6,5 s < Tz < 11,5 s, and Hs=6,5m

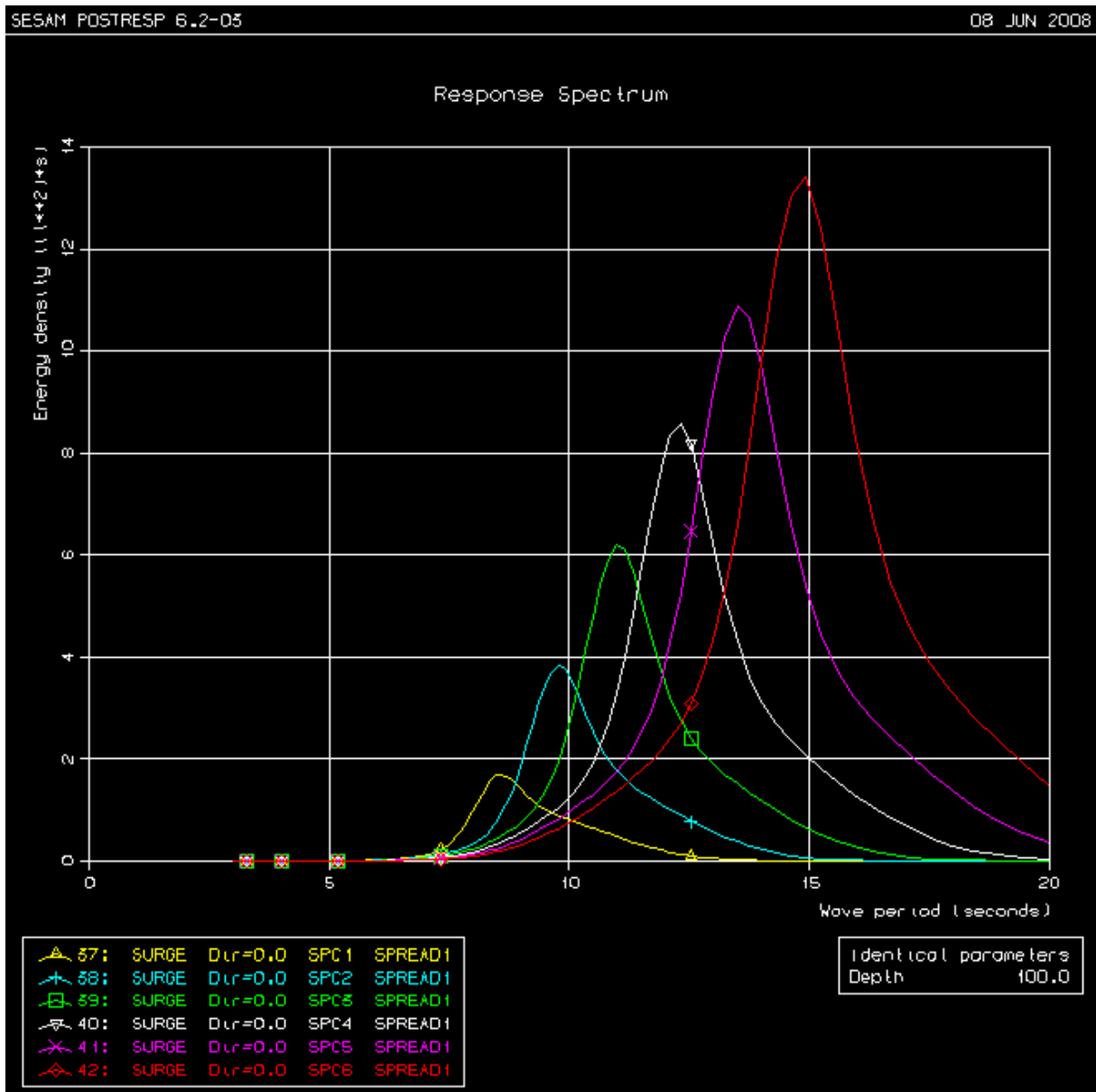

Figure 55: Response spectrum surge for $6,5 \text{ s} < T_z < 11,5 \text{ s}$, and $H_s=6,5\text{m}$

C4 Response spectra acceleration

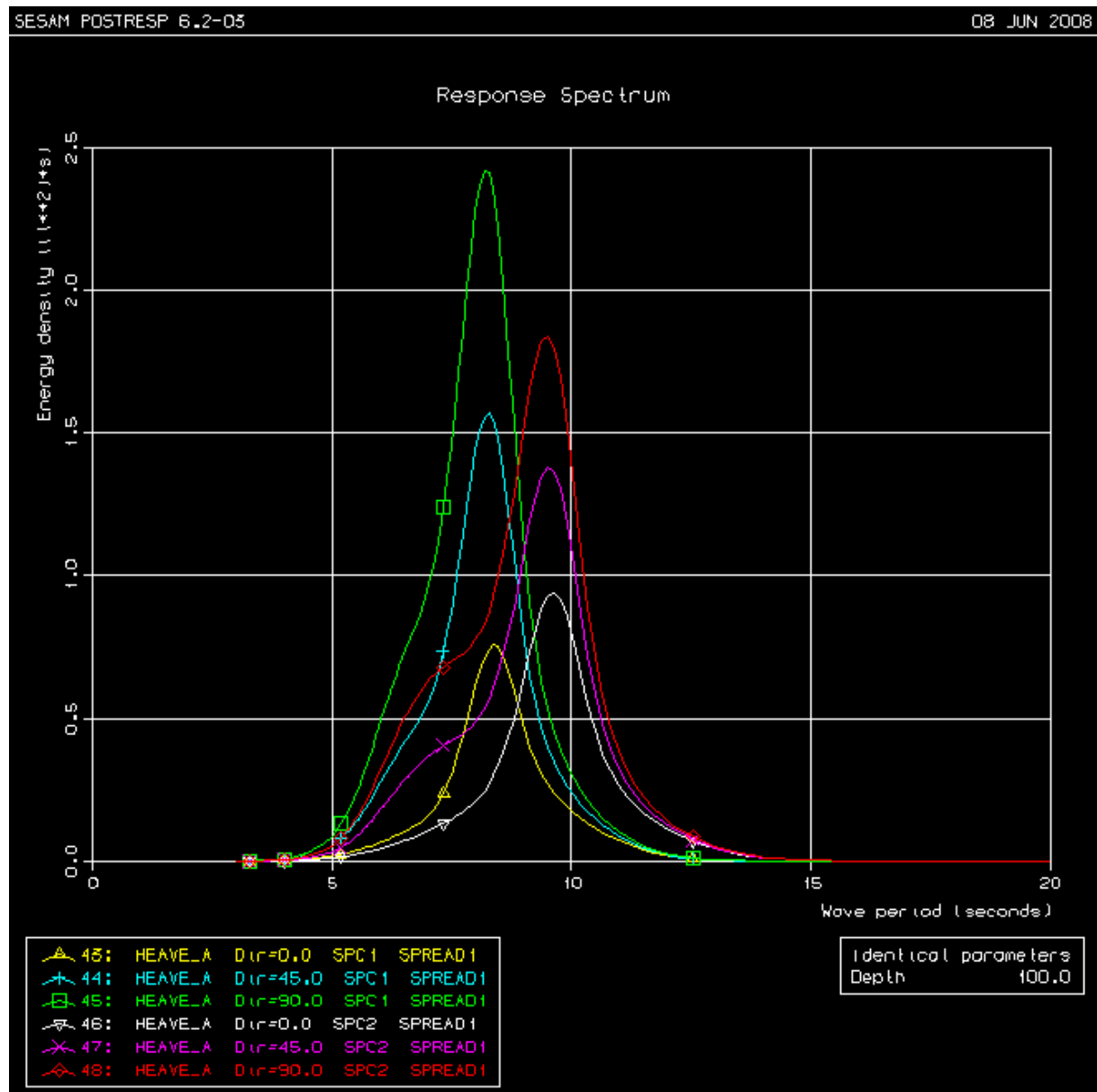

Figure 56: Response spectrum for acceleration in heave for $T_z=6,5$ s and $T_z=7,5$ s and $H_s=6,7$ m

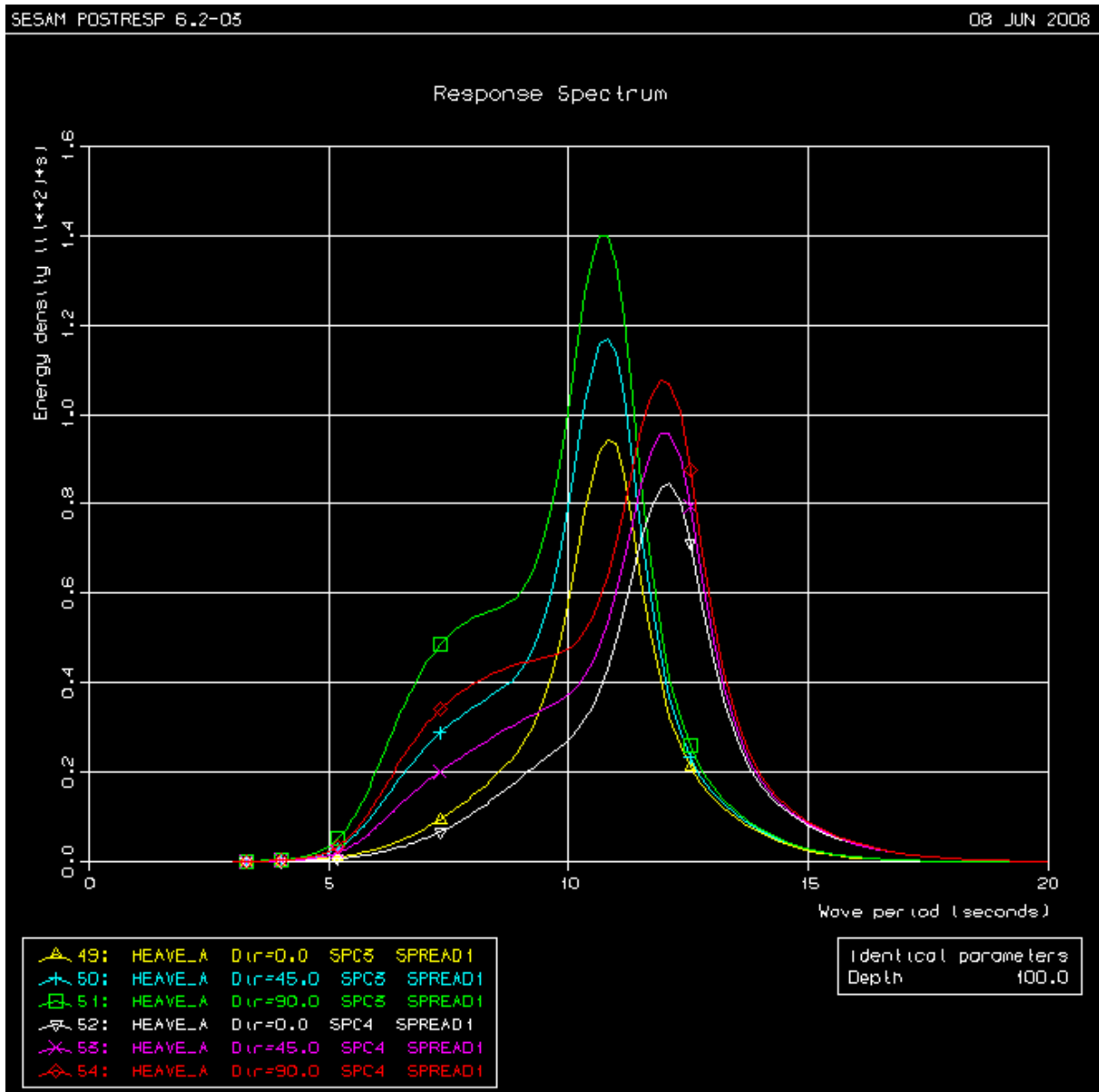

Figure 57: Response spectrum for acceleration in heave for $T_z=8,5$ s and $T_z=9,5$ s and $H_s=6,7$ m

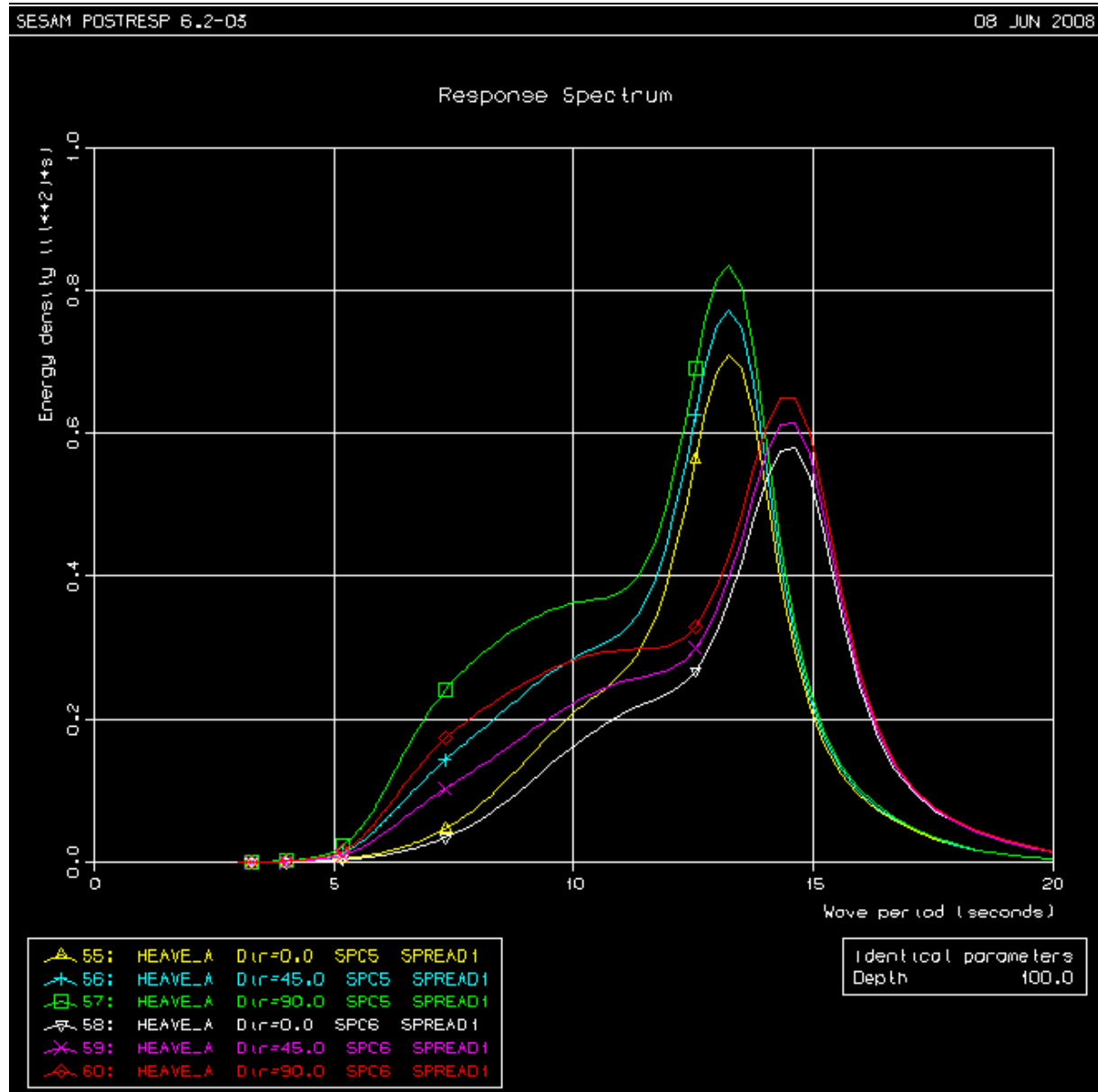

Figure 58: Response spectrum for acceleration in heave for $T_z=10,5$ s and $T_z=11,5$ s and $H_s=6,7$ m

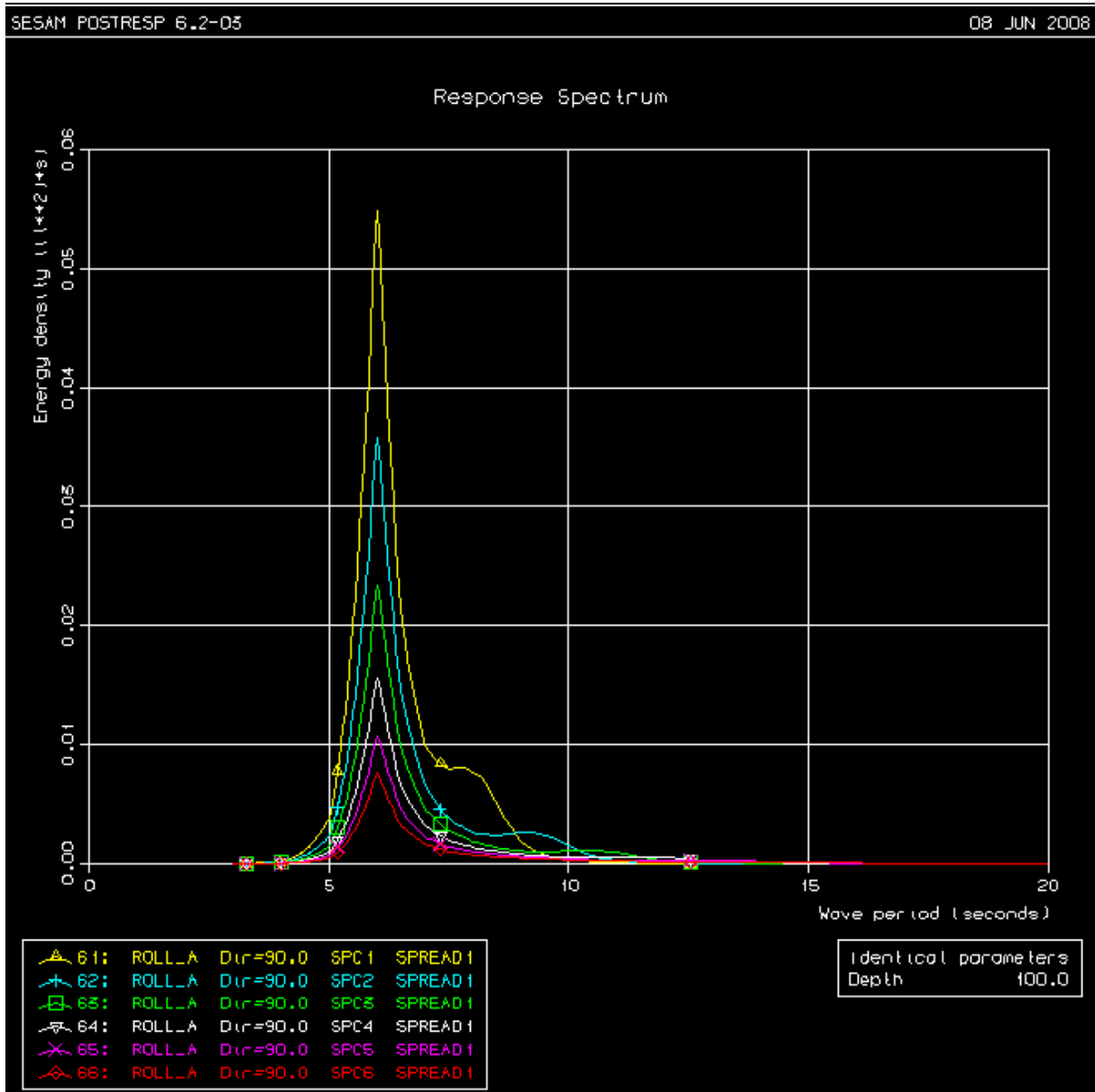

Figure 59: Response spectrum for acceleration in roll for $6,5 \text{ s} < T_z < 11,5 \text{ s}$ and $H_s=6,7\text{m}$

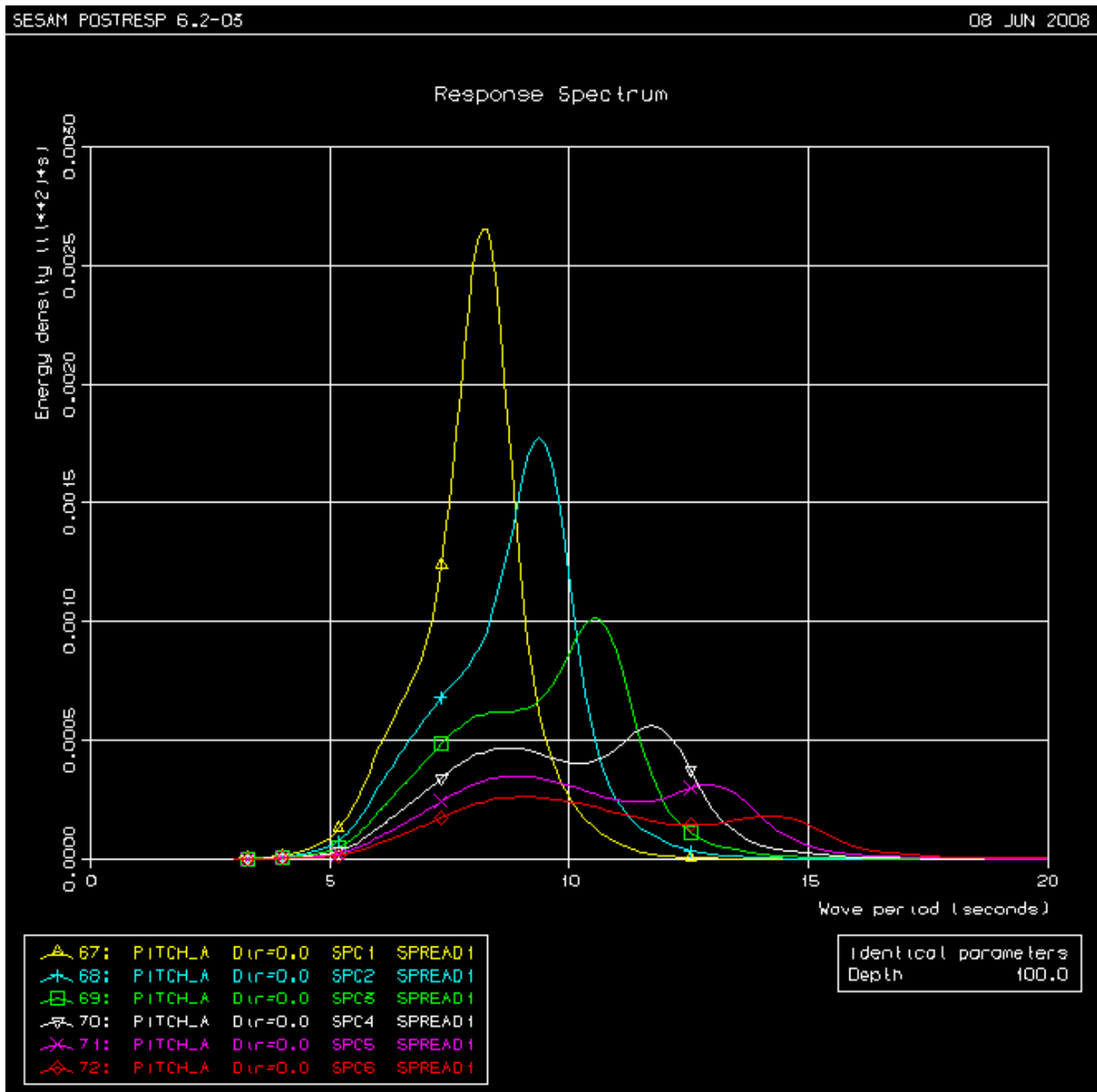

Figure 60: Response spectrum for acceleration in pitch for $6,5 \text{ s} < T_z < 11,5 \text{ s}$ and $H_s=6,7\text{m}$

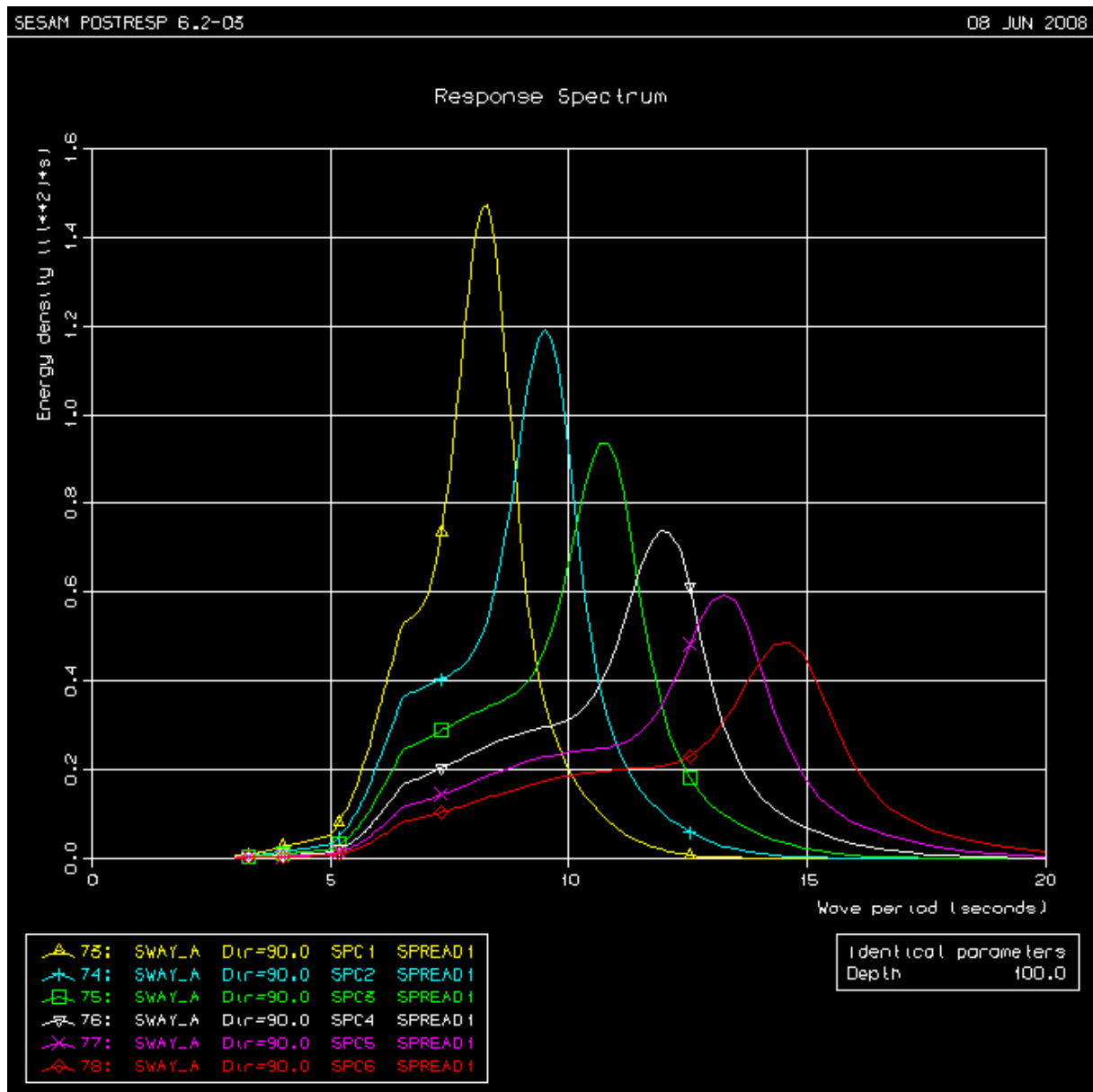

Figure 61: Response spectrum for acceleration in sway for $6,5 \text{ s} < T_z < 11,5 \text{ s}$ and $H_s=6,7\text{m}$

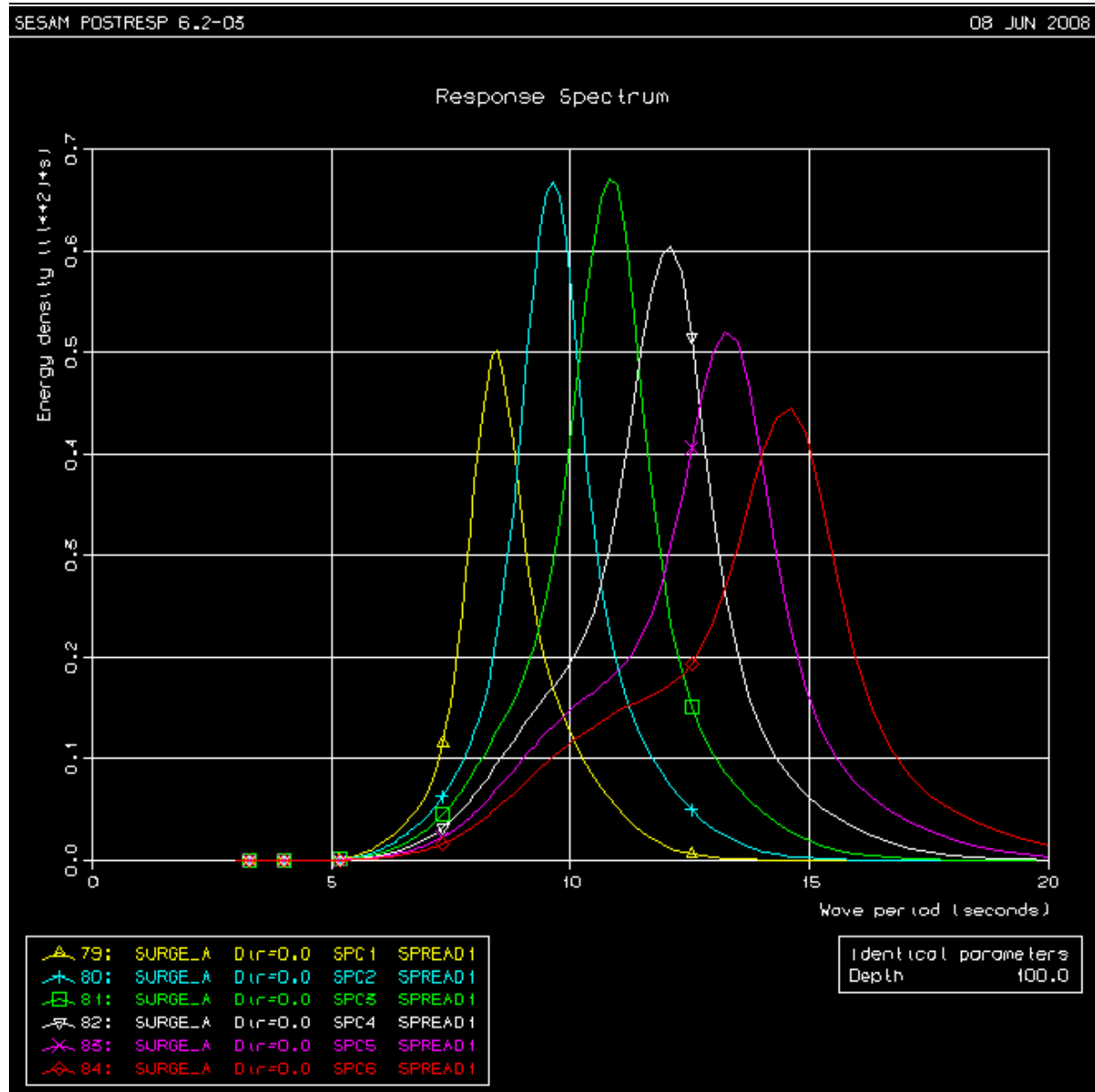

Figure 62: Response spectrum for acceleration in surge for $6,5 \text{ s} < T_z < 11,5 \text{ s}$ and $H_s=6,7\text{m}$

C5 Response spectrum for combined accelerations

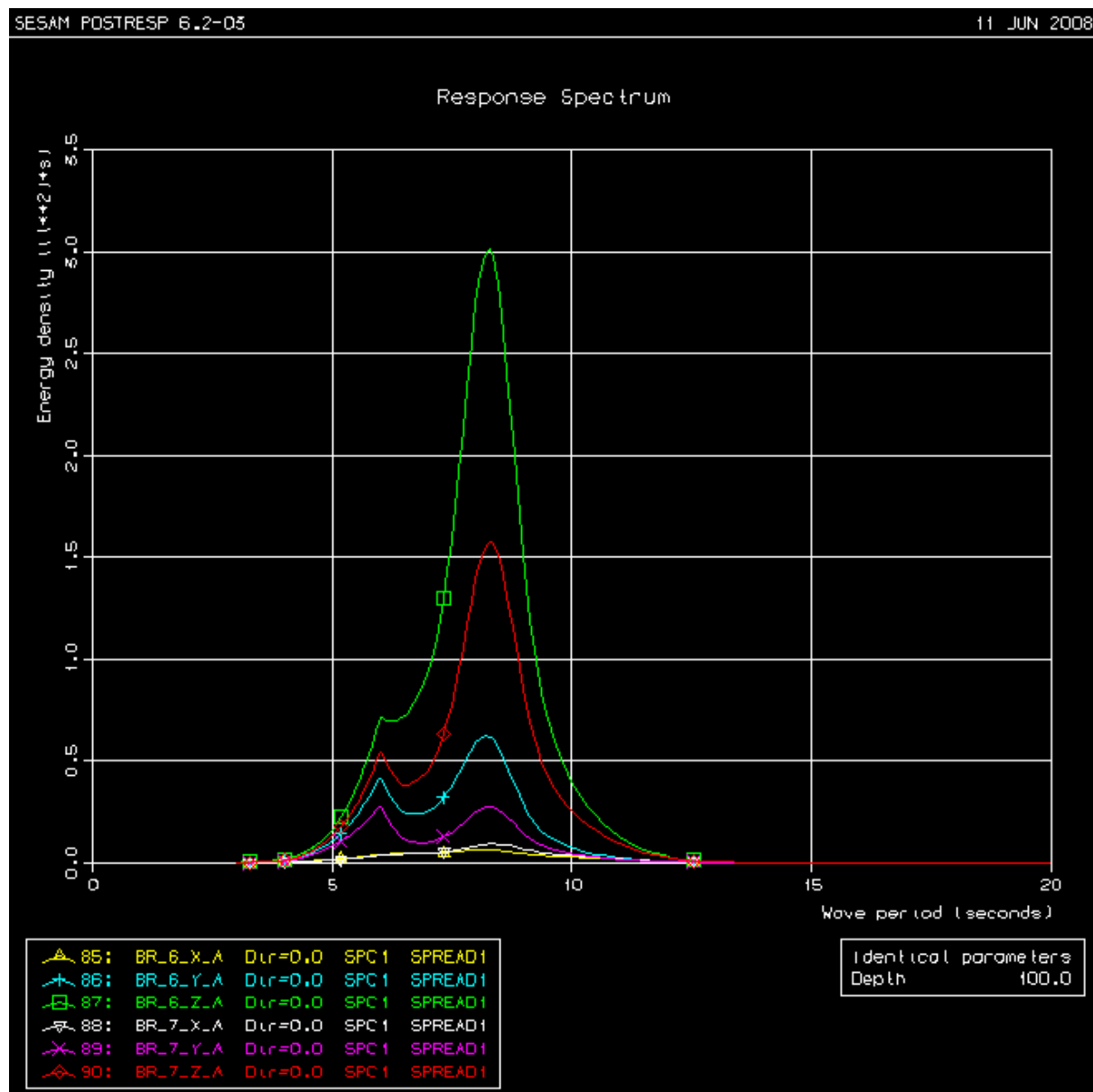

Figure 63: Response spectrum for accelerations in x, y and z-direction for Bridge 6 and 7, Hs=6,7 m and Tz=6,5s

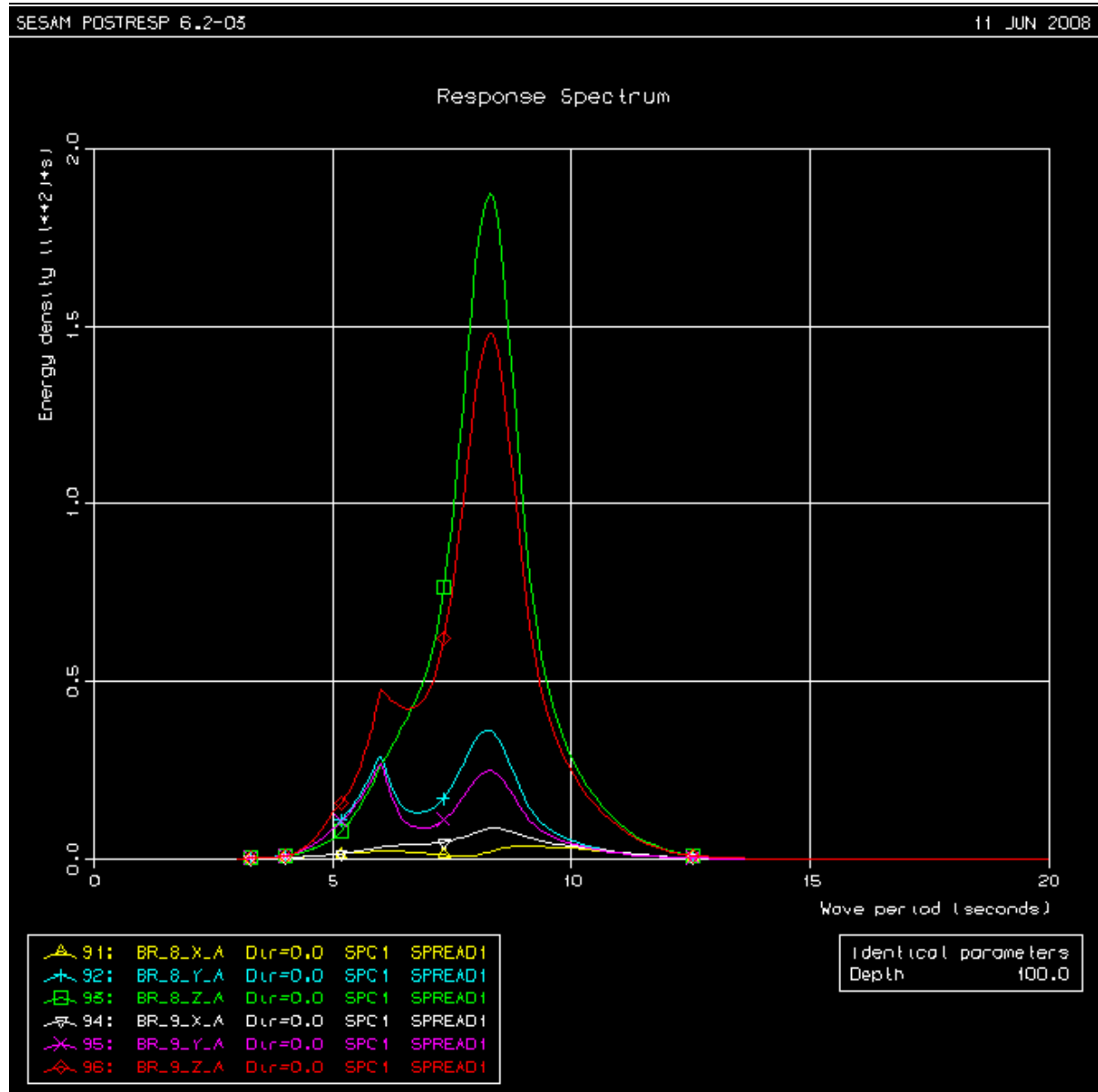

Figure 64: Response spectrum for accelerations in x, y and z-direction for Bridge 8 and 9, Hs=6,7 m and Tz=6,5s

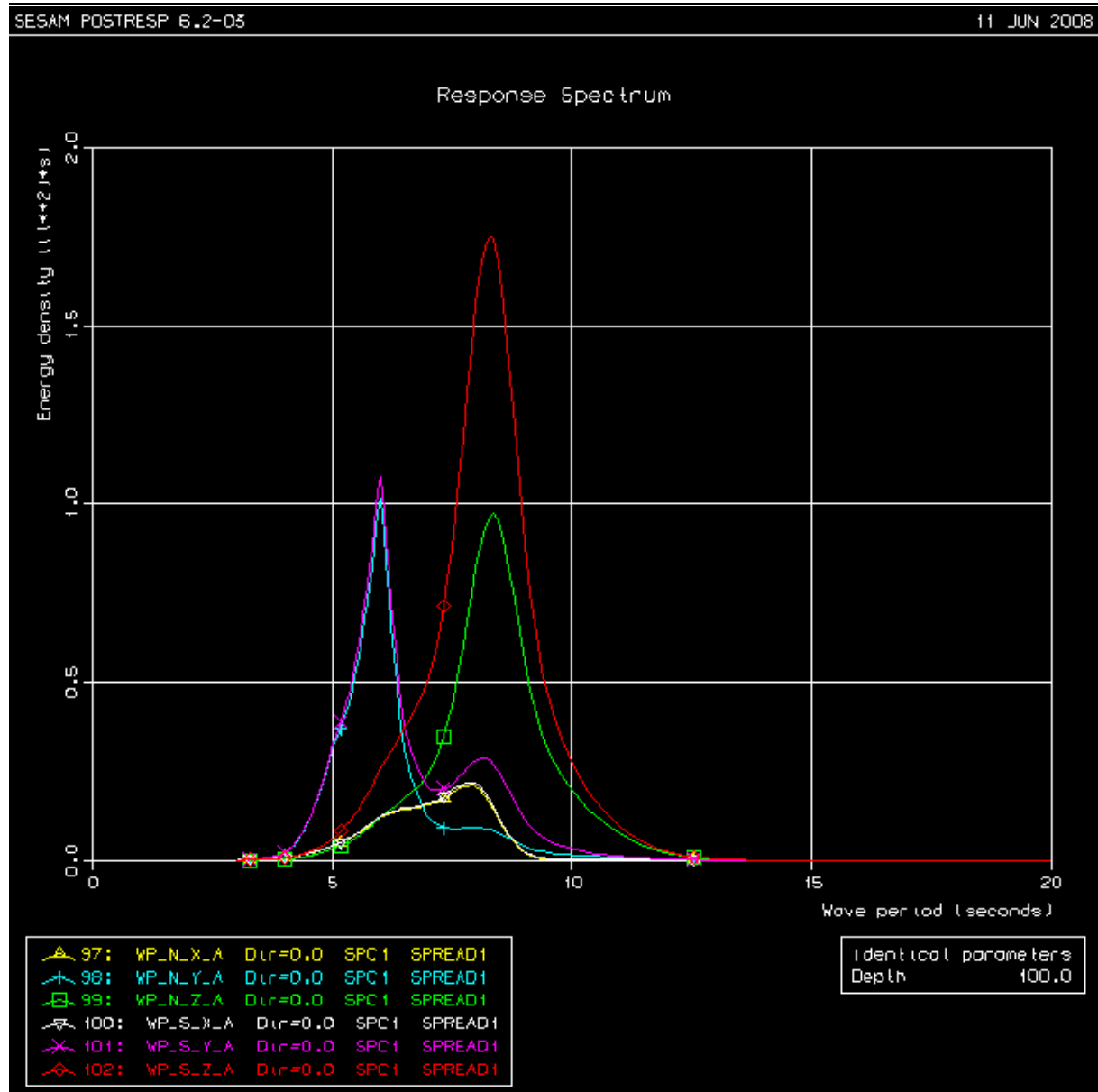

Figure 65: Response spectrum for accelerations in x, y and z-direction for WP Tower North and South, Hs=6,7 m and Tz=6,5s