



Faculty of Science and Technology

# MASTER'S THESIS

Study program/ Specialization:  Mechanical and Structural Engineering and Materials / Offshore Structural Engineering	Spring semester, 2013  Open / <del>Restricted access</del>
Writer: Andreas Askilrud Berntsen	.....  (Writer's signature)
Faculty supervisor: Professor Ove Tobias Gudmestad  External supervisor(s): Håkon Thingstad (Subsea 7)	
Title of thesis:  <i>An Evaluation and Estimation of Stresses on a Vessel's Side Plate and its Capacity</i>	
Credits (ECTS): 30	
Key words: Offshore, Vessel, Beam theory, Plate, STIPLA,	Pages: 85  + enclosure: 97 + CD  Stavanger, 27/06/2013 Date/year

**AN EVALUATION AND ESTIMATION OF STRESSES ON A VESSEL'S SIDE PLATE AND  
ITS CAPACITY**

by

ANDREAS ASKILSRUD BERNTSEN

Submitted to the Department of Mechanical and Structural Engineering and Materials  
Science in fulfillment of the requirements of the Master Degree program specialized  
in Offshore Structural Engineering

at the

University of Stavanger

June 2013

## ABSTRACT

History shows that the combination of stresses and pressure in a vessel can cause failure and lead to huge losses, examples of this are the ‘Prestige accident’ (November 2002) and the ‘Energy Concentration accident’ (July 1980). In the oil and gas industry structures are often mobilized on the deck of a vessel, transported to a specific location offshore and installed on the seabed. Occasionally these structures are quite large, resulting in their sticking out from the deck. A side plate in the sheer strake area needs to be evaluated, as stresses from the protruding structure, and stresses and pressure from the vessel’s global loads, gives in-plane stresses and out-of-plane pressure. In this study, the aim is to establish a simplified approach for estimating stresses that arise from a vessels global loads, evaluate how much these stresses might influence the plate capacity and conclude whether these stresses should be included in a plate capacity check in Subsea 7.

At this time, researchers such as Paik, Owen and Mansour are considered as well-established researchers in naval society, and their studies will be used to reach a method for finding the arising stresses on plate that occur because of the global vessel loads. The stresses will be estimated by idealizing the vessel as a hull girder and applying beam theory combined with recommendations from Det Norske Veritas. The study shows that there are several key factors to establish these stresses and these factors will be estimated numerically and by computer software.

The study shows that a stiffened side plate that is subjected to in-plane and out-of-plane stresses and pressure can experience failure modes when the structure on deck results in large stresses. In this study a stiffened plate capacity checks will be evaluated based on Det Norske Veritas (DNV) and NORSOK standards and recommended practices, and are considered as state-of-the-art approaches.

The study concludes that both the magnitude of the global stresses and the stiffened plate’s characteristics are key factors in determining how much the global stresses influence the capacity of a specified plate.

## ACKNOWLEDGMENTS

I would like to express my deepest gratitude to my professor and supervisor, Ove Tobias Gudmestad for his high level of dedication and support over the courses at the University and throughout the entire process of the master thesis. His distinct insight in the oil and gas industry is greatly appreciated.

Structural discipline manager at the Forus office, Håkon Thingstad, has been very helpful throughout the whole process of thesis. I would like to voice my appreciation and thank him for proposing the thesis topic and for his continual guidance, discussions and his assistance.

I would also like to thank Professor Jonas Odland at the University of Stavanger for taking time to meet me and discuss my thesis. The meeting gave increased perspective regarding the thesis.

Throughout the process, several of my future colleagues in Subsea 7 have given support. I would like to address special thanks to Prashant Harischandra in the structure department, and Petter Moen and Monobrata Saha in the naval department for their guidance concerning the thesis study.

Last but not least, I would like to express my gratitude to the Captain and the First Officer of the *Seven Seas*, who provided me with longitudinal stability results for the *Seven Seas*.

# TABLE OF CONTENTS

<b>ABSTRACT</b> .....	<b>iii</b>
<b>ACKNOWLEDGMENTS</b> .....	<b>iv</b>
<b>LIST OF FIGURES</b> .....	<b>vii</b>
<b>LIST OF TABLES</b> .....	<b>ix</b>
<b>NOMENCLATURE</b> .....	<b>xi</b>
<b>1 INTRODUCTION</b> .....	<b>1</b>
1.1 BACKGROUND .....	1
1.2 OBJECTIVE .....	2
1.3 CONTENT .....	3
1.4 COMPUTER PROGRAMS USED .....	3
<b>2 BACKGROUND THEORY</b> .....	<b>4</b>
2.1 WEATHER AND WAVE CONDITIONS .....	4
2.2 A VESSEL'S OVERVIEW .....	4
2.2.1 Loading Conditions .....	4
2.2.2 Hull Strength and Arrangements.....	7
2.2.3 Structural Vessel Responses.....	11
2.3 BASIS OF GLOBAL STRUCTURAL LOADS .....	12
2.3.1 Main Description and Classification of Loads.....	12
2.3.2 Bending Moments and Shear Forces along the Vessel .....	14
2.3.3 Torsion Influence .....	17
2.3.4 Sea and Ballast Pressure.....	18
2.4 THE SIDE PLATE .....	19
2.4.1 Side Plate Arrangement.....	19
2.4.2 Stiffened Plate Failures .....	20
<b>3 ESTABLISHMENT OF STRESSES AND PRESSURE ON THE PLATE</b> .....	<b>22</b>
3.1 APPROACH METHODS .....	22
3.2 SELECTED APPROACH METHOD .....	23
3.2.1 General Guidance .....	23
3.2.2 Establish Bending Moments and Shear Forces along Vessel .....	24
3.2.3 Establish Neutral Axis and Moment of Inertia.....	30
3.2.4 Establish Stresses on Side Plate .....	31
3.2.5 Establish Sea Pressure .....	36
3.3 RESULTS: AN ESTIMATION OF STRESSES ON PLATE.....	38
3.3.1 Design Basis .....	38
3.3.2 Bending Moments and Shear Forces.....	41
3.3.3 Neutral Axis and Moment of Inertia .....	42
3.3.4 Stresses on the Plate .....	44
3.4 RESULTS: AN ESTIMATION OF SEA PRESSURE .....	46
3.5 SUMMARY .....	47

<b>4</b>	<b>AN EVALUATION OF THE PLATE CAPACITY.....</b>	<b>49</b>
4.1	THE APPROACH METHOD .....	49
4.2	RESULTS: AN EVALUATION OF THE PLATE CAPACITY .....	50
4.2.1	Design Basis .....	50
4.2.2	STIPLA Software Application .....	51
4.2.3	Design Case 1 .....	52
4.2.4	Design Case 2.....	55
4.3	SUMMARY .....	61
<b>5</b>	<b>DISCUSSION .....</b>	<b>63</b>
5.1	THE ESTIMATION OF STRESSES .....	63
5.2	THE EVALUATION OF PLATE CAPACITY .....	64
5.3	THE INFLUENCE OF GLOBAL STRESSES ON THE EVALUATED SIDE PLATE .....	65
<b>6</b>	<b>CONCLUSION.....</b>	<b>66</b>
<b>7</b>	<b>FURTHER STUDIES .....</b>	<b>69</b>
<b>8</b>	<b>REFERENCES .....</b>	<b>70</b>
	 <b>LIST OF APPENDICES .....</b>	 <b>72</b>
	APPENDIX A - Longitudinal design bending moments and design shear forces	
	APPENDIX B - Strength diagrams, <i>Seven Seas</i> stability booklet	
	APPENDIX C - Longitudinal strength diagram retrieved from the <i>Seven Seas</i>	
	APPENDIX D - Neutral axis and moment of inertia for webframe	
	APPENDIX E - Stresses on side plate	
	APPENDIX F - Sea pressure on plate	
	APPENDIX G – Plate capacity check	
	APPENDIX H - Holland Profile table	
	APPENDIX J - Drawings of the <i>Seven Seas</i>	

## LIST OF FIGURES

Figure 1-1: Outer side plate of concern in the case where a structure is sticking out from the deck. ....	1
Figure 2-1: Longitudinal strength diagram for <i>Seven Seas NAPA software</i> . ....	5
Figure 2-2: A basic overview of terms used for locations at a vessel. ....	7
Figure 2-3: Presenting a section of a hull with longitudinal framing system. ....	8
Figure 2-4: Primary, secondary and tertiary response structure. ....	11
Figure 2-5: Buoyancy pressure and weight distribution of a simplified vessel. ....	14
Figure 2-6: Longitudinal distribution loads on a bulk carrier. ....	15
Figure 2-7: Hogging and sagging conditions. ....	16
Figure 2-8: Torsion when waves are coming in from starboard at an angle. ....	17
Figure 2-9: Sea pressure acting on a hull in wave. ....	18
Figure 2-10: An illustration of the side plate at sheer strake area. ....	19
Figure 2-11: Longitudinal stiffened plate relevant stresses and pressure. ....	20
Figure 3-1: Bending moment ( $M_s$ ) and shear forces ( $Q_s$ ) sign conventions. ....	25
Figure 3-2: Still water bending moment distribution and variance. ....	26
Figure 3-3: Wave bending moment distribution and variance. ....	27
Figure 3-4: Wave shear force distribution and variance. ....	29
Figure 3-5: Bending stress across a multi-cell section under hogging condition. ....	32
Figure 3-6: Shear flow for a vessels multi-cell section. ....	34
Figure 3-7: <i>Seven Seas</i> from starboard side view. ....	38
Figure 3-8: <i>Seven Seas</i> main deck (deck 4) arrangement. ....	38
Figure 3-9: Webframe 72 in <i>Seven Seas</i> . ....	39
Figure 3-10: Webframe 72 and arrangement of the stiffened plate. ....	40
Figure 3-11: Estimated vertical distance ( $Z_{NA}$ ) for the webframe. ....	42
Figure 3-12: Estimated half of the moment of inertia for the webframe. ....	43
Figure 3-13: Sea pressure on <i>Seven Seas</i> side. ....	46
Figure 3-14: Variation in stresses during <i>Seven Seas</i> fuel change. ....	47
Figure 4-1: Longitudinal stiffened plate and its load combinations. ....	50
Figure 4-2: Design case 1; buckling and yield capacity curve for stiffener. ....	52
Figure 4-3: Plate geometry and the allowable vertical stress on stiffened plate. ....	53
Figure 4-4: 70% allowable in-plane vertical stress on stiffened plate. ....	54

Figure 4-5: Stresses and stiffened plate arrangement for case 2.1 .....55

Figure 4-6: Design case 2.1; Buckling and yield capacity curve for stiffener and plate. ....56

Figure 4-7: Stresses and stiffened plate arrangement for case 2.2.....57

Figure 4-8: Design case 2.2; Buckling and yield capacity curve for stiffener and plate. ....58

Figure 4-9: Stresses and stiffened plate arrangement for NAPA load case. ....59

Figure 4-10: Design case 2.3; Buckling and yield capacity curve for stiffener and plate. ....60

Figure 6-1: The main steps for determine the stresses arising from a vessels global loads .....66



## LIST OF TABLES

Table 2-1: Light ship (for information only) .....	6
Table 2-2: Sailing condition - loaded for flex lay, no deck carousel (all fuel 100%)....	6
Table 2-3: Sailing condition - loaded for flex lay, no deck carousel (IFO 50%, MGO 50%).....	6
Table 2-4: Specifying the numbers in Figure 2-3. ....	8
Table 3-1: Adjustment to $k_{wm}$ when vessel is at high speed. ....	27
Table 3-2: Adjusting $k_{wq}$ for vertical shear forces. ....	28
Table 3-3: General <i>Seven Seas</i> characteristics.....	38
Table 3-4: Bending moments and shear forces at 72m from AP.....	41
Table 3-5: Bending moments and shear forces at 72m from AP.....	41
Table 3-6: Bending moments and shear forces at 72m from AP.....	41
Table 3-7: Comparing the estimated $Z_{NA}$ and $I_y$ . ....	43
Table 3-8: Estimated design stresses at point A and C, DNV approach.....	44
Table 3-9: Estimated stresses at point A and C, Stability Booklet approach. ....	44
Table 3-10: Estimated stresses at point A and C, NAPA approach.....	44
Table 3-11: Estimated design stresses at point B and D, DNV approach.....	45
Table 3-12: Estimated stresses at point B and D, Stability Booklet approach. ....	45
Table 3-13: Estimated stresses at point B and D, NAPA approach.....	45
Table 3-14: Estimated sea pressure acting on the <i>Seven Seas</i> side shell. ....	46
Table 4-1: Geometrical data for the side plate.....	50
Table 4-2: Plate capacity results, design case 1; -203MPa allowable stress. ....	53
Table 4-3: Plate capacity results, design case 1; 70% allowable stress. ....	54
Table 4-4: Plate capacity results, design case 2.1 .....	56
Table 4-5: Plate capacity results, design case 2.2.....	58
Table 4-6: Results design case 2.3, from NAPA .....	60
Table 6-1: Stresses at the upmost point on plate due to <i>Seven Seas</i> loading condition: still-water light ship condition with 400 tons at aft and 200 tons structure above the plate on main deck. ....	67

Table 6-2: Stresses at the upmost point on plate due to *Seven Seas* loading condition: DNV design rule bending moment and shear force distribution under sagging condition. ....67

Table 6-3: The influence of global vessel loads on a specific side plate at sheer strake under *Seven Seas* still-water light ship condition with a 400 tons structure on deck and a 200 tons structure above the plate on main deck. Design sea pressure also included.....68

Table 6-4: The influence of global vessel loads on a specific plate at sheer strake under *Seven Seas* design rule bending moment, shear force and sea pressure. ....68

## NOMENCLATURE

### Terms

$10^{-4}$ Probability of exceedance	Approximate daily return period
$10^{-8}$ Probability of exceedance	Approximate 20-year return period
Block coefficient	Ratio between the actual submerged volume of a vessel and the box volume around the submerged part of the vessel.
Green water	Water on deck
Hogging	Vessel bending upwards amidships
Sagging	Vessel bending downwards amidships
x-direction	Longitudinal direction
y-direction	Transverse direction
z-direction	Vertical direction

### Abbreviations

Aft.	The portion of the vessel behind the middle area of the vessel, towards stern
AP	The after perpendicular
BM	Bending moment
CL	Centerline
DNV	Det Norske Veritas
FEA	Finite element analysis
FEM	Finite element modeling
FP	The forward perpendicular

HP	Holland profile
IACS	The International Association of Classification Societies
IFO	Intermediate fuel oil
LRFD	Load and Resistance Factor Design
MGO	Marine gas oil
NA	Neutral axis
SF	Shear force
SM	Section Modulus
SS7	Subsea 7

## Symbols

### Latin Characters

A	Area
$A_i$	Area of element
$A_{DK}$	Projected area in the horizontal plane of upper deck forward of 0.2 L from FP
$A_{WP}$	Area of water plane forward of 0.2 L from F.P. at draught T
B	Greatest molded breadth
$b_i$	Horizontal breadth of element
$C_B$	Block coefficient
$C_W$	Wave coefficient
D	Molded depth
$d_i$	Vertical distance from NA of webframe to center of gravity of element
E	Modulus of elasticity

$f$	Vertical distance from the waterline to the top of the ship's side at transverse section considered
$h_0$	Vertical distance from the waterline at draught T to the load point
$h_i$	Vertical height of element
$H_s$	Significant wave height
$I$	Second moment of inertia around a given axis
$I_i$	Second moment of inertia around a given axis for an element
$I_{req}$	Required second moment of inertia in accordance with DNV
$L$	Stiffener span
$L_g$	Length of girder
$L_p$	Length between perpendiculars
$L_t$	Lateral torsional buckling
$M$	Bending moment
$M_D$	Design bending moment
$M_{hog}$	Bending moment under hogging condition
$M_S$	Design still-water bending moment
$M_{sag}$	Bending moment under sagging condition
$M_W$	Wave bending moment
$p_{sd}$	Sea pressure
$q$	First moment of area around a given axis
$Q$	Vertical shear force in the transverse section
$Q_S$	Design still-water shear force
$Q_W$	Wave shear force
$R_d$	Design resistance
$s$	Spacing between stiffeners
$S_d$	Design load effect

$t$	Width of the section at the elevation considered
$t_{ave}$	Thickness of webframe at sheer strake area, in accordance with DNV
$T_{mean}$	Mean molded summer draught in m
$V$	Maximum service speed in knots
$y_1$	Horizontal distance from the centerline to the load point
$z_0$	Required midship section modulus in accordance with DNV
$z_1$	Vertical distance from the baseline to the load point
$Z_A$	Vertical distance from neutral axis to point A at plate
$Z_B$	Vertical distance from neutral axis to point B at plate
$Z_i$	Vertical distance from baseline to center of gravity for element
$z_f$	Vertical distance from summer load waterline to deck line measured at FP
$Z_{NA}$	Vertical distance from baseline to the neutral axis

### Greek Characters

$\alpha_{seag}$	Factor under seagoing condition used in DNV equation
$\alpha_{shelt}$	Factor under sheltered condition used in DNV equation
$\beta_{seag}$	Factor under seagoing condition used in DNV equation
$\beta_{shelt}$	Factor under sheltered condition used in DNV equation
$\sigma_{jd}$	The von Mises equivalent design stress
$\sigma_z$	In-plane vertical stress
$\sigma_x$	In-plane longitudinal stress
$\tau_{ave}$	Average shearing stress

# 1 INTRODUCTION

## 1.1 BACKGROUND

Subsea 7 is a worldwide seabed-to-surface engineering, construction and service contractor to the offshore energy industry. Mobilizing large structures on the deck of a vessel, transporting these structures to a specific location offshore and installing them on the seabed are activities frequently carried out by service contractors.

A structure that is mobilized and sea-fastened on deck may come in numerous variant sizes and shapes, for example as a spool, a manifold or as other alternative structures. Occasionally these structures are quite large, resulting in their sticking out from the deck. Therefore extra stresses on the stiffened side plate (shell) around the sheer strake area occur. The protruding structure on deck may weigh up to several hundred tons, and the following stresses on the side plate will influence the stiffened plate capacity. Not only stresses from the protruding structure influence the plate capacity, but also stresses which arise from a vessel's global loads. The question is: to what extent do these 'global' vessel loads influence the plate's capacity while a structure is sticking out from deck?

Figure 1-1 shows a typical location of a stiffened side plate (shell) of concern with an illustrated structure on deck.

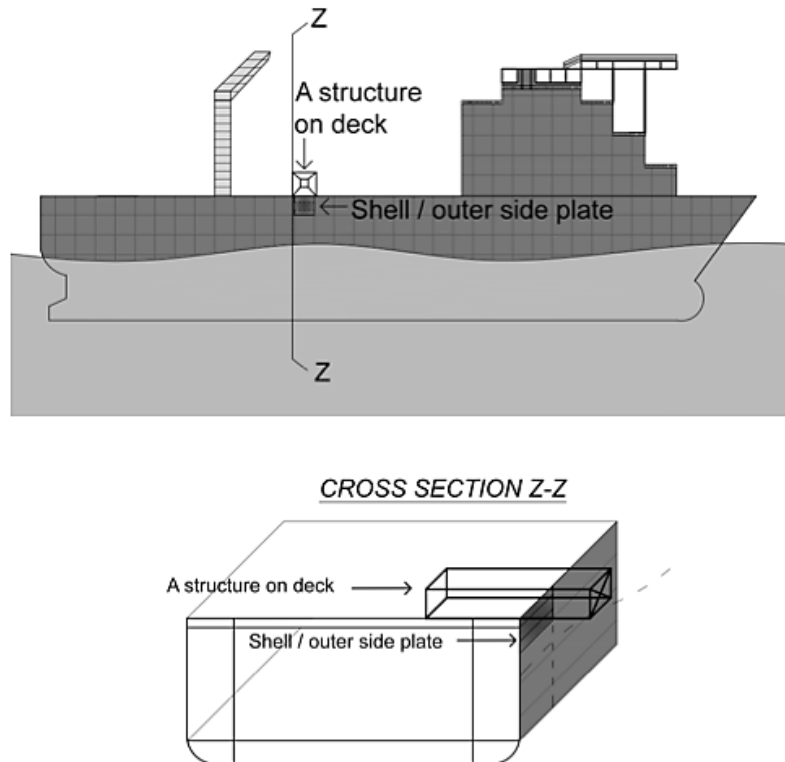

Figure 1-1: Outer side plate of concern in the case where a structure is sticking out from the deck.  
*Designed in AutoCAD*

An evaluation of the ‘global’ stresses on a plate should be performed to ensure that no failure modes on the sheer strake area are imminent. It is important to evaluate the stresses arising on a plate and thereafter perform a capacity check of the plate to ensure that it does not yield or buckle. Until now, Subsea 7 has not experienced any failures in a vessel’s side plate, but, if a failure was to occur, the consequences will lead to huge losses. As the oil and gas industry continues to undertake challenging projects by going into deeper waters and mobilizing larger components at the seabed, it is obvious that larger structures on a vessel deck will follow.

Stresses from ‘global’ vessel loads on a side plate are not included in a plate capacity check in Subsea 7. This thesis will consider the global vessel loads and establish a procedure for finding the stresses that are acting on the plate. This thesis will evaluate a side plate capacity mainly with respect to local buckling, global buckling and yielding when the plate is subjected to separate and combined ‘global’ and ‘local’ stresses. In this study the term ‘local’ loads/stresses is defined as the load and stresses arising due to the structure on deck. The term ‘global’ loads and stresses are defined as the primary loads and stresses for a vessel.

## **1.2 OBJECTIVE**

The objectives of this thesis are to:

- Get an overall understanding of the global vessel loads that affect the plate
- Find an approach to estimate the stresses on the plate resulting from the global vessel loads
- Implement the selected approach
- Evaluate a plate capacity for both ‘local’ and ‘global’ stresses
- Compare ‘global’ stresses versus ‘local’ stresses on the plate. Compare how vessel loading conditions contribute to the stresses on a plate.



### 1.3 CONTENT

Chapter 2 presents the background theory before the approach for finding global stresses starts. The chapter begins by briefly introducing weather and wave conditions. It describes a vessel's loading conditions, a hull's strength and the elements contributing to its longitudinal strength. A definition of structural vessel responses is also included. The chapter describes loads acting on a vessel and discusses a vessel's bending moments, shear forces, torsion and sea pressure. The chapter also presents background theory on stiffened plate failures and background theory related to buckling and yielding.

Chapter 3's objectives are to establish a procedure to find the 'global' stresses and pressure on plate. After establishing the procedures, the thesis will perform these and estimate the 'global' stresses and pressure on an assumed plate for the vessel, *Seven Seas*. Stresses on the *Seven Seas* side plate will be evaluated with respect to IACS' classification rules, different loading conditions which are presented by the shipyard company IHC Merwede and NAPA software onboard the *Seven Seas*.

Chapter 4 uses the stresses and pressure obtained in Chapter 3 and evaluates the plate capacity. The computer software STIPLA is used to evaluate the capacity checks.

Finally, discussion, further studies and an overall conclusion are presented.

### 1.4 COMPUTER PROGRAMS USED

Software programs used in the writing of this thesis are:

- Mathcad                    - Estimate bending moments and shear forces over vessel's length  
                                  - Calculate moment of inertia and neutral axis of a given webframe  
                                  - Calculate stresses and sea pressure on the plate
- AutoCAD                    -Create sketches and figures  
                                  -Estimate neutral axis and moment of inertia for selected webframe
- Microsoft Excel        Create tables and diagrams
- Section                    Attempted to model a *Seven Seas* webframe and then obtain its moment of inertia and its neutral axis.  
                                  Conclusion: webframe is too massive to run in Section.
- STIPLA                    Evaluate the plate capacity

## **2 BACKGROUND THEORY**

### **2.1 WEATHER AND WAVE CONDITIONS**

Weather and wave conditions influence a vessel's motions and generate stresses on a vessel's hull. A vessel's movement due to waves, wind and current causes stresses, stresses which come from dynamic loads and sea pressure. In this chapter (Chapter 2) the thesis will introduce basic knowledge of the wave loads that are working on a hull.

Before a vessel leaves harbor, wave spectra and a three-day weather forecast must be presented [1]. A high probability of reaching an acceptable weather window is required before a vessel may leave harbor and perform an operation. 'Acceptable weather window' means that the installation procedure needs to be within required weather and sea states, such as for example satisfying wave height, length and period.

### **2.2 A VESSEL'S OVERVIEW**

#### **2.2.1 Loading Conditions**

A vessel's loading condition greatly influences the hull's capacity. The loading condition is determined by the condition of ballast, fuel, equipment on board, the crew on board etc. A light ship condition, for example, means that there is no ballast, fuel or extra equipment on board. All of these different loading conditions give a different distribution of bending moment and shear forces over a vessel's hull.

Normally a supply vessel has an integrated loading condition system onboard, which evaluates the hull's capacity with respect to how a vessel is loaded. When the vessel's officer has entered the weight of all items on the ship into the loading program, the computer can calculate the vessel's longitudinal and transverse stability, including the vessel's shearing forces and bending moments. Some of the components that the system takes into account are structures on deck, ballast, fuel, weight of equipment, weight of machinery, and weight of hull and all other components which contribute to the weight/buoyancy distribution. The program compares the loaded situation with the requirements and regulations from the classification bureau and the proper authorities. So basically, if the present loading condition of a vessel rises above the designed hull capacity, the loading condition system should point out that the hull is overloaded or stability criteria are not met.

Appendix C presents a longitudinal strength diagram obtained from the *Seven Seas* integrated loading condition called NAPA. This loading case is obtained by request from the author to the Captain and does not represent an actual operation condition. The loading case evaluated in NAPA is a light ship condition with a 400-ton deck load at aft and a 200-ton structure on deck around amidships (webframe 72). By comparing this loading case with the normal light ship condition (Appendix B), it can clearly be seen that the two deck loads influence the distribution of bending moment and shear forces over *Seven Seas*. The longitudinal strength diagram for the loading

case is presented in Figure 2-1. If we compare the normal light ship condition with the loading condition in NAPA, the NAPA loading case is considered to give additional bending and shear stresses for the side plate at webframe 72. The 400-ton deck load at aft will create extra bending moment around amidships. Additionally, the 200-ton structure on deck causes extra global shear forces and local vertical compressive stresses on the plate.

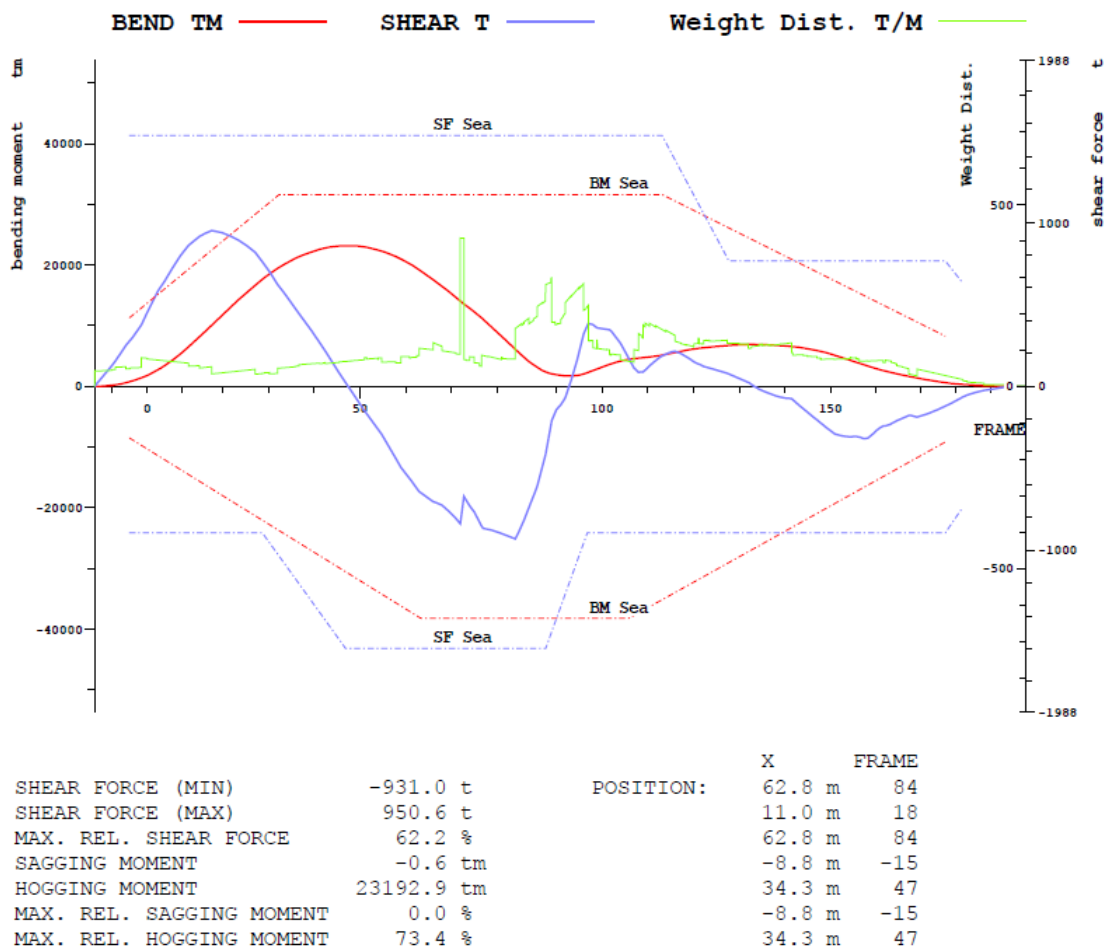

Figure 2-1: Longitudinal strength diagram for *Seven Seas* NAPA software.

Several different loading conditions are taken from the *Seven Seas* Stability Booklet, which is presented by the shipyard company IHC Merwede and approved by Lloyd's Register. The strength diagrams that are displayed in Appendix B clearly show significant changes in bending moment and shear force distribution over the *Seven Seas*' length in different loading conditions.

Three loading conditions are selected from the Appendix B and present a brief condition summary.

The first condition is a light ship condition and represents the lightest condition of the vessel and is not considered as an operating condition (No ballast, no fuel, no crew and no equipment on deck) [2]; see Table 2-1.

Table 2-1: Light ship (for information only)  
Taken from [2], condition 1.

<b>Deadweight</b>	1919.50 tons	<b>GMt fluid</b>	4.544 m
<b>Draft mean (molded)</b>	4.39 m	<b>KGt fluid</b>	13.77 m
<b>Max % Shear force (SF)</b>	-56.58 % <sup>1)2)</sup>	<b>Max % bending moment (BM)</b>	48.95 % <sup>3)</sup>

- 1) Meaning of negative value is explained in Section 3.2
- 2) Percentage of permissible SF
- 3) Percentage of permissible BM

The second and third conditions are at sailing conditions, they are loaded for flex lay with no carousel on deck, but with the J-Lay loader on deck. The second condition is fully fueled, while the third condition has only 50% fuel remaining. See Table 2-2 and Table 2-3 for some brief condition summaries.

Table 2-2: Sailing condition - loaded for flex lay, no deck carousel (all fuel 100%)  
Taken from [2], condition 4.

<b>Deadweight</b>	12674.53 tons	<b>GMt fluid</b>	2.587 m
<b>Draft mean (molded)</b>	7.33 m	<b>KGt fluid</b>	11.644 m
<b>Max % Shear force (SF)</b>	81.74%	<b>Max % bending moment (BM)</b>	42.54%

Table 2-3: Sailing condition - loaded for flex lay, no deck carousel (IFO 50%, MGO 50%)  
Taken from [2], condition 7.

<b>Deadweight</b>	9034.62 tons	<b>GMt fluid</b>	2.524 m
<b>Draft mean (molded)</b>	6.349 m	<b>KGt fluid</b>	12.585 m
<b>Max % Shear force (SF)</b>	51.86%	<b>Max % bending moment (BM)</b>	55.74%

A light ship condition is a theoretical condition. The condition does not represent an operational condition, but because there is no ballast or fuel, it may theoretically give significant stresses at a side plate amidships at the sheer strake area.

## 2.2.2 Hull Strength and Arrangements

As the author has neither a background in naval architecture nor any knowledge concerning a vessel's hull prior to this master's thesis, Section 2.1.2 is included for understanding and to illustrate the components of a hull. Through this, any reader with a background similar to the author's will gain general knowledge and recognize the upcoming mentioned parts or sections of a hull. The author has taken a great deal of time to study a typical hull arrangement and to grasp the important functions of some parts of the hull. Figure 2-2 gives a basic overview of terms used for locations over the vessel, while Figure 2-3 presents typical arrangements within a hull. Table 2-4 states the names for the numbers in Figure 2-3. Appendix J presents more detailed vessel drawings for the *Seven Seas*.

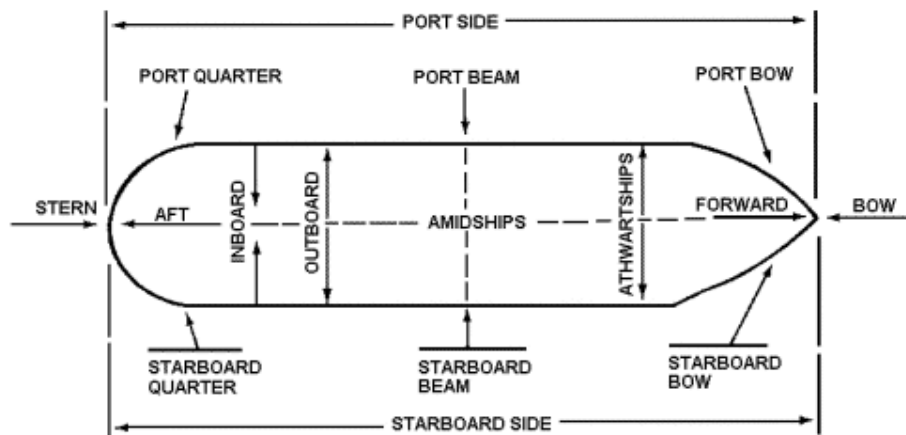

Figure 2-2: A basic overview of terms used for locations at a vessel.  
Taken from: <http://www.globalsecurity.org/military/systems/ship/hull.htm>

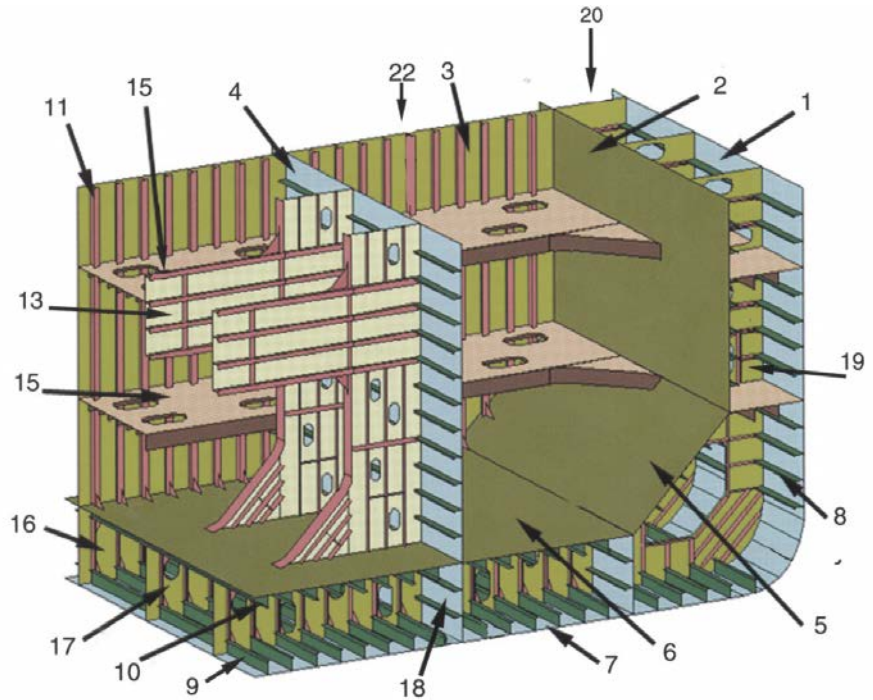

Figure 2-3: Presenting a section of a hull with longitudinal framing system.  
 Taken from [3], page 100

Table 2-4: Specifying the numbers in Figure 2-3.

<i>Plating</i>	<i>Stiffening on the plating</i>	<i>Plate stiffeners</i>	<i>Holds</i>
1) Shell (side plate)	8) Side longitudinal	13) Tie beam or cross-tie	20) Wing ballast tank
2) Longitudinal bulkhead	9) Bottom frame / Longitudinal	15) Stringer on deck	22) Cargo tank
3) Transverse bulkhead	10) Inner bottom longitudinal	16) Watertight floor	
4) Longitudinal bulkhead	11) Bulkhead stiffener	17) Full floor	
5) Lower hopper		18) Watertight side keelson	
6) Tank top		19) Webframe	
7) Bottom			

### 2.2.2.1 Hull Strength

A hull is stiffened up both transversally and longitudinally. Some elements contribute to the longitudinal strength and some to the transverse [4]. The 'global' horizontal loads and its correspondingly needed transverse strength are not considered in this thesis. The longitudinal strength of the vessel withstands the 'global' vertical bending moments and shear forces, and the longitudinal elements which contribute to this strength vary significantly for each vessel. Longitudinal elements which contribute to the longitudinal strength may commonly be [4]:

- Bottom and inner bottom plates
- Bilge plate
- Side plate (sheer strake plate included)
- Deck and inner deck plates
- Bulkheads/frames
- Stringers
- Girders
- Stiffeners (a large variation of stiffener profiles exists)

All of these elements are accounted for in estimations carried out in Section 3.3 and the Appendices.

When considering the stresses on a hull, certain structural members, including transverse bulkheads and frames must be incorporated into the vessel's structure to ensure adequate strength and to stiffen the vessel's cross section. The stiffened plate panels are key elements for the hull girder strength, and they consist of plate panels, longitudinal stiffeners, and transverse frames [5]. The requirements are that the panels shall be capable of absorbing these stresses without buckling or fracturing. The frames and bulkheads provide support to and interact with longitudinal members by transferring loads from one part of a structure to another [6]. For example, a portion of the bottom pressure loading on the hull is transferred via the center girder and the longitudinal frames to the transverse bulkheads at the ends of the frames. In turn, the bulkheads transfer these loads as vertical shears into the side plate [6]. Similarly concept, if side plates are subjected to stresses, these stresses will be transferred to the stiffeners, then transferred from stiffeners to the frame element, from the frame element to the deck or bottom structure [7].

The side plate of concern is located at the upper-most strake (located at the deck edge, at number 1 in Figure 2-3), and is referred to as the *sheer strake*. It is well known that the sheer strake experiences high stresses, so it is often constructed from higher strength materials or of thicker side plates than plates located at the lower side [8].

### **2.2.2.2 Side Structure**

The purpose of the side structure can be divided into two parts. Firstly, if we imagine the hull as a beam then the side structure serves as the web, together with the longitudinal bulkheads [9]. Secondly, the side structure is to take up the pressure difference between internal loads from the ballast tanks and external water pressure.

When later evaluating the side structure and disregarding welding, bolts and other smaller but important parts, we typically have an arrangement of stiffeners, frames/bulkheads, stringers and plates.

### **2.2.2.3 Bulkheads**

As we are evaluating the side plating area, it is important to understand bulkheads. Bulkheads are introduced in vessels in order to stiffen the bottom, deck and sides.

Some bulkheads, commonly called watertight bulkheads, are required in the hull, not only to stiffen up the vessel but also to subdivide compartments. These can be explained as vertically designed walls within the vessel's structure, starting from the vessel's double bottom and up until the main deck [10]. The function of these is that if one compartment of the hull starts to leak, the water will only fill up that compartment; hence the possibility of sinking the whole vessel is significantly reduced. The IACS' rules [11] demand that the following transverse watertight bulkheads are to be fitted in all vessels:

- A collision bulkhead (located in the bow region)
- An afterpeak bulkhead (after end bulkhead)
- A bulkhead at each end of the machinery space(s)

### **2.2.2.4 Stringers and Girders**

Stringers continue longitudinally along the side of the vessel, normally between the inner bottom plating and the inner deck plating. Their purpose is to stiffen up the side plate [8]. Deck girders continue longitudinally and stiffen the various deck plates in the hull. Possible location of stringers and girders are shown in both Figure 2-3 and in the thesis' selected webframe (Chapter 3).

### **2.2.2.5 Stiffeners**

The purposes of the stiffeners are to stiffen up and transfer stresses from the plates to the bulkheads/frames [7]. They will prevent the plate from buckling and/or yielding under the influence of the shearing loads, bending moments and local loads. Compared to the dimensions of the ship, the plating is not very thick (about 10 - 20 mm), thus it needs to be reinforced when it is subjected to in-plane and out-of-plane stresses.



### 2.2.3 Structural Vessel Responses

When evaluating a vessel's geometric arrangement and the resulting stress or deflection response patterns, it may be convenient to divide the structure and the associated response into three components, called primary, secondary and tertiary response. Taken from [6] and stated below are short descriptions of these responses accompanied by an illustration in Figure 2-4.

Secondary and tertiary responses are, however, illustrated for a double bottom and bottom plate, but the concept for outer side plates is comparable.

- *Primary response* is the response of the entire hull when bending and twisting as a beam, under the external longitudinal distribution of vertical, lateral, and twisting loads.
- *Secondary response* comprises the stress and deflection of a single panel of stiffened plating, i.e. the panel of the bottom structures contained between two adjacent transverse bulkheads, as shown in Figure 2-4.
- *Tertiary response* describes the out-of-plane deflection and associated stress of an individual panel of plating.

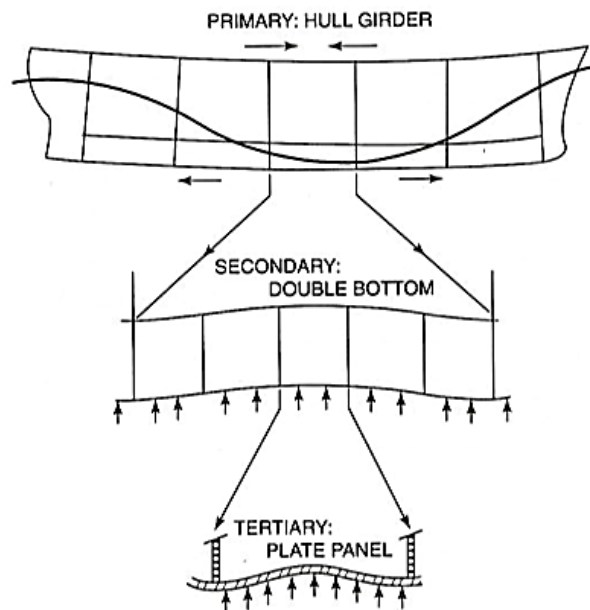

Figure 2-4: Primary, secondary and tertiary response structure.  
Taken from [6], page 6

## 2.3 BASIS OF GLOBAL STRUCTURAL LOADS

### 2.3.1 Main Description and Classification of Loads

There are many forces acting on a vessel. How they act is largely determined by the purpose for which the ship was built. Forces on a supply vessel will be different from the forces acting on a container vessel. The types of forces that occur in waves are the same for every vessel, but the magnitudes and points of action depend on the shape of the vessel below the waterline [3]. Usually the most difficult part of vessel structural design, is to correctly estimate the loads [8].

Ship structures are subjected to various types of loads, and these loads may be divided into four categories. These divided categories are grouped according to their characteristics over time, based partly upon the nature of the load and partly upon the nature of the vessel's response. The load categories are: static loads, low-frequency dynamic loads, high-frequency dynamic loads and impact loads [12].

*Static loads* are not considered to change over relatively short periods of time [8]. *Static loads* are those arising from [6, 8, 11]:

- The weight of the ship and its contents
- Static buoyancy of the ship when at rest or when moving
- Thermal loads resulting from nonlinear temperature gradients within the hull
- Concentrated loads caused by dry-docking and grounding.

*Low-frequency dynamic loads* are loads that vary over time with periods ranging from a few seconds to several minutes. They occur at frequencies that are sufficiently low compared to the frequencies of the vibratory response of the vessel's hull (also called Eigen frequency). This means that the resulting dynamic effects on the structural response are relatively small. The term 'dynamic loads' is used because the loads primarily come from the action of the waves through which the ship moves, and therefore are always changing with time. These dynamic loads may be divided into [6]:

- Wave-induced hull pressure variations
- Hull pressure variations caused by oscillatory ship motions
- Inertial reactions resulting from the acceleration of the mass of the ship and its contents.

*High-frequency dynamic loads* are time-varying loads of relatively high frequencies, frequencies that approach or exceed the lowest natural frequency of the hull girder. Some loads may be quite small in magnitude but, due to resonant amplification, can give rise to large stresses and deflections. Some examples of such dynamic loads are [6]:

- Hydrodynamic loads induced by propulsive devices on the hull or appendages
- Loads imparted to the hull by reciprocating or unbalanced rotating machinery
- Hydro-elastic loads resulting from the interaction of appendages with the flow past the ship

- Wave-induced loads primarily due to short waves whose frequency of encounter overlaps the lower natural frequencies of hull vibration and which therefore may excite an appreciable resonant response termed ‘springing’.

*Impact loads* are dynamic loads whose duration is even shorter than the period of the high-frequency dynamic loads. They are generally described as loads resulting from slamming or wave impact on the forefoot, bow flare, and other parts of the hull structure. Also, green water loads on deck may be included as impact loads. Impact loads may induce transient hull vibrations, defined as ‘whipping’ [6].

The most important classes of loads with regard to strength of ship are the static loads resulting from the ship’s weight and buoyancy, the low-frequency dynamic loads and slamming loads [6]. In addition to previously mentioned categories, some additional special operational loads can occur [6]:

- Equipment or structure sea-fastened and placed partly on deck and outside of the deck, causing shear forces and bending movement on the hull’s upper side shells
- Accidental loads caused by fire, collision, or grounding
- Sloshing and impact loads on internal structure caused by movement of liquids in tanks
- Ice loads in vessels intended for icebreaking or arctic navigation
- Loads caused by impact with other vessels, piers, or other obstacles
- Landing of aircraft or helicopters.

Since the characteristics of vessels’ structural loads vary significantly depending on loading, operating conditions and sea states, all potential conditions during the vessel’s lifetime must be taken into account in the analysis and design of vessel structures.

## 2.3.2 Bending Moments and Shear Forces along the Vessel

### 2.3.2.1 In Still Water

When a vessel is in calm water, the total buoyancy (vertical upward force) will equal the total weight (vertical downward force) of the vessel, illustrated in Figure 2-5. The figure shows upwards buoyancy pressure, with the weight of the ship indicated along the vessel. The larger arrows give the force resultant.

Locally the static equilibrium for buoyancy and weight will not exist because the vessel is not a rectangular homogeneous object. The buoyancy force is the result of hydrostatic pressure distribution over the external ship area; this pressure is a surface force per unit area working normal to the hull. As you can see from the basic illustration in Figure 2-5, this buoyancy distribution is not linearly distributed all over the vessel; for example, a section around amidships may be more submerged in the water (thus more affected by buoyancy) than the bow section. Accordingly, the weights forces working vertically downwards are distributed throughout the ship and its contents, with some sections of the vessel bearing more weight than others. For example, the section where the machinery is placed may be heavier than other sections of a vessel. The varying distribution in buoyancy and weight throughout a vessel causes bending moments and shear forces at sea and in still water [6].

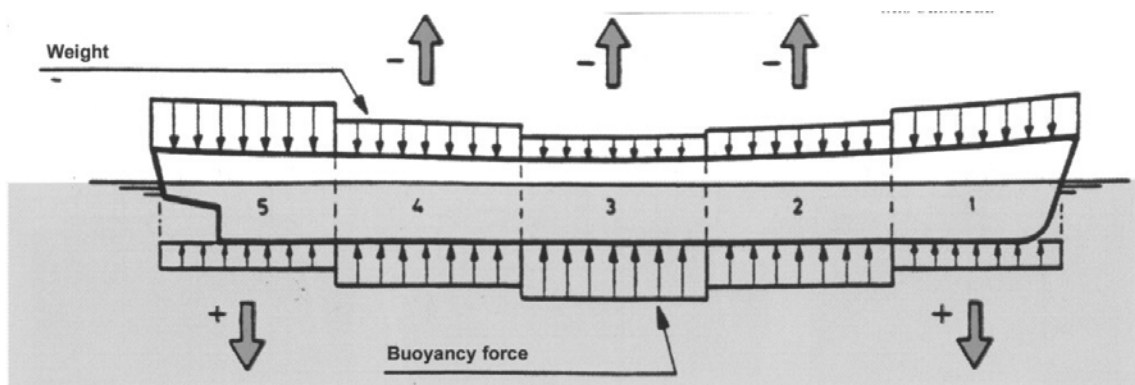

Figure 2-5: Buoyancy pressure and weight distribution of a simplified vessel  
Taken from [3], page 85

Sometimes it is desirable or necessary to know the localized distribution of the loads, for example, to identify the load per unit length for the entire hull. A simplified hypothesis of performing a response analysis is carried out by assuming that the entire hull of a ship behaves like a beam, which is loaded by longitudinal distribution of weights and buoyancy over the hull.

Figure 2-6 illustrates a longitudinal distribution of buoyancy and weight for a bulk carrier in calm water, and it clearly shows that weight and buoyancy are not in static equilibrium locally. The figure shows a curve of buoyancy force per unit length in the lower part of the figure. The upper part curve (2) in the figure shows the longitudinal distribution of the weight force, which is divided into around 20 equal station spaces. After having determined the buoyancy and weight distribution, the net load curve (3)

in the figure can be found. Curve 3 is the resulting difference between buoyancy and weight, with buoyancy force regarded as positive in upwards direction. The significance of the shear forces and bending moments are presented in the lower parts of the figure.

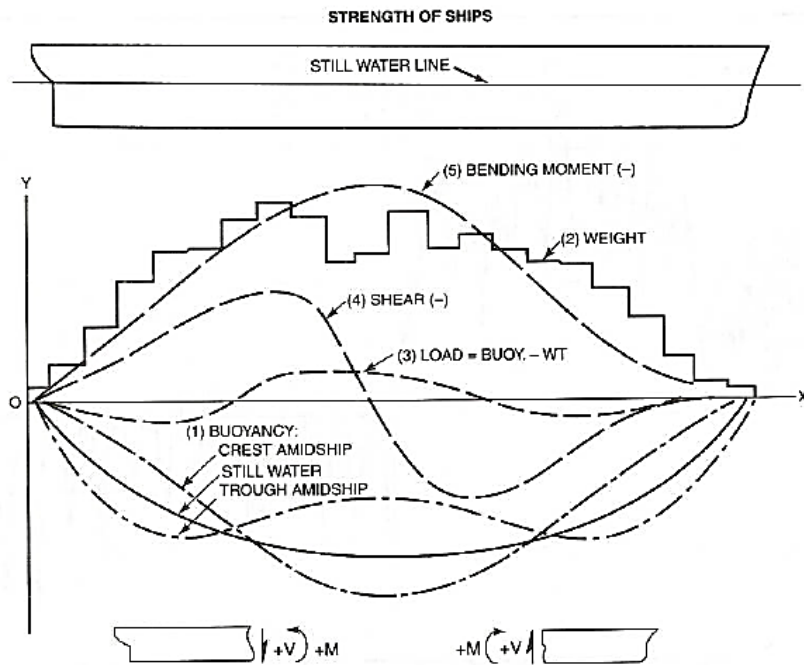

Figure 2-6: Longitudinal distribution loads on a bulk carrier.  
 Taken from [6], page 7

The condition of static equilibrium requires that the shear force and the bending moments must be equal to zero at both ends of the vessel.

### 2.3.2.2 In Waves

The longitudinal distribution of buoyancy applied to a vessel by a passing wave (or a vessel passing through a wave) creates bending moments and shear forces on the vessel, bending moments and shear forces which vary along the length of the ship. This is termed wave-induced buoyancy distribution [8]. The two extreme cases for wave-induced buoyancy distribution are called sagging and hogging.

#### Sagging and Hogging Condition

Both sagging and hogging should be evaluated when considering structural strength. These two conditions are expected as worst case loading conditions with respect to global loads. Generally, hogging creates tensile stress in the deck and compressive stress on the keel, and sagging creates compression stress in the deck and tensile stress on the keel, as illustrated in Figure 2-7.

The condition known as hogging occurs due to increased vertical upward buoyancy forces around the amidships point of the vessel, while vertical downwards gravitational forces occur around the stern and bow due to the vessel's metal structure. Similarly but opposite, sagging conditions occur when a vessel's stern and bow are being affected by increased vertical upward buoyancy forces and corresponding gravitational force working around amidships, making the vessel sag in the middle.

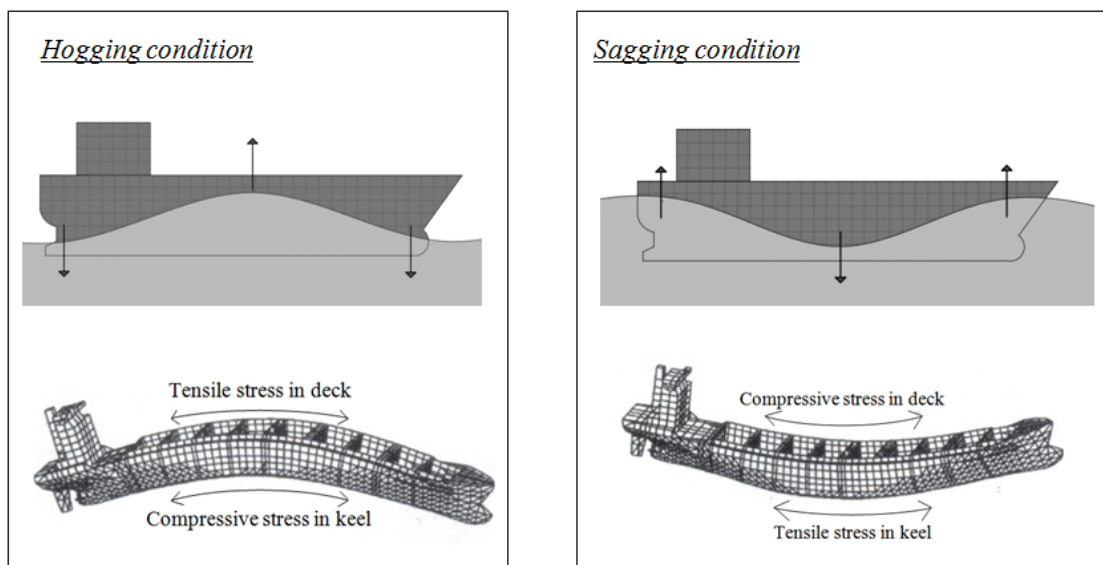

Figure 2-7: Hogging and sagging conditions.  
Taken from [3], page 97 and further designed in AutoCAD

Other dynamic loads which contribute to bending moments and shear forces are those introduced in Section 2.3.1. For example green water, slamming loads (whipping and springing). If the reader wants more information regarding these dynamic loads, references [6] and [9] can provide further descriptions.

### 2.3.3 Torsion Influence

Torsion occurs when there is an asymmetry in the mass distribution over the horizontal plane [3]. For example, if there is a weight of 200 tons on the starboard side on the forward area of the vessel, which is compensated by an equivalent weight on the port side on the aft area, there will be torsion [3]. In the case of adverse weather conditions, especially when the waves come in at an angle, the torsion can increase as a consequence of the asymmetric distribution of the buoyancy pressure; this means that there might be more upwards pressure on, for example, port than starboard side[3].

Torsion is a quite interesting phenomenon as this thesis is evaluating vessels that have a structure sticking out from port or starboard side. However, torsional stresses on the shell plating will not be included in this thesis. This torsional effect should be looked into by software programs and will be proposed as further work in Chapter 7.

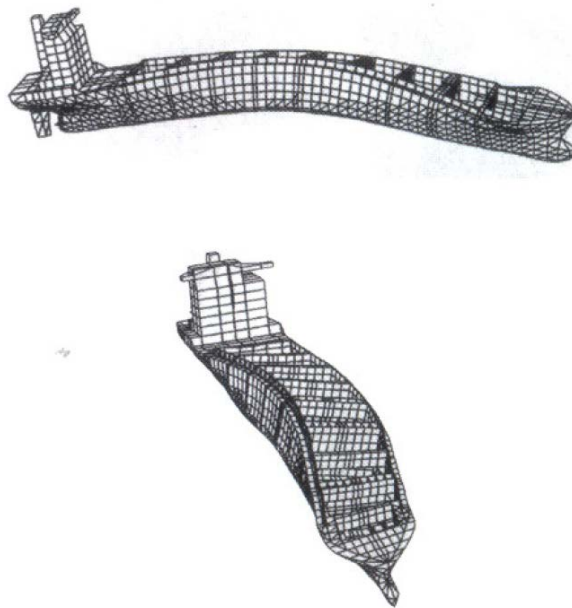

Figure 2-8: Torsion when waves are coming in from starboard at an angle.  
*Taken from [3], page 97*

### 2.3.4 Sea and Ballast Pressure

The pressure from ballast and sea under normal operating conditions is quite small compared to the in-plane stress. However small, it influences the plate's capacity because of its out-of-plane direction. The sea pressure will work on the hull at the bottom, keel and the side shells. The DNV [11] gives equations for finding the design sea pressure below and above the summer load waterline.

A DNV approach for finding the sea pressure above and below the summer load waterline is presented in Section 3.2.5 and estimated in Appendix F. These design results are based on extreme conditions with a probability of  $10^{-4}$  for being exceeded [11].

The ballast pressure is neglected in this thesis. The pressure from the ballast changes frequently as the ballast condition changes. The ballast pressure might work in the opposite direction of the sea pressure, making them counterbalance.

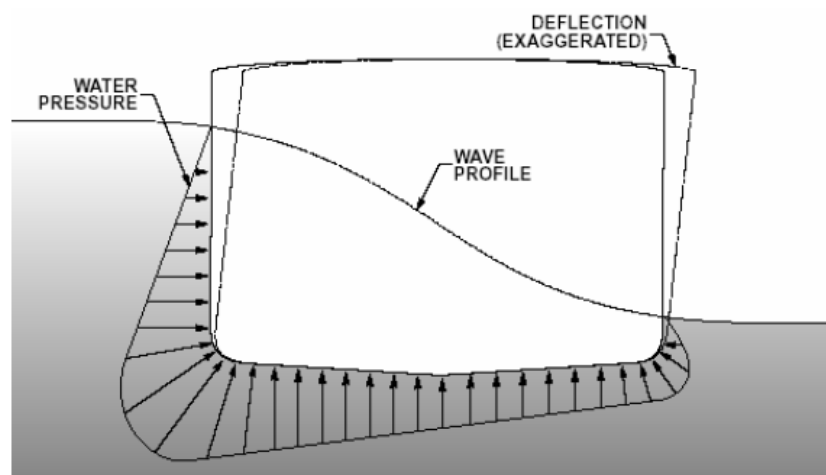

Figure 2-9: Sea pressure acting on a hull in wave.  
*Taken from [8], page 12.*



## 2.4 THE SIDE PLATE

### 2.4.1 Side Plate Arrangement

A side plate is typically surrounded by support members such as longitudinal stiffeners and transverse frames (or vertical side girders), thus implying that the rotational restraints at the plate edges are neither zero nor infinite [9]. Side plates in a vessel are likely to be subjected to both in-plane and out-of-plane loads. In-plane loads for a plate may be longitudinal axial compression/tension ( $\sigma_{x.sd}$ ), vertical compression ( $\sigma_{z.sd}$ ), and shear ( $\tau$ ) [9]. The definition of out-of-plane loads includes lateral pressures ( $P_{sd}$ ) that occur due to water and/or cargo pressure. Figure 2-10 and Figure 2-11 illustrate the basic arrangement and location of the plate, and the stresses working.

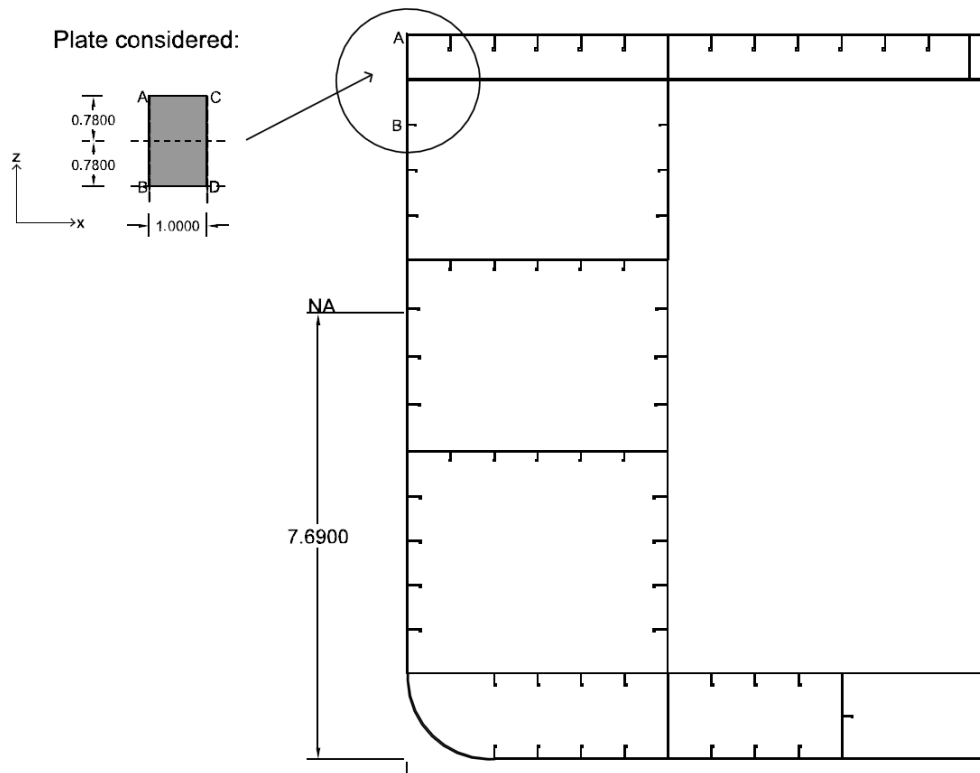

Figure 2-10: An illustration of the side plate at shear strake area.  
Designed in AutoCAD

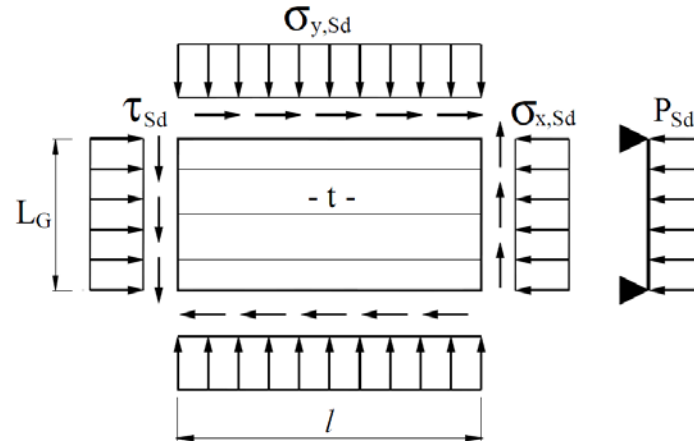

Figure 2-11: Longitudinal stiffened plate relevant stresses and pressure.  
 Taken from [13], page 10.

The in-plane vertical compression stresses that are working on the plate will, in our case, arise because of the structure on deck. The longitudinal axial compression/tension arises due to the vessel's longitudinal bending moments, compression and tension occurring from sagging and hogging respectively. Because the arising stresses on the plate are acting on the plate in more than one direction, von Mises equivalent stress should be considered [8, 9, 13].

According to the nomenclature, value  $\sigma_y$  in Figure 2-11 will in our case be the vertical stress  $\sigma_z$  arising from the structure on deck.  $\sigma_x$  will be the stresses arising from the global bending moments,  $\tau$  those arising from global shear forces, and  $P_{sd}$  from sea pressure.

## 2.4.2 Stiffened Plate Failures

The two main failure modes which need to be evaluated when performing a capacity check are yielding and buckling.

### 2.4.2.1 Yield Criteria

DNV [14] states the criteria for yield check as: “*Individual design stress components and von Mises equivalent design stress for plated structures shall not exceed the design resistance*”. They also specify that “*The level of safety of a structural element is considered to be satisfactory if the design load effect ( $S_d$ ) does not exceed the design resistance ( $R_d$ )*”.

$$S_d \leq R_d$$

The von Mises equivalent design stress for plated structures is defined as follows:

$$\sigma_{jd} = \sqrt{\sigma_{xd}^2 + \sigma_{zd}^2 - \sigma_{xd}\sigma_{zd} + 3\tau_d^2} \quad \{2.1\}$$

where:

- $\sigma_{xd}$  and  $\sigma_{zd}$  are design stresses in x- and z-direction respectively.
- $T_d$  is design shear stress in the x-y plane

Von Mises stresses will not be discussed in detail. If the reader requires more information regarding yield stress criteria or von Mises, this will be provided by references [8] and [13].

#### **2.4.2.2 Buckling**

Important parameters related to buckling are [5, 13, 15]:

- Length/width ratio of the panel/plate
- Stiffener geometry and spacing
- Aspect ratio for plate between stiffeners
- Plate slenderness
- Boundary conditions
- Initial imperfections
- Type of loading

Buckling can be regarded as compressive instability, and occur due to in-plane compressive stresses or shear stresses [13]. The load at which instability or buckling occurs is not necessarily with regard to material strength, but rather a function of member geometry and material modulus of elasticity [9]. A side plate or any plate in compression will also have a critical buckling load ( $F_{cr}$ ) whose value depends on the plate thickness, lateral dimension, edge support conditions, and material modulus of elasticity [9, 13].

A stiffened plate system that buckles during in-plane longitudinal compressive forces depends mainly on the stiffeners. The two main requirements are that they have sufficient torsional stability so that they do not buckle prematurely (i.e., before the plating) and that they have sufficient lateral rigidity so that global buckling is made sufficiently unlikely. For practical purposes, one can say that stiffener buckling is synonymous with global buckling, because, if the stiffeners buckle, the plating is left with almost no lateral rigidity between the vertical side girders (frames) [9]. Since a global buckling involves the buckling of a large part of the side structure, this kind of buckling may be regarded as collapse rather than as serviceability failure [9].

## **3 ESTABLISHMENT OF STRESSES AND PRESSURE ON THE PLATE**

### **3.1 APPROACH METHODS**

Stresses on a side plate may be established by several methods and with great complexity; the estimation can be performed by software programs (FEA), hand calculations and experimental methods, the former method presumably most used. The problem in question is quite complex with a large number of input parameters, and the entire webframe should therefore be modeled in FEA, with all the elements which contribute to the strength included [5]. The most adequate method for finding authentic stresses along the hull under specific conditions is by computer software; this requires the total modeling of the entire hull. Modeling a vessel's hull is highly time-consuming as all vessels are built differently; also the scope of this thesis is to establish a simplified calculation method and estimate stresses on side plating. Therefore, the method of modeling a specific vessel in computer software is not the selected approach.

Before presenting the selected numerical approach, the thesis will briefly introduce the main concepts of FEM analysis and strip theory, on which a variety of computer software is based on.

#### **3.1.1.1 Finite element analysis**

Designing the hull with finite element methods has been proposed by numerous researchers. There is no universal or unique approach that is commonly accepted in the FEM analysis [5]. The basic concept of strip theory is discussed, as the hypothesis is frequently used for hull structures.

### **Strip Theory**

The main concept of the strip theory method is to reduce the three-dimensional hydrodynamic problem to a series of two-dimensional boundary value problems that are easier to solve. The principle is to divide the underwater part of the vessel into a number of strips [16]. The two-dimensional forces for each strip are combined together to obtain the forces for the entire vessel. Software repeatedly uses linear or nonlinear time-domain strip theory to estimate wave-induced loads.

Strip methods are considered fast, cheap and reasonably accurate over a wide range of parameters [9]. Recent developments have shown improved comparison with experiments. However, they are still not entirely satisfactory [9]. The strip method is today considered to be a very practical design tool to assess global wave-induced loads, but it still has limitations. Strip theory is basically a high-frequency theory, and one of the limitations to be aware of is that the method fails for waves shorter than about one third of the vessel's length [9].

If the reader wants more information regarding FEA, this will be provided by references [5], [9] and [16].

## **3.2 SELECTED APPROACH METHOD**

### **3.2.1 General Guidance**

When analyzing the ship's response under global loads, the vessel's structure may be idealized as a hollow, thin walled box beam, referred to as "hull girder". The decks and bottom structures are considered as flanges and the side shell and any longitudinal bulkhead as webs [6].

Flexibility is rarely a problem for hulls of normal proportions constructed of mild steel; primary structures are designed with respect to strength rather than deflection [6]. However, IACS indirectly deals with this flexibility problem by specifying a limit on L/D ratio; if L/D exceeds 15, vessels must be specially considered [6].

The selected approach for establish the stresses on the shell plate from global loads systematically follow these steps:

- Establish bending moments and shear forces along the vessel (Section 3.2.2).
- Consider the webframe at the shell plate location and compute the moment of inertia and estimate the location of the neutral axis (Section 3.2.3).
- Apply beam theory to estimate the stresses on the plate (Section 3.2.4).
- Establish sea pressure acting on the side of a vessel by DNV rules (Section 3.2.5).

### **3.2.2 Establish Bending Moments and Shear Forces along Vessel**

Three different approaches are used to establish bending moments and shear forces along the hull. The bending and shear diagrams are found by means of the *Seven Seas* Stability Booklet, NAPA software onboard *Seven Seas*, and DNV's maximum allowable design values.

#### **3.2.2.1 The Stability Booklet**

A shipyard company should provide the service company with a Stability Booklet for each vessel. Strength diagrams and the corresponding bending and shear diagrams should be included in the booklet. Bending and shear diagrams for numerous loading cases should be presented, as well as vessel loading conditions which are likely to occur.

The ship yard company IHC Merwede presents the bending moments and shear forces along the *Seven Seas*' length in numerous different loading conditions. These strength diagrams are represented in Appendix B.

#### **3.2.2.2 NAPA Software and AutoHydro**

Previously mentioned in Section 2.2.1, supply vessels often have an integrated loading condition system onboard. The *Seven Seas*' integrated software is named NAPA. It may provide full reports and graphs of loading, longitudinal strength, stability and hull parameters. By request, the captain may provide longitudinal stability/strength results of the vessel. These longitudinal stability results and the corresponding bending and shear diagrams are considered as the most suitable for establishing real operating bending and shear diagrams along the *Seven Seas*. This method may be highly important when there are large structure(s) on deck because these structures will also influence the vessel's global bending moment and shear. A longitudinal stability result is presented in Appendix C.

AutoHydro is a software application available in the naval department in SS7. The function of the software is parallel to that of NAPA. For some vessels in SS7, it may provide full reports and graphs of loading, longitudinal strength, stability and hull parameters [17]. Weights on deck may be plotted into the software, also waves and wind velocity and direction may be specified [17].

In SS7, the *Seven Seas* is not currently available in AutoHydro. As the author, in the early stage of this study, selected *Seven Seas*, a loading condition is evaluated by using the NAPA software. A request has been made to the *Seven Seas*' Captain and First Officer to obtain a loading condition that may generate significant vessel bending moment and shear forces around amidships.

### 3.2.2.3 The DNV Classification Rules

This section presents the procedure for finding still-water bending moments, still-water shear forces, vertical wave bending moments and vertical wave shear forces. This section will use DNV [11, 18, 19] equations to separately and in combination estimate shear forces and bending moments when vessels are both in still water and in waves, more specifically. These formulas do not represent real-time applied bending moments and shear forces over a vessel's length during an actual operation; however, these bending moments and shear forces are considered by the DNV as the maximum allowable values for a given vessel. These bending moments and shear forces have a probability of  $10^{-8}$  for being exceeded, and the formulas have been created after numerous experiments and the collection of data over many years. The calculations and results for *Seven Seas* are presented in Section 3.3.2 and Appendix A. Figure 3-1 presents the sign convention for shear force ( $Q_s$ ) and bending moment ( $M_s$ ) for a still-water case.

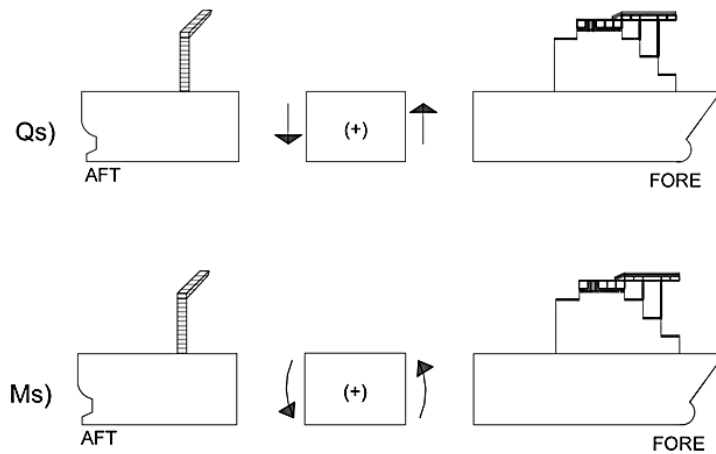

Figure 3-1: Bending moment ( $M_s$ ) and shear forces ( $Q_s$ ) sign conventions.  
 Based on drawing from [11], page 66, and designed in AutoCAD

### Still-Water Bending Moments

DNV [11] specify that the design still-water bending moments at arbitrary positions along the length of the ship for sagging and hogging should not to be taken less than:

$$M_s = k_{sm} M_{S0} \quad [\text{kNm}] \quad \{3.1\}$$

where  $M_{S0}$  can be found by:

$$\begin{aligned} M_{S0} &= -0.065 C_{wU} L^2 B (C_B + 0.7) && [\text{kNm}] \text{ in sagging} \\ &= C_{wU} L^2 B (0.1225 - 0.015 C_B) && [\text{kNm}] \text{ in hogging} \end{aligned}$$

and  $k_{sm}$  can be found by Figure 3-2 and as:

$$\begin{aligned} k_{sm} &= 1.0 \text{ within } 0.4 L \text{ amidships} \\ &= 0.15 \text{ at } 0.1 L \text{ from AP or FP} \\ &= 0.0 \text{ at AP and FP} \end{aligned}$$

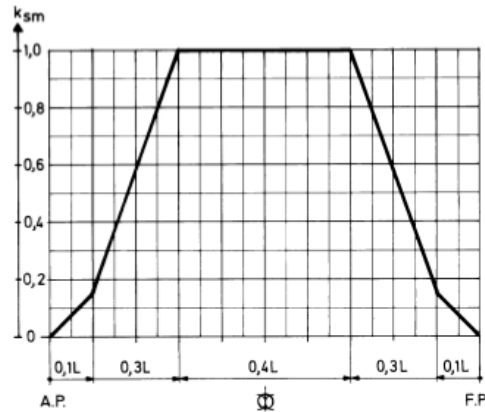

Figure 3-2: Still water bending moment distribution and variance.  
 (0,1 and 0,3 should be read as 0.1 and 0.3) Taken from [11], page 69

### Still-Water Shear Forces

Specified by DNV [11], the design values of still-water shear forces along the length of the ship are normally not to be taken less than:

$$Q_S = k_{sq} Q_{SO} \quad [\text{kN}] \quad \{3.2\}$$

$$Q_{SO} = 5 \frac{M_{SO}}{L} \quad [\text{kN}] \quad \{3.3\}$$

where:

$M_{SO}$  = Design still-water bending moments (sagging or hogging), see above

$k_{sq}$  = 0 at AP and FP  
 = 1.0 between 0.15 L and 0.3 L from AP  
 = 0.8 between 0.4 L and 0.6 L from AP  
 = 1.0 between 0.7 L and 0.85 L from AP

$k_{sq}$  varies linearly between specified positions.



### Vertical Wave Bending Moments

For stress analysis or buckling control, DNV [11] present the wave bending moments at arbitrary positions along the length of the ship for sagging and hogging. The bending moment should not be taken less than:

$$M_w = k_{wm} M_{wo} \quad [\text{kNm}] \quad \{3.4\}$$

where:

$$M_{wo} = -0.11\alpha C_w L^2 B (C_B + 0.7) \quad [\text{kNm}] \text{ in sagging}$$

$$= 0.19\alpha C_w L^2 B C_B \quad [\text{kNm}] \text{ in hogging}$$

$$k_{wm} = 1.0 \text{ between } 0.40 L \text{ and } 0.65 L \text{ from AP}$$

$$= 0.0 \text{ at AP and FP}$$

$$\alpha = 1.0 \text{ for seagoing conditions}$$

$$= 0.5 \text{ for harbor and sheltered water conditions}$$

$C_B$  is not to be taken less than 0.6.

For vessels at high speed, adjustment to  $k_{wm}$  is recommended; the adjustment is given in Table 3-1. Values for  $k_{wm}$  may also be obtained from Figure 3-3.

Table 3-1: Adjustment to  $k_{wm}$  when vessel is at high speed.

*Taken from [11], page 70*

	Sagging and hogging		Sagging only	
$C_{AV}$	$\leq 0.28$	$\geq 0.32$ <sup>1)</sup>		
$C_{AF}$			$\leq 0.40$	$\geq 0.50$
$k_{wm}$	No adjustment	- 1.2 between 0.48 and 0.65 L from AP - 0.0 at FP and AP	No adjustment	- 1.2 between 0.48 and 0.65 L from AP - 0.0 at FP and AP

1) Adjustment for  $C_{AV}$  not to be applied when  $C_{AF} \geq 0.50$

$$C_{AV} = \frac{c_v V}{\sqrt{L}}$$

$$C_{AF} = \frac{c_v V}{\sqrt{L}} + \frac{A_{DK} - A_{WP}}{Lz_f}$$

$$c_v = \frac{\sqrt{L}}{50}, \text{ maximum } 0.2$$

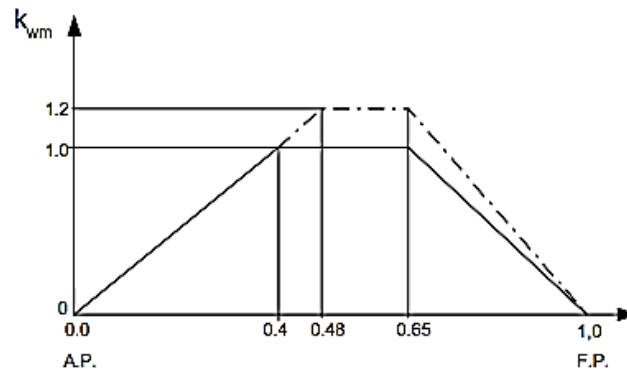

Figure 3-3: Wave bending moment distribution and variance.

*Taken from [11], page 70*

### Vertical Wave Shear Forces

According to DNV [11], the recommended vertical wave shear forces along the vessel's length are given as:

$$Q_{WP} = 0.3\beta k_{wqp} C_W LB(C_B + 0.7) \quad [\text{kN}] \quad \{3.5\}$$

$$Q_{WN} = -0.3\beta k_{wqn} C_W LB(C_B + 0.7) \quad [\text{kN}] \quad \{3.6\}$$

(Forces are positive ( $Q_{WP}$ ) when there is a surplus of buoyancy forward of the section considered and negative ( $Q_{WN}$ ) when there is a surplus of weight forward of the section considered.)

where:

$$\begin{aligned} \beta &= 1.0 \text{ for seagoing conditions} \\ &= 0.5 \text{ for harbor and sheltered water conditions} \\ k_{wqp} &= 0 \text{ at AP and FP} \\ &= \frac{1.59C_B}{C_B + 0.7} \text{ between } 0.2 \text{ L and } 0.3 \text{ L from AP} \\ &= 0.7 \text{ between } 0.4 \text{ L and } 0.6 \text{ L from AP} \\ &= 1.0 \text{ between } 0.7 \text{ L and } 0.85 \text{ L from AP} \\ k_{wqn} &= 0 \text{ at AP and FP} \\ &= 0.92 \text{ between } 0.2 \text{ L and } 0.3 \text{ L from AP} \\ &= 0.7 \text{ between } 0.4 \text{ L and } 0.6 \text{ L from AP} \\ &= \frac{1.73C_B}{C_B + 0.7} \text{ between } 0.7 \text{ L and } 0.85 \text{ L from AP} \end{aligned}$$

For vessels at high speed, DNV recommends adjustment to  $k_{wq}$ , given in Table 3-2 below.

Table 3-2: Adjusting  $k_{wq}$  for vertical shear forces.  
Taken from [11], page 71

	<b>Sagging and hogging</b>		<b>Sagging only</b>	
$C_{AV}$	$\leq 0.28$	$\geq 0.32$ <sup>1)</sup>		
$C_{AF}$			$\leq 0.40$	$\geq 0.50$
Multiply $k_{wq}$ by	1.0	- 1.0 aft of 0.6L from AP - 1.2 between 0.7 L and 0.85 L from AP	1.0	- 1.0 aft of 0.6 L from AP - 1.2 between 0.7 L and 0.85 L from AP

1) Adjustment for  $C_{AV}$  not to be applied when  $C_{AF} \geq 0.50$

$C_{AV}$  and  $C_{AF}$  defined in the section on "Vertical Wave Bending Moments".

Values for  $k_{wqp}$  and  $k_{wqn}$  may also be obtained from Figure 3-4.

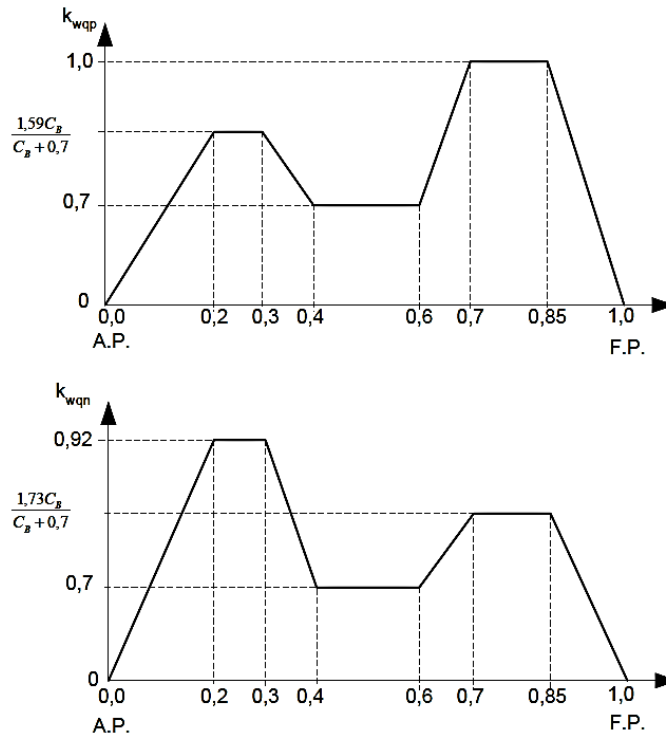

Figure 3-4: Wave shear force distribution and variance.  
 (0,0 should be read as 0.0) Taken from [11], page 71

### Combination Wave Loads with Local Stresses in Girder System, Stiffeners and Plating

Wave bending moments and shear forces may be reduced when hull girder stresses from wave loads are combined with local stresses. Stresses in girder systems, stiffeners and plating may be reduced to [11]:

$$M_{WR} = 0.59M_W \quad [\text{kNm}] \quad \{3.7\}$$

$$Q_{WR} = 0.59Q_W \quad [\text{kNm}] \quad \{3.8\}$$

### 3.2.3 Establish Neutral Axis and Moment of Inertia

There are many approaches for finding the neutral axis (NA) and moment of inertia ( $I_y$ ). Several computer programs may supply NA and  $I_y$  data, but modeling of the webframe is required. Computer programs that can be used include AutoCAD or DNV's Nauticus Hull. Alternatively, hand calculations are quite straightforward but time-consuming.

For hand calculations, the location of the neutral axis may be found by [8]:

$$Z_{NA} = \frac{\sum A_i Z_i}{\sum A_i} \quad \{3.9\}$$

The moment of inertia (2<sup>nd</sup> moment of inertia) is computed by the use of the parallel axis theorem. The moment of inertia about the cross section neutral axis is obtained by summing the moment of inertia of all the elements ( $I_i$ ) [8]:

$$I_y = \sum I_i = \sum \left( \frac{b_i h_i^3}{12} + A_i d_i^2 \right) \quad \{3.10\}$$

where:

- $A_i$  = Area of element
- $Z_i$  = Vertical distance from baseline to center of gravity for element
- $b_i$  = Horizontal breadth of element [m]
- $h_i$  = Vertical height of element [m]
- $d_i$  = Vertical distance from NA of webframe to center of gravity of an element

The definition of  $Z_{NA}$  and  $I$ , and the explanation of the corresponding Equations {3.9} and {3.10}, are fundamental knowledge in both civil and naval engineering and they will not be explained in further detail.  $Z_{NA}$  and  $I_y$  values greatly influence the result of the estimated bending stresses and shear stresses; therefore, both AutoCAD and hand calculations are performed. Results regarding  $Z_{NA}$  and  $I$  are presented in Section 3.3.3 and Appendix D.

### 3.2.4 Establish Stresses on Side Plate

#### 3.2.4.1 Bending Stress

Elementary Bernoulli-Euler beam theory is commonly used in estimating the component of primary stress due to vertical or lateral hull bending loads. Over the years, numerous experiments have been conducted and in many cases the results comply quite well with the simple beam theory. However, they may not comply in the vicinity of abrupt changes in the cross section [6].

In a simple beam theory approach, some underlying assumptions must be acquired. References [6] and [9] state these assumptions as:

- Plane cross sections remain plane and merely rotate as the beam deflects.
- Poisson effects on strain are neglected.
- The material behaves elastically, with the moduli of elasticity in tension and compression being equal. Also, longitudinal strain due to bending varies linearly over the cross section.
- Shear effects (stresses, strains) can be separated from, and do not influence, bending stresses or strains.
- Dynamic effects may be either neglected or accounted for by equivalent static loads.
- Since the bending strain is linear, the horizontal and vertical bending of the hull girder may be dealt with separately.

The equation for the bending moment  $M(x)$  for elastic small-deflection beam theory is [6, 20]:

$$\frac{d^2M}{dx^2} = f(x) \quad \{3.11\}$$

where  $f(x)$  is the loading on the beam expressed as a distributed vertical force.

Normal longitudinal elastic stress in a cross section is related to the bending moment and can be found by [6, 20]:

$$\sigma_x = \frac{M_x}{I_y} z \quad \{3.12\}$$

where:

- M - The vessel's global bending moment, and design bending moment ( $M_D$ ) can be found by [18, 21] and in Appendix A
- $I_y$  - The second moment of inertia, introduced in Section 3.2.3
- z - The vertical distance from the neutral axis to a specified point.

One of the problems in the use of Euler's beam equation is that the equation is somewhat limited, as it assumes that all the material in the moment of inertia calculations has the same stiffness (modulus of elasticity). An approach to include varying  $E$  in the Euler theorem exists; the method is not as accurate as using a higher-order method available in FEA, but it works well enough for preliminary design [8]. The method is often referred as 'composite beam' method by naval architects, or the equivalent area method by civil engineers [8]. An assumption will be made: all elements which contribute to the longitudinal strength for the selected *Seven Seas* webframe consist of the same modulus of elasticity. If the reader wants information regarding the equivalent area method, reference [8] can give a further description.

Figure 3-5 shows longitudinal bending stress across a multi-cell section under a hogging condition, + defined as tension and - defined as compression.

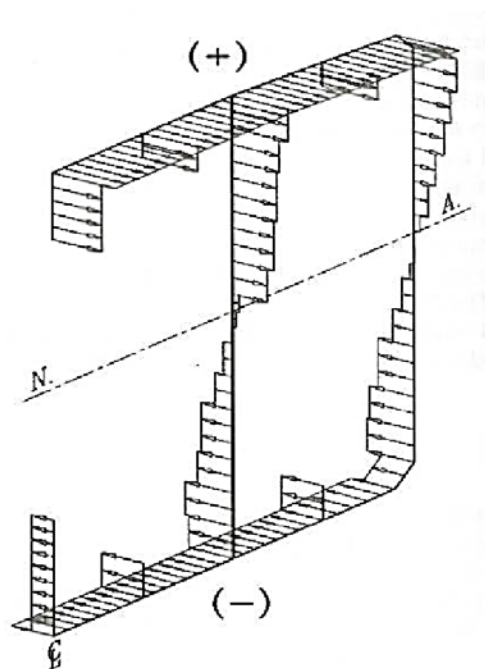

Figure 3-5: Bending stress across a multi-cell section under hogging condition  
 Taken from [9], page 16-8

### 3.2.4.2 Shear Stress

#### Complication of shear stresses

The basic equation of shearing stress in thin-walled members can be written as [8, 9, 20]:

$$\tau = \frac{Q \cdot q(y)}{I \cdot t(y)} \quad \{3.13\}$$

where:

- Q = vertical shear in the transverse section
- q(y) = first moment of the area above y
- I = second moment of inertia
- t(y) = width of the section at y.

The simple shear stress Equation {3.13} works well for small, open structural sections, such as those often used in civil engineering construction. However, vessel sections are neither small nor open, so a more detailed analysis is needed. Large vessel sections are closed and experience a characteristic called shear flow [9]. It is highly important to account for shear flow in a hull's section, as this has caused a number of vessel structural failures in the past [8].

How exactly are shear forces transmitted through the vessel's section and into shear stress? Like a solid rectangular beam section, it is not constant across the section, but it is a complex thin-walled structure [8]. Essentially, it is similar to but more complicated than a solid beam section. The shear stress (or shear flow) for a large vessel section can be imagined to flow around the thin-walled section of the box beam [8]. Shear flow for a simply large closed section is numerically obtainable, but if the section has several elements within it which also withstand shear, the procedure is quite complex. In this case a multi-cell shear flow approach should be considered [8, 9].

Multi-cell shear flow is considered when a vessel has multiple decks or longitudinal bulkheads, and where width t varies around the cross section [8]. Figure 3-6 illustrates a basic multi-cell concept (in this case a closed section with bulkhead). The figure shows how the shear flow increases as the distance from the deck or centerline increases. At the point where the upper deck intersects with the shell plating (at sheer strake area), that load must be transferred into the plate. At this intersection the shear flow from the decks above is added in, creating a so-called 'jump in shear flow' [8].

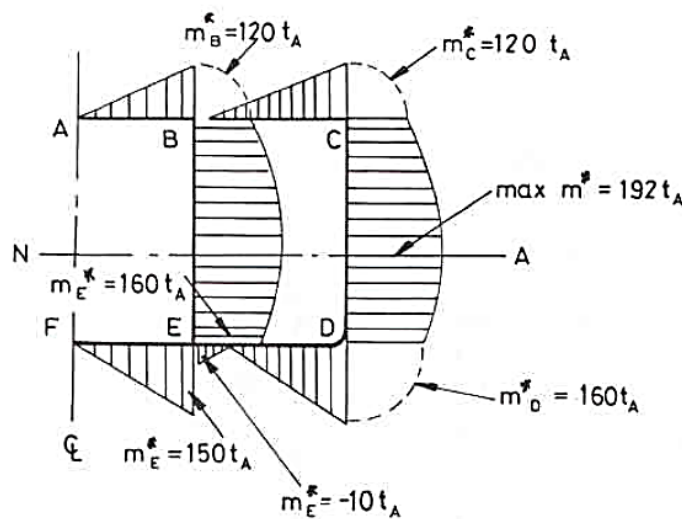
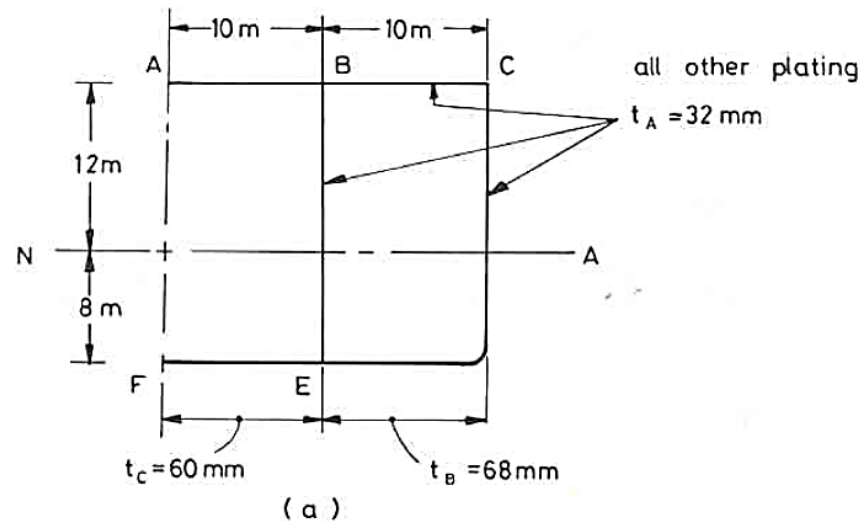

Figure 3-6: Shear flow for a vessels multi-cell section.  
Taken from [8], page 42

The shear flow builds up linearly until it reaches the intersection of the deck with the longitudinal bulkhead, shown in Figure 3-6. A challenge in this case is, how much goes through the bulkhead and how much goes through the deck plating? The difficulty arises because the shear flow divides at point B and reunites at point E [9]. The shear flow from AB and FE can be obtained statically, but the shear for part BCDEB is statically indeterminate [9]. It is possible to find the shear stresses at BCDEB in accordance with the approach presented in [9], but this approach is quite complex. The problem is, a multi-cell section is a structurally statically indeterminate problem, and to obtain an answer, we must define it as statically determinate.



*Seven Seas* webframe 72 is quite large and complicated. The section considered in this thesis does not only include longitudinal bulkheads, but also inner deck, inner bottom and girders, which also contribute to the shear flow. The approach for a multi-cell section should be performed to obtain the most accurate shear values, but assumptions are made to avoid this complex approach. The approach for a multi-cell indeterminate problem is further described in reference [9].

### Shear stress approximation

The basic Equation {3.13} of shearing stress in thin-walled members is used:

$$\tau = \frac{Q \cdot q(y)}{I \cdot t(y)}$$

First moment of inertia ( $q$ ) is estimated by hand calculations presented in Appendix D.

$$q = \sum A_i d_i \tag{3.14}$$

where:

- |       |   |   |
|-------|---|---|
| $A_i$ | - | Area of element   |
| $d_i$ | - | Vertical distance from NA of webframe to center of gravity of element |

As regards the selected thickness, DNV [11] specifies that when considering sheer strake at strength deck, the thickness shall not be less than:

$$t_{ave} = \frac{t_1 + t_2}{2} \tag{3.15}$$

where:

- |       |   |                                 |
|-------|---|---------------------------------|
| $t_1$ | - | Thickness of sheer strake plate |
| $t_2$ | - | Thickness of deck plate         |

### 3.2.5 Establish Sea Pressure

This section presents a procedure for finding sea pressure that is acting on shell plating. DNV's Rules for Classification of Ships Part 3 Chapters 1 [11] is used. Calculations for *Seven Seas* sea pressure on the side are presented in Appendix F.

DNV specify that the design sea pressure is assumed to be acting on the ship's outer panels (shell) at full draught [11]. The design sea pressures are based on extreme conditions with a probability of  $10^{-4}$  for being exceeded [11]. Impact pressures caused by the sea (i.e. slamming and bow impact) are not covered by Equations {3.16} and {3.17}. This is not included because impact pressures depend greatly on the vessel's shape and the weather conditions, and thus cannot be obtained with a common equation.

The plate of interest to this thesis is located above the waterline. However, the thesis will include the pressure below and above the waterline. The computed sea pressure acting on the ship's side shall be taken as the sum of the static and the dynamic pressure [11].

Compute sea pressure above summer load waterline by:

$$p_2 = a(p_{dp} - (4 + 0.2k_s)h_0) \quad [\text{kN/m}^2] \quad \{3.16\}$$

Note:  $p_2 = \text{minimum } 6.25 + 0.025 L_1$  for sides

Compute sea pressure below summer load waterline by:

$$p_1 = 10h_0 + p_{dp} \quad \{3.17\}$$

Determine the pressure  $p_{dq}$ :

$$p_{dq} = p_L + 135 \frac{x_1}{B + 75} - 1.2(T - z_1) \quad [\text{kN/m}^2] \quad \{3.18\}$$

Determine the pressure  $p_L$ :

$$\begin{aligned} p_L &= k_s C_w + k_f \\ &= (k_s C_w + k_f) \left(0.8 + 0.15 \frac{V}{\sqrt{L}}\right) \quad \text{if } \frac{V}{\sqrt{L}} > 1.5 \end{aligned}$$

Determine  $k_s$ :

$$\begin{aligned} k_s &= 3C_B + \frac{2.5}{\sqrt{C_B}} \\ &= 2 \text{ between } 0.2 \text{ and } 0.7 L \text{ from AP} \\ &= 3C_B + \frac{4.0}{C_B} \text{ at FP and forward} \end{aligned}$$

Note:  $k_s$  varies linearly between specified positions

Parameters:

$a$  = 1.0 for ship's sides and for weather decks forward of 0.15 L from FP.

$k_f$  = The smallest of T and f. f is defined as the vertical distance from the waterline to the top of the ship's side at transverse section considered, maximum  $0.8C_w$  [m].

$x_1$  = The horizontal distance from center line to load point

$z_1$  = The vertical distance from baseline to load point

### 3.3 RESULTS: AN ESTIMATION OF STRESSES ON PLATE

#### 3.3.1 Design Basis

##### 3.3.1.1 Seven Seas Data

The parameters stated in Table 3-3 are obtained from the ship yard company Merwede [2]. Figure 3-7 and Figure 3-8 present the general arrangement of the *Seven Seas*; enlarged and additional drawings are included in Appendix J.

Table 3-3: General *Seven Seas* characteristics.  
Taken from [2], page 5

<b>Seven Seas characteristics</b>	
Length between perpendiculars	142.08 [m]
Depth to main deck	12.50 [m]
Beam molded	28.40 [m]
Keelplate thickness amidships	15 [mm]
Average shell plate thickness	10 [mm]
Deckplate thickness amidships	36 [mm]
Draft design	7.50 [m]
Block coefficient (design draft)	0.797 [-]
Deadweight (design draft)	11.366 [ton]

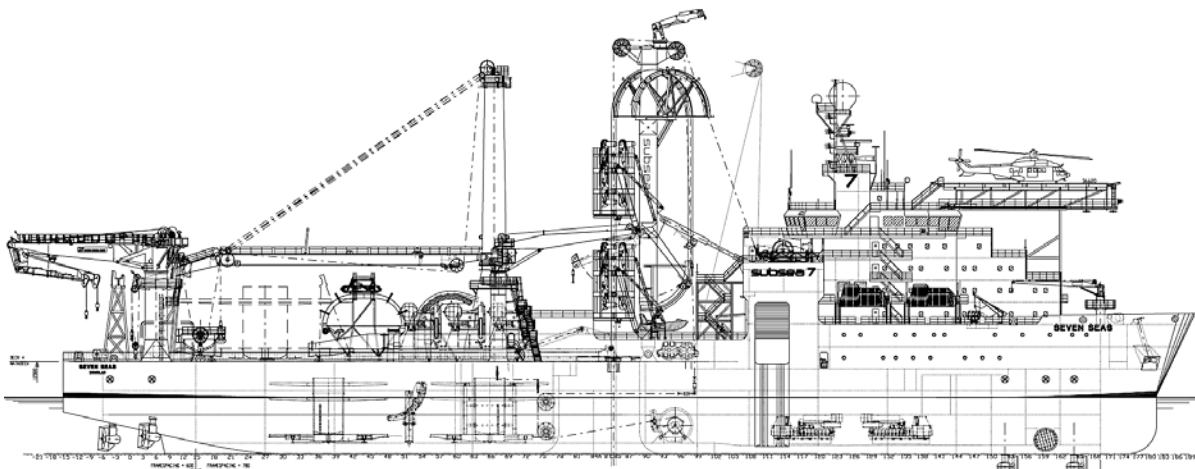

Figure 3-7: *Seven Seas* from starboard side view.  
Taken from [2], Appendix J.

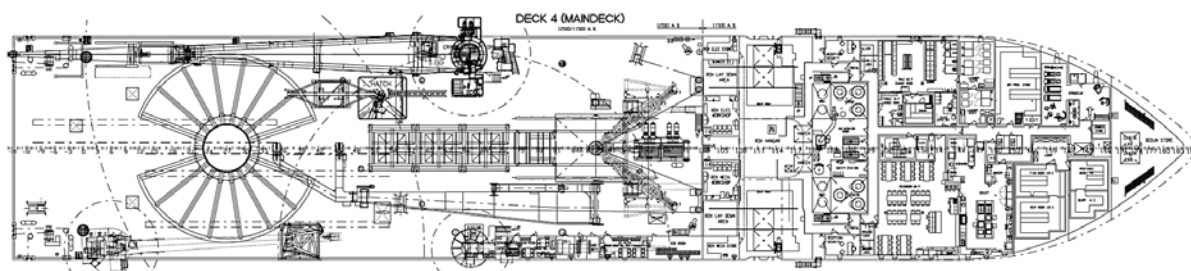

Figure 3-8: *Seven Seas* main deck (deck 4) arrangement.  
Taken from [2], Appendix J.

The main deck arrangement presented in Figure 3-8 indicates that there may be some space for a structure on deck on the port side, at an area of from 70 to 100 meters from the AP. This area is also around amidships, an area that might give large bending moments and considerable shearing stress, depending on the *Seven Seas*' loading condition.

### 3.3.1.2 Considered webframe

Figure 3-9 presents the *Seven Seas*' hull's webframe at 72 meters from the AP. As shown in Figure 3-9 the hull/webframe consists of several elements. The elements in this webframe which contribute to the longitudinal stiffness are:

- The longitudinal stiffeners (in our case HP profiles)
- Bottom-, inner bottom-, side-, inner deck-, and deck-plates
- Longitudinal bulkheads and center bulkheads
- Stringer plates

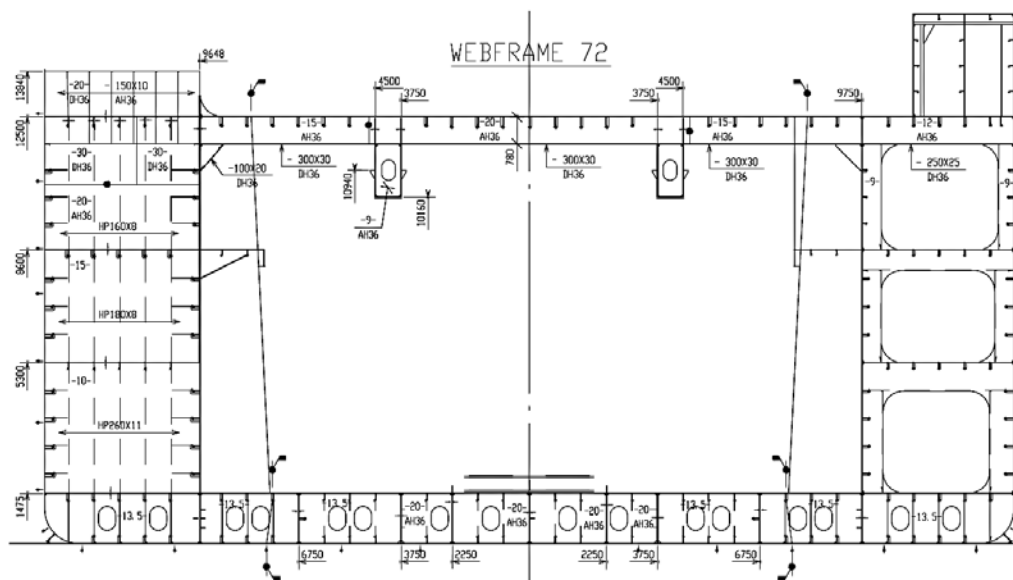

Figure 3-9: Webframe 72 in *Seven Seas*.  
Taken from [2], Appendix J.

The elements contributing to the longitudinal strength and the location of the plate which is to be evaluated in Chapter 4 are shown in Figure 3-10.

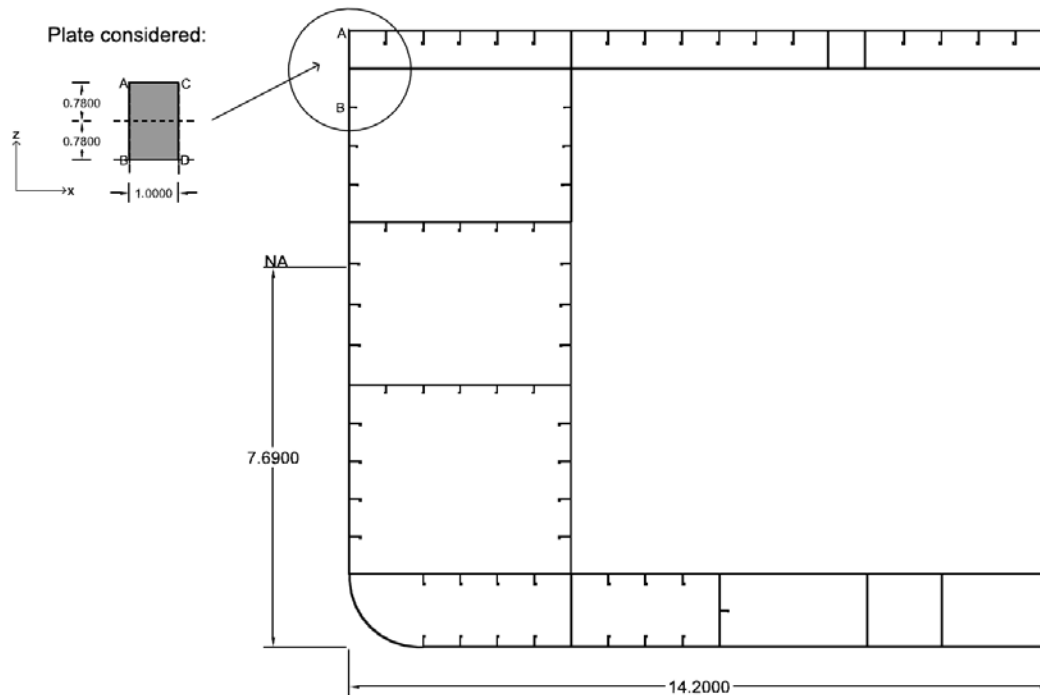

Figure 3-10: Webframe 72 and arrangement of the stiffened plate.  
*Created in AutoCAD*

### 3.3.1.3 Assumptions:

- All elements in the webframe are assumed to have the same modulus of elasticity (E). The material behaves elastically, with the modulus of elasticity in tension and in compression being equal.
- Transverse (Poisson) effects on strain are neglected.
- Shear effects (stresses, strains) can be separated from, and do not influence, bending stresses or strains.
- The bending stress and shear stress are equal on both sides of the plate.
- The longitudinal girders between bottom and inner bottom and between deck and inner deck are assumed to have 18 mm thickness.

### 3.3.2 Bending Moments and Shear Forces

Bending moments and shear force at 72 meters from the AP are presented in this section. The DNV maximum design values are obtained from calculations in Appendix A and presented in Table 3-4. The bending moments and shear forces from the Stability Booklet (Appendix B) are presented in Table 3-5. The bending moments and shear forces from NAPA software are presented in Table 3-6.

**Table 3-4: Bending moments and shear forces at 72m from AP.**  
*Obtained from numerical calculations in Appendix A*

<b>Loading conditions from DNV</b>	<b>Bending moment, M [kNm]</b>		<b>Shear force, Q [kN]</b>	
	<i>Sagging</i>	<i>Hogging</i>	<i>Sagging</i>	<i>Hogging</i>
<i>Still-water</i>	-489000	55500	-13800	15600
<i>Vertical wave in sheltered condition</i>	-244100	224500	-3300	3300
<i>Vertical wave in seagoing condition</i>	-488200	449000	-6600	6600
<i>Combined still-water and vertical wave seagoing, Load combination 1</i>	-928500	980900	-21100	23400
<i>Combined still-water and vertical wave seagoing, Load combination 2</i>	-1050000	1072000	-21300	23200

**Table 3-5: Bending moments and shear forces at 72m from AP.**  
*Taken from strength diagrams in Appendix F*

<b>Loading conditions from Stability booklet</b>	<b>Bending moment, M [kNm]</b>	<b>Shear force, Q [kN]</b>
<i>Condition 1</i>	-40000	1900
<i>Condition 2</i>	0	0
<i>Condition 4</i>	-131000	-2500
<i>Condition 5</i>	-6000	6200
<i>Condition 6</i>	0	-3700
<i>Condition 7</i>	-98000	0

**Table 3-6: Bending moments and shear forces at 72m from AP**  
*Taken from longitudinal strength diagram in Appendix C (NAPA software)*

<b>Loading condition from NAPA</b>	<b>Bending moment, M [kNm]</b>	<b>Shear forces, Q [kN]</b>
Still-water lightship condition with 400 tons deck load at aft and 200 tons deck load at webframe 72	-176600	8800

### 3.3.3 Neutral Axis and Moment of Inertia

The location of the neutral axis (NA) and the moment of inertia around the y-axis ( $I_y$ ) are found by the use of AutoCAD and hand calculations. The values in AutoCAD are validated by the use of Equations {3.19} and {3.20} in Appendix D.

$$Y = \frac{\sum A_i Y_i}{\sum A_i} \quad \{3.19\}$$

$$I_y = \sum I_{yi} = \sum \left( \frac{b_i h_i^3}{12} + A_i d_i^2 \right) \quad \{3.20\}$$

When collecting data from AutoCAD, it is adequate to present  $Z_{NA}$  and  $I_y$  in two separate figures.  $Z_{NA}$  is found in Figure 3-11 and  $I_y$  is found in Figure 3-12.

Table 3-7 validates the estimated “ $I_y$ ” and “ $Z_{NA}$ ” by comparing the values from AutoCAD and the performed hand calculations. Also, DNV [11] specifies general requirements for “ $I_y$ ” and section modulus for a vessel with a given length, breadth, block coefficient and wave load coefficient.

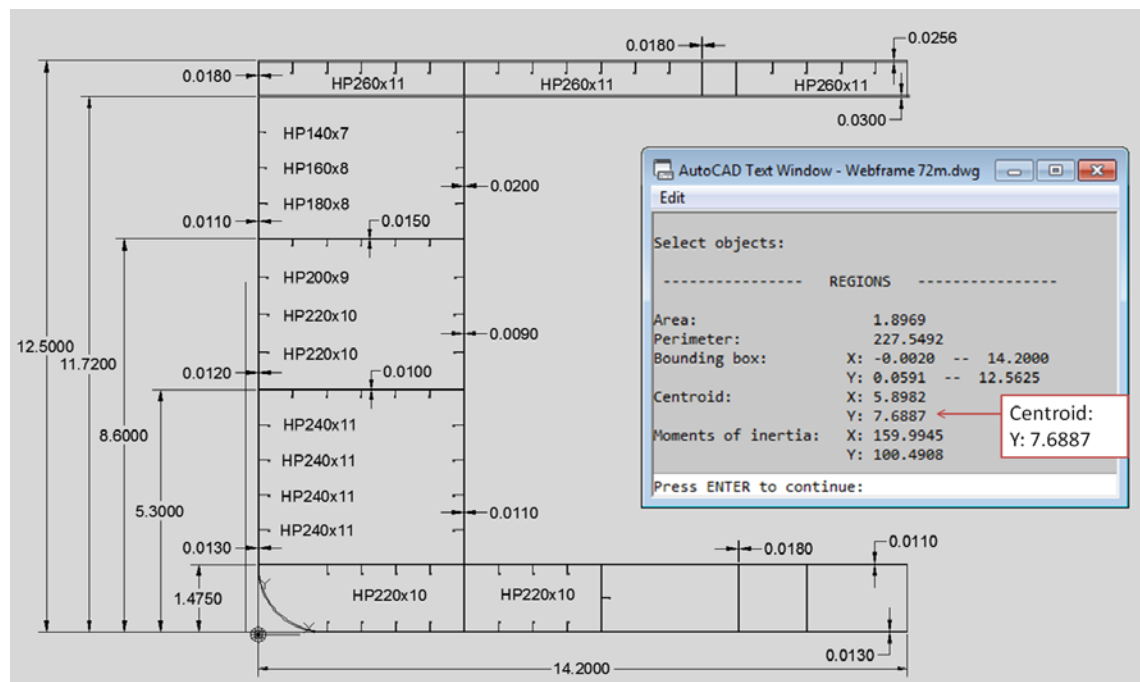

Figure 3-11: Estimated vertical distance ( $Z_{NA}$ ) for the webframe.  
Webframe designed and data collected in AutoCAD



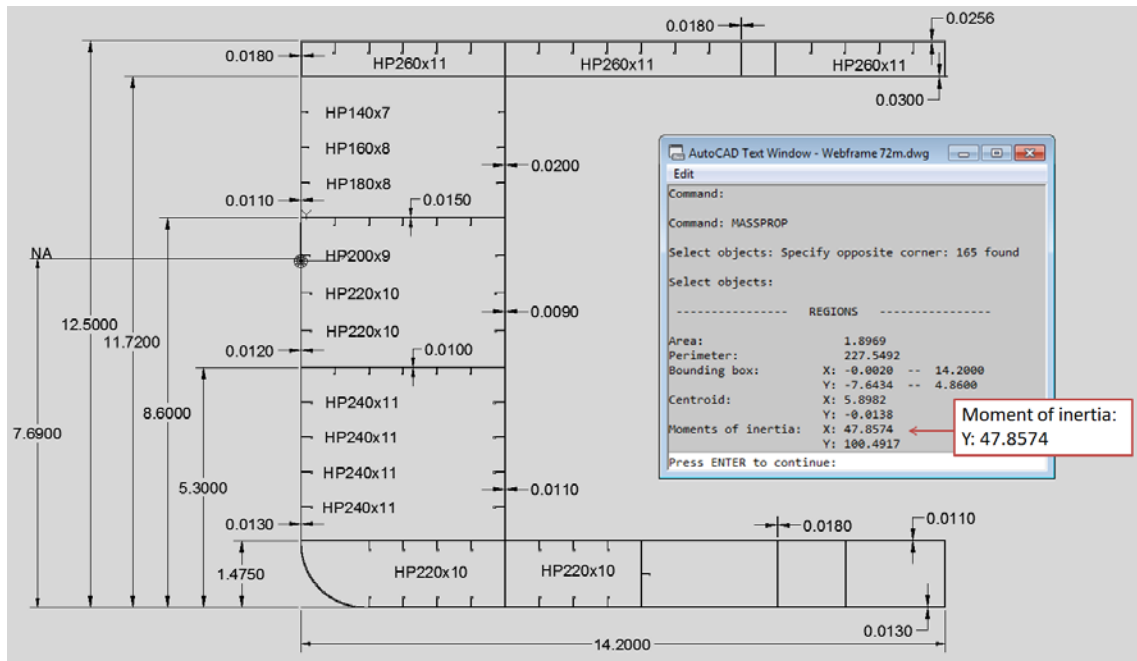

Figure 3-12: Estimated half of the moment of inertia for the webframe.  
Webframe designed and data collected in AutoCAD

$$I_{y,AutoCad} = 2 \cdot 47.86 = 95.7m^4$$

### 3.3.3.1 Results: location of neutral axis and moment of inertia

Table 3-7 compares the estimated  $Z_{NA}$  and  $I_y$  and also, if available, checks these values against the DNV requirements.

Table 3-7: Comparing the estimated  $Z_{NA}$  and  $I_y$ .  
Data obtained from Appendix D

	<i>AutoCAD</i>	<i>Numerical approach</i>	<i>Required by the DNV</i>	<i>Comment</i>
$Z_{NA} [m]$	7.69	7.61	-	The values coincide
$I [m^4]$	95.72	94.81	32.08	The values coincide and requirements are fulfilled
$SM[m^3]$	12.4	12.4	5.57	The values coincide and requirements are fulfilled

### 3.3.4 Stresses on the Plate

The estimation of bending stress and shearing stresses are performed in calculations in Appendix E. The locations of points A, B, C and D on the plate are shown in Figure 3-10.

#### 3.3.4.1 Stresses at point A and C

The DNV maximum design stresses are presented in Table 3-8. The stresses from loading conditions in the Stability Booklet are presented in Table 3-9. The stresses from the NAPA software are presented in Table 3-10.

Table 3-8: Estimated design stresses at point A and C, DNV approach.  
Values calculated in Appendix E

Loading conditions from DNV	Bending stress ( $\sigma_{x,A}$ ) [MPa]		Shear stress ( $\tau$ ) [MPa]	
	Sagging	Hogging	Sagging	Hogging
Still-water	-2.5	2.8	-51.6	58.4
Vertical wave in sheltered condition	-12.3	11.3	-12.3	12.3
Vertical wave in seagoing condition	-24.5	22.6	-24.7	24.7
Combined still-water and vertical wave seagoing, Load combination 1	-46.7	49.3	-78.9	87.6
Combined still-water and vertical wave seagoing, Load combination 2	-52.8	53.9	-79.7	86.8

Table 3-9: Estimated stresses at point A and C, Stability Booklet approach.  
Values calculated in Appendix E

Loading conditions from Stability booklet	Bending stress ( $\sigma_{x,A}$ ) [MPa]	Shear stress ( $\tau$ ) [MPa]
Condition 1	-2.0	7.1
Condition 2	0.0	0.0
Condition 4	-6.6	-9.4
Condition 5	-0.3	23.2
Condition 6	0.0	-13.8
Condition 7	-4.9	0.0

Table 3-10: Estimated stresses at point A and C, NAPA approach.  
Values calculated in Appendix E

Loading condition from NAPA	Bending stress ( $\sigma_{x,A}$ ) [MPa]	Shear stress ( $\tau$ ) [MPa]
Still-water lightship condition with 400 tons at aft and 200 tons at webframe 72	-8.9	32.9

### 3.3.4.2 Stresses at point B and D

The DNV maximum design stresses are presented in Table 3-11. The stresses from loading conditions in the Stability Booklet are presented in Table 3-12. The stresses from the NAPA software are presented in Table 3-13.

Table 3-11: Estimated design stresses at point B and D, DNV approach.  
Values calculated in Appendix E

Loading conditions from DNV	Bending stress ( $\sigma_{x,B}$ ) [MPa]		Shear stress ( $\tau$ ) [MPa]	
	Sagging	Hogging	Sagging	Hogging
Still-water	-1.7	1.9	-51.6	58.4
Vertical wave in sheltered condition	-8.3	7.6	-12.3	12.3
Vertical wave in seagoing condition	-16.6	15.2	-24.7	24.7
Combined still-water and vertical wave seagoing, Load combination 1	-31.5	33.3	-78.9	87.6
Combined still-water and vertical wave seagoing, Load combination 2	-35.7	36.4	-79.7	86.8

Table 3-12: Estimated stresses at point B and D, Stability Booklet approach.  
Values calculated in Appendix E

Loading conditions from Stability booklet	Bending stress ( $\sigma_{x,B}$ ) [MPa]	Shear stress ( $\tau$ ) [MPa]
Condition 1	-1.4	7.1
Condition 2	0.0	0.0
Condition 4	-4.4	-9.4
Condition 5	-0.2	23.2
Condition 6	0.0	-13.8
Condition 7	-3.3	0.0

Table 3-13: Estimated stresses at point B and D, NAPA approach  
Values calculated in Appendix E

Loading condition from NAPA	Bending stress ( $\sigma_{x,B}$ ) [MPa]	Shear stress ( $\tau$ ) [MPa]
Still-water lightship condition with 400 tons at aft and 200 tons at webframe 72	-6.0	32.9

### 3.4 RESULTS: AN ESTIMATION OF SEA PRESSURE

Design sea pressure acting on the side structure is calculated with accordance to DNV [11] in Appendix F. Figure 3-13 and Table 3-14 presents how the estimated design sea pressures vary over the side structure. The result gives the design sea pressure ( $p_{sd}$ ) on the local plate as 0.02 MPa.

Table 3-14: Estimated sea pressure acting on the *Seven Seas* side shell.  
*Obtained from Appendix D*

<i>Load point</i>	<i>Distance from baseline to load point [m]</i>	<i>Pressure [MPa]</i>
<i>1.0(D-T)</i>	12.5	0.02
<i>0.8(D-T)</i>	11.5	0.02
<i>0.6(D-T)</i>	10.5	0.03
<i>0.4(D-T)</i>	9.5	0.03
<i>0.2(D-T)</i>	8.5	0.03
<i>Waterline</i>	7.5	0.04
<i>0.2T</i>	6	0.05
<i>0.4T</i>	4.5	0.07
<i>0.6T</i>	3	0.08
<i>0.8T</i>	1.5	0.09
<i>Baseline</i>	0	0.10

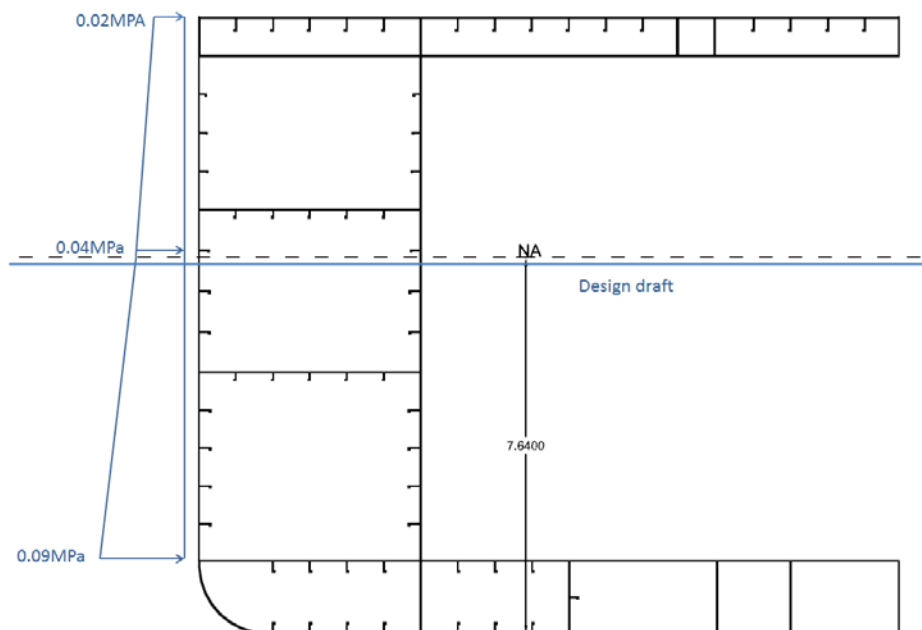

Figure 3-13: Sea pressure on *Seven Seas* side.  
*Designed in AutoCAD*

### 3.5 SUMMARY

The stresses arising on the side plate greatly depend on the loading condition. DNV's rule for design bending moments and shear forces causes substantial bending stresses and shear stresses. Load combination 2 is a combination of both still-water and vertical wave loads and is the loading case which gives the largest stresses on the plate. Longitudinal stresses in sagging condition are approximately up to 53 MPa in compression and in hogging condition approximately up to 54 MPa in tension. Shear stresses in sagging condition are approximately up to 83 MPa in compression and in hogging condition approximately up to 54 MPa in tension. However, these values represent approximately 20-year return period and do not represent normal operation conditions.

The stresses on the plate arising from *Seven Seas*' load conditions 4-7 in the Stability Booklet (Appendix B) clearly show that the global stresses on the plate change when the vessel's fuel changes. These stresses represent operations during which the significant wave height is expected not to exceed 3-4 meters. Figure 3-14 presents the stresses on the plate during a fuel change for *Seven Seas* in a sailing condition – loaded for flex lay, no deck carousel. The figure does not give a comprehensive overview of stresses on the plate due to fuel change in other loading conditions, but it does clearly show that the stresses do indeed change during fuel change for “sailing condition – loaded for flex lay no deck carousel”.

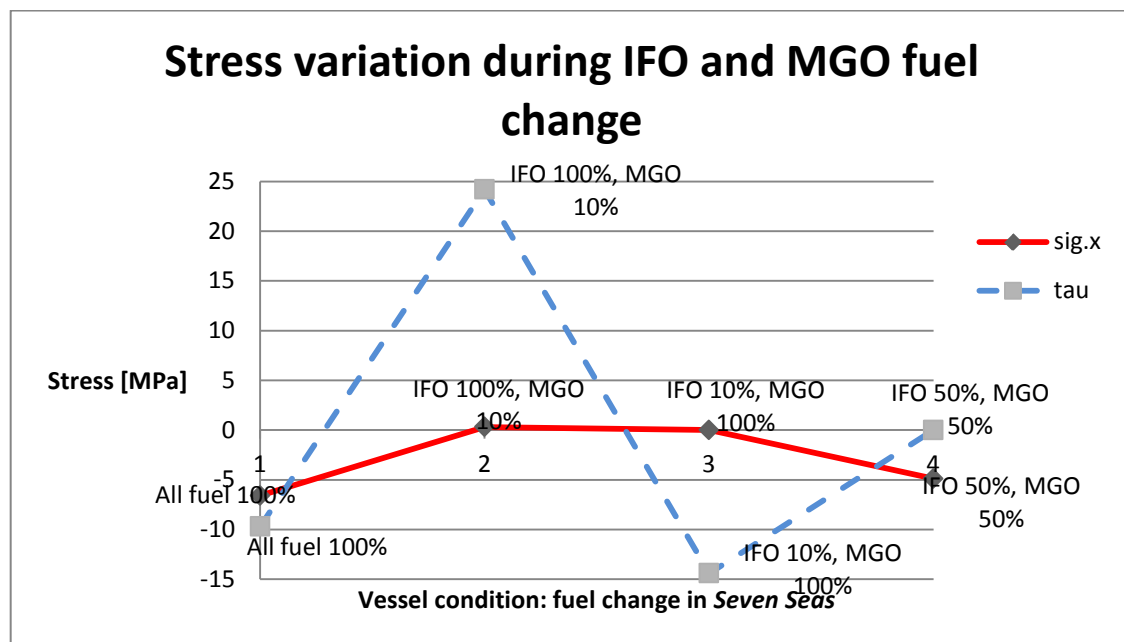

Figure 3-14: Variation in stresses during *Seven Seas* fuel change.

*Seven Seas*' load case implemented in NAPA clearly shows that structures on deck also influence the global bending stress and shear stresses on the plate. The loading condition implemented in NAPA is a light condition with a 400-ton deck load at aft and a 200-ton deck load at frame 72. By comparing *Seven Seas*' NAPA load condition with *Seven Seas*' light condition from the Stability Booklet, it can be clearly seen that the global stresses on the plate change with additional deck loads. A vessel's light condition is a theoretical condition and does not represent an operational condition (as stated in Section 2.2.1). The condition is considered because it gives larger stresses at the side plate. The large stresses arise because there are no ballast and fuel, combined with a structure intentionally placed at aft to create global bending moment around amidships, in addition to the protruding structure at frame 72, which creates global shear forces.

Chapter 4 evaluates the side plate. When including all stresses in 'Design case 2' (Section 4.2.4), three load cases and the corresponding stresses are considered. The three cases are the DNV approach in sagging and in hogging condition (load combination 2), and the NAPA loading condition.

The two conditions are selected because:

- The DNV approach gives the largest stresses on the plate; it is included because the stresses represent values for a 20-year return period and are considered as the design stresses.
- The stresses on the plate arising from the NAPA loading case are considered as stresses which are likely to occur.

## **4 AN EVALUATION OF THE PLATE CAPACITY**

### **4.1 THE APPROACH METHOD**

Shipyard companies commonly specify the vessel's permissible payload on deck in the Stability Booklet, often given in tons/m<sup>2</sup>. If the weight load from the structure on deck has a good margin with respect to the permissible load, performing a capacity check is most likely unnecessary. However, if the weight of the structure is somewhat close to the permissible load, it is necessary to perform a plate capacity check.

This chapter will carry out a capacity check of a stiffened plate mainly with respect to DNV's and NORSOK's criteria for plate thickness, plate buckling, plate yield, stiffener yield and stiffener buckling when the plate is subjected to separate and combined 'global' and 'local' loads. After this chapter it should be clarified whether the 'global' loads may have a significant impact on the capacity of the side plate located around sheer strake area.

There are many available rules, codes and guidelines for buckling and yielding design of stiffened panels in vessel structures, which are useful in quick design checks. The main rules, codes and guidelines that exist are DNV (-RP-C201, -OS-C101, etc.), NORSOK (N-003, N-004, etc.), ABS (ABS MODU Rules, ABS-126, ABS 127, ABS 130, etc.).

The selected approach for evaluating the plate capacity is by the use of the computer software 'STIPLA', which is mainly based on DNV and NORSOK standards and recommended practices [13, 14, 22].

## 4.2 RESULTS: AN EVALUATION OF THE PLATE CAPACITY

### 4.2.1 Design Basis

The stiffened plate is assumed to have the following arrangement and geometry as shown in Table 4-1 and Figure 4-1. It is not only the magnitude of the arising stresses on the plate which influence the plate's capacity but also the stiffened plate's characteristics. The stiffened plate's characteristics obviously vary for each vessel and its location. The design basis is partly based on the drawing in Appendix J. The stiffener is assumed to be a snipped flat bar with dimensions 150x15. The total length of the girder/frame ( $L_g$ ) is selected as the length from the main deck and down to the inner bottom plate. The lateral torsional buckling is selected as half of the plate width ( $L$ ). The yield strength material for both plate and stiffener are S355 and the modulus of elasticity is 210 GPa. The safety format is LRFD.

Table 4-1: Geometrical data for the side plate  
Based on [2].

<i>Geometry</i>	<i>[mm]</i>
L	1000
$L_g$	11025
t	18
s1	780
s2	780
$L_t$	500
tw	15
H	150

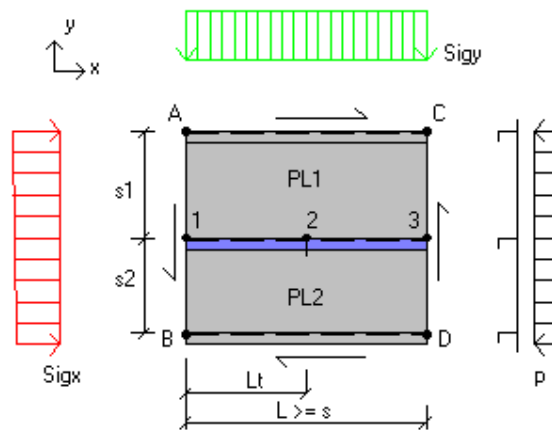

Figure 4-1: Longitudinal stiffened plate and its load combinations.  
Retrieved from Stipla. (According to definition in the nomenclature, 'sigy' should be understood as  $\sigma_z$ )

It is assumed that the load from the protruding structure on deck is a uniform distribution of stress from Point A to C, as shown in Figure 4-1. When seafastening, it is recommended that the structure be seafastened in such a manner that point loads on the plate are avoided as this might lead to a more critical load combination.



The Stability Booklet specifies the permissible deck load to be 10 tons/m<sup>2</sup>. The protruding structure on deck is assumed to be 200 tons. As we do not know the structure's load distribution on deck, it is assumed to give uniformly distributed in-plane vertical stresses ( $\sigma_y$ ) equal to 70% of the allowable design stress when only in-plane vertical stresses are considered.

Design case 1 only evaluates the vertical stresses on the plate, stresses which arise because of the structure on deck. This is the normal SS7 procedure. Iteration is performed to see how much the plate is able to withstand when only vertical stresses are working on the stiffened plate. In further studies (design case 2), it will be assumed that 70% of the allowable stress is the actual stress working.

Design case 2 includes all stresses on the plate. The vertical stress is now (as mentioned) assumed to be the value iterated in case 1 (70% allowable design stress). The two considered load conditions which give global stresses are: DNV's load combination 2 and NAPA's load case.

#### **4.2.2 STIPLA Software Application**

The plate capacity check performed by STIPLA considers the following:

- Plate buckling check (in accordance with DNV [13], Section 7.4)
- Stiffener buckling check (in accordance with DNV [13], Section 7.7)
- Plate yield check (in accordance with DNV [13] and [14]. Outerpoints A-D are inspected)
- Plate thickness check (in accordance with DNV [14], Section 5, F)
- Stiffener yield check (in accordance with DNV [13] and [14]. Point 2 is inspected)

### 4.2.3 Design Case 1

Design case 1 considers stresses on the plate solely due to the structure on deck. This means that the stresses from global vessel loads, such as bending stress, shear stress and sea pressure, are neglected. The intention is to evaluate the capacity of the stiffened plate according to normal SS7 procedure.

The stiffener capacity curve is presented in Figure 4-2, retrieved from results in STIPLA.

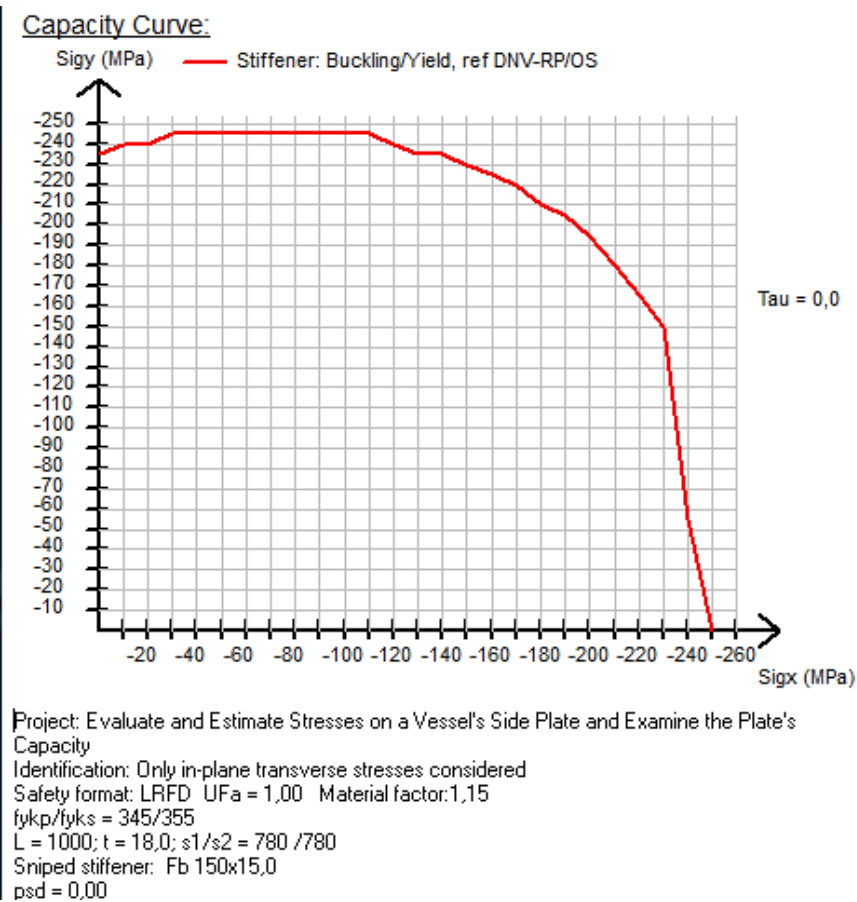

Figure 4-2: Design case 1; buckling and yield capacity curve for stiffener.

**4.2.3.1 How much in-plane vertical compression stresses ( $\sigma_y$ ) can the plate withstands?**

Figure 4-3 shows the arrangement of the stiffened plate and the direction of the in-plane vertical compression stress. Table 4-2 presents the buckling, yield and plate thickness interaction ratios for the plate and the stiffener when the plate is subjected to 203 MPa in-plane compressions.

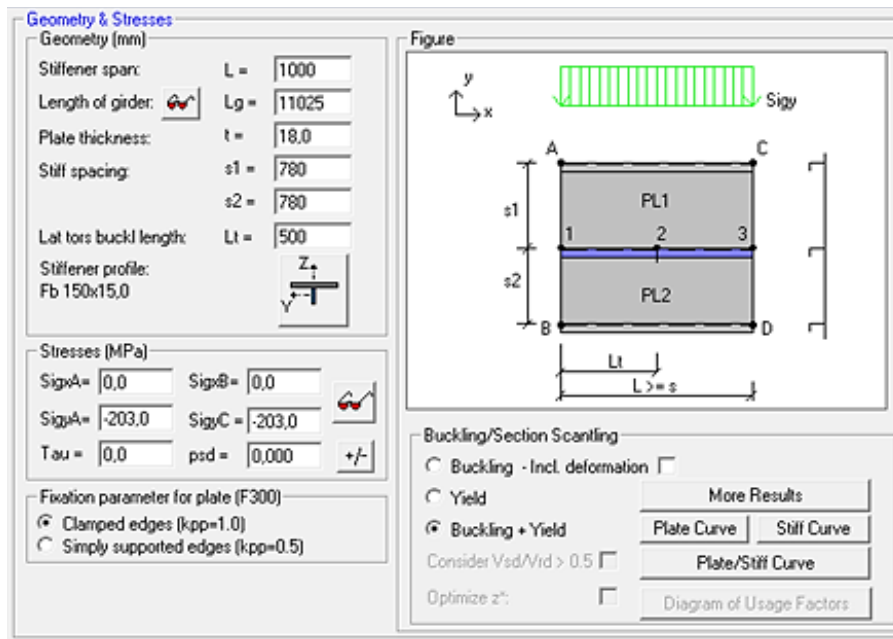

Figure 4-3: Plate geometry and the allowable vertical stress on stiffened plate.

Table 4-2: Plate capacity results, design case 1; -203MPa allowable stress.

Description	Reference	Interaction ratio	Limit value
Plate buckling check	DNV-RP-C201, Ch. 7.4	1.00	< 1.00
Stiffener buckling check	DNV-RP-C201, Eq. 7.59	0.24	< 1.00
Plate yield check	Checked at Point A-D	0.68	< 1.00
Plate thickness check	DNV-OS-C101, Sec. 5, F200	0.32	< 1.00
Stiffener yield check	Checked at point 2	0.68	< 1.00

Preliminary conclusions:

The allowable in-plate vertical compression stress is -203 MPa. Table 4-2 indicates that the first failure mode will be plate buckling.

**4.2.3.2 Plate subjected to 70% of the allowable design stress; 142 MPa in-plane vertical compression ( $\sigma_y$ )**

Figure 4-4 shows the arrangement of the stiffened plate and the direction of in-plane vertical compression stress. Table 4-3 presents the buckling, yield and plate thickness interaction ratios for the plate and the stiffener when the plate is subjected to 142 MPa in-plane compressions.

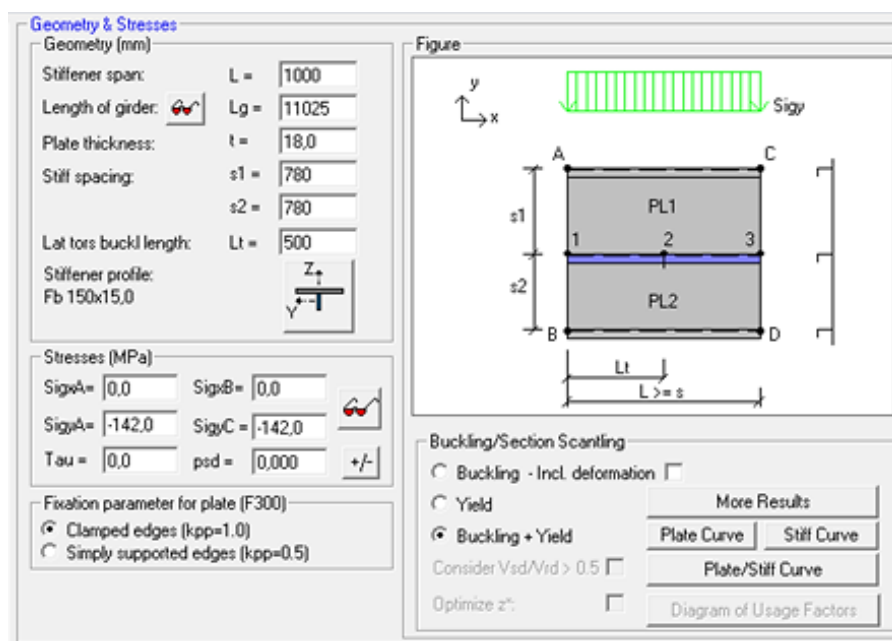

Figure 4-4: 70% allowable in-plane vertical stress on stiffened plate.

Table 4-3: Plate capacity results, design case 1; 70% allowable stress.

Description	Reference	Interaction ratio	Limit value
Plate buckling check	DNV-RP-C201, Ch. 7.4	0.70	< 1.00
Stiffener buckling check	DNV-RP-C201, Eq. 7.59	0.17	< 1.00
Plate yield check	Checked at Point A-D	0.47	< 1.00
Plate thickness check	DNV-OS-C101, Sec. 5, F200	0.32	< 1.00
Stiffener yield check	Checked at point 2	0.47	< 1.00

Preliminary conclusions:

The interaction results in Table 4-3 coincide with those of Table 4-2. The interaction ratios for plate buckling, stiffener buckling, plate yield and stiffener yield have decreased down to 70%. The interaction ratio for plate thickness is the same, as the plate thickness is constant and there are still only the in-plane vertical compression stresses working.

### 4.2.4 Design Case 2

Design case 2 considers all stresses and pressure on the plate. This means that no ‘global’ vessel loads are neglected (except ballast pressure).

#### 4.2.4.1 Sagging condition

##### Case 2.1: Design load combination 2 ( from DNV approach).

Figure 4-5 shows the in-plane vertical compression stress ( $\sigma_y$ ) and in-plane longitudinal compression stress ( $\sigma_x$ ) that arise from the *Seven Seas* DNV design bending moment, the shear stresses ( $\tau$ ) that arise from the *Seven Seas* DNV design shear forces, and the DNV design sea pressure. Table 4-4 presents the buckling, yield and plate thickness interaction ratios, and Figure 4-6 shows the plate and stiffener capacity curve.

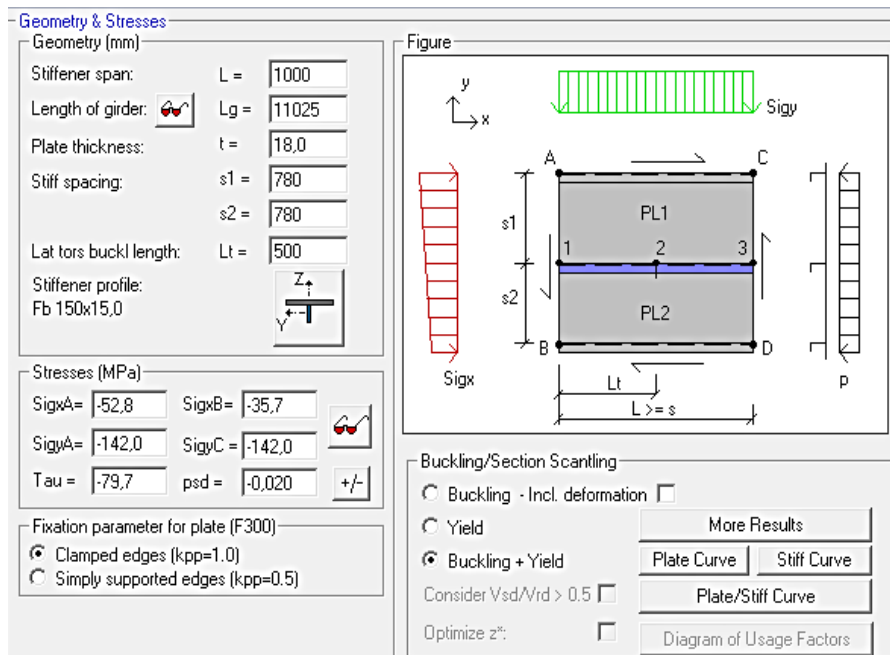

Figure 4-5: Stresses and stiffened plate arrangement for case 2.1

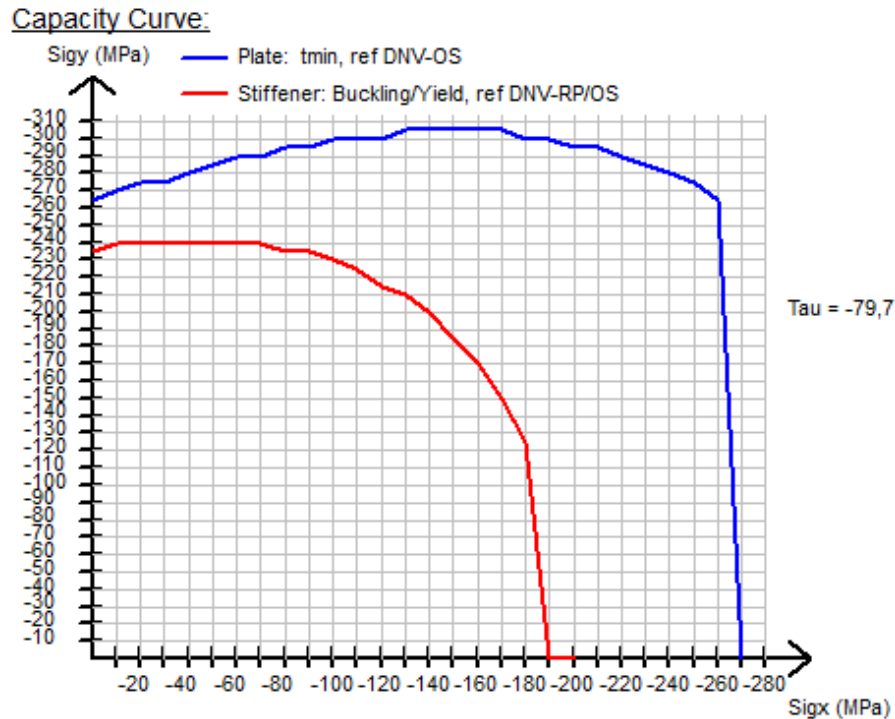

Figure 4-6: Design case 2.1; Buckling and yield capacity curve for stiffener and plate.

Table 4-4: Plate capacity results, design case 2.1

Description	Reference	Interaction ratio	Limit value
Plate buckling check	DNV-RP-C201, Ch. 7.4	<b>0.76</b>	< 1.00
Stiffener buckling check	DNV-RP-C201, Eq. 7.59	<b>0.55</b>	< 1.00
Plate yield check	Checked at Point A-D	<b>0.63</b>	< 1.00
Plate thickness check	DNV-OS-C101, Sec. 5, F200	<b>0.21</b>	< 1.00
Stiffener yield check	Checked at point 2	<b>0.62</b>	< 1.00

Preliminary conclusions:

The plate buckling interaction ratio in Table 4-4 indicates that the plate buckling increases by 8% of the limit value. The longitudinal bending stress does not significantly influence the plate buckling. It is the author's understanding that the shear stress might be the reason for the 8% increment. The longitudinal stiffener withstands most of the longitudinal bending stress which arises from the global vessel bending moment. Table 4-4 indicates that the interaction ratio for stiffener buckling increases by 38%. The table also indicates that interaction ratio for plate yield and stiffener yield increase by 16% and 15% respectively. The interaction ratio for plate thickness decreases by 10% because von Mises stress is accounted for (combination of stress in multiple directions).

#### 4.2.4.2 Hogging condition

#### Case 2.2: Design load combination 2 (from DNV approach)

Figure 4-7 shows the in-plane vertical compression stress ( $\sigma_y$ ) and in-plane longitudinal tension stress ( $\sigma_x$ ) that arise from the *Seven Seas* DNV design bending moment, the shear stresses ( $\tau$ ) that arise from the *Seven Seas* DNV design shear forces, and the DNV design sea pressure. Table 4-5 presents the buckling, yield and plate thickness interaction ratios, and Figure 4-8 shows the plate and stiffener capacity curve.

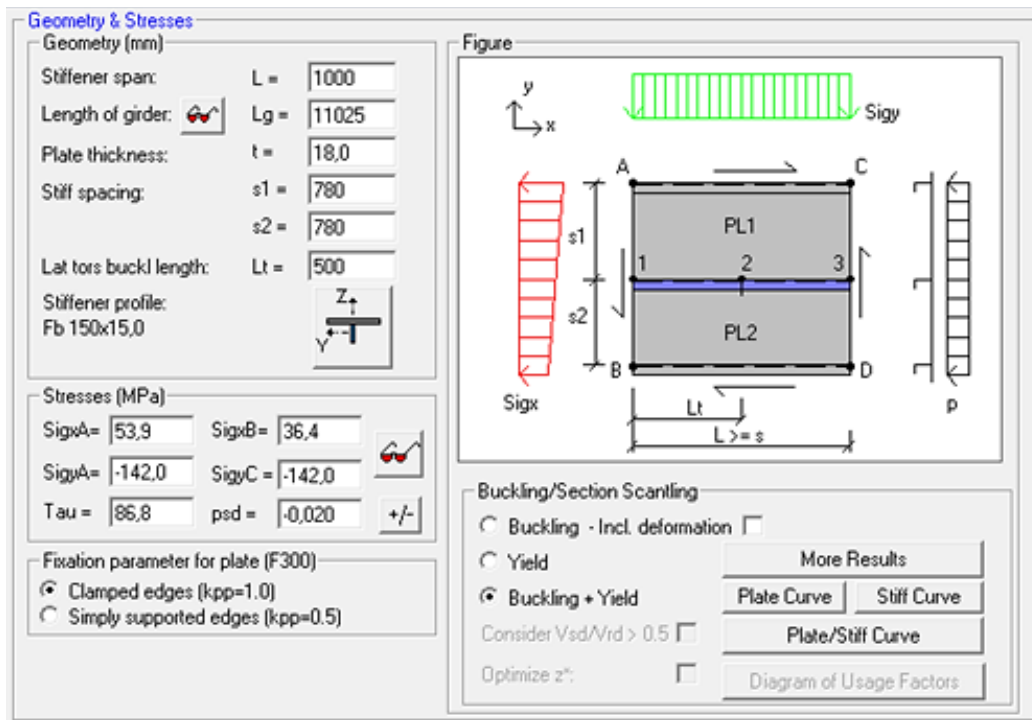

Figure 4-7: Stresses and stiffened plate arrangement for case 2.2

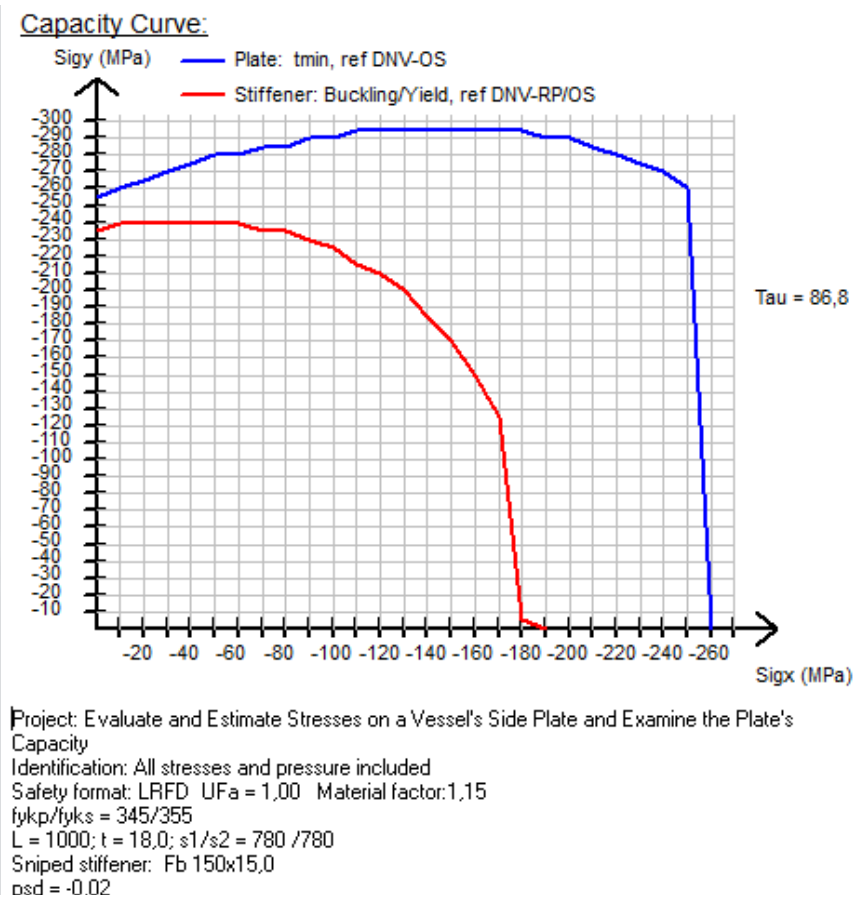

Figure 4-8: Design case 2.2; Buckling and yield capacity curve for stiffener and plate.

Table 4-5: Plate capacity results, design case 2.2.

Description	Reference	Interaction ratio	Limit value
Plate buckling check	DNV-RP-C201, Ch. 7.4	<b>0.78</b>	< 1.00
Stiffener buckling check	DNV-RP-C201, Eq. 7.59	<b>0.48</b>	< 1.00
Plate yield check	Checked at Point A-D	<b>0.77</b>	< 1.00
Plate thickness check	DNV-OS-C101, Sec. 5, F200	<b>0.26</b>	< 1.00
Stiffener yield check	Checked at point 2	<b>0.75</b>	< 1.00

Preliminary conclusions:

The plate buckling interaction ratio in Table 4-5 indicates that the plate buckling increases by 8% of the limit value. The results in the table indicate that the interaction ratio for stiffener buckling increases by 31% of the limit value. The interaction ratio for plate yield and stiffener yield increases by 30% and 28% respectively. Also, the plate thickness decreases by 6%.



**4.2.4.3 Design case 2.3: Loading condition from Seven Seas NAPA software. Still-water light ship condition with 400 tons deck load at aft. and 200 tons structure on deck located at webframe 72.**

Figure 4-9 shows the in-plane vertical compression stress ( $\sigma_y$ ) and in-plane longitudinal compression stress ( $\sigma_x$ ) that arise from the *Seven Seas* NAPA bending moments, the shear stresses ( $\tau$ ) that arise from the *Seven Seas* NAPA shear forces, and the DNV design sea pressure. Table 4-6 presents the buckling, yield and plate thickness interaction ratios, and Figure 4-10 shows the plate and stiffener capacity curve.

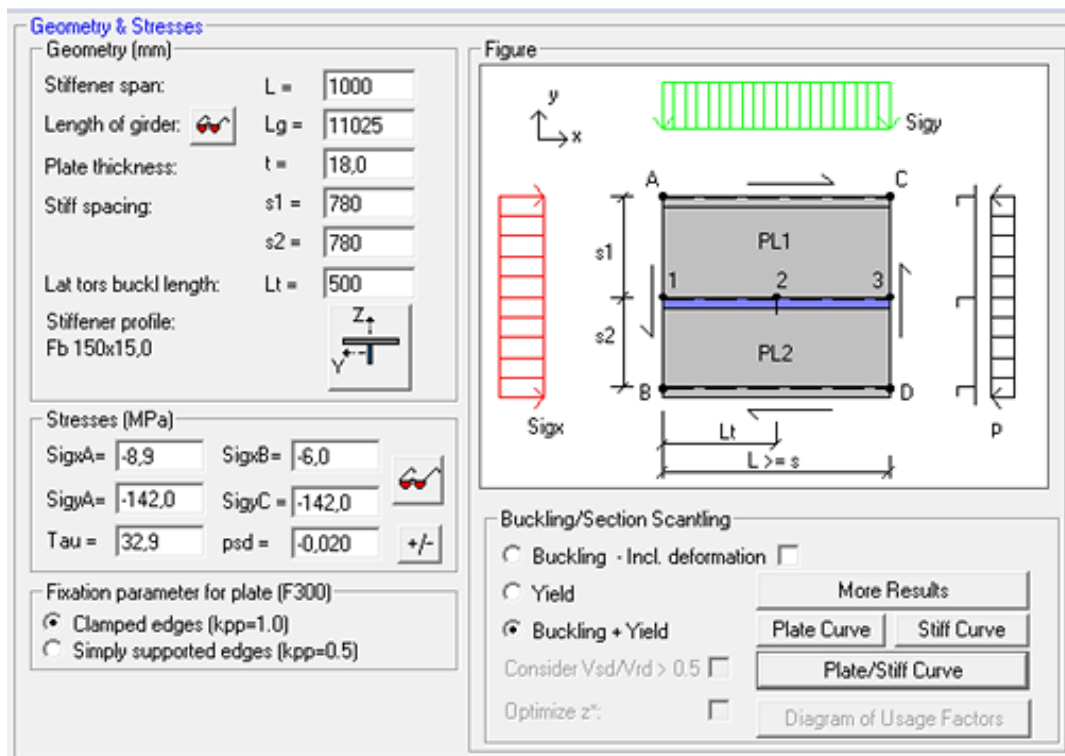
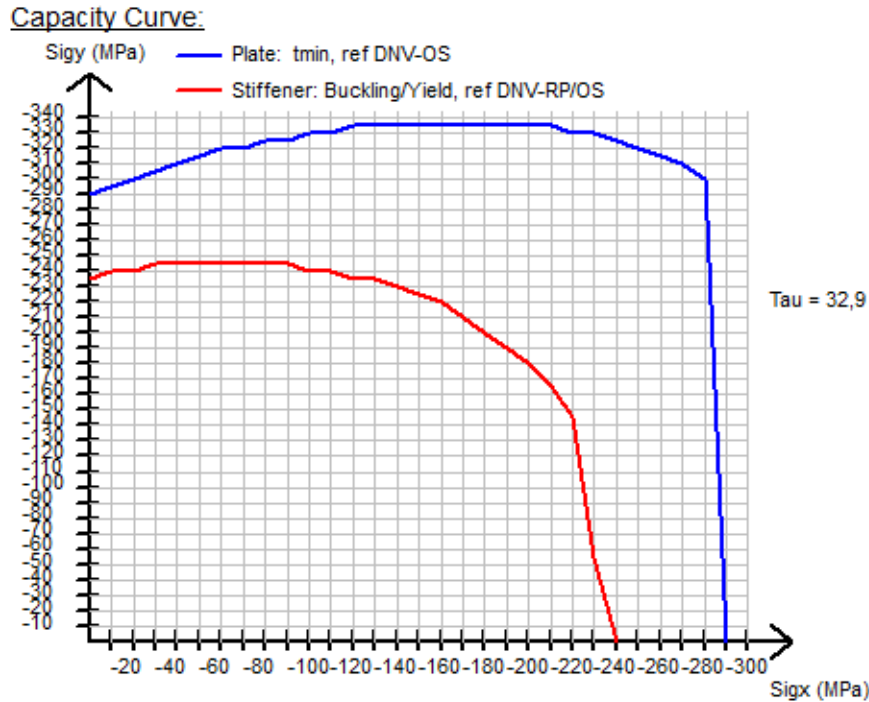

Figure 4-9: Stresses and stiffened plate arrangement for NAPA load case.



Project: Evaluate and Estimate Stresses on a Vessel's Side Plate and Examine the Plate's Capacity  
 Identification: Load combination 2, sagging condition  
 Safety format: LRFD UFa = 1,00 Material factor: 1,15  
 fykp/fyks = 345/355  
 L = 1000; t = 18,0; s1/s2 = 780 /780  
 Sniped stiffener: Fb 150x15,0  
 psd = -0,02

Figure 4-10: Design case 2.3; Buckling and yield capacity curve for stiffener and plate.

Table 4-6: Results design case 2.3, from NAPA

Description	Reference	Interaction ratio	Limit value
Plate buckling check	DNV-RP-C201, Ch. 7.4	0.71	< 1.00
Stiffener buckling check	DNV-RP-C201, Eq. 7.59	0.28	< 1.00
Plate yield check	Checked at Point A-D	0.50	< 1.00
Plate thickness check	DNV-OS-C101, Sec. 5, F200	0.18	< 1.00
Stiffener yield check	Checked at point 2	0.50	< 1.00

Preliminary conclusions:

The plate buckling interaction ratio in Table 4-6 indicates that the plate buckling increases by 1% of the limit value. The interaction ratio for stiffener buckling value increases by 11%, the plate and stiffener yield value increases by 3%, and the plate thickness value increases by 14%.

### 4.3 SUMMARY

The increased global stresses on the plate obviously do influence the plate's capacity. Firstly it should be mentioned that the stiffened plate failure modes greatly depend on the stiffened plate arrangement. It has been assumed that a large supply vessel is longitudinally stiffened at the plate. If the plate was vertically stiffened, the plate would be able to withstand more vertical stresses (stresses from a protruding structure), but the longitudinal stresses from the vessel's bending moments and shear stress could cause instant failure in the plate if it were not longitudinally stiffened. According to the author's understanding, the stiffeners are in the longitudinal direction because they are some of the important elements that withstand the global longitudinal stresses and shear stresses in the stiffened plate (ref. Section 2.2.2).

Three *Seven Seas* loading conditions were evaluated:

- DNV load combination 2, in sagging condition (still-water condition combined with seagoing condition).
- DNV load combination 2, in hogging condition (still-water condition combined with seagoing condition)
- NAPA load condition (*Seven Seas* light condition with 400-ton deck load at aft and 200-ton structure on deck located at webframe 72)

#### **Only stresses from the protruding structure are included**

This is the normal SS7 procedure and considers only the stresses from the protruding structure on deck. The selected vertical stress is 70% of the allowable stress when only the protruding structure on deck is considered.

According to the results, the critical failure mode from the protruding structure on deck is the plate buckling. The remaining failure modes are quite satisfactory as they all have interaction ratios below 0.5 (50% of capacity)

#### **DNV load combinations**

When including the global stresses on the plate, the interaction ratio for plate buckling only increases by 0.08 (8%). The 8% value is somewhat small, but the reason for this is that the plate will buckle in the vertical direction. The global shear stress is the main contributor to this 8% increase.

The global stresses have a significant influence on stiffener buckling, stiffener yield and plate yield. However, these interaction ratios are all below 0.5 when only the stresses from the protruding structure are included. This means that for our stiffened plate, the global stresses have to increase the interaction ratios by 50% or more to

obtain failures in these three modes. By including the ‘DNV stresses’ the failure modes – plate yield, stiffener yield and buckling – increase by approximately 30% of the interaction limit value. The stresses arising in the DNV load case are considered as occurring in a 20-year return period; thus these three failures should not be a problem under normal weather conditions.

**NAPA load condition: still-water light ship condition with a 400 ton structure at aft. and a 200 ton at webframe 72.**

The NAPA load case is considered as the most probable stress scenario from the three conditions.

According to the results, by including the global stresses on the plate, the interaction ratio for plate buckling only increases by 0.01 (1%). The reason for this small value is that the plate will buckle with respect to the vertical direction and in this case the global shear stresses are not large.

As before, the interaction ratios for stiffener buckling, stiffener yield and plate yield are all below 0.5 when only the stresses from the protruding structure are included. By including the global stresses, the stiffener buckling value increased by 11% and the plate and stiffener yield value increased by 3%. The plate thickness value increased by 14%. Thus, these failure modes should not be a problem under a light condition with a 400-ton deck load at aft and a 200-ton deck load at webframe considered.

In this loading case and with this specific plate, the global stresses do not significantly influence the critical mode: plate buckling. To obtain a failure mode for this stiffened plate under this NAPA load condition, it would be necessary to increase the weight of the protruding structure and its corresponding vertical in-plane stresses up to 90% of the allowable stress or higher.

## 5 DISCUSSION

### 5.1 THE ESTIMATION OF STRESSES

Questions that should be raised are:

- Are the stresses accurate and realistic?
- What assumptions have been made and how might they influence the results?
- Could the approaches in the appendices be carried out in an easier way – any adjustments?

#### **Are the stresses accurate and realistic?**

The estimated stresses do give an indication of the real stresses that might occur in the given vessel loading condition, but they are not accurate. There are many factors which contribute towards realistic values. To obtain the most authentic values in the simplified approach, it is important to strive for as exact values as possible concerning these three aspects:

- Location of neutral axis
- The values for moment of inertia
- The vessel's bending moments and shear forces (i.e. these must be found by NAPA or AutoHydro so that the true weight distribution, buoyancy distribution, and the weather conditions are included).

Reference [6] states that the equation for longitudinal stress (Eq. {3.12}), complies quite well with experiments and should therefore give a good indication. However, the equation for shear stress (Eq. {3.13}) is somewhat uncertain. The problem with shear stress is that the webframe is quite complex and there are several elements that withstand the shear force. In Eq. {3.13} the thickness of the webframe at a specified location needs to be determined. The problem is that with a multi-cell section, a statically indeterminate problem follows. Solving this statically indeterminate problem requires detailed data and complex calculations by integrating the section. To avoid this complex approach some conservative DNV rules are selected. The thickness is selected by DNV's [11] minimum required thickness for the section at the shear strake. Therefore, the shear stress at the shear strake is not considered as accurate but is considered to give an idea of how much it can be.

#### **What assumptions have been made and how might they influence the results?**

Many assumptions have been made, and some of these cannot be changed when we perform this simplified approach. However, it is important to remember that Eqs. {3.12} and {3.13} assume that all elements have the same modulus of elasticity. This assumption might lead to small changes in the stresses. If desired, these changes can easily be included by the approach presented in [8].

## **Adjustment of the approach taken in Appendices**

The author has gained a great amount of knowledge throughout the process, and throughout the process new ideas and approaches have appeared. The numerical approach for finding DNV's design bending moment and shear stresses, the neutral axis and moment of inertia are quite time-consuming and, after performing the calculations, the Nauticus Hull software was discovered. The software will be a faster approach for finding these values.

## **5.2 THE EVALUATION OF PLATE CAPACITY**

An important question to be raised is:

- How do the characteristics of stiffened plate influence the capacity?
- How does the load distribution on the plate influence the capacity?

### **Importance of the plate's characteristics**

Not only do the arising stresses determine the plate capacity, but the characteristics of the stiffened plate also have an influence. The stiffeners at the plate have a large effect on the plate's capacity. In this thesis the stiffened plate is assumed to be longitudinally stiffened, and it will in most cases be longitudinally stiffened in large supply vessels. Not only does the direction of the stiffener have an influence on the plate's capacity, but also the assumed dimensions of the stiffeners and the spacing of the stiffeners. The plate thickness, width and height also contribute to the total capacity, as do the boundary conditions.

The plate evaluated is based on the drawings and with some additional assumptions. The author wishes to emphasize that the capacity result is only valid for this specific plate and the global stresses might have a larger impact on a plate with smaller stiffeners, larger spacing between the stiffeners or a thinner plate.

### **The distribution of the vertical load from the protruding structure**

The load on the plate from the structure on deck will probably not be uniformly distributed throughout the length. The loads will appear as point loads on the plate and this might cause a more critical load situation on the plate.

### **5.3 THE INFLUENCE OF GLOBAL STRESSES ON THE EVALUATED SIDE PLATE**

The results in Section 4.2 indicated that the stresses from the structure on deck cause the plate buckling capacity to decrease considerably. The global stresses do influence the plate capacity but not all the global stresses contribute to plate buckling failure mode, which is considered as critical when a structure is on deck. The interaction ratio for plate buckling changes rapidly with stresses from the structure on deck and from the global shear stresses. The stiffener yield, stiffener buckling and plate yield change rapidly with respect to all global stresses.

#### **DNV's load conditions**

With regard to the DNV stresses (approximately 20-year return period), design still-water condition is combined with design seagoing condition, approximately 89% of allowable vertical stress for this specific plate will cause plate buckling failure.

#### **NAPA load condition: still-water light ship condition with a 400 ton structure at aft. and a 200 ton at webframe 72.**

To obtain a failure mode for this plate, it would be necessary to increase the weight of the protruding structure and its corresponding vertical stresses and global shear. Increasing the weight of the structure on deck will correspondingly increase both the global shear stress and the local vertical stress. How much the global shear stress increases by adding more weight needs to be evaluated by the use of NAPA or AutoHydro and then implementing Eq. {3.13}. If it is assumed that we do have a 70% allowable in-plane vertical stress, global shear stress equal to approximately 142 MPa would cause the limit for plate buckling failure. Also, it is important to remember that the shear stress (and longitudinal stress) also change the interaction ratio for stiffener buckling, stiffener yield and plate yield.

## 6 CONCLUSION

The study has established a simplified approach for estimating the stresses on a vessels side plate. The main steps to estimate these in-planes and out of plane stresses systematically follows the steps in Figure 6-1. The main steps are;

- Estimate bending moment and shear force diagrams for the selected vessel by applying AutoHydro or requesting longitudinal results from the vessels crew. The vessels' loading conditions and wave conditions should be included in the programs AutoHydro or NAPA.
- Access vessel drawings and determine dimensional properties of all elements that contribute to the longitudinal strength at the selected section.
- Estimate the moment of inertia and neutral axis of the section by parallel axis theorem presented in Appendix D or use the software program Nauticus hull.
- Apply Equations {3.12} and {3.13} to obtain an estimation of the stresses.

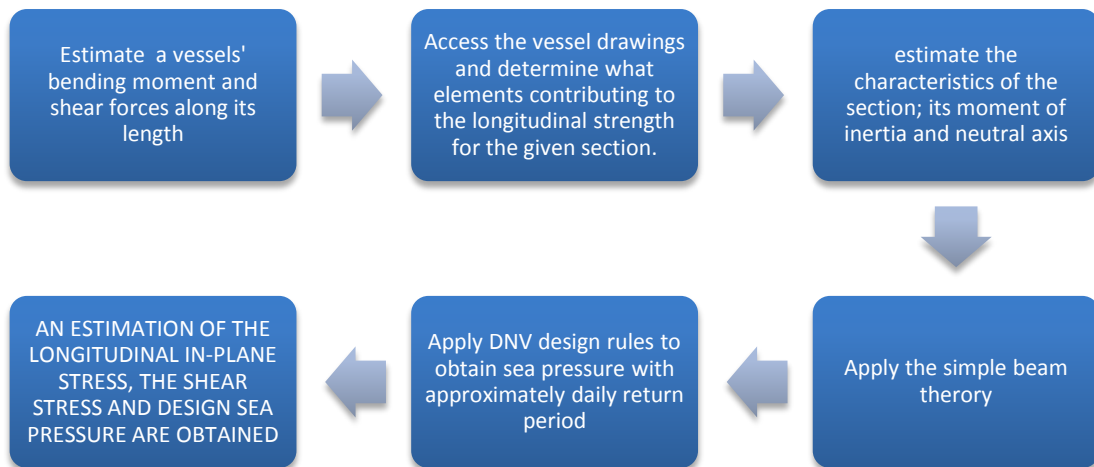

Figure 6-1: The main steps for determine the stresses arising from a vessels global loads

The study show that stresses which arises from the vessels global loads influences all failure modes on a longitudinally stiffened plate at the sheer strake area. Table 6-1 shows the study results for the side plate at sheer strake at frame 72 for the *Seven Seas* under a still-water light ship loading condition with an additional 400 tons deck load at aft. and a 200 deck load at frame 72. Table 6-2 shows the study results for the side plate when DNV design rules for a vessels' global bending moment and shear force are accessed, these stresses are considered as stresses that occur under a 20 years return period.



**Table 6-1: Stresses at the upmost point on plate due to *Seven Seas* loading condition: still-water light ship condition with 400 tons at aft and 200 tons structure above the plate on main deck.**

<b>Type of stress</b>	<b>The stress occur due to</b>	<b>The stress value</b>
Longitudinal in-plane stress	The <i>Seven Seas</i> global bending moment	-8.9MPa
Shear stress	The <i>Seven Seas</i> global shear force	32.9MPa
Sea pressure	The <i>Seven Seas</i> design rule sea pressure	-0.02MPa

**Table 6-2: Stresses at the upmost point on plate due to *Seven Seas* loading condition: DNV design rule bending moment and shear force distribution under sagging condition.**

<b>Type of stress</b>	<b>The stress occur due to</b>	<b>The stress value</b>
Longitudinal in-plane stress	The <i>Seven Seas</i> design rule bending moment	-52.8MPa
Shear stress	The <i>Seven Seas</i> design rule shear force	-79.7MPa
Sea pressure	The <i>Seven Seas</i> design rule sea pressure	-0.02MPa

Then one shall implement these stresses on a stiffened side plate, a stiffened side plate with characteristics mainly based on the vessel drawings. The modulus of elasticity for the plate, the direction of the stiffeners, the spacing between the stiffeners, the thickness of the plate and the length of the girders at the side structure are all selected by studying the drawings. It is assumed that the stresses from the structure on the deck is large and is approximately 70% of the allowable stress. Table 6-3 shows how the interaction ratios for the 5 most common failure modes changes before and after including the stresses that arise from the *Seven Seas* NAPA condition: still-water light ship condition with a 400 tons deck load at aft and a 200 tons structure above the plate on main deck. Table 6-4 shows how the interaction ratios for the 5 most common failure modes changes before and after including the stresses that arise from the *Seven Seas* design rule bending moment and shear force.

Table 6-3: The influence of global vessel loads on a specific side plate at sheer strake under *Seven Seas* still-water light ship condition with a 400 tons structure on deck and a 200 tons structure above the plate on main deck. Design sea pressure also included.

Failure mode	Interaction ratio before the global stresses on plate are included	Interaction ratio when the global stresses are included	Increase/decrease of interaction ratio	Interaction limit value
Plate buckling	0.70	0.71	+0.01	1.00
Stiffener buckling	0.17	0.28	+0.11	1.00
Plate yield	0.47	0.50	+0.03	1.00
Plate thickness	0.32	0.18	-0.14	1.00
Stiffener yield	0.47	0.50	0.03	1.00

Table 6-4: The influence of global vessel loads on a specific plate at sheer strake under *Seven Seas* design rule bending moment, shear force and sea pressure.

Failure mode	Interaction ratio before the global stresses on plate are included	Interaction ratio when the global stresses are included	Increase/decrease of interaction ratio	Interaction limit value
Plate buckling	0.70	0.76	+0.06	1.00
Stiffener buckling	0.17	0.55	+0.38	1.00
Plate yield	0.47	0.63	+0.16	1.00
Plate thickness	0.32	0.21	-0.11	1.00
Stiffener yield	0.47	0.62	+0.15	1.00

The results in Table 6-3 indicate that the stresses that arise from the global loads for this specific case influence on the plate capacity in small extent. The results in Table 6-4 indicate that the stresses arising under an approximately 20 years return period influence the plate capacity significantly. The studies in this thesis show that the shear stress increases the possibility for plate buckling, stiffener buckling, plate yield and stiffener yield. The study also shows that longitudinal in-plane stress increases the possibility for stiffener buckling.

To determine if Subsea 7 should include the stresses that arise from the vessels global loads on frequently capacity checks, more loading conditions of vessels should be conducted to gain a larger perspective of possible stress scenarios.

## 7 FURTHER STUDIES

A simplified approach for estimating the global stresses on plate is obtained in this study. This estimation should be verified by computer software that uses FEM, an example of software that can be used is Sesam HydroD.

The study only considers one plate arrangement and stresses at one section for the vessel *Seven Seas* with additional assumptions. More case studies should be performed to gain a deeper perspective, as the stiffened plate arrangements will change for other vessels and stresses arising may be higher for a specific vessel and a specific plate.

Also, the study has not included the effect of stresses from different wave conditions. The stresses should be found in different wave conditions. This effect can be studied by FEA in computer software or it can be studied by using the simplified approach. For the simplified approach, the requirement is that the vessel is generated in the computer software AutoHydro or that the vessel's crew provides the results from the integrating loading program.

Last but not least, the torsional effect in the vessel should be investigated as it may have an influence on the stresses at plate if large structures are placed starboard or portside. at aft. and forward.

## 8 REFERENCES

- [1] Professor Gudmestad, O., T. (2012). Lecture notes in *OFF600 Marine Operations*. University of Stavanger, Norway.
- [2] IHC Merwede (2009). *Stability Booklet, Flex-Lay Construction Vessel*. Yard number 710, IMO No. 9 38 47 60. The Netherlands.
- [3] Dokkum, K.V. (2003). *Ship Knowledge, A Modern Encyclopedia*. DOKMAR, The Netherlands.
- [4] Thorat, P., H. and Saha, M. (2013). Conversations and discussions at the Subsea 7 Forus office. Stavanger, Norway.
- [5] Mohammed, A., K. (2001). *Nonlinear shell finite elements for ultimate strength and collapse analysis of ship structures*. The Department of Marine Structures, Faculty of Marine Technology, Norwegian University of Science and Technology. Trondheim, Norway.
- [6] Mansour, A. and Liu, D. (2008). *Strength of Ships and Ocean Structures*. The Principal of Naval Architecture Series, Society of Naval Architects and Marine Engineers, SNAME.
- [7] Odland, J. (2013). Conversation and discussion with Professor Jonas Odland, 29 April 2013 at the University of Stavanger, Stavanger, Norway.
- [8] Miller, P.H., Stettler, J.W. (2009). *EN358 Ship Structures, Notes for an Undergraduate Course*. Naval Architecture Program, United States Naval Academy, USA.
- [9] Hughes, O.F. and Paik, J.K. (2010). *Ship Structural Analysis and Design*. The Principal of Naval Architecture Series, Society of Naval Architects and Marine Engineers, SNAME.
- [10] <http://www.marineinsight.com/misc/marine-safety/water-tight-bulkheads-on-ships-construction-and-arrangement/> (Accessed on March 2013)
- [11] DNV (2013). Rules for classification of Ships Part 3, Chapter 1. *Hull Structural Design, Ships with Length 100 Metres and Above*. Det Norske Veritas, Norway.
- [12] Paik, J.K. and Thayamballi, A.K. (2003). *Ultimate Limit State Design of Steel-Plated Structures*. Wiley, Chichester, England.
- [13] DNV (2010). Recommended Practice DNV-RP-C201. *Buckling Strength of Plates Structures*. Det Norske Veritas, Norway.
- [14] DNV (2011). Offshore Standard DNV-OS-C101. *Design of Offshore Steel Structures, General (LRFD Method)*. Det Norske Veritas, Norway.

- [15] <http://www.ivt.ntnu.no/imt/courses/tmr4205/literature/PowerPointPresentation/Plate-knekking.pdf> (Accessed on May 2013)
- [16] Salvesen, N., Tuck, E.O., Faltinsen, O. (1970). *Ship Motions and Sea Loads*. The Society of Naval Architects and Marine Engineers, New York, N.Y. 10006. No. 6.
- [17] <http://cadcam.autoship.com/cadproductsservices/autohydro/autohydro.htm> (Accessed on June 2013)
- [18] DNV (2002). Recommended Practice, DNV-RP-C102. *Structural Design of Offshore Ships*. Det Norske Veritas, Norway.
- [19] DNV (2012). Offshore Standard, DNV-OS-C102. *Structural Design of Offshore Ships*. Det Norske Veritas, Norway.
- [20] Beer, F.P., Johnston, Jr., E.R., DeWolf, J.T., Mazurek, D.F. (2009). *Mechanics of Materials Fifth Edition (SI Units)*. McGraw-Hill Companies, New York.
- [21] DNV (2007). Recommended Practice DNV-RP-C101. *Allowable Thickness Diminution for Hull Structures of Offshore Ships*. Det Norske Veritas, Norway.
- [22] NORSOK (2013). NORSOK Standard N-004. *Design of Steel Structures*. Lysaker, Norway

## LIST OF APPENDICES

- Appendix A Calculate longitudinal design bending moments and design shear forces, in accordance with DNV approach
- Appendix B *Seven Seas* Stability Booklet
- Appendix C Longitudinal stability diagram retrieved from *Seven Seas*' crew
- Appendix D Calculated neutral axis and moment of inertia for webframe
- Appendix E Estimated stresses on side plate.
- Appendix F Estimated sea pressure on plate.
- Appendix G Performed plate capacity check.
- Appendix H Holland Profile table
- Appendix J Drawings of the vessel *Seven Seas*.

**APPENDIX A - LONGITUDINAL DESIGN BENDING  
MOMENTS AND DESIGN SHEAR FORCES**

## APPENDIX A

This appendix estimates the design bending moments and shear forces along *Seven Seas* length with accordance to the DNV approach which is presented in Section 3.2.2.

### **A.1: References**

/1/ DNV (2013). Rules for Classification of Ships, Part 3 Chapter 1. *Hull Structural Design, Ships with Length 100 Metres and Above*. Det Norske Veritas, Norway.

/2/ IHC Merwede (2009). *Stability Booklet, Flex-lay Construction Vessel*. Yard number 710, IMO No. 9 38 47 60. The Netherlands

/3/ DNV (2007). Recommended Practice, DNV-RP-C101. *Allowable Thickness Diminution for Hull Structures of Offshore Ships*. Det Norske Veritas, Norway.

### **A.2: Vessel Data**

#### **A.2.1 Vessel geometry /2/**

Length between perpendiculars ( $L_p$ ):  $L_p := 142.08 \text{ m}$

Greatest molded breadth of *Seven Seas* (B):  $B := 28.4 \text{ m}$

Mean molded summer draught ( $T_{\text{mean}}$ ):  $T_{\text{mean}} := 7.5 \text{ m}$

Vessel depth (D):  $D := 12.5 \text{ m}$

#### **A.2.2: Parameters from DNV /1/ and *Seven Seas* Stability Booklet /2/**

Wave load coefficient ( $C_{WU}$ ): 
$$C_{WU} = 10.75 - \left[ \frac{(300 - L_p)}{100} \right]^{\frac{3}{2}} = 8.765 \text{ -}$$

Wave load coefficient ( $C_W$ ):  $C_W := C_{WU} = 8.765 \text{ -}$

Block coefficient ( $C_B$ ):  $C_B := 0.797 \text{ -}$

At sheltered areas and harbour:  $\alpha_{\text{shelt}} := 0.5 \text{ -}$

$\beta_{\text{shelt}} := 0.5 \text{ -}$

When in seagoing condition:  $\alpha_{\text{seag}} := 1.0 \text{ -}$

$\beta_{\text{seag}} := 1.0 \text{ -}$



**A.2.3: Assumptions**

- 1) - The waterline throughout the vessels length is assumed to be the same as the mean molded summer draught value.
- 2) - Block coefficient is assumed to not change throughout the vessel.

**A.3: Notation**

The values obtained from this appendix is the design(maximum) values with accordance to DNV rules. These values does not represent the real time moments, forces or stresses on a vessel while actually operating, however it is the maximum values the vessel should be designed for.

**A.4: Drawing of the Vessel Seven Seas /2/**

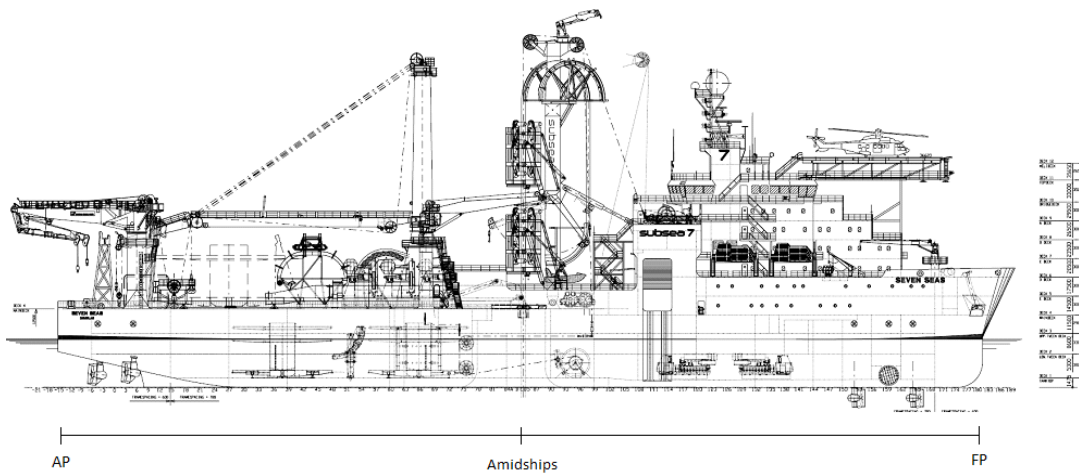

**A.5: Summary of Bending Moments and Shear Forces**

With accordance to DNV /1, 3/, bending moments and shear forces at webframe 72m from the AP are:

Max. Allowable Load Condition	Bending Moment, M [kNm]		Shear Force, Q [kN]	
	Sagging	Hogging	Sagging	Hogging
Still-water	-489000	55500	-13800	15600
Vertical wave in sheltered condition	-244100	224500	-3300	3300
Vertical wave in seagoing condition	-488200	449000	-6600	6600
Load combination 1	-928500	980900	-21100	23400
Load combination 2	-1050000	1072000	-21300	23200

**A.6: Maximum Allowable Longitudinal Bending Moment and Shear Forces /1/**

From DNV, Rules for Ships, Pt.3 Ch.1 Sec.5 /1/: The wave bending moments and shear forces are given as the design values with a probability of exceedance of 10<sup>-8</sup>.

**A.6.1: Design Still-water Bending Moments**

Equation {3.1} specify: the design still water bending moments at arbitrary positions along the length of the ship for sagging and bending should not be taken less than equation

$$M_S = k_{sm} \cdot M_{SO} \quad [\text{kNm}] \quad \text{Eq. \{3.1\}}$$

$$M_{SO\_S} := -0.065 \cdot C_{WU} \cdot L_p^2 \cdot B \cdot (C_B + 0.7) \quad \text{in [kNm] Sagging}$$

$$M_{SO\_H} := C_{WU} \cdot L_p^2 \cdot B \cdot (0.1225 - 0.015 \cdot C_B) \quad \text{in [kNm] Hogging}$$

$$M_{SO\_S} = -4.89 \times 10^5 \quad \text{kNm}$$

$$M_{SO\_H} = 5.555 \times 10^5 \quad \text{kNm}$$

Read and interpolate Figure 3-2 in Section 3.2.2 and obtain values for  $k_{sm}$ .

$k_{sm} :=$

	0
0	0.075
1	0.15
2	0.363
3	0.575
4	0.788
5	1

Sagging condition:

$$M_{S\_S} := k_{sm} \cdot M_{SO\_S} \cdot (kN \cdot m) = \begin{pmatrix} -3.667 \times 10^4 \\ -7.335 \times 10^4 \\ -1.775 \times 10^5 \\ -2.812 \times 10^5 \\ -3.853 \times 10^5 \\ -4.89 \times 10^5 \end{pmatrix} \cdot kN \cdot m \quad \text{Eq. \{3.1\}}$$

Hogging condition:

$$M_{S\_H} := k_{sm} \cdot M_{SO\_H} \cdot (kN \cdot m) = \begin{pmatrix} 4.166 \times 10^4 \\ 8.333 \times 10^4 \\ 2.017 \times 10^5 \\ 3.194 \times 10^5 \\ 4.377 \times 10^5 \\ 5.555 \times 10^5 \end{pmatrix} \cdot kN \cdot m \quad \text{Eq. \{3.1\}}$$

Design still-water bending moments over *Seven Seas* length are:

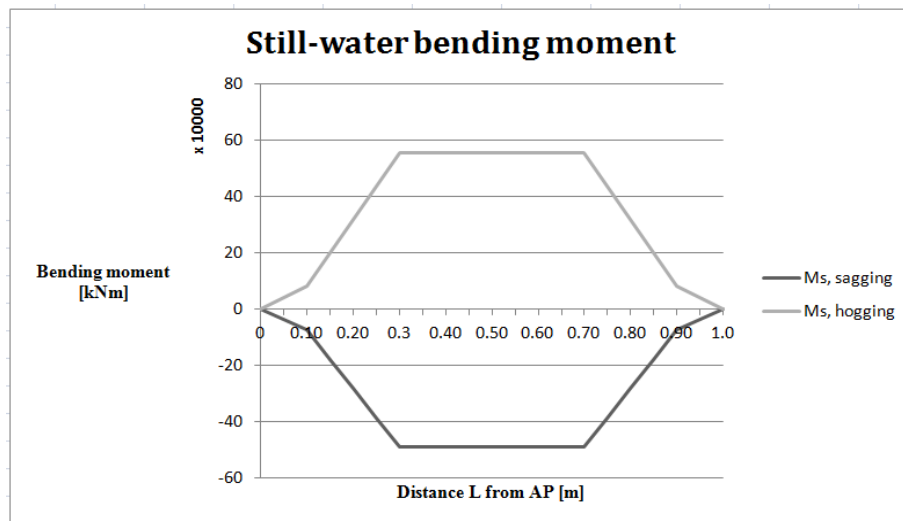

Distance from AP [m]	Ms	
	Sagging [kNm]	Hogging [kNm]
0L	0	0
0.05L	-36700	41700
0.10L	-73400	83300
0.15L	-177300	201700
0.20L	-281200	319400
0.25L	-385300	437700
0.30L	-489000	555500
0.35L	-489000	555500
0.40L	-489000	555500
0.45L	-489000	555500
0.50L (= 72m)	-489000	555500
0.55L	-489000	555500
0.60L	-489000	555500
0.65L	-489000	555500
0.70L	-489000	555500
0.75L	-385300	437700
0.80L	-281200	319400
0.85L	-177300	201700
0.90L	-73400	83300
0.95L	-36700	41700
1.0L	0	0

<-- Still-water bending moment of interest

**A.6.2: Still-water Shear Forces**

Equation {3.2} and {3.3} specify: the design still water shear forces at arbitrary positions along the length of the ship for sagging and hogging should not be taken less than

$$Q_s = k_{sq} \cdot Q_{so} \quad [\text{kN}] \quad \text{Eq. \{3.2\}}$$

Sagging: 
$$Q_{SO\_S} := 5 \cdot \left( \frac{M_{SO\_S}}{L_p} \right) = -1.721 \times 10^4 \quad \text{kN} \quad \text{Eq. \{3.3\}}$$

Hogging: 
$$Q_{SO\_H} := 5 \cdot \left( \frac{M_{SO\_H}}{L_p} \right) = 1.955 \times 10^4 \quad \text{kN} \quad \text{Eq. \{3.3\}}$$

Read and interpolate  $k_{sq}$  values in Section 3.2.2 and obtain values for  $k_{sq}$ .

$k_{sq} :=$

	0
0	0.333
1	0.666
2	1
3	0.9
4	0.8
5	0.9
6	1
7	0.666
8	0.333

Sagging condition:

Eq. {3.2}

$$Q_{S_S} := k_{sq} \cdot Q_{SO_S} (kN \cdot m) = \begin{pmatrix} -5.73 \times 10^3 \\ -1.146 \times 10^4 \\ -1.721 \times 10^4 \\ -1.549 \times 10^4 \\ -1.377 \times 10^4 \\ -1.549 \times 10^4 \\ -1.721 \times 10^4 \\ -1.146 \times 10^4 \\ -5.73 \times 10^3 \end{pmatrix} \cdot kN \cdot m$$

Hogging condition:

$$Q_{S_H} := k_{sq} \cdot Q_{SO_H} (kN \cdot m) = \begin{pmatrix} 6.51 \times 10^3 \\ 1.302 \times 10^4 \\ 1.955 \times 10^4 \\ 1.759 \times 10^4 \\ 1.564 \times 10^4 \\ 1.759 \times 10^4 \\ 1.955 \times 10^4 \\ 1.302 \times 10^4 \\ 6.51 \times 10^3 \end{pmatrix} \cdot kN \cdot m \quad \text{Eq. {3.2}}$$

The design still-water shear force over *Seven Seas* length are:

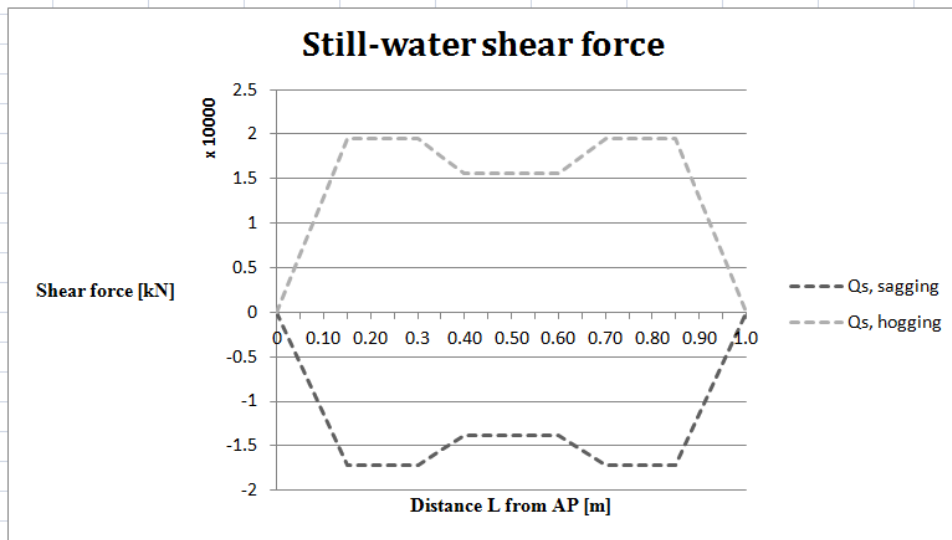

Distance from AP [m]	Qs	
	Sagging [kN]	Hogging [kN]
0L	0	0
0.05L	-5700	6500
0.10L	-11500	13000
0.15L	-17200	19600
0.20L	-17200	19600
0.25L	-17200	19600
0.30L	-17200	19600
0.35L	-15500	17600
0.40L	-13800	15600
0.45L	-13800	15600
0.50L (= 72m)	-13800	15600
0.55L	-13800	15600
0.60L	-13800	15600
0.65L	-15500	17600
0.70L	-17200	19600
0.75L	-17200	19600
0.80L	-17200	19600
0.85L	-17200	19600
0.90L	-11500	13000
0.95L	-5700	6500
1.0L	0	0

<-- Still-water shear force of interest

**A.6.3: Vertical Wave Bending Moments**

Equation {3.4} specify: the wave bending moments at arbitrary positions along the length of the vessel for sagging and hogging should not be taken less than

$$M_W = k_{wm} \cdot M_{WO} \quad [\text{kNm}] \quad \text{Eq. \{3.4\}}$$

Wave bending moments may be reduced when hull girder stresses from loads are combined with local stresses /1/

$$M_{WR} = 0.59M_W \quad [\text{kNm}] \quad \text{Eq. \{3.7\}}$$

Read and interpolate Figure 3-3 in Section 3.2.2 and obtain values for  $k_{wm}$ .

$k_{wm} :=$

	0
0	0.25
1	0.5
2	0.75
3	1
4	0.714
5	0.429
6	0.143

**A.6.3.1: In sheltered areas or harbour**

$$M_{WO\_shelt\_S} := -0.11 \alpha_{shelt} \cdot C_W \cdot L_p^2 \cdot B \cdot (C_B + 0.7) (\text{kN}\cdot\text{m}) = -4.138 \times 10^5 \cdot \text{kN}\cdot\text{m}$$

$$M_{WO\_shelt\_H} := 0.19 \cdot \alpha_{shelt} \cdot C_W \cdot L_p^2 \cdot B \cdot C_B (\text{kN}\cdot\text{m}) = 3.805 \times 10^5 \cdot \text{kN}\cdot\text{m}$$

Sagging condition:

$$M_{W\_shelt\_S} := k_{wm} \cdot M_{WO\_shelt\_S} = \begin{pmatrix} -1.034 \times 10^5 \\ -2.069 \times 10^5 \\ -3.103 \times 10^5 \\ -4.138 \times 10^5 \\ -2.954 \times 10^5 \\ -1.775 \times 10^5 \\ -5.917 \times 10^4 \end{pmatrix} \cdot \text{kN}\cdot\text{m} \quad \text{Eq. \{3.4\}}$$

$$M_{WR\_shelt\_S} := 0.59 \cdot M_{W\_shelt\_S} = \begin{pmatrix} -6.103 \times 10^4 \\ -1.221 \times 10^5 \\ -1.831 \times 10^5 \\ -2.441 \times 10^5 \\ -1.743 \times 10^5 \\ -1.047 \times 10^5 \\ -3.491 \times 10^4 \end{pmatrix} \cdot kN \cdot m \quad \text{Eq. \{3.7\}}$$

Hogging condition:

$$M_{W\_shelt\_H} := k_{wm} \cdot M_{WO\_shelt\_H} = \begin{pmatrix} 9.512 \times 10^4 \\ 1.902 \times 10^5 \\ 2.854 \times 10^5 \\ 3.805 \times 10^5 \\ 2.717 \times 10^5 \\ 1.632 \times 10^5 \\ 5.441 \times 10^4 \end{pmatrix} \cdot kN \cdot m \quad \text{Eq. \{3.4\}}$$

$$M_{WR\_shelt\_H} := 0.59 \cdot M_{W\_shelt\_H} = \begin{pmatrix} 5.612 \times 10^4 \\ 1.122 \times 10^5 \\ 1.684 \times 10^5 \\ 2.245 \times 10^5 \\ 1.603 \times 10^5 \\ 9.631 \times 10^4 \\ 3.21 \times 10^4 \end{pmatrix} \cdot kN \cdot m \quad \text{Eq. \{3.7\}}$$



The design vertical wave bending moments in sheltered area or harbour condition are:

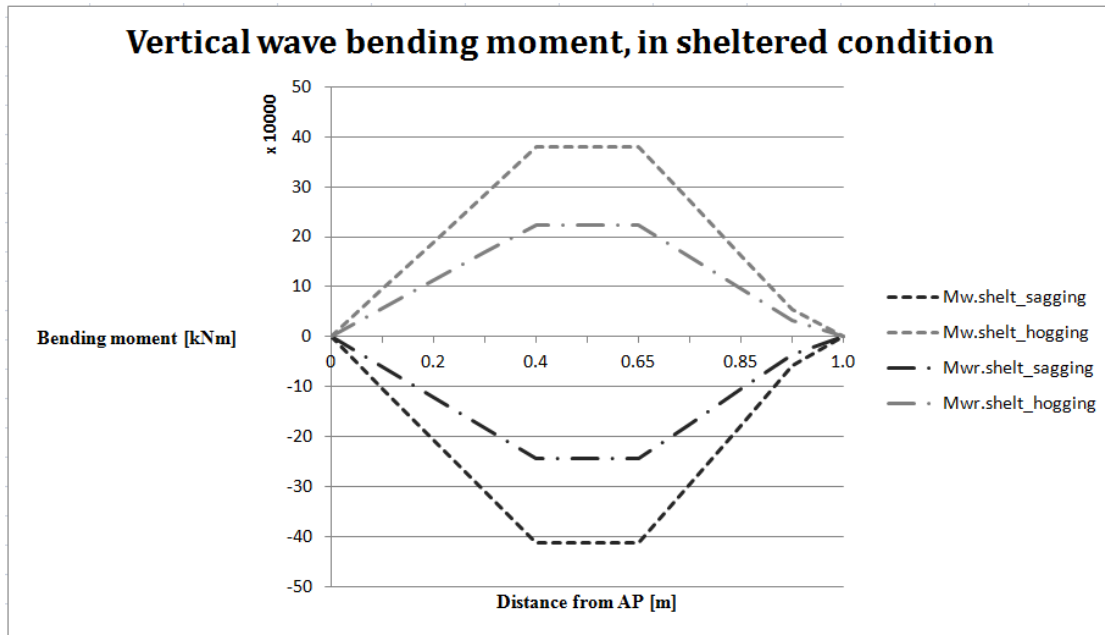

Distance from AP [m]	M <sub>w.shelt</sub>		M <sub>wr.shelt</sub>	
	Sagging [kNm]	Hogging [kNm]	Sagging [kNm]	Hogging [kNm]
0.0L	0	0	0	0
0.10L	-103400	95120	-61030	56120
0.20L	-206900	190200	-122100	112200
0.30L	-310300	285400	-183100	168400
0.40L	-413800	380500	-244100	224500
0.50L (= 72m)	-413800	380500	-244100	224500
0.65L	-413800	380500	-244100	224500
0.75L	-295400	271700	-174300	160300
0.85L	-177500	163200	-104700	96310
0.95L	-59130	54410	-34910	32100
1.0L	0	0	0	0

**A.6.3.2: At seagoing conditions**

$$\text{Sagging: } M_{WO\_seag\_S} := -0.11\alpha_{seag} \cdot C_W \cdot L_p^2 \cdot B \cdot (C_B + 0.7) (kN \cdot m) = -8.275 \times 10^5 \cdot kN \cdot m$$

$$\text{Hogging: } M_{WO\_seag\_H} := 0.19\alpha_{seag} \cdot C_W \cdot L_p^2 \cdot B \cdot C_B (kN \cdot m) = 7.61 \times 10^5 \cdot kN \cdot m$$

Sagging condition:

$$M_{W\_seag\_S} := k_{wm} \cdot M_{WO\_seag\_S} = \begin{pmatrix} -2.069 \times 10^5 \\ -4.138 \times 10^5 \\ -6.206 \times 10^5 \\ -8.275 \times 10^5 \\ -5.908 \times 10^5 \\ -3.55 \times 10^5 \\ -1.183 \times 10^5 \end{pmatrix} \cdot kN \cdot m \quad \text{Eq. \{3.4\}}$$

$$M_{WR\_seag\_S} := 0.59 \cdot M_{W\_seag\_S} = \begin{pmatrix} -1.221 \times 10^5 \\ -2.441 \times 10^5 \\ -3.662 \times 10^5 \\ -4.882 \times 10^5 \\ -3.486 \times 10^5 \\ -2.095 \times 10^5 \\ -6.982 \times 10^4 \end{pmatrix} \cdot kN \cdot m \quad \text{Eq. \{3.7\}}$$

Hogging condition:

$$M_{W\_seag\_H} := k_{wm} \cdot M_{WO\_seag\_H} = \begin{pmatrix} 1.902 \times 10^5 \\ 3.805 \times 10^5 \\ 5.707 \times 10^5 \\ 7.61 \times 10^5 \\ 5.433 \times 10^5 \\ 3.265 \times 10^5 \\ 1.088 \times 10^5 \end{pmatrix} \cdot kN \cdot m \quad \text{Eq. \{3.4\}}$$

$$M_{WR\_seag\_H} := 0.59 \cdot M_{W\_seag\_H} = \begin{pmatrix} 1.122 \times 10^5 \\ 2.245 \times 10^5 \\ 3.367 \times 10^5 \\ 4.49 \times 10^5 \\ 3.206 \times 10^5 \\ 1.926 \times 10^5 \\ 6.42 \times 10^4 \end{pmatrix} \cdot kN \cdot m \quad \text{Eq. \{3.7\}}$$

The design vertical wave bending moments under seagoing condition are:

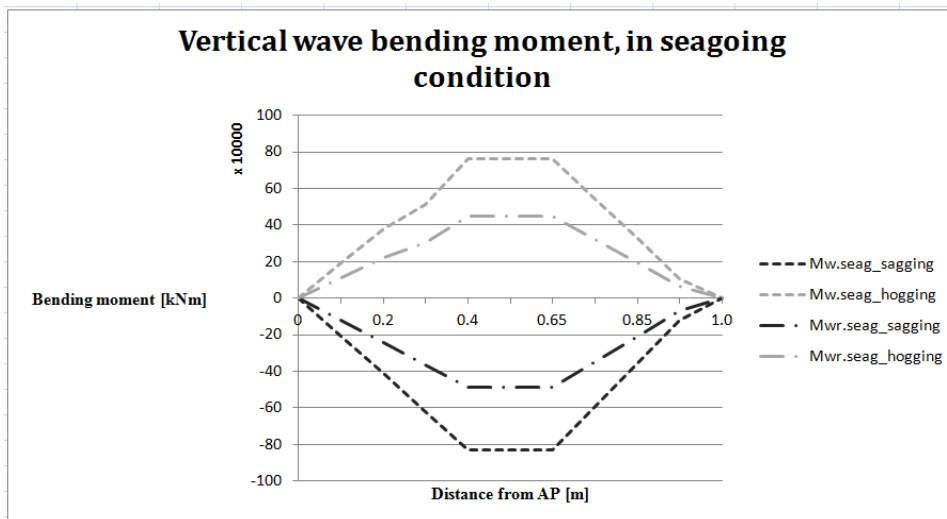

Distance from AP [m]	M <sub>w.seag</sub>		M <sub>wr.seag</sub>	
	Sagging [kNm]	Hogging [kNm]	Sagging [kNm]	Hogging [kNm]
0.0L	0	0	0	0
0.10L	-206900	190200	-122100	112200
0.20L	-413800	380500	-244100	224500
0.30L	-620600	570700	-366200	336700
0.40L	-827500	761000	-488200	449000
0.50L (= 72m)	-827500	761000	-488200	449000
0.65L	-827500	761000	-488200	449000
0.75L	-590800	543300	-348600	320600
0.85L	-355000	326500	-209500	192600
0.95L	-118300	108800	-69800	64200
1.0L	0	0	0	0

#### A.6.4: Vertical Wave Shear Forces

Equation {3.5} and {3.6} specify: the recommended design vertical wave shear forces along the ships length are not to be taken less than

$$Q_{WP} = 0.3\beta \cdot k_{wqp} \cdot C_w \cdot L_p \cdot B \cdot (C_B + 0.7) \quad [\text{kN}] \quad \text{Eq. \{4.5\}}$$

$$Q_{WN} = -0.3 \cdot \beta \cdot k_{wqn} \cdot C_w \cdot L_p \cdot B \cdot (C_B + 0.7) \quad [\text{kN}] \quad \text{Eq. \{4.6\}}$$

Wave shear forces may be reduced when hull girder stresses from loads are combined with local stresses /1/

$$Q_{WR} = 0.59Q_W \quad [\text{kNm}] \quad \text{Eq. \{4.8\}}$$

$$k_{wqp} :=$$

	0
0	0.423
1	0.847
2	0.7
3	1
4	0.333

$$k_{wqn} :=$$

	0
0	0.46
1	0.92
2	0.7
3	0.921
4	0.307

**A.6.4.1: In sheltered areas or harbour**

$$Q_{WP\_shelt} := 0.3\beta_{shelt} \cdot k_{wqp} \cdot C_W \cdot L_p \cdot B \cdot (C_B + 0.7) (kN \cdot m) = \begin{pmatrix} 3.36 \times 10^3 \\ 6.727 \times 10^3 \\ 5.56 \times 10^3 \\ 7.942 \times 10^3 \\ 2.645 \times 10^3 \end{pmatrix} \cdot kN \cdot m \quad \text{Eq. \{3.5\}}$$

$$Q_{WR.P.shelt} := 0.59 \cdot Q_{WP\_shelt} = \begin{pmatrix} 1.982 \times 10^3 \\ 3.969 \times 10^3 \\ 3.28 \times 10^3 \\ 4.686 \times 10^3 \\ 1.56 \times 10^3 \end{pmatrix} \cdot kN \cdot m \quad \text{Eq. \{3.8\}}$$

$$Q_{WN\_shelt} := -0.3\beta_{shelt} \cdot k_{wqn} \cdot C_W \cdot L_p \cdot B \cdot (C_B + 0.7) (kN \cdot m) = \begin{pmatrix} -3.653 \times 10^3 \\ -7.307 \times 10^3 \\ -5.56 \times 10^3 \\ -7.315 \times 10^3 \\ -2.438 \times 10^3 \end{pmatrix} \cdot kN \cdot m \quad \text{Eq. \{3.6\}}$$

$$Q_{WR.N.shelt} := 0.59 \cdot Q_{WN\_shelt} = \begin{pmatrix} -2.156 \times 10^3 \\ -4.311 \times 10^3 \\ -3.28 \times 10^3 \\ -4.316 \times 10^3 \\ -1.439 \times 10^3 \end{pmatrix} \cdot kN \cdot m \quad \text{Eq. \{3.8\}}$$

The design vertical wave shear forces under sheltered condition are:

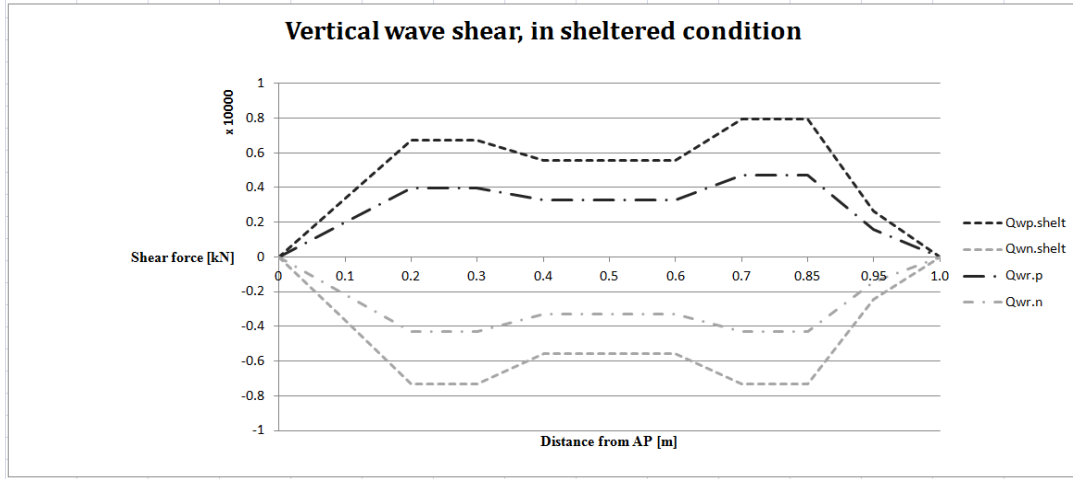

Distance from AP [m]	QW.shelt		QWR.shelt	
	$Q_{wp}$ [kN]	$Q_{wn}$ [kN]	$Q_{WR,P}$ [kN]	$Q_{WR,N}$ [kN]
0.0L	0	0	0	0
0.10L	3400	-3600	1900	-2200
0.20L	6700	-7300	4000	-4300
0.30L	6700	-7300	4000	-4300
0.40L	5600	-5600	3300	-3300
0.50L (= 72m)	5600	-5600	3300	-3300
0.60L	5600	-5600	3300	-3300
0.70L	7900	-7300	4700	-4300
0.85L	7900	-7300	4700	-4300
0.95L	2600	-2400	1600	-1400
1.0L	0	0	0	0

**A.6.4.2: Seagoing conditions**

$$Q_{WP\_seag} := 0.3\beta_{seag} \cdot k_{wqp} \cdot C_W \cdot L_p \cdot B \cdot (C_B + 0.7) (kN \cdot m) = \begin{pmatrix} 6.719 \times 10^3 \\ 1.345 \times 10^4 \\ 1.112 \times 10^4 \\ 1.588 \times 10^4 \\ 5.289 \times 10^3 \end{pmatrix} \cdot kN \cdot m \quad \text{Eq. \{3.5\}}$$

$$Q_{WR.P.seag} := 0.59 \cdot Q_{WP\_seag} = \begin{pmatrix} 3.964 \times 10^3 \\ 7.938 \times 10^3 \\ 6.56 \times 10^3 \\ 9.372 \times 10^3 \\ 3.121 \times 10^3 \end{pmatrix} \cdot kN \cdot m \quad \text{Eq. \{3.8\}}$$

$$Q_{WN\_seag} := -0.3\beta_{seag} \cdot k_{wqn} \cdot C_W \cdot L_p \cdot B \cdot (C_B + 0.7) (kN \cdot m) = \begin{pmatrix} -7.307 \times 10^3 \\ -1.461 \times 10^4 \\ -1.112 \times 10^4 \\ -1.463 \times 10^4 \\ -4.877 \times 10^3 \end{pmatrix} \cdot kN \cdot m \quad \text{Eq. \{3.6\}}$$

$$Q_{WR.N.seag} := 0.59 \cdot Q_{WN\_seag} = \begin{pmatrix} -4.311 \times 10^3 \\ -8.622 \times 10^3 \\ -6.56 \times 10^3 \\ -8.631 \times 10^3 \\ -2.877 \times 10^3 \end{pmatrix} \cdot kN \cdot m \quad \text{Eq. \{3.8\}}$$

The design vertical wave shear forces in seagoing condition are:

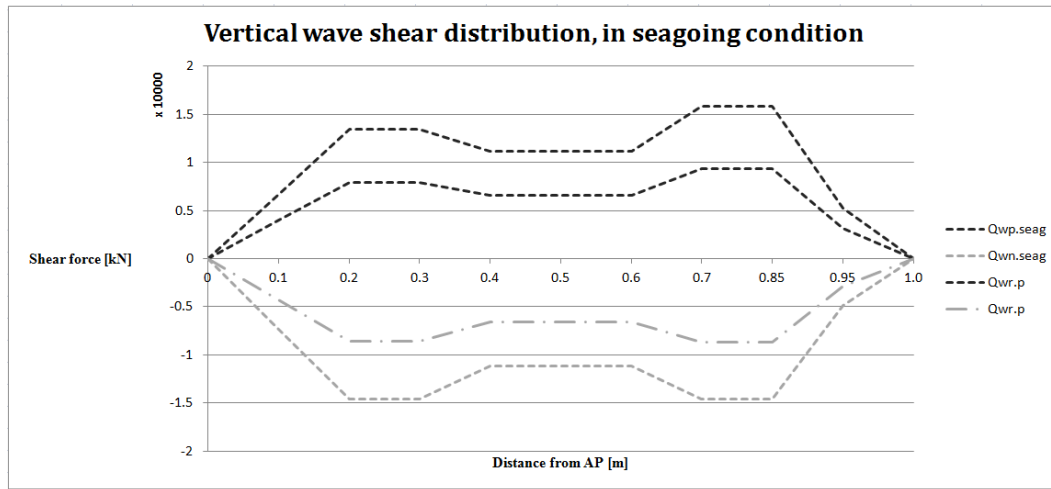

Distance from from AP [m]	$Q_{W.seag}$		$Q_{WR.seag}$	
	$Q_{WP} [kN]$	$Q_{WN} [kN]$	$Q_{WR.P} [kN]$	$Q_{WR.N} [kN]$
0.0L	0	0	0	0
0.10L	6700	-7300	4000	-4300
0.20L	13500	-14600	7900	-8600
0.30L	13500	-14600	7900	-8600
0.40L	11100	-11100	6600	-6600
0.50L (= 72m)	11100	-11100	6600	-6600
0.60L	11100	-11100	6600	-6600
0.70L	15900	-14600	9400	-8600
0.85L	15900	-14600	9400	-8600
0.95L	5300	-4900	3100	-2900
1.0L	0	0	0	0



**A.7: Combined Still-water and Vertical Wave loads**

This section combines the still-water and vertical wave bending moments and shear forces with accordance to DNV /3/. Considering the still-water and vertical wave at 0.5L (= 72m) from AP. The combination of still-water combined with vertical wave in seagoing condition are evaluated.

**A.7.1: Load and Resistance Factor Design (LRFD)****Load combination 1**

$$M_D = 1.2M_S + 0.7M_W$$

$$Q_D = 1.2Q_S + 0.7Q_W$$

*Sagging*

$$M_{D.1_S} := \left[ 1.2 \cdot (-4.89 \cdot 10^5) + 0.7 \cdot (-4.882 \cdot 10^5) \right] (kN \cdot m) = -9.285 \times 10^5 \cdot kN \cdot m$$

$$Q_{D.1_S} := \left[ 1.2 \cdot (-1.377 \cdot 10^4) + 0.7 \cdot (-6.56 \cdot 10^3) \right] (kN \cdot m) = -2.112 \times 10^4 \cdot kN \cdot m$$

*Hogging*

$$M_{D.1_H} := \left[ 1.2 \cdot (5.555 \cdot 10^5) + 0.7 \cdot (4.49 \cdot 10^5) \right] (kN \cdot m) = 9.809 \times 10^5 \cdot kN \cdot m$$

$$Q_{D.1_H} := \left[ 1.2 \cdot (1.564 \cdot 10^4) + 0.7 \cdot (6.56 \cdot 10^3) \right] (kN \cdot m) = 2.336 \times 10^4 \cdot kN \cdot m$$

**Load combination 2**

$$M_D = 1.0M_S + 1.15M_W$$

$$Q_D = 1.0Q_S + 1.15Q_W$$

*Sagging*

$$M_{D.2_S} := \left[ 1.0 \cdot (-4.89 \cdot 10^5) + 1.15 \cdot (-4.882 \cdot 10^5) \right] (kN \cdot m) = -1.05 \times 10^6 \cdot kN \cdot m$$

$$Q_{D.2_S} := \left[ 1.0 \cdot (-1.377 \cdot 10^4) + 1.15 \cdot (-6.56 \cdot 10^3) \right] (kN \cdot m) = -2.131 \times 10^4 \cdot kN \cdot m$$

*Hogging*

$$M_{D,2_H} := \left[ 1.0 \cdot (5.555 \cdot 10^5) + 1.15 \cdot (4.49 \cdot 10^5) \right] (kN \cdot m) = 1.072 \times 10^6 \cdot kN \cdot m$$

$$Q_{D,2_H} := \left[ 1.0 \cdot (1.564 \cdot 10^4) + 1.15 \cdot (6.56 \cdot 10^3) \right] (kN \cdot m) = 2.318 \times 10^4 \cdot kN \cdot m$$

## **APPENDIX B - STRENGTH DIAGRAMS, *SEVEN SEAS* STABILITY BOOKLET**

*Following loading conditions are taken from the booklet:*

(Loading Conditions 1, 2, 4, 5, 6, 7)



## B4. Loading Conditions

### Condition 1: Lightship (For information only)

#### Condition Summary

Deadweight	1919.50 t	GMt fluid	4.544 m	Perm. BM/SF Set	BM+SF 08-05-2006
Displ.	12829 t	Perm. GM	m	GM/KG LimCurve Set	710 GM Limiting curve Intact+Damage 18-03-2008
Draft Mean (Moulded)	4.390 m	KGt fluid	13.771 m	Area WP	3230 m <sup>2</sup>
Draft FP (Moulded)	5.33 m	LCG (Fwd of Fro)	72.69 m	Immersion (TPC/TPI)	33.11 t/cm
Draft AP (Moulded)	3.45 m	TCG (SB:+)	-0.21 m	Moment Change Trim	285.95 t-m/cm
Trim (ByBow:+)	1.88 m	LCF (Fwd of Fro)	67.88 m	Rolling Period	12.33 s
Heel	-2.67 deg	KMt	18.32 m	Sea Dens.	1.025 t/m <sup>3</sup>
GMt solid	4.544 m	Max %SF	-56.58 %		
FSM Corr	0.00 m	Max %BM	48.95 %		

#### Deadweight Summary

Group Name	Density	Weight	Filling	Long.Pos	TCG	VCG	F.S. Mom.
				Fwd of Fro	SB:+	Above BL	t-m
	t/m <sup>3</sup>	t		m	m	m	
Sea		0.0	0.00				0
Void		0.0	0.00				0
Water Ballast		0.0	0.00				0
Heel-Stab Water		0.0	0.00				0
Marine Gas Oil		0.0	0.00				0
Int Fuel Oil		0.0	0.00				0
Fresh Water		0.0	0.00				0
Technical Freshwater		0.0	0.00				0
Lub Oil		0.0	0.00				0
ER Tanks		0.0	0.00				0
Hydraulic Oil		0.0	0.00				0
Compartments		0.0	0.00				0
Ships crew		0.0	0.00				0
Provisions		0.0	0.00				0
HI equipment		0.0	0.00				0
Pipe		0.0	0.00				0
ROV equipment	1.00	185.5	1.00	87.000	0.000	17.700	0
Pipelay Equipment movable	1.00	1734.0	0.18	65.923	-0.942	28.997	0
Freely placed Unit Loads		0.0					0
Deadweight		1919.5		67.960	-0.851	27.905	0
Lightship		10909.6		73.523	-0.098	11.285	
Displacement		12829.1		72.691	-0.211	13.771	
Buoyancy		12829.1		72.846	-0.743	2.349	



STABILITY BOOKLET Flex-lay construction vessel  
YARD NUMBER 710  
APPENDIX B4

Strength Diagram

Permissible SF & BM: "BM+SF 08-05-2006"  
Permissible TM: not set

Max SF: -905 t at X 62.8 m Fr 84dx0.0 m  
Max % perm. SF: -56.6 % at X 62.8 m Fr 84dx0.0 m  
Max BM: 15468 t-m at X 33.6 m Fr 46dx0.5 m  
Max % perm. BM: 48.9 % at X 33.6 m Fr 46dx0.5 m  
Max TM: 4263 t-m at X 43.3 m Fr 59dx0.0 m

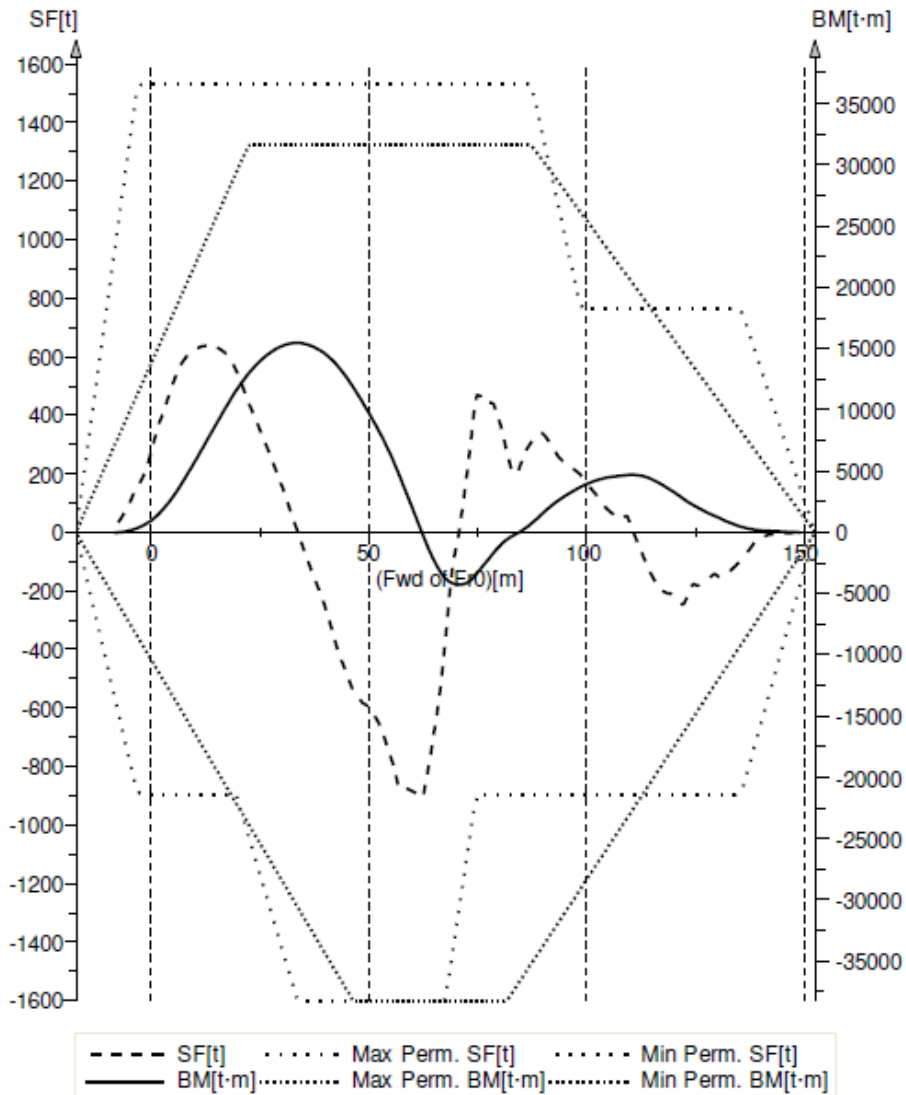



STABILITY BOOKLET Flex-lay construction vessel  
YARD NUMBER 710  
APPENDIX B4

## Condition 2: Docking Minimum Stores

### Condition Summary

Deadweight	5117.57 t	GMt fluid	4.170 m	Perm. BM/SF Set	BM+SF 08-05-2006
Displ.	16027 t	Perm. GM	2.07 m	GM/KG LimCurve Set	710 GM Limiting curve Intact+Damage 18-03-2008
Draft Mean (Moulded)	5.284 m	KGt fluid	12.369 m	Area WP	3451 m <sup>2</sup>
Draft FP (Moulded)	5.26 m	LCG (Fwd of Fro)	67.56 m	Immersion (TPC/TPI)	35.37 t/cm
Draft AP (Moulded)	5.31 m	TCG (SB:+)	-0.02 m	Moment Change Trim	344.63 t-m/cm
Trim (ByBow:+)	-0.05 m	LCF (Fwd of Fro)	63.95 m	Rolling Period	12.07 s
Heel	-0.19 deg	KMt	16.54 m	Sea Dens.	1.025 t/m <sup>3</sup>
GMt solid	4.440 m	Max %SF	-38.12 %		
FSM Corr	0.27 m	Max %BM	39.16 %		

The condition satisfies all the stability requirements imposed by the limiting curve "710 GM Limiting curve Intact+Damage 18-03-2008"!

The Stability Criteria Set "IMO A749 (Intact stab)" is satisfied for both heeling directions (PORT and STARBOARD)!

The Bending Moments are within the permissible values specified by "BM+SF 08-05-2006"!

The Shear Forces are within the permissible values specified by "BM+SF 08-05-2006"!

### Deadweight Summary

Group Name	Density	Weight	Filling	Long.Pos	TCG	VCG	F.S. Mom.
				Fwd of Fro	SB:+	Above BL	
	t/m <sup>3</sup>	t		m	m	m	t-m
Water Ballast	1.02	1285.3	0.28	39.601	1.995	5.274	376
Heel-Stab Water	1.02	995.4	0.43	17.657	-0.001	6.354	280
Marine Gas Oil	0.89	197.3	0.09	96.703	-0.321	5.512	1459
Int Fuel Oil	0.99	174.0	0.12	109.226	-0.005	7.793	231
Fresh Water	1.00	64.6	0.10	115.733	-0.002	2.549	159
Technical Freshwater	1.00	364.6	0.53	53.307	-0.152	0.712	1275
Lub Oil	0.90	3.9	0.10	71.904	3.423	7.073	8
ER Tanks	0.85	15.0	0.10	100.359	-0.568	0.064	548
Hydraulic Oil	0.90	1.2	0.10	75.608	9.932	8.747	1
Ships crew	1.00	25.0	1.00	106.500	0.000	22.000	0
Provisions	1.00	20.0	0.10	106.500	0.000	12.500	0
HI equipment		0.0	0.00				0
Pipe		0.0	0.00				0
ROV equipment	1.00	185.5	1.00	87.000	0.000	17.700	0
Pipelay Equipment movable	1.00	1785.8	0.18	69.668	-0.915	28.384	0
Freely placed Unit Loads		0.0					0
Deadweight		5117.6		54.847	0.162	13.831	4338
Lightship		10909.6		73.523	-0.098	11.285	
Displacement		16027.2		67.560	-0.015	12.098	
Buoyancy		16027.2		67.556	-0.047	2.806	



STABILITY BOOKLET Flex-lay construction vessel  
YARD NUMBER 710  
APPENDIX B4

Strength Diagram

Permissible SF & BM: "BM+SF 08-05-2006"  
Permissible TM: not set

Max SF:	-610 t at	X 65.9 m	Fr 85dx0.0 m
Max % perm. SF:	-38.1 % at	X 65.9 m	Fr 85dx0.0 m
Max BM:	12375 t·m at	X 35.9 m	Fr 49dx0.3 m
Max % perm. BM:	39.2 % at	X 35.9 m	Fr 49dx0.3 m
Max TM:	2716 t·m at	X 40.0 m	Fr 54dx0.6 m

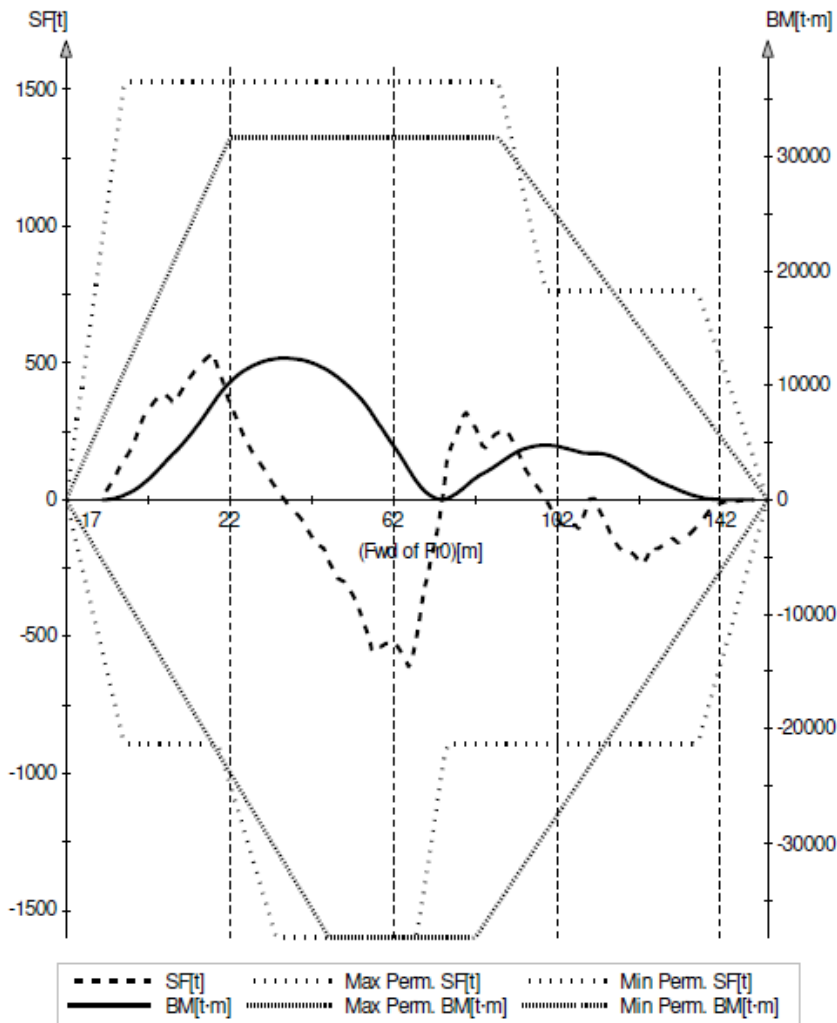

**Condition 4: Sailing condition - loaded for flex lay no deck carousel (all fuel 100%)****Condition Summary**

Deadweight	12674.53 t	GMt fluid	2.587 m	Perm. BM/SF Set	BM+SF 08-05-2006
Displ.	23584 t	Perm. GM	1.78 m	GM/KG LimCurve Set	710 GM Limiting curve Intact+Damage 18-03-2008
Draft Mean (Moulded)	7.341 m	KGt fluid	11.644 m	Area WP	3709 m <sup>2</sup>
Draft FP (Moulded)	7.35 m	LCG (Fwd of Fr0)	66.00 m	Immersion (TPC/TPI)	38.02 t/cm
Draft AP (Moulded)	7.33 m	TCG (SB:+)	0.00 m	Moment Change Trim	419.82 t-m/cm
Trim (ByBow:+)	0.02 m	LCF (Fwd of Fr0)	61.08 m	Rolling Period	14.26 s
Heel	0.00 deg	KMt	14.23 m	Sea Dens.	1.025 t/m <sup>3</sup>
GMt solid	3.919 m	Max %SF	81.74 %		
FSM Corr	1.33 m	Max %BM	42.54 %		

The condition satisfies all the stability requirements imposed by the limiting curve "710 GM Limiting curve Intact+Damage 18-03-2008"!

The Stability Criteria Set "IMO A749 (Intact stab)" is satisfied for both heeling directions (PORT and STARBOARD)!

The Bending Moments are within the permissible values specified by "BM+SF 08-05-2006"!

The Shear Forces are within the permissible values specified by "BM+SF 08-05-2006"!

**Deadweight Summary**

Group Name	Density	Weight	Filling	Long.Pos	TCG	VCG	F.S. Mom.
				Fwd of Fr0	SB:+	Above BL	
	t/m <sup>3</sup>	t		m	m	m	t-m
Water Ballast	1.02	1054.6	0.23	10.502	0.872	6.795	10522
Heel-Stab Water	1.02	1615.3	0.70	30.599	0.000	9.581	13537
Marine Gas Oil	0.89	2214.7	0.96	89.978	-0.026	3.774	3563
Int Fuel Oil	0.99	1304.2	0.93	72.404	1.298	3.910	752
Fresh Water	1.00	621.9	0.96	116.107	0.000	6.828	240
Technical Freshwater	1.00	656.7	0.96	60.658	-0.078	0.721	2230
Lub Oil	0.90	40.7	0.98	74.839	3.653	8.149	8
ER Tanks	0.85	112.2	0.75	100.372	-0.442	0.480	548
Hydraulic Oil	0.90	9.6	0.98	63.990	10.500	10.129	1
Ships crew	1.00	25.0	1.00	106.500	0.000	22.000	0
Provisions	1.00	200.0	1.00	106.500	0.000	12.500	0
HI equipment		0.0	0.00				0
Pipe	1.00	400.0	0.01	43.765	0.000	16.500	0
ROV equipment	1.00	185.5	1.00	87.000	0.000	17.700	0
Pipelay Equipment movable	1.00	1734.0	0.18	69.789	-0.942	28.874	0
Freely placed Unit Loads		0.0					0
Flexible Pipe 1T/M3		2500.0		37.860	0.000	6.316	0
Deadweight		12674.5		59.525	0.084	9.475	31400
Lightship		10909.6		73.523	-0.098	11.285	
Displacement		23584.1		66.000	0.000	10.312	
Buoyancy		23584.1		66.001	0.000	3.934	





STABILITY BOOKLET Flex-lay construction vessel  
YARD NUMBER 710  
APPENDIX B4

Strength Diagram

Permissible SF & BM: "BM+SF 08-05-2006"  
Permissible TM: not set

Max SF:	-815 t at	X 44.1 m	Fr 60dx-0.0 m
Max % perm. SF:	81.7 % at	X 102.6 m	Fr132dx-0.0 m
Max BM:	-13420 t-m at	X 75.2 m	Fr 96dx0.7 m
Max % perm. BM:	42.5 % at	X 8.4 m	Fr 13dx0.6 m
Max TM:	3611 t-m at	X 43.3 m	Fr 59dx0.0 m

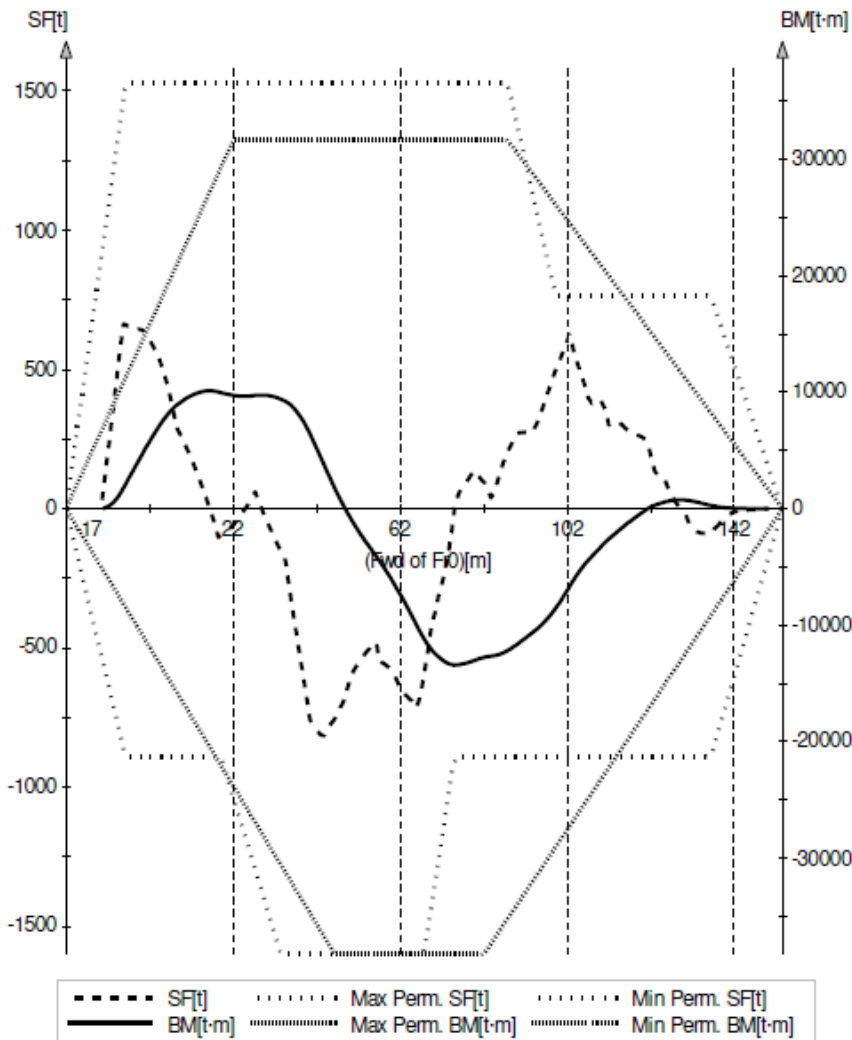



**Condition 5: Sailing condition - loaded for flex lay no deck carousel (IFO 100%, MGO 10%)**

**Condition Summary**

Deadweight	9932.48 t	GMt fluid	2.455 m	Perm. BM/SF Set	BM+SF 08-05-2006
Displ.	20842 t	Perm. GM	1.88 m	GM/KG LimCurve Set	710 GM Limiting curve Intact+Damage 18-03-2008
Draft Mean (Moulded)	6.570 m	KGt fluid	12.463 m	Area WP	3656 m <sup>2</sup>
Draft FP (Moulded)	6.21 m	LCG (Fwd of Fr0)	65.16 m	Immersion (TPC/TPI)	37.47 t/cm
Draft AP (Moulded)	6.93 m	TCG (SB:+)	0.00 m	Moment Change Trim	404.37 t-m/cm
Trim (ByBow:+)	-0.72 m	LCF (Fwd of Fr0)	61.17 m	Rolling Period	14.84 s
Heel	0.00 deg	KMt	14.92 m	Sea Dens.	1.025 t/m <sup>3</sup>
GMt solid	3.851 m	Max %SF	-50.20 %		
FSM Corr	1.40 m	Max %BM	50.07 %		

The condition satisfies all the stability requirements imposed by the limiting curve "710 GM Limiting curve Intact+Damage 18-03-2008"!

The Stability Criteria Set "IMO A749 (Intact stab)" is satisfied for both heeling directions (PORT and STARBOARD)!

The Bending Moments are within the permissible values specified by "BM+SF 08-05-2006"!

The Shear Forces are within the permissible values specified by "BM+SF 08-05-2006"!

**Deadweight Summary**

Group Name	Density	Weight	Filling	Long.Pos	TCG	VCG	F.S. Mom.
				Fwd of Fr0	SB:+	Above BL	
	t/m <sup>3</sup>	t		m	m	m	t-m
Water Ballast	1.02	1054.6	0.23	10.481	0.872	6.796	10522
Heel-Stab Water	1.02	890.7	0.38	35.142	0.000	11.447	13451
Marine Gas Oil	0.89	197.3	0.09	96.295	-0.295	5.513	1459
Int Fuel Oil	0.99	1304.2	0.93	72.384	1.298	3.910	752
Fresh Water	1.00	621.9	0.96	116.105	0.000	6.828	240
Technical Freshwater	1.00	656.7	0.96	60.571	-0.078	0.721	2116
Lub Oil	0.90	40.7	0.98	74.838	3.653	8.149	8
ER Tanks	0.85	112.2	0.75	100.366	-0.444	0.480	548
Hydraulic Oil	0.90	9.6	0.98	63.989	10.500	10.129	1
Ships crew	1.00	25.0	1.00	106.500	0.000	22.000	0
Provisions	1.00	200.0	1.00	106.500	0.000	12.500	0
HI equipment		0.0	0.00				0
Pipe	1.00	400.0	0.01	43.765	0.000	16.500	0
ROV equipment	1.00	185.5	1.00	87.000	0.000	17.700	0
Pipelay Equipment movable	1.00	1734.0	0.18	69.789	-0.942	28.874	0
Freely placed Unit Loads		0.0					0
Flexible Pipe 1T/M3		2500.0		37.860	0.000	6.316	0
Deadweight		9932.5		55.972	0.108	10.827	29097
Lightship		10909.6		73.523	-0.098	11.285	
Displacement		20842.1		65.159	0.000	11.067	
Buoyancy		20842.1		65.120	0.000	3.537	



STABILITY BOOKLET Flex-lay construction vessel  
YARD NUMBER 710  
APPENDIX B4

Strength Diagram

Permissible SF & BM: "BM+SF 08-05-2006"  
Permissible TM: not set

Max SF:	-803 t at	X 43.3 m	Fr 59dx0.0 m
Max % perm. SF:	-50.2 % at	X 43.3 m	Fr 59dx0.0 m
Max BM:	14208 t-m at	X 22.6 m	Fr 32dx0.4 m
Max % perm. BM:	50.1 % at	X 12.9 m	Fr 19dx0.8 m
Max TM:	3608 t-m at	X 43.3 m	Fr 59dx0.0 m

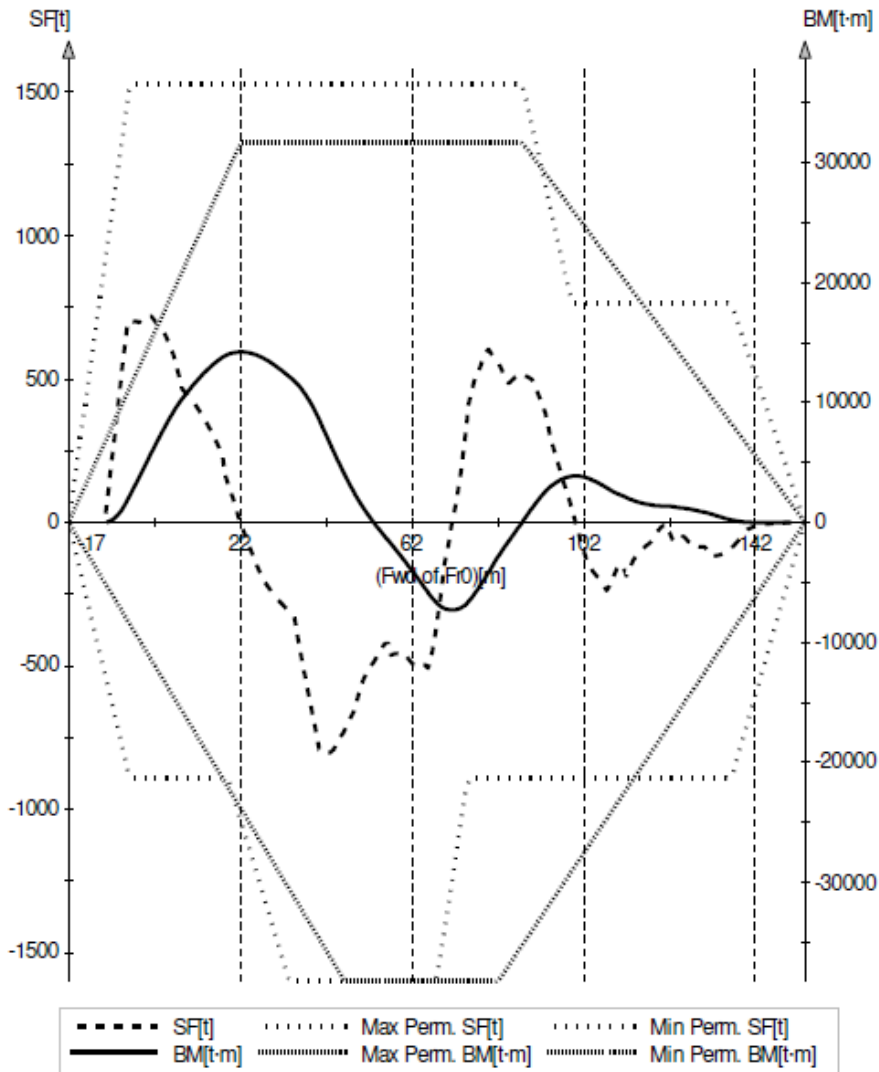



STABILITY BOOKLET Flex-lay construction vessel  
YARD NUMBER 710  
APPENDIX B4

**Condition 6: Sailing condition - loaded for flex lay no deck carousel (IFO 10%,  
MGO 100%)**

**Condition Summary**

Deadweight	11672.04 t	GMt fluid	2.460 m	Perm. BM/SF Set	BM+SF 08-05-2006
Displ.	22582 t	Perm. GM	1.82 m	GM/KG LimCurve Set	710 GM Limiting curve Intact+Damage 18-03-2008
Draft Mean (Moulded)	7.062 m	KGt fluid	11.991 m	Area WP	3690 m <sup>2</sup>
Draft FP (Moulded)	6.95 m	LCG (Fwd of Fr0)	65.76 m	Immersion (TPC/TPI)	37.82 t/cm
Draft AP (Moulded)	7.17 m	TCG (SB:+)	0.00 m	Moment Change Trim	414.10 t-m/cm
Trim (ByBow:+)	-0.23 m	LCF (Fwd of Fr0)	61.13 m	Rolling Period	14.57 s
Heel	0.00 deg	KMt	14.45 m	Sea Dens.	1.025 t/m <sup>3</sup>
GMt solid	3.824 m	Max %SF	46.54 %		
FSM Corr	1.36 m	Max %BM	45.21 %		

The condition satisfies all the stability requirements imposed by the limiting curve "710 GM Limiting curve Intact+Damage 18-03-2008"

The Stability Criteria Set "IMO A749 (Intact stab)" is satisfied for both heeling directions (PORT and STARBOARD)!

The Bending Moments are within the permissible values specified by "BM+SF 08-05-2006"

The Shear Forces are within the permissible values specified by "BM+SF 08-05-2006"

**Deadweight Summary**

Group Name	Density	Weight	Filling	Long.Pos	TCG	VCG	F.S. Mom.
				Fwd of Fr0	SB:+	Above BL	t-m
	t/m <sup>3</sup>	t		m	m	m	t-m
Water Ballast	1.02	1196.1	0.26	13.501	2.186	6.678	10522
Heel-Stab Water	1.02	1601.6	0.69	30.102	0.000	9.466	13537
Marine Gas Oil	0.89	2214.7	0.96	89.953	-0.026	3.775	3491
Int Fuel Oil	0.99	174.0	0.12	109.225	0.000	7.793	231
Fresh Water	1.00	621.9	0.96	116.106	0.000	6.828	240
Technical Freshwater	1.00	656.7	0.96	60.629	-0.077	0.721	2230
Lub Oil	0.90	40.7	0.98	74.838	3.653	8.149	8
ER Tanks	0.85	112.2	0.75	100.370	-0.443	0.480	548
Hydraulic Oil	0.90	9.6	0.98	63.990	10.500	10.129	1
Ships crew	1.00	25.0	1.00	106.500	0.000	22.000	0
Provisions	1.00	200.0	1.00	106.500	0.000	12.500	0
HI equipment		0.0	0.00				0
Pipe	1.00	400.0	0.01	43.765	0.000	16.500	0
ROV equipment	1.00	185.5	1.00	87.000	0.000	17.700	0
Pipelay Equipment movable	1.00	1734.0	0.18	69.789	-0.942	28.874	0
Freely placed Unit Loads		0.0					0
Flexible Pipe 1T/M3		2500.0		37.860	0.000	6.316	0
Deadweight		11672.0		58.499	0.092	10.012	30808
Lightship		10909.6		73.523	-0.098	11.285	
Displacement		22581.6		65.757	0.000	10.627	
Buoyancy		22581.6		65.746	0.000	3.789	



STABILITY BOOKLET Flex-lay construction vessel  
YARD NUMBER 710  
APPENDIX B4

Strength Diagram

Permissible SF & BM: "BM+SF 08-05-2006"  
Permissible TM: not set

Max SF:	-678 t at	X 65.9 m	Fr 85dx0.0 m
Max % perm. SF:	46.5 % at	X 102.6 m	Fr132dx-0.0 m
Max BM:	13729 t-m at	X 36.0 m	Fr 49dx0.5 m
Max % perm. BM:	45.2 % at	X 9.2 m	Fr 15dx0.2 m
Max TM:	5223 t-m at	X 43.3 m	Fr 59dx0.0 m

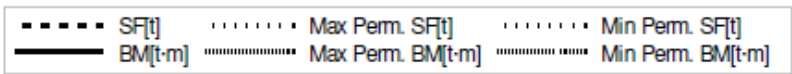
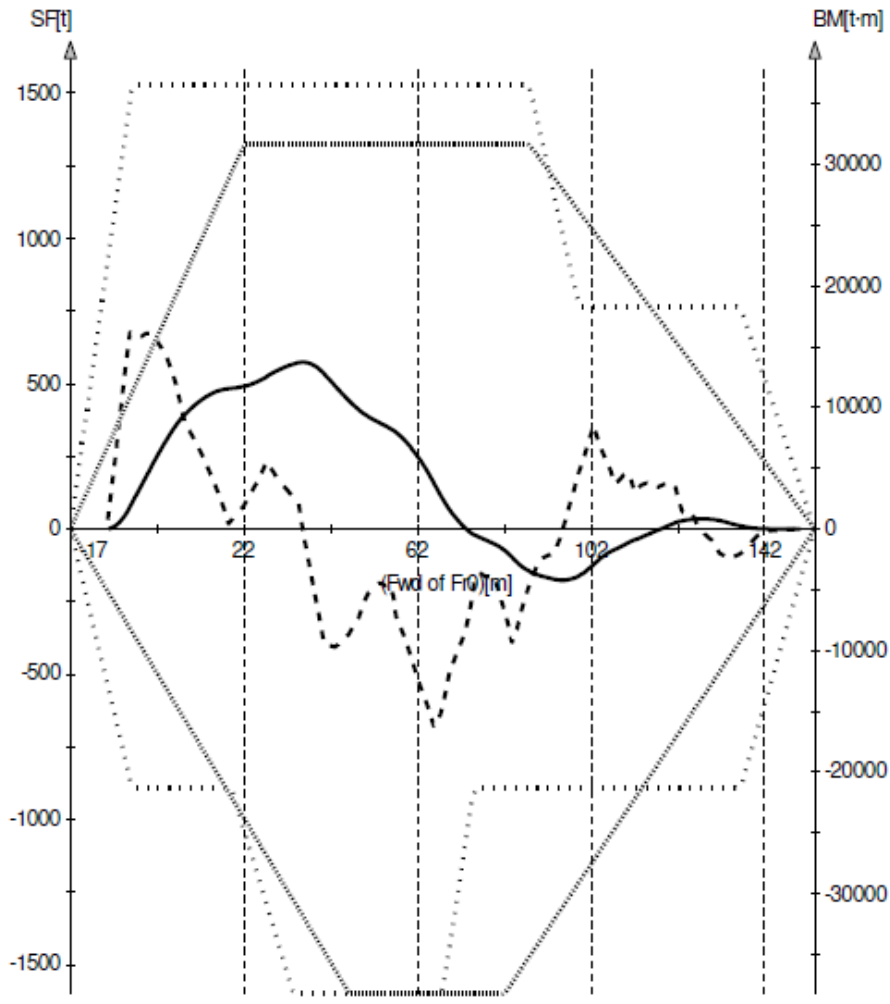

**Condition 7: Sailing condition - loaded for flex lay no deck carousel (IFO 50%, MGO 50%)****Condition Summary**

<b>Deadweight</b>	9034.62 t	<b>GMt fluid</b>	2.524 m	<b>Perm. BM/SF Set</b>	BM+SF 08-05-2006
<b>Displ.</b>	19944 t	<b>Perm. GM</b>	1.91 m	<b>GM/KG LimCurve Set</b>	710 GM Limiting curve Intact+Damage 18-03-2008
<b>Draft Mean (Moulded)</b>	6.349 m	<b>KGt fluid</b>	12.585 m	<b>Area WP</b>	3618 m <sup>2</sup>
<b>Draft FP (Moulded)</b>	6.16 m	<b>LCG (Fwd of Fr0)</b>	66.02 m	<b>Immersion (TPC/TPI)</b>	37.08 t/cm
<b>Draft AP (Moulded)</b>	6.54 m	<b>TCG (SB:+)</b>	0.00 m	<b>Moment Change Trim</b>	392.89 t-m/cm
<b>Trim (ByBow:+)</b>	-0.38 m	<b>LCF (Fwd of Fr0)</b>	61.77 m	<b>Rolling Period</b>	14.75 s
<b>Heel</b>	0.03 deg	<b>KMt</b>	15.11 m	<b>Sea Dens.</b>	1.025 t/m <sup>3</sup>
<b>GMt solid</b>	4.000 m	<b>Max %SF</b>	51.86 %		
<b>FSM Corr</b>	1.48 m	<b>Max %BM</b>	55.74 %		

The condition satisfies all the stability requirements imposed by the limiting curve "710 GM Limiting curve Intact+Damage 18-03-2008"

The Stability Criteria Set "IMO A749 (Intact stab)" is satisfied for both heeling directions (PORT and STARBOARD)!

The Bending Moments are within the permissible values specified by "BM+SF 08-05-2006"!

The Shear Forces are within the permissible values specified by "BM+SF 08-05-2006"!

**Deadweight Summary**

Group Name	Density	Weight	Filling	Long.Pos	TCG	VCG	F.S.
							Mom.
	t/m <sup>3</sup>	t		Fwd of Fr0	SB:+	Above BL	t-m
				m	m	m	
Water Ballast	1.02	1206.6	0.26	13.692	2.274	6.679	10522
Heel-Stab Water	1.02	336.1	0.14	72.581	0.018	17.773	13356
Marine Gas Oil	0.89	1005.4	0.44	83.384	-0.057	1.646	2966
Int Fuel Oil	0.99	753.8	0.54	80.832	0.000	4.161	575
Fresh Water	1.00	323.2	0.50	116.007	0.000	4.882	200
Technical Freshwater	1.00	364.6	0.53	53.259	-0.138	0.712	1275
Lub Oil	0.90	20.8	0.50	74.838	3.653	7.611	8
ER Tanks	0.85	74.8	0.50	100.367	-0.441	0.320	548
Hydraulic Oil	0.90	4.9	0.50	63.989	10.500	9.380	1
Ships crew	1.00	25.0	1.00	106.500	0.000	22.000	0
Provisions	1.00	100.0	0.50	106.500	0.000	12.500	0
HI equipment		0.0	0.00				0
Pipe	1.00	400.0	0.01	43.765	0.000	16.500	0
ROV equipment	1.00	185.5	1.00	87.000	0.000	17.700	0
Pipelay Equipment movable	1.00	1734.0	0.18	69.789	-0.942	28.874	0
Freely placed Unit Loads		0.0					0
Flexible Pipe 1T/M3		2500.0		37.860	0.000	6.316	0
Deadweight		9034.6		56.957	0.122	10.895	29450
Lightship		10909.6		73.523	-0.098	11.285	
Displacement		19944.2		66.019	0.002	11.108	
Buoyancy		19944.7		65.997	0.005	3.401	



STABILITY BOOKLET Flex-lay construction vessel  
YARD NUMBER 710  
APPENDIX B4

Strength Diagram

Permissible SF & BM: "BM+SF 08-05-2006"  
Permissible TM: not set

Max SF:	793 t at	X 1.8 m	Fr 3dx0.0 m
Max % perm. SF:	51.9 % at	X 1.8 m	Fr 3dx0.0 m
Max BM:	14138 t-m at	X 17.4 m	Fr 25dx0.6 m
Max % perm. BM:	55.7 % at	X 11.7 m	Fr 18dx0.4 m
Max TM:	5279 t-m at	X 43.3 m	Fr 59dx0.0 m

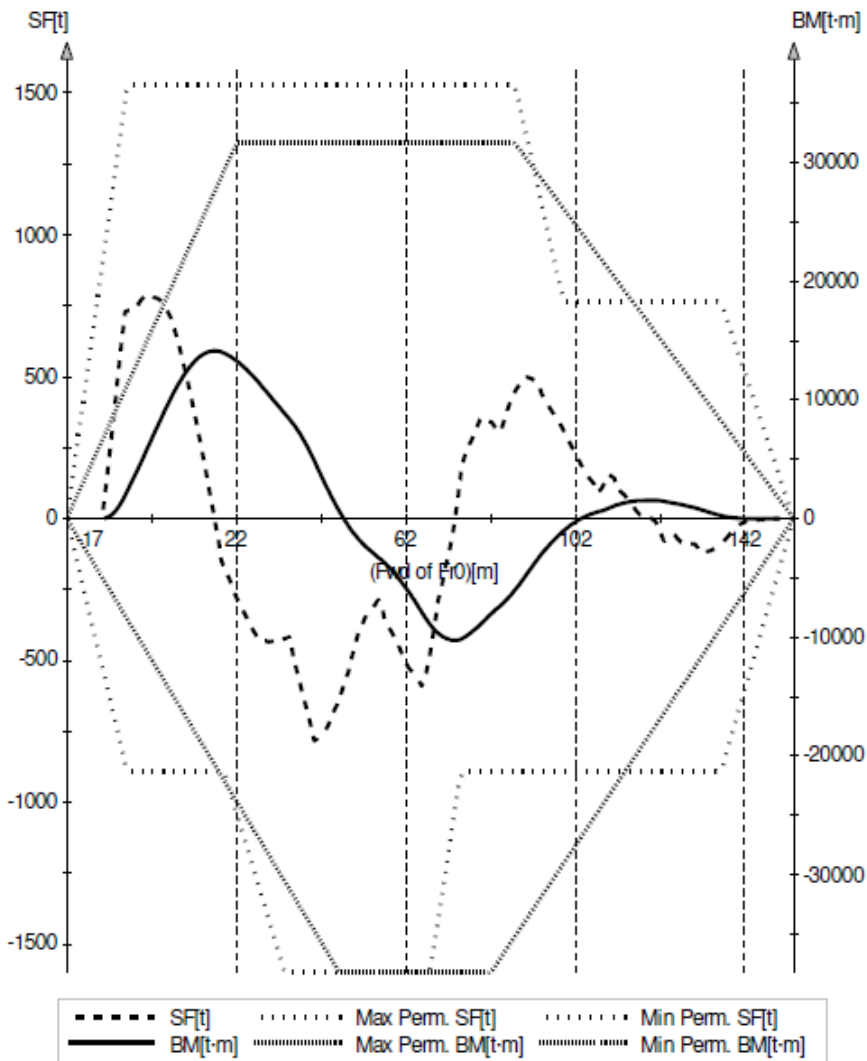

**APPENDIX C - LONGITUDINAL STRENGTH DIAGRAM  
RETRIEVED FROM THE *SEVEN SEAS*.**



LOADING CONDITION: LIGHSHIPLONGSTRENGTH

FLOATING POSITION

Drafts at marks, measured below the keel.  
 Trim is the difference of drafts at perpendiculars.  
 Sea water density 1.025

Mid draft	4.58	m	KM	17.96	m
Aft draft	4.26	m	KG	13.80	m
Fwd draft	4.97	m	GMO	4.16	m
Trim	F 0.89	m	GMcorr	0.00	m
Heel	S 0.14	deg	GMf	4.16	m

Eq. Draft	4.57	m	--> GMreq	4.78	m
Deflection	0.00	m	GMres	-0.61	m

WARNING: THE STABILITY CRITERIA ARE NOT MET !

HYDROSTATICS

LCF 66.46 m    LCB 70.35 m    LCG 70.27m    MCT 307.47 tm/cm    TPC 33.77 t/cm

SUMMARY OF LOADS

MASS LOADS					#Aft	#Fwd	Length
-----							
400TAFT	400.0	1.00	0.00	14.75	-15.0	17.6	20.00
910-ROV_HANDLING	165.0	87.00	0.00	17.70	108.0	120.0	9.36
920-ROV_EQUIPMENT	20.5	87.00	0.00	17.70	108.0	120.0	9.36
930-RAMP90	438.0	70.53	-0.30	35.30	84.0	96.0	11.70
931-LOWER_TENSIONER90	347.0	66.03	0.00	24.40	84.0	89.0	6.24
933-UPPER_TENSIONER90	270.0	66.23	0.00	39.70	84.0	89.0	6.24
935-ADJUSTERS90	56.0	77.83	0.00	30.20	93.0	104.0	8.58
936-J-LAY_MODULE90	159.0	70.33	-9.50	42.50	89.0	98.0	7.02
939-J-LAY_LOADER	85.0	46.75	4.15	15.04	36.0	84.8	39.78
941-J-LAY_LOADER_FIX	39.0	63.22	10.03	14.91	81.0	84.8	4.68
942-DECK_CHUTE	10.1	41.37	-6.90	19.60	54.0	61.0	5.46
943-MUSHROOM	47.3	31.72	-6.90	19.43	36.7	51.5	11.58
944-PLET_SYSTEM	80.2	46.55	0.00	13.00	51.0	81.0	23.40
BOOM	85.1	74.32	-11.90	31.82	84.5	108.6	20.00
STRUCTURE200T	200.0	53.76	14.20	13.50	72.0	72.8	0.60
WIRE_IN_SPOOL	117.3	73.89	5.74	3.90	88.8	101.6	10.00
-----							
TOTAL	2519.5	56.20	0.48	24.67			
-----							
Lightweight	10909.6	73.52	-0.10	11.28			
Deadweight	2519.5	56.20	0.48	24.67			
Total weight	13429.1	70.27	0.01	13.80			

LOADING CONDITION: LIGHSHIPLONGSTRENGTH,

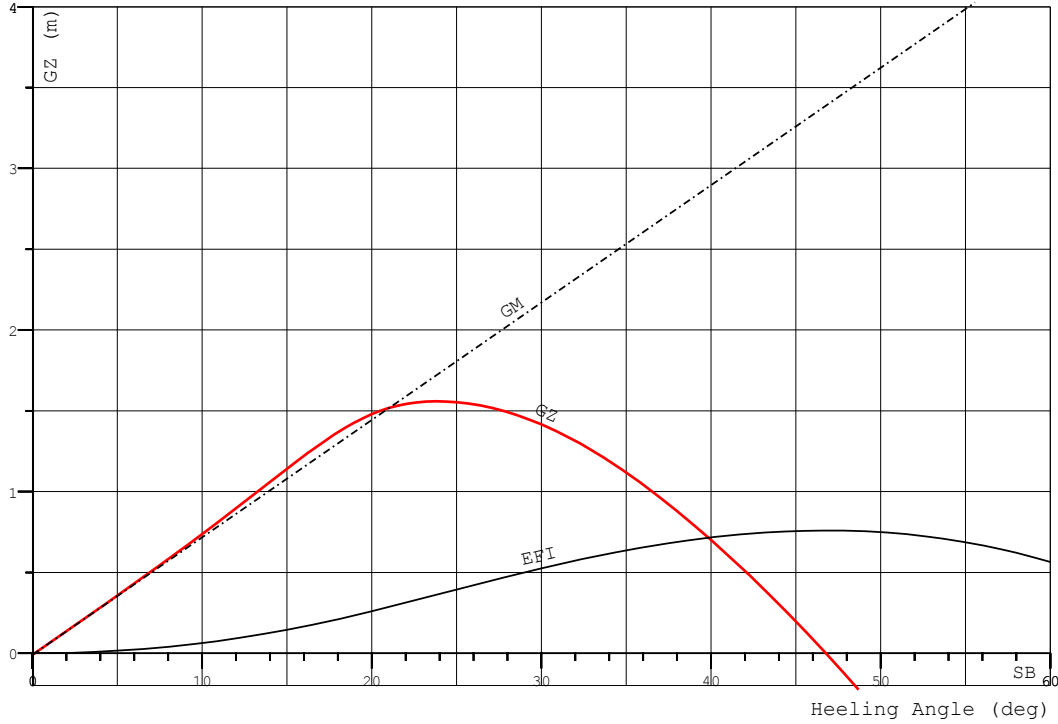

STABILITY CURVE

DISP	RHO	KMT	GM0	XCG	YCG	ZCG					
13429.1	1.025	17.96	4.16	70.27	0.01	13.80					
ANGLE	0.0	1.0	5.0	10.0	15.0	20.0	25.0	30.0	40.0	50.0	60.0
MS	-0.010	-0.010	-0.007	0.014	0.064	0.056	-0.206	-0.666	-1.975	-3.573	-5.356
GM0*SINF	0.000	0.073	0.363	0.723	1.077	1.424	1.759	2.081	2.676	3.189	3.605
DGZ	0.000	0.000	0.000	0.000	0.000	0.000	0.000	0.000	0.000	0.000	0.000
GZ	-0.010	0.063	0.356	0.737	1.141	1.479	1.553	1.415	0.700	-0.384	-1.751
EFI	0.000	0.000	0.015	0.063	0.144	0.260	0.394	0.525	0.717	0.749	0.565

IMO Stability Criteria

Criterion	Description	Required	Attained	UNIT	Status
MW.POSMAX	Max GZ should occur at >25 deg.	25.000	23.879	deg	NOT MET
V.AREA15-30	Area depending on GZ curve top	0.061	0.364	mrاد	OK
MW.AREA40	Area of GZ curve up to 40 deg.	0.090	0.717	mrاد	OK
MW.AREA40-DF.	Area of GZ curve between 0 and Dfld	0.090	0.759	mrاد	OK
MW.AREA3040	Area of GZ curve between 30 and 40 de.	0.030	0.192	mrاد	OK
MW.AREA30-DF.	Area of GZ between 30 deg. and Dfld	0.030	0.234	mrاد	OK
MW.MAZGZ	Max gz. >=0.2 m at heel>30 deg	0.200	1.415	m	OK
MW.MINGM	Min GM >0.15 m	0.150	4.162	m	OK
IMOWEATHER	IMO weather criterion	1.000	0.842		NOT MET

Warning: Stability Criteria NOT MET !!!

LOADING CONDITION: LIGHSHIPLONGSTRENGTH

BUNKER and MISCELLANEOUS TANKS:

Tank ID	Tank name	Dens t/m3	Fill %	Weight t	LCG m	TCG m	VCG m	FSM tm	GMcor m
-----									
Er tanks									
R773	73 WASTE OIL TANK CL	0.850	0.0	0.0	42.93	-3.38	0.74	0	0.000
R774	74 TO DRAIN TK SB	0.850	0.0	0.0	112.74	3.75	0.62	0	0.000
R775	75 TO STORAGE TK PS	0.850	0.0	0.0	112.74	-3.75	0.62	0	0.000
R776	76 DIRTY WATER TK SB	0.850	0.0	0.0	109.43	3.58	0.63	0	0.000
R777	77 DIRTY OIL TK PS	0.850	0.0	0.0	109.83	-3.58	0.62	0	0.000
R778	78 IFO/GO OVERFLOW .	0.850	0.0	0.0	105.72	0.00	0.62	0	0.000
R779	79 FUEL OIL LEAK.TK.	0.850	0.0	0.0	103.77	0.00	0.62	0	0.000
R780	80 CW DRAIN TK CL	0.850	0.0	0.0	102.99	0.00	0.62	0	0.000
-----									
Total of Er tanks				0.0	0.00	0.00	0.00	0	0.000
Fresh water									
R442	42 FRESH WATER TK 1.	1.000	0.0	0.0	118.75	10.15	7.36	0	0.000
R443	43 FRESH WATER TK 1.	1.000	0.0	0.0	118.75	-10.15	7.36	0	0.000
R444	44 FRESH WATER TK 2.	1.000	0.0	0.0	114.22	10.69	6.73	0	0.000
R445	45 FRESH WATER TK 2.	1.000	0.0	0.0	114.22	-10.69	6.73	0	0.000
-----									
Total of Fresh water				0.0	0.00	0.00	0.00	0	0.000
Hydraulic oil									
R784	84 HO STORAGE TK TH.	0.900	0.0	0.0	125.61	7.50	9.70	0	0.000
R797	97 HO STORAGE TK PI.	0.900	0.0	0.0	63.99	10.51	10.05	0	0.000
-----									
Total of Hydraulic oil				0.0	0.00	0.00	0.00	0	0.000
Heeling water									
R114	14 WB TK 8 SB	1.000	0.0	0.0	13.87	11.85	8.27	0	0.000
R115	15 WB TK 8 PS	1.000	0.0	0.0	13.87	-11.85	8.27	0	0.000
R666	66 HEELING TK SB	1.000	0.0	0.0	23.18	11.88	7.31	0	0.000
R667	67 HEELING TK PS	1.000	0.0	0.0	23.18	-11.88	7.31	0	0.000
R670	STABILIZER TANK 1 A.	1.000	0.0	0.0	86.22	0.00	23.40	0	0.000
R671	STABILIZER TANK 2 F.	1.000	0.0	0.0	90.90	0.00	23.40	0	0.000
-----									
Total of Heeling water				0.0	0.00	0.00	0.00	0	0.000
Int. fuel oil									
R334	34 IFO TK 1 SB	0.991	0.0	0.0	80.52	11.72	3.33	0	0.000
R335	35 IFO TK 1 PS	0.991	0.0	0.0	80.52	-11.72	3.33	0	0.000
R336	36 IFO TK 2 SB	0.991	0.0	0.0	69.84	11.98	3.39	0	0.000
R337	37 IFO TK 2 PS	0.991	0.0	0.0	69.84	-11.98	3.39	0	0.000
R338	38 IFO TK 3 SB	0.991	0.0	0.0	53.35	12.11	3.39	0	0.000
R339	39 IFO TK 3 PS	0.991	0.0	0.0	57.82	-12.11	3.39	0	0.000
R560	60 IFO SETTTL.TK SB	0.991	0.0	0.0	109.23	11.43	6.97	0	0.000
R561	61 IFO SETTTL.TK PS	0.991	0.0	0.0	109.23	-11.43	6.97	0	0.000
R562	62 IFO SERV.TK SB	0.991	0.0	0.0	109.23	11.22	9.69	0	0.000
R563	63 IFO SERV.TK PS	0.991	0.0	0.0	109.23	-11.22	9.69	0	0.000
-----									
Total of Int. fuel oil				0.0	0.00	0.00	0.00	0	0.000

Tank ID	Tank name	Dens t/m3	Fill %	Weight t	LCG m	TCG m	VCG m	FSM tm	GMcor m
-----									
Lubricating oil									
R559	59 LUB. OIL TANK PS	0.900	0.0	0.0	89.69	-12.34	28.10	0	0.000
R772	72 LO STORAGE TANK .	0.900	0.0	0.0	110.96	0.72	6.40	0	0.000
R781	81 LO STORAGE TANK .	0.900	0.0	0.0	110.01	-0.75	6.40	0	0.000
R782	82 LO REN TANK CL	0.900	0.0	0.0	108.84	0.38	6.40	0	0.000
R783	83 LO STORAGE TK TH.	0.900	0.0	0.0	125.61	4.88	9.70	0	0.000
R785	85 LO STORAGE TK PI.	0.900	0.0	0.0	-2.70	6.38	9.77	0	0.000
R786	86 LO STOR TK THRUS.	0.900	0.0	0.0	-2.70	8.25	9.77	0	0.000
-----									
Total of Lubricating oil				0.0	0.00	0.00	0.00	0	0.000
Marine gas oil									
R220	20 MGO TK 1 SB	0.890	0.0	0.0	89.96	3.64	0.64	0	0.000
R221	21 MGO TK 1 PS	0.890	0.0	0.0	89.96	-3.64	0.64	0	0.000
R222	22 MGO TK 2 SB	0.890	0.0	0.0	90.15	10.39	0.65	0	0.000
R223	23 MGO TK 2 PS	0.890	0.0	0.0	90.15	-10.39	0.65	0	0.000
R226	26 MGO TK 4 SB	0.890	0.0	0.0	49.95	3.38	0.74	0	0.000
R227	27 MGO TK 4 PS	0.890	0.0	0.0	49.95	-3.38	0.74	0	0.000
R228	28 MGO TK 5 SB	0.890	0.0	0.0	97.97	11.51	6.49	0	0.000
R229	29 MGO TK 5 PS	0.890	0.0	0.0	97.97	-11.51	6.49	0	0.000
R230	30 MGO TK 6 SB	0.890	0.0	0.0	88.56	11.60	3.28	0	0.000
R231	31 MGO TK 6 PS	0.890	0.0	0.0	88.56	-11.60	3.28	0	0.000
R554	54 MGO SETTTL.TK SB	0.890	0.0	0.0	105.72	11.23	10.05	0	0.000
R555	55 MGO SETTTL.TK PS	0.890	0.0	0.0	105.72	-11.23	10.05	0	0.000
R556	56 MGO SERV.TK SB	0.890	0.0	0.0	103.77	11.23	10.05	0	0.000
R557	57 MGO SERV.TK PS	0.890	0.0	0.0	103.77	-11.23	10.05	0	0.000
R558	58 MGO TK EMERG. DI.	0.890	0.0	0.0	92.07	-7.60	28.00	0	0.000
-----									
Total of Marine gas oil				0.0	0.00	0.00	0.00	0	0.000
Tech. fresh water									
R448	48 TECH.FW TK 1 SB	1.000	0.0	0.0	69.84	10.40	0.75	0	0.000
R449	49 TECH.FW TK 1 PS	1.000	0.0	0.0	69.84	-10.40	0.75	0	0.000
R450	50 TECH.FW TK 2 SB	1.000	0.0	0.0	53.40	10.39	0.75	0	0.000
R451	51 TECH.FW TK 2 PS	1.000	0.0	0.0	53.24	-10.39	0.75	0	0.000
-----									
Total of Tech. fresh water				0.0	0.00	0.00	0.00	0	0.000
-----									
TOTAL				0.0	0.00	0.00	0.00	0	0.000

LOADING CONDITION: LIGHSHIPLONGSTRENGTH

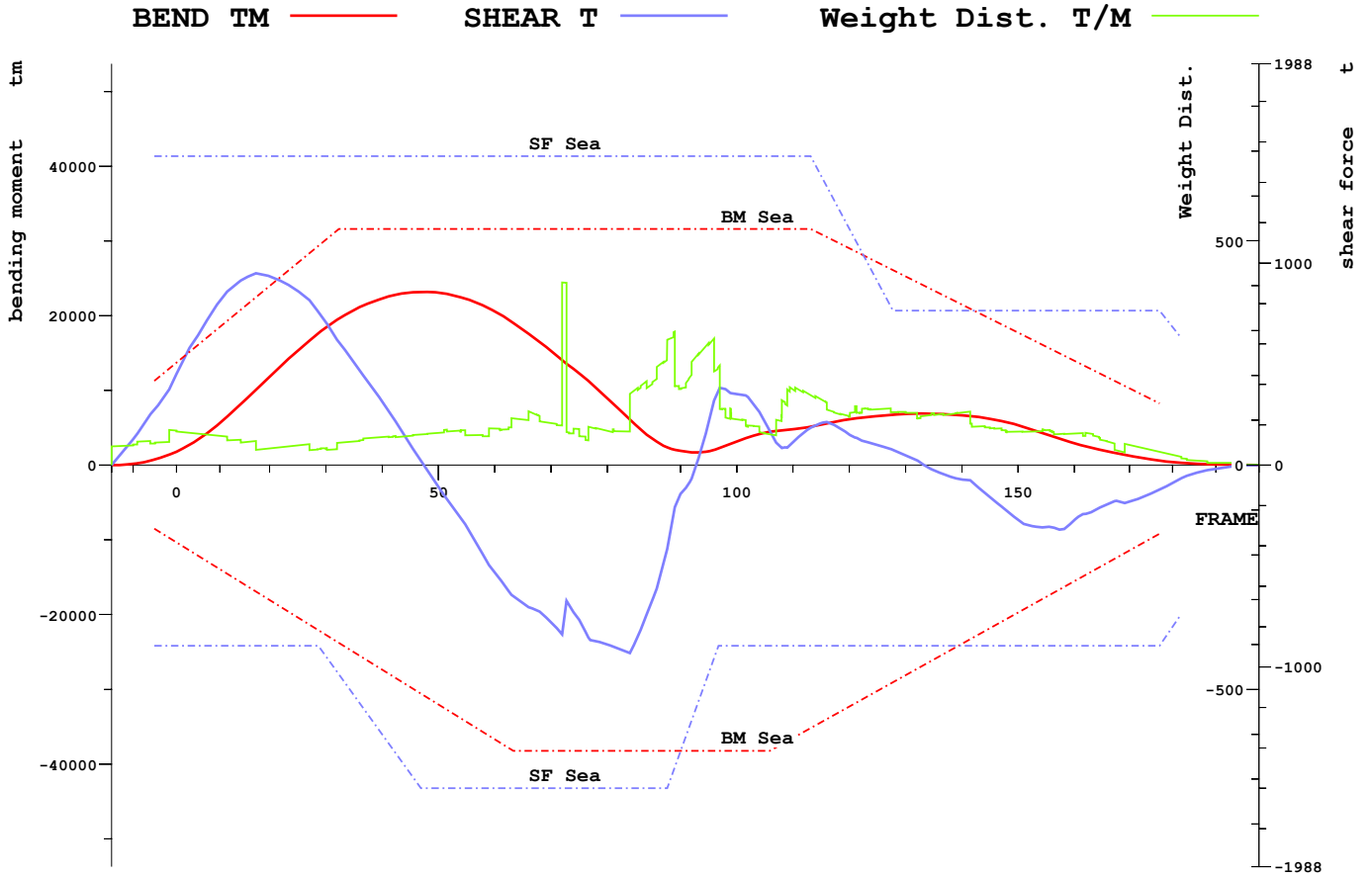

		POSITION:	X	FRAME
SHEAR FORCE (MIN)	-931.0 t		62.8 m	84
SHEAR FORCE (MAX)	950.6 t		11.0 m	18
MAX. REL. SHEAR FORCE	62.2 %		62.8 m	84
SAGGING MOMENT	-0.6 tm		-8.8 m	-15
HOGGING MOMENT	23192.9 tm		34.3 m	47
MAX. REL. SAGGING MOMENT	0.0 %		-8.8 m	-15
MAX. REL. HOGGING MOMENT	73.4 %		34.3 m	47

Strength limit: Sea

X m	Frame #	SHEAR t	SFmin t	SFmax t	SFrel %	BEND tm	BMmin tm	BMmax tm	BMrel %
-3.1	-5	274	-894	1529	17.9	741	-8495	11286	6.6
2.6	4	623	-894	1529	40.8	3204	-11893	15800	20.3
14.7	22	908	-894	1529	59.4	13476	-19113	25393	53.1
19.7	29	759	-894	1529	49.6	17656	-22086	29343	60.2
22.5	32	610	-1036	1529	39.9	19580	-23785	31600	62.0
33.9	47	22	-1600	1529	1.4	23179	-30581	31600	73.3
46.7	63	-648	-1600	1529	40.5	19021	-38226	31600	60.2
56.6	76	-822	-1600	1529	51.4	11618	-38226	31600	36.8
60.9	82	-903	-1600	1529	56.5	7856	-38226	31600	24.9
68.0	88	-414	-1600	1529	25.9	2381	-38226	31600	7.5
75.1	97	367	-894	1529	24.0	2252	-38226	31600	7.1
82.2	106	171	-894	1529	11.2	4458	-38226	31600	14.1
87.9	113	185	-894	1529	12.1	5138	-35168	31600	16.3
99.3	128	76	-894	765	10.0	6749	-29052	26105	25.9
110.7	142	-96	-894	765	10.7	6489	-22936	20609	31.5
117.8	151	-294	-894	765	32.9	5013	-19113	17174	29.2
120.6	155	-306	-894	765	34.2	4131	-17584	15800	26.1
136.2	177	-121	-894	765	13.6	593	-9174	8244	7.2

LOADING CONDITION: LIGHSHIPLONGSTRENGTH

Tank ID	Tank name	Dens t/m3	Fill %	Weight t	LCG m	TCG m	VCG m	FSM tm	GMcorr m
-----									
Fire fighting									
RDECK10	Deck 10 (Bridgedec.)	1.000	0.0	0.0	99.14	0.00	31.25	0	0.000
RDECK11	Deck 11 (Topdeck)	1.000	0.0	0.0	99.70	0.00	34.33	0	0.000
RDECK6	Deck 6	1.000	0.0	0.0	110.16	0.00	19.00	0	0.000
RDECK7	Deck 7 (C-deck)	1.000	0.0	0.0	109.98	-0.00	22.00	0	0.000
RDECK8	Deck 8 (B-deck)	1.000	0.0	0.0	109.81	0.00	25.00	0	0.000
RDECK9	Deck 9 (A-deck)	1.000	0.0	0.0	105.35	0.00	28.00	0	0.000
REMGEN	EMERG. GEN ROOM	1.000	0.0	0.0	88.28	-9.99	28.00	0	0.000
R885	ROV HANGAR	1.000	0.0	0.0	88.56	0.00	16.70	0	0.000
R888	COFFERDAM	1.000	0.0	0.0	88.07	0.00	24.66	0	0.000
R889	WORKSHOPS	1.000	0.0	0.0	81.54	0.00	13.50	0	0.000
-----									
Total of Fire fighting				0.0	0.00	0.00	0.00	0	0.000
Flood water									
R1006	SKEG	1.025	0.0	0.0	9.82	0.00	0.79	0	0.000
R668	68 VOID 12	1.025	0.0	0.0	68.11	0.00	0.74	0	0.000
R669	69 VOID 11	1.025	0.0	0.0	78.02	0.00	12.00	0	0.000
R7851	VOID UNDER BHTHUBE	1.025	0.0	0.0	124.05	0.00	0.30	0	0.000
R787	87 VOID 1	1.025	0.0	0.0	127.86	0.00	1.55	0	0.000
R788	88 VOID 2	1.025	0.0	0.0	119.90	0.00	1.31	0	0.000
R789	89 VOID 3	1.025	0.0	0.0	109.26	0.00	0.66	0	0.000
R791	91 VOID 5	1.025	0.0	0.0	23.28	0.00	0.97	0	0.000
R792	92 VOID 6	1.025	0.0	0.0	13.90	0.00	5.16	0	0.000
R793	93 VOID 7	1.025	0.0	0.0	4.13	0.00	6.38	0	0.000
R794	94 VOID 8	1.025	0.0	0.0	112.36	11.12	10.24	0	0.000
R795	95 VOID 9	1.025	0.0	0.0	112.36	-11.12	10.24	0	0.000
R796	96 VOID 10 PS	1.025	0.0	0.0	35.91	-11.98	10.55	0	0.000
R801	THRUSTERROOM 4	1.025	0.0	0.0	8.10	-6.89	9.96	0	0.000
R802	THRUSTERROOM 5	1.025	0.0	0.0	8.10	6.89	9.96	0	0.000
R803	THRUSTERROOM 6	1.025	0.0	0.0	-0.83	-0.14	10.07	0	0.000
R804	PIPELAY WORKSHOP SB	1.025	0.0	0.0	36.23	10.29	10.55	0	0.000
R805	PIPELAY STORES	1.025	0.0	0.0	65.79	7.43	10.55	0	0.000
R806	HI PAP RM SB	1.025	0.0	0.0	61.65	10.50	6.25	0	0.000
R807	HI PAP RM PS	1.025	0.0	0.0	61.65	-10.50	6.25	0	0.000
R808	HI PAP RM SPARE	1.025	0.0	0.0	47.61	10.50	6.25	0	0.000
R809	NITROGEN BOTTLES R.	1.025	0.0	0.0	57.82	-12.11	8.90	0	0.000
R810	PIPELAY TRANSF. RO.	1.025	0.0	0.0	67.79	-9.22	10.55	0	0.000
R811	CAROUSSEL HOLD	1.025	0.0	0.0	38.49	-0.74	6.94	0	0.000
R812	WINCH ROOM	1.025	0.0	0.0	68.58	0.00	5.04	0	0.000
R870	ALLEWAY FWD SB	1.025	0.0	0.0	86.00	11.24	10.26	0	0.000
R871	ALLEWAY FWD PS	1.025	0.0	0.0	86.00	-11.24	10.26	0	0.000
R876	BTH ROOM 1	1.025	0.0	0.0	128.52	-0.00	7.56	0	0.000
R877	BTH ROOM 2	1.025	0.0	0.0	123.54	-0.06	7.42	0	0.000
R878	BTH ROOM 3	1.025	0.0	0.0	118.98	0.00	6.89	0	0.000
R879	ECR RM	1.025	0.0	0.0	87.39	0.00	10.05	0	0.000
R880	ELEVATOR ROOM	1.025	0.0	0.0	106.78	0.00	8.93	0	0.000
R881	ER SB	1.025	0.0	0.0	96.60	4.75	8.48	0	0.000
R882	ER PS	1.025	0.0	0.0	96.60	-4.74	8.44	0	0.000
R883	BOSUN STORE	1.025	0.0	0.0	135.69	0.00	14.83	0	0.000
R884	FORECASTLE	1.025	0.0	0.0	112.99	0.00	14.53	0	0.000
R886	CHAIN LOCKER SB	1.025	0.0	0.0	133.86	1.13	14.50	0	0.000

Tank ID	Tank name	Dens t/m3	Fill %	Weight t	LCG m	TCG m	VCG m	FSM tm	GMcorr m
R887	CHAIN LOCKER PS	1.025	0.0	0.0	133.86	-1.13	14.50	0	0.000
Total of Flood water				0.0	0.00	0.00	0.00	0	0.000
TOTAL				0.0	0.00	0.00	0.00	0	0.000



**APPENDIX D - NEUTRAL AXIS AND MOMENT OF  
INERTIA FOR WEBFRAME**

## Appendix D

This appendix calculates the distance ( $Z_{NA}$ ) from baseline to the neutral axis, moment of inertia ( $I_y$ ) and first moment of inertia ( $q_y$ ) for the selected webframe.

### D.1: References

/1/ DNV (2013). Rules for Classification of Ships, Part 3 Chapter 1. *Hull Structural Design, Ships with Length 100 Metres and Above*. Det Norske Veritas, Norway

### D.2: Abbreviations and Symbols

A	-	Area per element/webframe
d	-	Distance from webframes neutral axis to mass centre for element
$I_{y,i}$	-	Moment of inertia per element/webframe around y-axis
$I_{y,i}$	-	Moment of inertia per element/webframe around y-axis
Width	-	Width of element
Thk	-	Thickness of element
$Z_{NA}$	-	Distance from baseline to neutral axis
$z_0$	-	Reuired midship section modulus with accordance to DNV
$z_L$	-	Lever per element (distance from vessels baseline to mass centre for element)

### D.3: Inputs From Appendix H

$A_{HP140x7} := 12.4\text{cm}^2$	$I_{HP140x7.y\_axis} := 3.80\text{cm}^4$
$A_{HP160x8} := 16.2\text{cm}^2$	$I_{HP160x8.y\_axis} := 6.55\text{cm}^4$
	$I_{HP160x8.x\_axis} := 411.00\text{cm}^4$
$A_{HP180x8} := 18.9\text{cm}^2$	$I_{HP180x8.y\_axis} := 9.90\text{cm}^4$
$A_{HP200x9} := 23.6\text{cm}^2$	$I_{HP200x9.y\_axis} := 15.76\text{cm}^4$

$$A_{\text{HP220x10}} := 29.0\text{cm}^2 \quad I_{\text{HP220x10.x\_axis}} := 1400.00\text{cm}^4$$

$$I_{\text{HP220x10.y\_axis}} := 23.89\text{cm}^4$$

$$A_{\text{HP240x11}} := 34.9\text{cm}^2 \quad I_{\text{HP240x11.y\_axis}} := 34.81\text{cm}^4$$

$$A_{\text{HP260x11}} := 38.7\text{cm}^2 \quad I_{\text{HP260x11.x\_axis}} := 2610.00\text{cm}^4$$

$$I_{\text{HP260x11.y\_axis}} := 45.90\text{cm}^4$$

#### **D.4: Summary of Estimated Data**

Area of Webframe ( $A_{\text{webframe}}$ ):	$A_{\text{webframe}} = 3.83\text{m}^2$
Vertical distance from baseline to Neutral axis ( $Z_{\text{NA}}$ ):	$Z_{\text{NA}} := 7.69\text{m}$
Moment of Inertia for webframe ( $I_{y\_webframe}$ ):	$I_{y\_webframe} = 95.72\text{m}^4$
First moment of inertia for upper part ( $q_{y\_aboveB}$ ):	$q_{y\_aboveB} = 7.70\text{m}^3$

#### **D.5: Notation**

Due to symmetry, only portside (half of the webframe) are evaluated in section D6. Hence, it is required to multiply the values in D7-D10 with 2 to obtain values for the entire webframe.

**D.6: Computing  $Z_i$ ,  $I_{i,y}$  and  $q_{i,y}$  for Each Element in the Webframe****D.6.1: Plate Elements*****Bottom plate:***

$$\text{Width}_{\text{bo.plate}} := 13.13\text{m} \quad A_{\text{bo.plate}} := 0.1707\text{m}^2 \quad z_{\text{bo.plate}} := 0.007\text{m}$$

$$\text{Thk}_{\text{bo.plate}} := 0.013\text{m} \quad d_{\text{bo.plate}} := Z_{\text{NA}} - z_{\text{bo.plate}} = 7.683\text{m}$$

$$I_{\text{bo.plate}} := \left( \frac{\text{Width}_{\text{bo.plate}} \cdot \text{Thk}_{\text{bo.plate}}^3}{12} \right) + \left( A_{\text{bo.plate}} \cdot d_{\text{bo.plate}}^2 \right) = 10.076\text{m}^4$$

$$q_{\text{bo.plate}} := A_{\text{bo.plate}} \cdot d_{\text{bo.plate}} = 1.311 \cdot \text{m}^3$$

***Inner bottom plate:***

$$\text{Width}_{\text{i.bo.plate}} := 14.2\text{m} \quad A_{\text{i.bo.plate}} := 0.1562\text{m}^2 \quad z_{\text{i.bo.plate}} := 1.470\text{m}$$

$$\text{Thk}_{\text{i.bo.plate}} := 0.011\text{m} \quad d_{\text{i.bo.plate}} := Z_{\text{NA}} - z_{\text{i.bo.plate}} = 6.22\text{m}$$

$$I_{\text{i.bo.plate}} := \left( \frac{\text{Width}_{\text{i.bo.plate}} \cdot \text{Thk}_{\text{i.bo.plate}}^3}{12} \right) + \left( A_{\text{i.bo.plate}} \cdot d_{\text{i.bo.plate}}^2 \right) = 6.043\text{m}^4$$

$$q_{\text{i.bo.plate}} := A_{\text{i.bo.plate}} \cdot d_{\text{i.bo.plate}} = 0.972 \cdot \text{m}^3$$

**Bilge plate:**

$$\text{Width}_{\text{bi.plate}} := 1.825\text{m}$$

$$A_{\text{bi.plate}} := 0.0292\text{m}^2$$

$$z_{\text{bi.plate}} := 0.738\text{m}$$

$$\text{Thk}_{\text{bi.plate}} := 0.016\text{m}$$

$$d_{\text{bi.plate}} := Z_{\text{NA}} - z_{\text{bi.plate}} = 6.952\text{m}$$

$$I_{\text{bi.plate}} := \left( \frac{\text{Width}_{\text{bi.plate}} \cdot \text{Thk}_{\text{bi.plate}}^3}{12} \right) + \left( A_{\text{bi.plate}} \cdot d_{\text{bi.plate}}^2 \right) = 1.411\text{m}^4$$

$$q_{\text{bi.plate}} := A_{\text{bi.plate}} \cdot d_{\text{bi.plate}} = 0.203 \cdot \text{m}^3$$

**Side plates:***Plate 1:*

$$\text{Width}_{\text{si.plate1}} := 0.013\text{m}$$

$$A_{\text{si.plate1}} := 0.0497\text{m}^2$$

$$z_{\text{si.plate1}} := 4.125\text{m}$$

$$\text{Thk}_{\text{si.plate1}} := 3.825\text{m}$$

$$d_{\text{si.plate1}} := Z_{\text{NA}} - z_{\text{si.plate1}} = 3.565\text{m}$$

$$I_{\text{si.plate1}} := \left( \frac{\text{Width}_{\text{si.plate1}} \cdot \text{Thk}_{\text{si.plate1}}^3}{12} \right) + \left( A_{\text{si.plate1}} \cdot d_{\text{si.plate1}}^2 \right) = 0.692\text{m}^4$$

$$q_{\text{si.plate1}} := A_{\text{si.plate1}} \cdot d_{\text{si.plate1}} = 0.177 \cdot \text{m}^3$$

*Plate 2:*

$$\text{Width}_{\text{si.plate2}} := 0.012\text{m}$$

$$A_{\text{si.plate2}} := 0.0396\text{m}^2$$

$$z_{\text{si.plate2}} := 6.950\text{m}$$

$$\text{Thk}_{\text{si.plate2}} := 3.300\text{m}$$

$$d_{\text{si.plate2}} := Z_{\text{NA}} - z_{\text{si.plate2}} = 0.74\text{m}$$

$$I_{\text{si.plate2}} := \left( \frac{\text{Width}_{\text{si.plate2}} \cdot \text{Thk}_{\text{si.plate2}}^3}{12} \right) + \left( A_{\text{si.plate2}} \cdot d_{\text{si.plate2}}^2 \right) = 0.058\text{m}^4$$

$$q_{\text{si.plate2}} := A_{\text{si.plate2}} \cdot d_{\text{si.plate2}} = 0.029 \cdot \text{m}^3$$

*Plate 3:*       $\text{Width}_{\text{si.plate3}} := 0.011\text{m}$        $A_{\text{si.plate3}} := 0.0396\text{m}^2$        $z_{\text{si.plate3}} := 10.160\text{m}$

$\text{Thk}_{\text{si.plate3}} := 3.120\text{m}$        $d_{\text{si.plate3}} := z_{\text{si.plate3}} - Z_{\text{NA}} = 2.47\text{ m}$

$$I_{\text{si.plate3}} := \left( \frac{\text{Width}_{\text{si.plate3}} \cdot \text{Thk}_{\text{si.plate3}}^3}{12} \right) + \left( A_{\text{si.plate3}} \cdot d_{\text{si.plate3}}^2 \right) = 0.269\text{ m}^4$$

$$q_{\text{si.plate3}} := A_{\text{si.plate3}} \cdot d_{\text{si.plate3}} = 0.098 \cdot \text{m}^3$$

***Sheer strake plate:***

$\text{Width}_{\text{sh.plate}} := 0.018\text{m}$        $A_{\text{sh.plate}} := 0.0140\text{m}^2$        $z_{\text{sh.plate}} := 12.110\text{m}$

$\text{Thk}_{\text{sh.plate}} := 0.780\text{m}$        $d_{\text{sh.plate}} := z_{\text{sh.plate}} - Z_{\text{NA}} = 4.42\text{ m}$

$$I_{\text{sh.plate}} := \left( \frac{\text{Width}_{\text{sh.plate}} \cdot \text{Thk}_{\text{sh.plate}}^3}{12} \right) + \left( A_{\text{sh.plate}} \cdot d_{\text{sh.plate}}^2 \right) = 0.274\text{ m}^4$$

$$q_{\text{sh.plate}} := A_{\text{sh.plate}} \cdot d_{\text{sh.plate}} = 0.062 \cdot \text{m}^3$$

***Deck plate:***

$\text{Width}_{\text{de.plate}} := 14.200\text{m}$        $A_{\text{de.plate}} := 0.3550\text{m}^2$        $z_{\text{de.plate}} := 12.488\text{m}$

$\text{Thk}_{\text{de.plate}} := 0.025\text{m}$        $d_{\text{de.plate}} := z_{\text{de.plate}} - Z_{\text{NA}} = 4.798\text{ m}$

$$I_{\text{de.plate}} := \left( \frac{\text{Width}_{\text{de.plate}} \cdot \text{Thk}_{\text{de.plate}}^3}{12} \right) + \left( A_{\text{de.plate}} \cdot d_{\text{de.plate}}^2 \right) = 8.172\text{ m}^4$$

$$q_{\text{de.plate}} := A_{\text{de.plate}} \cdot d_{\text{de.plate}} = 1.703 \cdot \text{m}^3$$

**Inner deck plate:**

$$\text{Width}_{i.d.plate} := 14.200\text{m} \quad A_{i.d.plate} := 0.426\text{m}^2 \quad z_{i.d.plate} := 11.705\text{m}$$

$$\text{Thk}_{i.d.plate} := 0.030\text{m} \quad d_{i.d.plate} := z_{i.d.plate} - Z_{NA} = 4.015\text{m}$$

$$I_{i.d.plate} := \left( \frac{\text{Width}_{i.d.plate} \cdot \text{Thk}_{i.d.plate}^3}{12} \right) + \left( A_{i.d.plate} \cdot d_{i.d.plate}^2 \right) = 6.867\text{m}^4$$

$$q_{i.d.plate} := A_{i.d.plate} \cdot d_{i.d.plate} = 1.71 \cdot \text{m}^3$$

**Longitudinal bulkhead plates:**

$$\text{Plate 1:} \quad \text{Width}_{l.bhd.plate1} := 0.011\text{mm} \quad A_{l.bhd.plate1} := 0.0421\text{m}^2 \quad z_{l.bhd.plate1} := 4.125\text{m}$$

$$\text{Thk}_{l.bhd.plate1} := 3.825\text{m} \quad d_{l.bhd.plate1} := Z_{NA} - z_{l.bhd.plate1} = 3.565\text{m}$$

$$I_{l.bhd.plate1} := \left( \frac{\text{Width}_{l.bhd.plate1} \cdot \text{Thk}_{l.bhd.plate1}^3}{12} \right) + \left( A_{l.bhd.plate1} \cdot d_{l.bhd.plate1}^2 \right) = 0.535\text{m}^4$$

$$q_{l.bhd.plate1} := A_{l.bhd.plate1} \cdot d_{l.bhd.plate1} = 0.15 \cdot \text{m}^3$$

$$\text{Plate 2:} \quad \text{Width}_{l.bhd.plate2} := 0.009\text{m} \quad A_{l.bhd.plate2} := 0.0297\text{m}^2 \quad z_{l.bhd.plate2} := 6.950\text{m}$$

$$\text{Thk}_{l.bhd.plate2} := 3.300\text{m} \quad d_{l.bhd.plate2} := Z_{NA} - z_{l.bhd.plate2} = 0.74\text{m}$$

$$I_{l.bhd.plate2} := \left( \frac{\text{Width}_{l.bhd.plate2} \cdot \text{Thk}_{l.bhd.plate2}^3}{12} \right) + \left( A_{l.bhd.plate2} \cdot d_{l.bhd.plate2}^2 \right) = 0.043\text{m}^4$$

$$q_{l.bhd.plate2} := A_{l.bhd.plate2} \cdot d_{l.bhd.plate2} = 0.022 \cdot \text{m}^3$$

*Plate 3:*     $\text{Width}_{\text{l.bhd.plate3}} := 0.020\text{m}$      $A_{\text{l.bhd.plate3}} := 0.0624\text{m}^2$      $z_{\text{l.bhd.plate3}} := 10.160\text{m}$   
                   $\text{Thk}_{\text{l.bhd.plate3}} := 3.120\text{m}$      $d_{\text{l.bhd.plate3}} := z_{\text{l.bhd.plate3}} - Z_{\text{NA}} = 2.47\text{m}$

$$I_{\text{l.bhd.plate3}} := \left( \frac{\text{Width}_{\text{l.bhd.plate3}} \cdot \text{Thk}_{\text{l.bhd.plate3}}^3}{12} \right) + \left( A_{\text{l.bhd.plate3}} \cdot d_{\text{l.bhd.plate3}}^2 \right) = 0.431\text{m}^4$$

$$q_{\text{l.bhd.plate3}} := A_{\text{l.bhd.plate3}} \cdot d_{\text{l.bhd.plate3}} = 0.154 \cdot \text{m}^3$$

***Centre bulkhead plate:***

$\text{Width}_{\text{ctr.bhd.plate}} := 0.020\text{m}$      $A_{\text{ctr.bhd.plate}} := 0.0295\text{m}^2$      $z_{\text{ctr.bhd.plate}} := 0.738\text{m}$   
                   $\text{Thk}_{\text{ctr.bhd.plate}} := 1.475\text{m}$      $d_{\text{ctr.bhd.plate}} := Z_{\text{NA}} - z_{\text{ctr.bhd.plate}} = 6.952\text{m}$

$$I_{\text{ctr.bhd.plate}} := \left( \frac{\text{Width}_{\text{ctr.bhd.plate}} \cdot \text{Thk}_{\text{ctr.bhd.plate}}^3}{12} \right) \dots = 1.431\text{m}^4$$

$$+ \left( A_{\text{ctr.bhd.plate}} \cdot d_{\text{ctr.bhd.plate}}^2 \right)$$

$$q_{\text{ctr.bhd.plate}} := A_{\text{ctr.bhd.plate}} \cdot d_{\text{ctr.bhd.plate}} = 0.205 \cdot \text{m}^3$$

***Side stringer plates:***

*Plate 1:*     $\text{Width}_{\text{s.string.plate1}} := 4.552\text{m}$      $A_{\text{s.string.plate1}} := 0.0455\text{m}^2$      $z_{\text{s.string.plate1}} := 5.295\text{m}$   
                   $\text{Thk}_{\text{s.string.plate1}} := 0.010\text{m}$      $d_{\text{s.string.plate1}} := Z_{\text{NA}} - z_{\text{s.string.plate1}} = 2.395\text{m}$

$$I_{\text{s.string.plate1}} := \left( \frac{\text{Width}_{\text{s.string.plate1}} \cdot \text{Thk}_{\text{s.string.plate1}}^3}{12} \right) + \left( A_{\text{s.string.plate1}} \cdot d_{\text{s.string.plate1}}^2 \right) = 0.261\text{m}^4$$

$$q_{\text{s.string.plate1}} := A_{\text{s.string.plate1}} \cdot d_{\text{s.string.plate1}} = 0.109 \cdot \text{m}^3$$



$$\text{Plate 2: } \text{Width}_{\text{s.string.plate2}} := 5.950\text{m} \quad A_{\text{s.string.plate2}} := 0.0893\text{m}^2 \quad z_{\text{s.string.plate2}} := 8.593\text{m}$$

$$\text{Thk}_{\text{s.string.plate2}} := 0.015\text{m} \quad d_{\text{s.string.plate2}} := z_{\text{s.string.plate2}} - Z_{\text{NA}} = 0.903\text{m}$$

$$I_{\text{s.string.plate2}} := \left( \frac{\text{Width}_{\text{s.string.plate2}} \cdot \text{Thk}_{\text{s.string.plate2}}^3}{12} \right) + \left( A_{\text{s.string.plate2}} \cdot d_{\text{s.string.plate2}}^2 \right) = 0.073\text{m}^4$$

$$q_{\text{s.string.plate2}} := A_{\text{s.string.plate2}} \cdot d_{\text{s.string.plate2}} = 0.081 \cdot \text{m}^3$$

**Bottom girder plates:**

(5 plates)

$$\text{Width}_{\text{bo.gdr.plate}} := 0.016\text{m} \quad A_{\text{bo.gdr.plate}} := 0.0236\text{m}^2 \quad z_{\text{bo.gdr.plate}} := 0.738\text{m}$$

$$\text{Thk}_{\text{bo.gdr.plate}} := 1.475\text{m} \quad d_{\text{bo.gdr.plate}} := Z_{\text{NA}} - z_{\text{bo.gdr.plate}} = 6.952\text{m}$$

$$I_{\text{bo.gdr.plates}} := 5 \left( \frac{\text{Width}_{\text{bo.gdr.plate}} \cdot \text{Thk}_{\text{bo.gdr.plate}}^3}{12} \right) + \left( A_{\text{bo.gdr.plate}} \cdot d_{\text{bo.gdr.plate}}^2 \right) \dots = 1.162\text{m}^4$$

$$q_{\text{bo.gdr.plates}} := 5 \left( A_{\text{bo.gdr.plate}} \cdot d_{\text{bo.gdr.plate}} \right) = 0.82 \cdot \text{m}^3$$

**Deck girder plates:**

(3.5 plates)

$$\text{Width}_{\text{dk.gdr.plate}} := 0.016\text{m} \quad A_{\text{dk.gdr.plate}} := 0.0125\text{m}^2 \quad z_{\text{dk.gdr.plate}} := 12.110\text{m}$$

$$\text{Thk}_{\text{dk.gdr.plate}} := 0.780\text{m} \quad d_{\text{dk.gdr.plate}} := z_{\text{dk.gdr.plate}} - Z_{\text{NA}} = 4.42\text{m}$$

$$I_{\text{dk.gdr.plates}} := 3.5 \left( \frac{\text{Width}_{\text{dk.gdr.plate}} \cdot \text{Thk}_{\text{dk.gdr.plate}}^3}{12} \right) + \left( A_{\text{dk.gdr.plate}} \cdot d_{\text{dk.gdr.plate}}^2 \right) \dots = 0.246\text{m}^4$$

$$q_{\text{dk.gdr.plates}} := 3.5 \left( A_{\text{dk.gdr.plate}} \cdot d_{\text{dk.gdr.plate}} \right) = 0.193 \cdot \text{m}^3$$

**D.6.2: Stiffeners****Bottom longitudinal stiffeners:**

$$\text{HP220x10} \quad z_{\text{btm.long}} := 0.134\text{m} \quad d_{\text{btm.long}} := Z_{\text{NA}} - z_{\text{btm.long}} = 7.556\text{m}$$

(7 stiffeners)

$$I_{\text{btm.long}} := 7 \left[ I_{\text{HP220x10.x\_axis}} + \left( A_{\text{HP220x10}} \cdot d_{\text{btm.long}}^2 \right) \right] = 1.159\text{m}^4$$

$$q_{\text{btm.long}} := 7 \left( A_{\text{HP220x10}} \cdot d_{\text{btm.long}} \right) = 0.153 \cdot \text{m}^3$$

**Inner bottom longitudinal stiffeners:**

$$\text{HP220x10} \quad z_{\text{i.b.long1}} := 1.341\text{m} \quad d_{\text{i.b.long1}} := Z_{\text{NA}} - z_{\text{i.b.long1}} = 6.349\text{m}$$

(8 stiffeners)

$$I_{\text{i.b.long1}} := 8 \left[ I_{\text{HP220x10.x\_axis}} + \left( A_{\text{HP220x10}} \cdot d_{\text{i.b.long1}}^2 \right) \right] = 0.935\text{m}^4$$

$$q_{\text{i.b.long1}} := 8 \left( A_{\text{HP220x10}} \cdot d_{\text{i.b.long1}} \right) = 0.147 \cdot \text{m}^3$$

HP180x8  
(1 stiffener)

$$z_{i.b.long2} := 0.730\text{m}$$

$$d_{i.b.long2} := Z_{NA} - z_{i.b.long2} = 6.96\text{ m}$$

$$I_{i.b.long2} := I_{HP180x8.y\_axis} + \left( A_{HP180x8} \cdot d_{i.b.long2}^2 \right) = 0.092\text{ m}^4$$

$$q_{i.b.long2} := 1 \left( A_{HP180x8} \cdot d_{i.b.long2} \right) = 0.013 \cdot \text{m}^3$$

**Side longitudinal stiffeners:**

HP240x11  
(2 stiffeners)

$$z_{s.long.1} := 2.230\text{m}$$

$$d_{s.long.1} := Z_{NA} - z_{s.long.1} = 5.46\text{ m}$$

$$I_{s.long.1} := 2 \left[ I_{HP240x11.y\_axis} + \left( A_{HP240x11} \cdot d_{s.long.1}^2 \right) \right] = 0.208\text{ m}^4$$

$$q_{s.long.1} := 2 \left( A_{HP240x11} \cdot d_{s.long.1} \right) = 0.038 \cdot \text{m}^3$$

HP240x11  
(2 stiffeners)

$$z_{s.long.2} := 3.995\text{m}$$

$$d_{s.long.2} := Z_{NA} - z_{s.long.2} = 3.695\text{ m}$$

$$I_{s.long.2} := 2 \left[ I_{HP240x11.y\_axis} + \left( A_{HP240x11} \cdot d_{s.long.2}^2 \right) \right] = 0.095\text{ m}^4$$

$$q_{s.long.2} := 2 \left( A_{HP240x11} \cdot d_{s.long.2} \right) = 0.026 \cdot \text{m}^3$$

HP240x11  
(2 stiffeners)

$$z_{s.long.3} := 3.760\text{m}$$

$$d_{s.long.3} := Z_{NA} - z_{s.long.3} = 3.93\text{ m}$$

$$I_{s.long.3} := 2 \left[ I_{HP240x11.y\_axis} + \left( A_{HP240x11} \cdot d_{s.long.3}^2 \right) \right] = 0.108\text{ m}^4$$

$$q_{s.long.3} := 2 \left( A_{HP240x11} \cdot d_{s.long.3} \right) = 0.027 \cdot \text{m}^3$$

*HP240x11*  
(2 stiffeners)

$$z_{s,long,4} := 4.525\text{m}$$

$$d_{s,long,4} := Z_{NA} - z_{s,long,4} = 3.165\text{ m}$$

$$I_{s,long,4} := 2 \left[ I_{HP240x11,y\_axis} + \left( A_{HP240x11} \cdot d_{s,long,4}^2 \right) \right] = 0.07\text{ m}^4$$

$$q_{s,long,4} := 2 \left( A_{HP240x11} \cdot d_{s,long,4} \right) = 0.022 \cdot \text{m}^3$$

*HP220x10*  
(2 stiffeners)

$$z_{s,long,5} := 6.116\text{m}$$

$$d_{s,long,5} := Z_{NA} - z_{s,long,5} = 1.574\text{ m}$$

$$I_{s,long,5} := 2 \left[ I_{HP220x10,y\_axis} + \left( A_{HP220x10} \cdot d_{s,long,5}^2 \right) \right] = 0.014\text{ m}^4$$

$$q_{s,long,5} := 2 \left( A_{HP220x10} \cdot d_{s,long,5} \right) = 9.129 \times 10^{-3} \cdot \text{m}^3$$

*HP220x10*  
(2 stiffeners)

$$z_{s,long,6} := 6.941\text{m}$$

$$d_{s,long,6} := Z_{NA} - z_{s,long,6} = 0.749\text{ m}$$

$$I_{s,long,6} := 2 \left[ I_{HP220x10,y\_axis} + \left( A_{HP220x10} \cdot d_{s,long,6}^2 \right) \right] = 3.254 \times 10^{-3}\text{ m}^4$$

$$q_{s,long,6} := 2 \left( A_{HP220x10} \cdot d_{s,long,6} \right) = 4.344 \times 10^{-3} \cdot \text{m}^3$$

*HP200x9*  
(2 stiffeners)

$$z_{s,long,7} := 7.767\text{m}$$

$$d_{s,long,7} := z_{s,long,7} - Z_{NA} = 0.077\text{ m}$$

$$I_{s,long,7} := 2 \left[ I_{HP200x9,y\_axis} + \left( A_{HP200x9} \cdot d_{s,long,7}^2 \right) \right] = 2.83 \times 10^{-5}\text{ m}^4$$

$$q_{s,long,7} := 2 \left( A_{HP200x9} \cdot d_{s,long,7} \right) = 3.634 \times 10^{-4} \cdot \text{m}^3$$

$$\begin{array}{lll} \text{HP180x8} & z_{s,\text{long},8} := 9.373\text{m} & d_{s,\text{long},8} := z_{s,\text{long},8} - Z_{\text{NA}} = 1.683\text{ m} \\ (2 \text{ stiffeners}) & & \end{array}$$

$$I_{s,\text{long},8} := 2 \left[ I_{\text{HP180x8},y\_axis} + \left( A_{\text{HP180x8}} \cdot d_{s,\text{long},8}^2 \right) \right] = 0.011 \text{ m}^4$$

$$q_{s,\text{long},8} := 2 \left( A_{\text{HP180x8}} \cdot d_{s,\text{long},8} \right) = 6.362 \times 10^{-3} \cdot \text{m}^3$$

$$\begin{array}{lll} \text{HP160x8} & z_{s,\text{long},9} := 10.153\text{m} & d_{s,\text{long},9} := z_{s,\text{long},9} - Z_{\text{NA}} = 2.463\text{ m} \\ (2 \text{ stiffeners}) & & \end{array}$$

$$I_{s,\text{long},9} := 2 \left[ I_{\text{HP160x8},y\_axis} + \left( A_{\text{HP160x8}} \cdot d_{s,\text{long},9}^2 \right) \right] = 0.02 \text{ m}^4$$

$$q_{s,\text{long},9} := 2 \left( A_{\text{HP160x8}} \cdot d_{s,\text{long},9} \right) = 7.98 \times 10^{-3} \cdot \text{m}^3$$

$$\begin{array}{lll} \text{HP140x7} & z_{s,\text{long},10} := 10.934\text{m} & d_{s,\text{long},10} := z_{s,\text{long},10} - Z_{\text{NA}} = 3.244\text{ m} \\ (2 \text{ stiffeners}) & & \end{array}$$

$$I_{s,\text{long},10} := 2 \left[ I_{\text{HP140x7},y\_axis} + \left( A_{\text{HP140x7}} \cdot d_{s,\text{long},10}^2 \right) \right] = 0.026 \text{ m}^4$$

$$q_{s,\text{long},10} := 2 \left( A_{\text{HP140x7}} \cdot d_{s,\text{long},10} \right) = 8.045 \times 10^{-3} \cdot \text{m}^3$$

**Deck longitudinal stiffeners:**

$$\begin{array}{lll} \text{HP260x11} & z_{\text{dk},\text{long}} := 12.340\text{m} & d_{\text{dk},\text{long}} := z_{\text{dk},\text{long}} - Z_{\text{NA}} = 4.65\text{ m} \\ (15.5 \text{ stiffeners}) & & \end{array}$$

$$I_{\text{dk},\text{long}} := 15.5 \left[ I_{\text{HP260x11},x\_axis} + \left( A_{\text{HP260x11}} \cdot d_{\text{dk},\text{long}}^2 \right) \right] = 1.297 \text{ m}^4$$

$$q_{\text{dk},\text{long}} := 15.5 \left( A_{\text{HP260x11}} \cdot d_{\text{dk},\text{long}} \right) = 0.279 \cdot \text{m}^3$$

**Stringer stiffeners:**

$$\begin{array}{lll} \text{HP160x8} & z_{\text{string1}} := 8.505\text{m} & d_{\text{string1}} := z_{\text{string1}} - Z_{\text{NA}} = 0.815\text{ m} \\ (6 \text{ stiffeners}) & & \end{array}$$

$$I_{\text{string1}} := 6 \left[ I_{\text{HP160x8.x\_axis}} + \left( A_{\text{HP160x8}} \cdot d_{\text{string1}}^2 \right) \right] = 6.481 \times 10^{-3} \text{ m}^4$$

$$q_{\text{string1}} := 6 \left( A_{\text{HP160x8}} \cdot d_{\text{string1}} \right) = 7.922 \times 10^{-3} \cdot \text{m}^3$$

$$\begin{array}{lll} \text{HP160x8} & z_{\text{string2}} := 5.205\text{m} & d_{\text{string2}} := Z_{\text{NA}} - z_{\text{string2}} = 2.485\text{ m} \\ (5 \text{ stiffeners}) & & \end{array}$$

$$I_{\text{string2}} := 5 \left[ I_{\text{HP160x8.x\_axis}} + \left( A_{\text{HP160x8}} \cdot d_{\text{string2}}^2 \right) \right] = 0.05 \text{ m}^4$$

$$q_{\text{string2}} := 5 \left( A_{\text{HP160x8}} \cdot d_{\text{string2}} \right) = 0.02 \cdot \text{m}^3$$

**D.7: Area of Webframe**

$$\begin{aligned} A_{\text{half\_webframe}} := & A_{\text{bo.plate}} + A_{\text{i.bo.plate}} + A_{\text{bi.plate}} + A_{\text{si.plate1}} + A_{\text{si.plate2}} + A_{\text{si.plate3}} + A_{\text{sh.plate}} \dots \\ & + A_{\text{de.plate}} + A_{\text{i.d.plate}} + A_{\text{l.bhd.plate1}} + A_{\text{l.bhd.plate2}} + A_{\text{l.bhd.plate3}} \dots \\ & + A_{\text{ctr.bhd.plate}} + A_{\text{s.string.plate1}} + A_{\text{s.string.plate2}} + 5A_{\text{bo.gdr.plate}} + 3.5 \cdot A_{\text{dk.gdr.plate}} \dots \\ & + 7A_{\text{HP220x10}} + 8A_{\text{HP220x10}} + A_{\text{HP180x8}} + 8A_{\text{HP240x11}} + 4A_{\text{HP220x10}} \dots \\ & + 2A_{\text{HP200x9}} + 2A_{\text{HP180x8}} + 2A_{\text{HP160x8}} + 2A_{\text{HP140x7}} + 15.5A_{\text{HP260x11}} \dots \\ & + 11A_{\text{HP160x8}} \end{aligned}$$

**Result:**

$$A_{\text{webframe}} := 2 \cdot A_{\text{half\_webframe}} = 3.834 \text{ m}^2$$

**D.8: Vertical Distance from Baseline to Neutral Axis ( $Z_{NA}$ ) for Webframe****D.8.1: Based on the numerical approach**

Estimating vertical distance from baseline to neutral axis by:

$$Z_{NA} = \frac{A_{izi\_tot}}{A_{tot}} \quad \text{Eq. \{3.9\}}$$

where:

$$\begin{aligned} A_{izi\_half\_webframe} := & \left( A_{bo.plate} \cdot z_{bo.plate} \right) + \left( A_{i.bo.plate} \cdot z_{i.bo.plate} \right) + \left( A_{bi.plate} \cdot z_{bi.plate} \right) \dots \\ & + \left( A_{si.plate1} \cdot z_{si.plate1} \right) + \left( A_{si.plate2} \cdot z_{si.plate2} \right) + \left( A_{si.plate3} \cdot z_{si.plate3} \right) \dots \\ & + \left( A_{sh.plate} \cdot z_{sh.plate} \right) + \left( A_{de.plate} \cdot z_{de.plate} \right) + \left( A_{i.d.plate} \cdot z_{i.d.plate} \right) \dots \\ & + \left( A_{l.bhd.plate1} \cdot z_{l.bhd.plate1} \right) + \left( A_{l.bhd.plate2} \cdot z_{l.bhd.plate2} \right) \dots \\ & + \left( A_{l.bhd.plate3} \cdot z_{l.bhd.plate3} \right) + \left( A_{ctr.bhd.plate} \cdot z_{ctr.bhd.plate} \right) \dots \\ & + \left( A_{s.string.plate1} \cdot z_{s.string.plate1} \right) + \left( A_{s.string.plate2} \cdot z_{s.string.plate2} \right) \dots \\ & + 5 \left( A_{bo.gdr.plate} \cdot z_{bo.gdr.plate} \right) + 3.5 \left( A_{dk.gdr.plate} \cdot z_{dk.gdr.plate} \right) \dots \\ & + 7 \left( A_{HP220x10} \cdot z_{btm.long} \right) + 8 \left( A_{HP220x10} \cdot z_{i.b.long1} \right) \dots \\ & + \left( A_{HP180x8} \cdot z_{i.b.long2} \right) + 2 \left( A_{HP240x11} \cdot z_{s.long.1} \right) \dots \\ & + 2 \left( A_{HP240x11} \cdot z_{s.long.2} \right) + 2 \left( A_{HP240x11} \cdot z_{s.long.3} \right) \dots \\ & + 2 \left( A_{HP240x11} \cdot z_{s.long.4} \right) + 2 \left( A_{HP220x10} \cdot z_{s.long.5} \right) + 2 \left( A_{HP220x10} \cdot z_{s.long.6} \right) \dots \\ & + 2 \left( A_{HP200x9} \cdot z_{s.long.7} \right) + 2 \left( A_{HP180x8} \cdot z_{s.long.8} \right) + 2 \left( A_{HP160x8} \cdot z_{s.long.9} \right) \dots \\ & + 2 \left( A_{HP140x7} \cdot z_{s.long.10} \right) + 15.5 \left( A_{HP260x11} \cdot z_{dk.long} \right) + 6 \left( A_{HP160x8} \cdot z_{string1} \right) \dots \\ & + 5 \left( A_{HP160x8} \cdot z_{string2} \right) \end{aligned}$$

$$A_{izi\_tot} := 2 \cdot A_{izi\_half\_webframe}$$

**Result:**

$$Y_{webframe} := \frac{A_{izi\_tot}}{A_{webframe}} = 7.612 \text{ m}$$

**D.8.2: AutoCADs estimation of  $Z_{NA}$**

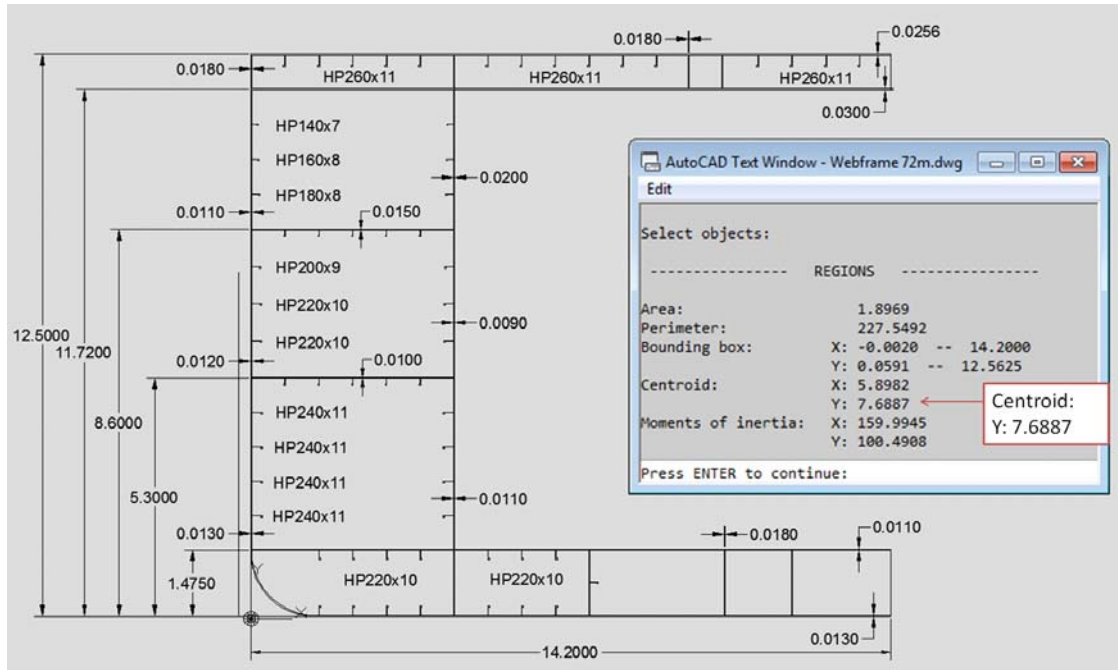

$Z_{AutoCAD} := 7.69m$



### D.9: Moment of Inertia for Webframe

#### D.9.1: Based on the numerical approach

The total moment of inertia is found by summing up all  $I_i$ . Eq. {3.10}

$$\begin{aligned}
 I_{y\_half\_webframe} := & I_{bo,plate} + I_{ibo,plate} + I_{bi,plate} + I_{si,plate1} + I_{si,plate2} + I_{si,plate3} + I_{sh,plate} + I_{de,plate} \dots \\
 & + I_{id,plate} + I_{l,bhd,plate1} + I_{l,bhd,plate2} + I_{l,bhd,plate3} + I_{ctr,bhd,plate} + I_{s,string,plate1} \dots \\
 & + I_{s,string,plate2} + 5I_{bo,gdr,plates} + 3.5I_{dk,gdr,plates} + I_{btm,long} + I_{i,b,long1} \dots \\
 & + I_{i,b,long2} + I_{s,long,1} + I_{s,long,2} + I_{s,long,3} + I_{s,long,4} + I_{s,long,5} + I_{s,long,6} \dots \\
 & + I_{s,long,7} + I_{s,long,8} + I_{s,long,9} + I_{s,long,10} + I_{dk,long} + I_{string1} + I_{string2}
 \end{aligned}$$

**Result:**

$$I_{y\_webframe} := 2 \cdot I_{y\_half\_webframe} = 94.812 \text{ m}^4$$

#### D.9.2: AutoCADs estimation of ( $I_y$ )

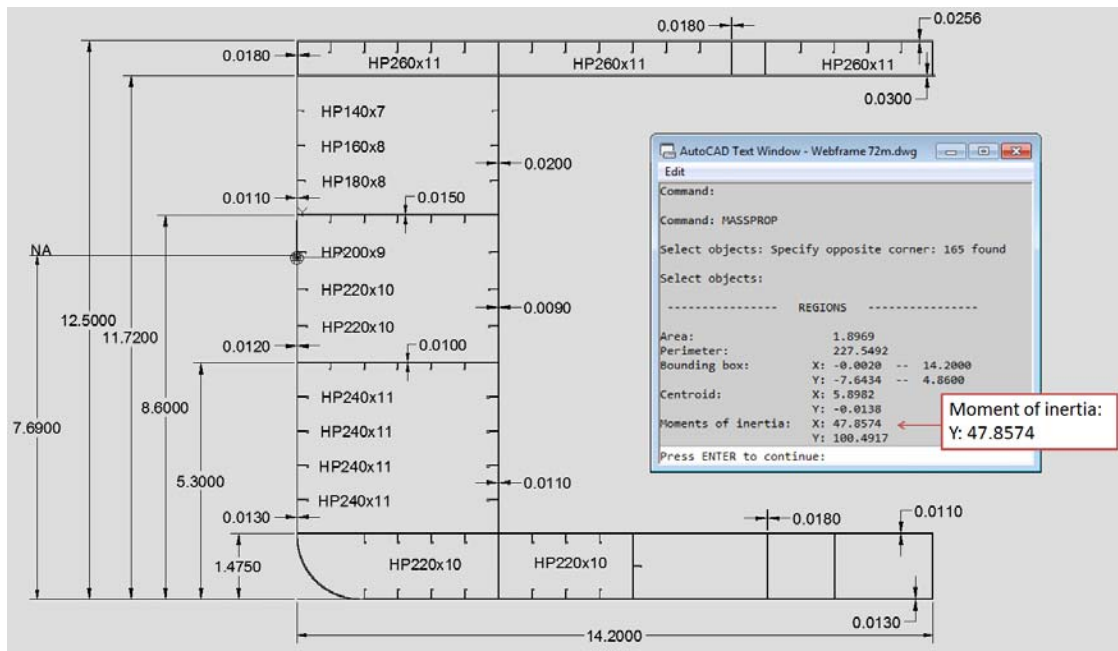

$$I_{y,AutoCAD} := 47.86 \text{ m}^4 \cdot 2 = 95.72 \text{ m}^4$$

The moment of inertia from hand calculations are coherent with the AutoCAD. The 0.01% difference might be because the bilge keel is simplified in the hand calculation.

**D.10: First Moment of Inertia for Areas Above Point B at plate (see Figure 2-10)****B.10.1 Elements included*****Side plates***

$$A_{0.25.si.plate3} := 0.780m \cdot 0.011m = 8.58 \times 10^{-3} m^2$$

$$d_{0.25.si.plate3} := 11.330m - Z_{NA} = 3.64 \cdot m$$

$$q_{0.25.si.plate3} := A_{0.25.si.plate3} \cdot d_{0.25.si.plate3} = 0.031 \cdot m^3$$

***Longitudinal bulkhead plate:***

$$A_{0.25.l.bhd.plate3} := 0.0156m^2$$

$$d_{0.25.l.bhd.plate3} := 11.330m - Z_{NA} = 3.64 m$$

$$q_{0.25.l.bhd.plate3} := A_{0.25.l.bhd.plate3} \cdot d_{0.25.l.bhd.plate3} = 0.057 \cdot m^3$$

***Sheer strake plate:***

$$q_{sh.plate} = 0.062 \cdot m^3$$

***Deck plate:***

$$q_{de.plate} = 1.703 \cdot m^3$$

***Inner deck plate:***

$$q_{id.plate} = 1.71 \cdot m^3$$

***Deck longitudinal stiffeners:***

$$q_{dk.long} = 0.279 \cdot m^3$$

***Side longitudinal stiffener:***

$$q_{s.long.10} = 8.045 \times 10^{-3} \cdot m^3$$

**Result:**

$$q_{y\_half\_aboveB} := q_{0.25.si.plate3} + q_{sh.plate} + q_{de.plate} + q_{id.plate} + q_{0.25.l.bhd.plate3} \dots \\ + q_{s.long.10} + q_{dk.long}$$

$$q_{y\_aboveB} := 2(q_{y\_half\_aboveB}) = 7.701 \cdot m^3$$

**D.11: Additional information****D.11.1: Required minimum Moment of Inertia with Accordance to DNV /1/**

DNV states that the midship section moment of inertia about the transverse neutral axis shall not be less than /1/:

$$I_{\text{required}} = 3 \cdot C_W \cdot L_p^3 \cdot B \cdot (C_B + 0.7)$$

From Appendix F:

$$L_p := 142.1$$

$$B := 28.4$$

$$C_W := 8.766$$

$$C_B := 0.797$$

$$I_{\text{required}} := 3 \cdot C_W \cdot (L_p)^3 \cdot B \cdot (C_B + 0.7) = 3.208 \times 10^4 \text{ cm}^4$$

$$I_{\text{required}} = 32.08 \text{ m}^4$$

$$I_{\text{webframe}} > I_{\text{required}}$$

Calculated moment of inertia corresponds with AutoCAD and also satisfies the requirement by DNV.

**D.11.2: Required Midship Section Modulus with According to DNV /1/**

$$C_{WO} := 10.75 - \left[ \frac{(300 - L_p)}{100} \right]^{\frac{3}{2}} = 8.766 \quad f_1 := 1.35$$

$$z_0 := \left( \frac{C_{WO}}{f_1} \right) \cdot L_p^2 \cdot B \cdot (C_B + 0.7) = 5.574 \times 10^6 \text{ cm}^3$$

Calculated second moment of inertia corresponds with AutoCAD and also satisfies the requirement by DNV.

## **APPENDIX E - STRESSES ON SIDE PLATE**

## APPENDIX E

The purpose of this appendix is to estimate stresses on the side plate. Moment of inertia is found from AutoCAD and hand calculations (Appendix D). Bending moments and shear forces are found from DNV (in Appendix A), from *Seven Seas* Stability Booklet (Appendix B) and Seven Seas NAPA software (Appendix C).

### **E.1: References**

/1/ DNV (2013). Rules for Classification of Ships, Part 3 Chapter 1. *Hull Structural Design, Ships with Length 100 metres and above*. Det Norske Veritas, Norway.

/2/ Beer, F. P., Johnston, Jr. E. R., DeWolf, J.T., Mazurek, D.F. (2009). *Mechanics of Materials Fifth Edition (SI Units)*. McGraw-Hill Companies, New York.

/3/ DNV (2002). Recommended Practice, DNV-RP-C102. *Structural Design of Offshore Ships*. Det Norske Veritas, Norway.

/4/ IHC Merwede (2009). *Stability Booklet, Flex-lay Construction Vessel*. Yard number 710, IMO No. 9 38 47 60. The Netherlands

### **E.2: Symbols**

$\sigma_x$	-	Longitudinal bending stress
$\tau$	-	Shear stress
$t$	-	Thickness
$I_y$	-	Moment of inertia around y-axis
$q_y$	-	First moment of inertia around y-axis
$Q$	-	Shear force
$M$	-	Bending moment

### **E.3: Assumptions**

- 1) The loads are applied in a plane of symmetry of the member.
- 2) Buckling stress is neglected.

**E.4: The Webframe and the Location of Plate**

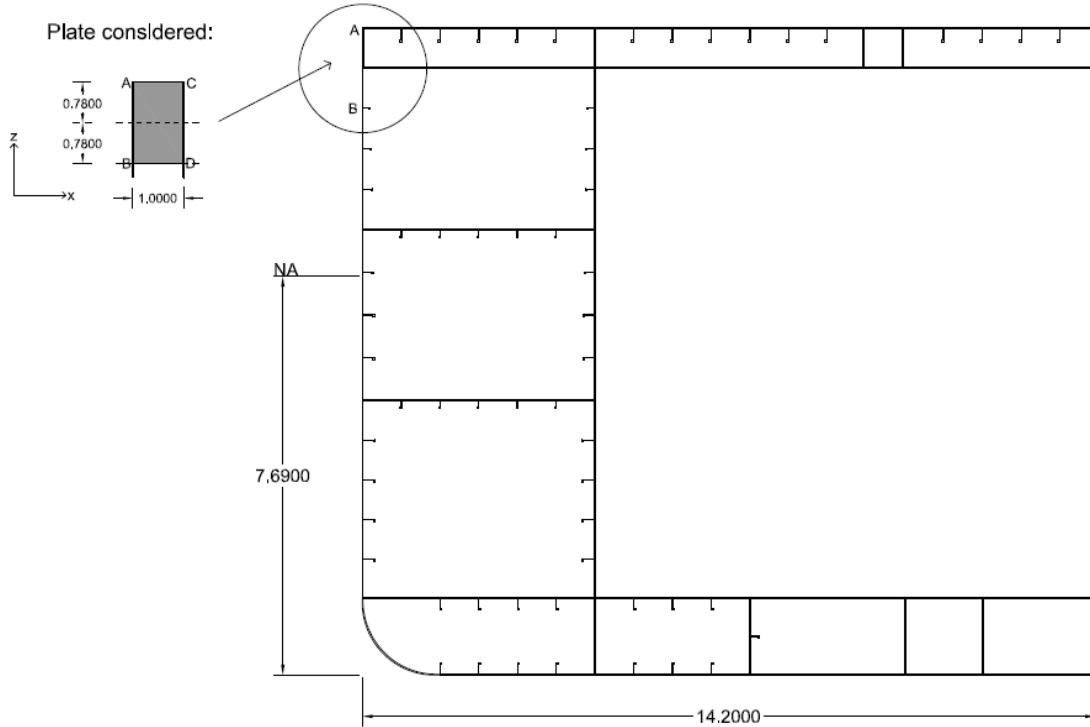

**E.5: Bending Moments and Shear Forces**

**E.5.1: Inputs From Appendix A**

Max. Allowable Load Condition	Bending Moment, M [kNm]		Shear Force, Q [kN]	
	<i>Sagging</i>	<i>Hogging</i>	<i>Sagging</i>	<i>Hogging</i>
<i>Still-water</i>	-489000	55500	-13800	15600
<i>Vertical wave in sheltered condition</i>	-244100	224500	-3300	3300
<i>Vertical wave in seagoing condition</i>	-488200	449000	-6600	6600
<i>Load combination 1</i>	-928500	980900	-21100	23400
<i>Load combination 2</i>	-1050000	1072000	-21300	23200

**E.5.2: Inputs From Appendix B**

Reading of from strength diagrams at 72m from AP.

Load Conditions, Stability Booklet	Bending Moment, M [kNm]	Shear Force, Q [kN]
Condition 1	-40000	1900
Condition 2	0	0
Condition 4	-131000	-2500
Condition 5	-6000	6200
Condition 6	0	-3700
Condition 7	-98000	0

**E.5.3: Inputs From Appendix C**

Reading of longitudinal strength diagram from Seven Seas NAPA software (Appendix C)

Load Conditions, NAPA	Bending Moment, M [kNm]	Shear Force, Q [kN]
Condition	-176600	8800

**E.6: Previously Estimated Data for Webframe****E.6.1: Inputs From Appendix D**

Vertical distance from baseline to neutral axis ( $Z_{NA}$ ):	$Z_{NA} := 7.69 \text{ m}$
Vertical distance from Neutral axis to uppmost deck: point B ( $Z_B$ ):	$Z_A := 4.81 \text{ m}$
Vertical distance from Neutral axis to point A ( $Z_A$ ):	$Z_B := 3.25 \text{ m}$
Moment of Inertia for webframe ( $I_{y\_webframe}$ ):	$I_y := 95.72 \text{ m}^4$
First moment of inertia for area above point B ( $q_{y\_upper.part}$ ):	$q_{y\_upper.part} := 7.70 \text{ m}^3$

### **E.7: Guidance**

"I<sub>y</sub>" and "Z<sub>NA</sub>" for webframe are estimated by AutoCAD and validated by hand calculations.

#### **Max. Allowable Load Condition**

Design bending moments and shear forces are computed with accordance to DNV rules /1/.

#### **Load condition, *Stability Booklet***

Bending moments and shear forces are read from the strength diagrams in the *Stability Booklet* /4/. The values in the strength diagrams apply to operations during which the significant wave height are expected not to exceed 3-4m /4/. Condition 1,2,4,5,6 and 7 from Booklet considered.

#### **Load condition from the NAPA software**

Longitudinal stability diagram retrieved from the *Seven Seas* crew. Vessel load condition: Lightship with a 400 tons deck load on AP area and a 200 tons deck load (structure on deck) at webframe 72m. Bending moment and shear forces are read from the strength diagram in Appendix C.

### **E.8: Bending Stresses**

#### **Euler-Bernoulli beam theory**

Longitudinal elastic stress in a webframe can be found by:

$$\sigma = \left( \frac{M}{I} \right) \cdot y \quad \text{Eq. \{3.12\}}$$



**E.8.1: Bending stress at Point A and C****E.8.1.1: Max. Allowable Load Condition** $M_{\text{sag}} :=$ 

	0
0	$-4.89 \cdot 10^4$
1	$-2.441 \cdot 10^5$
2	$-4.882 \cdot 10^5$
3	$-9.285 \cdot 10^5$
4	$-1.05 \cdot 10^6$

$$\sigma_{\text{sag},A} := \frac{M_{\text{sag}} \cdot Z_A \cdot (\text{kN} \cdot \text{m}^2)}{I_y \cdot (\text{m}^4)} = \begin{pmatrix} -2.457 \\ -12.266 \\ -24.532 \\ -46.658 \\ -52.763 \end{pmatrix} \cdot \text{MPa}$$

 $M_{\text{hog}} :=$ 

	0
0	$5.55 \cdot 10^4$
1	$2.245 \cdot 10^5$
2	$4.49 \cdot 10^5$
3	$9.809 \cdot 10^5$
4	$1.072 \cdot 10^6$

$$\sigma_{\text{hog},A} := \frac{M_{\text{hog}} \cdot Z_A \cdot (\text{kN} \cdot \text{m}^2)}{I_y \cdot (\text{m}^4)} = \begin{pmatrix} 2.789 \\ 11.281 \\ 22.562 \\ 49.291 \\ 53.869 \end{pmatrix} \cdot \text{MPa}$$

**E.8.1.2: Load condition, Stability Booklet** $M_{\text{booklet}} :=$ 

	0
0	$-4 \cdot 10^4$
1	0
2	$-1.31 \cdot 10^5$
3	$-6 \cdot 10^3$
4	0
5	$-9.8 \cdot 10^4$

$$\sigma_{\text{booklet},A} := \frac{M_{\text{booklet}} \cdot Z_A \cdot (\text{kN} \cdot \text{m}^2)}{I_y \cdot (\text{m}^4)} = \begin{pmatrix} -2.01 \\ 0 \\ -6.583 \\ -0.302 \\ 0 \\ -4.925 \end{pmatrix} \cdot \text{MPa}$$

**E.8.1.3: Load condition from the NAPA software** $M_{\text{NAPA}} := -176600 \text{ kNm}$ 

$$\sigma_{\text{NAPA},A} := \frac{M_{\text{NAPA}} \cdot Z_A \cdot (\text{kN} \cdot \text{m}^2)}{I_y \cdot (\text{m}^4)} = -8.874 \cdot \text{MPa}$$

**E.8.2: Bending Stresses at Point B and D****E.8.2.1: Max. Allowable Load Condition**

$$\sigma_{\text{sag.B}} := \frac{M_{\text{sag}} \cdot Z_B \cdot (\text{kN} \cdot \text{m}^2)}{I_y \cdot (\text{m}^4)} = \begin{pmatrix} -1.66 \\ -8.288 \\ -16.576 \\ -31.526 \\ -35.651 \end{pmatrix} \cdot \text{MPa}$$

$$\sigma_{\text{hog.B}} := \frac{M_{\text{hog}} \cdot Z_B \cdot (\text{kN} \cdot \text{m}^2)}{I_y \cdot (\text{m}^4)} = \begin{pmatrix} 1.884 \\ 7.622 \\ 15.245 \\ 33.305 \\ 36.398 \end{pmatrix} \cdot \text{MPa}$$

**E.8.2.2: Load condition, Stability Booklet**

$$\sigma_{\text{booklet.B}} := \frac{M_{\text{booklet}} \cdot Z_B \cdot (\text{kN} \cdot \text{m}^2)}{I_y \cdot (\text{m}^4)} = \begin{pmatrix} -1.358 \\ 0 \\ -4.448 \\ -0.204 \\ 0 \\ -3.327 \end{pmatrix} \cdot \text{MPa}$$

**E.8.2.3: Load condition from the NAPA software**

$$\sigma_{\text{NAPA.B}} := \frac{M_{\text{NAPA}} \cdot Z_B \cdot (\text{kN} \cdot \text{m}^2)}{I_y \cdot (\text{m}^4)} = -5.996 \cdot \text{MPa}$$

**E.9: Average Shearing Stresses Located at Plate**

The average shearing stress exerted on the element can be found by equation:

$$\tau = \frac{(V \cdot Q)}{I \cdot t} \quad \text{Eq. \{3.13\}}$$

The DNV /1/ specifies that when considering shear stress at strength deck the thickness shall not be less than:

$$t_{\text{ave}} = \frac{t_1 + t_2}{2} \quad t_1 := 0.018 \text{ m} \quad t_2 := 0.025 \text{ m}$$

$$t_{\text{ave}} := \frac{t_1 + t_2}{2} = 0.022 \text{ m} \quad \text{Eq. \{3.15\}}$$

**E.9.1: Max. Allowable Load Condition**

$Q_{\text{sag}} :=$

	0
0	$-1.38 \cdot 10^4$
1	$-3.3 \cdot 10^3$
2	$-6.6 \cdot 10^3$
3	$-2.11 \cdot 10^4$
4	$-2.13 \cdot 10^4$

$$\tau_{\text{sag}} := \frac{Q_{\text{sag}} \cdot q_{y\_upper.part} \cdot (\text{kN} \cdot \text{m}^3)}{I_y \cdot t_{\text{ave}} \cdot (\text{m}^4 \cdot \text{m})} = \begin{pmatrix} -51.633 \\ -12.347 \\ -24.694 \\ -78.946 \\ -79.695 \end{pmatrix} \cdot \text{MPa}$$

$Q_{\text{hog}} :=$

	0
0	$1.56 \cdot 10^4$
1	$3.3 \cdot 10^3$
2	$6.6 \cdot 10^3$
3	$2.34 \cdot 10^4$
4	$2.32 \cdot 10^4$

$$\tau_{\text{hog}} := \frac{Q_{\text{hog}} \cdot q_{y\_upper.part} \cdot (\text{kN} \cdot \text{m}^3)}{I_y \cdot t_{\text{ave}} \cdot (\text{m}^4 \cdot \text{m})} = \begin{pmatrix} 58.368 \\ 12.347 \\ 24.694 \\ 87.552 \\ 86.804 \end{pmatrix} \cdot \text{MPa}$$

**E.9.2: Load Condition, Stability Booklet** $V_{\text{booklet}} :=$ 

	0
0	$1.9 \cdot 10^3$
1	0
2	$-2.5 \cdot 10^3$
3	$6.2 \cdot 10^3$
4	$-3.7 \cdot 10^3$
5	0

$$\tau_{\text{booklet}} := \frac{V_{\text{booklet}} \cdot q_{y\_upper.part} \cdot (\text{kN} \cdot \text{m}^3)}{I_y \cdot t_{ave} \cdot (\text{m}^4 \cdot \text{m})} = \begin{pmatrix} 7.109 \\ 0 \\ -9.354 \\ 23.198 \\ -13.844 \\ 0 \end{pmatrix} \cdot \text{MPa}$$

**E.9.3: Load Condition from the NAPA Software** $Q_{\text{NAPA}} := 8800 \quad \text{kNm}$ 

$$\tau_{\text{NAPA}} := \frac{Q_{\text{NAPA}} \cdot q_{y\_upper.part} \cdot (\text{kN} \cdot \text{m}^3)}{I_y \cdot t_{ave} \cdot (\text{m}^4 \cdot \text{m})} = 32.925 \cdot \text{MPa}$$

## **APPENDIX F - SEA PRESSURE ON PLATE**

## APPENDIX F

This appendix estimates the sea pressure on *Seven Seas* side plate with accordance to the DNV approach (Section 3.2.5). The probability of exceedance is  $10^{-4}$  (approximately daily return period).

### **F.1: Referenses**

/1/ DNV (2013). Rules for classification of ships, part 3 chapter 1. Hull Structural Design, Ships with Length 100 metres and above.

/2/ IHC Merwede (2009). Stability Booklet, Flex-lay construction vessel. Yard number 710, IMO No. 9 38 47 60. The Netherlands

### **F.2: Vessel Data**

#### **F.2.1: Vessel Geometry /2/**

Length between perpendiculars ( $L_p$ ):	$L_p := 142.1 \text{ m}$
Greatest molded breadth of <i>Seven Seas</i> (B):	$B := 28.4 \text{ m}$
Mean molded summer draught ( $T_{\text{mean}}$ ):	$T_{\text{mean}} := 7.5 \text{ m}$
Vessel depth (D):	$D := 12.5 \text{ m}$
The horizontal distance from centre line to load point, distance from centroid of webframe to sideplate on portside ( $y_1$ ):	$y_1 := 12.4 \text{ m}$

#### **F.2.2: Parameters From DNV /1/ and Seven Seas Stability Booklet /2/**

Block coefficient ( $C_B$ ):	$C_B := 0.797 -$
Wave load coefficient ( $C_W$ ):	$C_W := 8.766 -$
Acceleration factor for the side (a):	$a := 1.0 -$
$k_f$ is defined as the smallest value of T and f:	$k_f := 5 -$

$$k_{s\_1} := 3 \cdot C_B + \frac{2.5}{\sqrt{C_B}} \quad \text{at AP and aft}$$

$$k_{s\_2} := 2 \quad \text{between } 0.2L \text{ and } 0.7L \text{ from AP}$$

$$k_{s\_3} := 3 \cdot C_B + \frac{4.0}{C_B} \quad \text{at FP and forward}$$

$$\text{Thus: } k_s := 2 \quad -$$

### F.2.3: Assumptions

- 1) - The waterline throughout the vessels length is assumed to be the same as the mean molded summer draught value.
- 2) - Block coefficient is assumed to not change throughout the vessel.

### F.3: Summary - The design Sea Pressure Acting on The Seven Seas Side ( $P_{sd}$ )

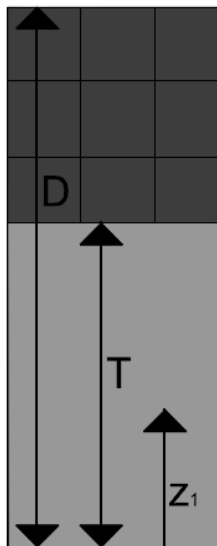

<i>Load point</i>	$z_1$ [m]	$p$ [kN/m <sup>2</sup> ]	$P_{sd}$ [MPa]
1.0(D-T)	12.5	16.7	0.02
0.8(D-T)	11.5	21.1	0.02
0.6(D-T)	10.5	25.5	0.03
0.4(D-T)	9.5	29.9	0.03
0.2(D-T)	8.5	34.3	0.03
Waterline	7.5	38.7	0.04
0.2T	6	51.9	0.05
0.4T	4.5	65.1	0.07
0.6T	3	78.3	0.08
0.8T	1.5	91.5	0.09
Baseline	0	104.7	0.1

<-- sea pressure of interest, located around sheer strake area

Figure f.1: An overview of the terms used in the summary of side shells. Created in AutoCAD

**F.4: Extrenal Sea Pressure Acting on *Seven Seas* Side**

Figure f.2 illustrates the basic meaning of terms used for the side.

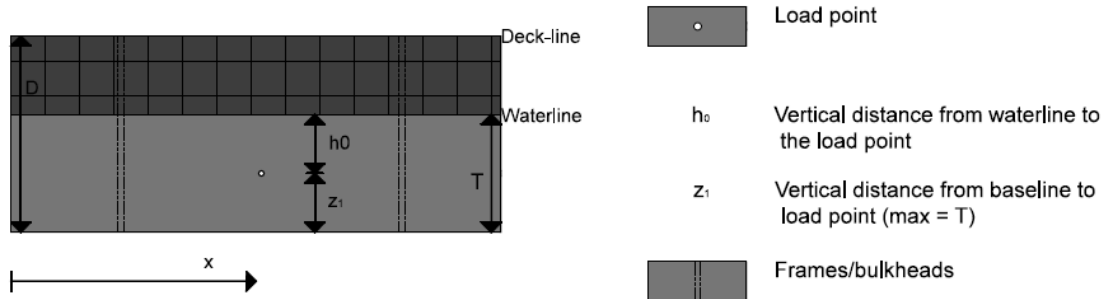

Figure f.2: An overview of the side and terms which is used. Created in AutoCAD

**F.4.1: The sea Pressure Below Summer Load Waterline (p1)**

$$p_1 = 10h_0 + p_{dp} \quad [\text{kN/m}^2] \quad \text{Eq. \{3.17\}}$$

where 
$$p_{dp} = p_L + 135 \cdot \left( \frac{y_1}{B + 75} \right) - 1.2 \cdot (T_{\text{mean}} - z_1)$$

$$p_L := k_s \cdot C_W + k_f \quad p_L = 22.53 \frac{\text{kN}}{\text{m}^2}$$

Figure f.3 illustrates the basic meaning of terms used for the side shells below waterline.

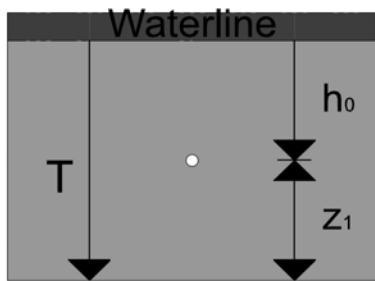

Figure f.3: An overview of the terms used for the side shells below waterline. Created in AutoCAD



Load point: 0.0T

$$z_{1\_0.0T} := 7.5 \text{ m} \quad h_{0\_0.0T} := 0.0 \text{ m}$$

$$P_{dp\_0.0T} := P_L + 135 \cdot \left( \frac{y_1}{B + 75} \right) - 1.2 \cdot (T_{\text{mean}} - z_{1\_0.0T}) \quad P_{dp\_0.0T} = 38.72 \frac{\text{kN}}{\text{m}^2}$$

$$P_{1\_0.0T} := 10 \cdot h_{0\_0.0T} + P_{dp\_0.0T} \quad P_{1\_0.0T} = 38.72 \frac{\text{kN}}{\text{m}^2}$$

Load point: 0.2T

$$z_{1\_0.2T} := 6.0 \text{ m} \quad h_{0\_0.2T} := 1.5 \text{ m}$$

$$P_{dp\_0.2T} := P_L + 135 \cdot \left( \frac{y_1}{B + 75} \right) - 1.2 \cdot (T_{\text{mean}} - z_{1\_0.2T}) \quad P_{dp\_0.2T} = 36.92 \frac{\text{kN}}{\text{m}^2}$$

$$P_{1\_0.2T} := 10 \cdot h_{0\_0.2T} + P_{dp\_0.2T} \quad P_{1\_0.2T} = 51.92 \frac{\text{kN}}{\text{m}^2}$$

Load point: 0.4T

$$z_{1\_0.4T} := 4.5 \text{ m} \quad h_{0\_0.4T} := 3.0 \text{ m}$$

$$P_{dp\_0.4T} := P_L + 135 \cdot \left( \frac{y_1}{B + 75} \right) - 1.2 \cdot (T_{\text{mean}} - z_{1\_0.4T}) \quad P_{dp\_0.4T} = 35.12 \frac{\text{kN}}{\text{m}^2}$$

$$P_{1\_0.4T} := 10 \cdot h_{0\_0.4T} + P_{dp\_0.4T} \quad P_{1\_0.4T} = 65.12 \frac{\text{kN}}{\text{m}^2}$$

Load point: 0.6T

$$z_{1\_0.6T} := 3.0 \text{ m} \quad h_{0\_0.6T} := 4.5 \text{ m}$$

$$P_{dp\_0.6T} := P_L + 135 \cdot \left( \frac{y_1}{B + 75} \right) - 1.2 \cdot (T_{\text{mean}} - z_{1\_0.6T}) \quad P_{dp\_0.6T} = 33.32 \frac{\text{kN}}{\text{m}^2}$$

$$P_{1\_0.6T} := 10 \cdot h_{0\_0.6T} + P_{dp\_0.6T} \quad P_{1\_0.6T} = 78.32 \frac{\text{kN}}{\text{m}^2}$$

Load point: 0.8T

$$z_{1\_0.8T} := 1.5 \text{ m} \quad h_{0\_0.8T} := 6.0 \text{ m}$$

$$P_{dp\_0.8T} := P_L + 135 \cdot \left( \frac{y_1}{B + 75} \right) - 1.2 \cdot (T_{\text{mean}} - z_{1\_0.8T})$$

$$P_{dp\_0.8T} = 31.522 \frac{\text{kN}}{\text{m}^2}$$

$$P_{1\_0.8T} := 10 \cdot h_{0\_0.8T} + P_{dp\_0.8T}$$

$$P_{1\_0.8T} = 91.52 \frac{\text{kN}}{\text{m}^2}$$

Load point: 1.0T

$$z_{1\_1.0T} := 0.0 \text{ m} \quad h_{0\_1.0T} := 7.5 \text{ m}$$

$$P_{dp\_1.0T} := P_L + 135 \cdot \left( \frac{y_1}{B + 75} \right) - 1.2 \cdot (T_{\text{mean}} - z_{1\_1.0T})$$

$$P_{dp\_1.0T} = 29.72 \frac{\text{kN}}{\text{m}^2}$$

$$P_{1\_1.0T} := 10 \cdot h_{0\_1.0T} + P_{dp\_1.0T}$$

$$P_{1\_1.0T} = 104.72 \frac{\text{kN}}{\text{m}^2}$$

Summary of sea pressure below waterline ( $p_1$ ):

<i>Load point</i>	<i><math>h_o</math> [m]</i>	<i><math>z_1</math> [m]</i>	<i><math>P_{dp}</math> [kN/m<sup>2</sup>]</i>	<i><math>P_1</math> [kN/m<sup>2</sup>]</i>
0.0T	0	7.5	38.7	<b>38.7</b>
0.2T	1.5	6.0	36.9	<b>51.9</b>
0.4T	3	4.5	35.1	<b>65.1</b>
0.6T	4.5	3.0	33.3	<b>78.3</b>
0.8T	6	1.5	31.5	<b>91.5</b>
1.0T	7.5	0.0	29.7	<b>104.7</b>

### F.4.2: The sea pressure above summer load waterline (p2)

$$p_2 = a \cdot [p_{dp} - (4 + 0.2 \cdot k_s) \cdot h_0] \quad [\text{kN/m}^2] \quad \text{Eq. \{3.16\}}$$

$$p_{2\_minimum} := 6.25 + 0.025 \cdot L_p \quad p_{2\_minimum} = 9.8 \frac{\text{kN}}{\text{m}^2}$$

Figure f.4 illustrates the basic meaning of terms used for the side shells above waterline.

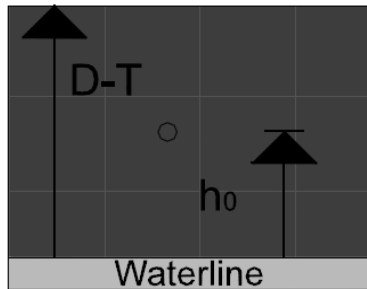

Figure f.4: An overview of the terms used for the side shells above waterline. Created in AutoCAD

$$\text{Load case: } 0.0(D-T) \quad h_{0\_0.0} := 0.0 \text{ m}$$

$$p_{dp\_1} := p_{dp\_0.0T} \quad p_{dp\_1} = 38.72 \frac{\text{kN}}{\text{m}^2}$$

$$p_{2\_0.0} := a \cdot [p_{dp\_1} - (4 + 0.2 \cdot k_s) \cdot h_{0\_0.0}] \quad p_{2\_0.0} = 38.72 \frac{\text{kN}}{\text{m}^2}$$

$$\text{Load case: } 0.2(D-T) \quad h_{0\_0.2} := 1.0 \text{ m}$$

$$p_{2\_0.2} := a \cdot [p_{dp\_1} - (4 + 0.2 \cdot k_s) \cdot h_{0\_0.2}] \quad p_{2\_0.2} = 34.32 \frac{\text{kN}}{\text{m}^2}$$

$$\text{Load case: } 0.4(D-T) \quad h_{0\_0.4} := 2.0 \text{ m}$$

$$p_{2\_0.4} := a \cdot [p_{dp\_1} - (4 + 0.2 \cdot k_s) \cdot h_{0\_0.4}] \quad p_{2\_0.4} = 29.92 \frac{\text{kN}}{\text{m}^2}$$

Load case: 0.6(D-T)  $h_{0,0.6} := 3.0 \text{ m}$

$$p_{2,0.6} := a \cdot [p_{dp,1} - (4 + 0.2 \cdot k_s) \cdot h_{0,0.6}] \quad p_{2,0.6} = 25.52 \frac{\text{kN}}{\text{m}^2}$$

Load case: 0.8(D-T)  $h_{0,0.8} := 4.0 \text{ m}$

$$p_{2,0.8} := a \cdot [p_{dp,1} - (4 + 0.2 \cdot k_s) \cdot h_{0,0.8}] \quad p_{2,0.8} = 21.12 \frac{\text{kN}}{\text{m}^2}$$

Load case: 1.0(D-T)  $h_{0,1.0} := 5.0 \text{ m}$

$$p_{2,1.0} := a \cdot [p_{dp,1} - (4 + 0.2 \cdot k_s) \cdot h_{0,1.0}] \quad p_{2,1.0} = 16.72 \frac{\text{kN}}{\text{m}^2}$$

A summary of sea pressure above summer load waterline ( $p_2$ ).

<i>Load point</i>	<i><math>h_o</math> [m]</i>	<i><math>z</math> [m]</i>	<i><math>p_{dp}</math> [kN/m<sup>2</sup>]</i>	<i><math>p_2</math> [kN/m<sup>2</sup>]</i>
0.0(D-T)	0.0	7.5	38.7	<b>38.7</b>
0.2(D-T)	1.0	7.5	38.7	<b>34.3</b>
0.4(D-T)	2.0	7.5	38.7	<b>29.9</b>
0.6(D-T)	3.0	7.5	38.7	<b>25.5</b>
0.8(D-T)	4.0	7.5	38.7	<b>21.1</b>
1.0(D-T)	5.0	7.5	38.7	<b>16.7</b>

## **APPENDIX G – PLATE CAPACITY CHECK**

# G.1 PLATE SOLELY SUBJECTED TO LOCAL DECK LOAD

G.1.1: How much stresses can the plate withstand if only structure on deck is considered?

**General Input**

Project name:   
 Evaluate and Estimate Stresses on a Vessel's Side Plate and Examine the Pl Identification:   
 Only in-plane transverse stresses considered   
 Safety format:   
 LRFD Material Factor gm = 1.15   
 WSD Allowable Usage Factor, UF = 1.00

**Material**

Plate: S355J2G3 type= 345 MPa   
 Stiffener: S355J2G3 type= 365 MPa   
 Youngs modulus E: 210E+5 MPa

**Continuous stiffener** Snipped stiffener   
 Use recommended values for moment factor and buckling length:  Yes  No Definition:

**Buckling length:** Lk = 1000 mm   
**Moment factor - Field moment:** km2 = 8.0   
 Recommended values: Lk = L km2 = 8  Stiffness Control

**Geometry & Stresses**

Geometry (mm):   
 Stiffener span: L = 1000   
 Length of girder: Lg = 111025   
 Plate thickness: t = 18.0   
 Stiff spacing: s1 = 780 s2 = 780   
 Let top buck length: L1 = 500   
 Stiffener profile: Fb 150X15.0   
 Stresses (MPa):   
 SigmaA = 0.0 SigmaB = 0.0   
 SigmaA = -203.0 SigmaC = -203.0   
 Tau = 0.0 psd = 0.0000   
 Fixation parameter for plate (F300)   
 Clamped edges (kpp=1.0)   
 Simply supported edges (kpp=0.5)

**Figure**

**Buckling/Section Scantling**   
 Buckling - Incl. deformation  More Results   
 Yield  Plate Curve  Stiff Curve   
 Buckling + Yield  Plate/Stiff Curve   
 Consider Vsd/Vd > 0.5  Diagram of Usage Factors   
 Optimize z\*

Control	Interaction Ratio	Reference
<b>PLATE BUCKLING CHECK (DNV-RP-C201):</b>	<b>1.00</b>	< 1.00 (Ch 7.4)
PL1/PL2: Buckling - UF = $\text{Sig}y/\text{k} \cdot \text{sp} \cdot \text{Sig}y/\text{Fd} = 203.0/1.00 \cdot 203.3 =$		
<b>STIFFENER BUCKLING CHECK (DNV-RP-C201): (Z = field; s = stiffener, p = plate)</b>	<b>0.24</b>	< 1.00 (Eq 7.61)
UFZ = $\text{ksd} \cdot \text{Mk} \cdot \text{Rd} \cdot \text{M} \cdot \text{sd} \cdot \text{d}^2 / (\text{Mk} \cdot \text{sd} \cdot \text{d}^2 \cdot 1 \cdot \text{Nsd} \cdot \text{M} \cdot \text{e}) \cdot \text{w} = 0.0/2318.0 \cdot (8 \cdot 7.0 \cdot 0.024 / (35.8 \cdot (1.0/22719.1)) \cdot 0.000 =$		
<b>PLATE YIELD CHECK (Point A-D):</b>	<b>0.68</b>	< 1.00
Yield, max in point A: UF = $\text{Sig}y/\text{fyd} = 203.0/300.0 =$		
<b>PLATE THICKNESS CHECK (DNV-OS-C101, see 5, F 200):</b>	<b>0.32</b>	< 1.00
Primary structure: UF = $\text{km} \cdot \gamma = 5.78/18.00 =$		
<b>STIFFENER YIELD CHECK: (check at point 2, plate) and stiffener(s). Effective width se = 780.0</b>	<b>0.68</b>	< 1.00
Point 2p: UF = $\text{Sig}y/\text{fyd} = 203.0/300.0 =$		

**Conclusions**

Allowable stress from Stipla calculations: -203 MPa in In-plane transverse compression stress

**G.1.2: Stresses equal to 70% of the allowable vertical stress:  
-142.1MPa in-plane compression**

File Stiffener profile Print Help

**General Input**

Project name: \_\_\_\_\_  
 Evaluate and Estimate Stresses on a Vessel's Side Plate and Examine the Pl Identification: \_\_\_\_\_  
 Only in-plane transverse stresses considered

Safety format:  
 LRFD Material Factor: gm = 1.15  
 WSD Allowable Usage Factor: UF = 1.00

Material:  
 Plate: S355J2S3 fyp = 345 MPa  
 Stiffener: S355J2S3 fys = 355 MPa  
 Youngs modulus E: 210E+5 MPa

Continuous stiffener  Sriped stiffener

Use recommended values for moment/actor and buckling length:  Yes  No Definition:

Buckling length: Lk = 1000 mm  
 Moment factor - Field moment: km2 = 8.0  
 Recommended values: Lk = L km2 = 8  Stiffness Control

**Geometry & Stresses**

Stiffener span: L = 1000  
 Length of girder: Lg = 11025  
 Plate thickness: t = 18.0  
 Stiff spacing: s1 = 780 s2 = 780  
 Lst to sb buck length: Lt = 500  
 Stiffener profile: Fb 150x15.0

Stresses (MPa):  
 Sigx = 0.0 Sigy = 0.0  
 Sigxh = -142.0 Sigyh = -142.0  
 Tau = 0.0 psd = 0.000

Fixation parameter for plate (F300):  
 Clamped edges (kpp=1.0)  
 Simply supported edges (kpp=0.5)

**Figure**

Buckling/Section Scantling  Buckling - Incl deformation   
 Yield  Buckling + Yield  
 Consider Vsd/Vyd > 0.5  Diagram of Usage Factors

More Results:  
 Plate Curve | Stiff Curve  
 Plate/Stiff Curve

Optimize z':

Interaction Ratio	Reference
0.70	< 1.00 (Ch 7.4)
0.17	< 1.00 (Eq 7.61)
0.47	< 1.00
0.32	< 1.00
0.47	< 1.00

**Result**

PL1/PL2 Buckling: UF = Sigd/kpp/SigFhd = -142.0/(1.00\*203.3) =  
 STIFFENER BUCKLING CHECK (DNV-RP-C201): (Z = field; s = stiffener; p = plate)  
 UF2 = Nsd/Nk + Hd + (Msd/Nk) \* D2 / (Msd \* Rd1) \* Nsd \* (Nk) + u = 0.0 / (3207.8 + (6.3 \* 0.07 \* 0.016) / (37.1 \* 1.00 \* 35704.0)) + 0.000 =  
 PLATE YIELD CHECK (Points A-D):  
 Yield, max in point: A: UF = Sigd/Ytd = -142.0/300.0 =  
 PLATE THICKNESS CHECK (DNV-OS-C101, sec 5, F 200):  
 Primary structure: UF = tmint = 5.78/18.0 =  
 STIFFENER YIELD CHECK: (check at point Z, plate(s) and stiffener(s)) Effective width se = 780.0  
 Point Zp: UF = Sigd/Ytd = -142.0/300.0 =

## G.2: Plate subjected to in-plane vertical and longitudinal stresses, shear stress and out-of-plane pressure.

### G.2.1: Sagging condition: Design load combination 2 ( from DNV approach).

**File** Stiffener profile Print Help

**General Input**

Project name: Evaluate and Estimate Stresses on a Vessel's Side Plate and Examine the P

Identification: DNV load combination 2, sagging (ref. Appendix A)

Safety format:  LRFD Material Factor gm = 1.15  WSD Allowable Usage Factor, UF = 1.00

Material: S355J2G3 type= 345 MPa  
 S355J2G3 type= 355 MPa  
 Stiffener: S355J2G3 type= 355 MPa  
 Youngs modulus E: 210E+5 MPa

Continuous stiffener  Sriped stiffener

Use recommended values for moment/factor and buckling length:  Yes  No Definition:

Buckling length: Lk = 1000 mm  
 Moment factor - Field moment: km2 = 8.0  
 Recommended values: Lk = L km2 = 8  Stiffness Control

**Geometry & Stresses**

Stiffener span: L = 1000  
 Length of girder: Lg = 11025  
 Plate thickness: t = 18.0  
 Stiff spacing: s1 = 780 s2 = 780  
 Lst (stiff buck length): L1 = 500  
 Stiffener profile: FD 150x15.0

Stresses (MPa):  
 SigxA = -52.8 SigxB = 35.7  
 SigyA = -142.0 SigyC = 142.0  
 Tau = -79.7 psd = 0.020

Fixation parameter for plate (F300):  
 Clamped edges (kpp=1.0)  
 Simply supported edges (kpp=0.5)

**Figure**

**Buckling/Section Scantling**  
 Buckling - Incl. deformation  
 Yield  
 Buckling + Yield  
 Consider Vsd/Vtd > 0.5   
 Optimize z\*

More Results  
 Plate Curve  Stiff Curve  
 Plate/Stiff Curve  
 Diagram of Usage Factors

**Result**

**Control**

**PLATE BUCKLING CHECK (DNV-RP-C201):**  
 PL1/PL2: Buckling - UF = Sigy/(ksp\*SigPd) = -142.0/(0.392\*203.3) = 0.76 < 1.00 (Ch. 7.4)  
 STIFFENER BUCKLING CHECK (DNV-RP-C201): L2 = field: s = stiffener, p = plate  
 UF2=sksd/Nk/Rd=2\*NSd/NRd/(kSdH1Sd2)/(skHd\*(1+NSd/Ns)u) = 621.3/2323.6\*2\*621.3/3598.7+8.3\*621.3\*0.016/(37.4\*(1+621.3/35984.9))u=0.212 = 0.55 < 1.00 (Eq. 7.55)  
 Shear check: Vsd/Vtd = 78.40/10 = 0.02 < 0.50 (Ch. 7.8)

**PLATE YIELD CHECK (Points A-D) AND LATERAL CHECK:**  
 Yield max in point: B: UF = Sigd/Vtd = 188.2/200.0 = 0.63 < 1.00  
 PLATE THICKNESS CHECK (DNV-OS-C101, sec 5, F 300):  
 Point: B: Sigd = 188.2 MPa, UF = hmax/t = 374/18.00 = 0.21 < 1.00

**STIFFENER YIELD CHECK (check at point Z, plate(p) and stiffener(s)) Effective width se = 780.0**  
 Point Zp: UF = Sigd/Vtd = 186.6/300.0 = 0.62 < 1.00

**STIFFENER SECTION MODULUS CHECK (DNV-OS-C101, sec 5, F 400) (check at point Z, plate(p) and stiffener(s))**  
 Effective width se = 780.0 mm calculated according to DNV OS C101, sec 5, G400 (Np)5  
 Point Z\*: Smod = 44.3 MPa, UF = Z\*Avs = 1.50MVs = 1.50MVs = 1.12 < 1.00

Interaction Ratio	Reference
0.76	< 1.00 (Ch. 7.4)
0.55	< 1.00 (Eq. 7.55)
0.02	< 0.50 (Ch. 7.8)
0.63	< 1.00
0.21	< 1.00
0.62	< 1.00
1.12	< 1.00



**G.2.2: Hogging condition: Deisgn load combination 2 ( from DNV approcach).**

File Stiffener profile Print Help

**General Input**  
 Project name:  
 Evaluate and Estimate Stresses on a Vessel's Side Plate and Examine the Pl  
 Identification:  
 all stresses included: Load combination 2, hogging  
 Safety format:  
 LRFD Material Factor: gm = 1.15  
 WSD Allowable Usage Factor: UF = 1.00

Material:  
 Plate: S355J2G3 fyp = 345 MPa  
 Stiffener: S355J2G3 fys = 355 MPa  
 Young's modulus E: 2.10E+5 MPa

Continuous stiffener Sniped stiffener  
 Use recommended values for moment factor and buckling length: Yes No Definition:  
 Buckling length: Lk = 1000 mm  
 Moment factor - Field moment: km2 = 8.0  
 Recommended values: Lk = L km2 = 8 Stiffness Control

**Geometry & Stresses**  
 Geometry (mm)  
 Stiffener span: L = 1000  
 Length of girder: Lg = 11025  
 Plate thickness: t = 18.0  
 Stiff spacing: s1 = 780 s2 = 780  
 Lattors bucklength: L1 = 500  
 Stiffener profile: Fb 150x15.0  
 Stresses (MPa)  
 SigxA = 53.9 SigxB = 36.4  
 SigyA = -142.0 SigyC = 142.0  
 Tau = 86.8 pd = -0.020  
 Friction parameter for plate (kpp=1.0)  
 Clamped edges (kcp=0)  
 Simply supported edges (ksp=0.5)

**Figure**

Buckling/Section Scantling  
 Buckling - Incl. deformation  
 Yield  
 Buckling + Yield  
 Consider Vsd/Vyd > 0.5  
 Optimize z?  
 More Results  
 Plate Curve  
 Stiff Curve  
 Plate/Stiff Curve  
 Diagram of Usage Factors

**Control**  
**PLATE BUCKLING CHECK (DNV-RP-C201):**  
 PL1, PL2: Buckling: UF = Sigy/(ksp\*SigRd) = 142.0/(0.90\*203.3) =  
**STIFFENER BUCKLING CHECK (DNV-RP-C201):** (Z = field; s = stiffener; p = plate)  
 UF2p = Nsd/(kcp\*pd + 2\*Nsd/DNVDH\*(M5d\*sd/z)/(MppRd1) + Nsd/(Np\*H)) = 633.9/(3212.7\*2 + 633.9/(3388.7\*4.3 - 633.9\*(90.017)/(305.8\*1) - 633.9/(35558.8)\*1) + 0.251 =  
 Shear check: Vsd/Vyd = 78/401.0 =  
**PLATE YIELD CHECK (Points A-D) AND LATERAL CHECK:**  
 Yield: max in point: A: UF = Sigd/fyd = 230.9/300.0 =  
**PLATE THICKNESS CHECK (DNV-OS-C101, sec 5, F 300):**  
 Point A: Sigd = 230.9 MPa UF = (mm)^1 = 4.78/18.00 =  
**STIFFENER YIELD CHECK: (check at point 2, plate(p) and stiffener(s))**  
 Point 2p: UF = Sigd/fyd = 225.7/300.0 =  
**STIFFENER SECTION MODULUS CHECK (DNV-OS-C101, sec 5, F 400) (check at point 2, plate(p) and stiffener(s))**  
 Effective width: se = 780.0 mm, calculated according to DNV OS C101, sec 5, G400, Np/5  
 Point 2s: Sred = 45.2 MPa, IIF = Zs\*Av/s = 1.50MPa\*4.71/200E-5 =

Interaction Ratio	Reference
0.78	< 1.00 (Ch 7.4)
0.48	< 1.00 (Eq 7.62)
0.02	< 0.50 (Ch 7.8)
0.77	< 1.00
0.26	< 1.00
0.75	< 1.00
0.12	< 1.00

**G.2.3: Loading condition from Seven Seas NAPA software: still-water light ship condition with a 400 ton deck load at aft. and a 200 ton structure on deck located at webframe 72.**

Stiffener profile Print Help

General Input

Project name: Evaluate and Estimate Stresses on a Vessel's Side Plate and Examine the P

Identification: NAPA specified load condition

Safety format:  LRFD Material Factor gm = 1.15  W/SO Allowable Usage Factor, UF = 1.00

Material: S355J2G3 type= 345 MPa  
 Plate: S355J2G3 type= 355 MPa  
 Stiffener: S355J2G3 type= 355 MPa  
 Young's modulus E: 2.10E+5 MPa

Continuous stiffener Shaped stiffener

Use recommended values for moment factor and buckling length:  Yes  No Definition:

Buckling length: Lk = 1000 mm  
 Moment factor - Field moment: km2 = 8.0  
 Recommended values: Lk = L km2 = 8  Stiffness Control

Geometry & Stresses

Stiffener span: L = 1000  
 Length of girder: Lg = 11025  
 Plate thickness: t = 18.0  
 Stiff spacing: s1 = 780 s2 = 780  
 Lattens buck length: Lt = 500  
 Stiffener profile: Fb 150x15.0

Stresses (MPa):  
 SigxA = -8.9 SigxB = -6.0  
 SigyA = -142.0 SigyC = -142.0  
 Tau = 32.9 psd = -0.020

Fraction parameter for plate (F300)  Clamped edges (kcp=1.0)  Simply supported edges (kcp=0.5)

Buckling/Section Scantling:  Buckling - Incl. deformation  More Results  
 Yield  Plate Curve  Stiff Curve  
 Buckling + Yield  Consider Vsd/Vtd > 0.5  Plate/Stiff Curve  
 Optimize z\*  Diagram of Usage Factors

Figure:

Result

Control

PLATE BUCKLING CHECK (DNV-RP-C201):  
 P1.1/P1.2: Buckling - UF = Sigy/ke\*SigRd = -142.0/0.99\*203.31 = 0.71  
 STIFFENER BUCKLING CHECK (DNV-RP-C201): (Z = head, s = stiffener, p = plate)  
 UF2s=ss/NKSRd2\*NSUNd+h1sd+h2sd2/(MSRd1+MSdNe)pu = 104.6/3227.8\*2\*104.6/3482.0+8\*2+104.6\*0.016/(37.3\*11-104.6/35753.8)+0.036 = 0.28  
 Shear check: Vsd/Vtd = 7.8/40.1 = 0.20  
 PLATE YIELD CHECK (Points A-D) AND LATERAL CHECK:  
 Yield, max in point: B: UF = Sigd/tyd = 150.3/300.0 = 0.50  
 PLATE THICKNESS CHECK (DNV-Q5-C101, sec 5, F 300):  
 Point: B: Sigd = 150.3 MPa UF = tmin/t = 3.24/18.00 = 0.18  
 STIFFENER YIELD CHECK: (check at point Z, plate(p) and stiffener(s))  
 STIFFENER SECTION MODULUS CHECK (DNV-Q5-C101, sec 5, F 400): (check at point Z, plate(p) and stiffener(s))  
 Effective width se = 780.0 mm calculated according to DNV-Q5-C101, sec 5, G400, Hp/5  
 Point 2s: Stnd = 7.5 MPa, IIF = Zs\*Avs = 1.50MF\*4.71 2MF\*5 = 0.50  
 Point 2p: Stnd = 7.5 MPa, IIF = Zs\*Avs = 1.50MF\*4.71 2MF\*5 = 0.12

Interaction Ratio	Reference
0.71	< 1.00 (Ch 7.4)
0.28	< 1.00 (Eq 7.5)
0.20	< 0.50 (Ch 7.8)
0.50	< 1.00
0.18	< 1.00
0.50	< 1.00
0.12	< 1.00

### G.3: The effect of changing shear stress and in-plane longitudinal stress

At what shear stress would the plate buckling limit be reached if assumed 70% allowable vertical stress from structure on deck?

**General Input**

Project name: Evaluate and Estimate Stresses on a Vessel's Side Plate and Examine the Pl Identification.

Load combination 2, sagging condition

Safety format: LFRD

Material Factor, gm = 1.15

WSD Allowable Usage Factor, UF = 1.00

Material: S355J2G3

Plate: S355J2G3

Stiffener: S355J2G3

Young's modulus E: 210E+5 MPa

Continuous stiffener: Striped stiffener

Use recommended values for moment factor and buckling length: Yes

Buckling length: Lk = 1000 mm

Moment factor - Field moment: km2 = 8.0

Recommended values: Lk = L km2 = 8 Stiffness Control

**Geometry & Stresses**

Stiffener spar: L = 1000

Length of girder: Lg = 11025

Plate thickness: t = 18.0

Stiff spacing: s1 = 780, s2 = 780

Stiffener profile: Fb 150x15.0

Stresses (MPa): Sigx = 8.9, Sigy = 6.0, Sigz = -142.0, SigxC = -142.0, Tau = 142.0, psd = -0.020

Fixation parameter for plate (F300): Clamped edges (kpp=1.0), Simply supported edges (kpp=0.5)

**Figure**

Buckling/Section Scantling

Buckling - Incl deformation

Yield

Buckling + Yield

Consider Vsd/Vd > 0.5

Optimize z\*

Diagram of Usage Factors

**Result**

Control	Interaction Ratio	Reference
PLATE BUCKLING CHECK (DNV-RP-C201):	1.00	< 1.00 (Ch 7.4)
PL1/PL2 Buckling - UF = Sigy/(ksp * SigRef) = -142.0/(0.70*203.3) =	0.91	< 1.00 (Eq 7.55)
STIFFENER BUCKLING CHECK (DNV-RP-C201) - (2 = field; s = stiffener, p = plate)	0.02	< 0.50 (Ch 7.8)
UF2 = s * Nsd / (k * Rd * 2 * Ns * d * N * Sd * H * Sd * z) / (M * Sd * V * H * U) = 104.6 / (2 * 227.8 * 2 * 104.6 * 0.016) / (37.3 * 11 - 104.6 / (35753.8) * 0.672) =	0.94	< 1.00
Shear check: Vsd/Vd = 7.8/401.0 =	0.53	< 1.00
PLATE YIELD CHECK (Points A-D) AND LATERAL CHECK:	0.94	< 1.00
Yield, max in point B: UF = SigRef/Vd = 282.6/300.0 =	0.94	< 1.00
PLATE THICKNESS CHECK (DNV-QS-C101, sec 5, F 300):	0.94	< 1.00
Point B: Sigpl = 282.6 MPa UF = tmm/vl = 9.48/18.00 =	0.94	< 1.00
STIFFENER YIELD CHECK (check at point 2, plate(p) and stiffener(s)):	0.94	< 1.00
Point 2p: UF = Sigpl/Vd = 282.0/300.0 =	0.94	< 1.00
STIFFENER SECTION MODULUS CHECK (DNV-QS-C101, sec 5, F 400) (check at point 2, plate(p) and stiffener(s)):	0.12	< 1.00
Effective width sw = 780.0 mm calculated according to DNV-QS-C101, sec 5, G 400, Np 5		
Point 2s: Stnd = 7.5 MPa, UF = Z * Vsd / (s * Vd) = 1.50 * 7.5 / (18.0 * 7.5) =		

Conclusion: -142MPa shear stress. The result indicated that the shear stress does influence all failure modes.

Does the longitudinal in-plane stress (global bending stress) influence the plate buckling failure?

File Stiffener profile Print Help

**General Input**  
 Project name: Evaluate and Estimate Stresses on a Vessels side Plate and Examine the Pl  
 Identification: Load combination 2: sagging condition  
 Safety format: LRFD Material Factor gm = 1.15  
 WSD Allowable Usage Factor, UF = 1.00

**Material**  
 Plate: S355J2G3 Iyp = 345 MPa  
 Stiffener: S355J2G3 Iys = 355 MPa  
 Youngs modulus E: 21.0E+5 MPa

**Continuous stiffener** Sniped stiffener  
 Use recommended values for moment/flactor and buckling length: Yes No Definition:

**Buckling length:** Lk = 1000 mm  
**Moment factor - Field moment:** km2 = 8.0  
 Recommended values: Lk = L km2 = 8 Stiffness Control

**Geometry & Stresses**  
 Stiffener span: L = 1000  
 Length of girder: Lg = 11025  
 Plate thickness: t = 18.0  
 Stiff spacing: s1 = 780 s2 = 780  
 Lat loss buckl length: Lt = 500  
 Stiffener profile: Fb 150x15.0

**Stresses (MPa)**  
 SigmaA = -40.0 SigmaB = -40.0  
 SigmaA = -142.0 SigmaC = -142.0  
 Tau = -142.0 psd = -0.020

**Fixation parameter for plate (F300)**  
 Clamped edges (kcp=1.0)  
 Simply supported edges (kcp=0.5)

**Figure**

**Buckling/Section Scantling**  
 Buckling - Incl. deformation   
 Yield   
 Buckling + Yield   
 Consider Vsd/Vsd > 0.5   
 Optimize z?   
 Diagram of Usage Factors

**More Results**  
 Plate Curve  Stiff Curve   
 Plate/Stiff Curve

**Result**  
**PLATE BUCKLING CHECK (DNV-RP-C201):**  
 PL1/PL2 Buckling - UF =  $\text{Sigy}/(\text{ksp} \cdot \text{SigRd}) = 1.42/0.070(203.3) = 1.00$   
**STIFFENER BUCKLING CHECK (DNV-RP-C201):** (2 = field; s = stiffener, p = plate)  
 UF2s =  $\text{Nsd}/(\text{NksRd} + 2 \cdot \text{Nsd}/\text{Rd} + \text{Msd}/\text{Msd} + \text{Nsd}/\text{Rd} + \text{Msd}/\text{Msd} + \text{Nsd}/\text{Rd} + \text{Msd}/\text{Msd}) + \text{Nsd}/\text{Rd} = 561.6/3303.8 + 2 \cdot 561.6/3574.5 + 18.3 + 561.6/0.016/37.4 + 1.561.6/35938.0 + 0.672 = 0.02$   
 Shear check: Vsd/Vsd = 7.8/401.0 = 0.02  
**PLATE YIELD CHECK (Points A-D) AND LATERAL CHECK:**  
 Yield, max in point: A: UF =  $\text{Sigd}/\text{Iyd} = 276.7/300.0 = 0.92$   
**PLATE THICKNESS CHECK (DNV-OS-C101, sec 5, F 300):**  
 Point A: Sigd = 276.7 MPa UF =  $\text{Imin}/t = 8.21/18.00 = 0.46$   
**STIFFENER YIELD CHECK: (check at point 2, plate) and stiffener(s))**  
 Point 2p: UF =  $\text{Sigd}/\text{Iyd} = 276.6/300.0 = 0.92$   
**STIFFENER SECTION MODULUS CHECK (DNV-OS-C101, sec 5, F 400): (check at point 2, plate) and stiffener(s))**  
 Effective width se = 780.0 mm calculated according to DNV OS C101, sec 5, G400, Np > 5  
 Point 2e: Sigwd = 41.0 MPa UF =  $Z \cdot \text{Ave} = 1.500E+4/1.240E+5 = 0.12$

Interaction Ratio	Reference
1.00	< 1.00 (Ch 7.4)
1.00	< 1.00 (Eq 7.55)
0.02	< 0.50 (Ch 7.8)
0.92	< 1.00
0.46	< 1.00
0.92	< 1.00
0.12	< 1.00

Conclusion: It does not influence the plate buckling but it does influence the other failure modes.

## **APPENDIX H - HOLLAND PROFILE TABLE**

Taken from:

[http://www.tatasteeleurope.com/file\\_source/StaticFiles/Business%20Units/Special%20Strip/Bulbflat.pdf](http://www.tatasteeleurope.com/file_source/StaticFiles/Business%20Units/Special%20Strip/Bulbflat.pdf)

## Dimensions and properties

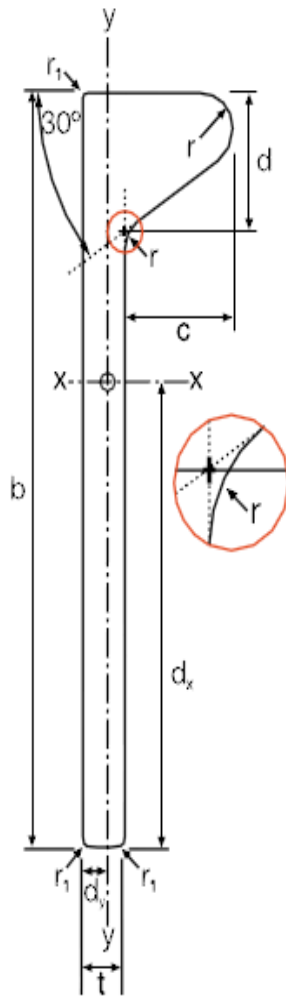

Width b [mm]	Thickness t [mm]	Mass per Unit Length G [kg/m]	Bulb Height c [mm]	Bulb Width d [mm]	Bulb Radius r [mm]	Area of cross-section F [cm <sup>2</sup> ]	Surface Area U [m <sup>2</sup> /m]
120	6	7.31	17	17.7	5	9.31	0.276
	7	8.25	17	17.7	5	10.5	0.278
	8	9.19	17	17.7	5	11.7	0.280
140	6.5	9.21	19	19.7	5.5	11.7	0.319
	7	9.74	19	19.7	5.5	12.4	0.320
	8	10.8	19	19.7	5.5	13.8	0.322
	10	13.0	19	19.7	5.5	16.6	0.326
160	7	11.4	22	22.2	6	14.6	0.365
	8	12.7	22	22.2	6	16.2	0.367
	9	14.0	22	22.2	6	17.8	0.369
	11.5	17.3	22	22.2	6	21.8	0.374
180	8	14.8	25	25.5	7	18.9	0.411
	9	16.2	25	25.5	7	20.7	0.413
	10	17.6	25	25.5	7	22.5	0.415
	11.5	19.7	25	25.5	7	25.2	0.418
200	8.5	17.8	28	28.8	8	22.6	0.456
	9	18.5	28	28.8	8	23.6	0.457
	10	20.1	28	28.8	8	25.6	0.459
	11	21.7	28	28.8	8	27.6	0.461
	12	23.2	28	28.8	8	29.6	0.463
220	9	21.0	31	32.1	9	26.8	0.501
	10	22.8	31	32.1	9	29.0	0.503
	11	24.5	31	32.1	9	31.2	0.505
	12	26.2	31	32.1	9	33.4	0.507
240	9.5	24.4	34	35.4	10	31.2	0.546
	10	25.4	34	35.4	10	32.4	0.547
	11	27.4	34	35.4	10	34.9	0.549
	12	29.3	34	35.4	10	37.3	0.551
260	10	28.3	37	38.7	11	36.1	0.593
	11	30.3	37	38.7	11	38.7	0.593
	12	32.4	37	38.7	11	41.3	0.595
280	10.5	32.4	40	42.0	12	41.2	0.636
	11	33.5	40	42.0	12	42.6	0.637
	12	35.7	40	42.0	12	45.5	0.639
	13	37.9	40	42.0	12	48.4	0.641
300	11	36.7	43	45.3	13	46.7	0.681
	12	39.0	43	45.3	13	49.7	0.683
	13	41.5	43	45.3	13	52.8	0.685
320	11.5	41.2	46	48.6	14	52.6	0.727
	12	42.5	46	48.6	14	54.2	0.728
	13	45.0	46	48.6	14	57.4	0.730
	14	47.5	46	48.6	14	60.6	0.732
340	12	46.1	49	52.0	15	58.8	0.772
	13	48.8	49	52.0	15	62.2	0.774
	14	51.5	49	52.0	15	65.5	0.776
	15	54.2	49	52.0	15	69.0	0.778
370	12.5	53.1	53.5	56.9	16.5	67.8	0.839
	13	54.6	53.5	56.9	16.5	69.6	0.840
	14	57.5	53.5	56.9	16.5	73.3	0.842
	15	60.5	53.5	56.9	16.5	77.0	0.844
	16	63.5	53.5	56.9	16.5	80.7	0.846
400	13	60.8	58	61.9	18	77.4	0.907
	14	63.9	58	61.9	18	81.4	0.908
	15	67.0	58	61.9	18	85.4	0.910
	16	70.2	58	61.9	18	89.4	0.912
430	14	70.6	62.5	66.8	19.5	89.7	0.975
	15	73.9	62.5	66.8	19.5	94.1	0.976
	17	80.6	62.5	66.8	19.5	103.0	0.980
	20	90.8	62.5	66.8	19.5	115.0	0.986

Distance of Centre of Cravity		Second Moment of Area		Elastic Modulus		Radius of Gyration		Warping Constant	Torsional Constant
$d_x$ [mm]	$d_y$ [mm]	Axis x - x [cm <sup>2</sup> ]	Axis y - y [cm <sup>2</sup> ]	Axis x - x [cm <sup>2</sup> ]	Axis y - y [cm <sup>2</sup> ]	Axis x - x [cm]	Axis y - y [cm]	$I^*$ [cm <sup>4</sup> (x10 <sup>8</sup> )]	J [cm <sup>4</sup> ]
72.0	5.3	133	2.34	18.4	4.42	3.78	0.50	0.242	1.595
70.7	5.6	148	2.70	21.0	4.82	3.75	0.51	0.251	2.100
69.6	6.0	164	3.10	23.6	5.17	3.74	0.51	0.263	2.773
83.7	5.8	228	3.57	27.3	6.16	4.41	0.55	0.504	2.383
83.1	5.9	241	3.80	29.0	6.44	4.41	0.55	0.508	2.708
81.8	6.3	266	4.32	32.5	6.86	4.39	0.56	0.528	3.501
79.2	7.0	316	5.56	39.9	7.94	4.36	0.58	0.575	5.752
96.6	6.4	373	5.86	38.6	9.16	5.05	0.63	1.12	3.681
94.9	6.8	411	6.55	43.3	9.63	5.04	0.64	1.16	4.600
93.6	7.1	448	7.32	47.9	10.3	5.02	0.64	1.20	5.763
91.1	8.1	544	9.62	59.8	11.9	5.00	0.66	1.31	9.936
109	7.4	609	9.90	55.9	13.4	5.68	0.72	2.45	6.352
107	7.7	665	10.93	62.1	14.2	5.67	0.73	2.51	7.686
106	8.1	717	12.05	67.8	14.9	5.65	0.73	2.58	9.328
104	8.6	799	13.93	76.8	16.2	5.63	0.74	2.71	12.44
122	8.2	902	15.07	74.0	18.4	6.32	0.82	4.67	9.129
121	8.4	941	15.76	77.7	18.8	6.31	0.82	4.72	9.924
119	8.7	1020	17.21	85.0	19.8	6.31	0.82	4.83	11.70
118	9.0	1090	18.77	92.3	20.9	6.28	0.82	4.93	14.00
117	9.4	1160	20.46	99.6	21.8	6.26	0.83	5.09	16.65
136	9.1	1296	22.03	95.3	24.2	6.95	0.91	8.64	13.24
134	9.3	1400	23.89	105	25.7	6.95	0.91	8.80	15.31
132	9.6	1500	25.86	113	26.9	6.93	0.91	8.98	17.81
130	10.0	1590	27.98	122	28.0	6.90	0.92	9.18	20.76
148	9.9	1800	31.15	123	31.5	7.60	1.00	14.8	18.16
147	10.0	1860	32.34	126	32.3	7.58	1.00	14.9	19.37
146	10.3	2000	34.81	137	33.8	7.57	1.00	15.3	22.46
144	10.6	2130	37.43	148	35.3	7.56	1.00	15.6	25.73
162	10.7	2477	42.84	153	40.0	8.28	1.09	24.7	25.03
160	11.0	2610	45.90	162	41.7	8.21	1.09	25.0	28.09
158	11.3	2770	49.11	175	43.5	8.19	1.09	25.4	31.68
175	11.6	3223	57.55	184	49.6	8.84	1.18	39.0	33.05
174	11.7	3330	59.44	191	50.8	8.84	1.18	39.2	34.80
172	11.9	3550	63.34	206	53.2	8.83	1.18	40.1	39.19
170	12.2	3760	67.42	221	55.3	8.81	1.18	41.0	44.25
189	12.4	4190	75.74	222	61.1	9.47	1.27	59.9	43.25
187	12.6	4460	80.44	239	63.8	9.47	1.27	60.5	47.55
185	12.9	4720	85.33	256	66.1	9.45	1.27	61.8	53.06
202	13.3	5370	97.92	266	73.6	10.10	1.36	89.9	56.02
201	13.4	5530	100.8	274	75.2	10.10	1.36	90.3	58.45
199	13.6	5850	106.6	294	78.6	10.10	1.36	91.2	63.86
197	13.9	6170	112.6	313	81.0	10.09	1.36	92.3	70.06
215	14.1	6760	124.6	313	88.4	10.72	1.46	131	71.17
213	14.3	7160	131.5	335	92.0	10.73	1.45	132	77.02
211	14.6	7540	138.6	357	94.9	10.73	1.45	133	83.00
209	14.8	7920	145.9	379	98.6	10.71	1.45	135	91.30
236	15.4	9213	172.3	390	112	11.66	1.59	221	97.66
235	15.4	9470	176.7	402	115	11.66	1.59	221	100.7
232	15.6	9980	185.7	428	119	11.67	1.59	223	108.1
230	15.9	10490	194.8	455	123	11.67	1.59	225	116.6
228	16.1	10980	204.3	481	127	11.66	1.59	227	126.0
258	16.6	12280	232.4	476	140	12.60	1.73	357	131.0
255	16.8	12930	243.6	507	145	12.60	1.73	359	139.3
252	17.0	13580	255.0	537	150	12.61	1.73	362	148.7
250	17.2	14220	266.6	568	155	12.61	1.73	364	159.6
277	17.9	16460	313.9	594	175	13.55	1.87	557	176.6
274	18.1	17260	327.9	628	181	13.54	1.87	562	187.9
269	18.5	18860	356.7	700	193	13.53	1.86	576	215.6
263	19.3	21180	402.6	804	209	13.57	1.87	570	252.6

## **APPENDIX J - DRAWINGS OF THE *SEVEN SEAS***



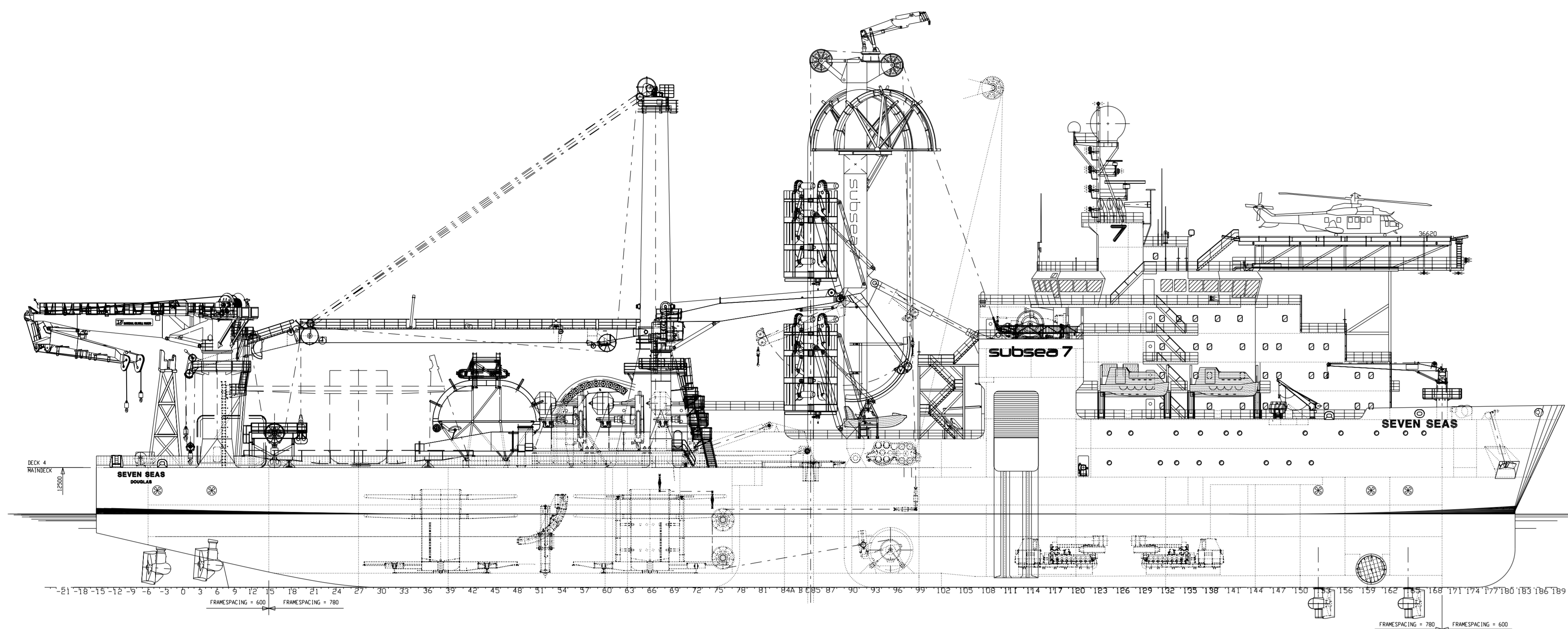

DECK 12	HELIDECK
DECK 11	TOP DECK
DECK 10	BRIDGE DECK
DECK 9	A-DECK
DECK 8	B-DECK
DECK 7	C-DECK
DECK 6	D-DECK
DECK 5	E-DECK
DECK 4	MAIN DECK
DECK 3	UPPER TWEENDECK
DECK 2	LOWER TWEENDECK
DECK 1	TANKTOP

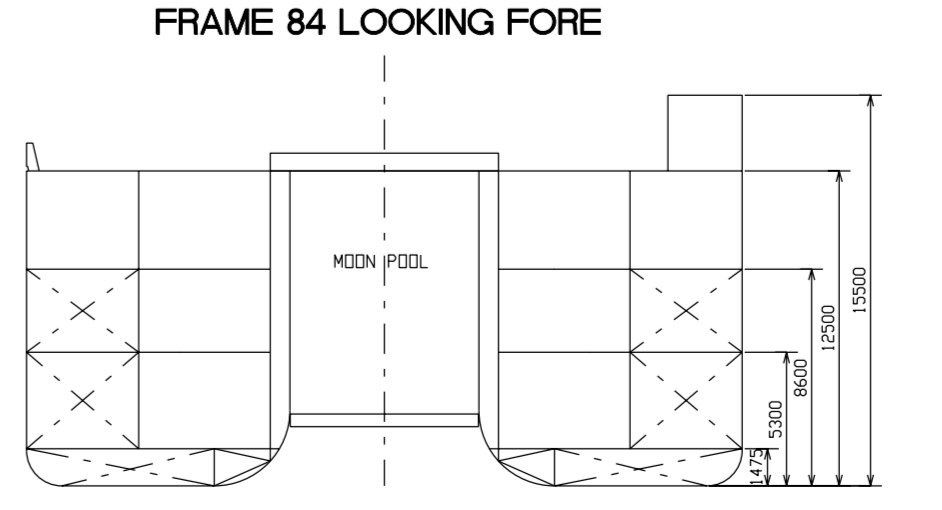
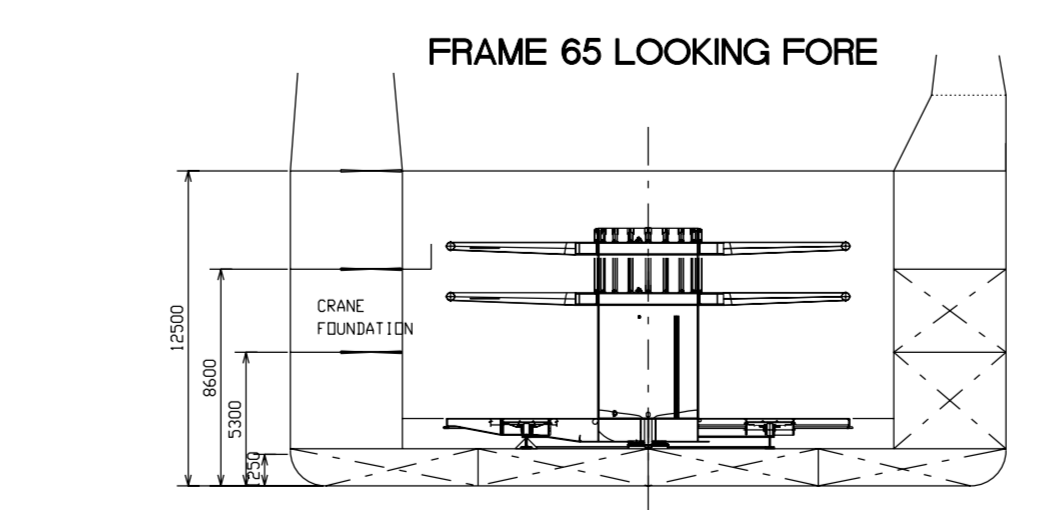
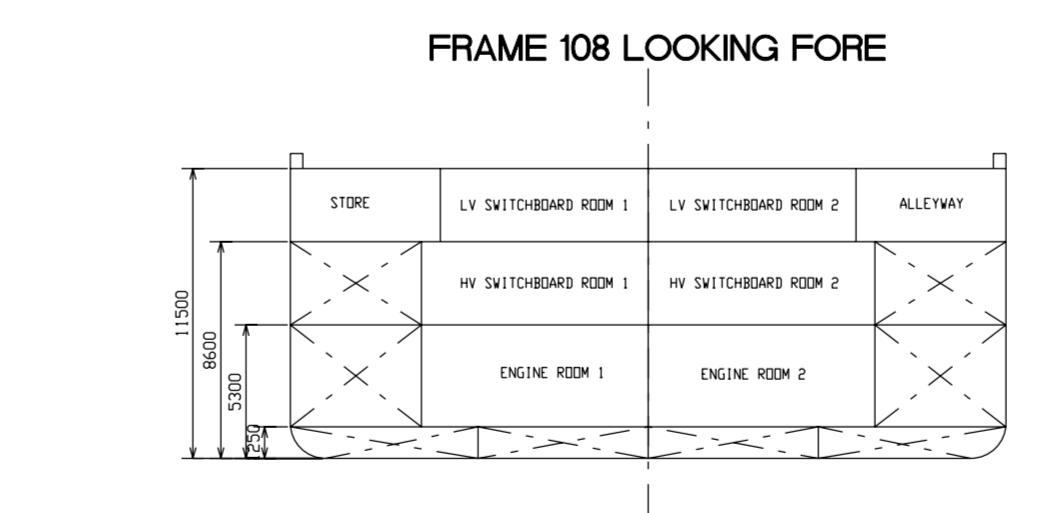
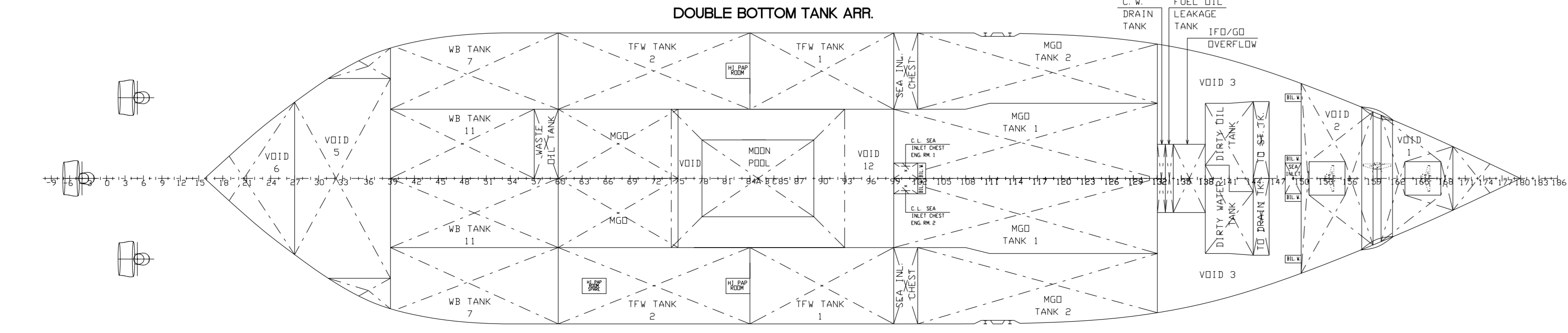
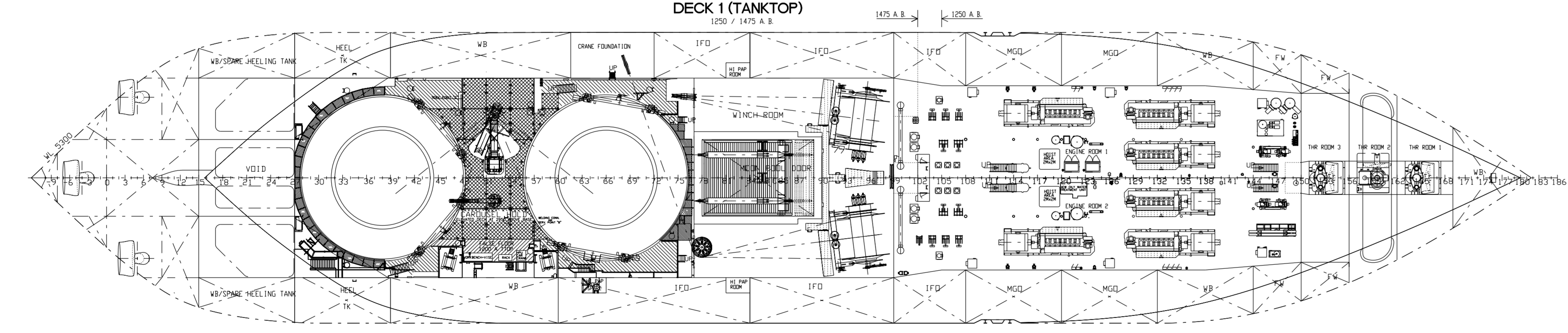
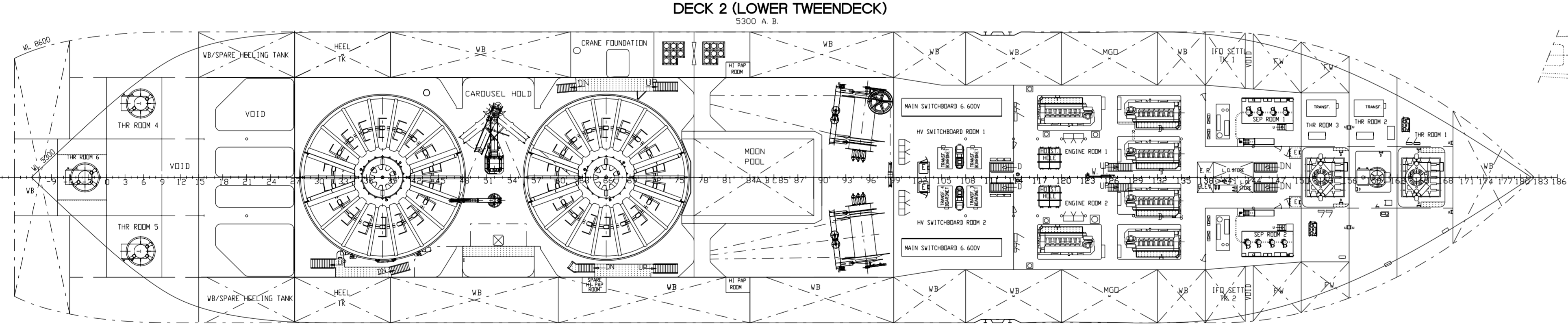
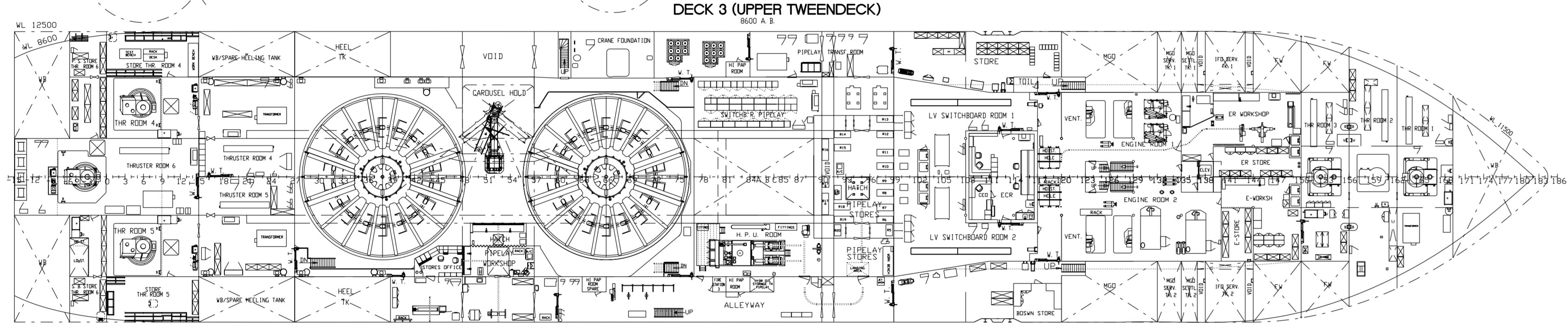
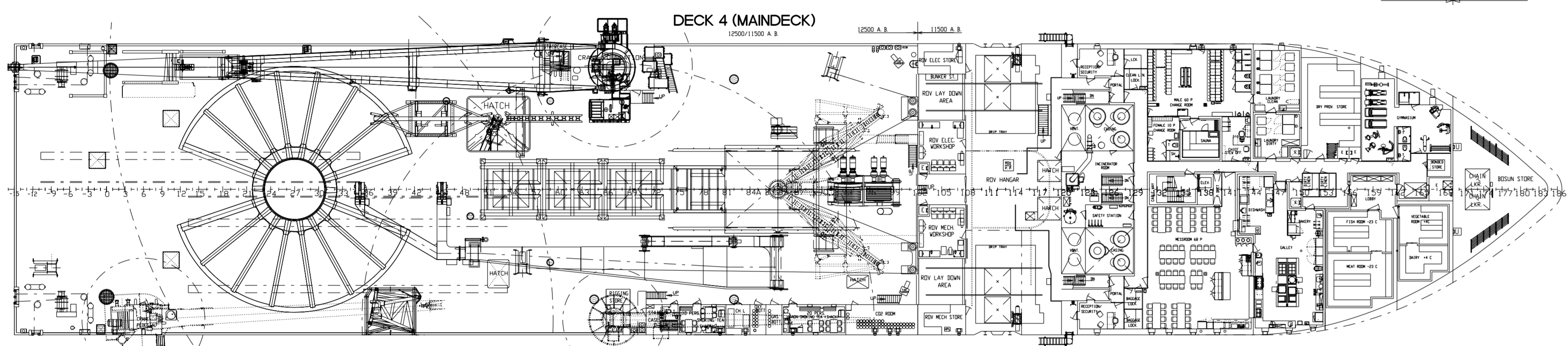
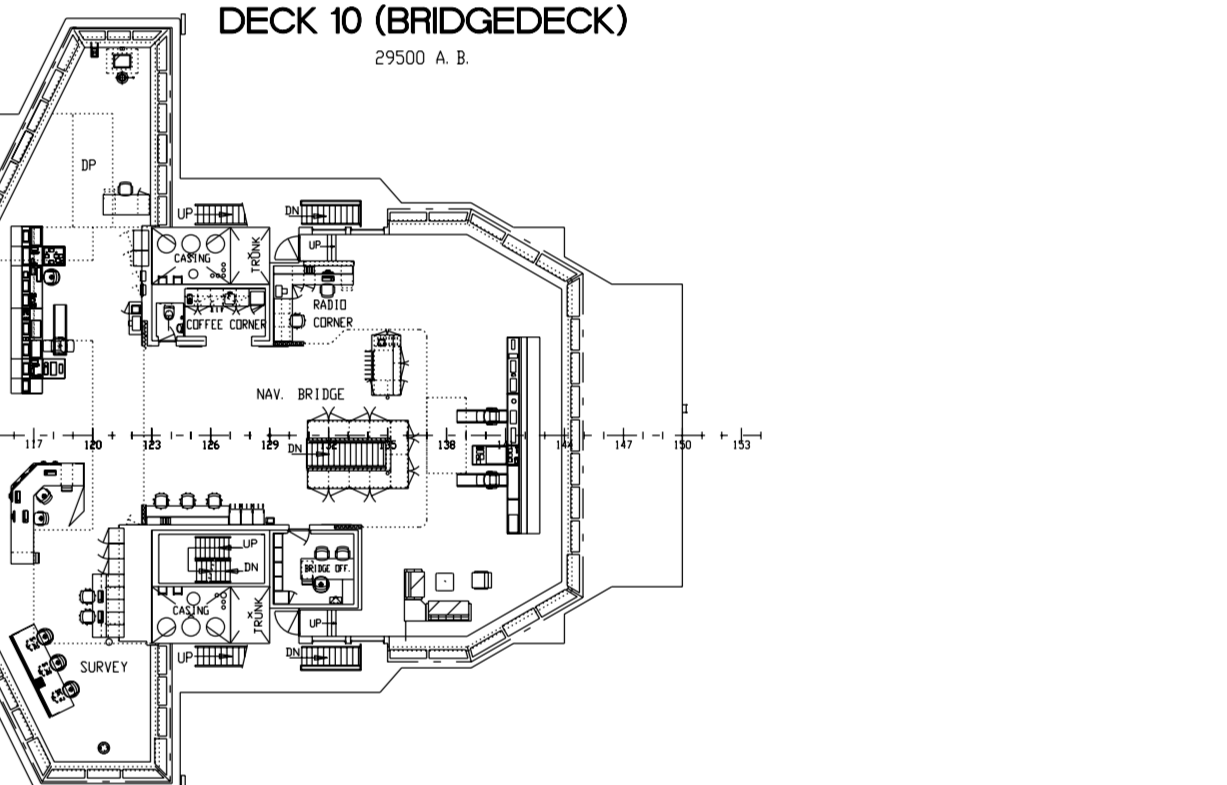
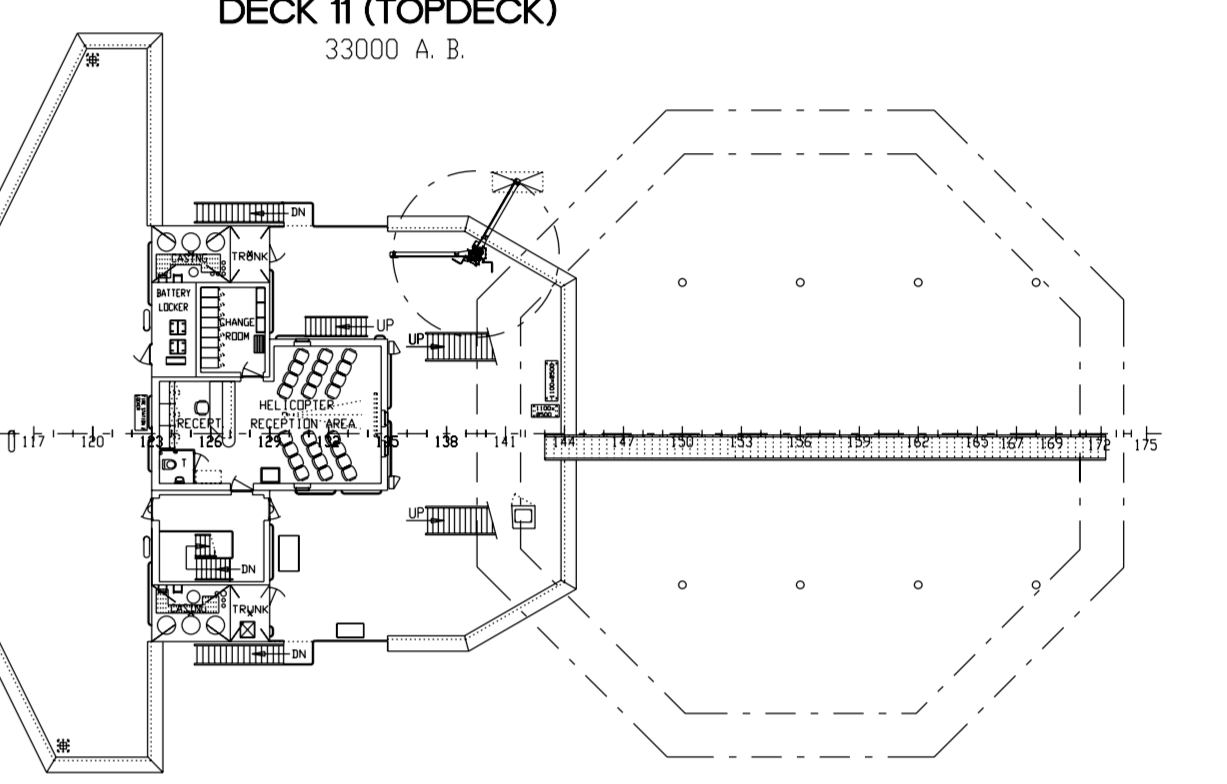
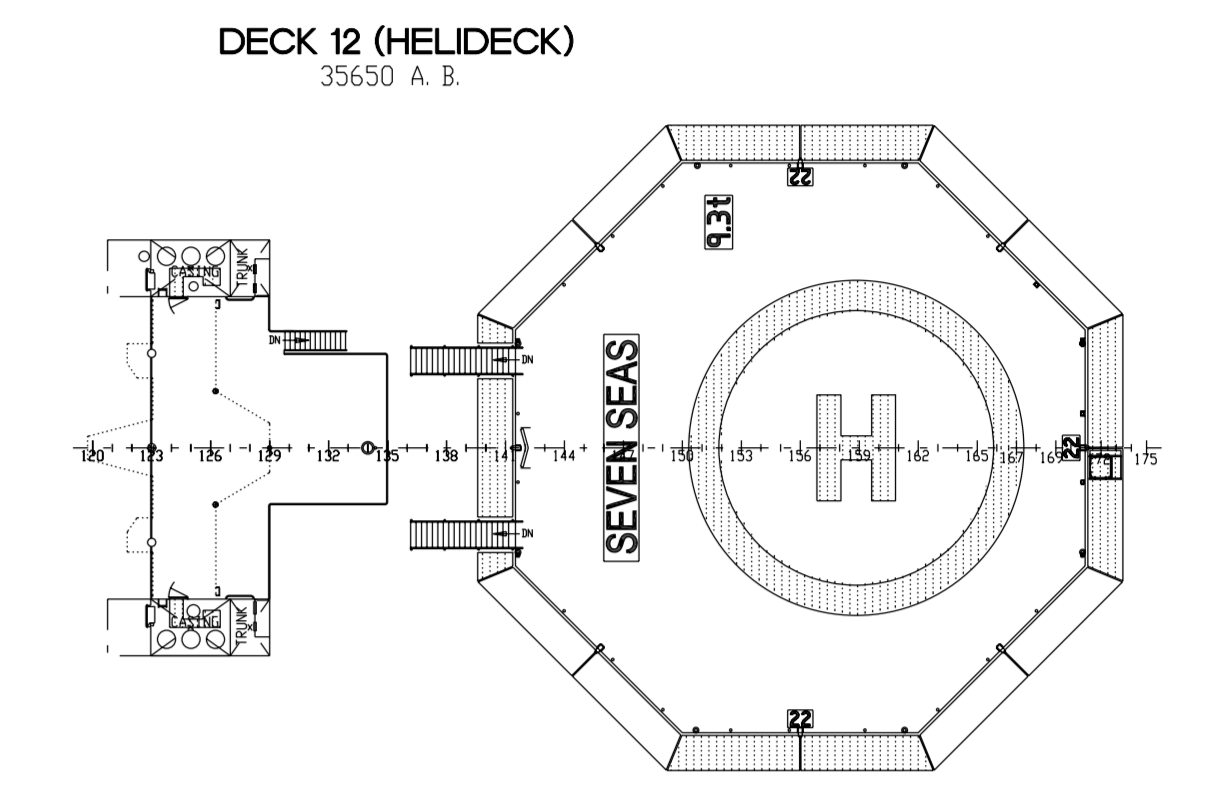
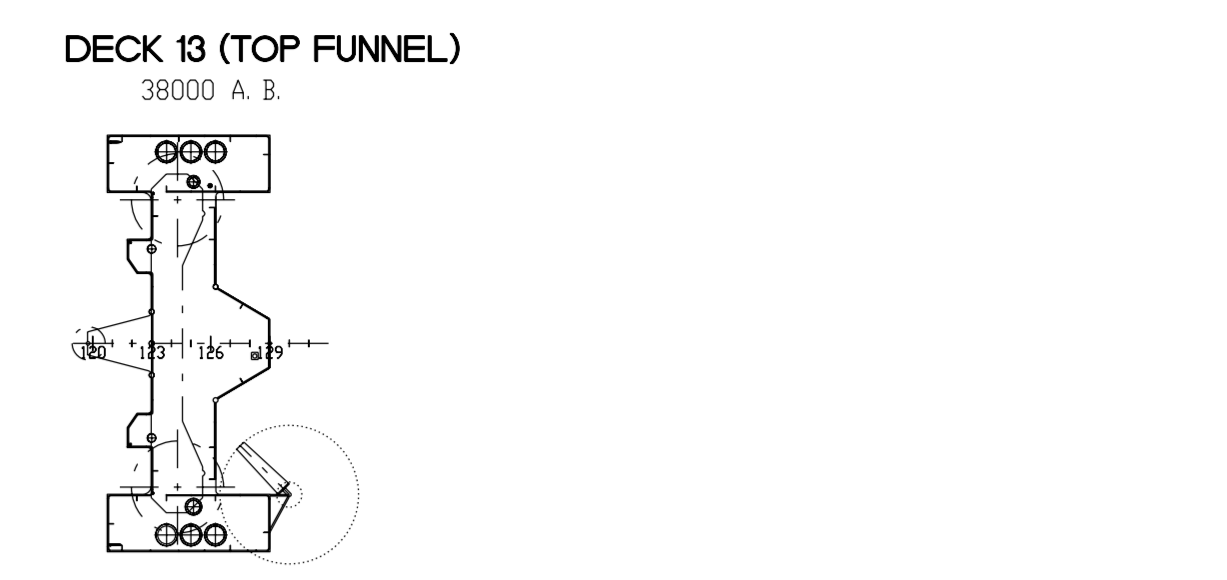
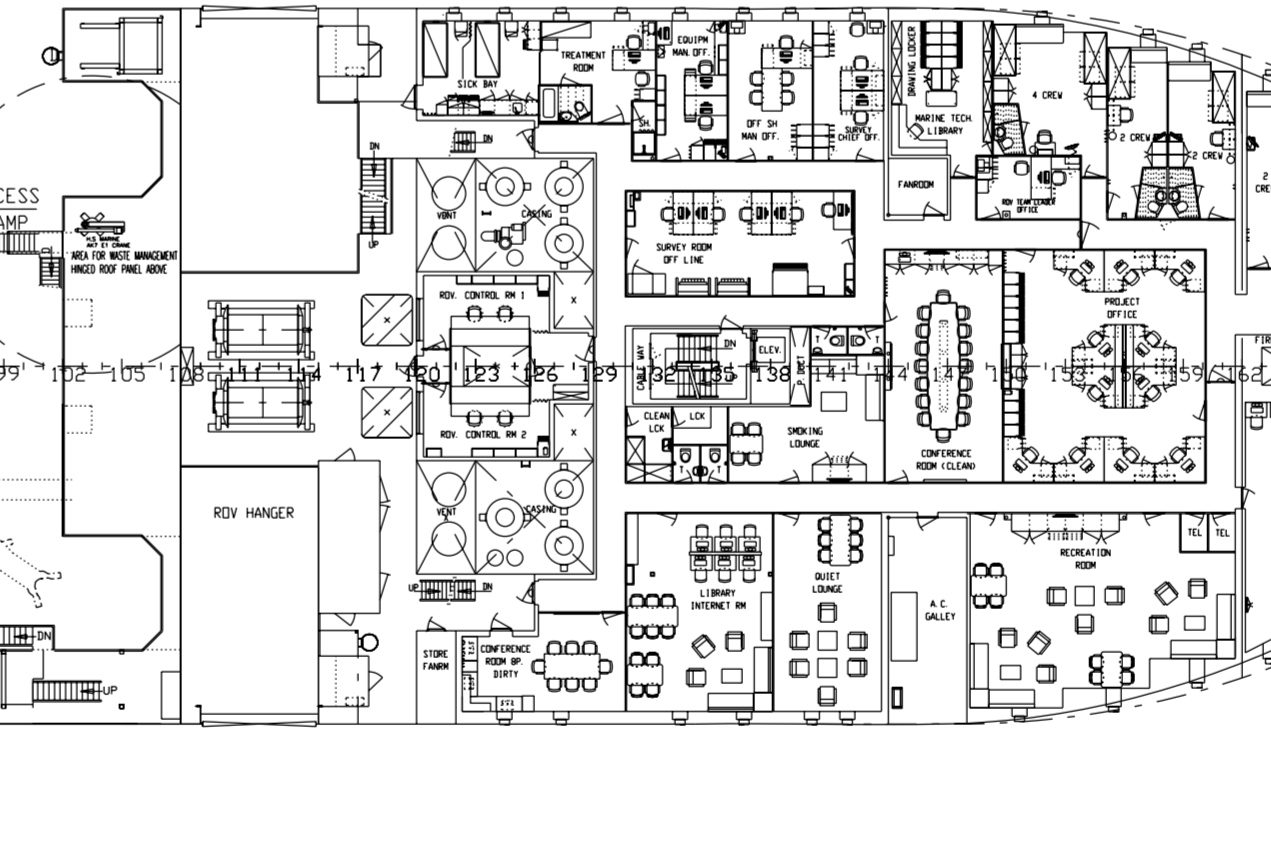
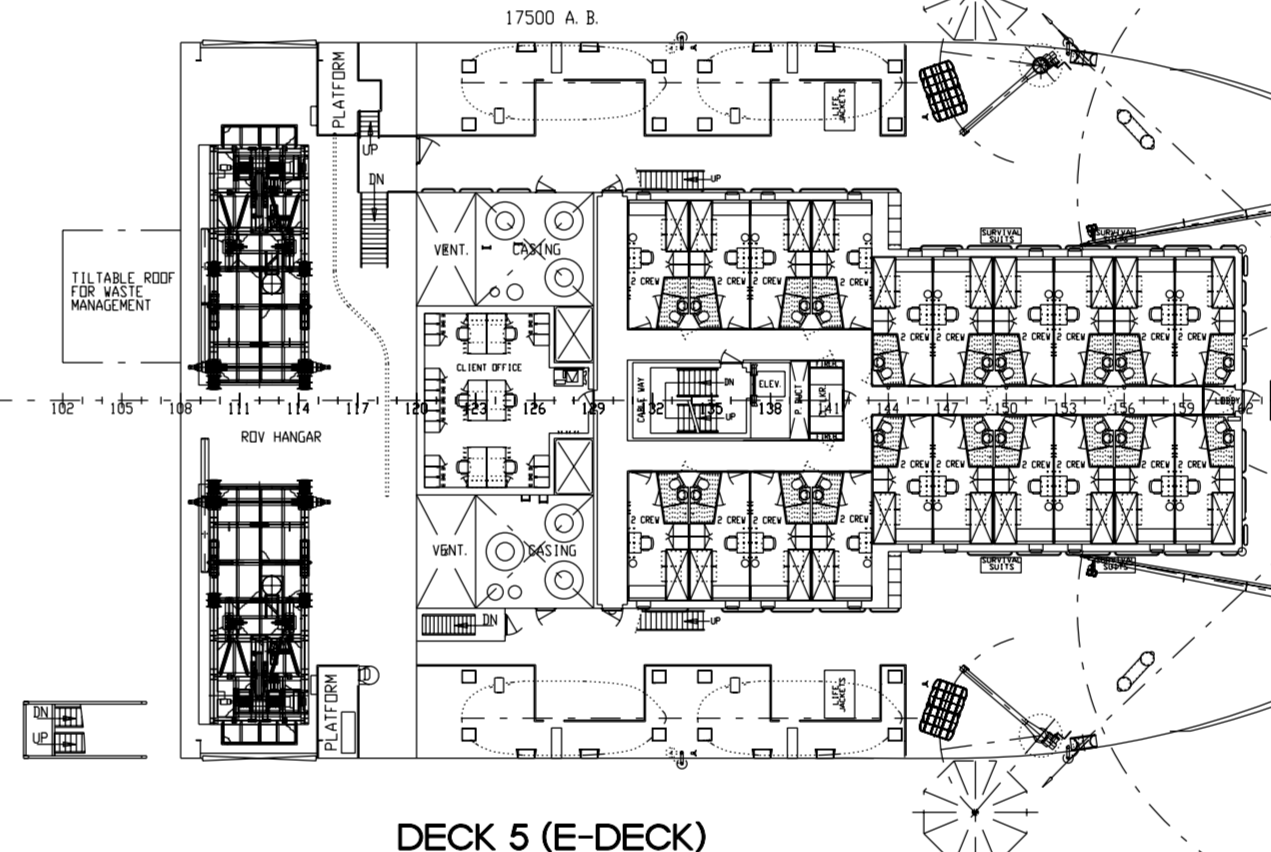
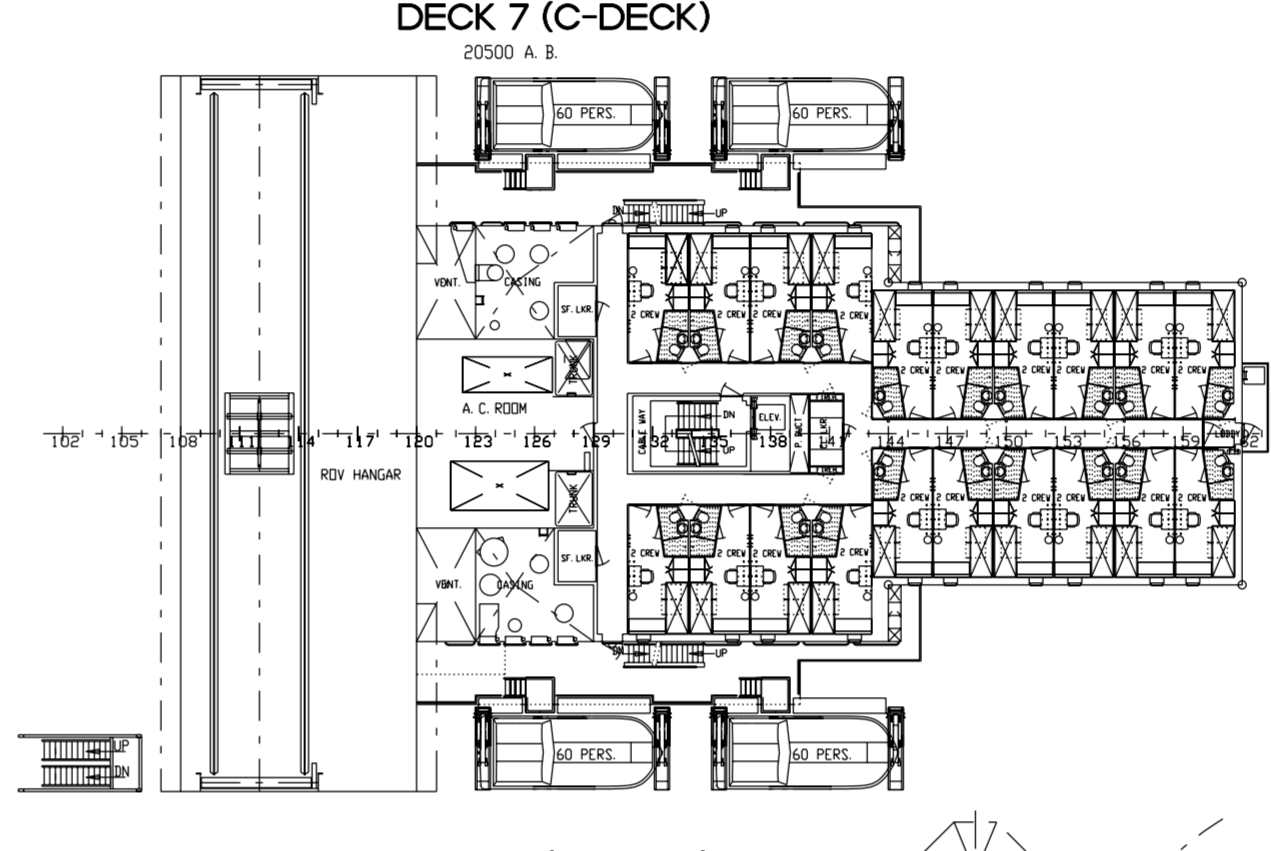
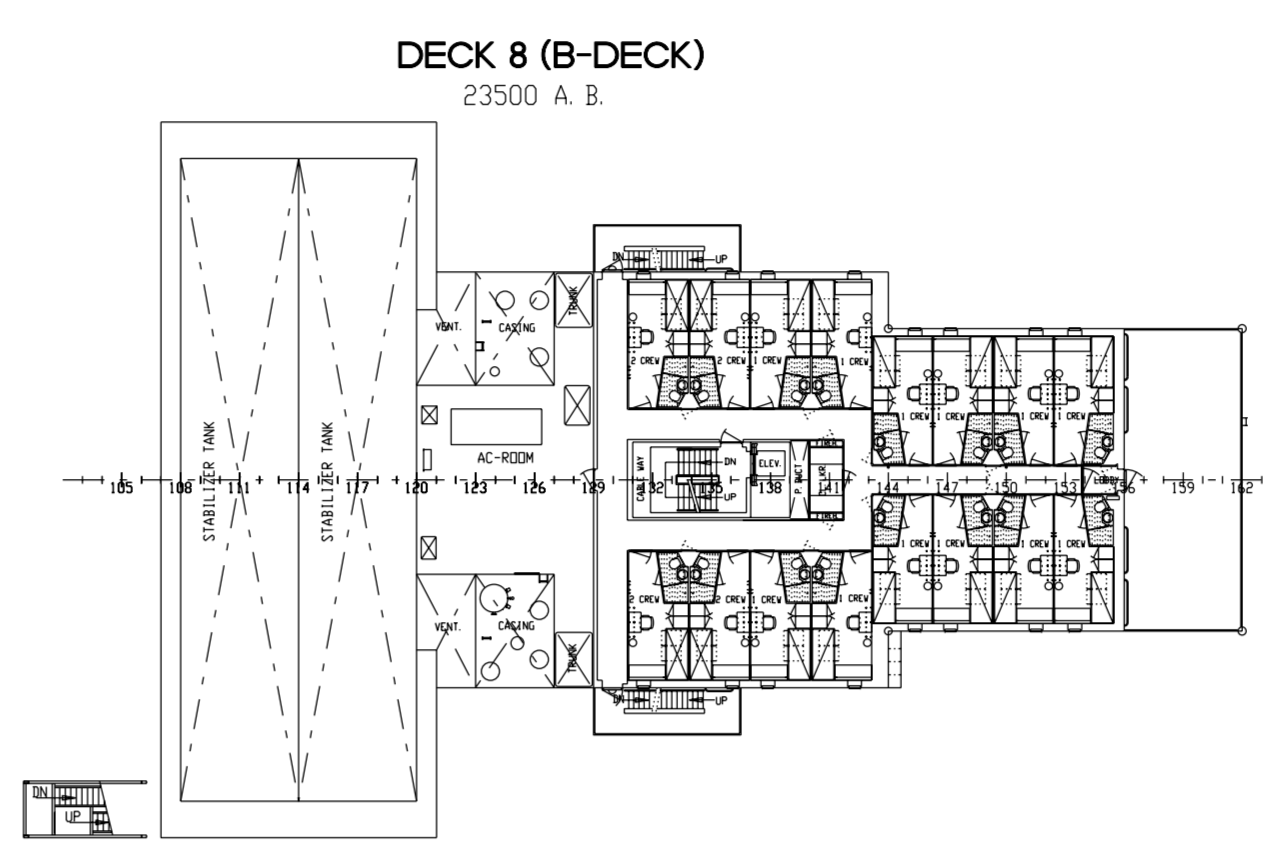
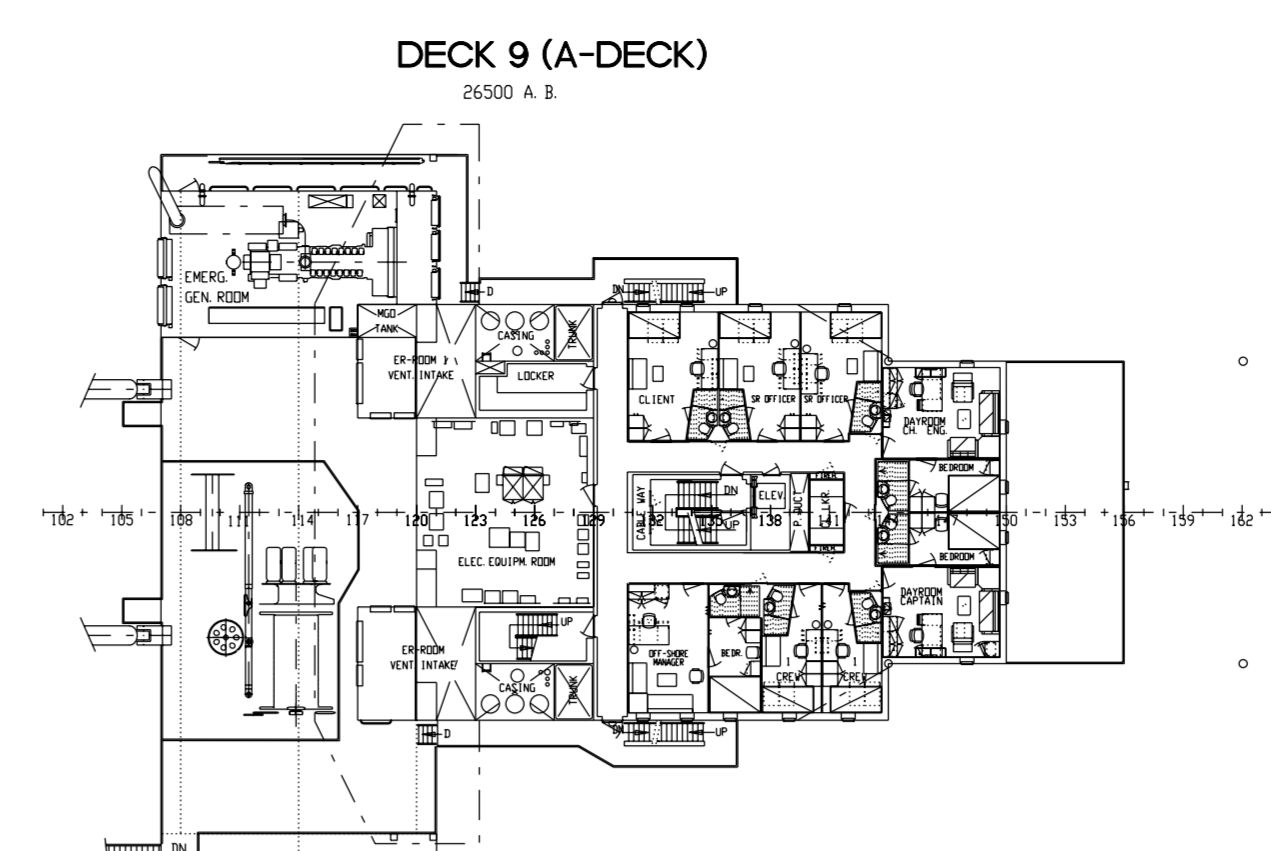

PRINCIPAL PARTICULARS

LENGTH O.A.	153.240 M.
LENGTH R.P.P.	142.080 M.
LENGTH W.L. (AT 7.500 M)	148.080 M.
BREADTH M.I.D.	28.400 M.
DEPTH MAINDECK	12.500 M.
DRAUGHT DESIGN	7.500 M.
DRAUGHT SCANTLING	6.000 M.

REV	DATE	REASON FOR ISSUE	KTK	Kik	SAJ
C1	05.02.10	GENERAL UPDATE			
			DRN	CHK	APPR
			BY	BY	BY

**subsea 7**

Subsea 7 owns the copyright of this document which is supplied in confidence and must not be used for any purpose other than that for which it is supplied and must not be reproduced without express permission in writing from the owners.

SCALE: U.O.S. 1:300 A0 DIMENSIONS IN mm U.O.S. SFI CODE: 101

THIS DRAWING REPLACES: 710-019.01

TITLE: SEVEN SEAS PIPE-LAY CONSTRUCTION VESSEL GENERAL ARRANGEMENT

DRG. NO.: 7Se-101\_710-019\_01-03 SHEET 1 of 1 REV C1

**MERWEDE**  
P.O. BOX 5  
3270 AA HANDELVELD-GIESSEN  
THE NETHERLANDS  
TELEPHONE: +31-86-677300  
TELEFAX: +31-86-677301  
EMAIL: m.p.yar@merwede.com

PIPE-LAY CONSTRUCTION VESSEL GENERAL ARRANGEMENT

SIZE	A0	DRAW. NR.	710-019.01
SCALE	1:300		
DRAWN	V. B. P.L.A.	10-04-06	PAGE NUMBER 3 NUMBER OF PAGES 3
CHECKED			REVISION   A   B   C

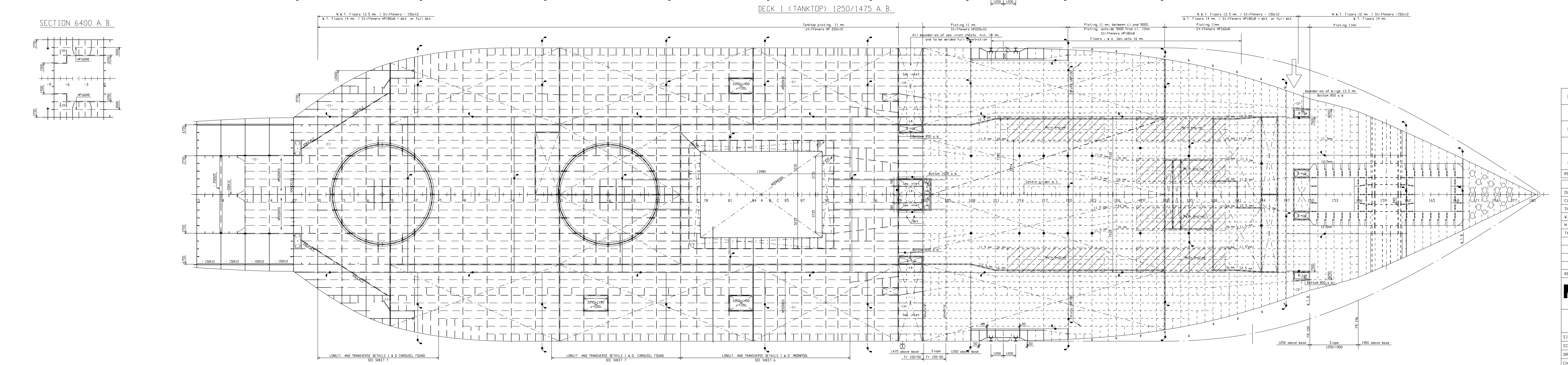
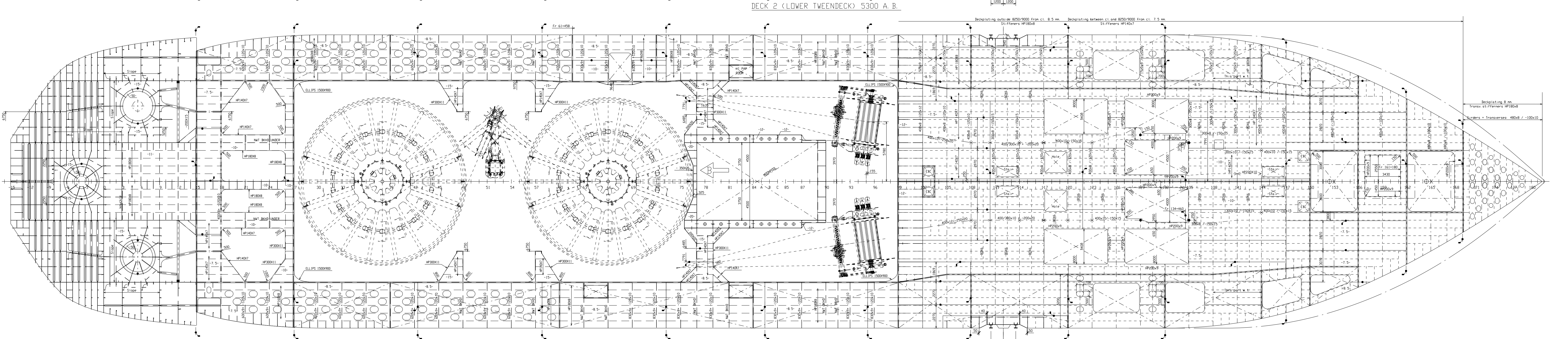
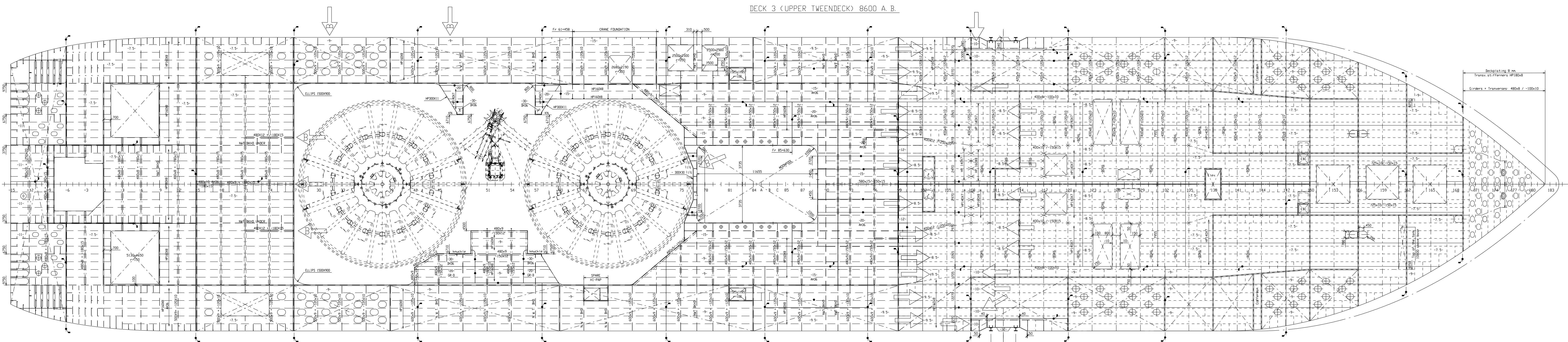

SECTION 6400 A.B.

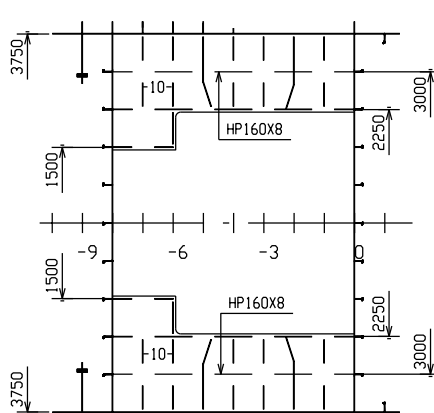

NOTE:  
 CONSTRUCTION FORSHIP F.W.D. FR. 100  
 REMAINS ALMOST THE SAME AS OUR PREVIOUS  
 VARENUMBER 709 REVISION D, EXCEPT OTHERWISE  
 INDICATED BY ARROW

E									
D									
C									
B	GENERAL UPDATE							08-06-06/08-06-06	EDS DJS
A	GENERAL UPDATE (NOT INDICATED BY ARROW)							09-05-06/09-05-06	EDS DJS
REV.	DESCRIPTION							DATE OF DISTRIBUTION	APPROVED
								16-05-2006	EDS
								22-05-2006	DJS
OWNER	24	24	24	24	24	24	24		
CLASS SOCIETY	24-04-06	24-04-06	24-04-06	24-04-06	24-04-06	24-04-06	24-04-06		
SHIPPING INSP.	24-04-06	24-04-06	24-04-06	24-04-06	24-04-06	24-04-06	24-04-06		
M.V.B.	24-04-06	24-04-06	24-04-06	24-04-06	24-04-06	24-04-06	24-04-06		
M.S.I.	24-04-06	24-04-06	24-04-06	24-04-06	24-04-06	24-04-06	24-04-06		
TKSB/TMB	24-04-06	24-04-06	24-04-06	24-04-06	24-04-06	24-04-06	24-04-06		

**MERWEDE**  
 shipyard

3370 AA HERTSHOVD-GIESSEN  
 THE NETHERLANDS  
 TELEPHONE +31 184-677300  
 TELEFAX +31 184-677301  
 EMAIL shipyard@merwe.de

**CONSTRUCTION PLAN**  
 DECK 1 - 2 - 3

SIZE A0/LANG14 DRAW NR. 710-109.02  
 SCALE 1:125  
 DRAWN EDS 24 04 06 PAGE NUMBER 1 NUMBER OF PAGES 8  
 CHECKED DJ vol S 24 04 06 REVISION A B

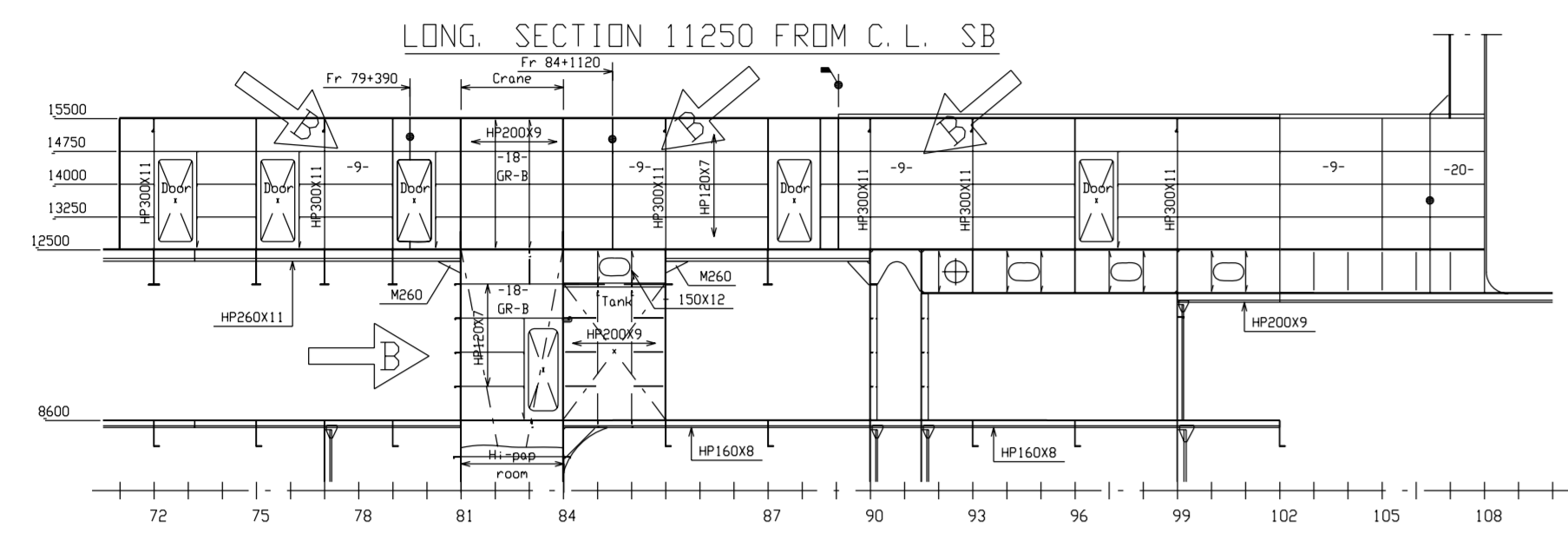

SECTION 15500 A. B.

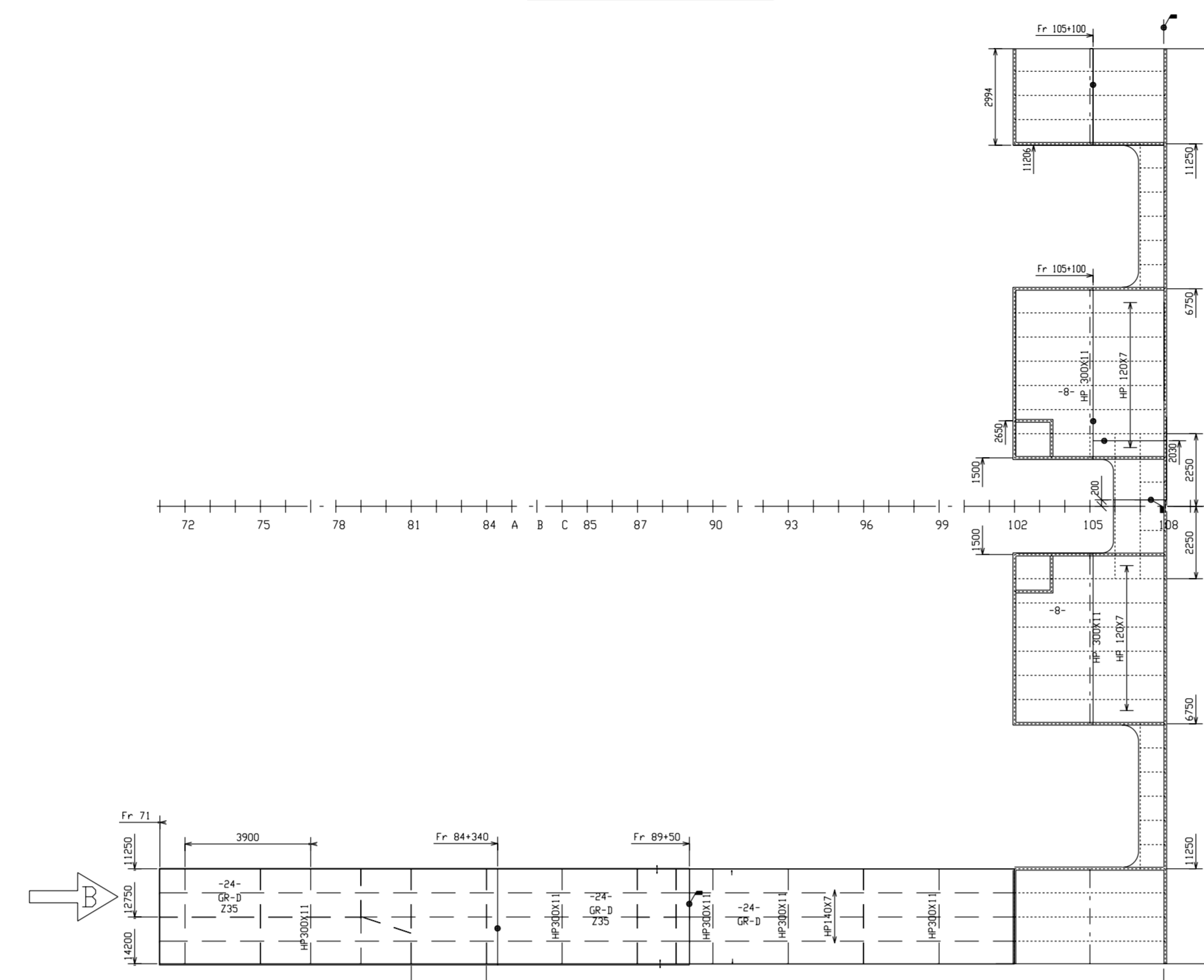

DECK 6 (D-DECK) 17500 A. B.

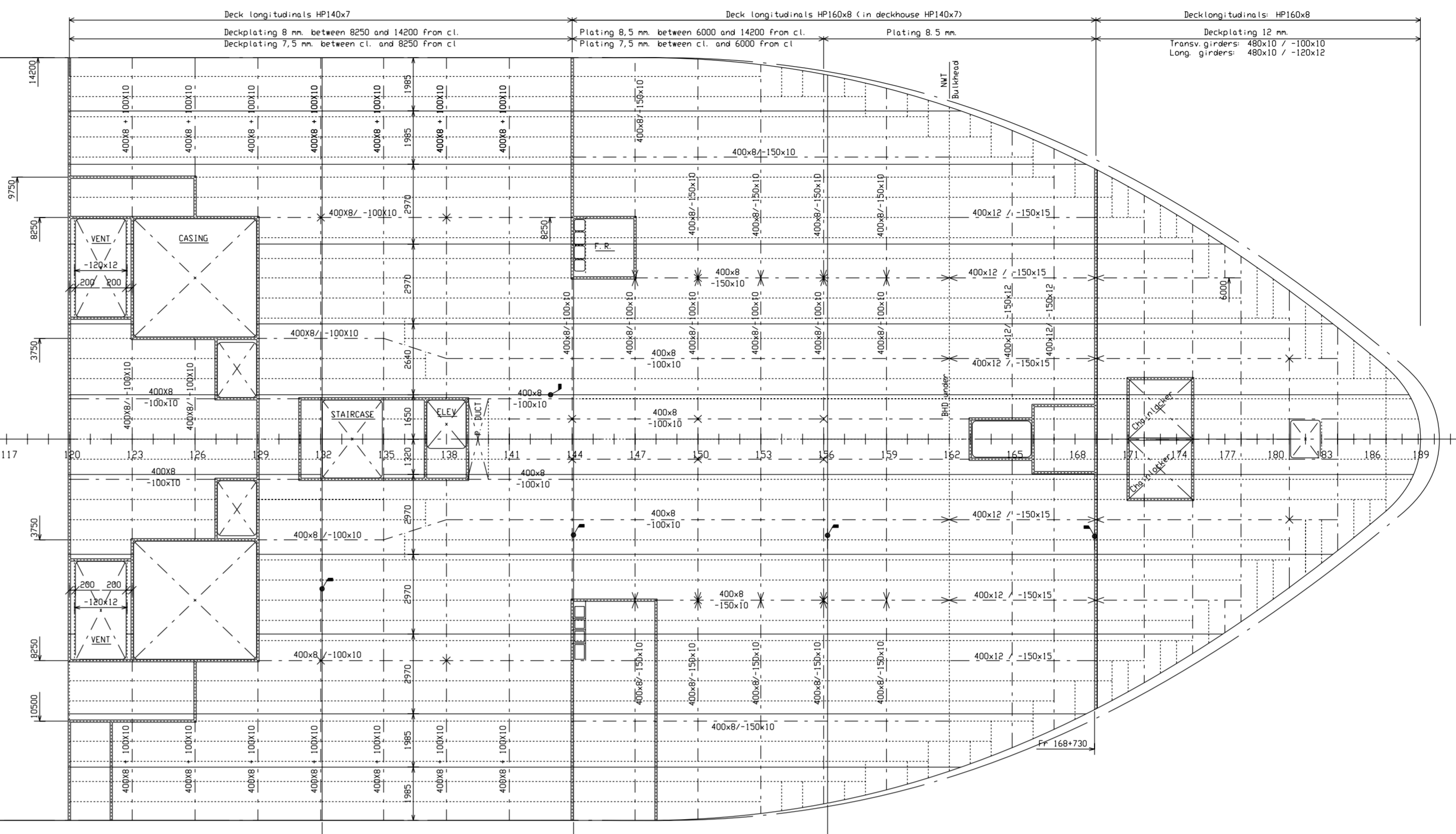

DECK 5 (E-DECK) 14500 A. B.

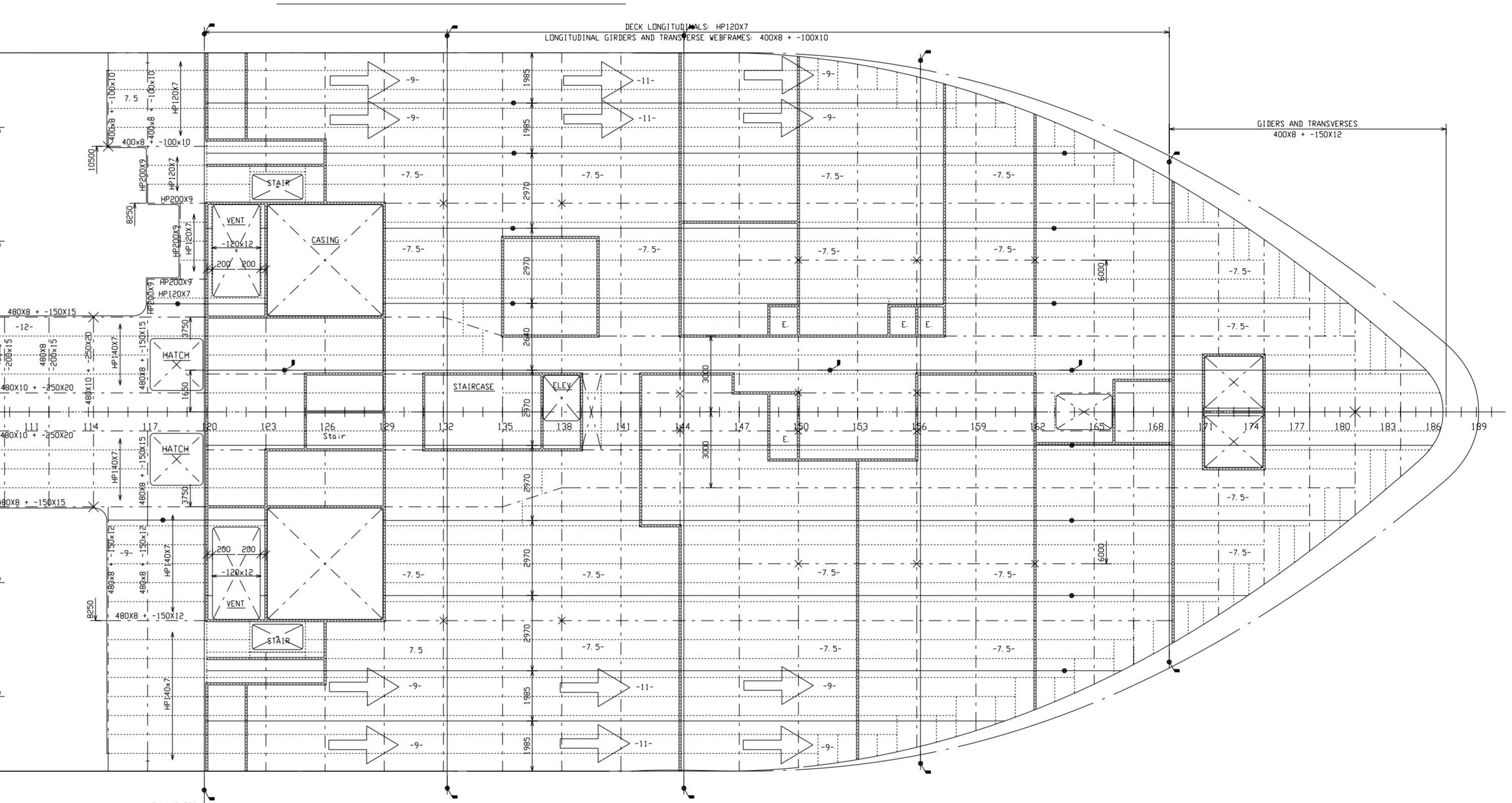

SECTION 10775 A. B.  
I. W. O. COFFERDAM

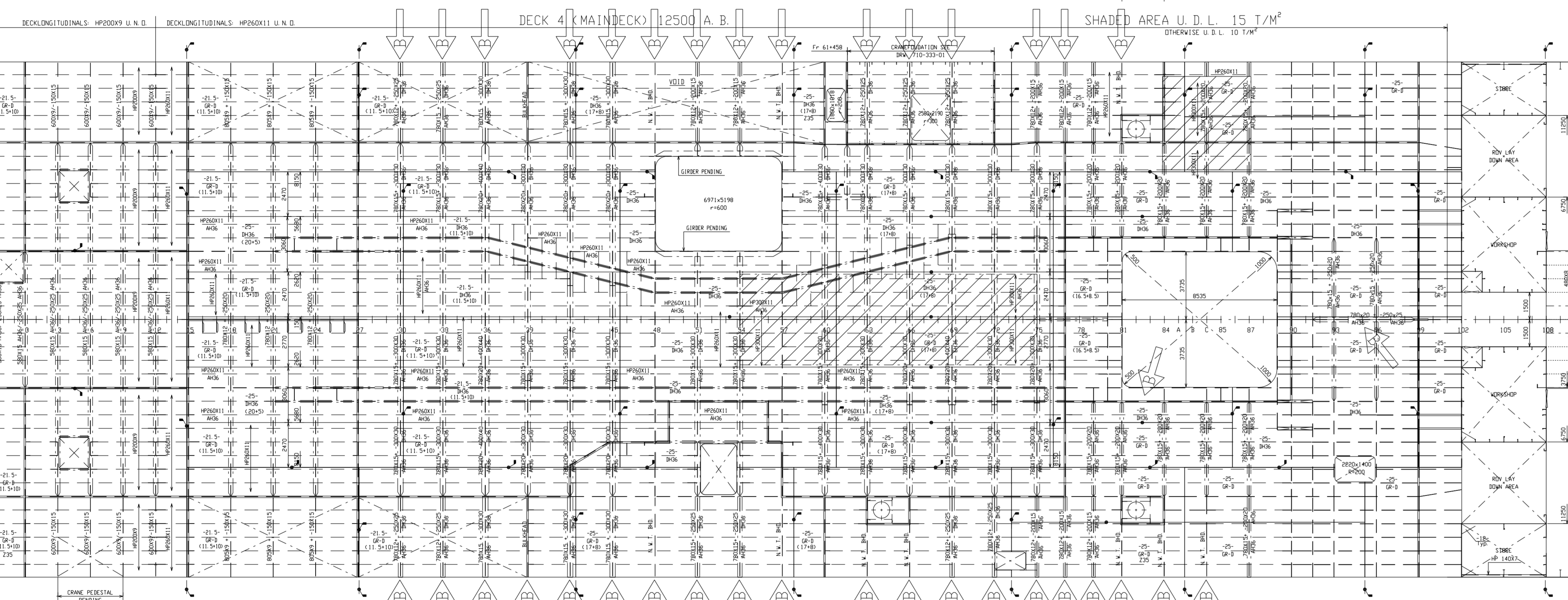
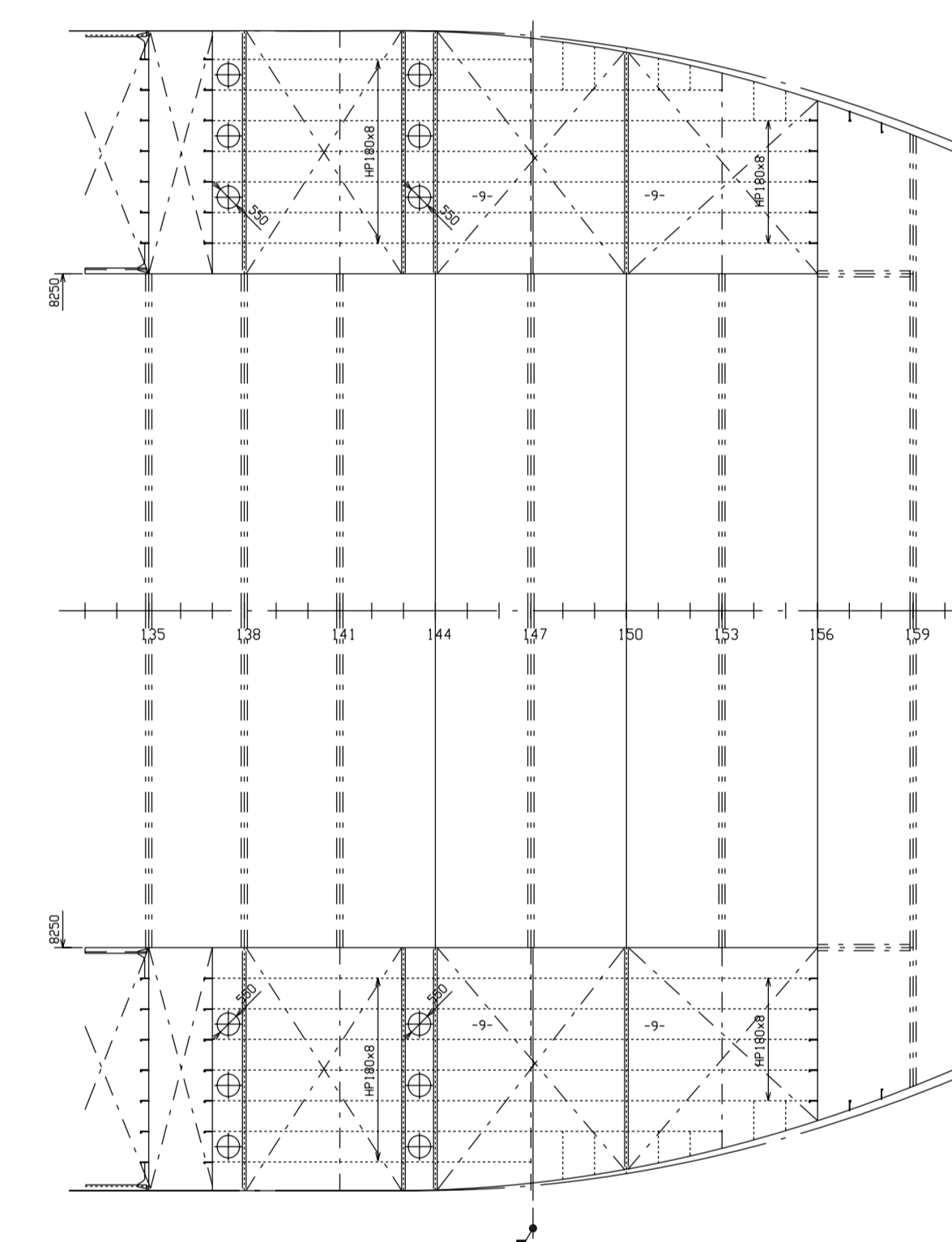

DECK 4 (MAINDECK) 11500 A. B.

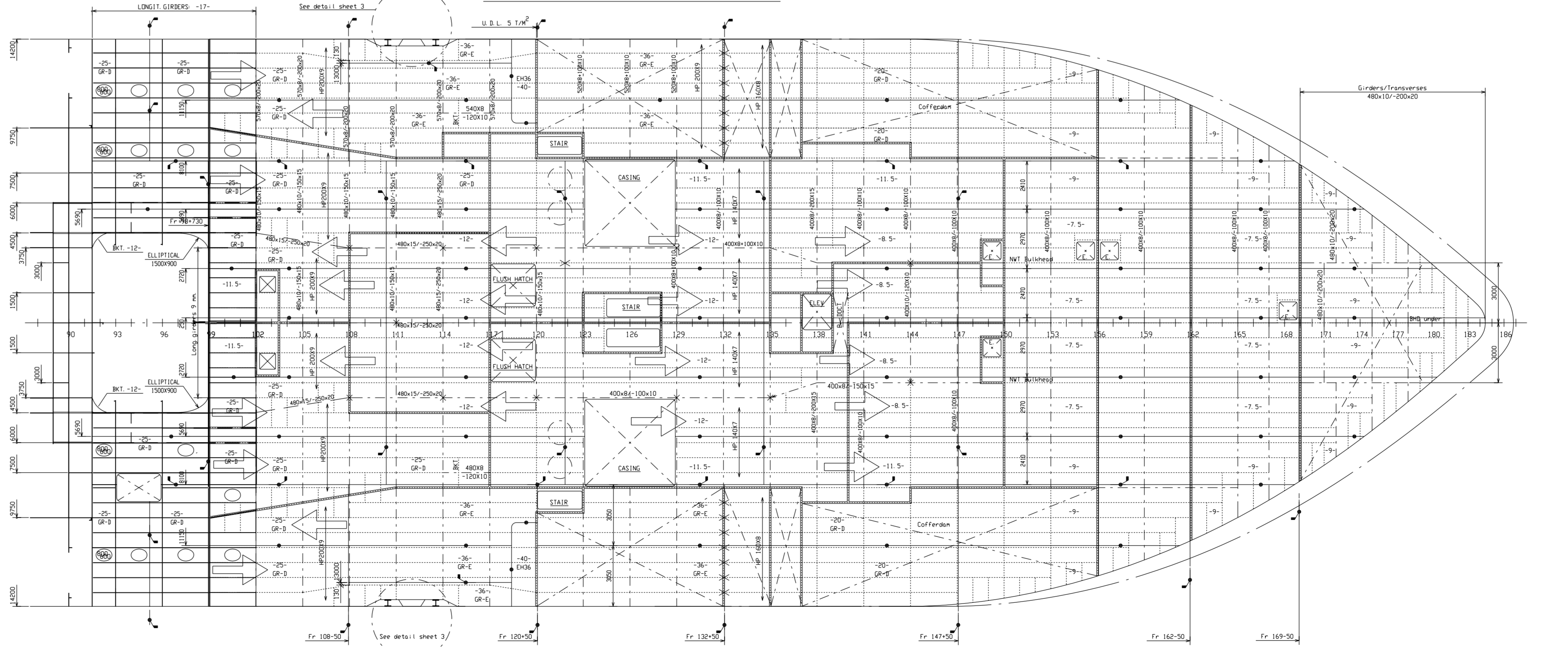

SECTION 10160 A. B.

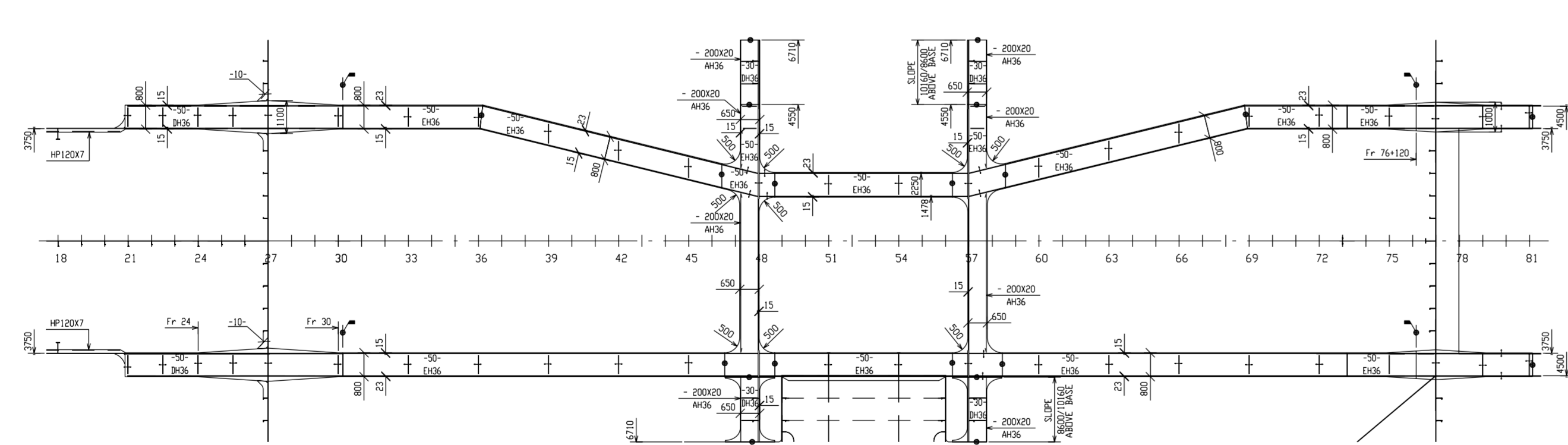

NOTE:  
CONSTRUCTION FORESHIP FWD FR 102  
REMAINS ALMOST THE SAME AS OUR PREVIOUS  
YARDNUMBER 703 REVISION D, EXCEPT OTHERWISE  
INDICATED BY ARROW.

REV	DESCRIPTION	DATE OF DISTRIBUTION	APPROVES
E			
D			
C			
B	GENERAL UPDATE	08-04-06/08-04-06	EDS DJS
A	GENERAL UPDATE (NOT INDICATED BY ARROW)	09-05-04/09-05-04	EDS DJS
REV	DESCRIPTION	DATE OF DISTRIBUTION	APPROVES
DWNR	25-05-04	16-05-2006	
CLASS SOCIETY	2-54 (R-55)	22-05-2006	
SHIPPING INSP	13		
W. I. B.	2-54 (R-55)		
H. A. I.	13		
TKS/PAMB	2-54 (R-55)		
REVISION	A B C D E F G H		

**MERWEDE** shipyard

3070 AA HARTSWELD-GIESSENDAAM  
THE NETHERLANDS  
TELEPHONE : +31 184-677300  
TELEFAX : +31 184-677301  
EMAIL : shipyard@merwede.com

**CONSTRUCTION PLAN**  
DECK 4 - 5 - 6

SIZE: ADLANGIS DRAW NR. 710-109.02  
SCALE: 1:125  
DRAWN: EDS 24.04.06 PAGE NUMBER: 2 NUMBER OF PAGES: 9  
CHECKED: D.J. vd S 24.04.06 REVISION: A B

SECTION FRAME 113+400 LONG. SECTION 13130 FROM C.L. PS

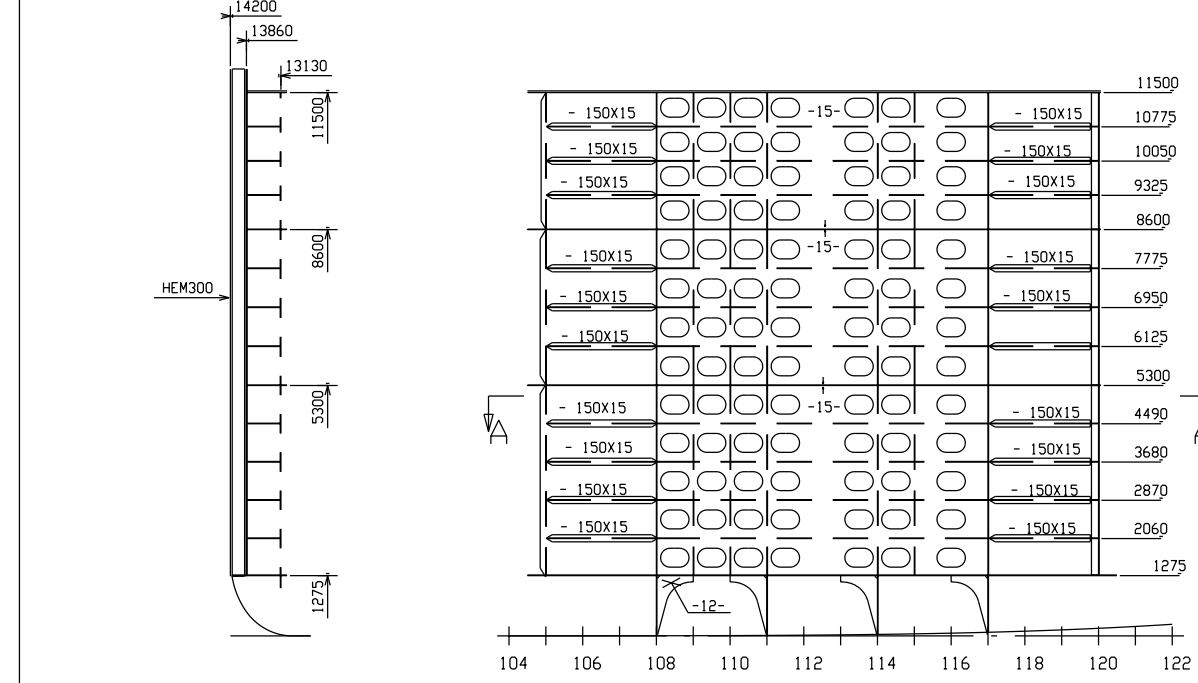

SECTION A-A

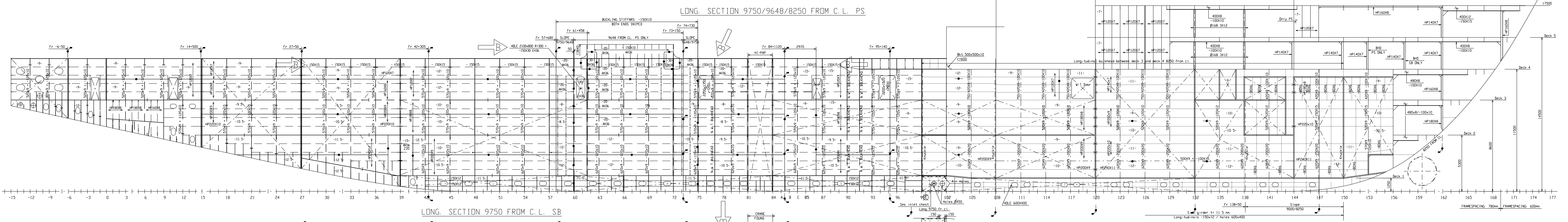
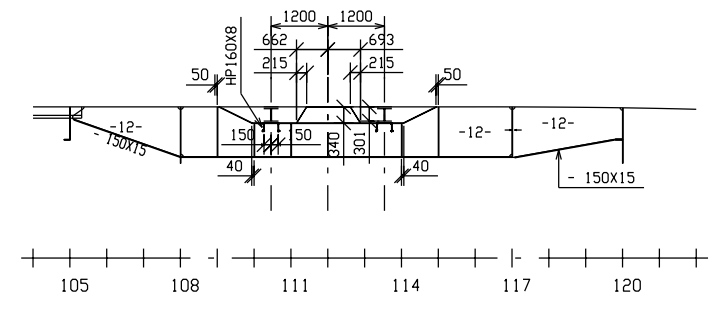

LONG. SECTION 9750 FROM C.L. SB

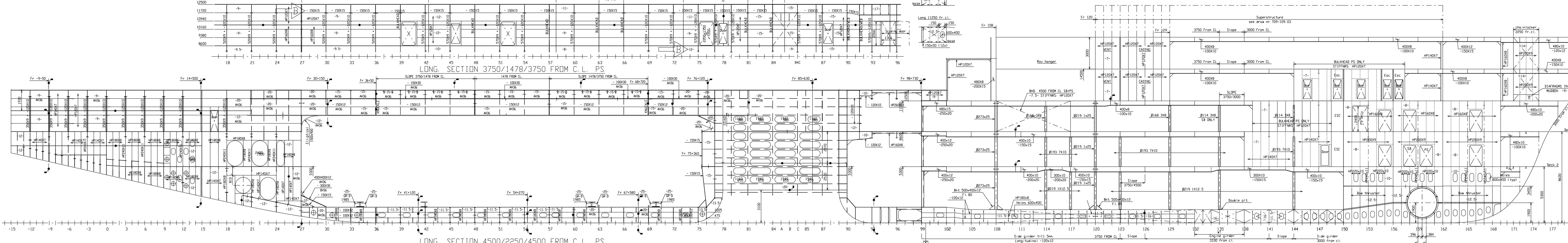
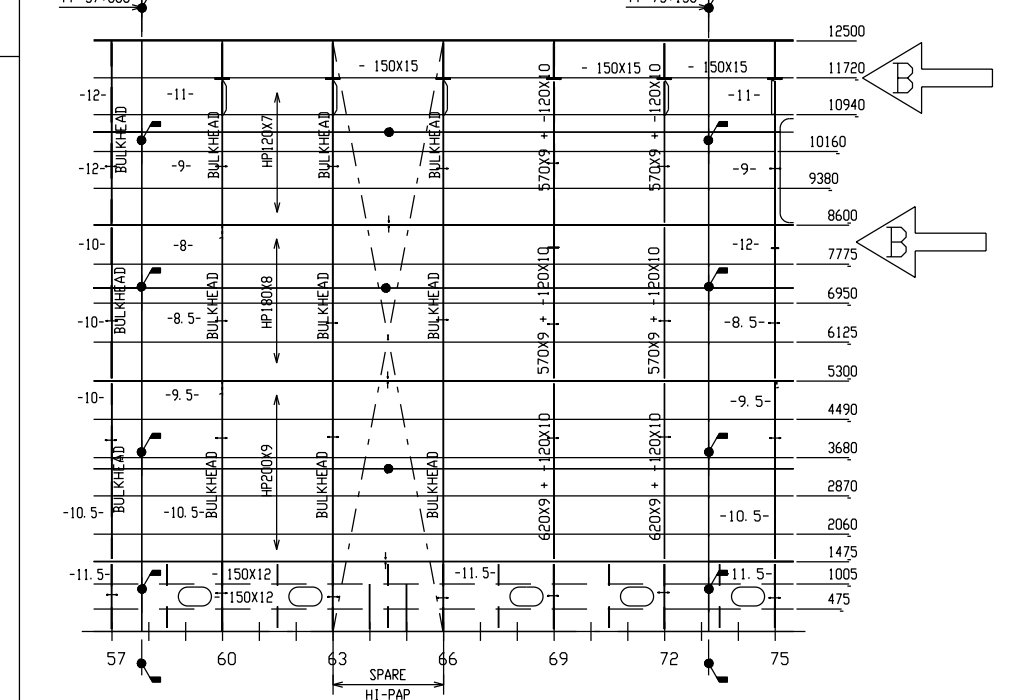

LONG. SECTION 3750 FROM C.L. SB

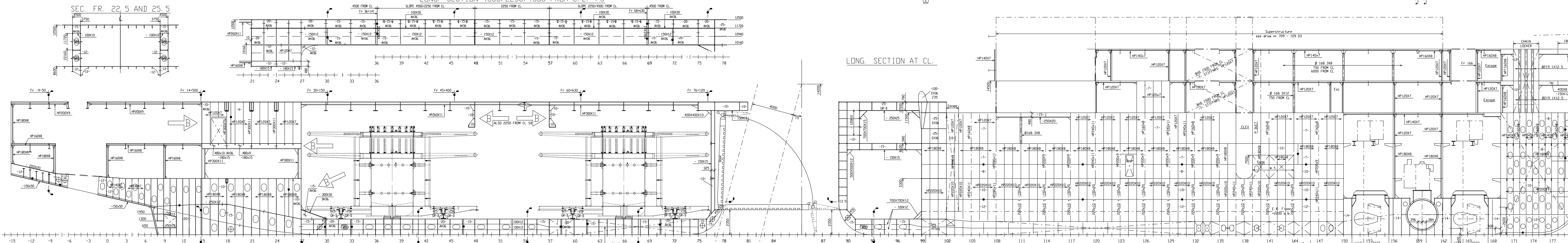
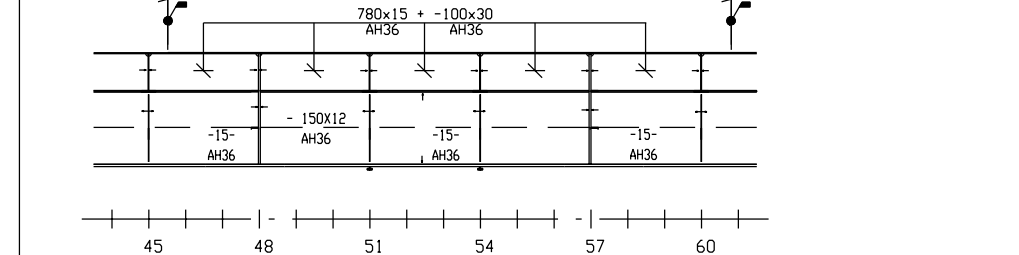

LONG. SECTION 4500 FROM C.L. SB

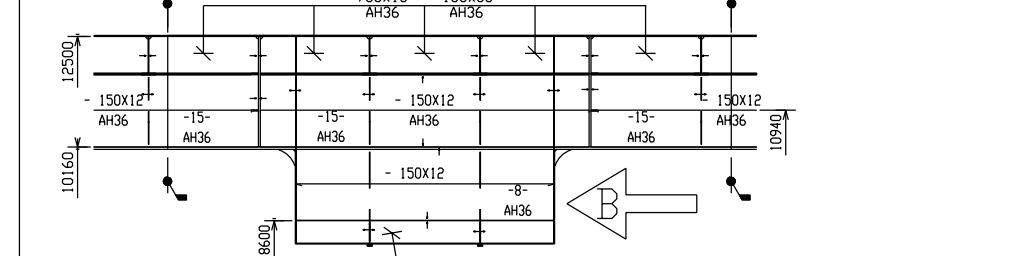

LONG. SECTION 6750 FROM C.L. SB

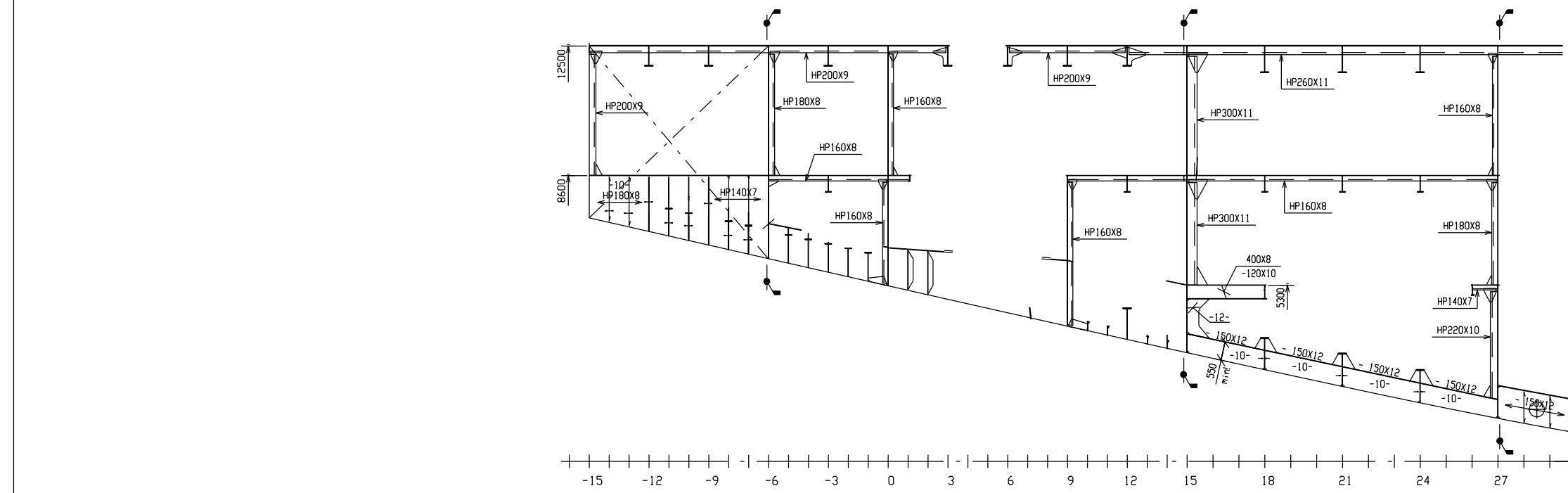
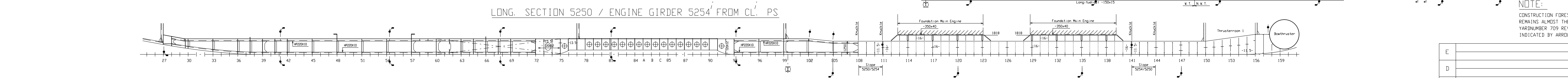
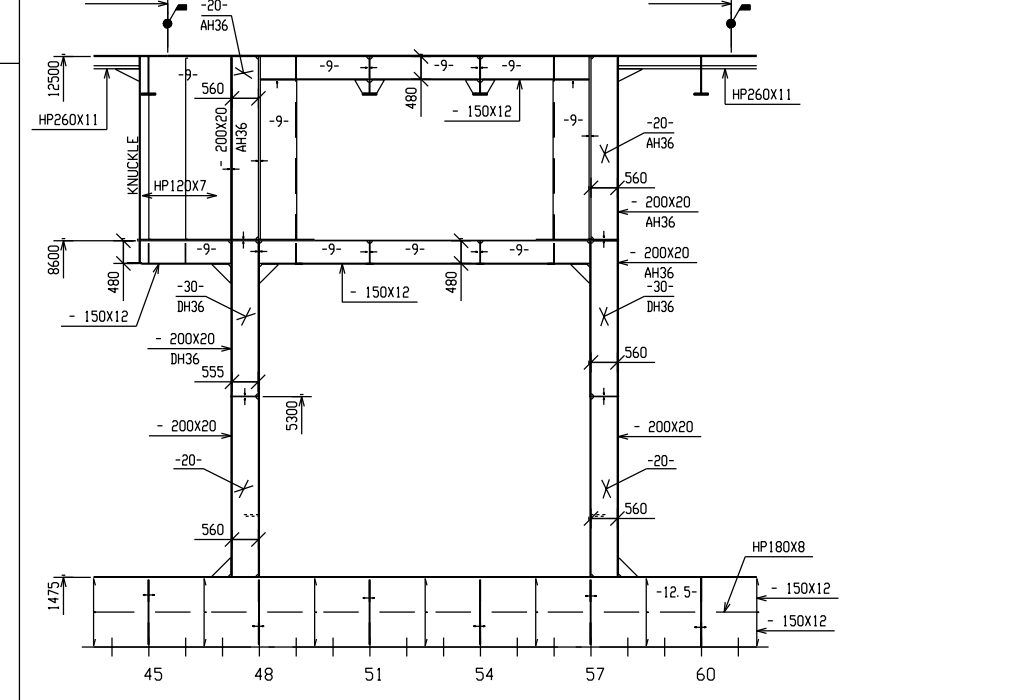

LONG. SECTION 12000 FROM C.L. PS

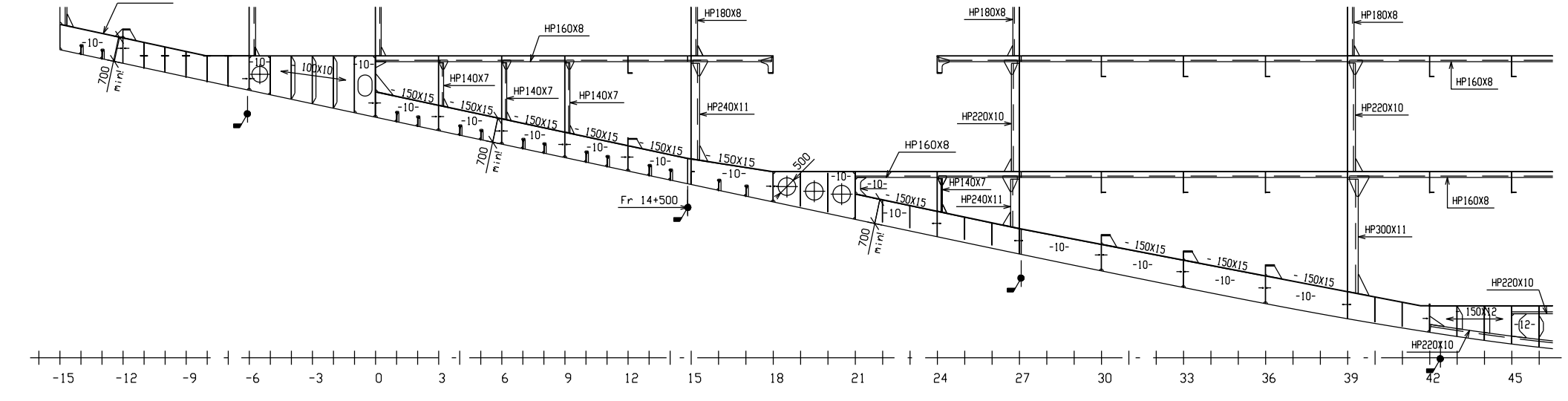

LONG. SECTION 1250 / ENGINE GIRDER 1254 FROM C.L. - PS

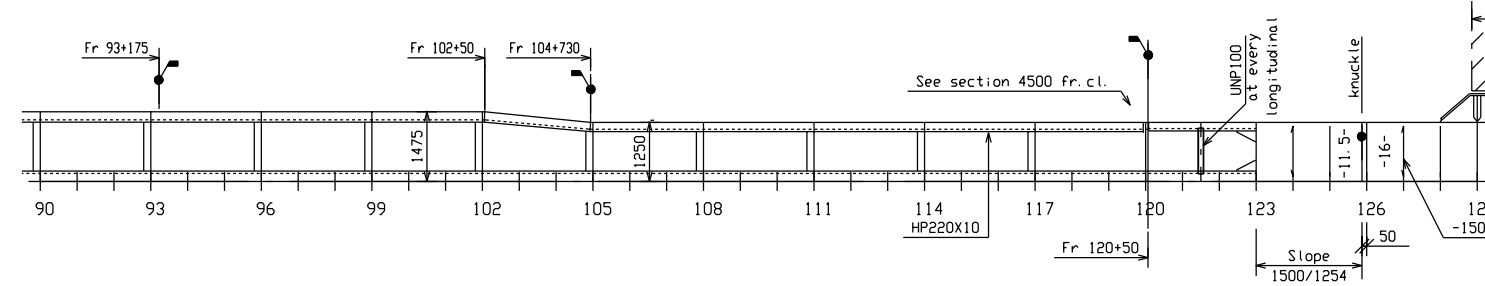

LONG. SECTION 3750 FROM C.L. SB (TYP)

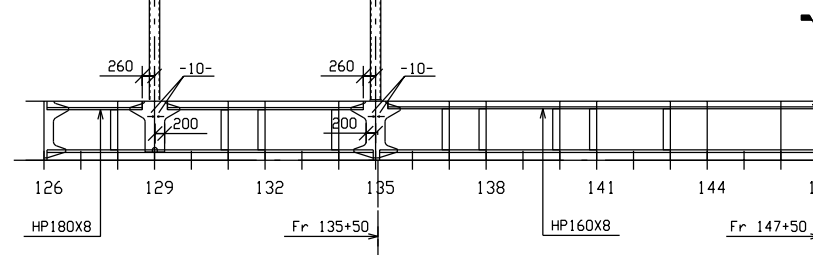

LONG. SECTION 4500 FROM C.L. SB (TYP)

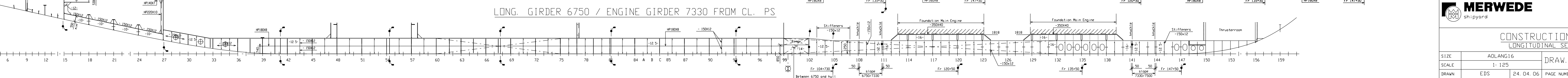
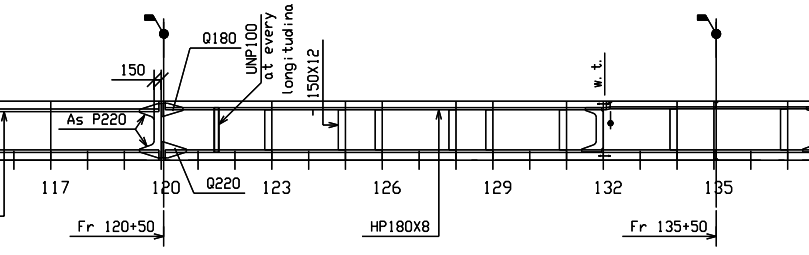

NOTE:  
CONSTRUCTION FORESHIP #10 PS 10  
SHOWING ALMOST THE SAME AS OUR PREVIOUS  
HARDNUMBER 709 REVISION D, EXCEPT OTHERWISE  
INDICATED BY ARROW

E									
D									
C									
B	GENERAL UPDATE							08-06-06/08-06-06	EDS DJS
A	GENERAL UPDATE (NOT INDICATED BY ARROW)							09-05-06/09-05-06	EDS DJS
REV	DESCRIPTION							DATE OF DISTRIBUTION	APPROVAL
OWNER	CLASS SOCIETY	SHIPPING INSP.	M & I	TKSB/TKMB				15-05-2006	22-05-2006
REVISION	A	B	C	D	E	F	G	H	
		P.O. BOX 5 2270 AN HANDELWEG-GIESENDAH 2270 AN HANDELWEG-GIESENDAH TELEPHONE: +31 184-677300 TELEFAX: +31 184-677301 EMAIL: info@merwede.com							
CONSTRUCTION PLAN LONGITUDINAL SECTIONS									
SIZE	A0/LANG16		DRAW. NR. 710-109.02						
SCALE	1:125								
DRAWN	EDS	24.04.06	PAGE NUMBER	3	NUMBER OF PAGES	8			
CHECKED	DJ-vb-S	24.04.06	REVISION	A   B					

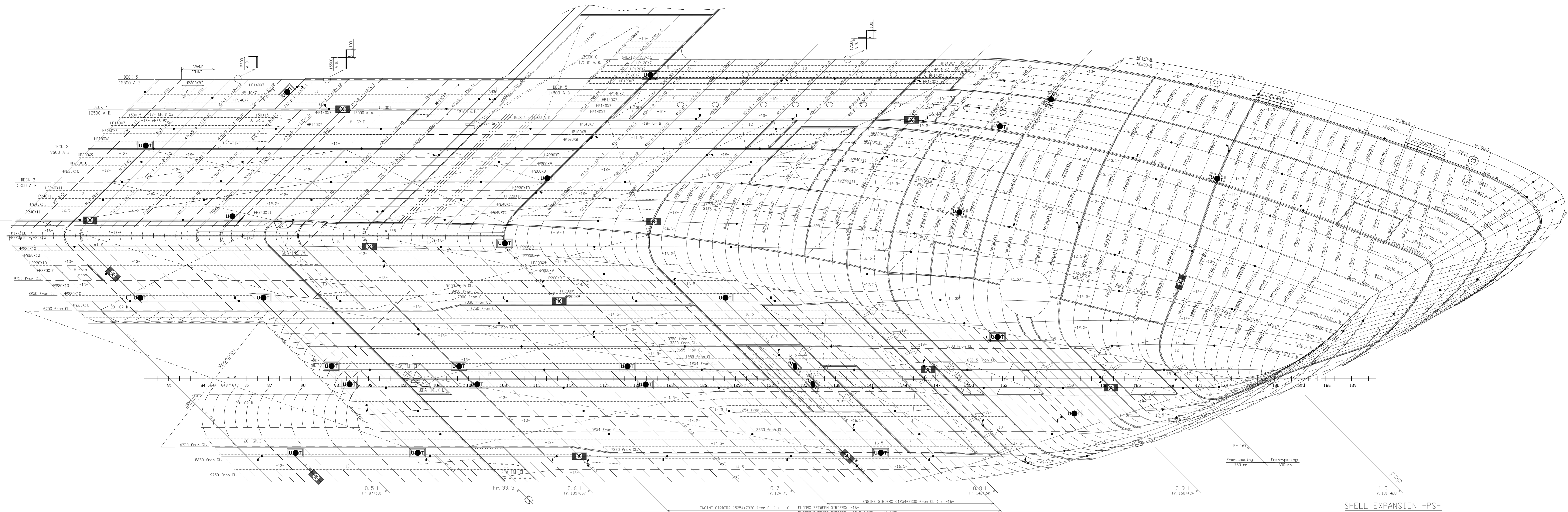

**SHELL EXPANSION -PS-**  
BECKING STIFFNESS -150010  
BOTH ENDS SHIP

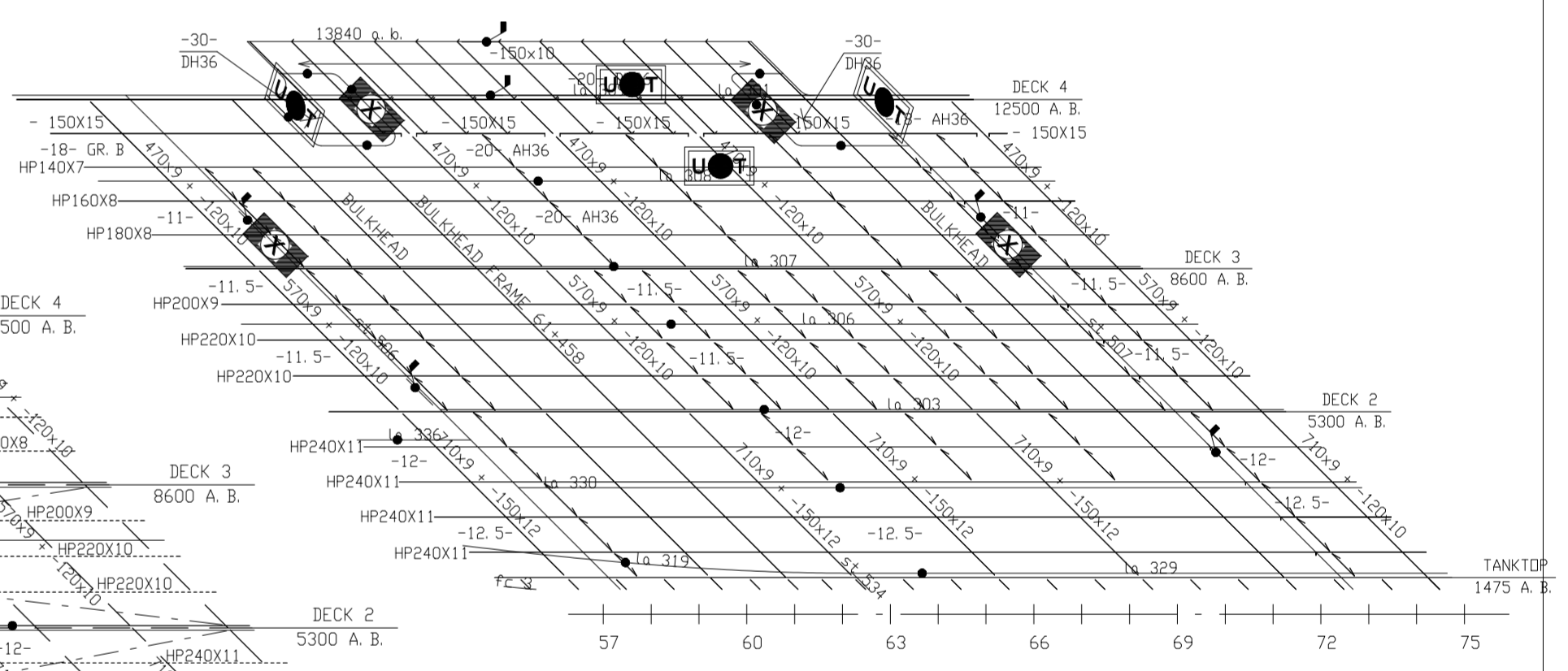

NOTE:  
CONSTRUCTION FORESHIP FWD. FRAME 102  
REMAINS ALMOST THE SAME AS OUR PREVIOUS  
YARDNUMBER 709 REVISION D.

MIN. DRAUGHT FORWARD: 4500 mm

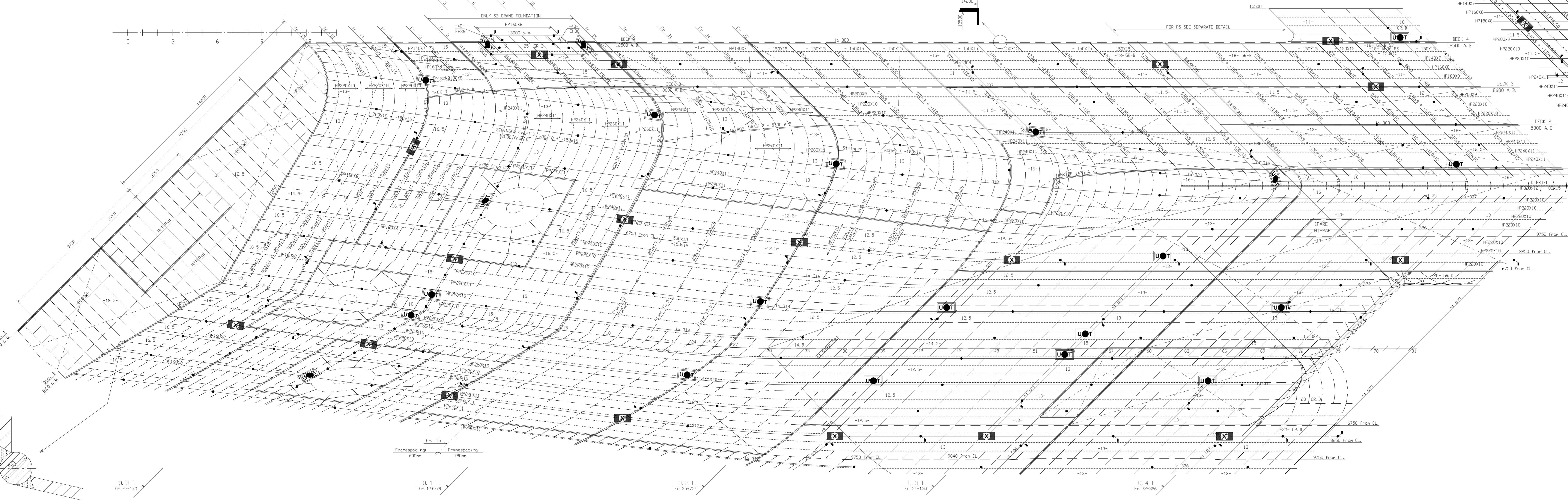

**SIDEVIEW SKEG**

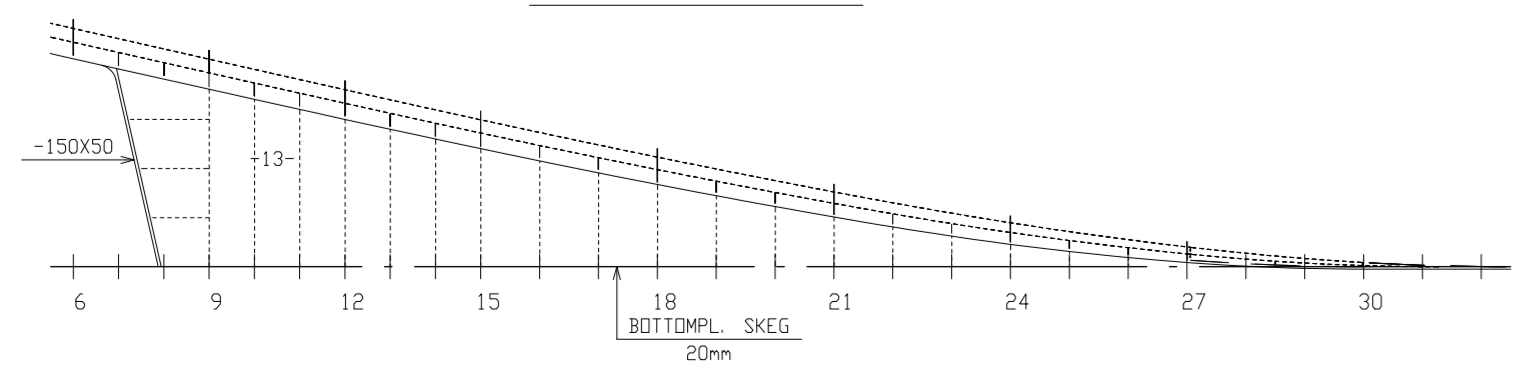

E			
D			
C			
B			
A			
REV.	DESCRIPTION	DRAWN	CHECKED

OWNER	DATE OF DISTRIBUTION	APPROVED
CLASS: SOCIETY		
BL.		
W.V.B.		
LASSERS		
SHIPPING INSP.		
MTECH. INSP.		
PIPING INST. E.R.		
PIPING INST. ACCOM.		
REVISION	0	B C D E F G H

**MERWEDE**  
SHIP-YARD

P.O. BOX 5  
5370 A.A. HARDINXVELD-GIESSENDAM  
THE NETHERLANDS  
TELEPHONE: +31 184-677300  
TELEFAX: +31 184-677301

**NDT/WELDING CONTROL SHELL EXPANSION**

SIZE	A0	DRAW.NR.:	710 - 109.22
SCALE	1:100	PAGE NUMBER:	20
DRAWN	C. G. de Hoog	REVISION	
CHECKED		NUMBER OF PAGES:	21