



University of Stavanger

Faculty of Science and Technology

**MASTER'S THESIS**

Study program/ Specialization: Petroleum technology - Drilling	Spring semester, 2012  Open
Writer: Nils Oskar Berg Njå	..... (Writer's signature)
Faculty supervisor: Bernt Sigve Aadnøy External supervisor: Martin Straume	
Titel of thesis:  P&A of Valhall DP wells	
Credits (ECTS): 30	
Key words: P&A, Valhall, Technology, Collapse, Well design	Pages: 105  + enclosure: 10  Stavanger, 05.06.2012 Date/year

**Abstract**

The original platforms on the Valhall field will have to be decommissioned due to integrity issues. The oldest drilling platform, Valhall DP, has 30 wells that must be P&A in order to remove the platform. This thesis examines the challenges for P&A of the Valhall DP wells. To understand why the Valhall DP wells have to be P&A-ed, a detailed field description has been given, especially with regard to compaction and subsidence. Both internal BP regulations and NCS regulations have been evaluated and compared. Alaskan regulations have been compared as well to show the differences between different regulatory regimes. In order to P&A the Valhall DP wells according to NCS and BP regulations, new technology will have to be invented. A review of new technology, non commercialized technology and new plugging materials has therefore been included. A proposal for a general P&A plan has also been included.

Compaction of the Valhall reservoir has led to seabed subsidence and overburden collapse in many wells. To avoid (or delay) collapse of wells, heavy wall liner overlaps has been implemented. Annulus barriers are often lacking in the region where the overlapping heavy wall liner is located. BP regulations state that the secondary reservoir plug has to be deep enough so that the pressure from below does not fracture the formation on top of it. At the Valhall field, this means that reservoir plugs must be set below / in the region where the wells collapse and where the overlapping heavy wall liner is. Regulations also state that well barrier plugs shall cover all possible leak paths, both in horizontal and vertical direction. To set competent well barrier plugs can become a complex and time consuming operation, and new technology will have to be invented to cope with these challenges.

Based on the thesis, some aspects have been found that may be improved in the future:

- Some P&A challenges could be avoided if there was more focus on P&A when designing and drilling new wells.
- Specialized P&A rigs could decrease the cost of P&A and increase the number of production wells drilled.

- Innovating service companies must get support through funding and implementation from big oil companies. Although several oil companies are already funding projects, there is still some reluctance to implementing new technology. History has proved that courageous oil companies can achieve value adding cost efficiency through implementation of new technology.
- To give P&A more attention at universities would give students increased awareness of the challenges for P&A in the future. This could help changing some of the present focus (or lack of focus) in the industry on P&A when designing and drilling new wells, and also help solving some of the challenges present.

**Acknowledgements**

I would like to use this opportunity to say thank you to several people who have given valuable contribution to this thesis. I have been working with the thesis in BP's office at Forus. I would like to express my gratitude to BP for giving me the opportunity to write this thesis and use their office.

My supervisor and mentor in BP, Martin Straume, for guidance, information, encouragement and for providing excellent feedback. He has given me a lot of motivation to keep working with P&A on a later stage.

My supervisor at the University of Stavanger, Bernt S. Aadnøy, for challenging me to explore several aspects of P&A.

P&A Interface Coordinator in BP, Harald Kulander, for providing information and guidance on several aspects.

SS&W Geomechanics Advisor in BP, Tron G. Kristiansen, for providing information and feedback.

Valhall & Hod Wells Team Leader, Marton Haga, for presenting different master thesis subjects and encouragement throughout the process.

I would also like to thank Wellbore AS for showing me around their workshop and explaining their casing / tubing opening tool.

Finally, I would like to thank the people in the department I've been sitting in, the Wells team, for encouragement, information and for making every day a bit better! It is a social and open environment that I have enjoyed participating in.

**Table of contents**

Abstract .....	2
Acknowledgements .....	4
Table of contents .....	5
List of Figures .....	8
List of Abbreviations .....	9
1 Introduction .....	12
1.1 Background .....	12
2 The Valhall Field [1] - [9] .....	14
2.1 Geology: .....	14
2.2 Production Strategy .....	16
2.3 Development .....	17
2.4 Completion strategy .....	18
2.5 Facilities .....	19
2.6 Future development .....	22
3 Theory .....	24
3.1 Permanent P&A - Laws, Regulations and Standards .....	24
3.1.1 The Petroleum Act [10] .....	24
3.1.2 The Petroleum Safety Authority (PSA) [11], [12] .....	24
3.1.3 NORSOK Standard D-010 – Well Integrity in Drilling and Well Operations [13] .....	27
3.1.4 BP Group Practice 10-60 – Zonal Isolation [14] .....	27
3.2 Well Barriers [13], [14] .....	28
3.2.1 Terms and Definitions .....	28
3.2.2 General Principles .....	29
3.2.3 Permanent Abandonment of wells .....	30
3.2.4 Comparison to Alaska Oil and Gas Conservation Commission (AOGCC) regulations, [32] .....	37
3.3 Compaction, Subsidence and Casing Deformations [24], [25] .....	39
3.3.1 Compaction and Subsidence in the Valhall field .....	39
3.3.2 Casing deformations .....	41
3.3.3 Tubular deformations and P&A .....	45
3.4 Traditional Technology .....	45
3.4.1 Section Milling [15] .....	45
3.4.2 Cut and Pull [27] .....	46
3.4.3 Multistring conductor and wellhead removal [13] .....	46
3.4.4 Control Line Removal [33] .....	47
3.5 New Technology .....	48
3.5.1 Reduce section milling time [17] .....	48
3.5.2 Hydrawell Intervention - Hydrawash [15] .....	49
3.5.3 Wellbore AS - Casing & Tubing Opening Tool [30] .....	51
3.5.4 NCA - Wellhead and Multistring Conductor Removal [22], [23] .....	51
Traditional Plugging Material .....	53
3.5.5 Cement [18] .....	53
3.6 New plugging materials .....	54
3.6.1 Sandaband [16] .....	54

- 3.6.2 CannSeal [19], [20]..... 56
- 3.6.3 ThermaSet [21], [18]..... 57
- 3.6.4 Verifying shale as an annulus barrier element [26], [18]..... 58
- 3.6.5 Settled Barite [36]..... 60
- 4 Potential sources of inflow [28], [39] ..... 61
- 5 Minimum depth for top of a secondary plug [40]..... 63
- 6 Well Categorization [39]..... 65
  - 6.1 Well Design ..... 65
    - 6.1.1 Wells with Annulus Cement ..... 65
    - 6.1.2 Wells without Annulus Cement ..... 66
    - 6.1.3 Wells with heavy wall liner overlap, with annular cement..... 67
    - 6.1.4 Wells with heavy wall liner overlap, without annular cement..... 67
    - 6.1.5 Well design summary on Valhall DP wells ..... 68
  - 6.2 Well Accessibility..... 69
    - 6.2.1 Full reservoir access..... 69
    - 6.2.2 Fill in tubing..... 69
    - 6.2.3 Partly collapsed well..... 69
    - 6.2.4 Fully collapsed well ..... 69
- 7 How to get through a collapsed section [39] ..... 70
  - 7.1 Casing/Tubing opening tool [30] ..... 70
  - 7.2 Abrasive technology ..... 70
  - 7.3 Extreme Expandacem [37]..... 71
  - 7.4 Milling [38]..... 71
  - 7.5 Sidetracking ..... 72
- 8 Generalized Operational Procedure [39] ..... 73
  - 8.1 Rig less work..... 74
    - 8.1.1 Well diagnostics..... 74
  - 8.2 Rigless / rig work ..... 75
    - 8.2.1 Kill well ..... 75
    - 8.2.2 Plug reservoir ..... 76
  - 8.3 Rig work..... 78
    - 8.3.1 Pull tubing..... 78
    - 8.3.2 Reservoir abandonment ..... 79
    - 8.3.3 Overburden Abandonment..... 80
    - 8.3.4 Set surface plug..... 82
  - 8.4 Rigless work..... 83
    - 8.4.1 Remove Multi string conductor ..... 83
    - 8.4.2 Platform removal [35], [39] ..... 84
- 9 Rig options [39] ..... 86
- 10 Discussion ..... 88
  - 10.1 P&A Regulations ..... 88
  - 10.2 Technical Challenges ..... 88
    - 10.2.1 Collapse challenges..... 89
    - 10.2.2 Well design challenges ..... 90
  - 10.3 Innovative Technology ..... 91
  - 10.4 Rig vs. Rig less ..... 92

10.5	Jack-up rig vs. Modular rig.....	93
10.6	P&A Campaigns .....	96
11	Conclusion and Recommendation .....	98
12	Reference .....	102
	Appendix A. Minimum depth to top of secondary reservoir plug for Valhall DP wells	106
	Appendix B. Well Construction on Valhall DP wells .....	107
	Appendix C. Operational procedure for Valhall DP well 2/8 - A - XX .....	110

## List of Figures

Figure 1: Location of the Valhall field. [7].....	14
Figure 2: TopHardChalk from 3Cmodel with LoFS cable grid overlay. [2].....	16
Figure 3: Platform placement on the Valhall field (Newly installed PH platform is missing). [Internal BP P&A presentation - Martin Straume] .....	18
Figure 4: The Valhall field center. [2] .....	21
Figure 5: West Epsilon drilling on Valhall Flank North. <a href="http://www.bp.com/genericarticle.do?categoryId=9003561&amp;contentId=7007431">http://www.bp.com/genericarticle.do?categoryId=9003561&amp;contentId=7007431</a> .....	22
Figure 6: The Government, The PSA and The NOROK.....	24
Figure 7: Cross sectional well barrier. [13] .....	31
Figure 8: Two HC - zones within the same pressure regime. [13] .....	32
Figure 9: Well Barrier Schematics of Permanent Plug and Abandonment. [13].....	34
Figure 10: The Valhall field center. [2] .....	40
Figure 11: Subsidence on the Valhall field. [2] .....	41
Figure 12: Casing deformation [K. Bashford - Abandonment in Greater Ekofisk], [24].	42
Figure 13: Localized casing deformation, [24].....	44
Figure 14: Milling tool [www.BakerHughes.com].....	46
Figure 15: Control lines. [18].....	47
Figure 16: Milling blade with trad. cutter. and Milling blade with P - cutter. [17].....	49
Figure 17: The Hydrawash tool - [www.hydrawell.no].....	50
Figure 18: CTO tool - two cones forced through a deformation. [29].....	51
Figure 19: Multistring conductor cut performed with abrasive water technology. [www.nca.com].....	52
Figure 20: Abrasive water cutting through steel. [www.nca.com] .....	52
Figure 21: Cement problems - [18].....	53
Figure 22: Sandaband in solid phase refloated to liquid phase. [Sandaband presentation from P&A forum 09.06.2011] .....	54
Figure 23: PP&A schematic on the 25/8-17 exploration well using Sandaband. [16] .....	55
Figure 24: Sandaband sump in collapsed well.....	56
Figure 25: The CannSeal technology - Injecting sealant. [www.agr.com/Our-Services/CannSeal/] .....	56
Figure 26: CannSeal as foundation for annular Sandaband plug.....	57
Figure 27: ThermaSet samples.....	58
Figure 28: Verifying shale as annulus well barrier .....	59
Figure 29: Zones that must be plugged at the crest of the Valhall field .....	62
Figure 30: Minimum depth to top of secondary reservoir plug with different fluid gradients.....	64
Figure 31: Reservoir well barriers in well with annular cement.....	66
Figure 32: Reservoir well barriers in well without annular cement.....	66
Figure 33: Reservoir well barriers in well with heavy walled liner overlap and annular cement. ....	67
Figure 34: Reservoir well barriers in well with heavy walled liner overlap, without annular cement. ....	68
Figure 35: Re-opening collapse with Casing/Tubing Opening tool. ....	70
Figure 36: Water melon mill and Taper mill. [38].....	71
Figure 37: Sidetracking to re-enter below collapse. ....	72



Figure 38: Typical Valhall DP production well with liner overlap and partially cemented annulus. ....	73
Figure 39: Well Diagnostics .....	74
Figure 40: Cement plugged reservoir. ....	77
Figure 41: Pulled tubing.....	78
Figure 42: Reservoir abandonment.....	79
Figure 43: Gas Cloud abandonment .....	81
Figure 44: Plugging of the potential sources of inflow in the overburden. ....	82
Figure 45: Completely P&A well. ....	83
Figure 46: Wellhead and multi string conductor removal. <a href="http://www.epmag.com/Production-Drilling/Decommissioning-Abandonment-Coordination-ensures-decommissioning-success_44547">http://www.epmag.com/Production-Drilling/Decommissioning-Abandonment-Coordination-ensures-decommissioning-success_44547</a> .....	84
Figure 47: Platform removal. [35] .....	85
Figure 48: Maersk reacher. <a href="http://www.ptil.no">www.ptil.no</a> King 500. <a href="http://www.kongshavn.no">www.kongshavn.no</a> .....	87
Figure 49: Pulling and Jacking unit placed on deck of damaged platform. [41] .....	93
Figure 50: Valhall production vs. number of drill strings. [Martin Straume].....	95
Figure 51: Well barrier schematic. 2/8 - A - XX [BP internal] .....	110

### List of Abbreviations

bbls - Barrels

bbls/d - Barrels per day

BHA - Bottom Hole Assembly

Boe - Barrels of oil equivalents

BOP - Blow Out Preventer

Bw - Barrels of water

CTO - Casing and Tubing Opening

CT - Coiled Tubing

DP - Drilling Platform

DPZ - Distinct Permeable Zone

GP - Group Practice

HSE - Health, Safety and Environment

IP - Injection Platform

LCM - Lost Circulation Material

LoFS - Life of Field Seismic

LOT - Leak Of Test

LWI - Light Well Intervention

M - Thousand

MM - Million

MD - Measured Depth

NCA - Norse Cutting and Abandonment

NCS - Norwegian Continental Shelf

NNW - North NorthWest

NORSOK - Norsk Sokkels Konkurransesposisjon

NPD - Norwegian Petroleum Directorate

OD - Outer Diameter

OLF - Oljeindustriens Landsforening

P&A - Plug and Abandon

PACE - Production Advanced Collaboration Environment

PBR - Polished Bore Receptacle

PCP - Process and Compression Platform

PDO - Plan for Development and Operation

PH - Production and Hotel platform

PSA - Petroleum Safety Authority

QP - Quarter Platform

RKB - Rotary Kelly Bushing

RPM - Revolutions Per Minute

SBT - Segmented Bond Tool

scf - Standard cubic feet

scm - Standard Cubic Meters

SSE - South SouthEast

TBL - Teknologibedriftenes Landsforening

TOC - Top Of Cement

TVD - True Vertical Depth

VFD - Valhall Flank Development

WBE - Well Barrier Element

WBM - Water Based Mud

WL - Wire Line

WP - Wellhead Platform

XMT - Christmas Tree

## **1 Introduction**

This thesis examines how to plug and abandon (P&A) the Valhall DP wells. Valhall is a BP operated oil field in the southern part of the Norwegian sector of the North Sea. The oldest drilling platform (DP) and wells are 30 years old, and integrity issues require P&A to be performed. The following thesis describes the field, the P&A regulations, innovative technology, the technical challenges and how P&A can be done.

### **1.1 Background**

There are a lot of challenges abandoning these wells. As of today 10 out of 30 wells are still active and counts for about 30% of the production from the Valhall field. The weak chalk reservoir at about 2450 mTVD RKB has undergone severe depletion which has led to compaction of more than 10 meters in the crest. The compaction has led to severe tubular deformation in many of the wells. These deformations make it difficult in some cases to reach the necessary plugging depth. The challenging overburden and well conditions on Valhall have led to a continuous development of well design where plug and abandonment had less focus than production. This makes several of the wells very challenging to P&A.

In the overburden of the Valhall field there are several zones that are potential sources of inflow. The flow potential and plugging requirements for each zone has been analyzed.

P&A is an area that is receiving more and more attention from innovative technology companies due to the large potential in value adding cost efficiency for the oil companies and thereby revenues for the service companies. A review of new technology that have potential of being cost efficient for the plugging of the Valhall DP wells is added in this thesis.

The high oil price brings challenges towards hiring a suitable rig for P&A. BP Norway has the jack-up Maersk Reacher on a long term contract. This rig is very expensive and mostly intended for drilling production wells. A less expensive rig type is a modular rig which could be placed on the Valhall DP platform to perform P&A instead of the jack-up. This solution has therefore also been analyzed. There is also cost reduction potential

in doing as much work as possible with coil tubing / wire line in campaigns before the rig arrives. This allows the rig to focus on drilling activities in stead.

## 2 The Valhall Field [1] - [9]

The Valhall area is located in blocks 2/8 and 2/11 about 290km south of Stavanger as seen in figure 1. The Valhall area is comprised of the Valhall field with the north and south flank and the Hod oilfield. The water depth in the area is about 70m.



**Figure 1: Location of the Valhall field. [7]**

The Valhall field is owned by BP Norge A/S (35, 95%) and Hess Norge A/S (64, 05%), but operated by BP. The field was discovered in 1975, approved for development in 1977 and had first production in 1982. When the plan for development and operation (PDO) of the Valhall field was approved the initial volume estimates were around 250MMbbls. To this date more than twice of this amount has been produced and there is work ongoing to recover more than 1 billion bbls from the Valhall structure. The reserves have increased due to:

- Better reservoir description
- Improved drilling and completion strategy
- Development of the flanks and water flooding of the crestal area
- Reservoir compaction as a drive mechanism

### **2.1 Geology:**

The structure of the Valhall field is an asymmetric anticline, trending NNW – SSE covering about 80km<sup>2</sup>. The crest is covering about 30km<sup>2</sup> and the flanks are covering the remaining 50km<sup>2</sup>. The inversion structure formed due to trans-tension that began in the

Turonian followed by some quiet periods and more inversion that finally ended in the Miocene.

The reservoir depth is ca 2450m TVD RKB and the main reservoir is within the Tor formation that is divided into four reservoir zones. The secondary reservoir is in the Hod formation that is divided into six reservoir zones. The two formations are separated by a low porosity hard ground. The thickness of the Tor formation varies from 0 - 80m, while the thickness of the best Hod formation, H4, is in the range of 20-30m. The reservoir properties vary quite a bit with the best porosities up to 50% and matrix permeability in the range of 1-10mD found in the thickest areas which are at the crest. Initial well test data indicated effective permeability 3-15 times matrix permeability caused by fracture permeability. Due to strong depletion most of this has now been reduced to matrix permeability. Water saturation is fairly low and in the range 3 -8%. In general, Tor has the best reservoir properties and contains between 65 – 75% of the hydrocarbons. In the thinner areas, the Tor formation is generally a high porosity chalk layer on top of a hard ground with abrupt changes in the lateral direction which makes it difficult to drill horizontal wells.

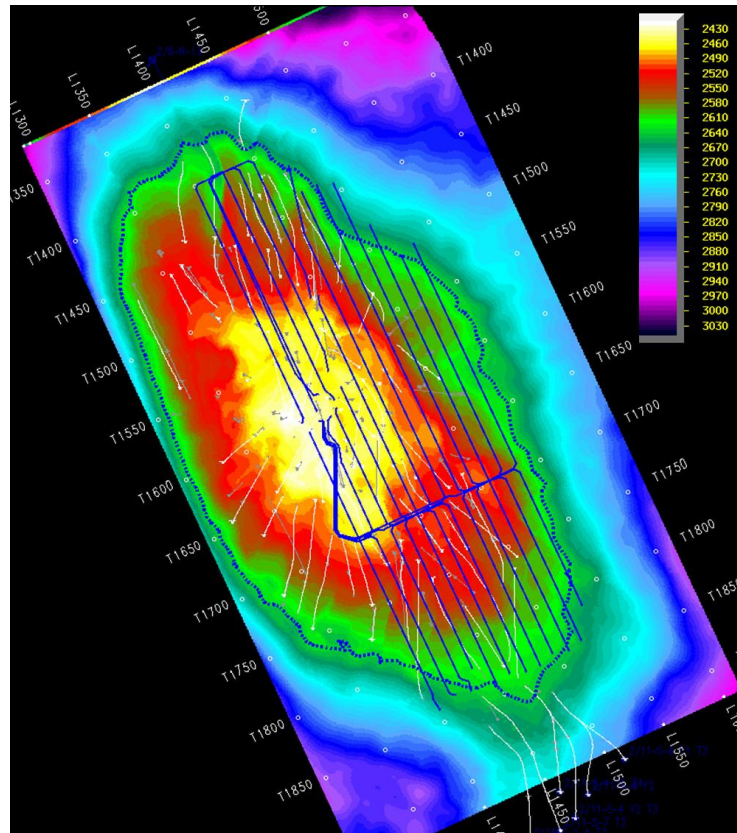

**Figure 2: TopHardChalk from 3Cmodel with LoFS cable grid overlay. [2]**

The source for the oil in the Valhall field is the Kimmeridge clay that is from the Upper Jurassic Mandal formation. The oil generation started in early Miocene and is still ongoing. The seal of the Valhall field is a 1000m thick claystone section. In this claystone, there exist microfractures created by overpressure in the chalk. Oil and gas has migrated upwards through these fractures and created a large gas cloud in the Miocene section at about 1350m TVD RKB overlying the crest. This gas cloud is calculated to contain about 500mmbbl oil equivalents and causes major challenges to the seismic interpretation of the Tor reservoir. Life of Field Seismic (LoFS) was installed in 2003 and covers 70% of the field as shown in figure 2. The LoFS has improved the interpretation of the subsurface and contributed to making better decision within well planning, well management and in the reservoir teams.

## **2.2 Production Strategy**

The Valhall field has been produced through primary depletion since 1982 with a virgin pressure of 6500psi. An additional drive mechanism has been rock compaction. This has



been possible due to the unconsolidated high porosity chalk. In 2004, this actually provided more than 50% of the reservoir energy. Since 1988 the reservoir pressure in the Tor formation has been below the bubble point which is around 3500psi. In January 2004 water injection was initiated to maintain the pressure in the reservoir and in that way increase the recoverable reserves. It is calculated that water flooding on Valhall holds resources in excess of 130mmbow with injection of 700mmbw over the remaining life of the field, excluding potential on the West Flank. There is also a value in avoiding drilling problems when drilling into a less depleted reservoir. The rate of the injected water has been stable, but there have been some problems due to rapid water breakthrough in offset producing wells. When injected sea water breaks into a producing well, it causes major concerns towards scale problems. However, the positive effect of pressure support has been verified by pressure gauges in several wells in the crestal area.

### ***2.3 Development***

Initial testing at Valhall proved that chalk production and casing deformation could be a serious problem. When the decision to go forward with the development of Valhall was taken, it was considered crucial to control solids production without hindering the production of oil. Drilling long reach wells has been a real challenge on Valhall due to the subsidence. Trying to reach the flanks from the centre of the field has several times proven to be extremely difficult. Therefore, the VFD (Valhall Flank Development) was initiated in the north and the south to better extract volumes not possible to reach from the centre. The overview of the Valhall field can be seen in figure 3.

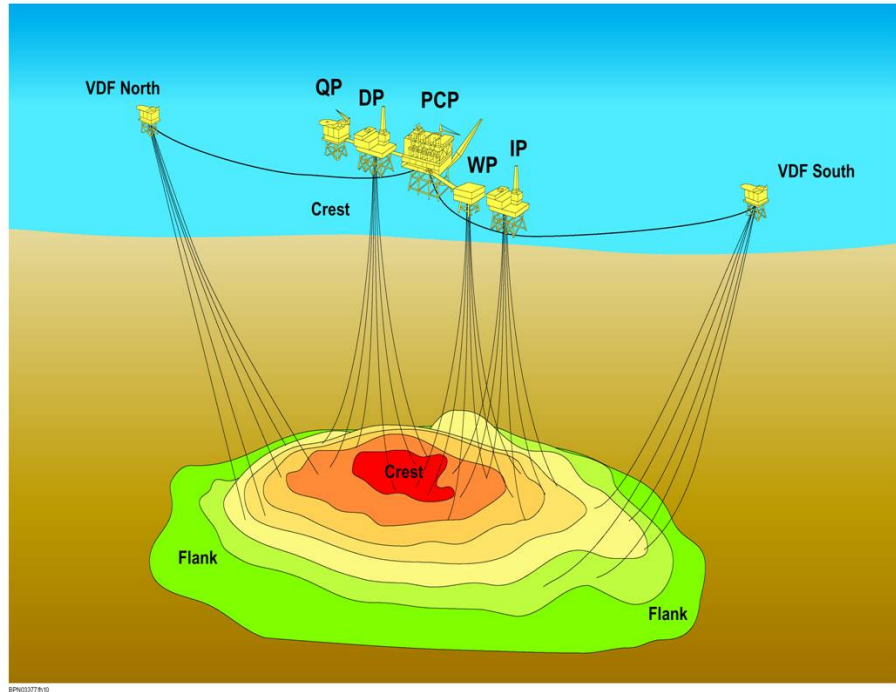

**Figure 3: Platform placement on the Valhall field (Newly installed PH platform is missing). [Internal BP P&A presentation - Martin Straume]**

Only wells with less than 60 degrees inclination should be drilled from the centre due to increased hole instability at higher angles. Oil is transported to the 2/4 J pumping platform at Ekofisk before it is pumped to Teesside in England. The gas is routed directly into the pipeline going to Emden in Germany.

## **2.4 Completion strategy**

Due to the weak chalk reservoir, it was early recognized that the completion design would be a critical factor to successfully produce the field. There has been a continuous development of completion strategy since day one. The focus has been put on limiting solids production and well failures.

The first completion strategy was called “Up and under fracturing”. The idea was to perforate the more competent upper Hod formation below the weaker Tor formation and perform propped fracture stimulation up into the high porosity chalk. For some years this was a success until massive chalk production and well collapses in the mid-1985 resulted in a drop in production from around 60mmbbls/d to 30mmbbls/d.

From 1985-1990 a new method called “Propped fractured gravel packs” was used on most of the wells. The wells were now propped fractured directly into the Tor chalk, and a gravel pack was designed to support the weak chalk. This was successful in reducing chalk production and well failures until new solids production problems started to materialize from 1990. This happened due to high pressure differential across the gravel packs.

From 1990-1995, reservoir studies had shown that horizontal wells would enable increased recovery and higher flow rates at lower drawdowns. The first horizontal well was drilled in 1990/1991. Later it proved that the theoretical performance of the horizontal wells had been too optimistic considering that the Tor chalk is very stress sensitive. A dramatic increase in well failures was seen. In the horizontal section one typically lost access to about 80% during the first six months of production due to chalk production and collapsed liners.

From 1995 a new concept was developed. This concept was a horizontal cased hole completion with multiple propped fractures. To increase hole stability and strength, heavy wall liners and 180 degree perforation phasing was implemented. To this day the concept is quite similar; the difference is mostly regarding shorter fractures and more fractures due to extracting thinner reservoir sections.

## **2.5 Facilities**

In the PDO from 1977, Valhall was originally planned with three platforms: The Quarter Platform (QP), the Drilling Platform (DP) and the Process and Compression Platform (PCP). Over the years, compaction of the chalk has led to over 6m of seabed subsidence. Therefore, the original platforms don't fulfill the security demands with regard to wave height. These platforms are, however, still running on exemption that says that they must be de-manned if extreme weather is forecasted. These original platforms will have to be decommissioned before the end of the lifetime of the field.

The QP has been the living quarter since 1981. The recent years a number of cabins have been converted to single occupancy. The capacity is 208 people. This platform will be

taken out of use when the new Production & Hotel (PH) platform is properly up and running.

The PCP is designed to produce 168mbbls/d of oil and 10mmscm/d of gas. The PCP also receives oil and gas from Hod and returns gas to the latter field for gas lift. During 2012 the production on Valhall and Hod will be routed to the new PH platform. The PCP will be prepared for removal, but will be there for as long as there is activity on DP because of the new bridge connection.

The DP platform has 30 well slots. One of the well slots holds a splitter well, so there are a total of 31 wells on DP. In the PDO for Valhall redevelopment from 2007, DP is scheduled for P&A in 2014. The estimated time to P&A all 31 wells on Valhall DP is about 5 years, depending on the methodology chosen.

In 1996 the Wellhead Platform (WP) was installed providing 19 extra slots.

In 2003 the Injection Platform (IP) was installed. IP contains equipment for waterflood, injection pumps for water injection and a drilling module that can be skidded over to WP also. Valhall IP has 24 well slots, both for production and injection wells. Valhall IP is connected to onshore with fiber optics. This enables live offshore data in town so that better, safer and quicker decisions may be taken.

The installation of the new PH platform was completed in March 2011, the field center as it looks like now is shown in figure 4. During the summer of 2011, electric power from land was accomplished and during 2012 all the production from PCP will be routed to PH. The capacity on PH is 120mbbl/d of oil and 143mmscf/d of gas. It is built to last for 40 years and has bed capacity for 180 people. With this new platform, the entire Valhall field gets electric power from land. This has contributed to a 97% CO<sub>2</sub> reduction and 90% NO<sub>x</sub> reduction on Valhall.



**Figure 4: The Valhall field center. [2]**

Valhall Flank North and South are two identical platforms that were installed in 2003 and 2004 with 16 well slots on each. They are localized 6km north and south of the Valhall field centre as shown in figure 3. and figure 5. Equipment for gas lift and water injection was made on both platforms. Due to the position of these platforms, the wells drilled towards the field centre gets a J-shaped well trajectory. This creates well liquid loading effects (water locks). These wells have been challenging with regard to optimizing production since there is quite low reservoir pressure and high back pressure on the platforms. To deal with this challenge, drag reducing agents has been injected. These have lowered the pressure in the flow lines with about 50 psi. To minimize slugging, there has been installed choke controllers on some of the wells.



**Figure 5: West Epsilon drilling on Valhall Flank North.**

<http://www.bp.com/genericarticle.do?categoryId=9003561&contentId=7007431>

In February 2009, the new Valhall Production Advanced Collaboration Environment (PACE) opened in BP-gården at Forus. This center brings onshore and offshore closer together and has advantages concerning: Optimization of production, planning, daily logistics and operational support.

A new production control center has also been installed onshore at Forus. All the wells on Valhall can now be controlled and supervised both from offshore and onshore. With this center, it is possible for several experts to look at live data and make optimal decisions.

## ***2.6 Future development***

Recently, a new project called “The Greater Valhall Program” has been approved to go forward, even with a lot of work still remaining before a field development decision can be made. This project includes a new platform on Hod, followed by expansion of the Life of Field Seismic and a new flank platform west of the Valhall center. There will also be

some smaller projects concerning produced water and gas treatment. All in all, the project is looking at investments of more than NOK 25 billions to take Valhall forward to 2050.

### 3 Theory

#### 3.1 Permanent P&A - Laws, Regulations and Standards

The need for decommissioning is given by law in the Petroleum Act and regulated by the Petroleum Safety Authority (PSA) which again refers to the NORSOK (Norsk Søkkel Konkurransesisjon) standards that are developed by interested parties in the Norwegian petroleum industry. The NORSOK standards are the oil industry's own document and not an authority document. The NORSOK standards are guidelines that help companies, operating on the Norwegian continental shelf, to operate safely and cost effective. These guidelines may be omitted if an equally good or better solution is proposed.



Figure 6: The Government, The PSA and The NORSOK

##### 3.1.1 The Petroleum Act [10]

In Act 29 November 1996 No. 72 relating to petroleum activities section 5-1 it is stated: *“The licensee shall submit a decommissioning plan to the Ministry... The plan shall contain proposals for continued production or shutdown of production and disposal of facilities. Such disposal may inter alia constitute further use in the petroleum activities, other uses, complete or part removal or abandonment.”*

##### 3.1.2 The Petroleum Safety Authority (PSA) [11], [12]

The 1. of January 2004, the Petroleum Safety Authority was formed as an independent governmental regulator. The PSA is subordinate to the Ministry of Labour and is the regulator for technical and operational safety, including emergency preparedness, and for the working environment in all phases of the petroleum activity - such as planning, design, construction, use and possible later removal. Before 2004 the Norwegian Petroleum Directorate (NPD) had this responsibility.



Regulations that is normative for Permanent P&A:

To get a better understanding of the regulations there are some terms that must be defined:

- Should: *“verbal form used to indicate that among several possibilities one is recommended as particularly suitable, without mentioning or excluding others, or that a certain course of action is preferred but not necessarily required.”*
- Shall: *“verbal form used to indicate requirements strictly to be followed in order to conform to the standard and from which no deviation is permitted, unless accepted by all involved parties.”*

Regulations relating to design and outfitting of facilities, etc. in the petroleum activities are gathered in the Facility Regulations

These regulations apply to offshore petroleum activities, with exceptions as mentioned in Section 4 of the Framework Regulations.

The Facilities Regulations - Section 48:” *Well Barriers*

- *Well barriers shall be designed such that well integrity is ensured and the barrier functions are safeguarded during the well's lifetime.*
- *Well barriers shall be designed such that unintended well influx and outflow to the external environment is prevented, and such that they do not hinder well activities.*
- *When a well is temporarily or permanently abandoned, the barriers shall be designed such that they take into account well integrity for the longest period of time the well is expected to be abandoned.*
- *When plugging wells, it shall be possible to cut the casings without harming the surroundings.*
- *The well barriers shall be designed such that their performance can be verified.”*

In the guidelines to these regulations it is written: *“In order to fulfill the requirement to well barriers, the NORSOK D-010 standard revision 3 Chapters 4.2.1, 4.2.3, 5.6, 9 and 15 should be used in the area of health, working environment and safety.”*

Regulations relating to conducting petroleum activities are gathered in the Activities Regulations.

These regulations apply to offshore petroleum activities, with exceptions as mentioned in Section 4 of the Framework Regulations.

The Activities Regulations – section 88: *“Securing wells*

- *All wells shall be secured before they are abandoned so that well integrity is safeguarded during the time they are abandoned, cf. Section 48 of the Facilities Regulations.*
- *Abandonment of radioactive sources in the well shall not be planned. If the radioactive source cannot be removed, it shall be abandoned in a prudent manner.”*

For permanent abandonment this means that well integrity shall be maintained with an eternal perspective. This is of course not possible to verify, but one shall strive to construct barriers that can withstand possible future conditions.

In the guidelines to the Activities Regulations – section 88 Securing Wells it is written:”

- *If it is necessary to abandon the radioactive source in the well, as mentioned in the third subsection, the NORSOK D-010 standard, Chapter 9 and table 15.24 should be used, with the following additions:*
  - *an internal overview of abandoned sources should be established and maintained. The overview should contain details about every single source and its position,*
  - *radioactive sources abandoned in work strings should be secured in a manner which clearly indicates any unintentional drilling close to/in the direction of the source’s position.”*

### **3.1.3 Norsok Standard D-010 – Well Integrity in Drilling and Well Operations [13]**

In the foreword of Norsok D-010 Rev. 3, August 2004 it is written: “...*NORSOK standards are as far as possible intended to replace oil company specifications and serve as reference in the authorities’ regulations.*” The Norsok standard is developed with broad petroleum industry participation by interested parties in the Norwegian petroleum industry and is owned by the Norwegian Oil Industry Association (Oljeindustriens Landsforening - OLF) and Federation of Norwegian Manufacturing Industries (Teknologibedriftenes landsforening - TBL). Standards Norway is responsible for the administration and publication of the Norsok standard.

The Norsok standards are developed to ensure adequate safety, value adding and cost effectiveness for petroleum industry developments and operations. The Norsok D – 010 standard is based on recognized international standards from ISO, API, ASTM, Norsok and OLF, added the provisions deemed necessary to fill the broad needs for the Norwegian petroleum industry. At the time this thesis is written, revision 4. is under construction and will probably be launched during the autumn 2012.

### **3.1.4 BP Group Practice 10-60 – Zonal Isolation [14]**

The scope of this group practice is to provide company requirements, unity on global basis and recommendations to ensure that WBEs are installed to achieve zonal isolation during:

- Well Construction

- Temporary Abandonment

- Permanent Abandonment

GP 10-60 is based on several internationally recognized standards from API, BOEMRE, Norsok, and UKOOA in addition to various BP standards.

If the group practice conflicts with relevant laws or regulations in the individual country, the relevant laws or regulations shall be followed. If, however, GP 10-60 creates a higher obligation, it shall be followed as long as this also achieves full compliance with the laws or regulations.

### **3.2 Well Barriers [13], [14]**

As mentioned earlier the PSA refers to the Norsok D-010 standard when well barriers are constructed. At the same time BP has its own practice, the GP 10-60 to consider.

If there is a conflict between the BP standard and the Norsok standard, the Norsok standard shall be followed. If the BP standard creates a higher obligation, it shall be followed as long as this also achieves full compliance with the Norsok standard.

The Norsok D-010 and GP 10-60 standards have been compared and the minimum requirements to fulfill both standards have been listed below. Many of the sentences below are directly quoted from both standards.

#### **3.2.1 Terms and Definitions**

*Well Integrity: Application of technical, operational and organizational solutions to reduce risk of uncontrolled release of formation fluids throughout the life cycle of a well.*

*Well Barrier Element – WBE: Object that alone can not prevent flow from one side to the other side of it self.*

*Well Barrier: Envelope of one or several dependent barrier elements preventing liquids or gases from flowing unintentionally from one formation, into another formation or to surface.*

*Primary Well Barrier: First object that prevents flow from a source.*

*Secondary Well Barrier: Second object that prevents flow from a source.*

*Permanent Well Barrier: Well barrier consisting of WBEs that individually or in combination creates a seal that has a permanent/eternal characteristic.*

*Permanent Abandonment: Well status, where the well or part of the well, will be plugged and abandoned permanently, and with the intention of never being used or re-entered again.*

Common Well Barrier Element: *Barrier element that is shared between the primary and secondary well barrier.*

Permeable zone (GP 10-60): *Zone with sufficient permeability such that a credible pressure differential would result in the movement of fluids (oil, water, or gas) and/or development of sustained casing pressure (Read as “potential source of inflow” in NORSOK).*

Distinct Permeable Zone (DPZ) (GP 10-60): *Permeable zone or group of permeable zones in which intrazonal isolation is not required for operation or abandonment of the well (Read as “Reservoir” in NORSOK).*

### **3.2.2 General Principles**

Well barrier acceptance criteria are technical and operational requirements that must be fulfilled to qualify the well barrier or WBE for its intended use.

If there is a pressure differential that may cause uncontrolled cross flow between formations there shall be one well barrier in place during all well activities and operations, including suspended and abandoned wells.

If there is a pressure differential that may cause uncontrolled flow from the well to the external environment there shall be two well barriers in place during all well activities and operations, including suspended and abandoned wells

For a well barrier to be accepted it shall be designed, selected and/or constructed such that

- it can withstand the maximum anticipated differential pressure it may become exposed to.
- it can be leak tested and function tested or verified by other methods.

- no single failure of well barrier or WBE leads to uncontrolled outflow from the borehole / well to the external environment.
- re-establishment of a lost well barrier or another alternative well barrier can be done.
- it can operate competently and withstand the environment for which it may be exposed to over time.

For permanent abandonment, which means for eternity, it is of course not possible to verify that the well barrier actually withstands the environment for the eternity. Especially when considering extreme events like large earthquakes. Anyhow risk shall be reduced as low as reasonable practicable.

The primary and secondary well barriers shall to the extent possible be independent of each other without common WBEs. If common WBEs exist, a risk analysis shall be performed and risk mitigation/reducing measures applied to reduce risk as low as reasonable practicable.

When a permanent abandonment well barrier has been constructed, its integrity and function shall be verified by means of

- leak testing by application of differential pressure.
- verification by other specified methods (i.e. weight tested, volumetric..).

### **3.2.3 Permanent Abandonment of wells**

Permanently plugged wells shall be abandoned with an eternal perspective, i.e. for the purpose of evaluating the effect on the well barriers installed after any foreseeable chemical and geological process has taken place. Distinct permeable zones (DPZs) previously identified shall be reviewed for isolation requirements for permanent abandonment. New DPZs that are identified at the time of well abandonment shall be isolated with the same requirements as already known DPZ.

For wells to be permanently abandoned, with several sources of inflow, the usual; one primary and one secondary well barrier, do not suffice. There shall be at least one well

barrier between surface and a potential source of inflow, unless it is a reservoir (contains hydrocarbons and/ or has a flow potential) where two well barriers are required. The functions of a well barrier and a plug can be combined except a secondary well barrier can never be a primary well barrier for the same reservoir. A secondary well barrier for one reservoir formation may act as a primary well barrier for a shallower formation, if this well barrier is designed to meet the requirements of both formations.

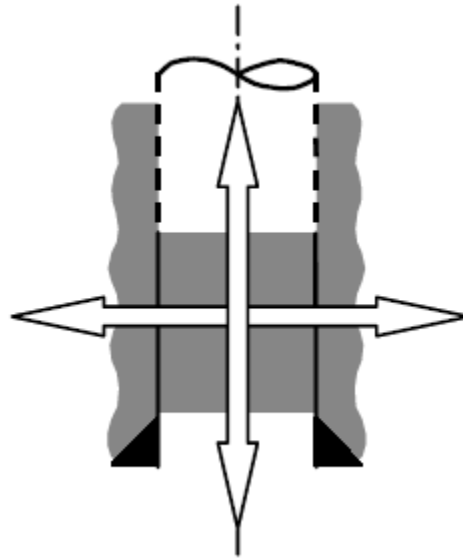

**Figure 7: Cross sectional well barrier. [13]**

Well barriers should be installed as close to the potential source of inflow as possible, covering all possible leak paths. The primary and secondary well barriers shall be positioned at a depth where the estimated formation fracture pressure at the base of the plug is in excess of the potential internal pressure. The final position of the well barrier/WBEs shall be verified.

The last open hole section of a wellbore shall have a permanent well barrier, regardless of pressure or flow potential. The complete wellbore shall be isolated.

Permanent well barriers shall extend across the full cross section of the well, include all annuli and seal both vertically and horizontally as shown in figure 7. Therefore a WBE set inside a casing as a part of a permanent well barrier shall be located where there is a

WBE with verified quality in all annuli. A permanent well barrier should have the following properties:

- Impermeable
- Long term integrity
- Non shrinking
- Ductile
- Resistance to different chemical/ substances
- Wetting

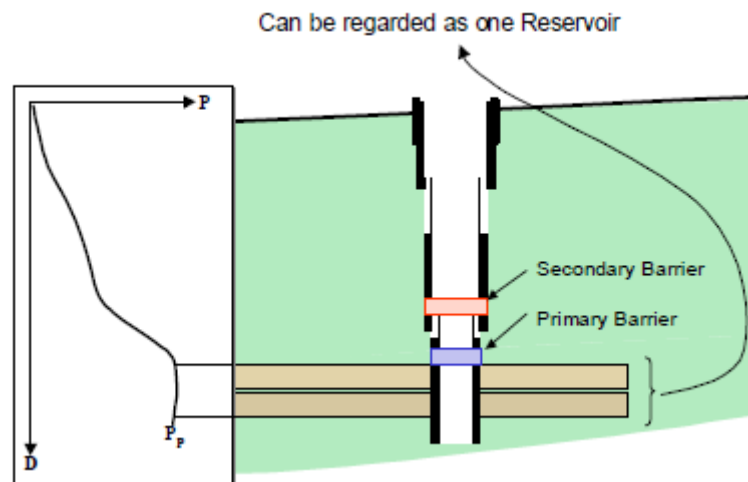

Figure 8: Two HC - zones within the same pressure regime. [13]

The most common WBE in permanent abandonment is cement; both casing cement and cement plug in the wellbore. It may be discussed how well cement conforms to the properties listed above:

Non shrinking - Cement shrinks as it settles creating cracks that makes it a bit permeable.

→ New type of cement with expanding material is becoming more and more usual.

Ductile - Cement has a more brittle behavior. → Projects are ongoing to add materials that give a more ductile behavior to cement.

Open hole cement plugs can be used as a well barrier between reservoirs as long as the WBE isolating the wellbore in the reservoirs second well barrier is inside the casing. It should, as far as practicably possible, also be used as a primary well barrier.



Removal of downhole equipment is not required as long as the integrity of the well barriers is achieved. Control cables and lines shall be removed from areas where permanent well barriers are installed.

Multiple reservoir zones located in the same pressure regime, isolated with a well barrier in between, can be regarded as one reservoir where a primary and secondary well barrier shall be installed as shown in figure 8.

Primary and secondary well barriers may be combined, if all of the following conditions are met:

- A common WBE of annulus cement is established.
- A secondary well barrier can never be a primary well barrier for the same reservoir.
- A common WBE cement plug is established in the wellbore extending above a potential source of inflow a minimum height of:
  - 60 m TVD if proven by weight testing
  - 300 m TVD if mechanically tagged for through tubing abandonment
  - 800 m MD

A single continuous cement plug across multiple DPZs may be used as permanent abandonment WBEs isolating the wellbore for each DPZ if all of the following requirements are met:

- Annulus cement for each DPZ is established (i.e. SBT)
- Cement plug is placed on a tagged and pressure tested base (i.e. mechanical plug)
- The cement plug is verified (i.e. weight tested, leak tested..)

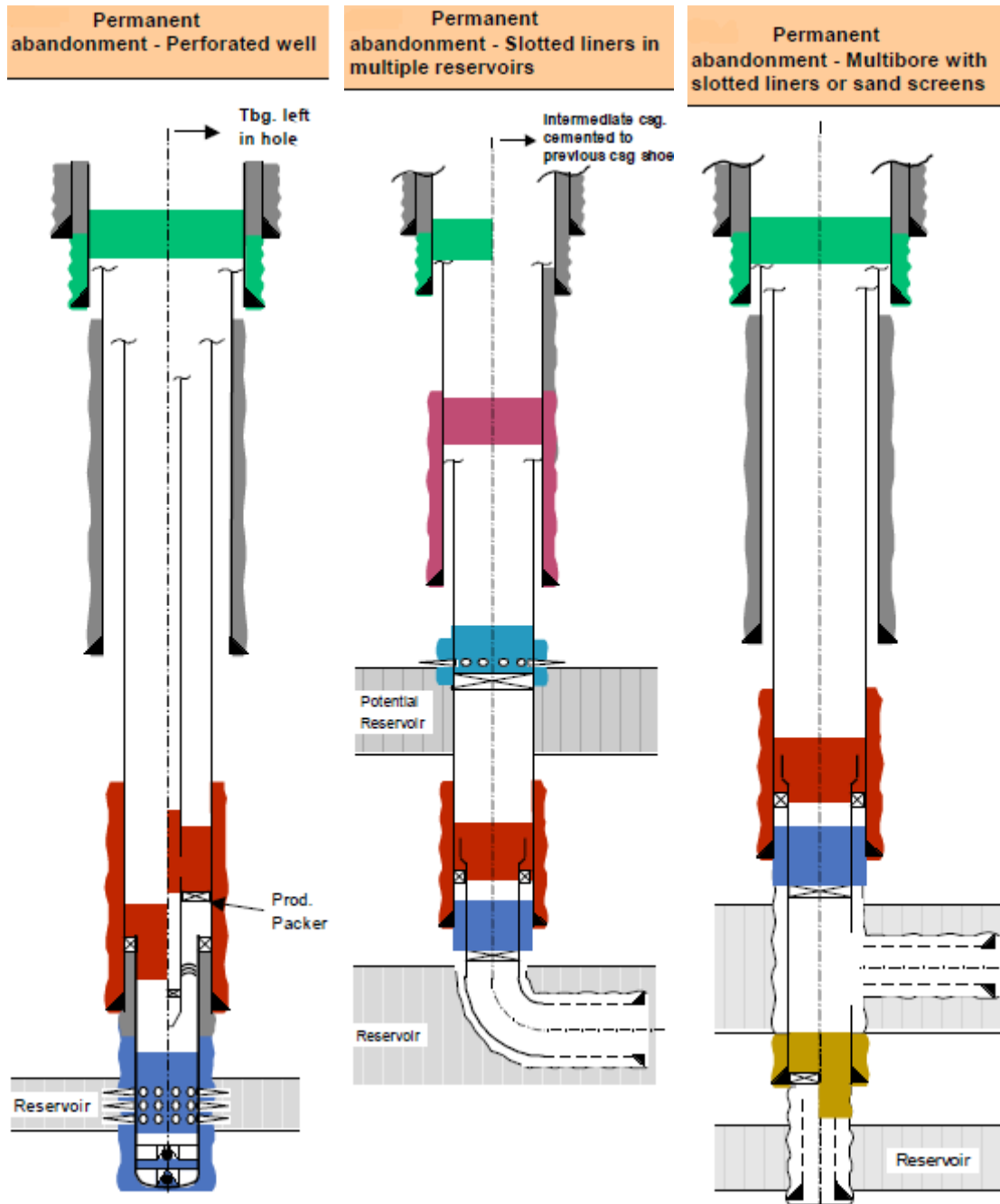

Figure 9: Well Barrier Schematics of Permanent Plug and Abandonment. [13]

WBEs isolating the annulus and wellbore shall be constructed of cement unless an alternative material is qualified in accordance with:

A risk assessment considering as a minimum:

- Temperature
- Pressure differential
- Fluids

- Relevant testing

Alternative material shall exhibit the following properties:

- Permeability less than 0,1mD
- Mechanical stability with eternal time perspective at down hole conditions
- Strength and/or ductility to accommodate mechanical loads or formation movements

BP region wells organization shall define and execute a qualification plan based on the risk assessment.

Alternative material shall be subject to BP approval.

The purpose of the annulus cement is to provide a continuous, permanent and impermeable hydraulic seal in the casing annulus to prevent flow of formation fluids, resist pressure migration and support casing or liner strings structurally. The properties of the set cement shall be capable to provide lasting zonal isolation and structural support. Annulus cement shall be an acceptable permanent abandonment WBE for wells with no evidence of Sustained Casing Pressure, if the following requirements are met:

Record shall exist from the time of annulus cement installation and verified with one of the following requirements:

- Circumferential logging:
  - Minimum compressive strength = 200 psi
  - TOC = 200mMD and TOC = 30mTVD above shallowest point of leakage or next casing. shoe.
  - TOC = 30mTVD or the complete interval between DPZs, if more than one in same cemented interval.
  - Measured hydraulic seal = 30mTVD
- TOC:
  - Minimum compressive strength = 200 psi
  - TOC = 200mTVD above shallowest point of leakage or next csg. shoe.
  - TOC > 100mTVD or the complete interval between DPZs, if more than one in same cemented interval.

- Measured hydraulic seal - Not Available
- Cement job requirements for acceptance of verification technique  
→ see GP 10-60 Table 2 Column B which contains specific requirements and verification criteria for TOC.
- Alternative method:
  - Method shall be documented and include evidence demonstrating suitability.
  - Method shall be confirmed periodically using circumferential logs.

Records shall also contain location of the annulus cement in the well

Annular shale may be accepted as an annular well barrier if no communication is measured with a communication test that conforms to the following requirements:

- Annulus of the well is perforated with two sets of perforations and a packer set between the perforations.
- Perforations are LESS than 30 m apart.
- Communication test is initiated in LOT mode.

The purpose of a cement plug is to prevent flow of formation fluids inside a wellbore between formations and/or to surface. The properties of the cement plug shall be capable to provide lasting zonal isolation. Permanent cement plugs should be designed to provide a lasting seal with the expected static and dynamic conditions and loads down hole. It shall be designed for the highest pressure differentials and temperature expected inclusive installation and test loads. Cement plugs shall be constructed to the following requirements:

- Cement shall have a compressive strength of 200 psi, as confirmed by laboratory testing of rig samples prior to the initiation of verification testing.
- Cement plugs shall be both weight tested and positive pressure tested unless criteria found in GP 10-60 10.4.2.2 “*circumstances in which weight or pressure testing may be omitted*” are met.
- The firm plug length shall be 100 m MD.
- If a plug is set inside casing and with a mechanical plug as a foundation, the minimum length shall be 50 m MD.

- It shall extend minimum 50 m MD and 30 m TVD above any source of inflow.
- A plug in transition from open hole to casing should extend at least 50 m MD below casing shoe.
- A casing/ liner with shoe installed in permeable formations should have a 25 m MD shoe track plug.

When permanently abandoning wells, the wellhead and following casings shall be removed so that no parts are above the seabed. The cutting depth should be around 5 meters below the seabed.

### **3.2.4 Comparison to Alaska Oil and Gas Conservation Commission (AOGCC) regulations, [32]**

A short comparison to the regulations in Alaska has been made to get an overview of the differences that may exist between regulations from different mature oil and gas regions. The relevant regulations for this thesis are found in AOGCC regulations, title 20, chapter 25, section 1. Drilling and section 2. Abandonment and Plugging.

In section 1. Drilling - Casing and Cementing it is stated that:

*“(1) ...a well casing and cementing program must be designed to:*

*(1.1) confine fluids to the wellbore;*

*(1.2) prevent migration of fluids from one stratum to another;*

*(1.3) protect significant hydrocarbon zones;*

*(2)...Specific well casing cementing provisions are as follows:*

*(2.1) intermediate and production casing must be cemented with sufficient cement to fill the annular space from the casing shoe to a minimum of 500 feet above all significant hydrocarbon zones and abnormally geo-pressured strata. If indications of improper cementing exist, such as lost returns, or if the formation integrity test shows an inadequate cement job, remedial action must be taken.”*

In section 2. Abandonment and Plugging - Well plugging requirements it is stated that:  
*“(1) Plugging of the uncased portion of a wellbore must be performed in a manner that ensures that all hydrocarbons and freshwater are confined to their respective indigenous strata and are prevented from migrating into other strata or to the surface. The minimum requirements for plugging the uncased portion of a wellbore are as follows:*

*(1.1) by the displacement method, a cement plug must be placed*

*(1.1.1) from 100 feet below the base or the well’s total depth to 100 feet above the top of all hydrocarbon-bearing strata;*

*(1.1.2) from 100 feet below the base to 50 feet above the base of each significant hydrocarbon-bearing stratum and from 50 feet below the top to 100 feet above the top of each significant hydrocarbon-bearing stratum;*

*(1.2) by the displacement method, a cement plug must be placed from 100 feet below the base to 50 feet above the base of each abnormally geo-pressured stratum and from 50 feet below the top to 100 feet above the top of each abnormally geo-pressured stratum;*

*(1.3) by the displacement method, a cement plug must be placed from 150 feet below the base to 50 feet above the base of the deepest freshwater stratum.*

*(2) Plugging of a well must include effectively segregating uncased and cased portions of the wellbore to prevent vertical movement of fluid within the wellbore. The minimum requirement for plugging to segregate uncased and cased portions:*

*(2.1) by the displacement method, a continuous cement plug must be placed from 100 feet below to 100 feet above the casing shoe;*

*(3) Plugging of cased portions of a wellbore must be performed in a manner that ensures that all hydrocarbons and freshwater are confined to their respective indigenous strata and are prevented from migrating into other strata or to the surface. The minimum requirements for plugging cased portions of a wellbore are as follows:*

*(3.1) perforated intervals must be plugged:*

*(3.1.1) by the displacement method, a cement plug placed from 100 feet below the base or from the wells total depth to 50 feet above the base of the perforated interval and from 50 feet below the top to 100 feet above the top of the perforated interval;*

From the list above one may see that it is not directly stated that a well abandonment plug shall seal all annuli in all directions. Though it is stated indirectly by saying that the production casing must be cemented from the shoe to 500 ft above any hydrocarbon bearing stratum, and that the wellbore must be cemented from 50 ft below the top to 100 ft above the top. Since the wellbore is sealed from the top of the hydrocarbon bearing stratum and 100 ft above, it is not necessary to mention the need for placing the plug below where the formation may fracture due to pressure from below.

From the list above one may see that it is sufficient with one well barrier. NORSOK D-010 and BP group practice 10-60 demands a primary and a secondary well barrier.

The need for avoiding control lines in the abandoned hole is not addressed in the AOGCC, therefore it is possible to leave the tubing in the hole even if it has control lines.

### ***3.3 Compaction, Subsidence and Casing Deformations [24], [25]***

#### **3.3.1 Compaction and Subsidence in the Valhall field**

The chalk matrix of the Valhall reservoir has very high porosity and is quite soft. This has resulted in chalk production that leads to lost oil production and casing deformations. The primary production method has been pressure depletion. Since the chalk is very soft, the reservoir has compacted more than 10 meters in the center of the field and less towards the flanks. The compaction of the reservoir has both positive and negative consequences: Significant reservoir energy contribution from the compaction has been crucial to the increased recovery ratio. Partial transfer of compaction to the sea floor has led to seabed subsidence of about 6.3 meters in the field centre as shown in figure 11. The original platforms in the center of the field were not designed for this severe subsidence and the air gap is now too small. During the winter storms the wave height

gets so high that it reaches the cellar deck and destroys equipment on the platform. The original platforms must therefore be removed.



**Figure 10: The Valhall field center. [2]**

The newer WH, IP and PH platforms are constructed to withstand future subsidence. In figure 10, one can see that the air gaps for the new platforms are considerably larger than for the old platforms.

The compaction and subsidence have also resulted in casing deformations as experienced in similar fields. Even if there are a lot of challenges related to compaction, the benefits of the increased reservoir energy far outweigh the negative consequences. The subsidence rate was for a long time stable on 25cm/year. In 2004 water flooding was initiated to increase the reservoir pressure. On the nearby similar field Ekofisk, ConocoPhillips experienced increased compaction and subsidence due to water weakening of the chalk. Based on the experience from Ekofisk, increased subsidence was predicted on Valhall as well, but has not been observed. Actually the subsidence rate has been substantially decreased and for 2011 it was 12cm/year. This is believed to be due to very effective re-pressurisation of the Valhall reservoir and a thermo-chemical weakening mechanisms that are larger at Ekofisk reservoir temperature (130 degrees C) than at Valhall reservoir temperature (93 degrees C). Casing deformations are expected to be an essential part of the operational cost. Experience from other fields has indicated that compaction and the associated kinematics are not possible to stop. Therefore the best strategy will be to



extend well life as long as possible and at the same time utilize the extra reservoir energy from compaction.

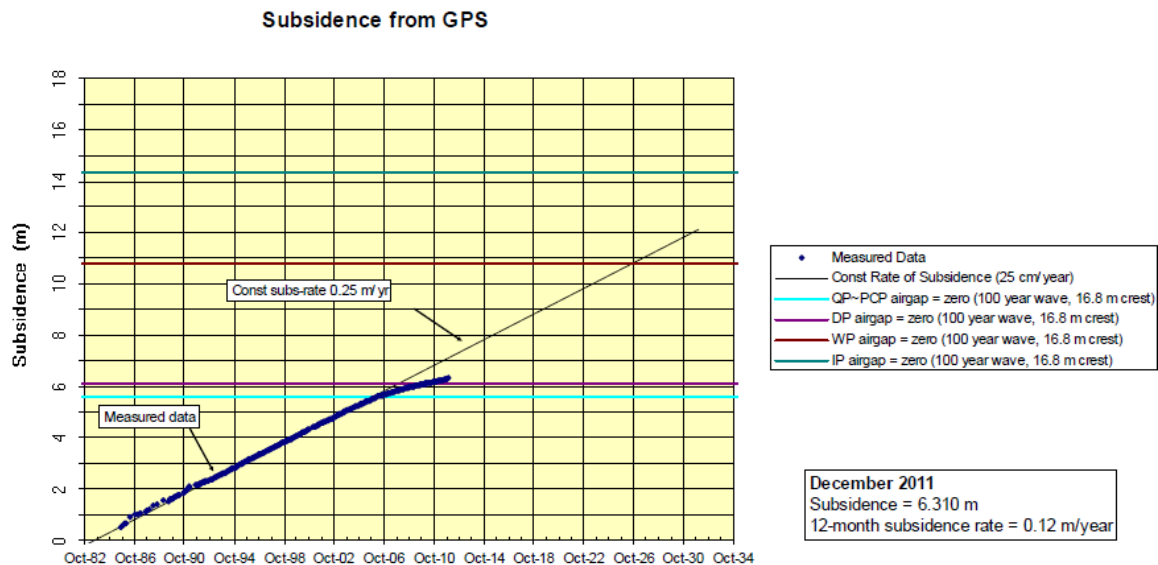

Figure 11: Subsidence on the Valhall field. [2]

### 3.3.2 Casing deformations

When designing casings one normally considers maximum potential collapse, burst, tension and compression loads during installation, during planned operations and due to unplanned leaks. The loads from deforming rocks due to oil and gas production are rarely addressed although this has caused loss of casing integrity at a number of occasions in the industry. Tubular deformations in oil and gas wells are mainly caused by volume change in the rock bulk volume surrounding the wellbore. The change of rock bulk volume is a response to stress changes resulting from pore pressure and/or temperature changes introduced to the rock mass during exploitation. If the reservoir and/or cap rocks are weak enough, this volume change may be large enough to cause casing deformations as shown in figure 12. Volume changes occurring in the reservoir rock will induce load redistributions both inside and outside the reservoir that may induce stress changes and volumetric deformations in formations quite far away from the initial deformation. Faults, fractures and joints are often found in rock masses, volumetric deformations may induce slip in these weak planes. Volumetrically deformed rock masses and shear displacement on weak planes will be transferred to the well construction. How much the casing is affected depends on the deformation properties of the rock, cement and the bond

strength of the cement to the steel and the rock. If the forces are strong enough to debond cement from one of the surfaces, the transfer becomes friction dependent. It may be challenging to calculate casing loads due to rock deformation because of uncertainties in estimating the strain at which debonding occurs and frictional load transfer. The casing deformations modes or combinations of these modes considered most likely in oil and gas exploitation is:

- Column buckling
- Tension
- Bending
- Cross-sectional crushing
- Shear

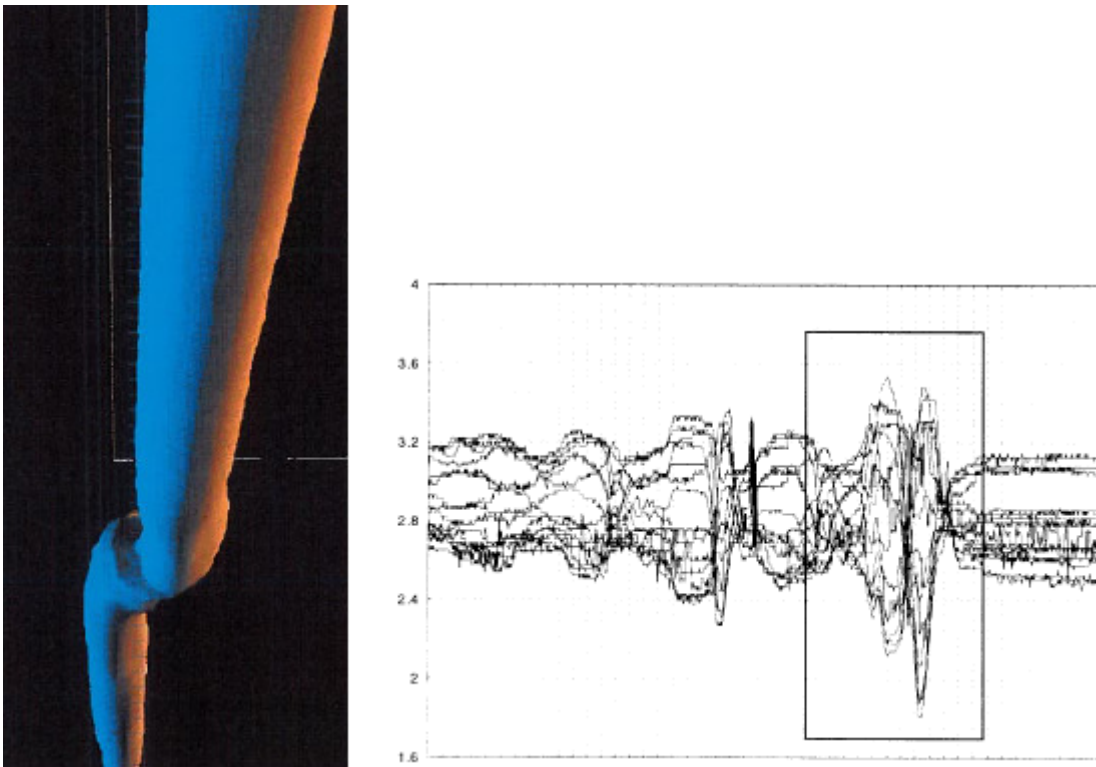

**Figure 12: Casing deformation [K. Bashford - Abandonment in Greater Ekofisk], [24]**

On the Valhall field, chalk influx was experienced as early as during exploration well testing. Together with tubular deformation chalk influx has been one of the main risks in the Valhall field development. A number of completion techniques have been proposed to optimize hydrocarbon extraction of the Valhall field. Severe casing deformation was

experienced in the reservoir already in 1984 after two years of production and in 1986 the first tubular deformation in the cap rock was experienced. Deformations in the cap rock are expected to be a result of reservoir compaction. Casing deformations are normally experienced in one or several of these sections on the Valhall field:

- The production interval with perforations
- The interval between the perforations and the cap rock
- The section at the top of reservoir/cap rock transition
- The section through the shallower overburden (up to 500 m above top of reservoir)

Several strategies have been proposed to mitigate the casing deformation challenges in the reservoir:

- Thick walled, heavy weight reservoir liners
- Oriented perforations shot at top/bottom of wellbore to increase resistance to chalk production
- Hydraulic propped fractures to maintain productivity and reduce pressure gradients in the near wellbore area
- Cement the liner overlap annulus 100%

In the nearby field Ekofisk casing deformations are experienced in both overburden and in the reservoir as well. When casing deformation data from Valhall is analyzed in a similar manner, the behavior is not similar to Ekofisk. One reason for this may be the frequent occurrence of large chalk influxes at Valhall. Several m<sup>3</sup> may be produced and causes rapid compaction close to the wellbore. This rapid local compaction can create a high strain rate on the cap rock surrounding the well, and trigger slip on a plane of weakness which is already loaded to its shear limit. The cap rock on Valhall is fairly soft and weak; the strain transfer from normal compaction may create a slow, non-localized creep similar behavior to the formation. When rapid chalk production occurs; faster strain pulses induces slip on weak planes with localized deformation as the result.

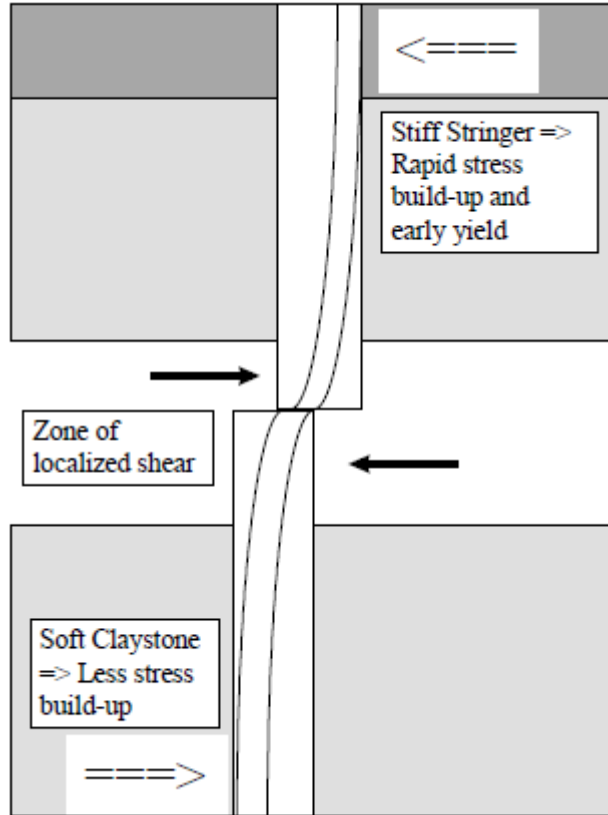

Figure 13: Localized casing deformation, [24]

Tubular deformations as shown in figure 13 on the Valhall field have had several consequences that have influenced the productivity, integrity and ability to re-enter a well:

- Productivity: When the tubing changes geometry and becomes tighter or even closed there will be restrictions towards flow. Less or no hydrocarbon production will be the consequence.
- Integrity: Casing and tubing deformations may lead to leakage in the tubulars. If this happens one of the well barriers may be lost and the well must be shut in.
- Re-entering well: Tubular deformations may cause restrictions in the well that are so severe that re-entering into the well is not possible.

As mentioned above, several of the Valhall crest wells have experienced severe tubular collapse. As of October 2000, 28 out of 102 production wellbores on the Valhall field center had been sidetracked due to tubular deformations. The current status of the remaining wellbores on Valhall DP is that 15 out of 30 wells have experienced collapse. Two wellbores are uncertain, meaning that they may have experienced collapse. There

are 13 wellbores that have not experienced collapse. These statistics may of course change based on the coil tubing well intervention campaign that is initiated in August 2012. [34], [39]

### **3.3.3 Tubular deformations and P&A**

As mentioned above, tubular deformations may cause severe problems re-entering the well. When plugging a well for permanent abandonment it is absolutely necessary to place the plugs deep enough so that the formation at the plugging depth is able to withstand the pressure it may be exposed to from below. If a severe restriction is located shallower in a well than the minimum plugging depth, a real challenge is present. As mentioned earlier, there are a lot of tubular deformations in the wells at the Valhall field, especially in those drilled from the field center (DP, IP and WP). Every effort must be made in order to make sure that the plugs are placed deep enough. Due to this challenge, a lot of possible solutions must be analyzed, including both new and well known technology. Some of the solutions may be:

- Milling through restriction
- Pumping expanding cement through the restriction
- Sidetracking and re-entering the wellbore, similar to a relief well
- Casing and Tubing opening tool
- Abrasive technology

## **3.4 Traditional Technology**

### **3.4.1 Section Milling [15]**

When abandoning a well there has to be placed permanent abandonment plugs that seals the wellbore in all directions including all annuli. In many wells is the casing where a plug shall be placed uncemented. In order to place a plug that meets the requirements mentioned above, one need communication from the wellbore to the annulus. The traditional way to do this is to section mill the required length of the casing, perform a clean-up run, underream the open hole and place a balanced cement plug. There are several challenges related to this process; Section milling fluids must be able to keep the open hole stable and transport swarf and debris to surface. The required weight and

viscosity may cause ECD values that exceed the fracture gradient, leading to losses, swabbing, well control problems, poor hole cleaning and packing off around the BHA. HSE challenges are present due to the handling and disposal of the generated swarf and debris. A permanent abandonment plug must be verified in the annulus at the depth of the plug. The verification of the sealing capability of the plug is difficult to assess. The section milling process has to be performed in several time consuming runs that makes it a costly process.

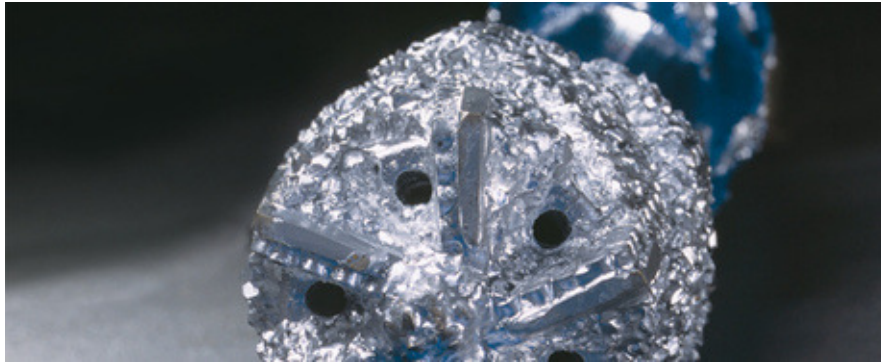

**Figure 14: Milling tool [www.BakerHughes.com]**

### **3.4.2 Cut and Pull [27]**

A traditional alternative to section milling, is to cut and pull casing. The idea is to find the point where the casing - formation annulus is lacking cement, cut the casing above this point and pull the casing out of the hole. The free point may be found in several ways, for example by using a logging tool. It is also possible to perform a stretch test, similar to finding the free point for a stuck drill pipe. Experience has shown that it may be challenging to remove the casing in one part. Several cuts and removals may therefore be needed, making the operation time consuming and costly.

### **3.4.3 Multistring conductor and wellhead removal [13]**

According to NORSOK D-010, the wellhead and multistring conductor shall be removed in such a manner that no parts of the well will ever protrude the seabed. The cutting depth should be 5 m below seabed. Traditionally the wellhead and multistring conductor is removed by utilizing a drilling rig and tools like knives and explosives. This operation can be both hazardous, inefficient, time consuming and expensive.

### 3.4.4 Control Line Removal [33]

As described in section 3.2.3, control lines clamped to the production tubing as seen in figure 15 may be a leak path for fluids to surface. Therefore, these must be removed before plugging and abandoning the well. The conventional way of doing this has been to pull the tubing out of the well. This takes some time and is also quite heavy work that leads to the need for a heavy operational rig. On Valhall DP most of the wells have control lines, finding a way to do P&A without pulling tubing could therefore have large value adding potential. In the first half year of 2009 an American company with office in UK, InterAct, performed a study on behalf of BP to investigate the potential for creating a window in the production tubing and control lines where a sufficient plug may be set. The study investigated existing & potential tool and technologies in the following categories;

- Explosives
- Chemical
- Mechanical
- Flame-based/ Electrical Arc
- Laser
- Abrasive grit/ water jet cutting



Figure 15: Control lines. [18]

Unfortunately none of the technologies investigated had readily available tools to meet the challenge of this study. The only tool with potential of meeting the challenge is mills

and under-reamers deployed on coiled tubing with a hydraulic motor. However, milling and under-reaming has a lot of issues like; achieving the necessary OD, holding control lines in place during milling to avoid “entanglement”, hole cleaning, HSE issues etc. The time and cost effectiveness of milling and under-reaming is also considered doubtful. Based on this study, pulling the tubing still remains as the best alternative in order to remove the control lines.

### **3.5 New Technology**

#### **3.5.1 Reduce section milling time [17]**

As mentioned above, section milling is a time consuming and expensive operation. According to NORSOK requirements, a plug has to be placed over a length of 50 m MD and seal both horizontally and vertically across the wellbore. In 2008, ConocoPhillips plugged and abandoned two wells on the Ekofisk Whisky platform. These wells needed section milling to be able to set a cement plug according to NORSOK req. The section milling of the casing was the operation that contributed most to the time used. The section had to be milled in three/four runs due to worn out knives on the mill. ConocoPhillips challenged the service company to develop a milling tool that could mill the entire section in one run, and thereby saving a lot of time. Baker Hughes came up with a solution that consisted of two new technologies:

1. New cutter design (see figure 16) - The traditional cutter design is made of randomly crushed, sintered tungsten carbide particles that are suspended in a special copper-base brazing-type alloy with high nickel content. In year 2000, another type of cutting material was introduced which improved milling. These inserts are designed to act much like crushed tungsten carbide, but are no longer randomly shaped. The newest cutter, the P-cutter, was introduced in 2009 and is a specifically shaped carbide cutter that is applied to a cutting surface, such as the blades on a section mill. This new type showed significant improvements compared to the traditional shaped cutters applied to milling blades. There are mainly two attributes to this improvement. One attribute is the new longer lasting material. The other attribute is the shape of the cutter. Because of the longer



- cutting edge of the cutter, the P-cutter is not susceptible to single point loading commonly seen on round shaped cutters.
2. Downhole optimization sub - This is a data collection sub that enables a better understanding of what is happening at the working depth of the BHA through downhole parameters together with surface data. The downhole optimization sub acquires downhole data such as, weight on tool, torque, rpm, bending moment, vibrations, pressure and temperature. The data is transferred real-time to surface and displayed on a rig floor monitor. The data may also be transferred real-time to town. In this way, field engineers, driller, intervention engineers, onshore engineers and experts may analyze the data in real time to enable better decisions for how to proceed.



**Figure 16: Milling blade with trad. cutter. and Milling blade with P - cutter. [17]**

The introduction of these new technologies on the remaining six wells led to safer and more effective milling operations saving a lot of rig time. The first two wells used an average of 65 days to be plugged and abandoned, while the last six wells used an average of 46 days to be plugged and abandoned. In total, the new technology saved ConocoPhillips 114 rig days compared to traditional section milling. With a jack-up rig rate of about 300,000\$/day, ConocoPhillips saved at least 34.2 million \$ due to the improved technology in this P&A campaign. The swarf from the new P-cutter is smaller and more consistent. This makes the swarf easier to circulate back to surface, reducing the chance of pack-offs and fracturing of the formation.

### **3.5.2 Hydrawell Intervention - Hydrawash [15]**

The Hydrawash plugging system perforates uncemented casing, washes the annular space and then places the cement across the wellbore cross section in one run creating a permanent abandonment plug. Just as in section milling, the mud weight must be able to

keep the well stable, but the high viscosity is not needed to transport metal swarf to surface. The Hydrawash system greatly reduces the potential for pack offs. In addition the lack of metal swarf creates a safer working area. Material disposal costs are also greatly reduced since special surface handling equipment is not needed, and onshore disposal of swarf is eliminated.

The Hydrawash system consists of a perforation gun on the bottom that is dropped after firing. Above the perforation gun is a cup wash tool. Washing operations are performed in the annulus across the perforated area and removes old mud, settled barite, spacer, basically everything that was left behind the casing. When the annulus is considered clean enough, the wash tool is placed in the hole below the perforations as a base for the cement job. On top of the wash tool, there is a cement stinger. The balanced cement plug is placed with the stinger at bottom. Depending on cement job design the cement can be squeezed into the perforations and pressure held until the cement has set sufficiently. The Hydrawash system creates an abandonment plug that can be verified in the annulus, unlike traditional section milled plugs. This can be done by drilling out the plug inside the casing and log the cement placed in the annulus. If the cement plug is drilled out, one has to place a new cement plug inside the casing and verify this.

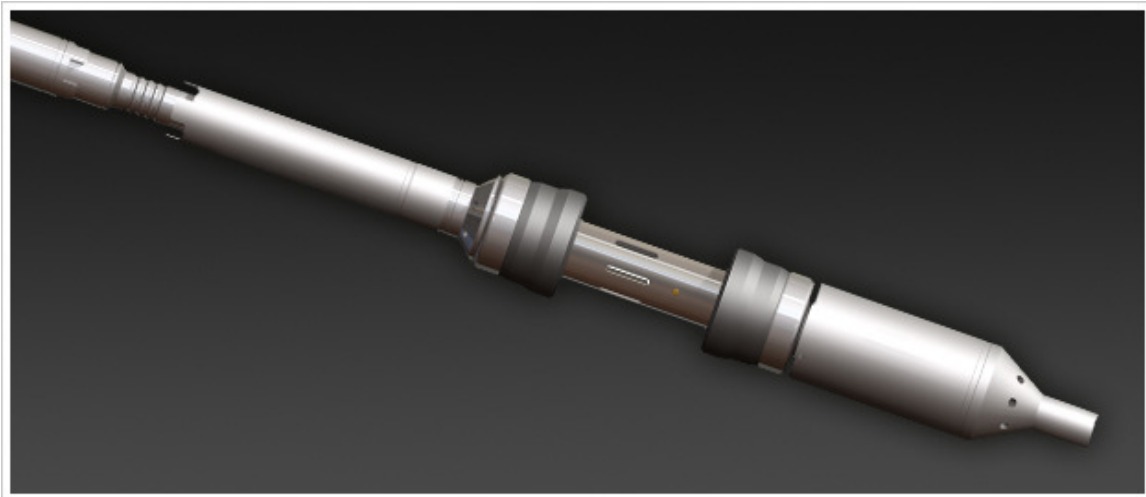

**Figure 17: The Hydrawash tool - [www.hydrawell.no]**

ConocoPhillips have used the Hydrawash technology quite a lot in their plug and abandonment operations the last couple of years with very good results. The time required for setting a conventional section milling plug was on average 10.5 days. With

the Hydrawash system the average time has been reduced to 2.6 days per plug. On the first twenty wells done for ConocoPhillips the Hydrawash tool saved an estimated 124 rig days. With a jack-up rig rate of about 300,000\$, ConocoPhillips has saved around 37.2 million \$ utilizing the Hydrawash technology on these first twenty wells.

### 3.5.3 Wellbore AS - Casing & Tubing Opening Tool [30]

In several fields on the NCS, unstable overburden and reservoir has caused collapse of tubing and casing in many wells. If the deformation is severe enough it may make the well unusable and the well must be sidetracked or permanent plugged and abandoned. Anyway, there might be a need for setting well barrier plugs below the point of deformation. If the deformation is severe enough, it may not be possible to run the necessary tools through the deformation. Wellbore AS is working with a solution of how to open a deformation enough and for a sufficient amount of time to plug of the well. Wellbore AS already has a tool for pulling stuck casing out of the well. The idea for the casing & tubing opening tool is more or less to turn this pulling tool around so that the force is used in a downward direction in stead of pulling upwards. The tool consists of two cones that are forced through the deformed section, creating an opening that plug and abandonment tools can pass through as seen in figure 18 below.



Figure 18: CTO tool - two cones forced through a deformation. [29]

So far there has been performed finite element analysis of opening different grades of deformation in different pipes with different steel quality. Later this summer (2012), workshop testing will be performed. [39]

### 3.5.4 NCA - Wellhead and Multistring Conductor Removal [22], [23]

As already discussed, the removal of the wellhead and multistring conductor has been a time consuming and hazardous operation. Due to this, the development of abrasive water jet cutting tools was initiated by NCA back in 2001. Test cuts were performed on Ekofisk in 2002 and commercialized with decommissioning of the Frigg platforms in 2003. During the last 8-9 years, over 400 conductor cuts have been done. The technology is now considered field proven for platform wells and a reliable method for subsea wells.

The abrasive water cutting technology can be performed on a range of vessels which reduces the cost of this operation greatly, since there is no need for a heavy work drilling rig.



**Figure 19: Multistring conductor cut performed with abrasive water technology. [www.nca.com]**

The wellhead and multistring removal technology consists of a purpose built wellhead connector and a stinger with the cutting nozzle at the lower end. The connector locks onto the outer profile of the wellhead, and the stinger is spaced out to achieve the correct cutting depth according to rules and regulations. The cutting tool assembly is operated from topside through an umbilical. The time needed for a typical cutting operation is from 4-12 hours depending on the depth, number and thickness of casings. The principle for abrasive water jet technology is to pressurize water containing abrasive particles up to between 60-120 MPa, and pump this slurry through a nozzle. The high velocity abrasive water jet cuts through steel and cement as seen in figure 20. The technology is field proven for cutting from 7" through 36" (see figure 19) and capable of cutting at water depths down to 500 m.

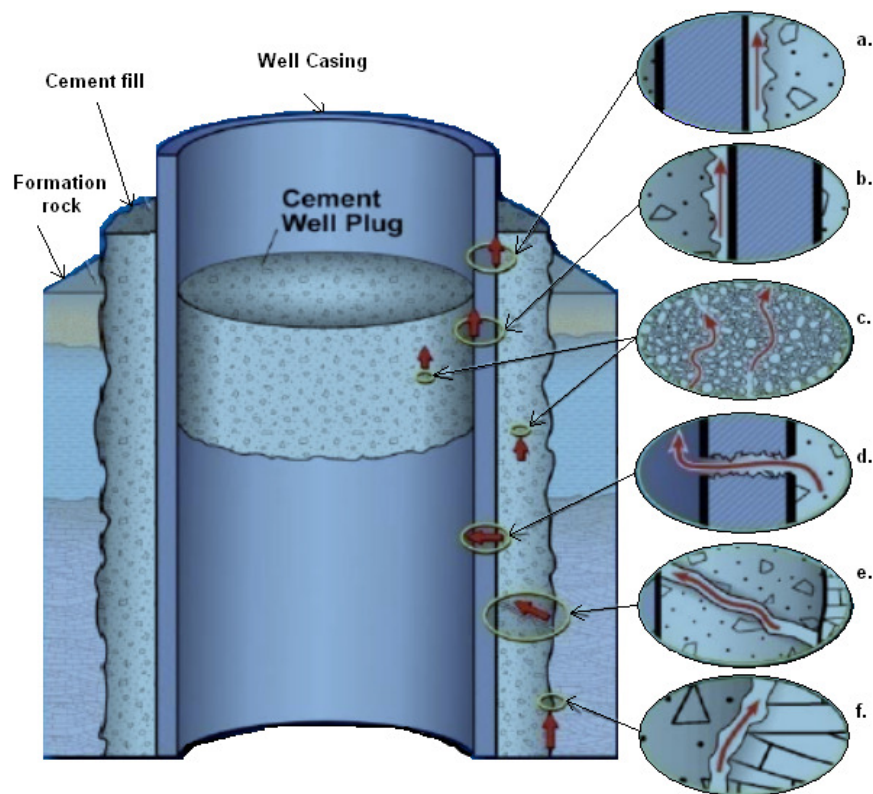

**Figure 20: Abrasive water cutting through steel. [www.nca.com]**

## ***Traditional Plugging Material***

### **3.5.5 Cement [18]**

Traditionally when abandoning a well, a series of cement plugs is placed to isolate the pressurized zones from each other and from surface. Cement is a well known material with properties well documented. However some of these properties are not ideal for handling well integrity challenges related leakage of pressure and fluids. These are: Shrinking of cement, gas migration during setting, fracturing after setting and long term degradation by exposure to temperature and chemical substances in the well.



**Figure 21: Cement problems - [18]**

Figure 21 shows several of the problems with cement. a), b) and f) shows leak paths that has occurred due to poor bonding between cement and casing/formation. c) Shows how fluids may migrate due to fracturing of the cement, making it permeable. d) Shows how leakages may occur due to casing failure and e) shows how a flow path may be created in the cement due to gas migration during hardening.

### **3.6 New plugging materials**

#### **3.6.1 Sandaband [16]**

Sandaband is a Bingham-plastic unconsolidated plugging material with high solids concentration (about 75%). The remaining volume consists of water or brine that gives sufficient hydrostatic head when the Sandaband is in the fluid phase. Sandaband does not set up and therefore it does not shrink, this contributes to making it gas tight. If shear forces exceeds the Sandabands strength it does not fracture, it re-floats, and shear forces are reduced below yield strength causing the plug to reshape as seen in figure 22 below.



**Figure 22: Sandaband in solid phase refloated to liquid phase. [Sandaband presentation from P&A forum 09.06.2011]**

This process is purely mechanical so that the transition from solid to fluid to solid again may be repeated forever. The sealing property is the solids particle size distribution and bound water only, making the plug thermo-dynamically stable. The particles are packed closely and absent of free water, making sure that the entire column is kept homogenous and that no re-distribution of particles occurs. This means that the Sandaband slurry will be gas tight and prevent influx to the wellbore forever.

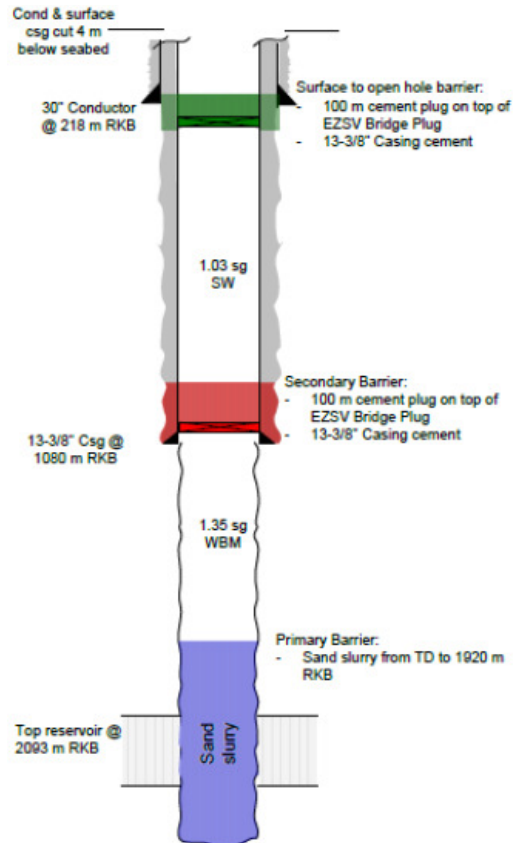

**Figure 23: PP&A schematic on the 25/8-17 exploration well using Sandaband. [16]**

The Sandaband slurry has been used for permanent P&A at least one time before by Det Norske on the exploration well 25/8-17 located on the Norwegian side of the North Sea as shown in figure 23. The operation was accomplished in a safe and successful manner. The operation was carried out without down time and used sufficiently less time than the traditional operation time for setting a cement plug. The time saved is mainly due to time waiting for cement to settle and no need to change to a cement stinger. About one day of rig time was saved in total for setting one plug. With the rig hire being around 500,000\$ for a semi-sub this clearly displays the cost efficiency potential in Sandaband. Sandaband is a bit more expensive than cement, but the saving in rig time was sufficient for Sandaband to pay for itself. BP Norway has used Sandaband on several occasions to reduce sustained casing pressure in collapsed wells at the Valhall field. This has been done by setting a WL - plug as deep as possible in the tubing. Then, the tubing is perforated and Sandaband is circulated through the perforation into the annulus. Sandaband is also left on the top of the WL - plug inside the tubing. Sandaband is often more dense than the fluid in the annulus, this makes the Sandaband slurry sink towards

the bottom of the well. As shown in figure 24, this sump allows the sand slurry to fall into it, thereby reducing the effect and leading to a shorter wellbore sealing Sandaband plug than planned above the perforations.

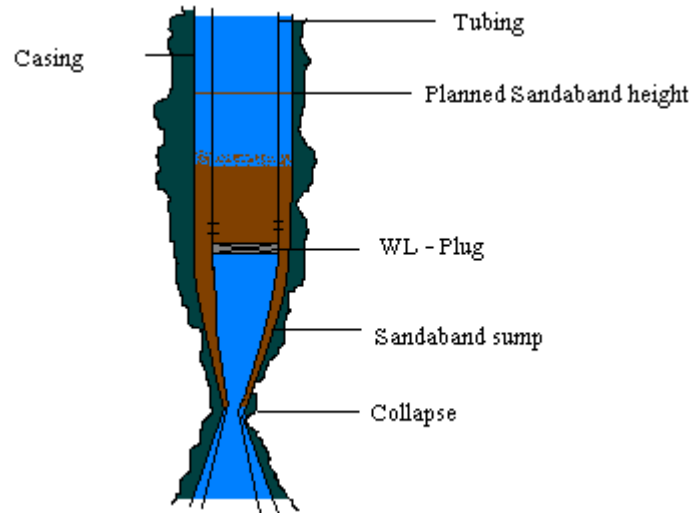

Figure 24: Sandaband sump in collapsed well

### 3.6.2 CannSeal [19], [20]

CannSeal is a new annular zonal isolation technology that has been under development for a few years and is about to be launched. As of May 2012, an application for using the new material is being sent to the Climate and Pollution agency (KLIF) for approval. The material used in the CannSeal technology is an epoxy that can be purpose designed for different operations. The CannSeal service is intended to provide a downhole annular seal. The sealant can be deployed both in an open annulus or gravel/proppant pack.

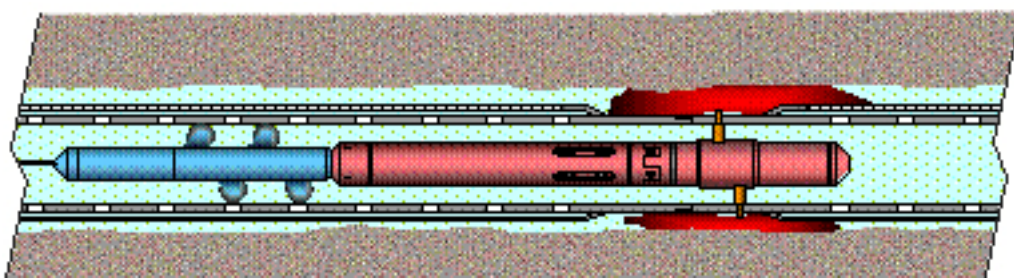
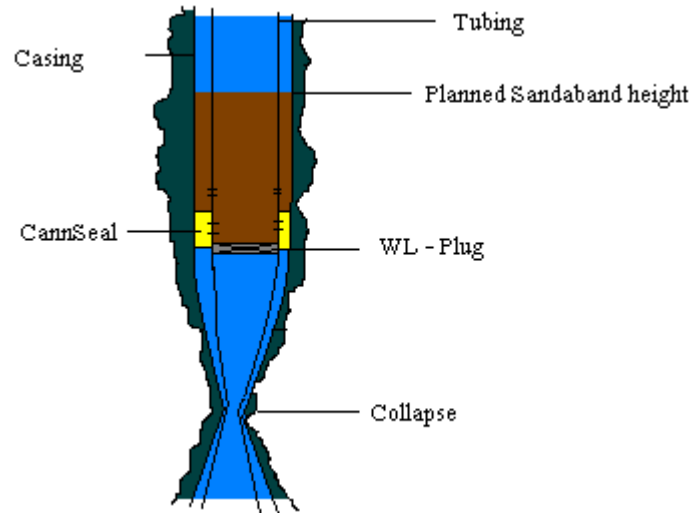

Figure 25: The CannSeal technology - Injecting sealant. [[www.agr.com/Our-Services/CannSeal/](http://www.agr.com/Our-Services/CannSeal/)]

The CannSeal system has several applications. Among others are: Sealing unwanted cross flow, sealing water/gas - breakthrough, sealing off leaking packers, sealing off annulus between two pipes, replacing “spot on” cement squeeze, spotting acid and form a basement for plugs sealing both the wellbore and annulus. The latter one is the



application most relevant for this thesis. As discussed in the section about Sandaband, the sump effect may be a challenge when setting a plug in an annulus without a foundation. The CannSeal system can be a solution to this problem as described in figure 26.



**Figure 26: CannSeal as foundation for annular Sandaband plug.**

This methodology can of course also be used as a foundation for permanent annulus P&A plugs in cases where the casing is un-cemented. An idea can be to combine this technology with the Hydrawash technology. The CannSeal technology is run on WL and consists of a perforating gun that creates communication with the annulus. When communication is achieved, the injection pads locate the perforations and the tool injects the sealant which is an extremely viscous “dow-like” epoxy that fills the entire circumference of the annulus in about 1 m length as shown in figure 25.

### 3.6.3 ThermaSet [21], [18]

ThermaSet is a polymer based resin that is an alternative material to cement. The resin is a fluid when being pumped, but sets up and becomes solid at a predesigned temperature. The viscosity and density of the material may be adjusted over a large range, viscosity from 20 - 600cP and density from 0.65 - 2.5 S.G. by using different fillers.



**Figure 27: ThermaSet samples**

The ThermaSet material does not need any extra equipment on the rig as it can be pumped using conventional cement pumping equipment. Once the plug is thermally activated to set, it hardens within a predesigned time from 15 minutes to two days. The ThermaSet material may be a solution to several challenges, such as: Lost circulation, casing cementing, shut off water/gas, micro annulus / well leakage, ..., P&A and balanced plugs. Since the material does not shrink during curing, it is ideal for operations with an eternal time perspective. The ThermaSet material is impermeable, has high compressive and tensile strength, and is ductile. All of these properties are listed as needed in NORSOK D-010. The ThermaSet material has been long term verified by SINTEF in a long term integrity test with 500bar and 130°C in separate environments of crude oil, methane, H<sub>2</sub>S and CO<sub>2</sub>. Since the viscosity of the ThermaSet can be really low, it is possible to get it through narrow restrictions i.e. partly collapsed or deformed wells. This has been done with success in some occasions for ConocoPhillips at the Ekofisk field. The ThermaSet material is more expensive than cement, but the price may in some cases be justified by less setting time and increased long term quality.

### **3.6.4 Verifying shale as an annulus barrier element [26], [18]**

The phenomena that rock in certain formations begins to move inward has for a long time been considered as an undesirable effect. The inward creep of rock may create problems when drilling a well or running casing. In plug and abandonment, a desirable effect of this inward motion of certain rocks (shale) is that it may create an annulus barrier according to the NORSOK D-010 standard in an uncemented annulus. If the annulus is uncemented, the traditional way to achieve a full cross sectional wellbore barrier has been

to section mill the casing before setting a wellbore cement plug. If the annular formation could be verified as a barrier element, the need for section milling is avoided and a much cheaper and safer operation is achieved. In order to use shale as a permanent plug and abandonment annular barrier, four criteria must be satisfied:

- The sealing rock must be verified as shale
- The formation must seal the entire wellbore (360 degrees) over a minimum length of 50 mMD and 30 mTVD.
- The fracture strength of the formation must be high enough to withstand expected pressure from below (for eternity).
- The displacement mechanism of the shale must be suitable to preserve the well barrier properties.

These steps may be verified by:

- Ensuring geological data indicates good shale presence
- Run ultrasonic & CBL/SBT logs
- Perform LOT to assess formation fracture pressure
- Communication test as described in section 3.2.3. permanent abandonment of wells, and in figure 28.

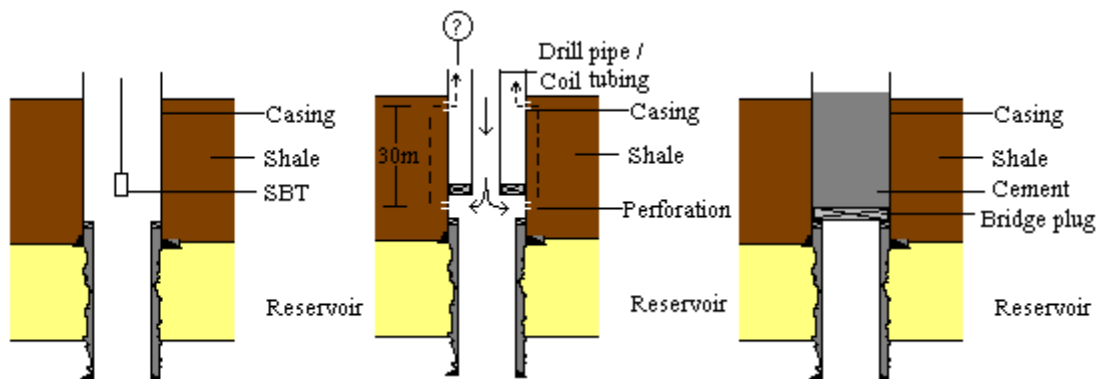

**Figure 28: Verifying shale as annulus well barrier**

Shale as an annular well barrier element has been approved by the PSA. Statoil has carried out over 40 P&A operations where shale as an annular well barrier element has been analyzed. In 90% of these operations, the shale has proved to have sufficient properties to be verified as an annular well barrier element. This method and technology

is documented by Statoil and Schlumberger in SPE paper 119321, *Identification and qualification of shale annular barriers using wireline logs during plug and abandonment operations*.

### **3.6.5 Settled Barite [36]**

ConocoPhillips encountered problems when attempting to pull casing strings in a section without cement during P&A operations on the West Ekofisk and Edda platforms. During primary cementing of these sections, water based mud (WBM) had been present in the well with barite as weight material. When the WBM is sits static over a long period of time (years), originally suspended barite settles out and forms a layer of barite above the casing cement.

In order to verify settled barite as a well barrier element, a number of conditions have to be satisfied:

- WBM containing barite has to be used for the drilling phase
- The well must have experienced static conditions over a long period of time, and no history of annulus pressure build up.
- The well should be relative vertical. In a horizontal well, barite will settle out on the low side of the well and leave a channel on the top side.

ConocoPhillips has internally qualified settled barite as a permanent barrier element.

#### 4 Potential sources of inflow [28], [39]

According to requirements in both NORSOK D-010 and BP Group Practice 10-60 zonal isolation, reservoirs containing hydrocarbons shall have at least one primary and one secondary well barrier. BP Norway's overburden expertise have identified as much as four zones at the crest of the Valhall field that potentially must be plugged according to the requirements mentioned in section 3.2.3; Permanent abandonment of wells. In figure 29. is a general overview of the Valhall subsurface shown. The input from the overburden expertise is summarized in the following:"

- *Pliocene/Quaternary comprises near-seabed aquifers and sands with some biogenic gas at hydrostatic pressure. Very extensive channel systems in shallow sections mean communication with seabed via faults/fractures is likely over geological time. Plug required to span shallow zones above 450m TVD and as far to surface as practical (to enable cutting/pulling of conductors).*
- *Late Miocene is accepted as being boundary of major thermally matured hydrocarbons (below) and biogenic gas (above). Overpressure increases around 900m TVD, and can manifest itself as in the G-10 high pressure gas sand stringer.*
- *Intra-Mid Miocene diatomaceous sediments are hydrocarbon bearing although permeability is very low (<1mD). It has not been evaluated as a viable reservoir, but in-place volumes (due to thickness and fracture porosity) are crudely estimated to around 550mm bbls. Plug required above 1430m TVD.*
- *Tor / Hod form main reservoirs with significant residual hydrocarbon saturation. Plug required above and as close to top of Tor as possible. Flow between the Tor and Hod is acceptable at the time of final well abandonment."*

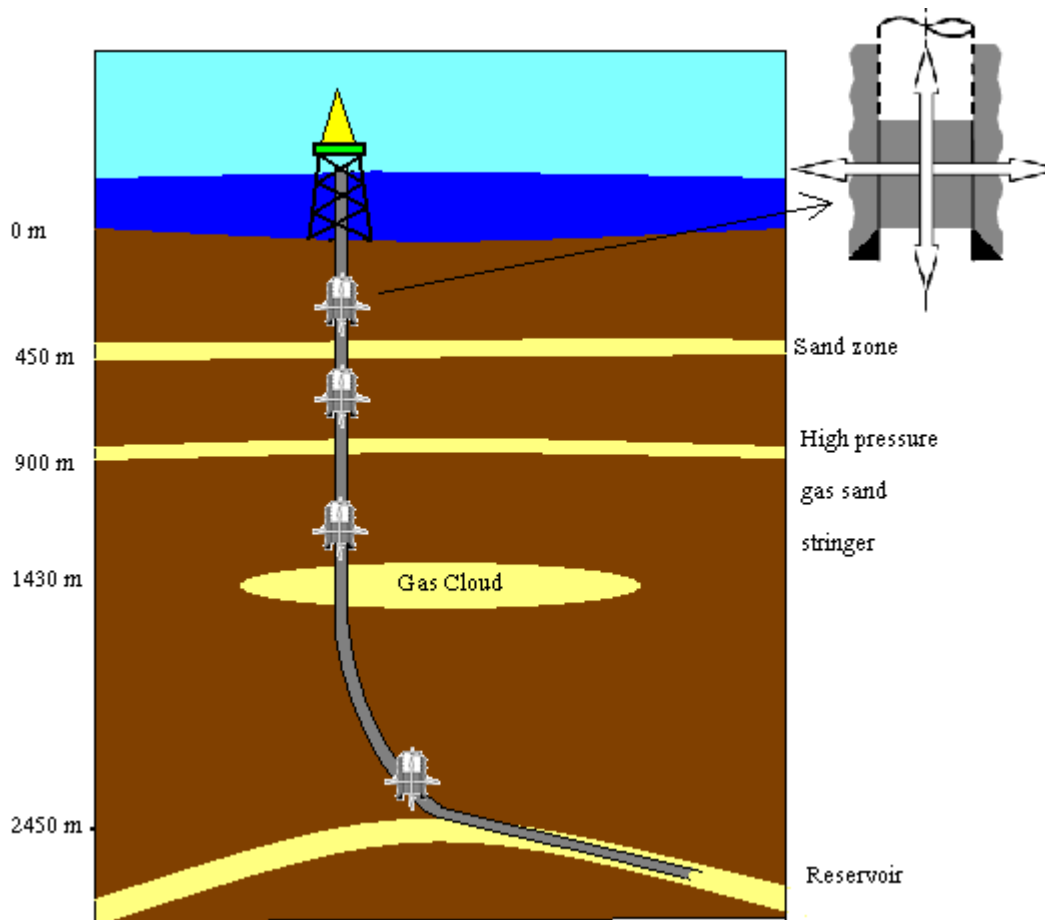

Figure 29: Zones that must be plugged at the crest of the Valhall field

## 5 Minimum depth for top of a secondary plug [40]

As discussed in section 3.3, it may be difficult to re-enter several of the wells in the Valhall field due to tubular deformations. To meet the requirements from both BP GP 10-60 and NORSOK D-010, well barrier plugs must be set deep enough so that the pressure from below does not fracture the formation at the secondary plug. Here is a difference between NORSOK and BP requirements. NORSOK states that the secondary plug shall be positioned such that the base of the plug is at a depth where the formation is strong enough to withstand the potential pressure from below. BP's requirement is at the top of the secondary plug, which is a little stricter.

A well that is permanently plugged shall be plugged with an eternal time perspective. The pressure in the reservoir will not necessarily stay the same as it presently is. At the Valhall field, waterflooding was initiated in 2004/2005 to increase reservoir pressure. The maximum waterinjection pressure will be 6200psi. Free gas will go back into solution at around 4500psi and most of the oil in the reservoir will be exchanged with water. The source rock for the hydrocarbons is still generating hydrocarbons. If oil or sea water will be used as the fluid gradient between the reservoir and the abandonment plugs will be discussed later by the reservoir team, but it is likely that the oil gradient is chosen. The aquifer in the field is very weak and it will therefore take a long time before the pressure will be back up to virgin pressure. The reservoir team has estimated the maximum reservoir pressure to be 6665 Psia at 2664 mTVD RKB. The minimum depth for the top of a secondary plug is found from the following calculation:

$$P_{\text{frac}} = P_{\text{well}}$$

$$\text{TVD}_{\text{plug}} * \rho_{\text{frac}} = P_{\text{res}} - \rho_{\text{well}} * (\text{TVD}_{\text{res}} - \text{TVD}_{\text{plug}})$$

$$\text{TVD}_{\text{plug}} = (P_{\text{res}} - \rho_{\text{well}} * \text{TVD}_{\text{res}}) / (\rho_{\text{frac}} - \rho_{\text{well}})$$

$P_{\text{frac}}$  - Formation fracture pressure, [Psi]

$P_{\text{well}}$  - Pressure from below at a certain depth in the well, [Psi]

$P_{\text{res}}$  - Maximum anticipated reservoir pressure, [Psi]

$\text{TVD}_{\text{plug}}$  - Minimum depth to top of a secondary plug, [m RKB]

$\text{TVD}_{\text{res}}$  - Depth to top of reservoir, [m RKB]

$\rho_{\text{frac}}$  - Formation fracture gradient, [Psi/m]

$\rho_{\text{well}}$  - Fluid gradient, [Psi/m]

The formation fracture gradient is made generic by analyzing leak off tests (LOTs) from the field. In order to calculate the minimum depth to the top of the secondary reservoir plug, a spreadsheet has been made (Appendix A.) The results are shown in figure 30. The top of the secondary reservoir plug has been calculated to be at:

- Gas gradient:  $TVD_{plug} = 2424,1$  m RKB
- Oil gradient:  $TVD_{plug} = 2343,6$  m RKB
- Sea Water gradient:  $TVD_{plug} = 2251,7$  m RKB

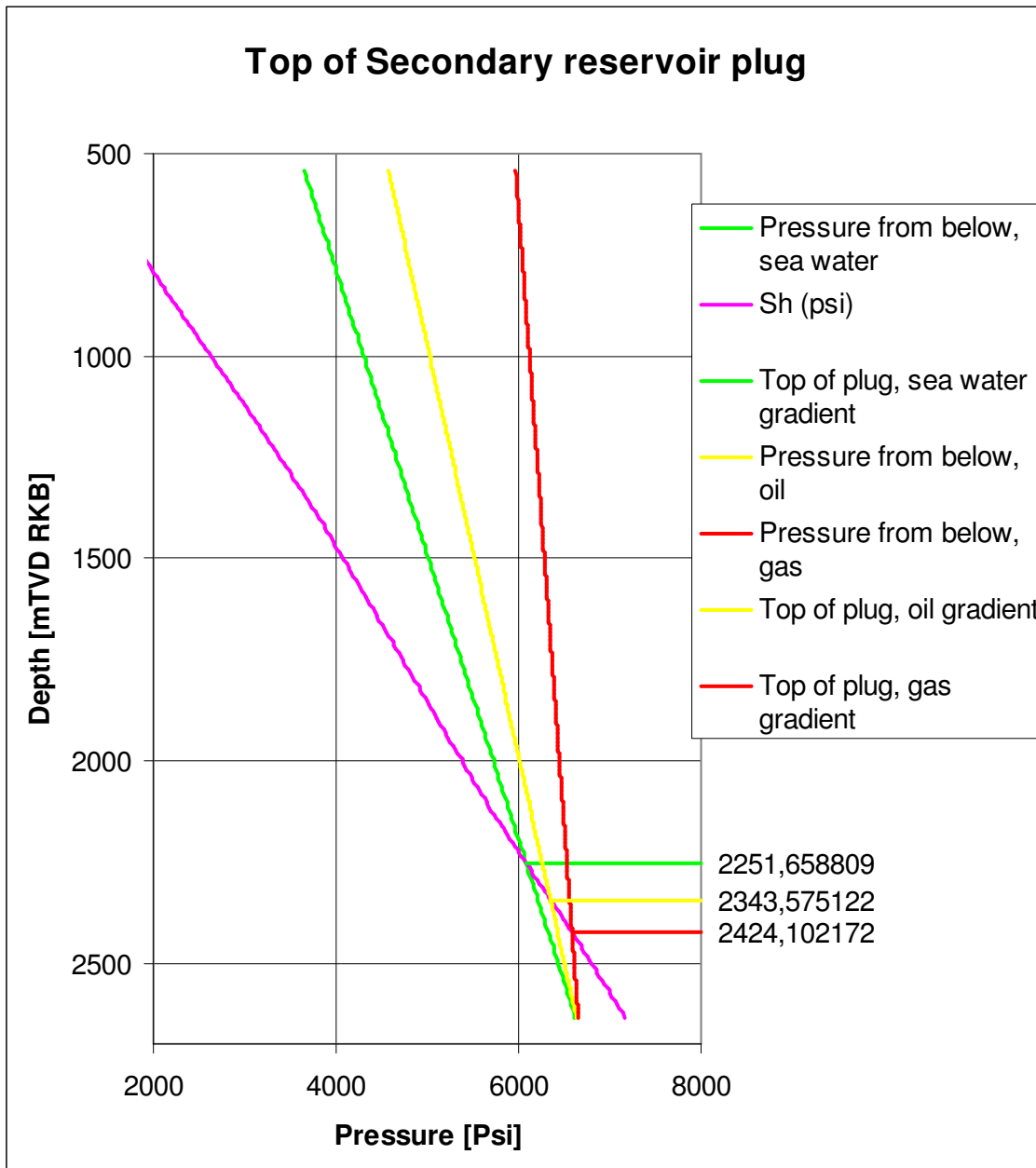

Figure 30: Minimum depth to top of secondary reservoir plug with different fluid gradients.



## **6 Well Categorization [39]**

The wells on Valhall DP will be categorized based on wellbore accessibility and well design. As described in section 3.3, compaction and subsidence has caused severe casing and tubing deformations in several wells. Due to the weak chalk reservoir, solids production has been present and may have caused restrictions in the wells, the restriction may also be due to scale. A lot of different well design alternatives have been implemented to cope with the dynamic field properties over time as described in section 2.4. When looking at some of these different alternatives, it is obvious that priority was put on production and not plug and abandonment. To be able to plug and abandon the Valhall DP wells as safe and cost effective as possible, it is of high importance to know the status of the wells. By dividing the wells into separate categories, it is possible to get an overview of the challenges ahead and therefore make better plans and decisions. Wells are categorized by wellbore accessibility and well design because these parameters will have great influence on the cost of the total operation and how the operation will look like. Today, there is production from 10 out of 30 wells on DP. In many of the wells there is limited amount of information about the current status of the wellbore. Some of the wells haven't been entered into for several years. In August 2012, a coil tubing intervention campaign will be initiated on Valhall DP. This campaign will give valuable information about the present status of the wells.

### **6.1 Well Design**

#### **6.1.1 Wells with Annulus Cement**

These are classified as wells where the casing / liner towards the formation where the well barrier shall be placed has been sufficiently cemented in the annulus. The top of cement (TOC) has in many wells been estimated based on the amount of returns during the cement job. This method does not give an accurate TOC and does not say anything about the bonding between formation/cement/steel. Therefore, a cement bond log (CBL) or similar should be performed in order to verify the TOC and that there is no fluids present. If the annular cement job is verified according to NORSOK D-010 and BP GP 10-60 as an annular well barrier, it will be sufficient to plug the wellbore on the inside of the casing in order to meet the requirements listed in section 3.2.3 as seen figure 31.

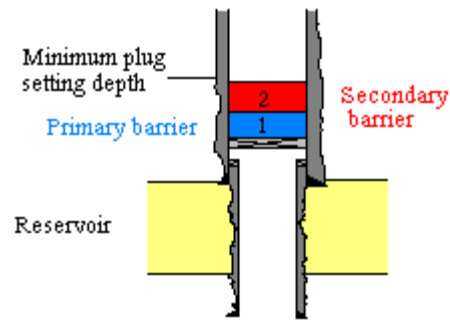

Figure 31: Reservoir well barriers in well with annular cement.

### 6.1.2 Wells without Annulus Cement

Wells where the casing / liner towards the formation where the well barrier shall be placed has been insufficiently cemented. In order to place proper well barriers, the entire wellbore and all annuli in all directions must be sealed off according to section 3.2.3. Wells in this category must in some way achieve an annular well barrier. In figure 32 has well barrier plug been set across an uncemented annulus.

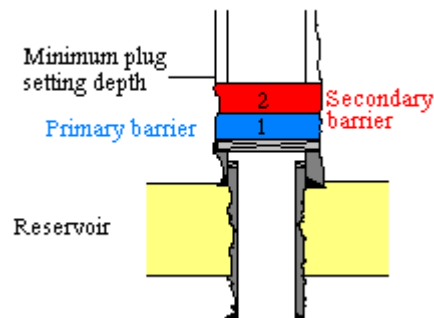
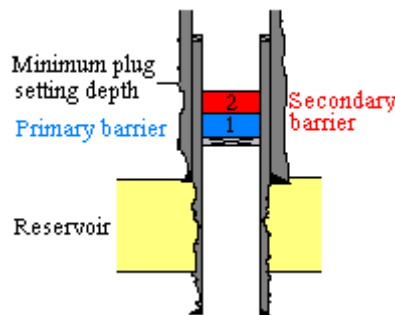

Figure 32: Reservoir well barriers in well without annular cement

There are several ways of doing this. The traditional way has for a long time been to section mill the casing and place a balanced cement plug against the formation. As more and more wells are being plugged and abandoned on the NCS, innovative options has been invented such as the Hydrawash (section 3.5.2) and CannSeal (section 3.6.2) etc. that can contribute to cope with this challenge in a safe and more cost effective way than the traditional section milling and balanced cement plug. The results have not always been good and verification of a good barrier is not easy.

### 6.1.3 Wells with heavy wall liner overlap, with annular cement

In order to cope with the many collapsing wells due to compaction of the reservoir and movements in overburden, heavy wall liners were installed. When drilling these wells, the common procedure is to drill a liner a couple of meters into the reservoir, then drill out the reservoir and place a heavy wall liner through the reservoir and overlap 3-400 m TVD into the drilling liner. The heavy wall liner has 1.0" wall thickness. The area where the two heavy wall liners are overlapping each other is often the area where the P&A reservoir well barriers have to be placed. As long as both liners are sufficiently cemented according to section 3.2.3, it is only necessary to place well barrier plugs inside the casing as shown in figure 33.

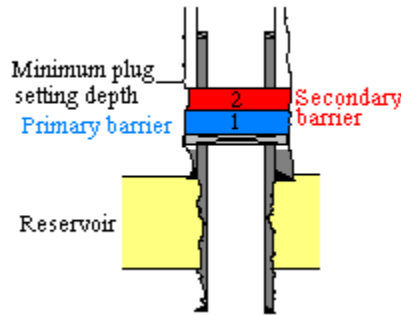

**Figure 33: Reservoir well barriers in well with heavy walled liner overlap and annular cement.**

The problem is to verify (log) the annular cement behind the first drilling liner since this is hidden behind two liners, possibly with cement between them. As of today there is no logging technology that is able to do this. A tool like this could also be used to verify shale as an annular barrier. Logging tools of today can only log through 0.8" steel.

### 6.1.4 Wells with heavy wall liner overlap, without annular cement

For wells with the heavy wall liner overlap and either insufficient information about the annular cement or no annular cement, communication between the wellbore and annulus must be created over a length long enough to plug the reservoir according to section 3.2.3, and shown in figure 34.



**Figure 34: Reservoir well barriers in well with heavy walled liner overlap, without annular cement.** This is challenge that has not been tried solved before. As of today, it does not exist a tool that can perforate, wash and cement effectively through this combination and den verify is the barrier is good or not. Section milling is therefore the only alternative so far, but section milling a 1.0 inch thick heavy wall liner, possibly with cement outside, and then another liner will be a time consuming, expensive operation with challenges regarding swarf handling and HSE aspects. This highlights the importance of new technology that is able to “see” through several annuli and new technology to replace section milling.

### 6.1.5 Well design summary on Valhall DP wells

A review of the well design on the 30 wellbores on Valhall DP has been made and shown in Appendix B. As shown in the spreadsheet there are:

- 2 wells in the “Wells with annulus cement” category
- 2 wells in the “Wells without annulus cement” category
- 12 wells in the “Wells with heavy wall liner overlap, with annular cement” category
- 12 wells in the “Wells with heavy wall liner overlap, without annular cement” category

In the spreadsheet it is also shown that two of the wells never entered the reservoir. Well 2/8 -A-8-C never reached the reservoir due to technical challenges. Well 2/8-A-13-C is a waste injection well into Late Oligocene at 1886 mTVD and never intended to reach the chalk reservoir. However, the shallower sources of inflow must be plugged and abandoned for these wells also.

## **6.2 Well Accessibility**

### **6.2.1 Full reservoir access**

Wells where there are no problems running tools through the tubing and into the reservoir, no or only small amounts of solids / fill are encountered going down the well. These wells will not need extra P&A preparatory work such as clean out of solids or opening of deformations. Wells that are found like this during the CT campaign in the fall of 2012, will get a mechanic plug installed above the reservoir and cement will be placed on top as a good foundation for further P&A work.

### **6.2.2 Fill in tubing**

These wells are characterized as wells that have so much fill in the tubing that it is not possible to run tool through the fill and into the reservoir. During the CT campaign, these wells will be cleaned out so that it is possible to get as far down into them as possible and practicable. Since Valhall is a chalk reservoir, an acid solution containing about 15% HCl can be used to dissolve the chalk if normal clean out is difficult. If it is possible to reach the reservoir after cleaning out the well, the same operation as mentioned above for wells with full reservoir access will be performed.

### **6.2.3 Partly collapsed well**

During the CT campaign, a 2 7/8" CT string will be used with a 3 1/2" bit rotated by a downhole motor. If this tool encounters a collapse and is able to get through, the well will end up in this category. If the well is designed in such a manner that tools with larger outer diameter than 3 1/2" is required to get through the collapse, it may be moved to the fully collapsed well category.

### **6.2.4 Fully collapsed well**

If the CT tool is not able to get through a collapse, the well will end up in this category. Wells in this category may be very difficult to get communication to the reservoir. There is a lot of uncertainty considering both operational method and time consumption to get through the collapse. In section 7, a review of different operational methods to get through a collapse is given.

## 7 How to get through a collapsed section [39]

In collapsed wells, it may be difficult to reach sufficient depth to set a competent well barrier plug according to NORSOK and BP requirements. Below are some different alternatives of how to get through a well collapse.

### 7.1 Casing/Tubing opening tool [30]

In order to re-open collapsed wells, Wellbore AS is working on a tool called the Casing Tubing Opening tool. This tool is described in section 3.5.3, and in figure 35.



Figure 35: Re-opening collapse with Casing/Tubing Opening tool.

BP is supporting Wellbore AS in commercializing this product. There are high hopes that this tool will be able to re-open many of the collapsed wells on Valhall DP for a sufficient amount of time to set competent well barrier plugs below the collapse. The finite element analysis that has been performed has shown that the tool will have problems to re-open deformations over a certain percent, depending on which steel quality the collapsed casing has. If this tool won't be able to re-open the collapse, more time consuming alternatives will be tried.

### 7.2 Abrasive technology

BP is supporting a study to investigate the possibility of utilizing the principle of abrasive water jet cutting to get through a collapsed section of a well. In section 3.5.4, a wellhead and multistring conductor removal tool is described. The pressurized water containing abrasive particles are pumped perpendicular to the tubular. The idea is to point the jet in a

downward direction so that the collapsed section is removed and the cuttings, which are believed to be more “powder like” than “cuttings like”, are circulated to surface. This avoids the need for special swarf equipments on the rig. There will also be less probability of encountering well control problems due to high ECD. It is believed to be possible to point the jet downwards in a controlled manner as it is conveyed on drill pipe or coiled tubing.

### **7.3 Extreme Expandacem [37]**

To cope with the challenges of shrinking cement, one may add additives that make the cement expand in stead. Halliburton has initiated lab testing to explore the possibilities of adding large amount of the expanding material and set a plug through the collapsed section to see if it is possible to re-open the collapsed section with expanding cement. If the tubular is re-opened, the cement can be drilled out and one may reach the necessary depth.

### **7.4 Milling [38]**

Milling is a technology that has been used for a long time and is well known. A typical mill set up to remove a collapsed section is to have a taper mill in front, followed by a water melon mill as shown in figure 36. Milling may be conveyed on both drill string and coiled tubing.

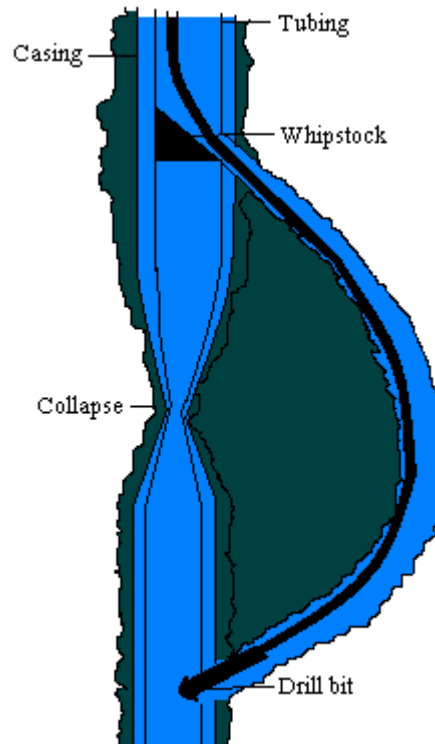

**Figure 36: Water melon mill and Taper mill. [38]**

As discussed earlier (section 3.4.1), milling has some disadvantages with regards to time consumption, HSE, well control etc... Another challenging disadvantage with milling is that the mill will take the direction of least resistance. This can result in unplanned sidetracking of the wellbore.

## 7.5 Sidetracking

In some cases one may not be able to get through the collapse, or the collapse is so severe that there is no connection from above the collapse to below it. In these cases, a last resort can be to sidetrack the original wellbore and drill back into the wellbore below the collapse as seen in figure 37.



**Figure 37: Sidetracking to re-enter below collapse.**

Sidetracking may also be an unwanted result of a milling job. To be able to re-enter the original wellbore, one will have to use some kind of magnetic tool close to the bit that can sense where the original casing is and enable the directional driller to steer towards it and re-enter it. Sidetracking and re-entering of a wellbore will be a very costly and time consuming operation where there is no guarantee for success.



## 8 Generalized Operational Procedure [39]

In order for the plug and abandonment of the Valhall DP wells to be as cost efficient and safe as possible, it is necessary to come up with a general plan for all the wells. By dividing the P&A work into campaigns for several wells at the time, synergy effects in several areas may be obtained. The proposed P&A campaign is to first do as much rigless work as possible on all the wells. Then the rig arrives to do the heavy work on all of the wells, before the wellheads and multistring conductors are removed with abrasive cutting in a rigless campaign. In appendix C, a more detailed operational procedure for P&A of a specific well is proposed. This well is a typical Valhall DP well with heavy wall liner overlap. There has not been observed any collapse in this well, but the well diagnostic may prove otherwise. The reader is encouraged to read this appendix in order to better understand the operational procedure.

The well schematic below (Figure 38) shows a typical Valhall DP well which will be used as example in describing the work which can be done in the various campaigns.

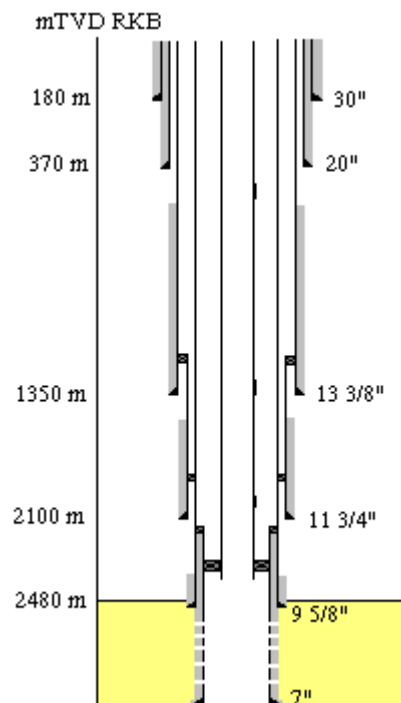

**Figure 38: Typical Valhall DP production well with liner overlap and partially cemented annulus.**

## 8.1 Rig less work

For all Valhall DP wells, the first operation will be performed rigless. Doing this enables better planning of the upcoming work so that the rig time can be used more effective.

### 8.1.1 Well diagnostics

The first step in a plug and abandonment operation is to find out how the condition the well actually has. Many of the wells haven't been entered into for several years. As described in chapter 6, the wells will be categorized into various categories depending on their accessibility and design. The way the well is designed is already known, but the accessibility may have changed since the last time the well was entered into. As also described in chapter 6, the way the well will be plugged and abandoned is depending on which category it falls into. A well diagnostics campaign on the Valhall DP wells has partly been done in 2011 and early 2012, and will be continued during the fall of 2012 and into 2013.

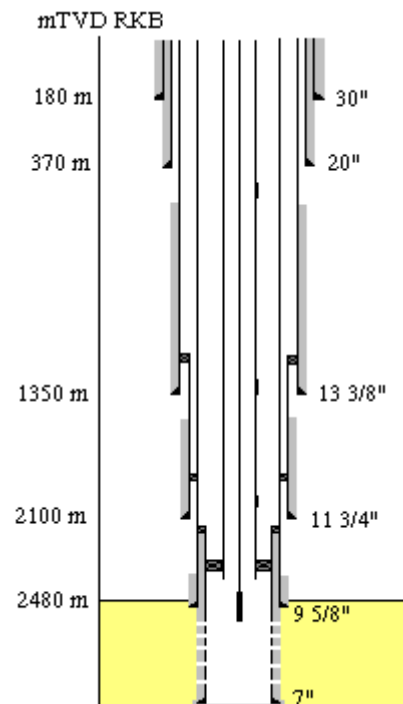

Figure 39: Well Diagnostics

These diagnostics are performed with wire line and coil tubing rigged up on Valhall DP. The operational goal for the campaign is to get down to the reservoir. If fill is encountered, this may be washed away with coil tubing in order to get further down. If it

is possible to reach the reservoir, the well will be killed. If a deformation is encountered that is not possible to get through, the depth will be tagged and it will be checked if it is possible to pump fluids through the deformation.

Doing well diagnostic in an early phase of the project has a lot of advantages such as;

- more knowledge about the well enables detailed planning of the P&A job
- it enables a safer and more cost efficient operation
- more effective use of an expensive jack-up rig

## **8.2 Rigless / rig work**

If it is possible to get sufficient communication down to the reservoir, the reservoir section will be killed and plugged rigless. If the well has a severe deformation which is not possible to pump liquids through, the killing of the well and the remaining P&A work will be done with a rig.

### **8.2.1 Kill well**

In order to proceed with the plug and abandonment operation, it is necessary to kill the well. To kill the well means to achieve hydrostatic overbalance in the well so that it stops flow from the reservoir to surface.

#### **8.2.1.1 Communication with reservoir:**

If there is communication with the reservoir, the well will be killed rigless by bullheading the tubing contents back into the reservoir and placing liquid in the well that exerts higher bottom hole pressure than the pore pressure in the reservoir or in the overburden in case of leaks. During this operation, there are some challenges that may cause problems. The reservoir may be fractured and lost circulation incidents may occur. It is therefore important to have lost circulation material (LCM) and kill fluid present on the rig. Once the well is killed with a stable overpressure, the Christmas tree (XMT) can be nipped down and the riser and blow out preventer (BOP) nipped up.

### **8.2.1.2 No communication with the reservoir:**

If there is no communication with the reservoir, it is not possible to bullhead the tubing contents back into the reservoir either. If the deformation in the well is below where the top of the secondary reservoir plug must be plugged, one can cut or perforate the tubing above the deformation, and circulate out wellbore contents with a heavier fluid that exerts higher pressure than the potential pore pressure from the reservoir and/or overburden. If the deformation is shallower than where the top of the secondary reservoir plug must be placed, collapse issues will have to be solved. Several options to solve the collapse issues are presented in chapter 7. If CT milling, CT abrasive technology or Extreme Expandacem is considered to be usable to re-open the collapse or to get through the collapsed section, it may be possible to solve the collapse issues rigless. If one of the other options, or a combination, is found to be necessary, the collapse issues will have to be solved with a heavy duty rig.

### **8.2.2 Plug reservoir**

If the reservoir shall be plugged or not is an ongoing discussion. If plugging is desired, the discussion is around how to best achieve an easy and qualitative plugging. Reservoir plugging of perforations within the reservoir is not necessary from a regulatory point of view. Only plugging of the top of the reservoir is required (i.e. putting a lid on the reservoir). Although plugging of reservoir perforations is not necessary, it might be desired from a reservoir management and oil recovery point of view. One of the concerns from the reservoir team is that injected water for pressure management can find a way from the injection well and into the perforations of a neighboring P&A - ed well. Then the least resistance for the water will be to follow the unplugged wellbore along its horizontal section. When the water reaches the base of the reservoir plug (normally at the heel of the well) it will leave the well at the top perforation. If this happens, it could ruin a planned water injection and water flooding strategy. For the wells that this is recognized as a viable threat, possible solutions may be to cement / use Sandaband throughout the entire reservoir section as shown in figure 40, or to seal off the reservoir section with several mechanical plugs. If such water breakthrough is not seen as a threat, it may still be a good solution to place a mechanical plug above the perforations to have a

good foundation for further P&A work. After the reservoir has been plugged, the tubing can be perforated. Then the tubing and annulus will be circulated with sea water and kill mud so that there is no hydrocarbons present in the well.

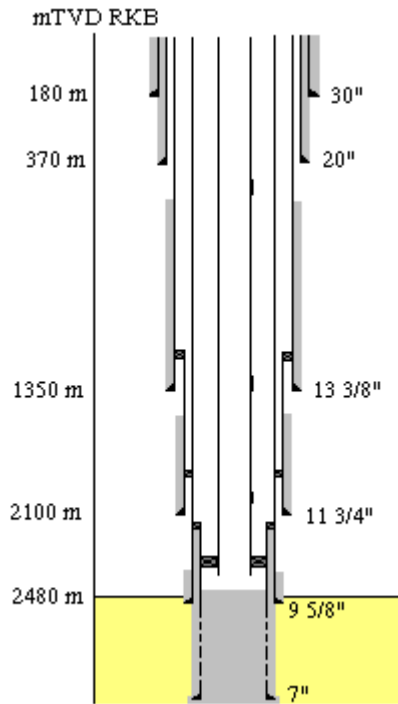

Figure 40: Cement plugged reservoir.

### 8.2.2.1 Sufficient accessibility:

As long as there is sufficient accessibility to run WL / CT into the well, it is possible to both seal off the reservoir with mechanical plugs and place cement / Sandaband through the reservoir without the use of a rig.

### 8.2.2.2 Insufficient accessibility:

If it is not possible to run wire line or coil tubing into the reservoir due to tubular deformations, it may be attempted to pump cement through the deformation and into the reservoir section. This method is quite uncertain due to several reasons;

- there must be communication with the reservoir,
- it is difficult to know exactly where the cement is,
- and there is a good chance that the cement will fracture the highly depleted reservoir at the top perforations and the cement will disappear into the formation.

If this method is seen inconvenient, collapse issues must be solved with the rig in order to plug the reservoir.

### 8.3 Rig work

#### 8.3.1 Pull tubing

In most of the wells there is control lines clamped to the tubing. In order to meet NORSOK requirements, these control lines cannot be present in the area where a well barrier plug shall be set. As described in section 3.4.4, there is to this date no technology that is able to remove these control lines without pulling the tubing. Tubing removal is considered a heavy operation that must be carried out by a rig due to lifting capacity.

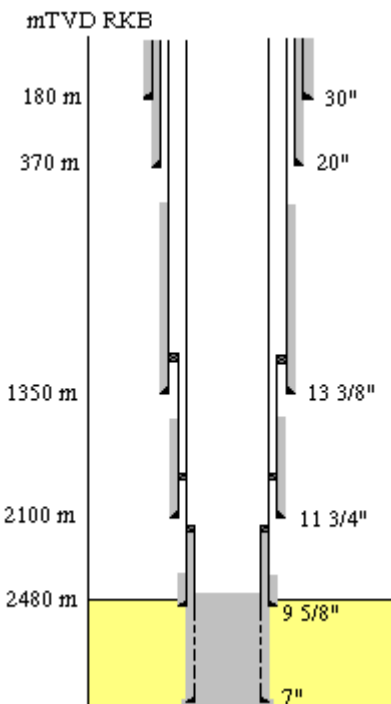

Figure 41: Pulled tubing

In most of the Valhall DP wells the tubing is attached to the reservoir liner in a polished bore receptacle (PBR). The tubing may be pulled out of the PBR by using a spear assembly at the wellhead. If it is not possible to pull the tubing out of the PBR, or the well has collapsed shallower than the PBR, the tubing will be cut as deep as possible and pulled out, removing the control line for the bottom hole gauge at the same time.

### 8.3.2 Reservoir abandonment

Both the primary and the secondary reservoir plugs above the reservoir shall be able to withstand any potential pressure from below (now or in the future). The minimum depth to the top of the secondary reservoir plug may be found with the procedure given in chapter 5. and appendix A. This depth shall be so deep that the formation outside the wellbore also has integrity high enough to withstand any potential pressure from below. With an estimated reservoir pressure of 6665 psia at 2664 mTVD RKB and oil as fluid between the reservoir and plug, the minimum depth to the top of the secondary reservoir plug is 2343,6 mTVD RKB.

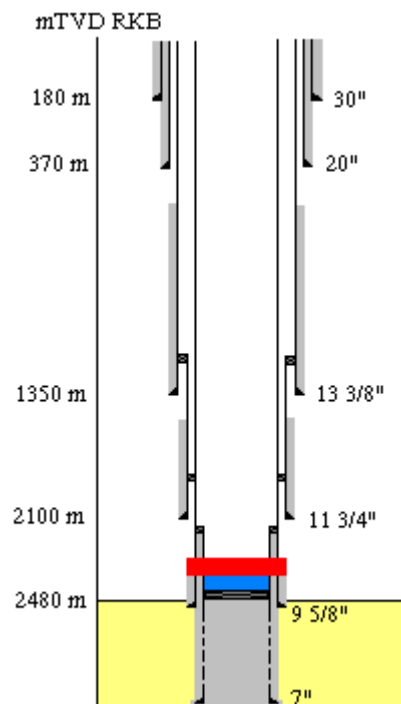

Figure 42: Reservoir abandonment

If there is insufficient annulus cement or insufficient information about the annulus cement at this depth, cement bond logging will be performed to verify annulus cement or annulus shale as a barrier. For annulus shale it will have to be verified that there are no hydraulic communication across the shale plug according to the procedure described in section 3.7.4. In order to meet the requirements from NORSOK and BP, there must be placed a primary and secondary well barrier. Both of these must seal the entire wellbore and all annuli.

### **8.3.2.1 Sufficient annulus barrier:**

If it by logging or with information from drilling of the well can be proven that there is a sufficient annulus barrier, a mechanical plug can be set as a foundation inside the wellbore. The mechanical plug will be set deep enough in the well so that the top of the secondary plug meet requirements for minimum setting depth according to chapter 5. Then primary and secondary well barrier plugs can be placed inside the casing / liner.

### **8.3.2.2 Insufficient annulus barrier:**

If it proves to be insufficient amount of annulus cement and annulus shale barrier may not be present, remedial actions will have to be taken. What kind of remedial action that has to be made is depending on the well design. If the well has an uncemented production casing as described in section 6.1.2, the Hydrawash system described in section 3.5.2. has proved other places to be a good solution. On the other hand, if the well design consists of an uncemented heavy wall overlapping liner as described in section 6.1.4, the challenge is much bigger. As of today, there does not exist a tool that is able to log the cement bond or presence of shale through several metal strings and annuli. Neither does there exist a tool that is able to perform remedial cementing through two metal strings. The technology that exists today is to section mill a window and place a well barrier plug in it. However, this will be very challenging both from operation and from HSE aspects. Once full cross sectional wellbore communication is achieved, well barrier plugs can be placed in the well, sealing the entire wellbore.

### **8.3.3 Overburden Abandonment**

As described in section 4, there are three zones in the overburden that must be plugged and abandoned with primary and secondary well barrier plugs (in addition to the reservoir plugs). These plugs shall seal the wellbore and all annuli in all directions. The zones are at the Gas Cloud at about 1430m TVD, the high pressure gas sand stinger at about 900m TVD and the shallow sand zone at about 450m TVD. In order to place competent well barrier plugs in the overburden, the 9 5/8" production casing must be cut and pulled out of the well. This has to be done because the 9 5/8" prod. casing is uncemented at the



relevant depths. In some wells, the 11 3/4" liner will also have to be cut and pulled in order to set competent gas cloud well barriers. The 13 3/8" intermediate casing is cemented in most Valhall DP wells, but both B and C annulus wellhead pressures are still present in several wells. This indicates that there is pressure communication through cement and casings, and a need for remedial annulus operations is required. The 13 3/8" casing will be logged and / or perforated and pressure tested in order to verify if an annulus barrier is present. If an annulus barrier is verified at relevant depths for the gas cloud and high pressure sand stinger, competent well barrier plugs will be set inside the casing on top of a mechanical plug. If the annulus barrier cannot be proven, the Hydrawash system could be used in order to perforate, wash and set competent well barrier plugs that seals off the wellbore and annuli.

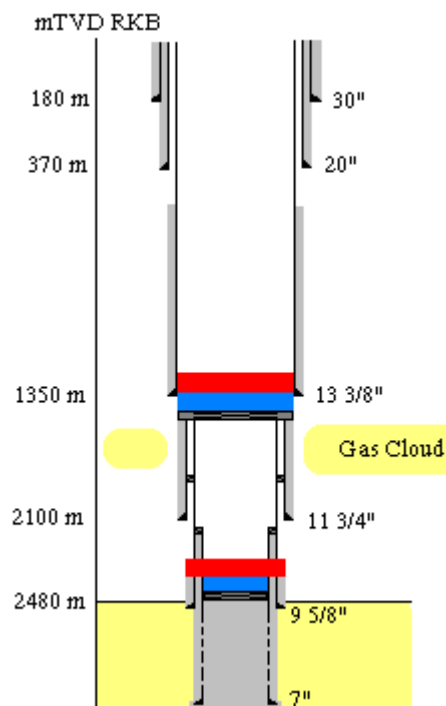

**Figure 43: Gas Cloud abandonment**

The shallow sand zone at about 450m TVD must be plugged at depths where there are both 13 3/8" intermediate casing and 20" surface casing. In most cases, the intermediate casing is uncemented at this depth, while the surface casing is cemented to surface. In order to plug the sand zone according to the requirements listed in section 3.2.3, the intermediate casing will have to be cut and pulled. In many wells at depths where the

well barrier plugs shall be placed, there is after casing cutting and pulling both a open hole section and a cased hole. The surface casing will be logged and/or pressure tested in order to verify annulus barrier. If a competent annulus barrier is proven, competent well barrier plugs will be set on top of a mechanical plug in the open hole and extended to the inside of the surface casing. If competent annulus barriers are not proven, the Hydrawash system can again be used to set good well barrier plugs where the surface casing is present.

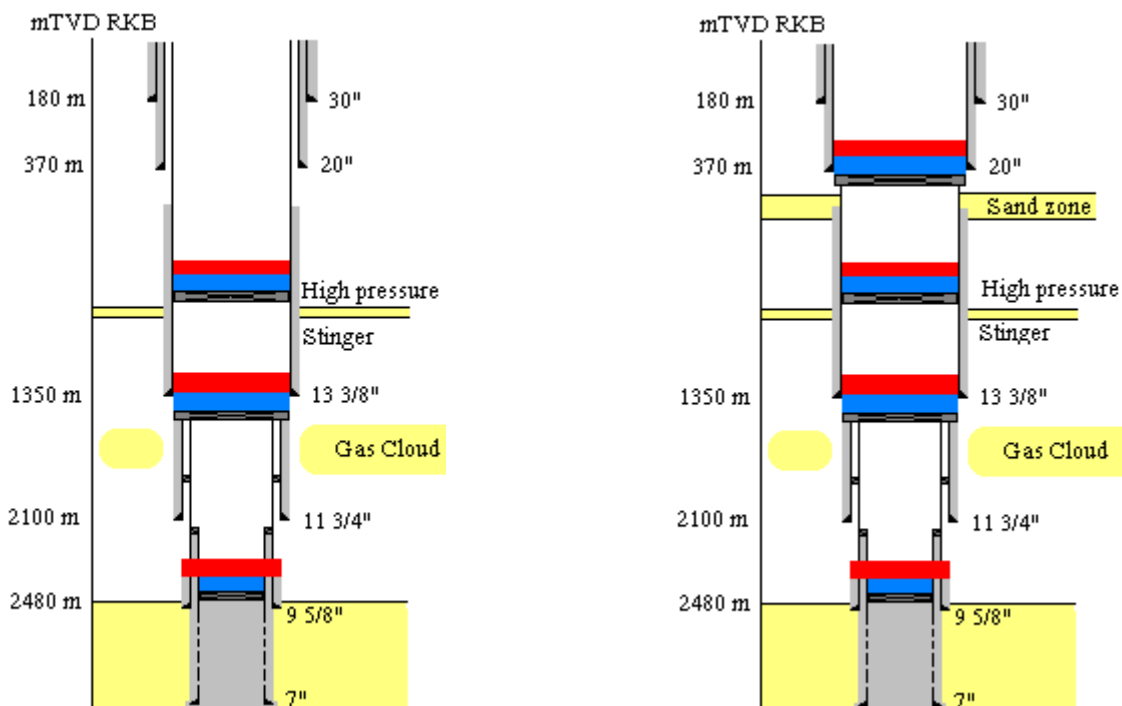

Figure 44: Plugging of the potential sources of inflow in the overburden.

### 8.3.4 Set surface plug

The surface plug is often referred to as “the environmental plug”. Its main purpose is to prevent swop out of mud with seawater due to sea currents. The surface plug will be set from the top of the secondary barrier above the sand zone at 450m TVD to approximately 5m from the seabed. This plug will be set inside the 20” surface casing. It is not necessary to verify the annulus barrier since the plug is not made to withstand any pressure potential.

## 8.4 Rigless work

### 8.4.1 Remove Multi string conductor

According to the requirements listed in section 3.2.3, the remaining casings must be cut 5 meters below seabed and removed together with the wellhead (as shown in figure 46 for a subsea well). After abandonment, the seabed shall appear untouched. The traditional way to do this has been to cut the conductor with knives, or in some cases explosives. In section 3.5.4, a quite new technology based on abrasive cutting is described. This technology has several advantages regarding HSE aspects, time consumption and costs. It is deployed from a ship or rigged up on the skid deck as will be the case for Valhall DP. The removal of the remaining casings / conductor on Valhall DP will be performed with this new technology.

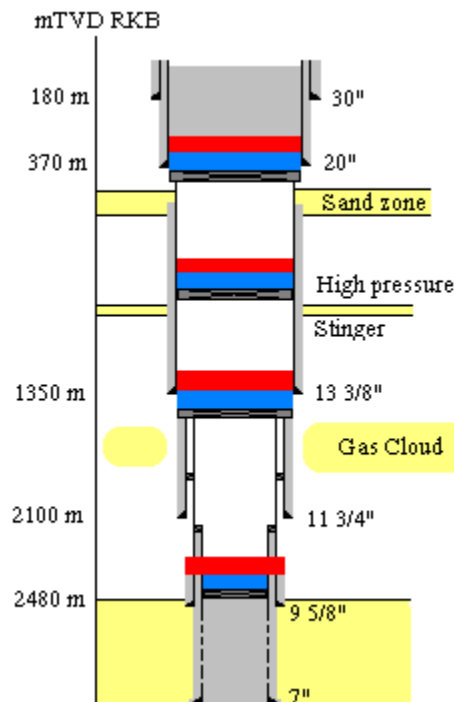

Figure 45: Completely P&A well.

This operation will be performed in a campaign after all of the 30 wells have been P&A-ed. In this way, if a leak should develop from one of the first P&A-ed wells while P&A-ing of one of the last wells, the conductor is still installed and enables re-entering into the already P&A-ed well which now is leaking. If the conductor already was removed, it

would be a lot more difficult to reconnect to the well at the seabed and re-enter the wellbore. When a well is completely P&A-ed it will look like the well in figure 45.



**Figure 46: Wellhead and multi string conductor removal.** [http://www.epmag.com/Production-Drilling/Decommissioning-Abandonment-Coordination-ensures-decommissioning-success\\_44547](http://www.epmag.com/Production-Drilling/Decommissioning-Abandonment-Coordination-ensures-decommissioning-success_44547)

#### **8.4.2 Platform removal [35], [39]**

After the Valhall DP wells have been P&A-ed, the platform itself must be removed. Normally the requirements are that the entire platform shall be removed and brought onshore. It is possible to get exemption for this if it may be proven that it is a better solution to leave the installation (or parts of it) offshore. The original Valhall Crest platforms; DP, QP and PCP will be brought to shore. There are several ways to do this:

- The installations may be re-floated and towed to an onshore decommissioning plant as seen in figure 47 (right).
- A lifting vessel may lift the installation in one or several lifts and load it onto barges that bring the structures to an onshore decommissioning plant as shown in figure 47 (left).
- In some cases it is also allowed to dispose the structures at deep waters.

**Single Lift**



**Float-up**

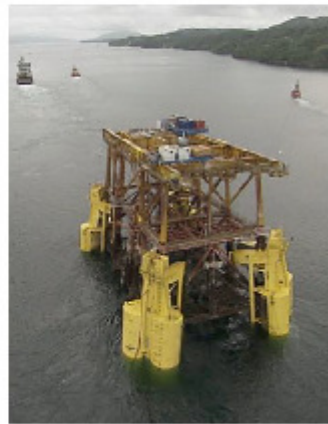

**Figure 47: Platform removal. [35]**

## 9 Rig options [39]

There used to be a drilling derrick on the Valhall DP platform, but due to high maintenance costs and a need for renewal of a lot of equipment, it was considered beneficial to remove it. Onshore, wells have been plugged and abandoned rig less for some years now using coil tubing [31]. These wells have been a lot less complex and without the same requirements with regards to control lines removal as for the Valhall DP wells. Most of the wells on Valhall DP have control lines attached, as explained earlier; the only way to remove the control lines with today's technology is to pull the tubing. This requires a heavy duty rig. Therefore, rig less plug and abandonment of the Valhall DP wells are seen as impossible with current technology.

Two alternative rig types have been analyzed for P&A of the Valhall DP wells; A Jack Up rig and a Modular rig as shown in figure 48. A jack up rig is a three (or four) legged drilling rig that is able to operate in water depths up to about 120 meters and can operate 100% independent. The derrick is cantilevered in over the platform. A modular drilling rig is installed on the deck of the platform itself, and must operate together with platform. This creates a more complex interface issue than with a self sufficient jack up. Below is a list of advantages and disadvantages of both alternatives:

Jack up rig:

- Expensive (300,000\$/day)
- + Experienced crew
- + Carries its own beds
- + More effective than a modular rig
- + Maersk Reacher is on a long term contract with BP Norway
- + 100% independent of existing infrastructure
- Must remove cuttings pile on seabed around Valhall DP?

Modular rig:

- + "Cheap" (120,000\$/day)
- Less effective than a jack up rig

- Availability, the only one that is operational according to NORSOK requirements is located in New Zealand.
- Does not carry its own beds
- Experienced crew
- Depending on existing infrastructure (such as mud pits, cement unit etc.)



**Figure 48: Maersk reacher. [www.ptil.no](http://www.ptil.no)**



**King 500. [www.kongshavn.no](http://www.kongshavn.no)**

The advantages and disadvantages of the Jack-up rig and Modular rig are discussed in section 10.5.

## 10 Discussion

### 10.1 P&A Regulations

In chapter 3, P&A regulations for Norway (NORSOK D-010), BP internally (BP GP 10-60) and Alaska (AOGCC) are presented. For P&A of the Valhall DP wells, it is the NORSOK D-010 requirements that are governing, unless BP's internal requirements create a stricter obligation and are in full compliance with NORSOK. The newest revision of the BP GP 10-60 standard is mainly based on the NORSOK and UKOOA (Great Britain) standards, but also well known API standards. NORSOK and BP internal requirements are in many ways quite similar. In some cases NORSOK is stricter, and in some cases are the BP internal requirements stricter. The biggest difference is that the BP requirements are a bit more descriptive than the more functional NORSOK standard. The descriptive character is more like the AOGCC requirements. The difference in a descriptive and a functional regime may have some consequences. One may argue that a functional regime is more encouraging for operators to find the best solution, enabling innovative technology and materials. An example can be that in the more descriptive BP requirements it is stated that cement shall be used for P&A well barrier elements, while the more functional NORSOK requirements states that the material used in P&A should have the following properties: Impermeable, long term integrity, etc...

Considering the descriptive regime, there is no reason for innovative service companies to develop new materials such as Sandaband, ThermaSet etc...

### 10.2 Technical Challenges

The weak Valhall chalk reservoir has caused a lot of technical challenges to the P&A of the Valhall DP wells. The technical challenges are directly related to the weak chalk reservoir in the form of collapsed wells. In order to prolong the lifetime of the Valhall production wells, challenging well design as the heavy wall liner overlap has been implemented.

As described in chapter 5, the minimum depth to the top of the secondary plug will be at about 2344m TVD RKB when oil is used as the fluid from the reservoir to the abandonment plugs. According to requirements in section 3.2.3, two well barrier plugs of



at least 50m MD and 30m TVD is needed. Since the reservoir is located at about 2450 m TVD RKB it is clear that the base of the primary well barrier plug must be placed more or less on the top of the reservoir.

In chapter 4, a review of the potential sources of inflow on the Valhall field is given. In the overburden there are three zones that must be P&A-ed. P&A of these overburden zones will be done after the reservoir is abandoned, and therefore collapse issues are already solved when the overburden is P&A-ed. There might be some challenges with regard to the well design at the depths where the overburden abandonment plugs shall be placed. For example, it will for several wells be necessary to cut and pull the 9 5/8" and 13 3/8" casings. However, there is well known technology for this challenge. In some wells it will be sufficient to use the Hydrawash system to set competent well barrier plugs in the annulus.

### **10.2.1 Collapse challenges**

As described in section 3.3.2, about one half of the Valhall DP wells may have experienced collapse. This number may change as well diagnostic is performed. Anyway, there are a quite large number of wells that may have to undergo some kind of operation in order to reach the top of the reservoir. Even if one knows that there is a collapse present, one does not know how long the collapsed section is. This will have impact with regards to which method will be chosen to get past the collapse, and the amount of time used.

Hydrocarbon exploration on the NCS did not start before the late 60's, and most of the big fields were developed in the late 70's and 80's. Most of these fields are still major producers on the NCS. It has therefore not been much focus on P&A of wells until recent years. Due to this, there is a technology gap that must be filled in order to P&A all wells according to NCS requirements. Since P&A has been performed world wide for decades, one would think that collapse challenges were present when P&A-ing wells at other locations as well. Collapsed wells are definitely an issue world wide, but the requirements are not the same world wide. In many other regions of the world, one can simply place well barrier plugs on top of the collapse. Due to this, much of the technology gap has to be developed in "our own backyard". In chapter 7, a short review

of different methods to solve collapse challenges are given. The casing / tubing opening tool, abrasive technology and expanding cement have never been used with the purpose of solving collapse issues. Using milling technology has been done before, and it is a well known fact that it is a time consuming, challenging operation with varying success. Sidetracking is a well known method as well, the challenge is to locate and re-enter the original wellbore below the collapse. This operation is also known to be quite expensive.

### **10.2.2 Well design challenges**

As shown in section 6.1.5 and appendix B, there are a total of 24 wells with heavy wall liner overlap. 12 of these are with cement in the annulus at the relevant depth, while the remaining 12 has insufficient amount of annulus cement. After a drilling liner started to be drilled and cemented, it has not been common practice to perform a cement bond log. There are therefore uncertainties about the reliability of the top of cement (TOC) and the bonding between formation - cement - liner, even for the wells that are considered to have annulus cement. The official TOC is most often estimated, based on returns during primary cementing. In some cases the primary cement job was unsuccessful and remedial cementing such as cementing through float collars and squeeze cementing were attempted. In these cases it is even more difficult to assess the TOC since one does not know where the cement goes. When planning P&A of these wells, the TOC and bonding between formation - cement - liner is information needed to be able to set competent well barrier plugs. In wells where there are not installed an overlapping heavy wall liner, it is possible to run a cement bond log after the tubing is removed. For the wells with an overlapping heavy wall liner this is not possible, as there is no tools present that are able to analyze the annulus behind two metal strings with cement in between. One way to verify annulus barriers where there is an overlapping heavy wall liner could be to perform a communication test as described in section 3.7.4. With this method, both annuli are verified.

Wells with overlapping heavy wall liner have been a great success by increasing the lifetime of the Valhall wells and thereby increasing production from the Valhall field. However, to plug and abandon some of these heavy wall liner overlap wells are very challenging due to the possible lack of annulus barrier. These challenges have already

been discussed in section 8.3.2.2. The main challenge is that in order to place competent well barrier plugs in these wells, one will have to create communication from the wellbore to the annulus. As of today, there is no technology designed to cope with this challenge. Section milling is considered to be the best alternative so far, but to mill through two liners, one of them 1.0" thick, with cement in between them is a challenging operation.

There are two wells that do not have an overlapping heavy wall liner and are believed to not have an annulus barrier at the reservoir plugging depth. These wells will be logged to verify if there is an annulus barrier or not. If there is not an annulus barrier, the Hydrawash system could be used to set competent well barrier plugs.

For wells that are known to have a competent annulus barrier, either from drilling information or from logging, competent well barrier plugs will be set inside the casing at the relevant depths.

### ***10.3 Innovative Technology***

As more and more oil and gas fields on the NCS mature, a large number of offshore wells have to be P&A. The combination of strict NCS requirements for P&A of oil and gas wells and the fact that many of the wells are old and designed for production, with less focus on P&A, creates a need for new technology. A lot of the traditional technology still being used is time consuming and has challenges regarding HSE aspects. There are therefore a great opportunities for innovative service companies to create revenues by inventing value adding products for the oil companies. The NOR-SOK D-010 requirements are based on a functional regime, allowing innovative solutions to challenge the more traditional ones. In order for new technology to be field proven, oil companies has a great responsibility in being courageous and willing to try out new technology. There has for a long time been reluctance from oil companies to be the first one to step out of their comfort zone and use new technology, even if it may bring large value adding cost efficiency. The last couple of years, there are several examples of new technologies that have added large amounts of value to courageous oil companies: ConocoPhillips saved an estimated 124 rig days on the first twenty wells they P&A-ed by using the Hydrawash system. BP has had great success using Sandaband to reduce sustained casing

pressure in collapsed wells. For P&A of the Valhall DP wells, BP has supported innovative service companies in order to commercialize technology needed to effectively solve some of the challenges present. At the same time as it is important to support and encourage new technologies, it is equally important to assess the different ideas and support the ideas one believe the most in and see the biggest need for. If not, one may end up using a lot of time and money on something that never was viable.

#### **10.4 Rig vs. Rig less**

To do P&A as cheap as possible without compromising quality is an overall goal for the entire petroleum industry. In order to achieve this, doing P&A rig less will be a major cost reducing contributor. In simple onshore wells, this has been possible for a long time [31]. On the NCS rig less P&A has not been possible so far due to several reasons such as:

- Pulling of tubing due to removal of control lines
- Section milling to create annulus communication
- CT facilities on LWI vessels to place cement plugs in subsea wells
- Heavy work equipment needed for solving collapse issues

In chapter 8, a general operational procedure is given, and it is explained how some operations can be performed rig less while others will have to be performed with a heavy duty rig. From the procedure given, it is clear that for the Valhall DP wells, the collapse issues and the combination of the well design and lack of annulus barriers are the governing parameters for how much work it is possible to do rig less. Pulling of tubing will have to be performed with a rig for all the wells.

If there are collapse issues, these may be solved rig less with abrasive technology or milling deployed on CT, but most likely one will bring in the heavy duty rig to have some more alternatives in case of something unwanted should occur.

If there is lacking annulus barrier in a well without overlapping heavy wall liner, it can be possible to place competent well barrier plugs with the Hydrawash system deployed on CT. On the other hand, if there is lacking annulus barrier in a well with overlapping

heavy wall liner, the only technology considered usable today is section milling deployed on drill string.

If the Valhall DP wells did not have all these issues with collapse and lack of annular well barriers, it could be possible to do the entire P&A operation rig less. The tubing could be pulled with a “pulling and jacking” unit placed on the deck of Valhall DP as shown in figure 49.



**Figure 49: Pulling and Jacking unit placed on deck of damaged platform. [41]**

These are common in the Gulf of Mexico (GOM), but haven't played any role on the NCS yet. As the NCS matures, and more and more permanent P&A will be done on the big fields, there might be a market for pulling and jacking units as well. The last couple of decades, more and more field developments are subsea developments. The NCA group and Island Offshore are collaborating on a venture called Subsea P&A which shall specialize in developing tools to do P&A of subsea wells rig less, using LWI vessels [42].

### ***10.5 Jack-up rig vs. Modular rig***

From the list of advantages and disadvantages in chapter 9, it is easy to see that the Jack-up has several large advantages compared to the modular rig. However the much lesser day rate of the modular rig can't be ignored. A modular rig will use more time than a Jack-up rig due to less operational efficiency. It is hard to tell how much extra time, since

there has not been performed much work on the NCS with a modular rig. Leading P&A engineers in BP have vaguely indicated that a modular rig may use as much as 25-40% more time than the jack up rig. This extra time must of course be added to the total cost picture.

The amount of time which will be used to P&A the Valhall DP wells does not only bring concerns around the total cost of the P&A operation. As described in section 3.3, the Valhall reservoir is compacting, which lead to seabed subsidence. The seabed subsidence has led to a too small air gap between the sea and the cellar deck on the platform, and waves could be hitting the cellar deck during winter storms. The more time that goes before the Valhall DP wells are P&A-ed and the platform removed, the higher the probability is that an unwanted event which could seriously damage the construction of the platform occurs. If this causes leakages from the wells to surface environment, it may have environmental impact also.

There is a lot of work ongoing on the Valhall field center. This creates problems with respect to the capacity of people being offshore at one time. If a modular rig is chosen to be rigged up on the skid deck on Valhall DP, an extra rig crew to do P&A is needed. As of today, there are not enough beds to do this. The jack up rig has a clear advantage since it carries its own beds, and will therefore make the logistics on the field center a lot easier.

Another aspect is the availability of the different rig types. The jack up rig Maersk Reacher is on a long term contract for BP Norway with an option of extending the contract. The issue is that this rig is mostly intended for drilling new production wells to increase the production from the Valhall field. Figure 50. clearly shows the value of having two drill strings in the ground drilling production wells, and hence the need for using Maersk Reacher for drilling new wells in addition to the Valhall IP rig. If another jack up rig will be hired to drill production wells while M. Reacher is doing P&A on Valhall DP, the rig rate for the new jack up may be even more expensive than the rate for M. Reacher, as the rig market is very tight these days.

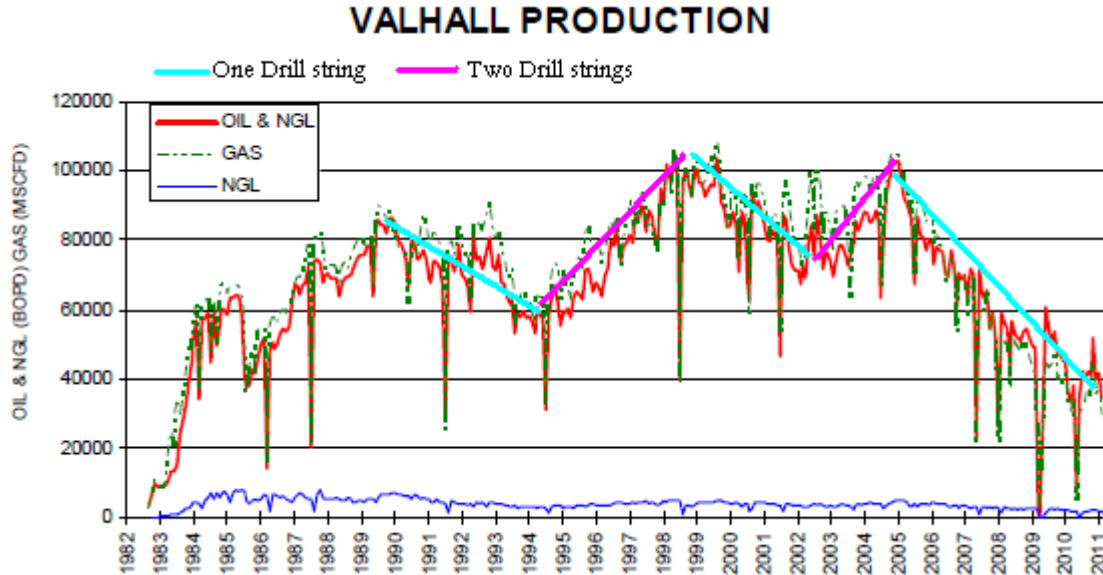

**Figure 50: Valhall production vs. number of drill strings. [Martin Straume]**

Modular rigs have not played an important role on the NCS for several years and there are no modular rigs on the NCS at the moment which complies fully with NORSOK standards.

Kongshavn AS constructed a modular rig called King 500 which was delivered to Odfjell Drilling in 1999. The King 500 operated on both Gullfaks B & C before Kavela bought the rig and brought it to Greece in 2004.

For several years now, this rig has been out of operation and the status of the rig is quite uncertain. Kongshavn does not have an operational rig crew, so if this rig should be used, an operational rig crew would have to be assembled through a drilling contractor.

The only operational modular rig that meets the NORSOK requirements today is Archer's rig, Emerald, currently being moved to New Zealand. It will start operation there in June 2012 with a contract period of 8 months and the option to stay until 2014. Archer is the owner and operator of the rig and it is anticipated their preferred option is to get new contracts in Oceania or Asia and establish a market there since the rig is already moved there. However, if someone strongly wants the rig, it is possible to move it. That is only a cost issue. To build a new Emerald rig according to NORSOK requirements will take about 22-24 months.

On the seabed below Valhall DP, there is a large cuttings pile from drilling the top holes without returns, and from dumping drill cuttings overboard while drilling wells in the

80's, which was the practice at that time. This cuttings pile will be a challenge when mobilizing a heavy duty jack up rig since the legs will have to be placed into the pile. The concern is that one of the legs will break through the pile in the middle of an operation and that this may have serious consequences. There is an ongoing conversation between the jack-up owner and BP around the technical implications of this. There is also an ongoing conversation with the Norwegian Klif (Climate and Pollution Agency) if this pile will have to be removed or not for environmental purposes when the DP steel jacket shall be removed some time in the future. If the pile will have to be removed, it will be a challenging and costly operation.

### **10.6 P&A Campaigns**

As described in chapter 8, P&A will be performed in campaigns to obtain synergy effects in several areas. The campaigns will be based on what type of rig that will be used. In chapter 8, the different operations that can be performed rig less or with rig are described. First, as much work as possible will be done rig less with wire line and coiled tubing on all the wells. Then, the heavy duty rig will do the work that it is needed on all the wells. At last the multi string conductor will be removed with abrasive cutting rigged up on the skid deck on Valhall DP. To do P&A in several campaigns has several advantages:

The different crews get familiar with the ongoing operations. The learning effect of having more or less the same crews on the rig for a long period, doing the same operations over and over again, enables safer and more efficient operations. I.e. the coiled tubing crew will be highly skilled in the operations they are doing when doing it for 30 wells in a row. If operations would not be performed in campaigns, but well by well, the coiled tubing crew would be there for about ten days. Then the CT crew would be changed out with the rig crew for about 30 days. The final operation would be for the abrasive cutting crew for maybe 5 days (the day estimates are nowhere close to being exact). Starting on a new well, the coiled tubing crew would come back and the circle would repeat itself. It is quite clear that this will be challenging with regards to logistics, and the crews will not be trained in the operations in the same ways as doing the operations in campaigns.



The learning effect has been documented by M.J Kaiser and R.D Dodson [43]. Based on data from over 1000 P&A-ed wells in the Gulf of Mexico, it is well documented that the unit cost per well decreases when the amount of wells that shall be P&A-ed increases. This learning effect can be transferred to P&A campaigns as well.

Another, very crucial aspect is that the heavy duty rig will have to be at Valhall DP all the time if the wells are not P&A-ed in campaigns. By doing P&A in campaigns, the heavy duty rig will only be at Valhall DP when it is needed, for the rest of the time it will drill new value adding production wells. The time used to change from wire line or coiled tubing to rig work would be minimized, which again leads to safer and more efficient operations.

The conductors will be removed in a conductor removal campaign after all the wells are P&A-ed. If there should develop a leak in one of the first P&A-ed wells while P&A-ing another well, the conductor is still attached and enables re-entering into the already P&A-ed wellbore. Re-entering the well would be a lot more difficult without the conductor being attached.

## 11 Conclusion and Recommendation

The original platforms on the Valhall field will have to be decommissioned due to integrity issues. The oldest drilling platform, Valhall DP, has 30 wells that must be P&A in order to remove the platform. These wells will be very challenging to P&A due to several reasons:

- Compaction in the reservoir has led to well collapse in the overburden
  - Reach minimum depth to set reservoir well barriers
- Heavy wall overlapping liner with lack of annulus barrier.
  - Well barrier plugs shall cover all possible leak paths, both in horizontal and vertical direction
- Technology gap
  - There is a lack of technology today to cope with some of the challenges present.

Norwegian and BP internal regulations are governing for P&A of the Valhall DP wells. Regulations for the minimum plug setting depth is governed by the internal BP GP 10-60 standard because that one is stricter than NORSOK at this point. The internal BP standard states that the well barrier plugs shall be placed so deep that the pressure from below does not fracture the formation on the top of the secondary plug (NORSOK uses the base of the secondary plug as minimum setting depth). Both the Norwegian and BP regulations state that well barrier plugs shall cover all possible leak paths, both in horizontal and vertical direction.

Wells with a collapsed section in the overburden, will have to be re-opened or sidetracked in order to reach sufficient barrier setting depth. A review of today's technology at this field has shown that there is a great need for innovative technology in order to solve this challenge in a safe and cost efficient manner. Several projects are on the way, but there is still a long way to go. If every effort has been tried without achieving communication with the wellbore below the collapsed section, it may be attempted to verify that the collapse is a barrier itself, and that plugging the well from the collapse and up is sufficient.

In some Valhall DP wells, there is limited information about the annulus barriers. In wells with a heavy wall liner overlap that are lacking annulus barrier, communication will have to be achieved between the wellbore and the annulus in order to place competent well barrier plugs. To get through the collapsed sections, one will have to invent new technology both to verify the annulus barrier and to place competent well barrier plugs in a safe and cost effective manner below the collapse.

In order for new technology to be developed and field proven, it is crucial that operating companies, such as BP, supports innovative service companies with both funding and implementation of new technology. The last decade has shown that there are great opportunities for increased revenues for innovative service companies and value adding cost efficiency for courageous operating companies, i.e. Hydrawell and NCA.

In addition to the reservoir, there have been identified three overburden zones that are considered potential sources of hydrocarbon inflow. These will also have to be plugged according to Norwegian and BP regulations. In some wells, some of these zones are lacking good enough annulus barriers as well. However, there does not exist overlapping liners at these depths. It will therefore be less complex to plug these zones using cost efficient technology such as the Hydrawash system.

An overall goal for the petroleum industry is to do P&A as cost efficient as possible without compromising the quality. In order to do this, completely rig less P&A is a goal that will greatly reduce the cost of P&A. The Valhall DP wells are considered too complex to be P&A-ed completely rig less in compliance with the Norwegian and BP internal regulations. Instead, the wells will be P&A-ed in campaigns based on what tools are needed. Doing P&A in campaigns makes it possible to do as much work as possible rig less, so that the heavy duty rig may focus on drilling new value adding production wells.

Different rig types have been evaluated. A modular rig could be placed on the skid deck of Valhall DP, while a jack-up rig can be positioned next to the platform and the derrick cantilevered over the wells. Due to the logistic complexity, less operational efficiency and availability of a modular rig, BP Norway has recommended the use of a jack-up rig to their partner Hess Norway, even though the rig rate is higher.

The last couple of years, Statoil have greatly influenced the design and number of new rigs on the NCS. As more and more of the big old oilfields on the NCS will have to be P&A-ed, it could be a good idea to develop specialized rig types for P&A, both for subsea wells and platform wells. These could be both cheaper and more suitable to do P&A. It would also increase the number of production wells drilled on the NCS since more rigs would be available for drilling of new wells in stead of doing P&A. In order to design as suitable rigs as possible for P&A, collaboration and sharing of experience between different operators drilling contractors is recommended.

Paying more attention to the fact that all wells shall be P&A-ed while designing and drilling new wells could possibly avoid some of the present challenges. For example: If the drilling liner was logged before the overlapping liner was installed, one could verify an annular barrier from day one. If an annular barrier was not verified, remedial work could be done right away. This could avoid the extra planning and costly work, and in that way lead to saving significant values when P&A-ing wells on a later stage.

To P&A a well could easily take as long time as drilling it, and it is 100% certain that there are more wells to P&A in the future than there are wells to be drilled. The people who will do most of the P&A on the NCS are still students or with a short professional career so far. At universities there are still a lot less focus on P&A of wells than drilling and completing new wells. Students within all well disciplines could have great benefits of better knowledge about P&A of wells. This could help changing some of the present focus (or lack of focus) in the industry on P&A when designing and drilling new wells, and also help solving some of the P&A challenges present today. In this way, significant

values could be saved for the operating companies and through taxes, the Norwegian society.

## 12 Reference

- [1] Olav Barkved, Pete Heavey, Roar Kjelstadli, SPE, Tore Kleppan, Tron G. Kristiansen, SPE, BP Norge Valhall field – Still on plateau after 20 years of production. SPE 83957. Presented at Offshore Europe 2003 held in Aberdeen, UK, 2-5 September 2003.
- [2] Valhall and Hod well history book, 2012
- [3] Karen E. Olson SPE and Evind Olsen SPE, BP Norway; Sami Haidar SPE Fracture Technologies; Alexandre Boulatsel SPE Schlumberger; Kristian Brekke SPE, PTI Valhall Field: Horizontal Well Stimulations “Acid vs. Proppant” and Best Practices for Fracture Optimization. SPE 84392. Presented at the SPE Annual technical conference and exhibition held in Denver, Colorado, USA 5 - 8 October 2003.
- [4] G. Tjetland, SPE, T.G. Kristiansen, SPE and K. Buer, BP Norway. Reservoir Management Aspects of Early Waterflood Response After 25 Years of Depletion in the Valhall Field. IPTC 11276. Presented at the International Petroleum Technology Conference held in Dubai, UAE, 4 - 6 December 2007
- [5] Valhall Waterflood – Executive summary April 2010. Prepared by Morten Hole
- [6] BP operated fields. The Valhall field  
<http://www.bp.com/extendedsectiongenericarticle.do?categoryId=9003524&contentId=7007324>
- [7] Norsk oljemuseum - Oljefelt - Valhall feltet  
[http://www.norskolje.museum.no/modules/module\\_123/proxy.asp?I=3178&C=266&D=2](http://www.norskolje.museum.no/modules/module_123/proxy.asp?I=3178&C=266&D=2)
- [8] Olje- og energidepartementet. St.prp. nr. 76 Utbygging og drift av Valhall videreutvikling.  
<http://www.regjeringen.no/nb/dep/oed/dok/regpubl/stprp/20062007/stprp-nr-76-2006-2007-2.html?id=468132>
- [9] bp internt, edition 8, 2011  
 Future Valhall Development
- [10] The Norwegian Petroleum act;. Act 29 November 1996 No. 72 relating to petroleum activities  
<http://www.npd.no/en/Regulations/Acts/Petroleum-activities-act/>
- [11] Petroleum Safety Authority of Norway [www.Ptil.no](http://www.Ptil.no) – About us
- [12] Petroleum Safety Authority of Norway [www.Ptil.no](http://www.Ptil.no) – Regulations
- [13] NORSOK Standard D-010 Rev, 3, August 2004
- [14] BP Group Practice 10-60 – Zonal Isolation, October 2011
- [15] Thomas E. Ferg and Hans-Jacob Lund, ConocoPhillips Norway, Dan Mueller, ConocoPhillips Houston, Morten Myhre, Arne Larsen and Patrick Andersen, Hydrawell Intervention, Gunnar Lende, Cato Prestegaard, David Field, Halliburton Norway, Charlie Hudson, MI Swaco Norge AS  
 Novel Approach to More Effective Plug and Abandonment Cementing Techniques. SPE 148640. Presented at the SPE Arctic and Extreme Environments Conference & Exhibition held in Moscow, Russia, 18 - 20. October 2011.

[16] Arild Saasen, SPE, Det norske oljeselskap ASA and the University of Stavanger; Sturla Wold, SPE, Bjørn Thore Ribesen, SPE, Tu Nhat Tran, SPE Det norske oljeselskap ASA; Arne Huse, SPE, AGR Petroleum AS; Vidar Rygg, SPE, Ingvar Grannes, SPE, and Alf Svindland, SPE, Sandaband Well Plugging AS

*Permanent Abandonment of a North Sea Well Using Unconsolidated Well Plugging Material. SPE 133446. Presented at the SPE Deepwater Drilling and Completion Conference held in Galveston, Texas, USA, 5 - 6. October 2010.*

[17] Eamonn Scanlon/ConocoPhillips, Garry Garfield/Baker Hughes, Siri Brobak/Baker Hughes  
*New Technologies to Enhance Performance of Section Milling Operations that Reduces Rig Time for P&A Campaign in Norway. SPE/IADC 140277. Presented at the SPE/IADC Drilling Conference held in Amsterdam, The Netherlands, 1 - 3 March 2011.*

[18] Fredrik Birkeland  
*Final Field Permanent Plug and Abandonment – Methodology Development, Time and Cost Estimation, Risk Evaluation - Master thesis 2011 University of Stavanger*

[19] Bengt Gunnarson  
*CannSeal Annular isolation on One single wireline run. Presented at the P&A workshop held in Sola, Norway 09.06.2011*

[20] AGR Group. CannSeal  
<http://www.agr.com/Our-Services/CannSeal/> (06.03.2012)

[21] Wellcem AS. ThermaSet  
<http://www.wellcem.no/thermaset-reg.html> (06.03.2012)

[22] Norse Cutting & Abandonment AS. Conductor and wellhead removal  
<http://www.nca-group.com/well-abandonment-services> (07.03.2012)

[23] Odd Inge Sørheim, Bjørn Thore Ribesen, SPE; Trond Eggen Sivertsen, SPE, Det Norske oljeselskap ASA; Arild Saasen, SPE, Det norske oljeselskap ASA and University of Stavanger; Øystein Kanestrøm, SPE, NCA Norway AS

*Abandonment of Offshore Exploration Wells using a Vessel Deployed System for Cutting and Retrieval of Wellheads. SPE 148859. Presented at the SPE Arctic and Extreme Environments Conference & Exhibition held in Moscow, Russia, 18 - 20. October 2011.*

[24] Tron Golder Kristiansen, Olav Barkved, BP Amoco Norge, and P. D. Patillo, BP Amoco UTG  
*Use of Passive Seismic Monitoring in Well and Casing Design in the Compacting and Subsiding Valhall Field, North Sea. SPE 65134. Presented at the SPE European Petroleum Conference held in Paris, France, 24 - 25 October 2000.*

[25] Tron Golder Kristiansen, SPE, BP and Bertold Plischke, SPE, ISAMGEO GmbH  
*History Matched Full Field Geomechanics Model of the Valhall Field Including Water Weakening and Re-Pressurisation. SPE 131505. Presented at the SPE EUROPEC/EAGE Annual Conference and Exhibition held in Barcelona, Spain, 14 - 17 June 2010*

[26] Stephen Williams, SPE, Truls Carlsen, SPE, and Kevin Constable, SPE, StatoilHydro ASA, and Arne Guldahl, SPE, Schlumberger

*Identification and Qualification of Shale Annular Barriers Using Wireline Logs During Plug and Abandonment Operations. SPE/IADC 119321. Presented at the SPE/IADC Drilling Conference and Exhibition held in Amsterdam, The Netherlands, 17 - 19 March 2009*

[27] Sondre Sandven

*Evaluation of a method of placing cross-sectional barriers during permanent plugging of wells - Master Thesis University of Stavanger 2010*

[28] BP Norway's overburden expertise, Tron G. Kristiansen, Chris Kent

*Valhall Overburden Evaluation. BP internal communication 10.11.2011*

[29] Wellbore AS, BP Norway - Study of collapse and re-expansion of tubing and liner. Project number: WB 10-851 CTO Project

[30] Wellbore AS - company visit 09.03.2012

*CTO tool presentation and workshop tour.*

[31] Frans Tettero, Ian Barclay - Petroleum Development Oman, Timo Staal - Schlumberger Oilfield Services

*Optimizing Integrated Rigless Plug and Abandonment - A 60 Well Case Study. SPE 89636. Presented at the SPE/ICoTA Coiled Tubing Conference and Exhibition held in Houston, Texas, USA, 23 - 24 March 2004.*

[32] AOGCC regulations - Alaska Oil and Gas Conservation Commission regulations

*Title 20, chapter 25. Section 1. Drilling and 2. Abandonment and Plugging*

[http://www.legis.state.ak.us/basis/folioproxy.asp?url=http://www.jnu01.legis.state.ak.us/cgi-bin/folioisa.dll/aac/query=\[JUMP:'Title20Chap25'\]/doc/{@1}?firsthit](http://www.legis.state.ak.us/basis/folioproxy.asp?url=http://www.jnu01.legis.state.ak.us/cgi-bin/folioisa.dll/aac/query=[JUMP:'Title20Chap25']/doc/{@1}?firsthit)

[33] InterAct - Investigative study for BP. Potential technologies for removal of downhole control lines & cables. 19. June 2009

[34] Well Integrity Engineer Daniel L. Tomczak

*Review of Valhall DP wells. 16.04.2012*

[35] Kjell Kåre Fjelde

*PP&A - Decommissioning field case. Lecture from "Advanced well technology" course.*

[36] Sondre Sandven

*Evaluation of a method of placing cross-sectional barriers during permanent plugging of wells*

*Master Thesis - UiS 2010*

[37] Halliburton cement products. - Expandacem

<http://www.halliburton.com/ps/Default.aspx?navid=169&pageid=5509&prodid=PRN%3a%3aJQOM31H>  
YP

[38] Eaton Oil Tools - Milling Tools

<http://www.eatonoiltools.com/ProductsAndServices/Milling-Tools>

[39] Lead P&A Engineer Martin Straume.



*Information gained through numerous conversations - Spring 2012*

*[40] Stijn De Jongh - Valhall Reservoir Teamleader*

*Valhall reservoir evaluation - BP internal communication 25.11.2009*

*[41] Offshore magazine. P&A Innovations increase efficiency, safety.*

*<http://www.offshore-mag.com/articles/print/volume-71/issue-2/production-operations/pa-innovations-increase-efficiency-safety.html>*

*[42] Solutions for Subsea Well Abandonment - Presentation to the Norwegian P&A Forum Workshop*

*June 2011 - Subsea P&A AS*

*[43] M. J Kaiser, R.D.D., Trends in plug and abandonment cost in the Gulf of Mexico, 2002-2007.*

*International Journal of Oil, Gas and Coal Technology, 2008. 1(Nos 1/2).*

**Appendix A. Minimum depth to top of secondary reservoir plug for Valhall DP wells**

Spreadsheet for calculating minimum depth to top of secondary reservoir plug

Reservoir data		
Maximum Reservoir Pressure	6665	Psi
Depth of Reservoir pressure	2664	mTVD RKB
Fluid data		
Gas gradient	0,33	Psi/m
Oil gradient	0,98	Psi/m
Sea Water gradient	1,42	Psi/m
Top of secondary plug		
Gas gradient	2424,1022	mTVD RKB
Oil gradient	2343,5751	mTVD RKB
Sea Water gradient	2251,6588	mTVD RKB

**Appendix B. Well Construction on Valhall DP wells**

Well Construction	W/ Annulus cement	W/O Annulus cement	W/cemented liner overlap, without annular cement	W/cemented liner overlap, with annular cement	Comment
Well					
2/8-A-1-A	X				Top of 5" Lnr Q-125 @ 2310mTVD. Top of 7" Lnr L-80 @ 1687mTVD. 9-5/8 csg window @ 1823 m TVD. TOC @ TOL with returns
2/8-A-2-B				X	Top of 5" Lnr Q-125 @ 2359mTVD. Top of 7" Lnr L-80 @ 1744mTVD. 9-5/8 csg window @ 1785mTVD. TOC estimated @ 2245mTVD
2/8-A-3-D T2			X		Top of 7" x 5 1/2" Lnr Q-125 @ 2278mTVD with TOC @ 2391 mTVD. 9 5/8" Lnr Q-125 shoe @ 2480 mTVD with TOC @ 2444 mTVD
2/8-A-4-B				X	Top of 6 5/8" Lnr Q-125 @ 2485mTVD. 9 5/8" C-95 csg shoe @ 2534mTVD with estimated TOC @ 2285mTVD
2/8-A-5-B				X	Top of 7 5/8" Lnr Q-125 @ 2344mTVD. Top of 7"x5 1/2" Lnr Q-125 @ 2335mTVD. 9 5/8" C-95 csg TOC estimated @ 1988 mTVD (90% losses)
2/8-A-6-A T4			X		Top of 5 1/2" Lnr Q-125 @ 2389 mTVD. 7 5/8 Lnr SS-95 TOC @ 2400 mTVD (acoustic log)
2/8-A-7-B T3				X	Top of 5 " Lnr Q-125 @ 2402 mTVD. 9 5/8" csg P-110 TOC estimated @ 2290 mTVD. 11 3/4" Lnr Q-125 TOC estimated @ 1996 mTVD (93% losses)
2/8-A-8-B					Well never reached reservoir. Shallower sources of inflow must be plugged according to regulations
2/8-A-9-A			X		Top of 5 1/2" Lnr Q-125 @ 2400 mTVD. Top of 7 5/8" Lnr Q-125 @ 1812 mTVD with TOC @ 2430 mTVD (Perforation squeeze)
2/8-A-10-B T3			X		Top of 7" x 5" scab Lnr P-110 @ 2036 mTVD with TOC to TOL. Top of 7" Lnr L-80 @ 2156 mTVD (uncemented). 9 5/8" csg Q-125 shoe @ 2512 mTVD and TOC estimated @ 2090 mTVD.

2/8-A-11-B T2			X		Top of 7" x 5 1/2" Lnr Q-125 @ 1868mTVD with estimated TOC @ 2260 mTVD. Top of 9 5/8" Lnr @ 1932 mTVD with estimated TOC @ 2450mTVD.
2/8-A-12-C			X		Top of 7" x 5 1/2" Lnr Q-125 @ 2178 mTVD with TOC @ TOL. Top 9 5/8" csg Q-125 @ 1921 mTVD with TOC @ 2462 mTVD (Tam collar)
2/8-A-13-C					Waste injection well into Late Oligocene @ 1886 mTVD
2/8-A-14-B T2				X	Top of 5" Lnr P-110 @2434 mTVD. Top of 7 5/8" Lnr Q-125 @ 1701 mTVD with TOC @ TOL (Returns).
2/8-A-15-A				X	Top of 5" Lnr L-80 @ 2350 mTVD. Top of 7" Lnr N-80 @ 2155 mTVD with TOC @ TOL (Returns). 9 5/8" csg C-95 window @ 2271 mTVD with BOC @ 1550 mTVD
2/8-A-16-E T3			X		Top of 7"x5 1/2" Lnr Q-125 @ 2292 mTVD with TOC @ TOL. Top of 9 5/8" Lnr Q-125 @ 2052 mTVD with TOC @ 2465 mTVD.
2/8-A-17 T2			X		Top of 7" Lnr L-80 @ 2225 mTVD with TOC @ TOL. 9 5/8" csg C-95 window @ 2306 mTVD with BOC @ 1352 mTVD
2/8-A-18-B			X		Top of Lnr 5" P-110 @ 2381 mTVD with TOC @ TOL. Top of 7" Lnr @ 1295 mTVD. Cement @ 7" Lnr shoe?
2/8-A-19-A T4			X		Top of 5 1/2" Lnr q-125 @ 2104 mTVD with TOC estimated @ 2260 mTVD. Top of 7 5/8" Lnr Q-125 @ 1684 mTVD with TOC estimated @ 2545 mTVD
2/8-A-20-(B&D)		X			B: Top of 5" Lnr Q-125 @ 2487 mTVD. Top of 7" Lnr Q-125 @ 1356 mTVD with TOC estimated @ 2565 mTVD D: Waste injection @ 2208 mTVD
2/8-A-21-A	X				Top of 7" Lnr L-80 @ 1940 mTVD with TOC @ TOL (returns)
2/8-A-22-A			X		Top of 5 1/2" Lnr Q-125 @ 1970 mTVD with TOC est. @ TOL. Top of 7 5/8" Lnr Q-125 @ 2120 mTVD with TOC est. @ 2555 mTVD. 9 5/8" Lnr shoe Q-125 @ 2177 mTVD W/O cmt.
2/8-A-23				X	Top of 7" Lnr L-80 @ 2397 mTVD. 9 5/8" csg shoe NT-95 @ 2499 mTVD with TOC est. @ 1384 mTVD.
2/8-A-24-A				X	Top of 5 " Lnr P-110 @ 2371 mTVD. 9 5/8" csg shoe C-95 @ 2477 mTVD with TOC est. @ 2258 mTVD.
2/8-A-25-B T3		X			Top of 6 5/8" Lnr Q-125 @ 2542 mTVD. 9 5/8" csg shoe C-95 @ 2608 mTVD with TOC est. @ 2430 mTVD.

2/8-A-26-A				X	Top of 6 5/8" lnr Q-125 @ 2443 mTVD. 9 5/8" csg shoe @ 2504 mTVD with est. TOC @ 2266 mTVD
2/8-A-27				X	Top of 5" lnr P-110 @ 2480 mTVD. 9 5/8" csg shoe @ 2534 mTVD with TOC @ 2315 mTVD (CBL).
2/8-A-28				X	Top of 5" lnr Q-125 @ 2491 mTVD. 9 5/8" csg shoe C-95 @ 2541 mTVD with est. TOC @ 2340 mTVD.
2/8-A-29			X		Top of 5" lnr Q-125 @ 2364 mTVD. 9 5/8" csg shoe C-95 @ 2534 mTVD with est. TOC @ 2425 mTVD. Top of 11 3/4" lnr Q-125 @ 1281 mTVD, shoe @ 2451 mTVD W/O cmt?
2/8-A-30-(A&B)				X	Top of 5" lnr Q-125 @ 2500 mTVD. 9 5/8" lnr shoe @ 2537 mTVD with est. TOC @ 2320 mTVD
Sum	2	2	12	12	

Appendix C. Operational procedure for Valhall DP well 2/8 - A - XX

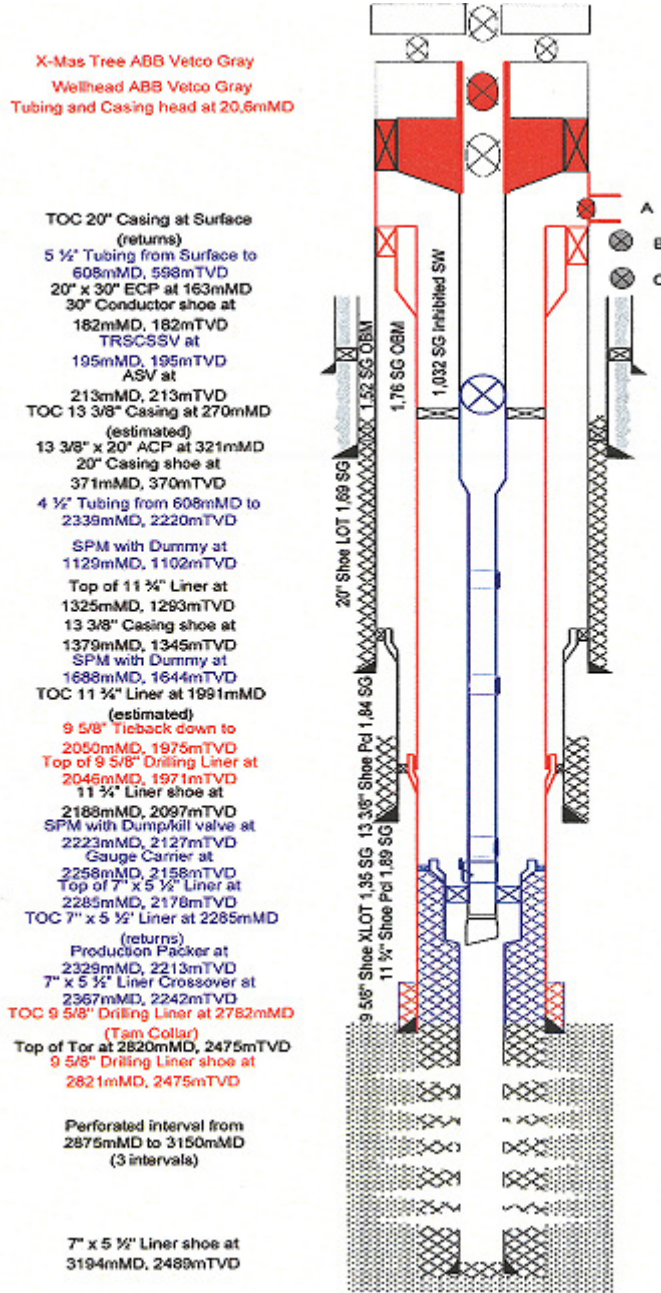

Figure 51: Well barrier schematic. 2/8 - A - XX [BP internal]

	<b>2/8 - A - XX</b>
	<b>Well Design</b>
	<b>Well with heavy wall liner overlap, without annular cement, with reservoir communication</b>
	<b>Operational procedure</b>
	<b><u>Rigless work</u></b>
	<b>Well diagnostic and kill well</b>
1	Rig up coil tubing as required
2	Top up tubing with inhibited seawater and bullhead tubing contents back into reservoir.
3	Drift run to hold up depth, include memory pressure and temp gauges for inflate bridge plug setting data gathering. Need to access depth top TOR formation. POOH
4	RIH with bridge plug and set in liner at Top of Tor formation (but below tailpipe) or as deep as possible. Test plug to 1000 psi over seawater
5	RIH and perforate the tubing just above the packer. POOH.
6	Circulate tubing and annulus contents to inhibited seawater, or kill brine or WBM
7	R/D Coil Tubing
8	Monitor tubing and annulus pressure for 0 psi
	<b><u>Rig work</u></b>
	<b>Rig preparations</b>
9	Skid rig over slot and secure (assumed jack up rig)
10	Rig up wireline set & test (2500psi) retrievable mechanical plug below hanger in 5 1/2" tubing.
11	Nipple down Xmas tree.
12	Nipple up riser and BOPs. Pressure test.
13	Rig up wireline.
14	RIH and remove wire line plug below hanger.
15	Establish circulation and circulate 2-3 times to remove any remaining hydrocarbons from tubing and A annulus. Confirm plug integrity at the same time
	<b>Recover production tubing</b>
	<b>(If a collapse is present, this issue will have to be solved before the tubing is recovered)</b>
16	RIH spear or tubing hanger pulling tool and latch hanger
17	Pick up tubing weight plus over-pull to un-seat the production packer. Allow packer element to relax
18	Recover tubing (based on 6 joint per hour) - check for LSA
	<i>Contingency:</i> If unable to pull tubing, run severance shot to cut tubing as deep as possible.

	<b>Establish annulus communication</b>
	<b>(As of today, section milling is the only alternative)</b>
19	RIH casing milling tool to mill overlapping production liner
20	Mill 2 x 50m at top of Tor.
21	Do cleanout run to recover all milling swarf.
22	RIH section milling tool to mill drilling liner
23	Section mill 2 x 50m at top of Tor
24	Do cleanout run to recover all milling swarf.
	<b>Primary Reservoir Barrier</b>
25	RIH 2 7/8" cement stinger. Length of cement stinger dictated by height of proposed cement plug
26	Run in hole with drill pipe to just above the bridge plug at Top of Tor
27	Pump chemical wash ahead of cement volume as advised by cementing engineer.
28	Place primary plug
29	Pull cementing string 200 m above TOC of the plug, circulate stinger and drill pipe clean.
30	WOC, then RIH to tag TOC.
	<b>Secondary reservoir barrier</b>
31	RIH 2 7/8" cement stinger. Length of cement stinger dictated by height of proposed cement plug
32	Run in hole with drill pipe to just above primary plug
33	Pump chemical wash ahead of cement volume as advised by cementing engineer.
34	Place secondary plug on top of primary plug, and set plug to inside 9 5/8" casing
35	Pull cementing string 200 m above TOC of the plug, circulate stinger and drill pipe clean.
36	WOC, then RIH to tag TOC.
37	POOH with cementing stinger
	<b>Cut &amp; Recover 9 5/8" Casing</b>
38	Check and bleed down any pressure in the B annulus (if unable to bleed down may need to weight up mud system prior to cutting casing)
39	RIH casing cutter, cut 9 5/8" casing at circa 1400 m MD.
40	P/U casing spear, engage in 9 5/8", confirm free, circulate out old OBM from B annulus.
41	POOH, lay out cutting assembly
42	Continue POOH with 9 5/8" casing
	<b>Log 13 3/8" annulus barrier</b>
43	Rig up WL



44	RIH wire line SBT/CBL log to 11 3/4" liner hanger
45	Log from Liner hanger to seabed
46	Rig down WL
	<b>Primary Gas Cloud Barrier (Annulus barrier outside 13 3/8" csg assumed verified)</b>
47	RIH 100 m 2 7/8" or 3 1/2" cement stinger complete with cement retainer.
48	Run in hole with drill pipe to 11 3/4" liner hanger.
49	Set cement retainer unsting then pressure test to 0.1 psi /ft above LOT at this depth.
50	Unsting from retainer. Pump chemical wash ahead of cement volume as advised by cementing engineer
51	Place primary plug from retainer depth.
52	Pull cementing string 200 m above TOC of the plug, circulate stinger and drill pipe clean.
53	WOC, then RIH to tag TOC.
	<b>Secondary Gas Cloud Barrier (Annulus barrier assumed verified)</b>
54	Pump chemical wash ahead of cement volume.
55	Place secondary plug on top of primary plug.
56	Pull cementing string 200 m above TOC of the plug, circulate stinger and drill pipe clean.
57	WOC, then RIH to tag TOC.
58	POOH with cementing string
	<b>Primary High pressure stinger Barrier (Annulus barrier assumed verified)</b>
59	RIH 100 m 2 7/8" or 3 1/2" cement stinger complete with cement retainer.
60	Run in hole with drill pipe to the top of the high pressure stinger at about 900m TVD.
61	Set cement retainer unsting then pressure test to 0.1 psi /ft above LOT at this depth.
62	Unsting from retainer. Pump chemical wash ahead of cement volume as advised by cementing engineer
63	Mix cement then place plug from retainer depth.
64	Pull cementing string 200 m above TOC of the plug, circulate stinger and drill pipe clean.
65	WOC, then RIH to tag TOC.
	<b>Secondary High pressure stinger Barrier (Annulus barrier assumed verified)</b>
66	Pump chemical wash ahead of cement volume.
67	Place secondary plug on top of primary plug
68	Pull cementing string 200 m above TOC of the plug, circulate stinger and drill pipe clean.
69	WOC, then RIH to tag TOC.
70	POOH with cementing string

	<b>Primary Sand Zone Barrier (Annulus barrier assumed verified)</b>
71	RIH 100 m 2 7/8" or 3 1/2" cement stinger complete with cement retainer.
72	Run in hole with drill pipe to the top of the sand zone at about 430m TVD.
73	Set cement retainer unsting then pressure test to 0.1 psi /ft above LOT at this depth.
74	Unsting from retainer. Pump chemical wash ahead of cement volume as advised by cementing engineer
75	Mix cement then place plug from retainer depth.
76	Pull cementing string 200 m above TOC of the plug, circulate stinger and drill pipe clean.
	<b>Secondary Sand Zone Barrier (Annulus barrier assumed verified)</b>
77	Pump chemical wash ahead of cement volume.
78	Place secondary plug.
79	Pull cementing string 200 m above TOC of the plug, circulate stinger and drill pipe clean.
80	WOC, then RIH to tag TOC.
81	POOH with cementing string
82	RIH wireline to perforate the 13 3/8" casing Circa 260 m MD
83	Circulate the 13 3/8 x 20" annulus to remove OBM.
84	Nipple down BOPS
	<b>Cut &amp; Recover 13 3/8" Casing</b>
85	RIH casing cutter, cut 13 3/8" casing at circa 250 m MD.
86	P/U casing spear, engage in 13 3/8", confirm free.
87	POOH, lay out cutting assembly
88	Continue to POOH with 13 3/8" casing
	<b>Set surface plug</b>
89	Pump chemical wash ahead of cement volume.
90	Place surface plug.
91	Pull cementing string 200 m above TOC of the plug, circulate stinger and drill pipe clean.
92	WOC, then RIH to tag TOC.
	<b>Rigless work</b>
	<b>Wellhead and multistring conductor removal</b>
93	Nipple down Wellhead
94	Rig up NCA conductor removal equipment on skid deck
95	RIH abrasive cutting tool to 5m below seabed
96	Perform abrasive cutting of multistring conductor
97	Pull multistring conductor with conductor jack pinning and securing each 10m section before cutting it with a conductor saw

	<b>End of Abandonment</b>
--	---------------------------