



Faculty of Science and Technology

MASTER'S THESIS

Study program/ Specialization: Offshore Technology/Subsea and Marine technology	Spring semester, 2014 Open / Restricted access
Writer: Aleksandr Yurevich Boiko	 (Writer's signature)
Faculty supervisor: Ove Tobias Gudmestad External supervisor(s): Anatoly Borisovich Zolotukhin	
Thesis title: Offshore Ice-resistant Fixed Platform for the Dolginskoye field in the Pechora Sea	
Credits (ECTS): 30	
Key words: Ice loads, Gravity Based Structures, Arctic conditions, Fixed Platforms, Caisson, Monocone structure, Multi-column structure	Pages:92..... + enclosure:11..... Stavanger, ...15.06.2014..... Date/year

OFFSHORE ICE-RESISTANT FIXED PLATFORM FOR THE DOLGINSKOYE FIELD IN THE PECHORA SEA

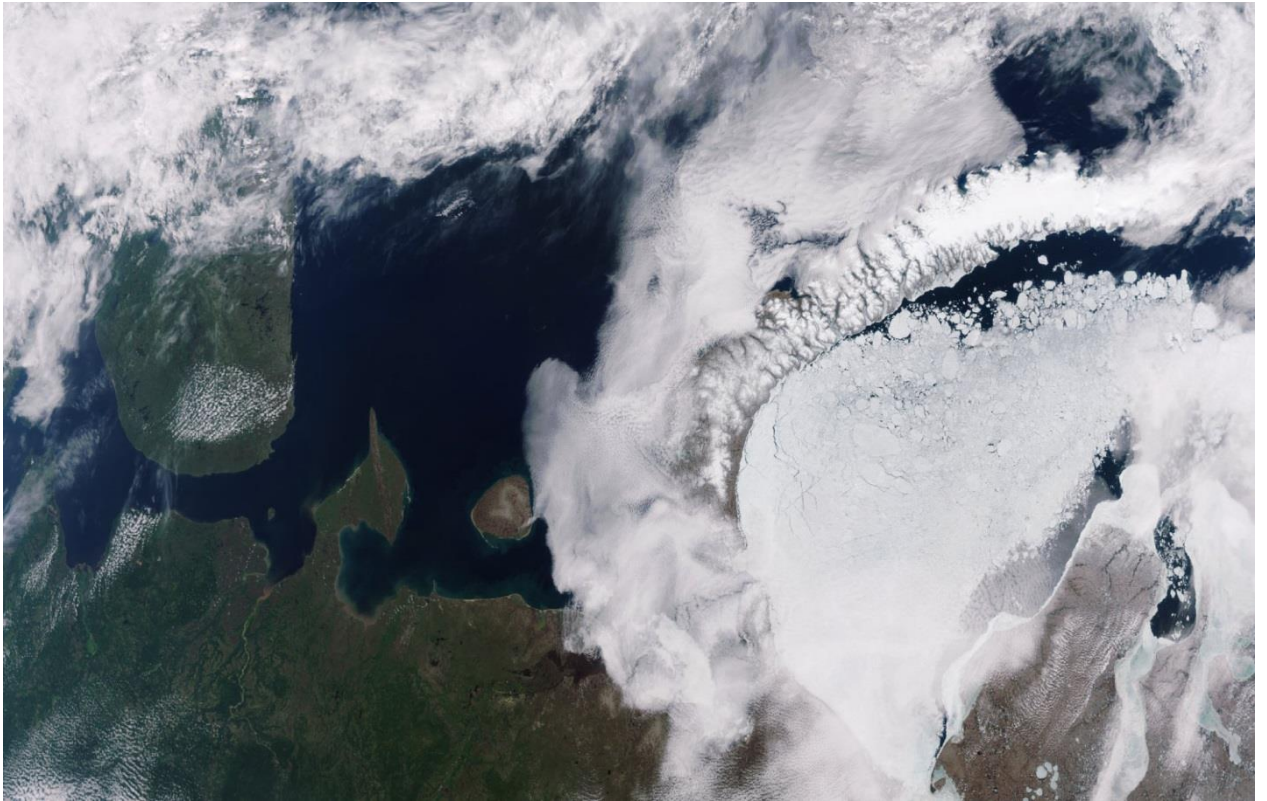

WRITTEN BY ALEKSANDR YUREVICH BOIKO

UNIVERSITY OF STAVANGER
GUBKIN RUSSIAN STATE UNIVERSITY OF OIL AND GAS

TABLE OF CONTENTS

1. ABSTRACT	4
2. ACKNOWLEDGEMENTS.....	5
3. LIST OF ABBREVIATIONS	6
4. LIST OF FIGURES.....	7
5. LIST OF TABLES.....	9
6. INTRODUCTION	10
7. PROJECT DEVELOPMENT.....	11
8. GEOGRAPHY AND RECOURSES OF THE PECHORA SEA.....	14
9. ENVIRONMENTAL CONDITIONS OF THE PECHORA SEA	17
9.1. MAIN PARAMETERS	18
9.2. METOCEAN DATA	18
9.3. SOIL CONDITIONS	20
9.4. ICE CONDITIONS.....	22
10. FIELD GEOLOGY	29
11. ICE LOADS ON FIXED STRUCTURES.....	32
11.1. ICE ACTIONS.....	33
11.2. ICE LOADS ON VERTICAL STRUCTURES.....	36
11.3. ICE LOADS ON STRUCTURES WITH SLOPING WALLS.....	37
11.4. ICE RUBBLE LOADS.....	38
11.5. ICE RIDGE LOADS.....	39
12. FIELD DEVELOPMENT	42
12.1. EXISTING EXPERIENCE	43
12.2. ICE-RESISTANT GBS DESIGN PRINCIPLES.....	45
12.3. FIELD DEVELOPMENT SCENARIOS.....	46
12.4. SUBSEA TEMPLATES	48
12.5. OFFLOADING SCENARIOS.....	52
12.6. SUPPORT VESSELS.....	53
13. DESIGN OF THE PLATFORMS.....	55
13.1. EXISTING EXPERIENCE	56
13.2. METOCEAN DATA	57
13.3. POSSIBLE CONCEPTS	59
13.4. TOPSIDE.....	62
13.5. OIL STORAGE SYSTEM	63
13.6. OFFLOADING SYSTEM.....	64
13.7. CONSTRUCTION AND INSTALLATION.....	65
13.8. EXPLOITATION PROBLEMS.....	70
14. ECONOMIC ANALYSIS	75
15. RISK ANALYSIS	82
16. CONCLUSIONS AND REMARKS.....	89
17. REFERENCES	90
18. LIST OF APPENDICES.....	93

1. ABSTRACT

Oil and Gas fields on the Russian Arctic Shelf are very difficult to develop as there is a lack of relevant experience around the world. Existing technical solutions should be improved and adjusted to the specific environment.

Selection of an appropriate offshore facility design mainly depends on environmental conditions, in which the facility will be applied. The factors that have to be taken into consideration are: water depth, strength of the soil foundation, local and global ice forces, metocean and geographic conditions, etc. In addition, facilities and equipment have to be optimized in accordance with a number of criteria such as process design, safety, storage and supply capacity, access to construction materials, minimum capital/operational expenditures and so on.

The master thesis will describe the concept for an Ice-resistant Fixed Production Platform that can successfully operate at the Dolginskoye field in the Pechora Sea. Because of the shallow water, the harsh ice conditions and the functional requirements a Gravity Based Structure (GBS) of the caisson-retained type will be suggested as the most efficient solution. Other GBS types are also considered for comparison.

The existing experience of facilities currently installed in the Pechora Sea and other Arctic areas is taken into consideration for designing the concept. Technological features of the Prirazlomnaya OIRFP (Offshore Ice-resistant Fixed Platform) and the Varandey Oil Terminal are discussed in the work.

In order to estimate all possible loads acting on the structure, its shape, size and material issues will be carefully analyzed. These parameters also influence transport and installation operations, weight and layout of topside equipment, storage capacity, and, therefore, the field development scenario.

Finally, the thesis will present a conceptual model and calculations, which are needed to estimate on-bottom stability and the ice-breaking capability of the structure.

2. ACKNOWLEDGEMENTS

I would like to thank professors of UiS for their help and the useful material given to me during the Autumn semester 2013.



3. LIST OF ABBREVIATIONS

CAD - Computer-Aided Design

CAPEX – Capital Expenditures

EER – Emergency, Evacuation and Rescue

FEED - Front-End Engineering and Design

GBS - Gravity Based Structure

ISO - International Standards Organization

MTOE – Million Tonnes of Oil Equivalent

OPEX – Operational Expenditures

OGB – Oil and Gas Basins

OIRFP – Offshore Ice-resistant Fixed Platform

MVL – Mean Water Level

GPN – Gazprom Neft

LLC – Limited Liability Company

4. LIST OF FIGURES

- Figure 1 - Classification of Offshore facilities for the tasks of CAD
- Figure 2 – Life phases of Oil and Gas field development project
- Figure 3 – Oil and Gas Resources of the Pechora Sea
- Figure 4 – Map of bottom sediments of the Pechora Sea (2012)
- Figure 5 – Ice concentration, maximum/minimum ice extent in the Pechora Sea (March 2012). Bathymetry of the Pechora Sea
- Figure 6 – Testing the ice cores in the portable compression rig “KOMPIS” (left) and recording the data (right)
- Figure 7 – Vertical and horizontal strength of ice vs. temperature
- Figure 8 - Vertical and horizontal strength of ice vs. salinity
- Figure 9 – Geological map of the Dolginskoye field
- Figure 10 - Probability of failure determined from load and resistance distributions
- Figure 11 - Global ice actions on vertical structures
- Figure 12 – Forming grounded ice rubble in front of platform
- Figure 13 – Scheme of ice ridge configuration
- Figure 14 – Well pattern at the Prirazlomnoye field
- Figure 15 – Development layout of the Statfjord field
- Figure 16 – Development scenarios of the Dolginskoye field (images made in Questor 10.1. The types of the structures used in the Figure show only that the concepts for platforms are GBSs, the bigger one is the host platform, the smaller one is a wellhead platform. A detailed description of the concepts is presented in the next chapter)
- Figure 17 – 4-well manifold template
- Figure 18 – First offloading scenario (to shuttle tankers)
- Figure 19 – Shuttle tanker “Mikhail Uljanov” used for transportation of oil from the Prirazlomnaya field
- Figure 20 – Ice-breaker used at the Prirazlomnoye field
- Figure 21 – Concepts for GBSs for the Dolginskoye oil field: monocone (one-column) GBS (left) and multi-column GBS (right)
- Figure 22 – Design of columns for the Dolginskoye field platforms (presented concept has been designed for bridges over rivers; in order to implement it at offshore platforms much wider base is necessary to resist loads)
- Figure 23 – Hull geometry for the caisson-type structures at 50 m water depth
- Figure 24 – Configuration of topside for multi-column platform
- Figure 25 – Configuration of the Prirazlomnaya platform
- Figure 26 – Storage tanks of the Prirazlomnaya platform
- Figure 27 – Offloading system at the Prirazlomnaya platform
- Figure 28 – Configuration of the Prirazlomnaya platform walls
- Figure 29 - Construction and installation of OIRFPs for Sakhalin projects
- Figure 30 – Rock berm packing method
- Figure 31 – Satellite picture of wake at the Prirazlomnaya platform (left) and offloading operation (right)
- Figure 32 – Effect from different geometries of the platform’s hull
- Figure 33 – Ice rubbles in front of the platform
- Figure 34 – Ice accumulation scenario for different hull shapes
- Figure 35 – Effect of ice on structures with upward/downward cone angle

Figure 36 – Initial data for cost estimate (Questor 10.1)

Figure 37 - Cost estimate in different phases of the project development

Figure 38 – Possible annual production profiles

Figure 39 – Possible project schedule

Figure 40 – Risk matrix

Figure 41 – Potential oil pollution of the seawaters and the shoreline after oil spill of 10000 t over 5 days

Figure 42 – Vessels currently exploiting in the Pechora Sea

Figure 43 – Bow-tie diagram

Figure A.1.1 – Total horizontal ice loads onto the GBS with different slope angles

Figure A.1.2 – Horizontal ice load for different slope angles due to adfreezing

5. LIST OF TABLES

Table 1 - Typical environmental conditions of the Pechora Sea

Table 2 - Sea ice conditions in the Sveasunda fjord

Table 3 – Resources of the Dolginskoye field

Table 4 – Classification of ice actions

Table 5 – Structural form elements and ice/element interaction

Table 6 - Dolginskoye field development characteristics

Table 7 – Gathering and Distribution system elements

Table 8 – Elements of the 4-well template

Table 9 – Offshore GBS or pile-type structures for shallow waters and terms of their application

Table 10 – Establishing a new dry dock site preparation

Table 11 – Infrastructure and equipment for fabrication concrete structures

Table 12 – Accuracy of cost estimate

Table 13 – HAZOP analysis

Table 14 – Classification of probabilities of hazardous events

Table 15 – Classification of consequences of hazardous events

Table A.1.1 – Extreme environmental conditions of the Pechora Sea chosen for calculations

Table A.1.2 – Total horizontal ice loads onto the GBS with different slope angles

Table A.2.1 – Ice ridge load on the structure estimated by different methods

Table A.6.1 - Cost evaluation of the Dolginskoye project

Table A.6.2 - Offshore cost summary for the Dolginskoye field

6. INTRODUCTION

Nowadays, there is a big potential for Arctic offshore field developments. However, the drilling and production facilities should be designed to withstand huge environmental loads and protect the personnel and the surrounding nature from such harsh conditions.

The Arctic field development presents a lot of challenges as the following¹:

- ✓ Severe climate conditions
- ✓ Presence of ice
- ✓ High cost
- ✓ Long distance export of oil and gas – additional heavy cost
- ✓ Lack of technology, competence and experience in offshore field development
- ✓ Deficit of qualified personnel
- ✓ Environmental risks, not yet fully understood
- ✓ Emergency response time

With an increase of experience gained from the currently operated offshore facilities future structure designs are subjected to some modification and modernization. Severe environment, like in the Arctic, is promoting usage of the most sophisticated technology and the most creative solutions, especially for the oil and gas field development.

Typically, many concepts for field development are proposed and only the most profitable and suitable ones will have a real potential to be chosen. Thus, every project has to meet a lot of requirements in order to be realized and every decision should be carefully analyzed before it's made.

Selection of an appropriate design mainly depends on the working conditions and the loads it will be exposed to during structure and equipment exploitation. These are water depth, strength of the soil foundation, local and global ice forces, metocean and geographic conditions, etc. In addition, facilities and equipment have to be optimized in accordance with a number of criteria such as process design, safety, storage and supply capacity, access to construction materials, minimum capital/operational expenditures and so on.

Therefore, it's very important to estimate all possible environmental loads. A part of the project is focused on the description of ice loads and different scenarios for ice-structure interaction. Every structure should be well protected from possible damage caused by ice.

The feasibility of Arctic oil and gas resource development is strongly dependent on existence of the strict standards that ensure the capability of the installed structures and the systems to withstand harsh environmental Arctic conditions, especially ice features relevant to the certain region². The main Arctic standard, ISO 19906 Arctic Offshore Structures, will be described in the work.

¹ Zolotukhin A.B. 2012. Fundamentals of Petroleum Geology, Reservoir and Production Engineering. Lecture for the course "Offshore Field Development Technology". Gubkin Russian State University of Oil and Gas, Moscow

² Ghoneim G.A., Veritas D.N. 2011. Arctic Standards – A Comparison and Gap Study. Arctic Technology Conference, Houston, Texas, USA. OTC 22039

7. PROJECT DEVELOPMENT



For shallow Arctic waters the application of OIRFP is usually considered. As you can see in Figure 1, our objective is to consider possible OIRFP designs that can be implemented at the Dolginskoye field.

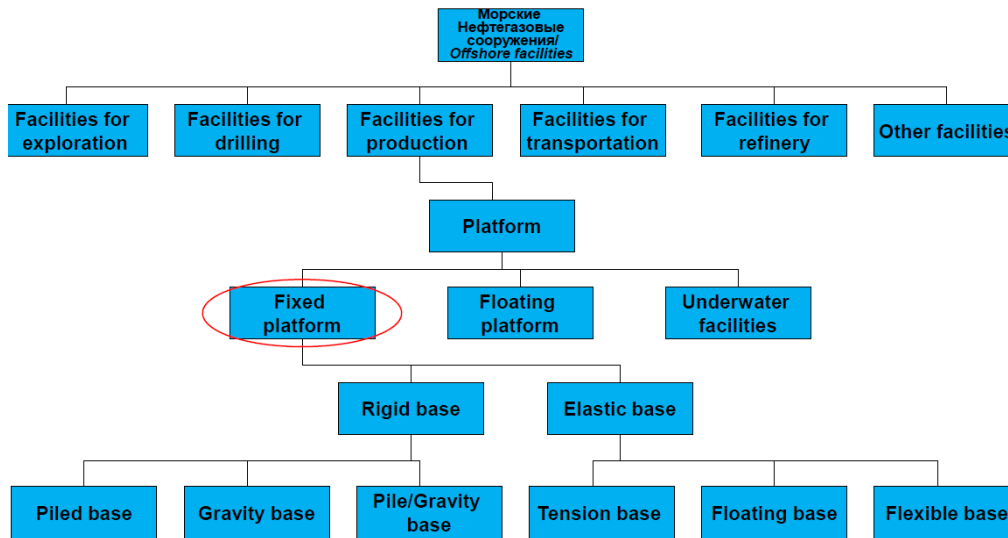

Figure 1 - Classification of Offshore facilities for the tasks of CAD³

In general, Oil and Gas Field development project consists of several phases which are presented in Figure 2.

Exploration is the first phase that is undertaken by a contractor of the project. The duration of the phase can last for several years depending on the complexity of the explored site. Since the Dolginskoye field is located in the Arctic area with harsh ice conditions, the period of its exploration estimated to be long. A decision on the next phase depends on the results of exploration. If the exploration is successful meaning a discovery of a field with proven reserves (commercially recoverable under current economic conditions) the project development can be continued.

The next phase is the Field Development. A part of this phase is Project Evaluation Studies, during which the best field development scenario has to be chosen. It will allow us to minimize the project costs and possible risks. Evaluation Studies comprise the following stages:

- Preliminary
- Conceptual
- Pre-project or Pre-FEED
- FEED

³ Ermakov A.I. 2012. Course "Challenges of Offshore project development". Lecture #2 "Offshore Facilities and Techniques". Gubkin Russian State University of oil and gas

The first one is initial evaluation of preliminary development scenario, feasibility of the project and its economic potential. Appraisal works are also defined at this stage.

During Conceptual studies a comparable analysis of various development scenarios is performed and the most profitable and least risky concept is chosen for the further consideration. The technical feasibility of the chosen concept should be confirmed at this stage.

The next one, Pre-project or Pre-FEED phase, considers technical aspects of the project, field development plan performing cost estimation, project scheduling and execution principles.

An investment decision on the field development is made before the next stage.

In case of positive decision the company and contractors perform basic engineering proceeding to construction of facilities and commissioning stage, which are also included in the Field Development phase.

A cost of the project mainly depends on the Conceptual stage as you choose the concept with less CAPEX and OPEX in combination with low risk. Moving to next phases the project is becoming more defined and detailed that provides further cost saving. Better work on the concept will allow to significantly reduce the expenditures during the Field Operation phase.

First of all the comparative analysis based on economics and risk analysis. The risk analysis is provided for every considered concept to determine the least risky ones. Then, those projects that have less cost and low risk can proceed to the further stages. Approximate budget of the Arctic offshore project is estimated from several billions to more than ten billion dollars.

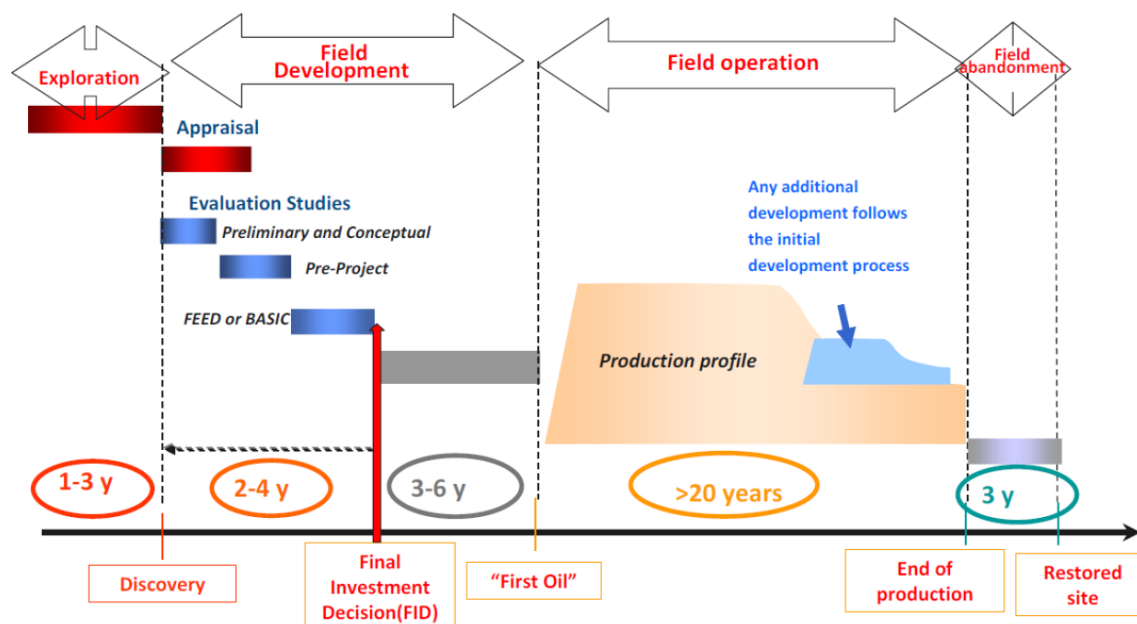
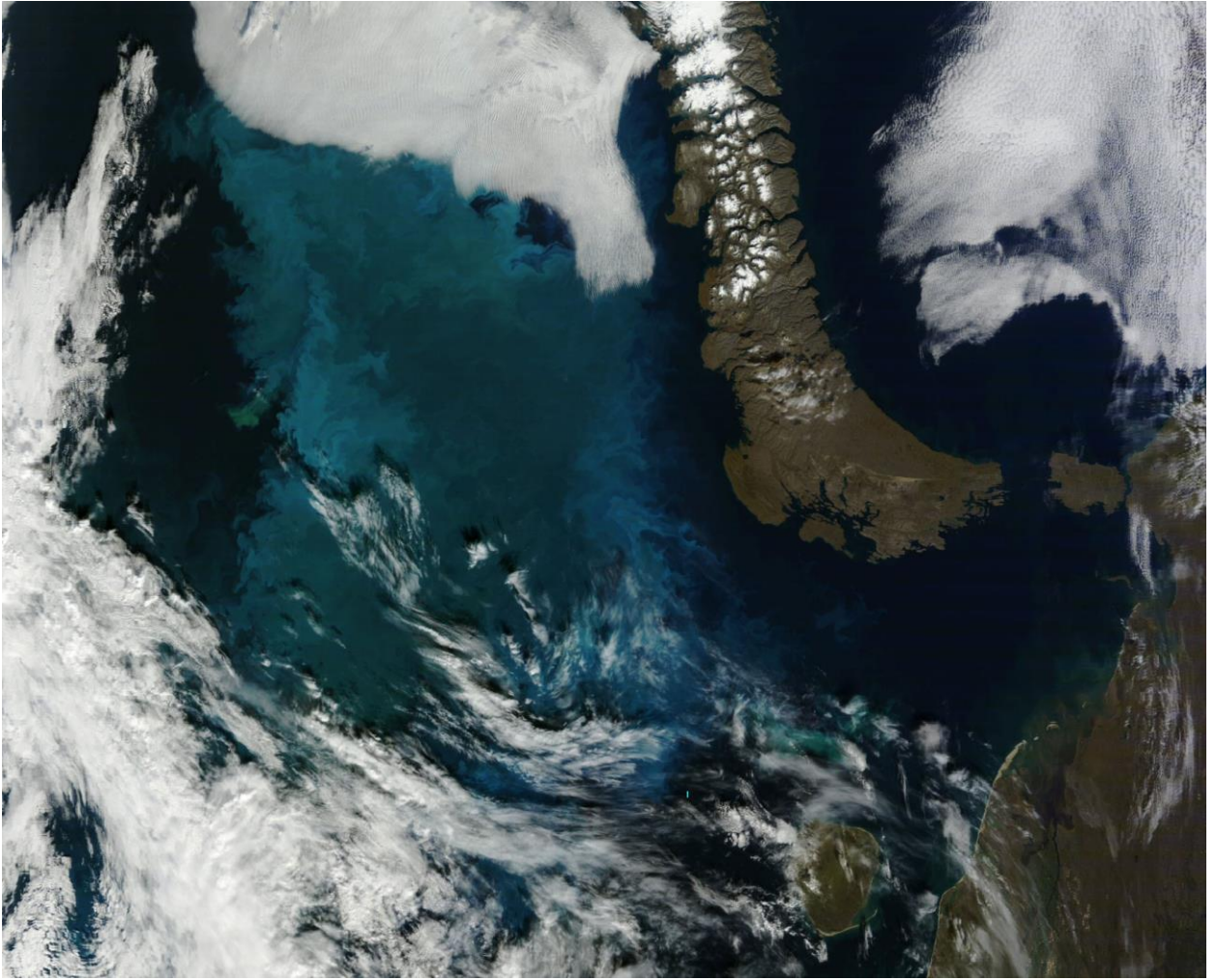

Figure 2 – Life phases of Oil and Gas field development project³

8. GEOGRAPHY AND RESOURCES OF THE PECHORA SEA



The Pechora Sea (Russian name - Pechorskoye More) is a southeastern extension of the Barents Sea located in the European part of Russia. It is laid between Kolguyev Island to the west and the Yugorsky Peninsula to the east, while its northern border is Novaya Zemlya.

The length of the Sea is about 300 km from West to East and 180 km from North to South having the surface area of approximately 81 000 km² and the overall water volume of 4380 km³.

The Sea is shallow since its average water depth is around 6 m, but it gradually increases toward the North reaching the maximum depth of 210 m. The eastward-flowing Kolguyev Current and its extension, the Novaya Zemlya, flow in the southern part of the Sea, where the Sea is fed by its main river, the Pechora River⁴.

There are a lot of oil and gas fields across the Timan-Pechora Basin and most of them have not been developed yet. Many fields have been discovered in sedimentary cover of various ages. The reservoirs are divided into two categories: riftal and post-riftal. The reservoirs which are belonging to the first category have been found in Ordovician, Devonian, Silurian and Frasnian layers. Those belonged to the second category are laid in Upper Devonian, Tournaisian, Carboiferous (Visean), Permian and Triassic layers.

However, their development is a big challenge due to severe environment. Polar lows, strong winds, waves and currents accompanied with ice drift, ridges and icebergs could create huge loads on structures, which are aimed to develop the fields. Moreover, the sea depth variations lead to different structure design. For instance, an application of Gravity Based Structures (GBS) in the Arctic is limited by approximately 100 meters depth, while floating or subsea units have much higher limits, but they cannot be used in shallow water due to inefficient operability and higher costs comparing to GBS⁵.

The Dolginskoye oil field is located in the northern part of the Timan-Pechora Basin, in the latitude of 70 °N and longitude between 56 and 57 °E, 120 km north of the Russian mainland and 110 km south of Novaya Zemlya. The field was discovered in 1999. The water depth in the field location varies from 20-25 m in South-East part to 40-45 m in North-West part. The first part has flat bench-like surface, while the second is slightly sloped in North-West direction⁶.

Figure 3 shows the location of the Dolginskoye field and Petroleum Resources of the Pechora Sea.

⁴ The seas of the World. The Pechora Sea (Russia). Available from: <http://inpath.ru/nature/sea/263>. (read 20.02.2014). Моря мира. Печорское море (Россия)

⁵ The course of lectures organized by Total Professors Associates. 2013. Arctic design. Offshore structures and ships. Northern (Arctic) Federal University named after M.V. Lomonosov

⁶ Novikov A.Y. 2014. Studies of stability of the drilling unit "Arcticheskaya" on the soil of Dolginskoye license sector. Explanatory note 130401.65.Д14.544.ВКР.ПЗ. Новиков А. Ю. 2014. Исследование устойчивости установки на грунте самоподъёмной буровой установки "Арктическая" на Долгинском лицензионном участке. Пояснительная записка 130401.65.Д14.544.ВКР.ПЗ



Figure 3 – Oil and Gas Resources of the Pechora Sea⁷

⁷ Arctic Europe Petroleum Resources and Infrastructure. Available from: <http://www.arctic-europe.com/>. (read 15.02.2014)

9. ENVIRONMENTAL CONDITIONS OF THE PECHORA SEA



3.1. MAIN PARAMETERS

In this report, the data was taken from two sources for comparison. The first one is dated by 1999⁸. The typical environment of the Pechora Sea taken from the first source is given in Table 1.

Table 1 - Typical environmental conditions of the Pechora Sea⁸

Parameter	Pechora sea conditions
Latitude	70 °N
Max. wind gust, m/s	41
Min. air temp., °C	-48
Sign. wave height, m	6,2 (at 45 m water depth)
Currents velocity, m/s	1
Freezing up (average)	Nov. (Oct.) – Eastern part of the Sea
Clearing (average)	June
Average open water, days	110
Multi-year ice, %	-
Max. level ice thickness, m	1,3
Rafted ice thickness, m	2,6 (twice level ice thickness)
First-year ridge thickness, m	12-18
Multi-year ridge thickness, m	-

3.2. METOCEAN DATA

The metocean data and statistics of Pechora Sea conditions have been recorded since early forties by several meteorological stations.

Wind and air temperature

Wind conditions in the Pechora Sea are season dependent. According to the first source⁸ the prevailing wind direction in winter season is South-West. Summer season has unstable wind conditions and North of North-West prevailing direction. The 50-year wind speed can reach its extreme value of 26 m/s with the duration of 6-7 hours. However, among the other Arctic seas the wind conditions in the Pechora Sea is mildest.

An air temperature is below 0 °C for 230 days per year. A mean value in February which is the coldest month is about -18,3 °C and the maximum value that was recorded at Varandey is approximately -48. The annual mean temperature is in a range between -2,9 and -5,6 °C depending on the location.

The data about metocean conditions in the area of the Dolginskoye field was taken from a data source dated by 2014⁶.

⁸ Gudmestad O.T., Zolotukhin A.B., Ermakov A.I., Jakobsen R.A., Michtchenko I.T., Vovk V.S., Loeset S., Shkhinek K.N. 1999. Basics of Offshore Petroleum Engineering and Development of Marine Facilities with Emphasis on the Arctic Offshore. Stavanger/Moscow/St. Petersburg/Trondheim. Publishing house "Oil and Gas", 1999

In the summer season a mean value of wind speed is about 6 m/s. During a storm, in the same season the speed can reach 20 m/s with duration of 6 hours in average and 36 hours at maximum. Even 30 m/s is possible with the maximum duration of 6 hours.

Air temperature in the region varies from -46 °C in January to +26 °C in July-August. During the year the monthly average air temperature fluctuates from -17,4 °C in February to +6,5 °C in July, while the annual average value is about -5,1 °C.

Sea level, waves and currents

As was mentioned above, the water depth in the field location varies from 20-25 m in South-West part to 40-45 m in North-West part.

Wave conditions in the Pechora Sea are influenced by presence of north, east and south shorelines which protect the area from significant waves, and small water depths⁸. However, such waves come from North-West, sometimes reaching the value of 11,5 m at regions with 20-30 m water depths during the storm season running in October-November. The mean height is approximately 2-3 m. In summer season the waves are usually not more than 3-4 m. An average wave length doesn't vary significantly in all Arctic Seas and doesn't exceed 150-180 m.

The maximum level amplitude in the eastern Pechora Sea with return period of 50 years is $\pm 1,25$ for circular tide and $\pm 3,25$ for no periodic storm surge.

In the sea there are three main currents: Kalin, Kolguev and Litke. Their velocity is approximately 0,02-0,05 m/s. Current parameters vary from region to region influencing metocean and ice conditions in every region. In general, tide currents flow from South-East to North-West direction, and vice versa during ebb tides. The spring tide current velocity is up to 0,4 m/s, while wind ebb-tide currents can have 1 m/s at maximum. 100-year return period velocity of the currents is 0,6-0,65 m/s.

In the region of the Dolginskoye field average parameters of 10-100 year wave in the region are the following⁶:

- wave height – 3,2-4,7 m;
- wave length – 110-154 m;
- wave period – 8,6-10,5 s.

Water level fluctuations in the region are governed by tides, storms and ice conditions. Their maximum amplitude is up to 3,4-3,8 m. Half day (semidiurnal) tidal fluctuations are governed by astronomic effects and can reach the maximum value of 1,2 m. Storm surge fluctuations of a long return period (50 years) are up to 2,6 m.

Temporary changes of summarized currents are caused by tides, wind, ice conditions, thermohaline water circulation and ice conditions in the area of the field. Maximum values of current local velocity recorded in September-October 1991 and July 1997 are 0,5-0,6 m/s (mean value across the water column). The values recorded in June-July 2007 are 0,6-1,5 m/s at 0-10 m water depth and 0,3 m/s near the sea bottom.

3.3. SOIL CONDITIONS

Figure 4 represents the map of soft and hard sea bottom sediments. The large part of the Pechora Sea and the coastal area of the Novaya Zemlya, which are mainly shallow, have soft bottom sediments with sandy-gravelly mud (diamicton). But, in the area of the Dolginskoye field the sea bottom sediments are classified as hard sediments consisting of sand or muddy sand.

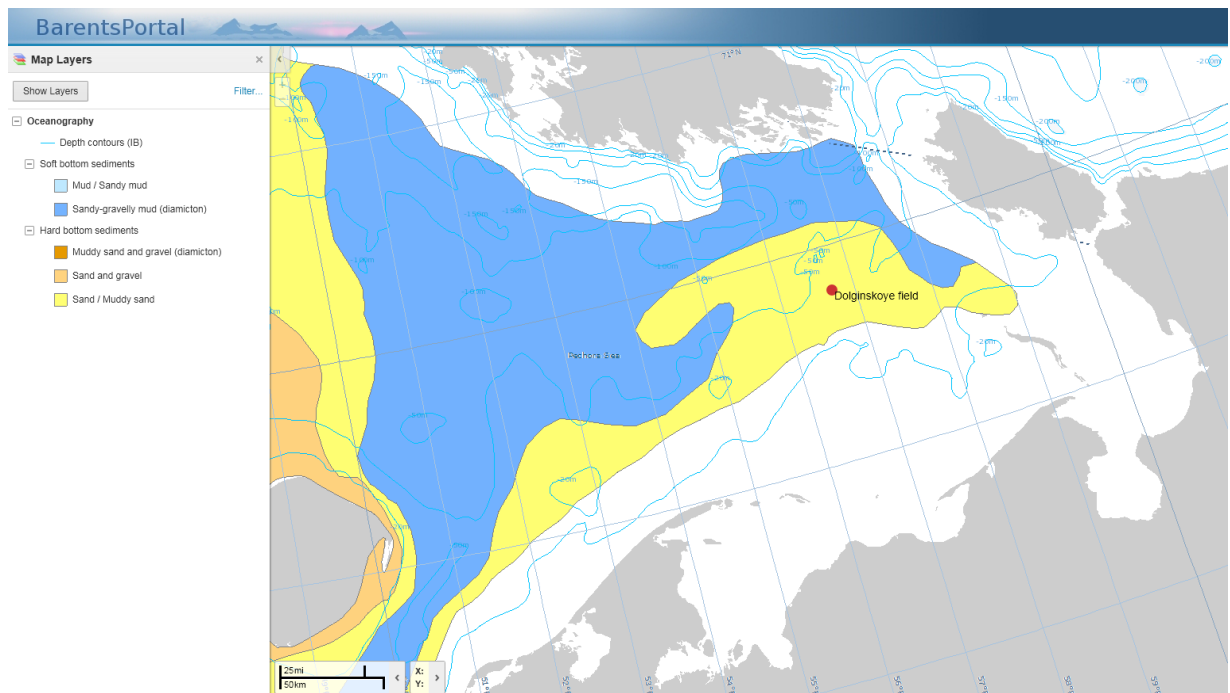

Figure 4 – Map of bottom sediments of the Pechora Sea (2012)⁹

The main challenges for sea bottom studies in the Arctic are⁶:

- Gas pickup (creates difficulties for acoustic method of rock studies);
- Presence of calcium hexahydrate (the temperature of this substance is unstable and causes changes in soil physical and mechanical characteristics);
- Anomalous soil properties (overstated density, over-consolidation, etc.).

In addition, studies of the soil parameters at the shallow water areas are embarrassed because the field region belongs to the area with possible presence of permafrost.

The original definition of the permafrost is the soil and rock which remain at temperatures below 0 °C for at least two consecutive winters and intervening summer. However, in marine sediments the freezing point is lower because of the saline water in the pores of sea sediments. The

⁹ Barents Portal. Available from: <http://geodata.npolar.no>. (read 22.02.2014)

temperature in subsea soil in shallow Arctic shelves is around $-1.6\text{ }^{\circ}\text{C}$, while in coastal areas it is slightly higher. The exact freezing point will depend on salinity and also the lithology¹⁰.

For engineers the ice-bonded permafrost (subsea permafrost with ice inclusions in such quantities that it can influence soil strength or seismic velocities¹¹) is of main interest for engineering design. Permafrost is a big challenge for drilling operation and installation of structures. Offshore soils can provide good foundation materials as long as they remain frozen. However these soils might be thawed that will lead to their volume change and reduced bearing capacity. Shallow ice-bonded permafrost is located near the seabed surface and may extend several kilometers offshore. The ice-bearing soils can be found in some areas of the Pechora Sea.

This information is important in order to estimate the maximum load on the seafloor that an offshore structure can create due to its weight and additional loads caused by ice, waves and currents.

One more problem is geohazards. A geohazard is defined as "A geological state, which represents or has the potential to develop further into a situation leading to damage or uncontrolled risk¹²". Geohazards are found in all parts of the earth and are always related to geological conditions and geological processes, either recent or past.

Important offshore geohazards include:

- Slope instability and mass wasting processes (including debris flows, gravity flows);
- Pore pressure phenomena (e.g. shallow gas accumulations, gas hydrates, shallow water flows, mud diapirism and mud volcanism, fluid vents, pockmarks);
- Seismicity.

Excess pore pressure development appears a critical aspect in most of the offshore geohazards. Submarine slope failure is the most serious threat on both local and regional scales. In addition to damaging offshore installations, slope failures may also cause devastating tsunamis.

Pore pressure is a fundamental variable in the behavior of soil. Despite this, our ability to accurately measure, monitor and predict pore pressures in offshore sediments is limited, and rarely done. Therefore, it is important to improve our understanding of excess pore pressure genesis (processes, migration), accurate measurement and its implications.

¹⁰ Lovo V., Elvernoi A., Antonsen P., Solheim A., Butenko G., Gregersen O. & Li Estoi O. 1990. Submarine permafrost and gas hydrates in the northern Barents Sea. Nr. 56 - Oslo

¹¹ Edited by Paepe R., Melnikov V. P. 1998. Permafrost Response on Economic Development, Environmental Security and Natural resources. Novosibirsk, Russia

¹² Offshore geohazards. 2010. International Centre for Geohazards. Available from: <http://www.ngi.no/en/Geohazards/Research/Offshore-Geohazards/>. (read 13.03.2014)

3.4. ICE CONDITIONS

Comparing the map of the Pechora Sea petroleum resources [Fig. 3] with the map of the ice concentration and maximum/minimum ice extent [Fig. 5] we can see that many oil and gas fields are located in shallow water areas, which are covered with ice during the winter season (“Prirazlomnoye”, “Dolginskoye”, etc.). According to Table 1, the sea is free of ice during about 110 days per year, but in the region of the field the ice-free period can vary from 3 to 7 month⁶.

Ice in the sea mainly has local origin, rarely accompanied with ice coming from the Kara Sea because of ice exchange between the seas. The ice of the land fast zone that can extent 10-15 km offshore is not strong until January (0,1-0,3 m thick) and starts to grow until February. Ice fracturing process begins in April-June depending on the location and, in the second part of June, it becomes entirely broken up. This fracturing is not stable and temporary continues during the winter resulting in formation of hummocks. The ice conditions are governed by currents, winds and tides and, thus, vary from one location to another. These main driving forces have the following influence on the ice drift:

- Drift velocity induced by the wind is in the range 0.1-0.9 m/s;
- Total velocity induced by combined action of all forces is up to 1,1-1,3 m/s.

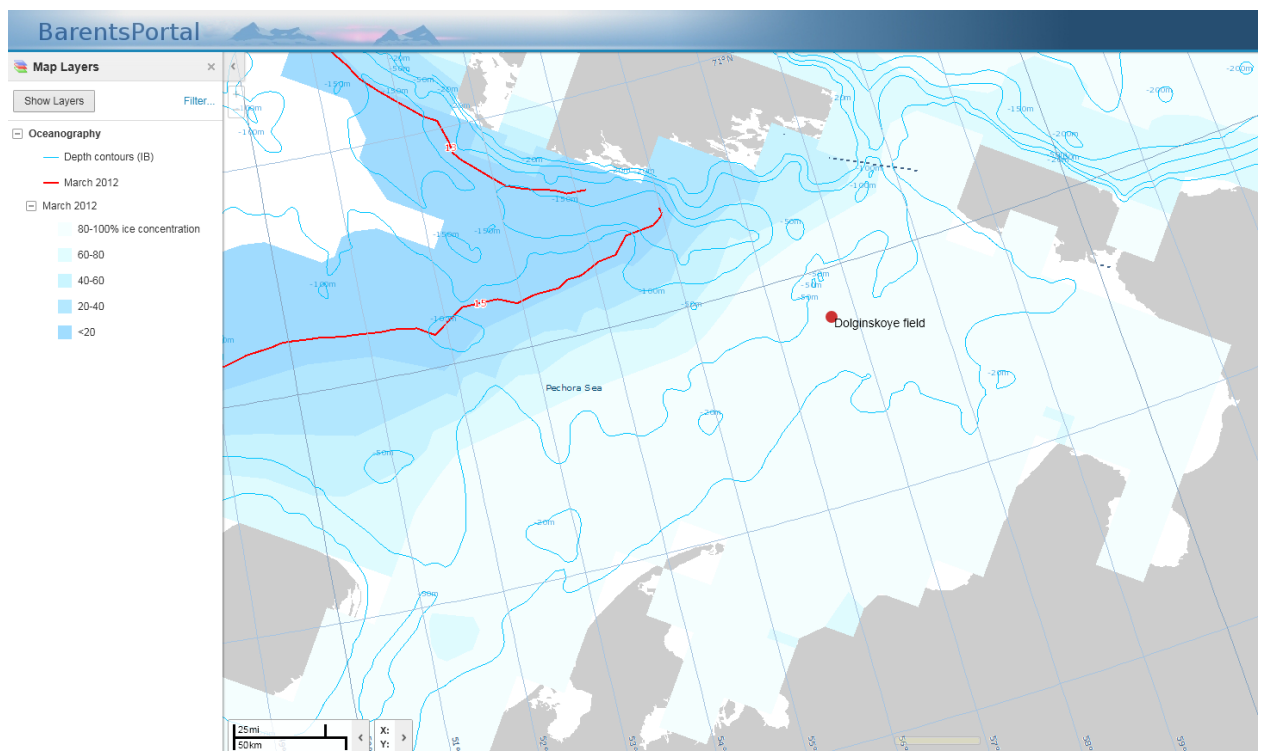

Figure 5 – Ice concentration, maximum/minimum ice extent in the Pechora Sea (March 2012). Bathymetry of the Pechora Sea⁹

In the sea different ice features can occur. They are level ice, rafted ice, ridges, hummocks and stamuchas (grounded hummocks).

According to the data from 2012 [Fig. 5], the ice concentration in the region of the field reaches 80-100 % in March. The sea ice extent reaches its maximum in March and its minimum in September, when the entire Pechora Sea is more or less completely ice-free.

The thickness of level ice start increasing in winter following the period of ice extension and reaches the maximum value, which is approximately 1,3 m in spring or beginning of summer. The extreme thickness is about 1,6 m. The ice cover in the peak period is not homogeneous. The thickness of the Pechora Sea level ice is governed by a regime of air temperature and, therefore, can be similar to the level ice in other Arctic regions.

The thickness of rafted ice in the sea can be up to 2,5-3 m thick.

The ice movement can cause the development of ridges, which can be grounded in shallow water areas. In deeper waters ice ridges cannot reach the seafloor and remain floating. The ridges are also divided into first-year and multi-year, but in the Pechora Sea the multi-year ridges have not been recorded. Ridges consist of blocks usually 0,3-0,6 m thick (up to 1,2 m) having the length 2-4 m.

The average parameters of the ice ridges in the Pechora Sea are the following:

- sail height (h_s) – 0,5-2,5 m (up to 4,6 m)
- keel draught (h_k) – 3-6 m (up to 12-18 m)
- consolidated layer can reach twice thickness of level ice

In February the sea surface coverage by hummocks can reach 60 to 80%, in April the hummocks can cover entire sea surface. In balls, the drift zone hummocking in February is estimated as 3-4 balls and 5 balls for April hummocking. The average hummocking in the land fast zone is estimated to be 3-4 balls.

Stamuchas (grounded ridges) are usually located at 7-15 m water depth. They were not observed at more than 20 m water depth. They usually consist of unconsolidated ice blocks with porosity of 30-35 %. The sail height is up to 7-12 m. The length is from 30 to 150 m and more.

Icebergs are an important issue of the Barents Sea. Icebergs are formed when glaciers on islands in the northern Barents Sea (i.e. on Franz Josef's Land) slide out over the sea and break off into large pieces, and are carried away by the wind and the ocean sea currents. When they float into warmer waters, they melt relatively quickly, thus the icebergs are very rare to be found in the south Barents Sea¹³. In the Pechora Sea the icebergs do not usually occur⁸. Therefore, for GBS installed in these regions the chances to be collided with icebergs are small. As the Dolginskoye field is located at approximately 40 m depth, the collision risks are even smaller as the big icebergs will ground in shallow water areas.

In open waters, the combination of environmental forces can be critical for any offshore structure. In order to design offshore facilities for the shallow water field development the experience gained from other areas with the Arctic (or nearly Arctic) conditions can be used. These areas include the Beaufort Sea, the Sakhalin Island, the Caspian Sea and others. It is very important to collect the environmental data, because the wrong estimation of possible loads can

¹³ Srinivasan N., Singh S. 2008. Design of a Non-Ship-Shaped FPSO for Sakhalin-V Deepwater. SPE 114882

result in damage or even collapse of any structure, and consequently to serious environmental pollutions.

Ice conditions including the information about iceberg location and drift direction can be defined by aerial surveys or visual observations from ships, aircraft or ships radar data and satellites monitoring. From satellites we can make large-scale maps of the Arctic, using radar (SAR) or optical systems. Each method has its advantages and disadvantages. The first one provides a high resolution and it is able to work in any conditions, but the technology is expensive and only numerous satellites are equipped with the system. The second one makes optical images with high resolution as well, but its application is limited by daylight and clouds¹⁴. Moreover, the satellites imagery is inefficient for detection of small icebergs and small ice features.

Empirical data on ice strength¹⁵

It's known that the ice loads on offshore structures mainly depends on the ice thickness, ice drift velocity and ice strength. For this project empirical data about the vertical and horizontal ice strength in the Barents Sea was analyzed.

The measurements were conducted by the UNIS's student group AT-307 on the sea ice in the Sveasunda fjord, Svalbard. The ice is referred to as first-year ice, since it is growing every winter, but the area is completely ice-free during summer and fall.

For the testing on the sea ice, a 5-by-5 polygon was set up to obtain a sufficient amount of data in order to exclude any local variations. The 5-by-5 polygon consisted of 25 poles each spread 25 m apart, and samples were taken at every location.

To know the ice conditions of the sample locations at each pole; the ice thickness, the freeboard and the snow height were measured.

Table 2 shows the values of freeboard, ice thickness, and snow height at the polygon.

Table 2 - Sea ice conditions in the Sveasunda fjord¹⁵

Thickness	Average	Min	Max
Freeboard [cm]	0,3	-3	8
Snow [cm]	-22,4	-30	-14
Ice [cm]	60,9	44	68

¹⁴ Total Professors Associates. 2013. The course of lectures "Arctic design. Offshore structures and ships". Gubkin Russian State University of oil and gas

¹⁵ Study group AT-307. 2014. UNIS's course AT-307 «Arctic Offshore Engineering – Fieldwork». Group report. Longyearbyen

The horizontal and vertical samples were taken using Kovacs type ice drilling equipment. Each sample was cut to a length of 175 mm by a circular saw. In order to take the vertical samples, the ice cover was directly drilled by Kovacs type drill. For taking the horizontal samples, a vertical core with a diameter of 250 mm was drilled first using a big auger. From this big sample a horizontal core was drilled with the same Kovacs type drill at 20-40 cm from the top of the vertical core.

For testing the uniaxial compressive strength of ice cores, the portable compression rig “KOMPIS” was used together with specialized KOMPIS software for receiving the data [Fig. 6].



Figure 6 – Testing the ice cores in the portable compression rig “KOMPIS” (left) and recording the data (right)¹⁵

The elastic behavior of the considered samples relates to linear part of the stress-strain dependence and could have been described using the next formula:

$$\sigma = E\varepsilon \quad (1)$$

Where: where σ – stress, ε – strain, E – Young’s modulus of a material.

For essential calculations we used next formulas:

$$\sigma = \frac{F}{A} \quad (2)$$

Where: F – force, A – area of an ice cylinder.

$$\varepsilon = \frac{u}{L_0} \quad (3)$$

Where: u – displacement, L_0 – initial length of ice cylinder.

In each point of the matrix, temperature and salinity were measured and both horizontal and vertical compression tests were conducted in order to get an understanding of the spatial (i.e. local) variability of the ice strength in the area.

The ice temperature was in the range of -3°C to -7°C at the depth where strength was measured. The first day of compression tests was conducted with an air temperature of -12°C , while the second day the air temperature was -3°C .

The ice strength from the compression tests were compared to the temperature and salinity, as these parameters are known to affect the strength to a large degree. The vertical and horizontal samples were compared in order to establish the structure of the ice.

Figure 7 shows that the average strength of the vertical samples is stronger than the horizontal, which was expected due to the assumption of columnar type of ice. It is known from ice mechanics and ice physics that columnar ice has a strong axis and a weak axis. For columnar ice the c-axis is the weak axis (horizontal) and the vertical axis is the strong axis. However, in some points the horizontal strength was higher than vertical. Therefore, the local variability in the sea ice could have induced some discrepancies in the strength of the ice.

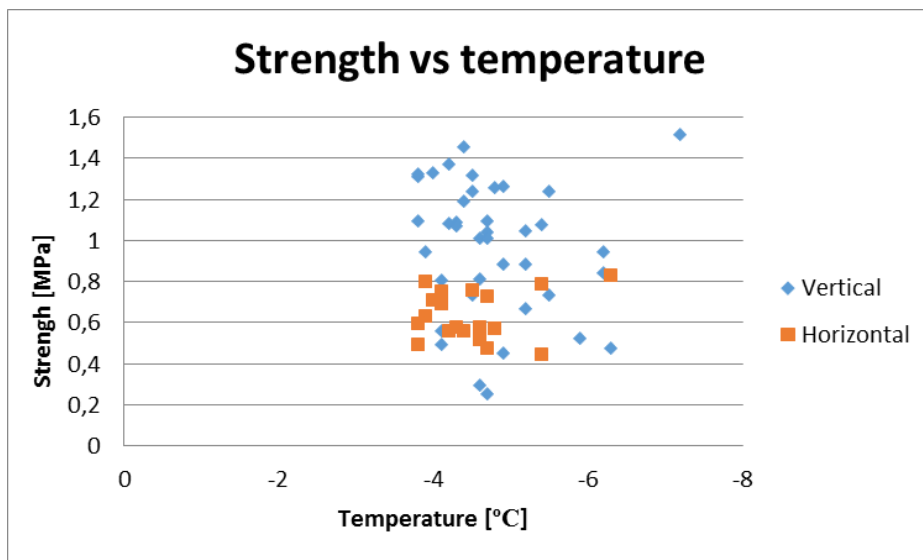

Figure 7 – Vertical and horizontal strength of ice vs. temperature¹⁵

The strength dependency on salinity is plotted in Figure 8. In general, the strength decreases with increasing salinity. The vertical samples have a wider range of salinity and the dependency is more evident than for the horizontal samples, which have a more narrow range.

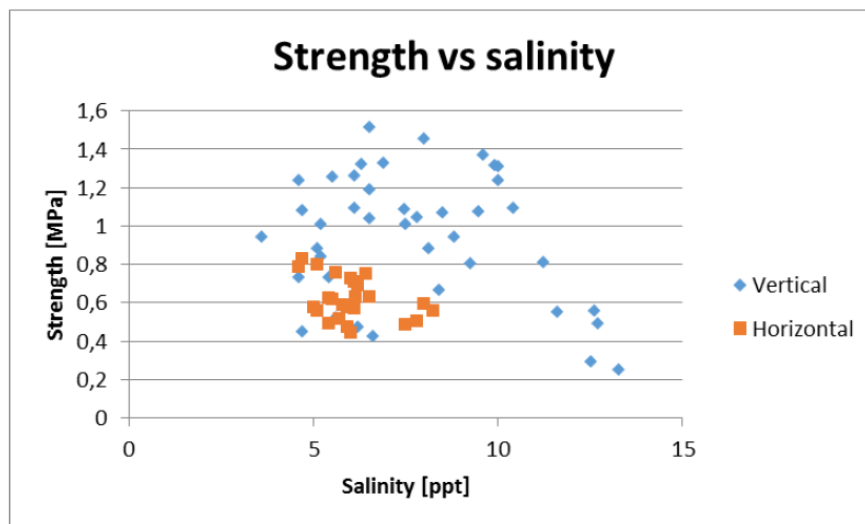

Figure 8 - Vertical and horizontal strength of ice vs. salinity¹⁵

The highest compressive strengths were measured in the middle of the ice column. Ice gets weaker at the top and bottom of the column. This complies with the higher salinity measured at the top and bottom of the ice sheet.

Ice loads on structures occur when the ice sheet contacts the structure while drifting on the water surface. Therefore, depending on the ice failure mode, the total loads mainly influenced either by horizontal compressive ice strength or flexural ice strength. In order to estimate minimum ice-breaking capacity of the Arctic structures the maximum value of horizontal compressive strength and flexural strength should be taken.

The maximum measured value of the horizontal compressive ice strength, which was 0,83 MPa, was obtained testing horizontal ice sample in the point 1,3. The measured salinity and ice temperature of the sample were 4,7 ppt and -4,8 °C respectively. The maximum vertical strength, 1,52 MPa, was measured in the other point.

The average parameters for the whole polygon are the following:

- horizontal compressive ice strength - 0,62 MPa
- vertical compressive ice strength - 0,95 MPa
- ice temperature - -4,9 °C
- ice salinity - 7,1 ppt

The next equation was used for determining ice flexural strength¹⁶:

$$\sigma_f = 1,76e^{-5,88\sqrt{V_b}} \quad (4)$$

Where: σ_f – flexural strength, V_b – brine volume in ice sample.

¹⁶ Løset S. 2013. Ice Mechanics. Rheology. Lecture 4, the course AT-327, UNIS

For ice porosity calculation was used Cox and Weeks theory¹⁷:

$$\eta = \eta_b + \eta_a = V_b + V_a \quad (5)$$

Where: η – sea ice porosity, η_b - brine fraction, η_a – gas fraction, V_b – brine volume in ice sample, V_a – air volume in ice sample.

Brine fraction:

$$\frac{V_b}{V} = \eta_b = \frac{\rho_i S_i}{F_1(T)} \quad (6)$$

Gas fraction:

$$\frac{V_a}{V} = \eta_a = 1 - \frac{\rho_i}{\rho_{pi}} + \rho_i S_i \frac{F_2(T)}{F_1(T)} \quad (7)$$

$$\rho_{pi} = 0,917 - 1,403 * 10^{-4} * T \quad (7.1)$$

Where: ρ_{pi} – density of pure ice, ρ_i – density of sea ice, S_i – salinity of the ice-sample, V – total volume of ice sample.

Temperature is given in °C, while the functions F1 and F2 are given in tables in Cox and Weeks (1983). These equations are valid for cold ice, which is defined as ice colder than – 2 °C.

The obtained value of the flexural strength for the same sample (from the point 1,3) is 0,47 MPa.

Conclusion:

According to data from the source dated by 1999⁸, the ice salinity in the Pechora Sea is about 5-6 ppt in winter and 2,5-3 ppt in spring. An average value of 1,37 MPa and a value of 1,92 MPa at 1% probability of exceedance are suggested for designing structures to be installed in the Pechora Sea. These values are, however, twice higher than those were measured at Svalbard, the Barents Sea. The design flexural strength for the Barents Sea ice is also higher than measured by us and has the value of 0,52 MPa¹³. As the official values are higher than the values measured by us, the use of the official values can be regarded as conservative (on the safe side).

¹⁷ Cox G.F.N. and Weeks W.F. 1983. Equations for determining the gas and brine volumes in sea-ice samples. Journal of Glaciology. Vol. 29. No. 102. 1983

10. FIELD GEOLOGY

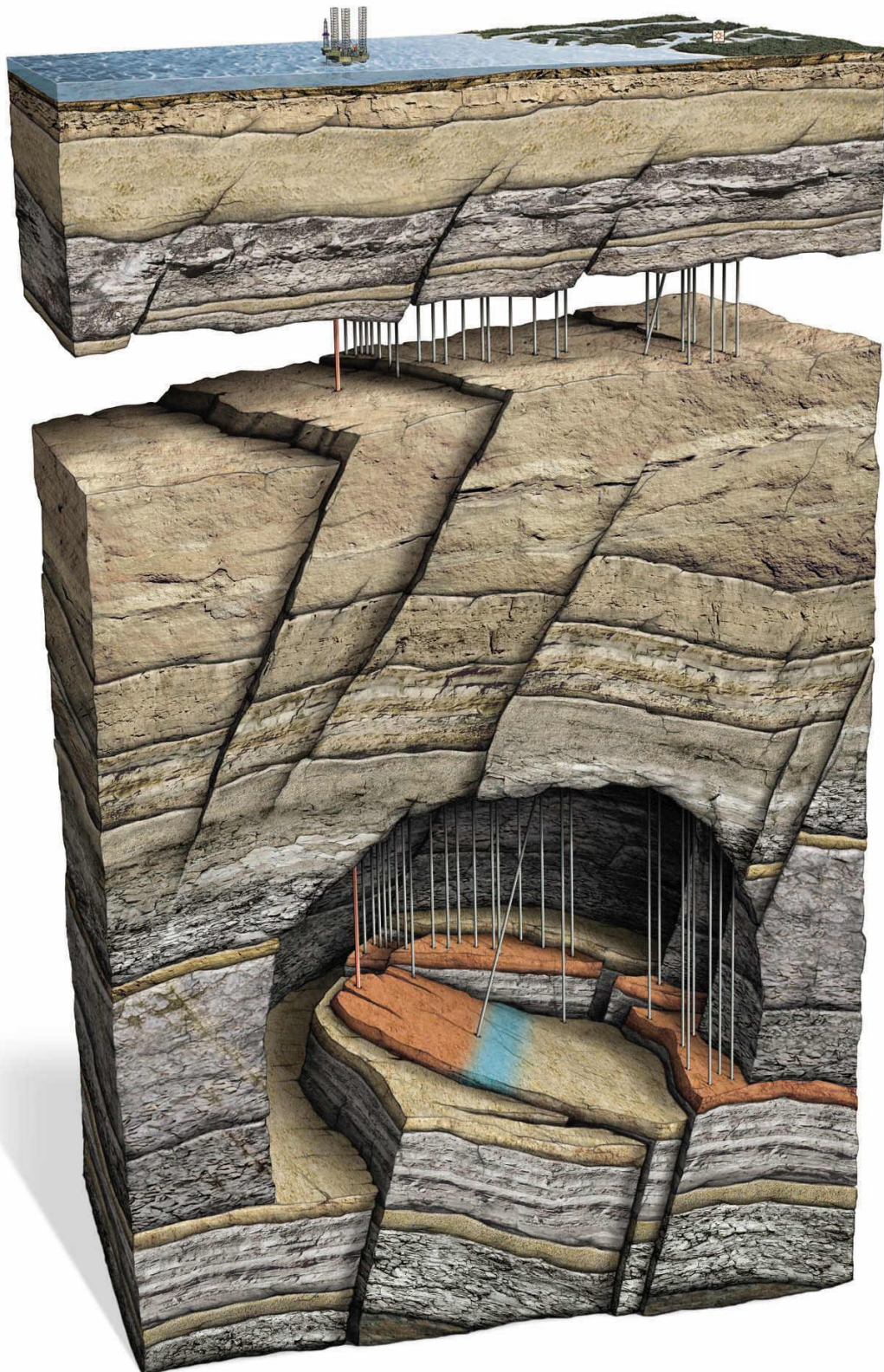

The main part of the Arctic shelf is a platform area having a sedimentary cover up to 10-20 km thick that forms basins favorable for accumulation of oil and gas. In general, Arctic natural reservoirs have heterogeneous geological structure. It can be explained by differences in their ages and geological conditions of the Arctic basins. The Dolginskoye field belongs to the Timan-Pechora Basin which is a part of the Arctic shelf OGB together with the Barents Sea Basin, the Southern Kara Basin and the Laptev Sea Basin⁸.

The geological map of the field is shown in Figure 9.

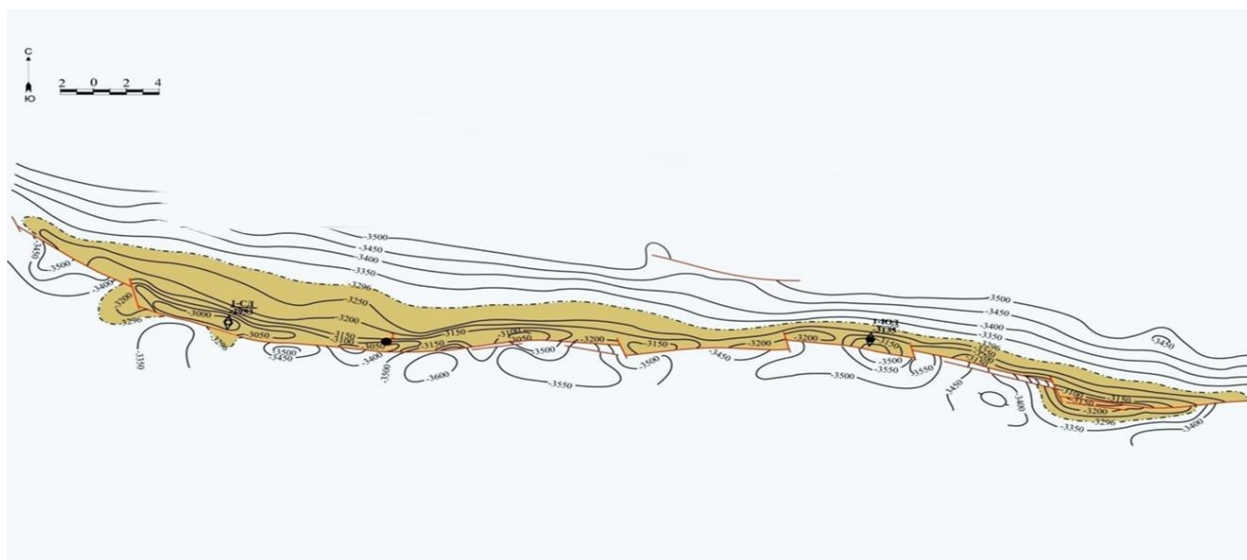

Figure 9 – Geological map of the Dolginskoye field¹⁸

The size of the Dolginskoye field along its long axis is approximately from 75 to 90 km depending on depth of the field¹⁹. The field is almost equally divided into two parts, the South-Dolginskaya and the North-Dolginskaya positive structures.

The general thickness of the sedimentary cover in the region of the Dolginskoye field is about 6-8 km. Two exploration wells, «1-ЮД» and «1-СД», have been drilled by LLC «Gazflot» at the South-Dolginskaya and the North-Dolginskaya structures respectively [Fig. 9]. Both wells are near-crestal. Maximum section of sedimentary cover, 3900 m, was drilled at South-Dolginskaya structure, the well #1. The oldest founded formation is Upper Devonian²⁰. Now, the exploration of the field is continuing.

¹⁸ Gazprom нефть шельф. 2011. Report «Development of the Prirazlomnoye and Dolginskoye fields». Moscow. ООО «Газпром нефть шельф». 2011. Доклад «Обустройство Приразломного и Долгинского месторождений». Москва

¹⁹ Forecast of presence of oil and gas in the Dolginskaya geological structure based on simulation results using optically active materials. Vovk V.S, Dzyublo A.D, Demetry T.V, Ryabukhina S.G, Zaitsev A.V. Oil and Gas Geology, 3-2008. Available from: http://www.geoinform.ru/?an=vovk_ru. (read 16.05.2014). Прогноз нефтегазоносности Долгинской площади по результатам моделирования на оптически-активных материалах. Вовк В.С., Дзюбло А.Д., Дмитриевская Т.В., Рябухина С.Г., Зайцев А.В., Геология нефти и газа, 3-2008

²⁰ VNIIGAS. 2008. Report “Synergy of the Prirazlomnaya project with other projects”. ВНИИГАЗ. 2008. Реферат «Обеспечение синергии проекта обустройства Приразломного нефтяного месторождения с другими проектами»

According to geological oil and gas zonation, the Dolginskoye field belongs to the Varandey-Ad'zvinskaya oil-and-gas bearing region, within which 5 oil-bearing zones are found. The zones are following:

- Silurian - Lower Devonian carbon-bearing;
- Mid-Devonian - Frasnian terrigenous;
- Upper Devonian - Lower Frasnian carbon-bearing;
- Permian - Carboniferous carbon-bearing;
- Lower Triassic terrigenous.

Estimation of C1+C2 categories of the Dolginskoye field's recoverable reserves gives the value of about 235,8 mln. tonnes (C1 – 0,9 mln. tonnes). According to the data from 2000, 92,4 % of recoverable reserves are in the North-Dolginskaya structure, 78,2 % of which related to the Upper Permian terrigenous deposits²⁰. Moreover, based on the well log survey data the reservoirs of the North-Dolginskaya structure have better quality (porosity and permeability) than the South-Dolginskaya. Therefore, development of the field to be started from the North-Dolginskaya structure.

A detailed data on resources of the Dolginskoye field is represented in Table 3¹⁸.

Table 3 – Resources of the Dolginskoye field¹⁸

Number of geological horizon	Explored oil resources, MTOE			
	Total		Recoverable	
	C1 category	C2 category	C1 category	C2 category
Upper Permian terrigenous deposits				
I, II, III, IV	-	584528	-	175357
Lower Permian - Carboniferous carbonate deposits				
II+III, IV	2976	198555	892	59567
TOTAL	2976	783083	892	234924

11. ICE LOADS ON FIXED STRUCTURES

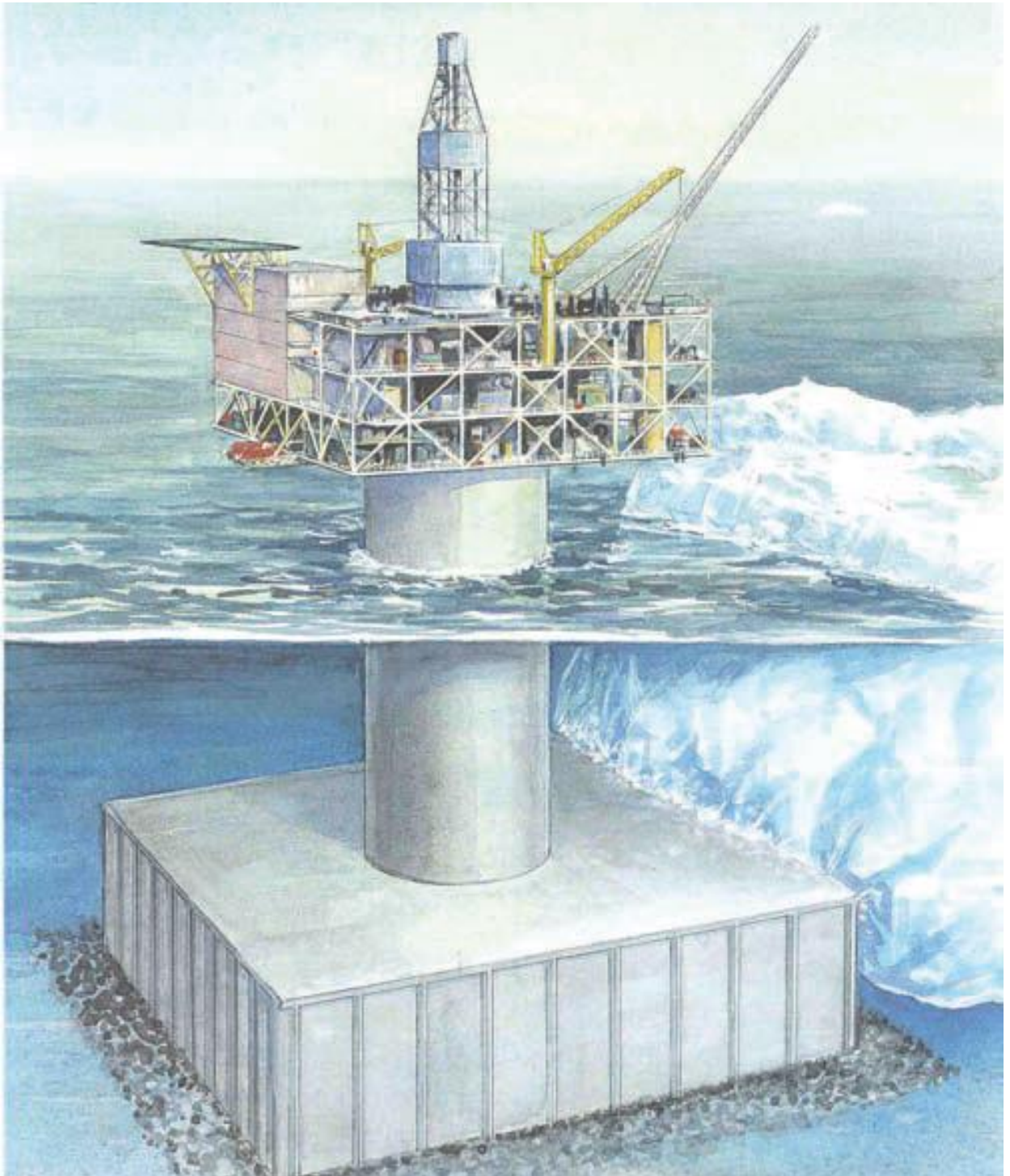

11.1. ICE ACTIONS

In order to ensure the capability of the Arctic offshore structures to withstand the severe environmental conditions such as ice features a special standard that provides Arctic requirements and recommendations has been developed. Its name is ISO 19906 Arctic Offshore Structures. In the standard's clause #8 ice actions and action effects are described. In order to design any structure against ice loads all possible design situations have to be considered.

Table 4 represents a detailed classification of ice actions.

Table 4 – Classification of ice actions²¹

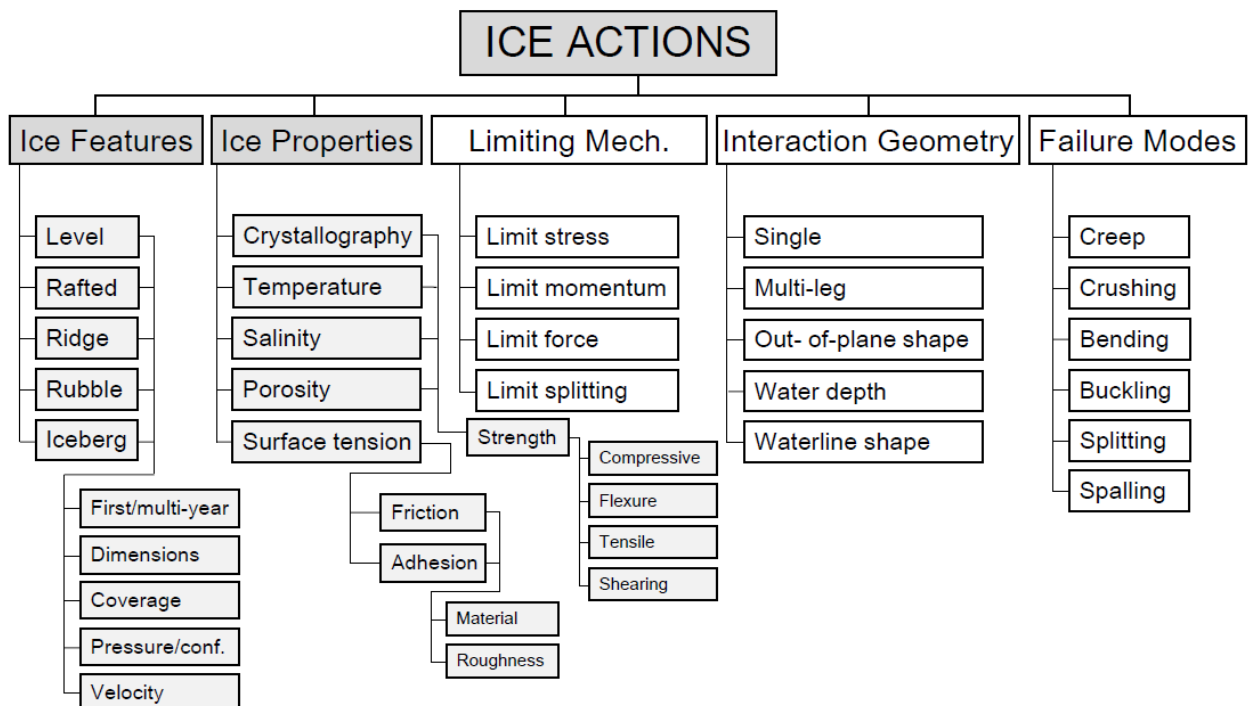

The main scenarios of ice interaction with the structure involve limiting mechanisms, which can be divided into several categories.

According to the one source there are 3 categories²²:

- Limit energy (involve the impact of icebergs, ice islands or large multiyear floes and challenges in the design involve the proportion of the initial kinetic energy that is transmitted to the structure and the response of the structure);
- Limit force (the action is governed by the driving forces on the ice in contact with the structure, whether due to wind stress or ridge building processes);

²¹ Løset S. 2013. The ice cover and drift of sea ice. Lecture 3, the course AT-327, UNIS

²² McKenna R., Spring W., Thomas G. 2011. Use of the ISO 19906 Arctic Structures Standard. The Arctic Technology Conference, Houston, Texas, USA. OTC 22074

- Limit stress (ice action is governed by the local failure of the ice against the structure. Ice interaction with the structures of different shapes and potential failure modes are shown in Table 5).

According to other sources (UNIS' lectures) there are 4 categories of limiting mechanisms: limit stress, limit force, limit momentum and limit splitting. Depending on each design situation it might be required to consider a combination of several mechanisms.

In the ISO 19906 ice actions are determined for ELIE (Extreme-Level Ice Event) and ALIE (Abnormal-Level Ice Event) with relevant annual exceedance probability levels α ²³:

- ELIE actions are specified at $\alpha = 10^{-2}$
- ALIE actions are specified at $\alpha = 10^{-4}$

It means that the designed structure must be able to withstand extreme ice conditions such as 100-year load for ELIE and 10 000-year load for ALIE.

ELIE and ALIE correspond to Ultimate limit state design and Abnormal (accidental) limit state design respectively, which are in turn based on Load Resistance Factor Design (LRFD). In LRFD load and resistance distributions are integrated to determine the probability that the load exceeds the resistance [Fig. 10].

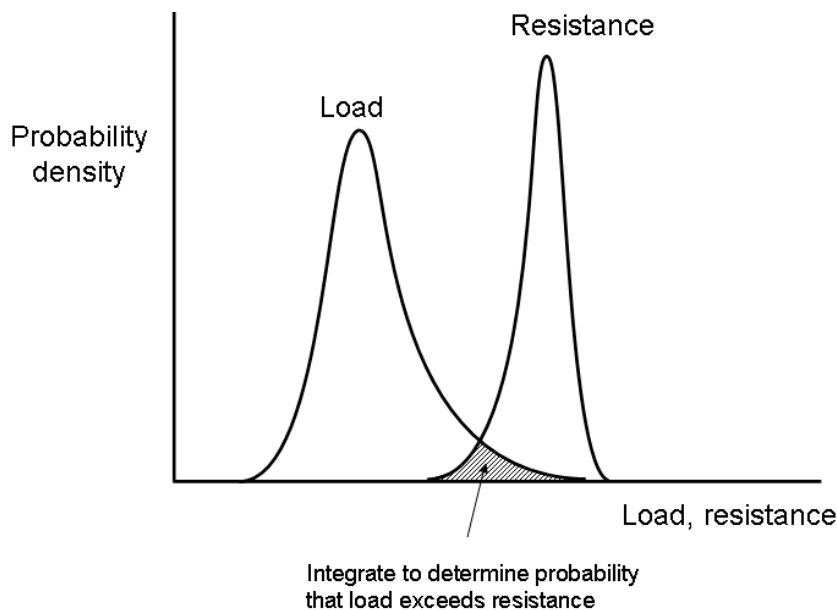

Figure 10 - Probability of failure determined from load and resistance distributions²⁴

²³ Løset S. 2013. Ice Actions and Action Effects. ISO 19906 Arctic Offshore Structures. Lecture 7, the course AT-327, UNIS

²⁴ Fuglem M., Stuckey P., Jordaan I. 2011. Probabilistic Ice Loads Assessments for Arctic Regions: Inputs for Calibration of ISO 19906. The Arctic Technology Conference, Houston, Texas, USA. OTC 22070

Table 5 – Structural form elements and ice/element interaction²⁵

STRUCTURAL ELEMENT	DESCRIPTION	ICE/ELEMENT INTERACTION
Vertical Wall Wall		Crushing
Wide Wall		Pileup and Multimodal Failure
Cylinder		Crushing and Clearing Ridge Flexure or Crushing
Inclined Plane Upbreaking		Flexural Failure, Rideup, Adfreeze
Downbreaking		Flexural Failure, Submergence
Inflected		Flexural Failure, Rideup, Pileup
Cone		Flexural Failure, Rideup, Adfreeze, Clearing Ridge Flexure
Amorphous Ice Wall		Multimodal Failure, Penetration by Ice
Wedge or Spike		Gradual Deceleration During Penetration by Wedge

²⁵ Bercha F.G. 1994. Evolution of Arctic Marine Structural Forms. The 26th Annual Offshore Technology Conference, Houston, Texas, U.S.A. OTC 7461

All actions of ice related to offshore structures can have global and local character. The global action and the local ice pressure present significant importance for the Arctic structural design. The global action is the action exerted on the whole structure at any instant time. This action is important in terms of the overall strength, the horizontal stability and the overturning moment of the structure. The local pressure is the pressure exerted on a limited part of the contact area (usually up to 2 m). This parameter is very important for the structural local strength estimation²⁶.

11.2. ICE LOADS ON VERTICAL STRUCTURES

Global ice action on vertical structures can be found using the following equation²⁷:

$$F = h \int_{-\pi/2}^{\pi/2} \sigma_c \cos \varphi R d\varphi = h\sigma_c 2R = \sigma_c Dh \quad F = h \int_{-\pi/2}^{\pi/2} \sigma_c \cos \varphi R d\varphi = h\sigma_c 2R = \sigma_c Dh \quad (8)$$

Where: σ_c – unconfined compressive strength, D – diameter of structure, R –radius of structure, h – ice thickness.

For the vertical structures the main ice failure mode is crushing and for the force estimation we should determine the unconfined compressive ice strength [Fig. 11].

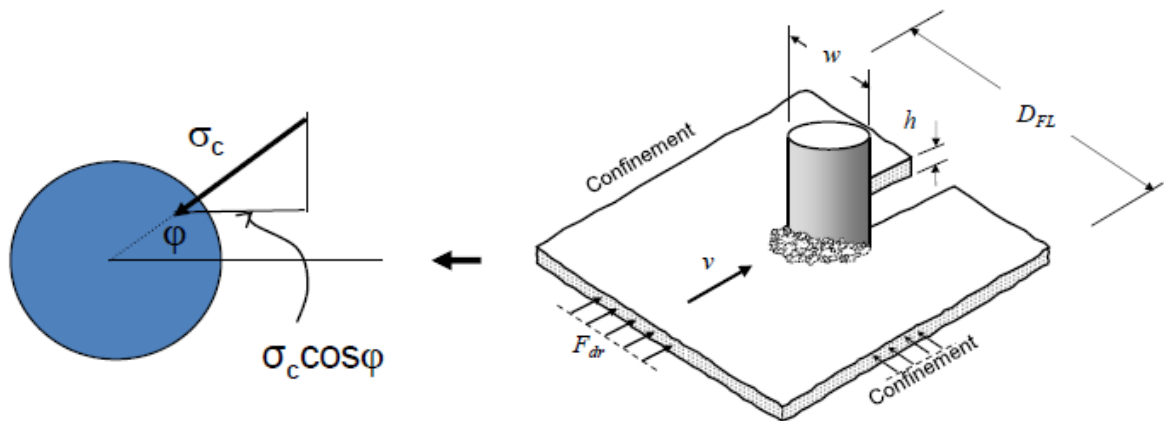

Figure 11 - Global ice actions on vertical structures²⁷

The Korzhavin equation (1971), which was originally aimed to estimate ice forces acting on narrow structures like bridge piers, can be used to estimate ice force on vertical structures taking into account shape, contact and indentation factors. The load can be found as²⁷:

$$F = IKm\sigma_c Dh \quad F = IKm\sigma_c Dh \quad (9)$$

²⁶ Bulakh Maria, Zolotukhin A.B., Gudmestad O.T. 2011 .The Kara Sea Offshore as a Strategic HC Recourse Base in the 21. Possible Solutions of Developing According to the Estimate of the Economy. Uncertainties by Fuzzy Theory. SPE 149655. SPE Arctic and Extreme Environments Conference & Exhibition, Moscow, Russia

²⁷ Løset S. 2013. Global and Local Ice Loads. Lecture 6, the course AT-327, UNIS

Where: I - indentation factor, K - contact factor, m - shape factor, σ_c – unconfined compressive strength, D - structure diameter, h - ice thickness.

In case of columnar ice the indentation factor I is in the range of 3.5 for high aspect ratio (D/h) to 4.5 for low aspect ratio. In case of granular ice the factor I varies from 1.2 for high aspect ratio to 3 for low aspect ratio. The contact factor K depends on the contact area between the structure and the ice. It is low for cold, brittle ice and closer to 1 for warm, ductile ice. The shape factor m is 1 for rectangular structures and 0.9 for circular structures²⁸.

However, this method could be inefficient for estimating the load on wide structures as the calculation results could vary significantly because of the size effect (the force per unit contact area depends on this contact area²⁹), many assumptions and a wide range of values of the factors.

11.3. ICE LOADS ON STRUCTURES WITH SLOPING WALLS

Structure design should include sloping walls that allows to reduce ice loads due changing the ice failure mode from crushing to bending. The walls can be plane, cone or facet types. The slope affects the characteristic breaking frequencies reducing potential resonance problems. However, rubble accumulation at the structure and high velocity of the advancing ice sheet may reduce the advantage of sloping structures³⁰.

It this work the Croasdale model (1980) for ice on a plane slope is considered to estimate possible ice loads:

This is the two-dimensional beam theory, according to which an ice sheet assumed as a beam on elastic foundation. The model considers the vertical and horizontal ice forces. It is valid only for wide structures.

The ice loads are limited by bending strength, shear stress capacity, ice thickness, friction and sloping of the structure. The limits of the vertical and horizontal loads are expressed by the following formulas³⁰:

$$V = 0.68\sigma_f W \left(\frac{\rho_w g h^5}{E}\right)^{1/4} \quad (10)$$

$$H = 0.68\sigma_f W \left(\frac{\rho_w g h^5}{E}\right)^{1/4} \frac{\sin \alpha + \mu \cos \alpha}{\cos \alpha - \mu \sin \alpha} \quad (11)$$

Where: V – vertical ice force, H – horizontal ice force, W – diameter or width of the structure at MWL (mean water level), ρ_w – density of sea water, g - acceleration due to gravity, h – ice thickness, E – Young’s modulus of ice, μ - friction coefficient, α – slope angle.

²⁸ University Courses on Svalbard. 2001. AT-204 Thermo-Mechanical Properties of Materials, 3 vt, 9 ECTS. Examination – suggested solution (problem sets 2 and 3)

²⁹ Bellendir E.N., Vedeneev B.E., Toropov E.E. 2000. Analysis of Various Designs of the Stationary Platform Substructures for the Pechora Sea Shelf. The Tenth International Offshore and Polar Engineering Conference Seattle, USA

³⁰ Løset S. 2013. Ice Loads on Sloping-Sided Structures. Lecture 8, the course AT-327, UNIS.

The total horizontal ice force is the sum of the breaking force (left part of the equation) required breaking the ice and ride-up force (right part) required pushing ice blocks up the slope.

$$\frac{F_H}{D} = \sigma_f \left[\frac{\rho_w g h^5}{E} \right]^{1/4} C_1 + z h \rho_i g C_2 \quad \frac{F_H}{D} = \sigma_f \left[\frac{\rho_w g h^5}{E} \right]^{1/4} C_1 + z h \rho_i g C_2 \quad (12)$$

$$C_1 = 0.68 \left(\frac{\sin \alpha + \mu \cos \alpha}{\cos \alpha - \mu \sin \alpha} \right) C_1 = 0.68 \left(\frac{\sin \alpha + \mu \cos \alpha}{\cos \alpha - \mu \sin \alpha} \right) \quad (12.1)$$

$$C_2 = (\sin \alpha + \mu \cos \alpha) \left(\frac{\sin \alpha + \mu \cos \alpha}{\cos \alpha - \mu \sin \alpha} + \frac{\cos \alpha}{\sin \alpha} \right) C_2 = (\sin \alpha + \mu \cos \alpha) \left(\frac{\sin \alpha + \mu \cos \alpha}{\cos \alpha - \mu \sin \alpha} + \frac{\cos \alpha}{\sin \alpha} \right) \quad (12.2)$$

Where: F_H – total horizontal ice force, D – diameter or width of the structure at MWL (mean water level), ρ_i – density of sea ice, ρ_w – density of sea water, g - acceleration due to gravity, h – ice thickness, E – Young’s modulus of ice, μ - friction coefficient, C_1 and C_2 - coefficients depending on the slope angle and the friction coefficient μ , z –height reached by the ice on the slope.

Analyzing the calculation we can conclude that the structures with steeper walls have higher ice loads as more ice crushing occurs. Moreover, friction effects are significant for slopes steeper than 45° . It is important to fabricate and maintain smooth surfaces for sloping structures to minimize the ice friction and, consequently, ice loads on the structures. The influence of ice drift velocity should be considered if the velocity exceeds 0.5 m/s ³⁰.

In addition, the accumulation of ice at the slope could lead to so called Adfreeze effect. When the ice that has a contact with the structure remains stationary for some time, it may freeze to the structure’s wall surface and before it can start to move again the adfreeze bonds have to be broken²⁹. It creates an additional horizontal ice load that can be found by using the following formula³⁰:

$$F_{\text{adfreeze}} = \frac{\pi h q W}{\tan \alpha} F_{\text{adfreeze}} = \frac{\pi h q W}{\tan \alpha} \quad (13)$$

Where: F_{adfreeze} – horizontal ice load due to adfreezing (MN), h - ice thickness (m), q - adfreeze bond strength (0.3-1 MPa), W - width of structure (m), α – slope angle.

11.4. ICE RUBBLE LOADS

In order to determine ice interaction with wide GBS structures having sloping walls subsea video records were made and the model investigations were conducted in a special ice basin [Fig. 12].

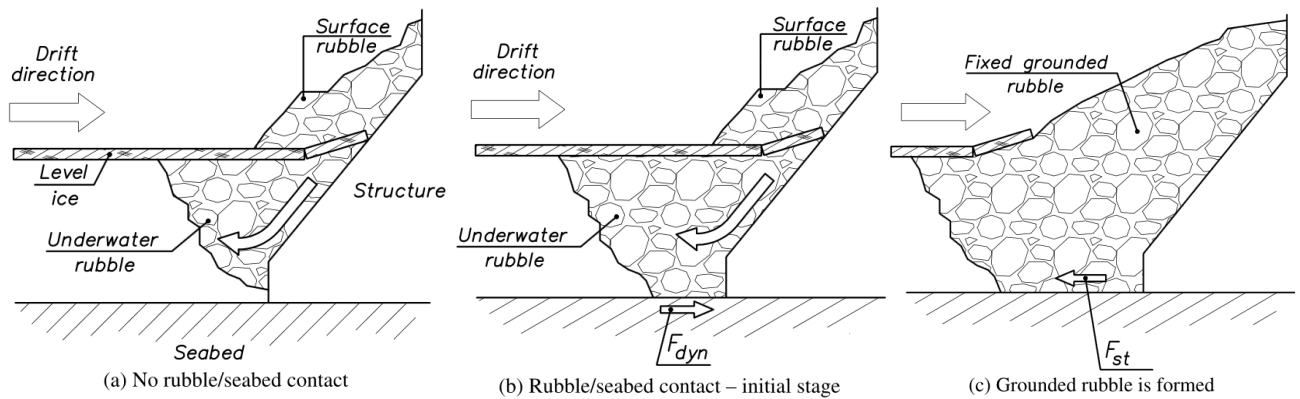

Figure 12 – Forming grounded ice rubble in front of platform³¹

In the beginning ice blocks are in constant motion toward the structure's wall. While going underwater, some ice blocks have a downward slide along the sloping surface and the floatation force tends to bring them to the surface [Fig. 12a]. Once the sinking ice blocks reached the bottom, they start sliding along the seabed that is accompanied by a friction force [Fig. 12b]. This increases the total ice load on the structure. The continuous ice motion toward the platform makes the ice rubble bigger and the ice breaking area shifts to the outer boundary of the rubble. In front of the platform, the zone of steady bottom-connected grounding rubble forms [Fig. 12c]. Some part of the ice loads will be taken by the seafloor that reduces the total ice force acting on the platform³¹.

11.5. ICE RIDGE LOADS

As was mentioned above, the conditions of the Pechora Sea could include hummock or ice ridges. They can be defined as a hillock of broken ice which has been forced upwards by the pressure.

The ridge is usually consists of 3 parts, which are the following³²:

- a sail, which is the upper part, located on the surface of the ice formation and usually made up of a number of small ice pieces often loosely bonded together
- a consolidated layer, which is refrozen layer in the middle part of the ridge. Its strength is close to the strength of first-year ice. The thickness of this layer can have a wide range and different analyses show different results, but according to laboratory tests of the broken ice rubble refreezing the thickness of the refrozen layer could be two times more than the thickness of the surrounding level ice

³¹ Karulin E. B., Karulina M. M., Blagovidov L. B. 2007. Ice Model Tests of Caisson Platform in Shallow Water. International Journal of Offshore and Polar Engineering. ISSN 1053-5381

³² Timco G.W., Frederking R., Kamesaki K., Tada H. 1999. Comparison of ice load calculation algorithms for first-year ridges. Proceedings International Workshop on Rational Evaluation of Ice Forces on Structures, REIFS'99, pp. 88-102

- a keel, which consists of many loosely-bonded ice blocks

The common scheme of the ridge configuration is represented in Figure 13.

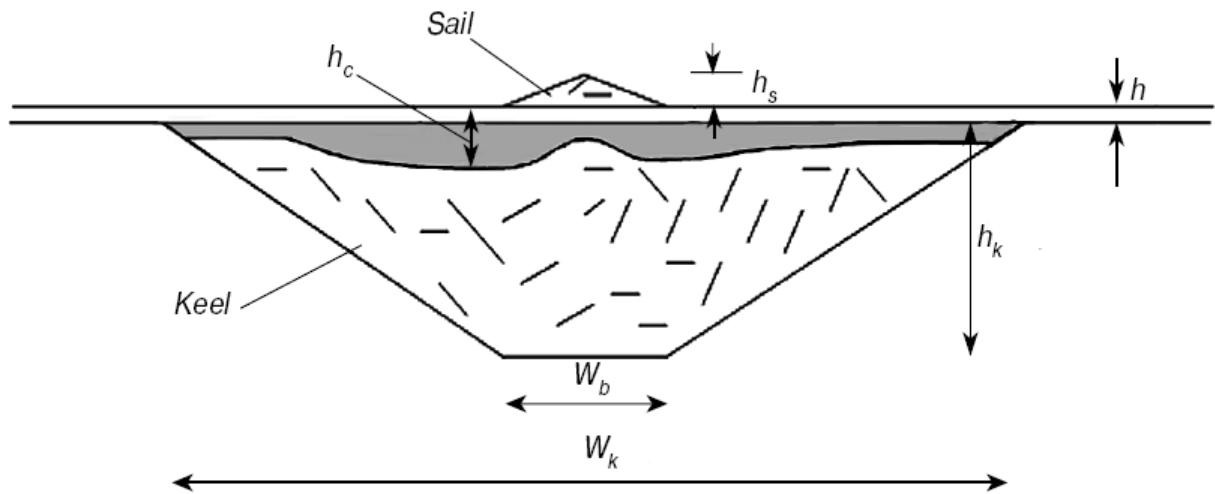

Figure 13 – Scheme of ice ridge configuration²¹

For estimation of the first-year sea ice ridge loads on offshore structures several methods have been proposed. The methods vary widely and depend upon the structure geometry (vertical or sloped) and the assumed failure mode of the ice. This project work considers the estimation of ice ridge loads on vertical structures. The load from each part of the ridge formation can be considered separately and the total ridge force can be assumed as their sum. It is also assumed that the failure of one ridge part does not influence the failure of the other two. One more assumption is that there is no temporal difference amongst the failure of each component of the ridge³².

The consolidated layer force can be approximately found by using the Korzhavin equation mentioned above.

For the sail and keel force prediction many models are proposed but only 3 of them are described in the work:

The first two are based on local ridge keel or sail failure modes and consider the failure of the ridge as a number of small local failures.

According to the Dolgoplov's theory based on some experiments the horizontal force can be estimated as³²:

$$F_h = h_k D_e q \left(\frac{h_k \gamma_e \eta^2}{2} + 2\eta c \right) \quad (14)$$

Where: h_k - keel depth, D_e - effective structure width, q – shape factor, γ_e - effective buoyancy, c - apparent cohesion of the ice rubble and η - passive pressure coefficient.

The passive pressure coefficient:

$$\eta = \sqrt{\frac{1+\sin\phi}{1-\sin\phi}} \approx \tan(45^\circ + \frac{\phi}{2}) \eta = \sqrt{\frac{1+\sin\phi}{1-\sin\phi}} \approx \tan(45^\circ + \frac{\phi}{2}) \quad (14.1)$$

The factor q depends on the depth of the keel and the structure width:

$$q = 1 + \frac{2h_k}{3D_e} \quad q = 1 + \frac{2h_k}{3D_e} \quad (14.2)$$

The effective buoyancy:

$$\gamma_e = (\rho_w - \rho_i)g(1-n) \quad \gamma_e = (\rho_w - \rho_i)g(1-n) \quad (14.3)$$

Where: n - void ratio (porosity).

In the Mellor's theory (1980) the rubble in the keel and sail slip along planes. The total horizontal ice force is found as the sum of the forces created by the ridge sail $F_{h,s}$ and the ridge keel $F_{h,k}$ ³²:

$$F_h = F_{h,k} + F_{h,s} \quad F_h = F_{h,k} + F_{h,s} \quad (15)$$

Each force can be found by using the following equation:

$$F_{h,s} = 0.5D_e\eta^2(1-n)\rho_i gh_s^2 + 2D_e c\eta h_s \quad F_{h,s} = 0.5D_e\eta^2(1-n)\rho_i gh_s^2 + 2D_e c\eta h_s \quad (15.1)$$

$$F_{h,k} = 0.5D_e\eta^2(1-n)(\rho_w - \rho_i)gh_k^2 + 2D_e c\eta h_k \quad F_{h,k} = 0.5D_e\eta^2(1-n)(\rho_w - \rho_i)gh_k^2 + 2D_e c\eta h_k \quad (15.2)$$

The third one is the Croasdale's theory that considers a global failure of the ice ridge. The ridge keel is assumed to fail as a plug bounded by two vertical failure planes, which initiate at the structure's sides, and a horizontal failure plane which is at the underside of the consolidated layer. In this theory the ridge force does not depend on the width of the structure or apparent cohesion. The force can be found as³²:

$$F_h = \frac{2}{3}W_R h_k^2 (\rho_w - \rho_i)g \tan\phi \quad F_h = \frac{2}{3}W_R h_k^2 (\rho_w - \rho_i)g \tan\phi \quad (16)$$

Where: W_R - width of the ridge, h_k - maximum height of the triangular keel, ϕ - angle of internal friction.

12. FIELD DEVELOPMENT



12.1. EXISTING EXPERIENCE

The development of the Dolginskoye field can be based on the Prirazlomnoye field project.

The Prirazlomnoye oil field is developed by one OIRFP positioned in the centre of the field. Platform has drilling and production facilities and equipment that enables to do all operations from drilling to processing phases.

At the Prirazlomnaya platform there are 40 slots for drilling wells of the following three types :

- 19 production wells
- 16 wells for water injection
- 1 well for injection of drilling cuttings
- Four remaining slots are for backup wells.

The planned well pattern at the field is shown in Figure 14.

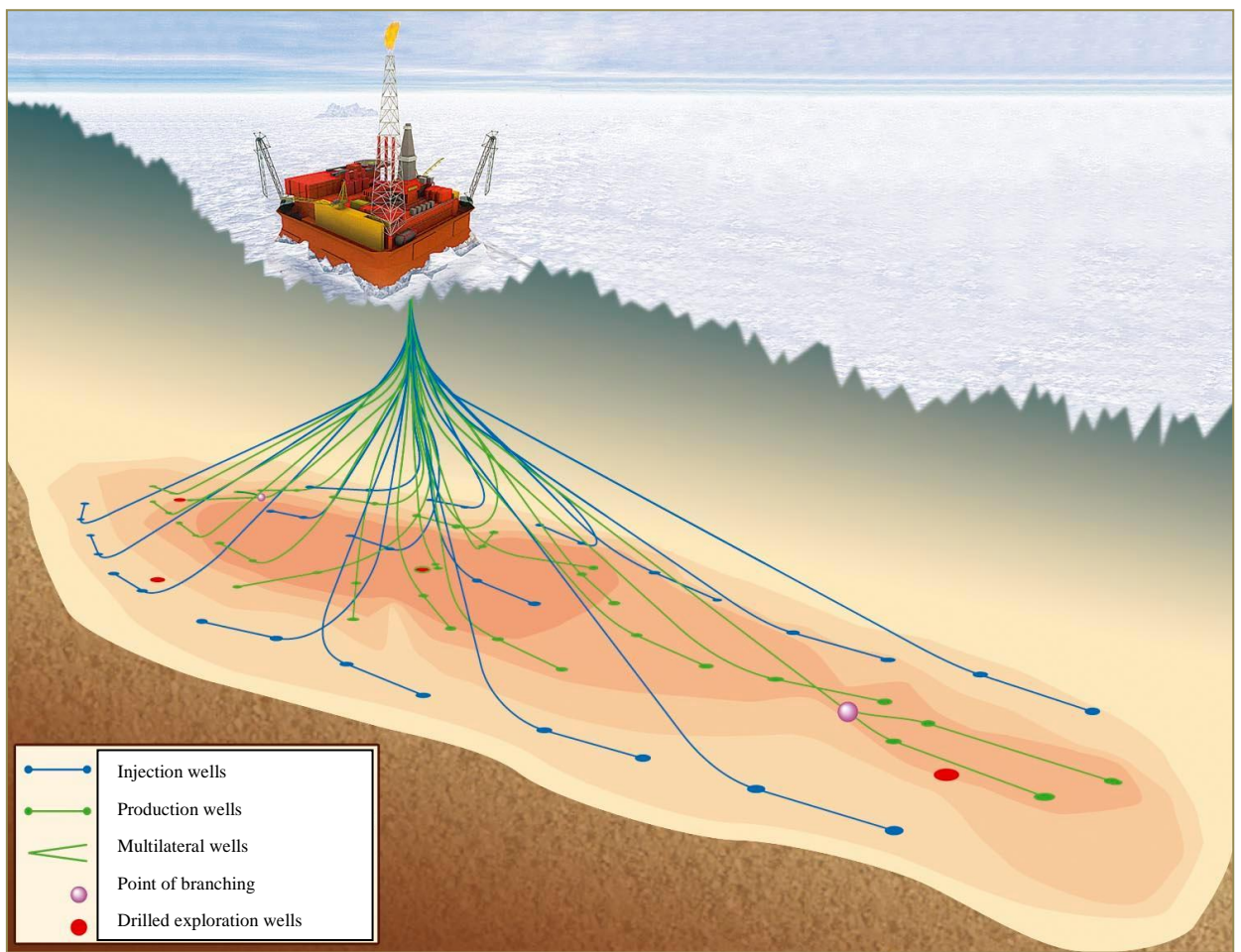

Figure 14 – Well pattern at the Prirazlomnoye field³³

³³ Gazprom нефть шельф. 2011. Development of the Prirazlomnoye oil field. Report of CEO at the conference “Euro-Arctic 2011”. ООО «Газпром нефть шельф». 2011. Обустройство и освоение приразломного нефтяного месторождения. Доклад генерального директора на конференции «Евро-Арктика-2011»

As you can see in Figure 14, there is slant, horizontal and even multilateral wells to be drilled. An average TVD (Total vertical depth) of the wells is 2500 m; an average length of the wells along the axis – 4700 m. The length of the well’s horizontal sections is 600-1100 m³⁴.

However, the Prirazlomnoye and Dolginskoye projects can have significant differences because of several reasons listed below:

- **Water depth:**

The location at the Dolginskoye field is twice deeper (around 40 m at the North-Doldinskaya structure) than at the Prirazlomnoye field. Therefore, in case of fixed structures application they should be higher. Their detailed description is represented in Chapter 13.

- **Field layout:**

As was mentioned in Chapter 10, the field has a length of approximately 75-90 kilometers. Despite that it is divided into two structures, North-Dolginskaya and South-Dolginskaya, and the field development is to be started from the North-Dolginskaya structure, the length of the field is still significant (from several to few dozens kilometers at different horizons)²⁰. Therefore, drilling wells from one platform (as at the Prirazlomnoye field) is non-efficient. The possible well pattern at the Dolginskoye field can be similar to the pattern at the Statfjord field in Norway [Fig. 15].

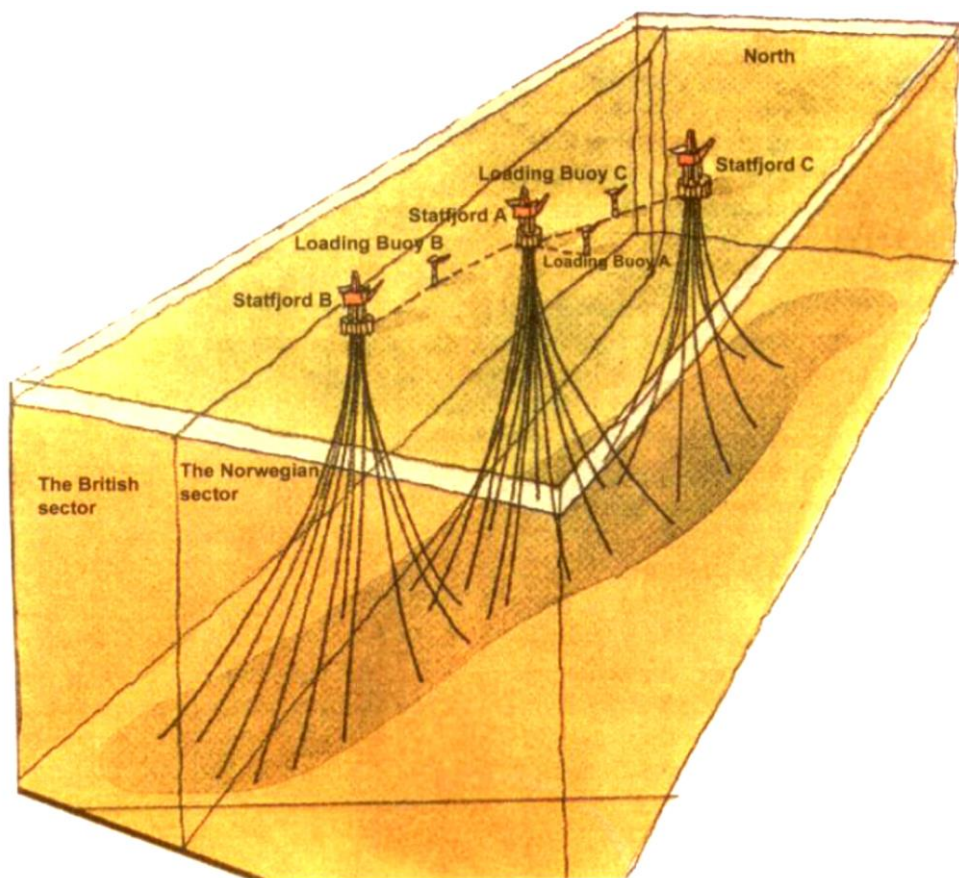

Figure 15 – Development layout of the Statfjord field⁸

³⁴ Info Step. 2012. Available from: www.info-step.com. (read 25.05.2014)

The geometries of these two fields are almost the same. As you can see from the picture, by drilling wells from three platforms the well pattern covers almost the whole field. Thus, a similar number of platforms is proposed as one scenario for the Dolginskoye field development.

12.2. FIELD DEVELOPMENT CHARACTERISTICS

According to the source from 2008, estimated characteristics of the Dolginskoye field development and planned number of wells of each type are represented in Table 6.

Table 6 - Dolginskoye field development characteristics²⁰

Planned production level	
- oil, TTOE	6690,7
- gas, mln.m3	314.5
Planned liquid production level, thousand tonnes	8700
Planned water injection level, thousand m3	10800
Number of wells	91
Production wells	68
including horizontal	0
Injection wells	23
including horizontal	0
Cumulative production	
- oil, MTOE	121,3
- liquid, mln. tonnes	257,2
Cumulative water injection, mln.m3	297,2
Oil Recovery Factor	0,309
Final water cut, %	88,7

12.3. FIELD DEVELOPMENT SCENARIOS

Possible field development scenarios are shown in Figure 16.

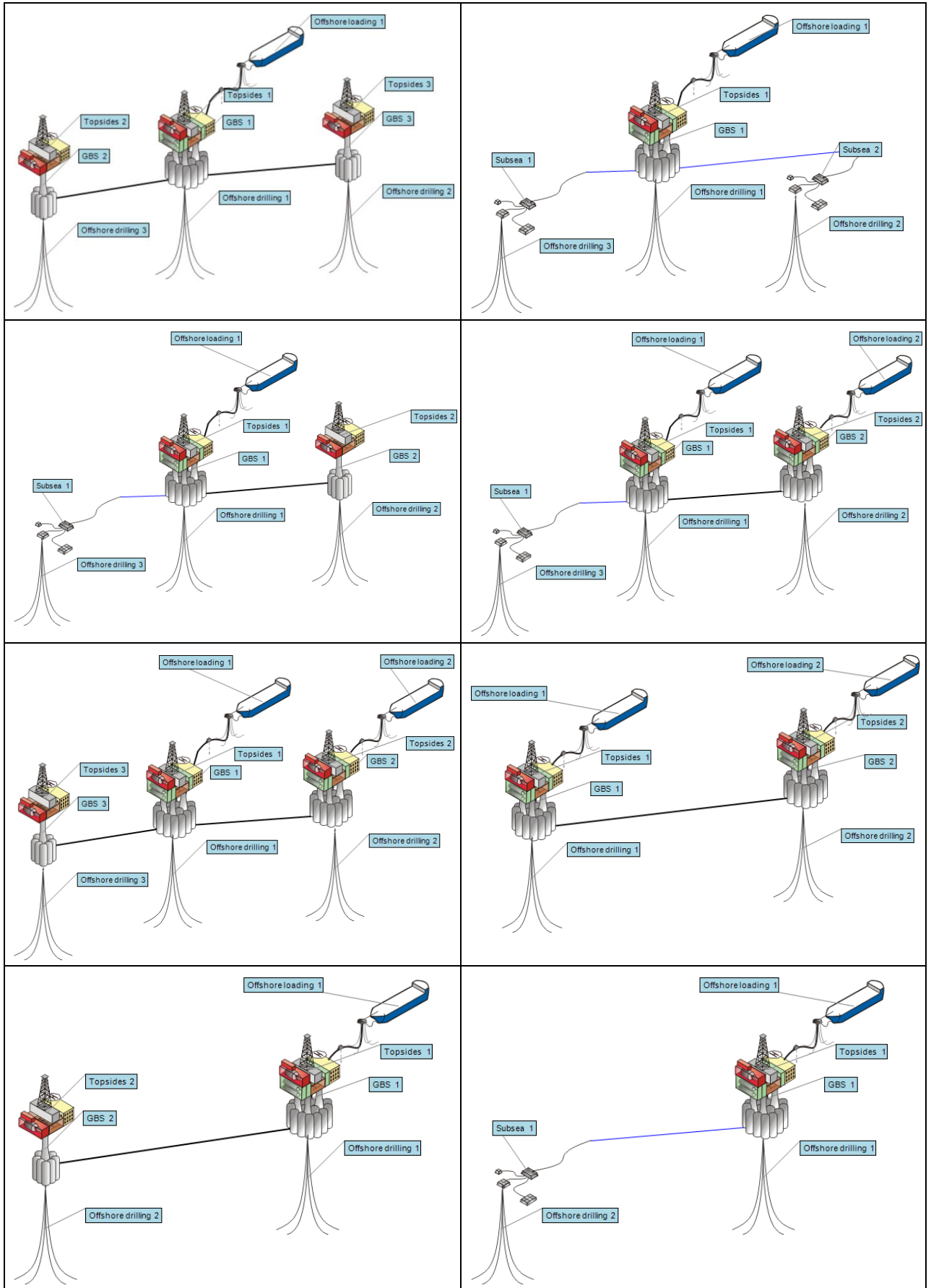

Figure 16 – Development scenarios of the Dolginskoye field (images made in Questor 10.1. The types of the structures used in the Figure show only that the concepts for platforms are GBSs, the bigger one is the host platform, the smaller one is a wellhead platform. A detailed description of the concepts is presented in the next chapter)

The first five scenarios imply drilling wells from 3 drilling centers. Proposed structures for these scenarios are:

- Host (technological) platform;
- Wellhead platform;
- Subsea templates.

The last three scenarios imply 2 drilling centers. One of these scenarios can be chosen in order to reduce CAPEX and OPEX if it is necessary. Proposed structures for these scenarios are the same as for the first group of scenarios.

An economic analysis of two scenarios (one of each group) is performed in Chapter 14.

Usage of wellhead platforms is possible at one or two corners of the geological structure as an additional facility (facilities) to the host platform. The possible designs of the platform types mentioned above are described in Chapter 13.

The total number of wells will be distributed between all drilling centers depending on the well pattern.

According to the Table 6, drilling horizontal wells was not planned at the time when the estimation was performed. However, based on experience of other offshore projects and taking into account the length of the field, in this report it is proposed to consider use the horizontal, slant and multilateral wells in order to cover the maximum part of the field by the well pattern that will enable to develop the field more effectively. Reduction of the total number of wells can also be considered as the way to reduce CAPEX of the project.

Table 6 also shows that in the field it is planned to drill 23 injection wells for water flooding.

Since it is planned to produce gas (around 300 mln. m³/year at peak), the part of the gas can be used for platform needs, while the other part can be injected back into the reservoir. In this case, one or two wells for gas injection possibly can be added to the total number of the wells.

There are some artificial methods that can be applied in order to maintain the pressure in the reservoir and enhance oil recovery. They are water injection and gas injection with possible adding of some chemicals. In case of sufficient gas recovery, the combination of water and gas injection, co called Water-alternating-gas (WAG) method where gas injected as a supplement to water or vice versa, is also possible. As a pressure maintenance method, the gaslift can be used.

12.4. SUBSEA TEMPLATES

Subsea templates can be installed at one or two corners of the North-Dolginskaya structure at water depth of around 40 m.

Such templates can also be used to develop satellite fields, for example, the South-Dolginskaya structure. The number of templates and their types depend on how many wells are planned to be drilled from the drilling center where they are installed. At the South-Dolginskaya structure use of templates can be problematic because of ice ridges.

With reference to the chapter “Environmental conditions of the Pechora Sea”, the water depth in the field location varies from 20-25 m in South-East part to 40-45 m in North-West part. The first part has flat bench-like surface, while the second is slightly sloped in North-West direction. Ice ridges in the Pechora Sea can have a keel draught (h_k) up to 12-18 m. Stamuchas (grounded ridges) are usually located at 7-15 m water depth. They were not observed at more than 20 m water depth.

According to this data, installation of subsea templates at the South-East part is not safe. The following procedure can be used to avoid it:

- 1) Choose the deepest possible installation place
- 2) Make a glory hole(s) to embed the template(s): digging glory holes can be challenged because of the hardness of sea-bottom. With reference to the chapter 3.2. Soil conditions, in the area of the Dolginskoye field the sea bottom sediments are classified as hard sediments consisting of sand or muddy sand.

Open conical-shape glory holes can be approximately 10 m deep and around 20 m in diameter. Making the holes can be executed with help of the trailer suction dredging technology firstly applied at the Terra Nova field. The largest hole at that field is 65x25 meters that was the largest excavation in the seabed had ever been done at that time (2002). The top of the wellheads at the Terra Nova field is situated about 3 m below the mud line. This technology was firstly used to protect the wellheads from scouring a seabottom by icebergs. The technology very seldom has been used; only at fields like the Terra Nova and the White Rose.

Each template is designed for several wells with vertical or horizontal X-mas trees and a manifold. The manifolds are connected to the risers by flexible flowlines. For such shallow waters all the wells should have the horizontal X-mas trees because of the following reasons:

- It has less size compared to vertical trees which is very important for the installation of Xmas trees in glory holes
- The application of horizontal trees was more efficient. As we are in shallow water it does not take much time to pull the tree down to the seabed, and we do not need to do it twice as in case of vertical trees

- 3) Install some structure to protect subsea wells from ice ridges: this solution can be expensive and requires detailed economic analysis.

The subsea template is a part of the Gathering and Distribution system that includes flowline network and process facilities used to transport hydrocarbon flow from subsea well trees to a main offshore facility, where the fluids can be stored and processed.

The system consists of the following main parts:

Table 7 – Gathering and Distribution system elements³⁵

Description	Purpose
Foundation	Provides an anchor and level platform for the subsea equipment to rest on.
Template	The Template is a structural foundation in which the Manifold and Xmas Trees are positioned. The purpose of the Template is to direct/positioning the drilling activities, to protect Manifold and Xmas Tree from trawling activities and dropped objects.
Manifold	The Manifold gathers the produced fluids/gas from the Xmas Trees and distributes it through flowlines towards the processing facility. It also distributes injected fluids (gas or water) or gaslift gas to individual wells.
Termination Structures & Tees	The Termination Structures and Tees are providing gathering, distribution and end termination for the Flowlines, Umbilicals and Pipelines.
Connection Points	Connect flowlines and/or subsea facilities together.

For the Dolginskoye field the templates with 4, 6 or 8 slots are applicable. The number templates and the number of slots in each template depend on the total number of wells, the cost and complexity of installations, and other factors.

A typical example of 4-well manifold template with integrated foundation system is represented in Figure 17. The description of the elements of this template is given in Table 8.

³⁵ Gathering and Distribution system. Available from: www.Subsea 1.com. (read 11.04.2014)

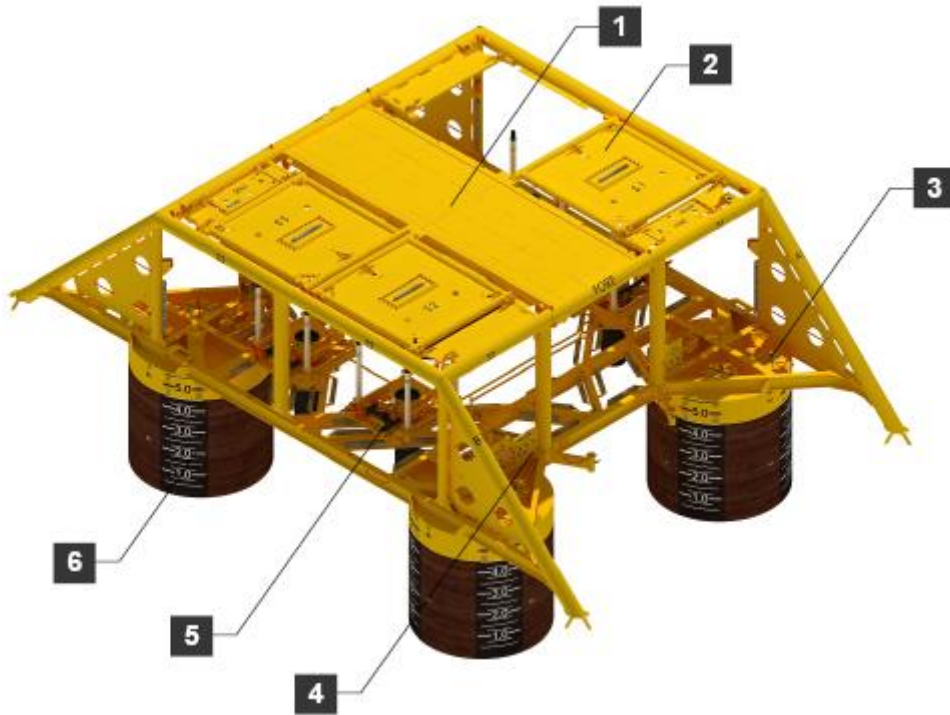

Figure 17 – 4-well manifold template³⁵

Table 8 – Elements of the 4-well template³⁵

Pos. no.	Description	Purpose
1	Temporary Protection Cover	To protect the Template temporarily against impacts from trawling activity prior to installation of the manifold
2	Wellbay Hatches	To protect against impacts from trawling activity and dropped objects
3	Ventilation Hatches	To decrease added mass and washout during seabed penetrations
4	Suction and Grout System	Contingency support for the foundation system
5	Wellbay Inserts (also called Permanent Guide Base) incl. Guide Posts	To support Xmas Tree
6	Foundation System	Provides an anchor as well as a stable platform for the subsea equipment to rest on

Template functions³⁵

The template is aimed to provide support for subsea equipment such as:

- Subsea Wellheads and Xmas Trees;
- Piping Manifolds (for production, injection, well testing and/or Chemical Distribution Systems);
- Control system components, e.g. Subsea Control Modules, hydraulic piping, electrical Cabling;
- Drilling and completion equipment;
- Pipeline pull-in and connection equipment;
- Production Risers.

In addition it has a frame to protect subsea equipment from impact damage caused by dropped objects or fishing equipment.

The function of the template will vary with location, installation methods, pipeline methods (horizontal or vertical flowline connection, pipeline forces), protection requirements (fishing gear protection, protection from dropped objects, etc.), drilling methods (suction of drill cuttings, cement suction, drill cutting injection, etc.) and other conditions.

The most important design criteria for templates are the following:

- Physical Interfaces to Xmas Tree, Manifold and Guide Base/Well Bay Insert;
- Instrumentation requirements;
- Materials;
- Corrosion protection (internal and external);
- ROV interfaces;
- Design life.

Template installation³⁵

There are several template installation methods:

- moonpool
- drillpipe
- crane vessel
- modular
- barge or wet tow

A Crane is lifting and lowering the complete assembly down to correct position from a crane vessel. For correct positioning of the Template, acoustic sensors are used. There are several solutions for Template, Foundation structure and protection structures, one solution is a combined Template and foundation structure including Well bay inserts/Guide Bases for guiding and installation of multiple Xmas Trees. In this solution the Manifold is pre-installed on the Template before installation subsea.

12.5. OFFLOADING SCENARIOS

There are two main offloading ways, either to offload the oil to shuttle tankers or to pipelines going to shore.

1) Shuttle tankers



Figure 18 – First offloading scenario (to shuttle tankers)³⁶

The tankers can be similar to those used at the Prirazlomnoye field. At the field there are two shuttle tankers with the following characteristics:

Shuttle tanker «Mikhail Uljanov»³⁶ [Fig. 19]:

- deadweight – 70 000 t;
- gross tonnage – 49 866 t;
- speed – 16 knots;
- total length – 257.00 m., width – 34.00 m.;
- board height – 21.00 m.;
- draught – 13.60 m.;
- level of fuel consumption per day – 38 t.

Shuttle tanker «Kirill Lavrov»:

³⁶«Gazprom neft shelf» LLC. Official website. Available from: www.shelf-neft.gazprom.ru (read 19.02.2014)

The characteristics are the same as for shuttle tanker «Mikhail Uljanov»



Figure 19 – Shuttle tanker “Mikhail Uljanov” used for transportation of oil from the Prirazlomnaya field³⁶

2) Pipeline to shore

Having this method the oil can be transported to the Prirazlomnaya platform and offloaded then to the local tankers. In addition, the oil from subsea modules or wellhead platforms will be pumped to the host facility through the subsea flowlines.

12.6. SUPPORT VESSELS

In case of having the technological platform at the field we should provide the unit with several support vessels during the whole life period of the field. Taking into account the water depth about 40 meters at the area we can use a similar support system as at the Prirazlomnaya platform or modify it according to field specifications.

The support system of the Prirazlomnaya platform includes ice-breakers «Vladislav Strejov» and «Yury Topchev». The first ice-breaker is shown in Figure 20.



Figure 20 – Ice-breaker used at the Prirazlomnoye field³⁶

13. DESIGN OF THE PLATFORMS



13.1. EXISTING EXPERIENCE

It is still a big challenge to design a GBS for the Arctic continental shelf, but there are some successful examples.

For example, we refer to the Prirazlomnaya Ice-Resistant oil-producing platform that has been installed on the Russian Arctic shelf. The platform currently operates at the Prirazlomnoye oilfield. The field is located south of Novaya Zemlya in northern Russia on the Pechora sea shelf (South-East part of the Barents Sea) at a distance of about 60 km from the shore. The water depth in the area is about 19 m to 20 m. This Arctic region is characterized by extremely low temperatures and strong ice loads. It is ice-free for 110 days a year and the cold period lasts 230 days. Ice thickness could reach the value of 1.7 m. The annual average temperature is -4 °C and the temperature minimum is -50 °C. Wind speed can be up to 40 m/s and wave heights up to 12 m.³⁷

The Prirazlomnaya oil platform has the size of 126x126 m across the foundation. Its weight is about 113000 tonnes without the solid ballast and 506000 tonnes with it. The Platform is reliably held on the sea bottom due to its own weight and is protected from scour by rock rubble berm. The structure is made of steel frame with concrete inside. The platform has sloping walls (Ice and Wave deflectors) in order to reduce the loads. The platform has the total oil storage capacity of 109 000 TOE (124 000 m³). The platform will ensure well drilling, oil production, storage and offloading. Its main advantages are resistance to strong ice loads, long self-sustainability and year-round operability³⁶. The owner of the field is a company «Gazprom нефть shelf». Oil production at the Prirazlomnoye field has been started from the end of 2013.

The other bright example is the Varandey Oil Export Terminal (VOET), which is used to export LUKOIL's crude produced in the Timan-Pechora oil and gas province by sea. The terminal is situated in the coastal zone of the Barents Sea at the distance of 22 km from the shore. Two subsea pipelines transfer oil from the onshore storage tanks to the Fixed Ice-Resistant Offshore Export Terminal (FOIROT). This is the world's northernmost offshore terminal. The operations are supported by three 70,000 tons DWT ice-breaking tankers, especially built to operate in the region. The terminal's annual offloading capacity is 12 million tons of crude³⁸.

The realization of these two projects based on the experience obtained by many offshore fields developed with application of GBS and facilities of other types. **The schemes of the projects with a brief description are represented in Appendices 3 and 4.**

³⁷ Prirazlomnoye Oil field - Russia. Available from: <http://www.offshore-technology.com/projects/prirazlomnoye/>. (read 17.03.2014)

³⁸ Lukoil's Varandey Terminal: one year of successful operation on the Russian Arctic Shelf. Press-release 2009. Available from: http://www.lukoil.com/press.asp?div_id=1&id=3077. (read 17.03.2014)

13.2. GENERAL ICE-RESISTANT GBS DESIGN PRINCIPLES

After analyzing the structure features as well as taking into account the specifics of the Arctic region several concepts for an Ice-Resistant Fixed Platform were suggested.

In general the concept for an Ice-Resistant GBS should have the following features:

- ✓ It should be made of strength material such as steel, reinforced concrete or the combination of these two (steel frame filled up with concrete);
- ✓ The structure geometry can vary from conical shape to rectangular;
- ✓ If the ice conditions are severe, the hull of the structure should have sloping walls to reduce ice loads, but in some cases the vertical walls are still applicable. The sloping angle can be different, depending on the structure design and the conditions, in which it will be used. For each angle we can calculate the horizontal and vertical load acting on the structure due to the ice drift [see Appendices 1 and 2]
- ✓ Analyzing the calculations we can conclude that the structure with a less steep sloping angle will have a less ice load [see Appendices 1 and 2]. However, the foundation size for the structure with a slightly sloping angle might be too large and its fabrication could be inefficient;
- ✓ The facility can have the length (or diameter) of more than 100 m and its application is limited by approximately 100 m water depth due to economic reasons;
- ✓ The mass can have a wide range (10-100 thousand tonnes and more) depending on size, fabrication material, wall thickness, storage capacity, sea bottom hardness, etc.;
- ✓ The structure can be kept in place due to its own weight. In order to provide reliable on-bottom stability and to prevent erosion of sea bottom soils, a special rock berm can be built around the structure.

Table 9 shows possible types of GBS or pile-type structures for shallow waters and terms of their application.

Table 9 – Offshore GBS or pile-type structures for shallow waters and terms of their application²⁹

	Sea depth	Terms of application	Loading specific features	Note
Caisson	Less than 30 m	Superstructure weight > 30000t. Presence of oil storage. Large amount of wells (>50)	The wall is almost vertical (angle α with the horizon > 60°). Extreme global ice load (4+5 MN per one linear meter) exceeds wave load. The effect of ice and wave impacts on soil foundation is comparable due to wave dynamic effect.	Gravity type, possibly with soil core.
Monocone	Up to 50 m	Superstructure weight 15000+30000t. Large amount of wells up to 50.	The wall is inclined 45°> α >60°. The values of extreme global and wave loads are comparable. Due to slamming, the integrated deck must be considerably elevated above MSL.	Gravity or pile type. In pile type alternative, there may be a need for float installation of superstructure (integrated floating deck) on preliminary anchored substructure.
Multi-column -(2-4 columns)	Up to 50 m	- " -	Column walls are vertical or inclined in MSL zone. The values of extreme global wave load is less than ice load. The ice load may be considerable, especially for depths less than 20 m. Integrated deck slightly elevated above MSL.	- " -
Truss type	Up to 30 m	Superstructure weight < 2000 t. Number of wells < 20.	Ice load surpassing wave load.	Pile type. Problem of transportation to site.

13.3. POSSIBLE CONCEPTS

There are several concepts for the structures to be designed for the Dolginskoye field. It is suggested that GBSs will be chosen as the most efficient concept for such depth, environmental conditions and functional requirements. The possible structure types and their functional requirements are described in this chapter.

Monocone (one-column) and multi-column structures

With reference to the previous Chapter, in several field development scenarios for the Dolginskoye field it is suggested to implement one/two monocone (one-column) GBSs in combination with one/two multi-column platform [Fig. 21].

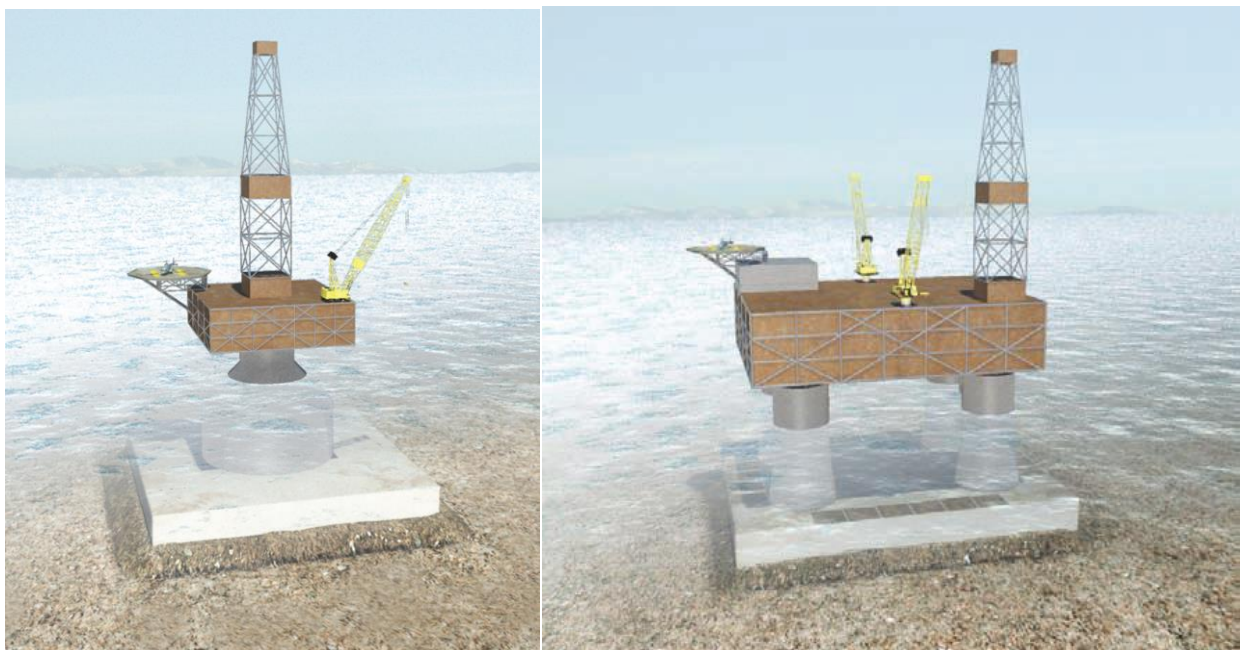

Figure 21 – Concepts for GBSs for the Dolginskoye oil field: monocone (one-column) GBS (left) and multi-column GBS (right)³⁹

The monocone structure can have functions of wellhead platform. These functions are the following:

- Drilling wells;
- Injecting water/gas and chemicals;
- Transporting hydrocarbons to the host facility.

Since it is not designed for storage, processing and offloading purposes, the size of the platform should be less than the size of the host platform. Therefore, the mono-cone structure type is applicable. Moreover, the chosen concept meets the requirements described in Table 5 as the

³⁹ Engineering Services. Arctic Capability Statement. Available from: www.arup.com (read 19.03.2014)

depth is less than 50 m, the weight of the facility should not exceed 30000 t and the number of wells should not exceed 50 (the wells in this concept are located at both wellhead and host platform (platforms)).

Multi-column structure can be applied as the host facility. In this design the topsides are supported by two, three or four columns. The number of the columns depends on the number of required modules, topsides dimensions and their weight. Figure 21 represents the four-leg concept.

Structures of such type have been successfully exploiting at some other fields in the Arctic or Subarctic regions. The bright example is the Lunskeye A 4-column fixed platform used in Sakhalin II project. The columns are made of concrete; they have cylindrical shape and are able to resist the ice loads. However, the ice conditions of Arctic regions are more severe; therefore it might be necessary to develop a new design of the platforms' columns for the Dolginskoye field shown in Figure 22. This implies making columns with ice deflectors having sloping walls at the MVL (mean water level). These deflectors will significantly reduce ice loads on each column and vibration caused by ice drift and failure.

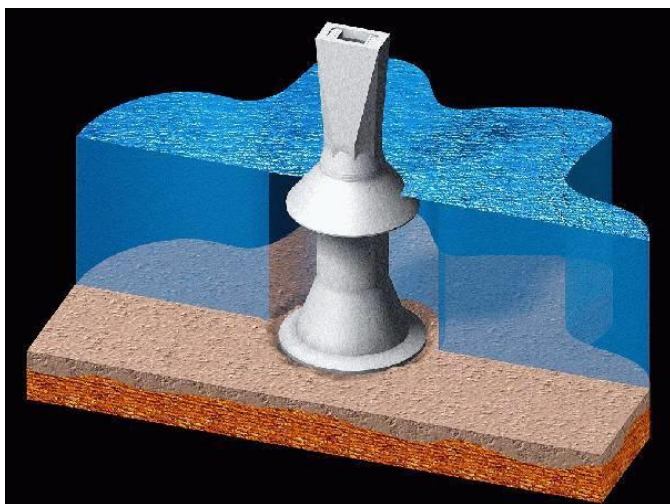
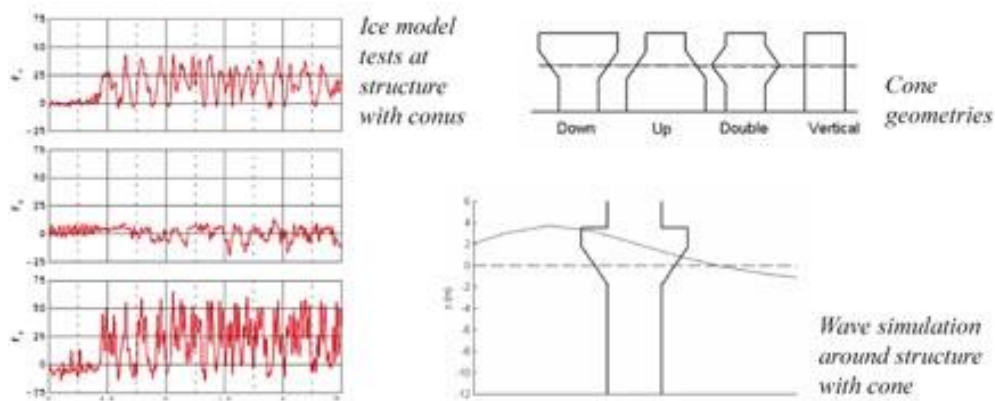

Figure 22 – Design of columns for the Dolginskoye field platforms (presented concept has been designed for bridges over rivers; in order to implement it at offshore platforms much wider base is necessary to resist loads)

The diameter of each column should be enough to place the planned number of well slots inside and at the same time the column of such diameter should provide good resistance against environmental loads and safely support the structure.

For example, in the column with diameter of 20 m it is possible to place up to 19 slots⁴⁰. But additional space (like free space in other columns) is necessary to keep additional equipment.

So, in case of installation of 3 platforms at the field, each platform should have around 30 slots as the total planned number of the field is about 90. The application of only two platforms at the field, one host platform and one wellhead platform, would require around 60 well slots at the host platform and around 30 at wellhead platform. In this case, the host platform should have at least 3 columns (30 well slots in each of the two drilling columns, 2 drilling rigs are needed, one column for additional equipment). For both cases, the reduction of the total number of wells can also be considered.

Caisson-type structure

As the site of installation of the platforms is shallow (around 40 m depth) the caisson-type GBSs are also applicable. Figure 23 shows various designs of the caisson-type structures that can be installed at the water depth of up to 50 m.

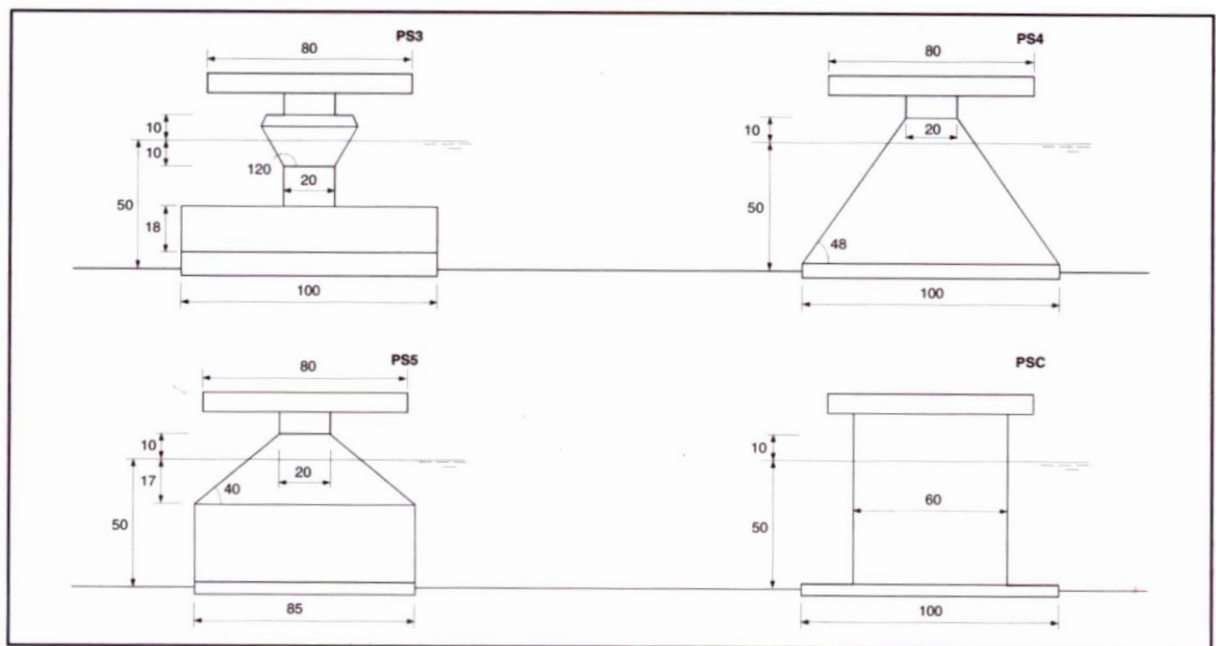

Figure 23 – Hull geometry for the caisson-type structures at 50 m water depth⁸

The main advantage of this concept is larger storage volume. For example, the storage volume of the platforms shown in Figure 23 could be up to 280 000 m³.

⁴⁰Musabirov A.A. 2013. Development and studies of application of new Ice-resistant Platform design for shallow water Arctic shelf. Report. Moscow. Мусаби́ров А. А. Разработка и исследование применимости новой конструкции ледостойких платформ на мелководном Арктическом шельфе. Доклад, Москва 2013

On the caisson-type platform the number of wells can be 40 (as at the Prirazlomnaya platform) and more (depending on the size and functional requirements). Therefore, scenario with one caisson-type platform and one wellhead platform or two caisson-type platforms can also be possible.

13.4. TOPSIDE

Possible configuration of topside for multi-column platforms is shown in Figure 24.

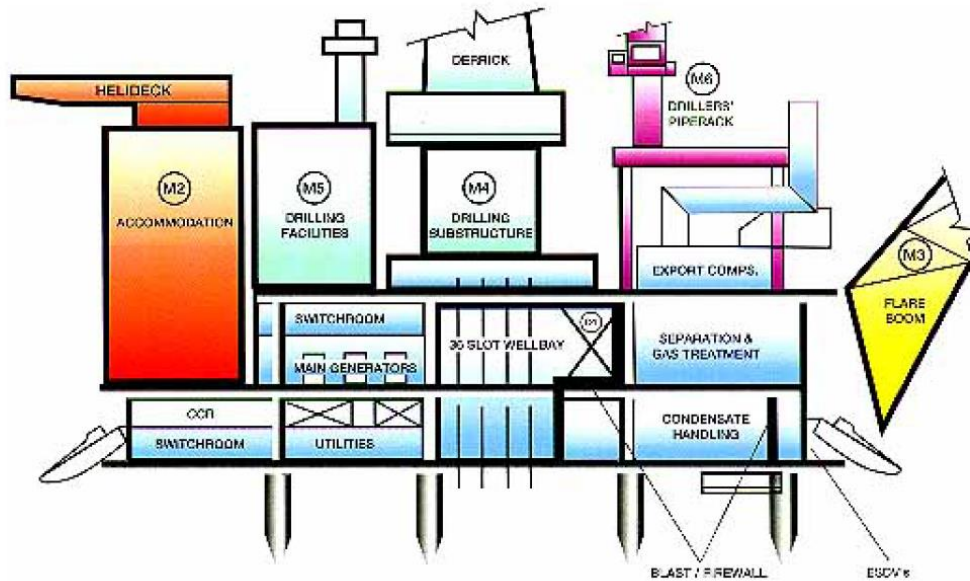

Figure 24 – Configuration of topside for multi-column platform⁴¹

The topside for monocone platform that has the functions of wellhead platform are almost the same excluding Processing module as the oil, gas and water will be transported from the wellhead platform (platforms) to the host facility.

For the caisson type structure the configuration of topside could be similar to that at the Prirazlomnaya platform [Fig. 25].

⁴¹Britannia, United Kingdom. Available from: <http://www.offshore-technology.com/projects/britannia/britannia3.html>. (read 25.05.2014)

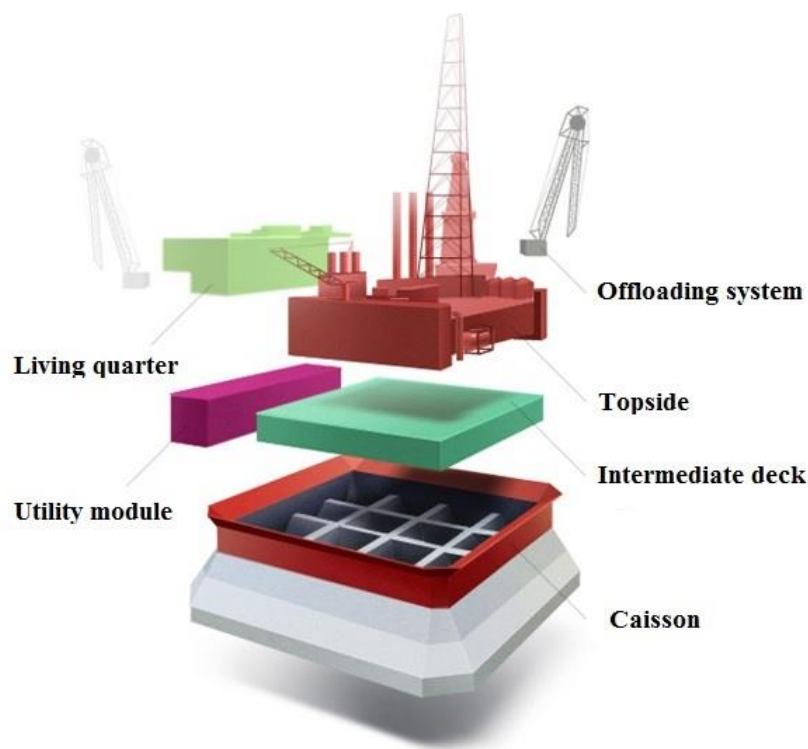

Figure 25 – Configuration of the Prirazlomnaya platform³⁶

13.5. OIL STORAGE SYSTEM

For the offshore storage a special wet storage system can be implemented. According to it the oil is stored at the upper part of the tank floating on the top of a sea water pillow. When the oil is injected into the tank, the sea water is displaced out of the storage tank. When the oil is taken off from the tank, the sea water replaces the empty volume again. There is an intermediate layer between two fluids that always exist as the oil penetrates the water column to a certain depth. This layer always exists in the tank and it's not displaced out of the tank according to environmental requirements.

The storage tanks of the Prirazlomnaya platform and its possible modernization for the Dolginskoye field host facility are shown in Figure 26.

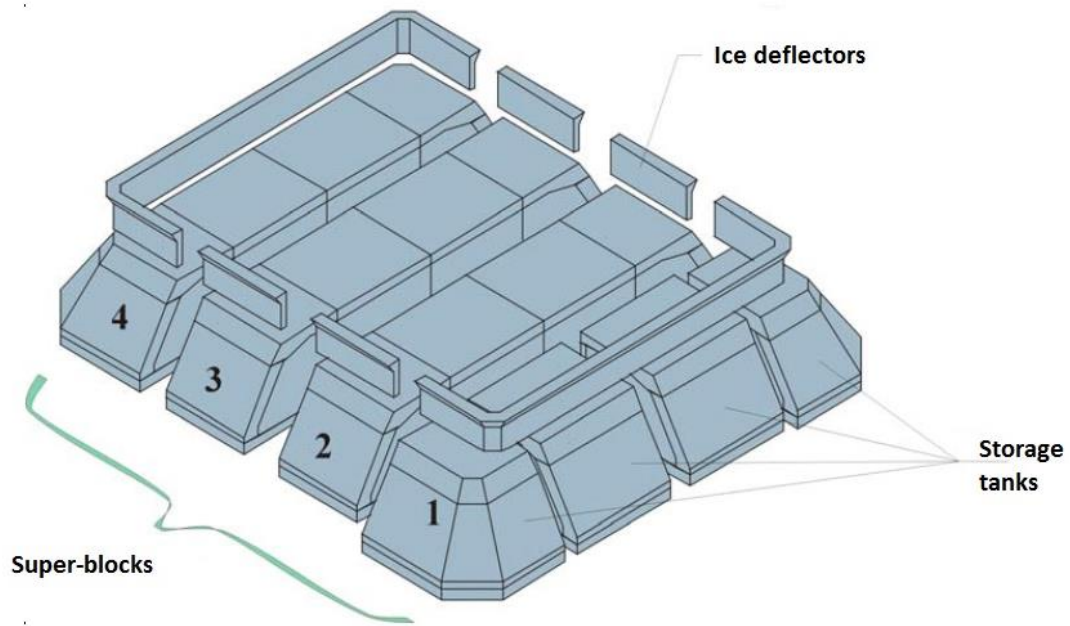

Figure 26 – Storage tanks of the Prirazlomnaya platform³⁶

13.6. OFFLOADING SYSTEM

In order to offload the oil from the storage tanks to the shuttle tankers, a special crane system (CUPON) is used at the Prirazlomnaya platform. The crane enables tankers to keep a necessary distance from the platform for the safety reasons. The system is shown in Figure 27.

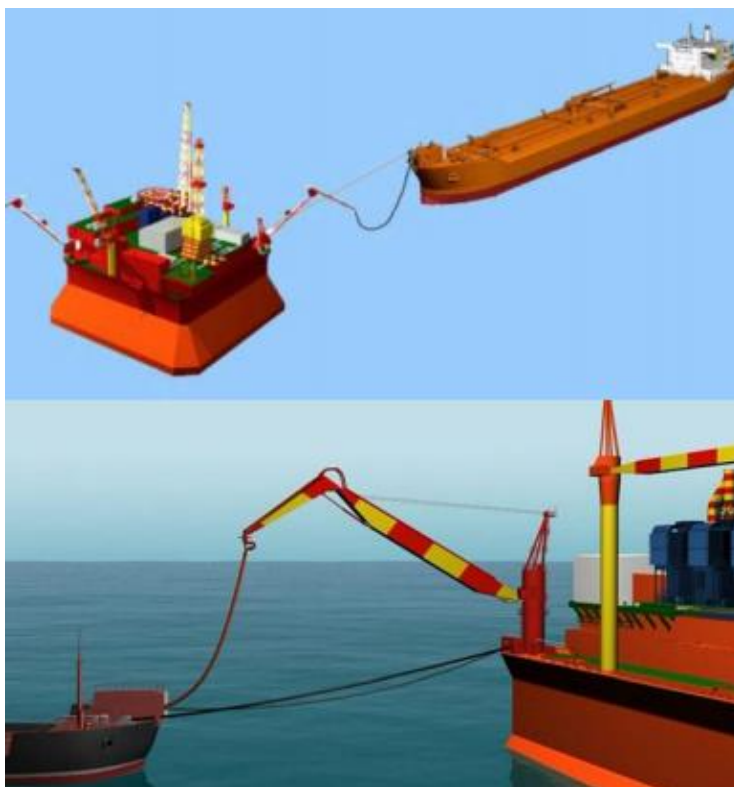

Figure 27 – Offloading system at the Prirazlomnaya platform³⁶

13.7. CONSTRUCTION AND INSTALLATION

Mail design aspects for construction of concrete offshore structures are⁴²:

- High stiffness, providing a stable foundation for tanks and other attachments
- Good resistance to environmental loading
- Excellent behavior at low temperatures
- Favorable in ice-infested waters
- Robust with respect to accidental loading such as ship impact, dropped objects or terrorist attacks
- Good resistance to oil and gas process hazards
- Functional and safety features common to a land based plant.
- Good resistance to cold spot incidents
- Enhanced material properties with decreasing temperature
- Excellent fatigue resistance
- Good durability, and basically maintenance-free
- Standard offshore concrete quality applied
- No need for skilled labor for the bulk of the construction work, enabling local execution
- Good resistance to seismic loading
- May be decommissioned and removed, possibly reused

For a caisson type platform the use of a steel-concrete sandwich structure is more technically feasible because of the following reasons:

- A steel outer structure provides the shape for the caisson
- Several smaller blocks can be welded together in a yard
- Making a full concrete caisson might be complicated because of the huge size of a caisson (especially for 40 m water depth). Instead the inner volume of the sandwich structure can be filled up with concrete. It allows to use less steel material during construction of the platform and make walls of the caisson thicker (up to 3 m as in the Prirazlomnaya platform's caisson)
- Concrete in a caisson plays the role of ballast during transportation of the platform to the site
- This method of fabrication was used before at the Sevmash yard, which is located in the Severodvinsk harbor, Russia. A new caisson for the Dolginskoye project could be constructed at the Sevmash yard in the same manner as for the Prirazlomnoye project

Figure 28 shows the configuration of the Prirazlomnaya platform walls.

⁴²Sandvik K., Eie R. and Advocaat J., of Aker Kvaerner Engineering & Technology AS. 2004. Offshore Structures – A new challenge. How can the experience from the marine concrete industry be utilized. XIV National Conference on Structural Engineering, Acapulco

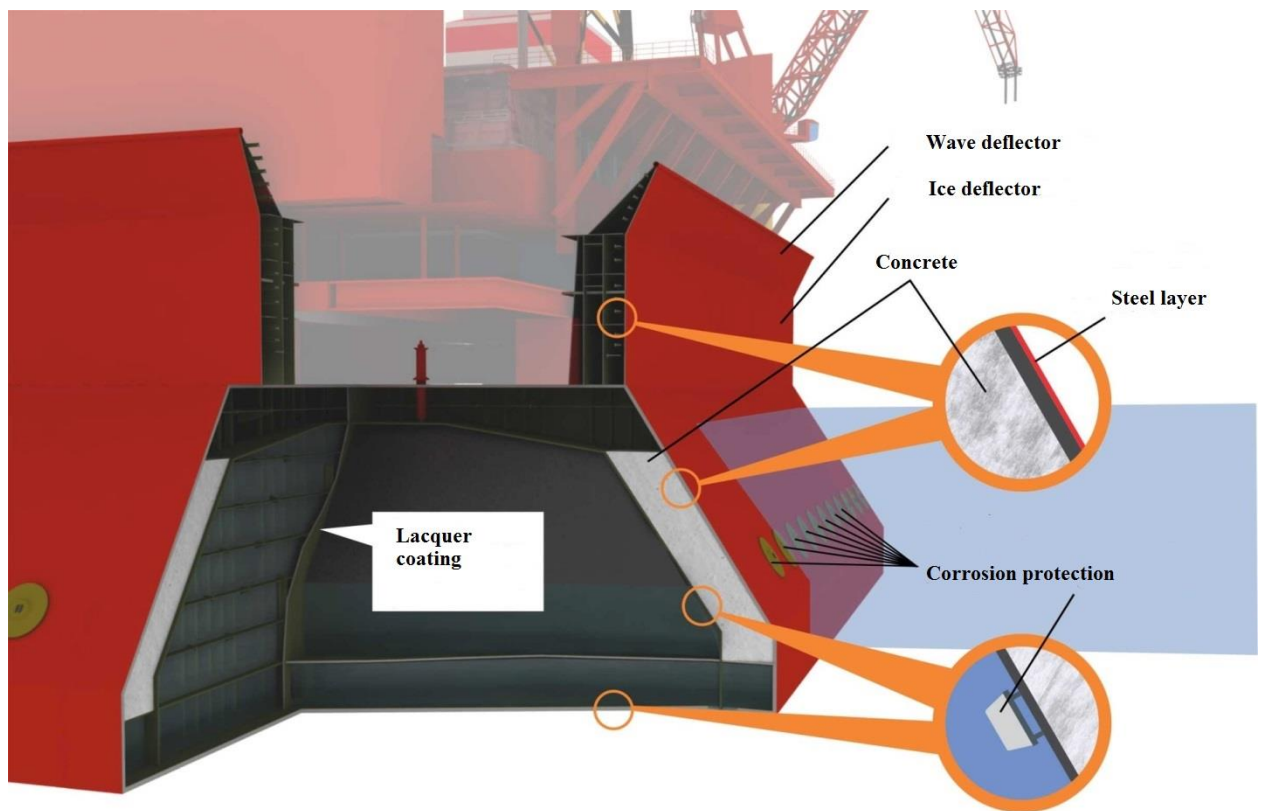

Figure 28 – Configuration of the Prirazlomnaya platform walls³⁶

As the structure is installed in the sea its outer walls fully covered with water. Therefore, a corrosion protection is necessary [Fig. 28].

For monocone and multicolumn structures the use of concrete as a construction material seems more appropriate since much less concrete is necessary than for a caisson.

A structure made of reinforced concrete has the following advantages:

- reduced cost for fabrication and installation comparing with a steel GBS
- availability of construction materials
- greater durability during operations
- low maintenance costs and the ability to fabricate good quality concrete elements at many locations
- reduced installation time due to on yard completion and transportation with all necessary equipment to the offshore site

In order to fabricate a concrete structure for the Dolginskoye field, a dry dock is required. There are two ways: either to use an available operating dry dock or to prepare a new dry dock site. Since the Russian Arctic region is now under development and several projects for the Pechora and Kara Sea development have already been planned, the preparation of such dry dock site close to Murmansk should be considered.

The development of the dry dock in Murmansk region has actually been discussed at the meeting of the governor of Murmansk region and representatives of “Aker Kvaerner”. A possible future location of the dock is the Teriberka village⁴³. However, the discussion continues as in order to realize this project, many requirements should be satisfied. These requirements are discussed below.

Development of a dry dock is a major expense in the construction of a concrete platform. This expense can include land procurement, excavation, cofferdam construction, dewatering systems, dredging of channels for float out, construction of supporting quays, docks and wharves, and the overall upgrading of the infrastructure to improve project support (roads, bridges, power supply, water supply, sewage treatment, etc.). These costs can reach up to 80 percent of the project cost in remote areas.

In general construction and installation of offshore facilities consist of the following stages⁴²:

- Detail design of dry dock and construction site taking water depth restrictions into account
- Detail design of concrete structure prior to concrete structure construction start
- Dry dock and construction site development
- Construction of lower part of concrete structure inside the dry dock
- Float out of dry dock and mooring at inshore wet construction
- Construction of upper part of the concrete structure at wet construction site
- Installation of topsides facilities and/or other type of outfitting
- Tow to installation site, positioning and installation at location

A medium size concrete platform built in concrete will require a fabrication dock with an area of some 140 x 140 m, and a water depth of 10-12 m. The concrete hull can be completed in the dock if a sufficient water depth is available, or it can be completed in a floating condition at a place outside the dry dock, with sufficient water depth.

It generally costs less to construct a GBS entirely in a dry dock rather than partially in the dry dock and partly at a wet dock or at a jetty mooring. Productivity is generally higher in the dry dock and specialized equipment is minimized. Construction risk is usually lower⁴⁴.

As the platforms for the Dolginskoye field should be designed for 40 m water depth, they might be built entirely in the dry dock with sufficient buoyancy to be floated out and towed to its final location.

General aspects for establishing a dry dock are listed in Table 10. Required infrastructure and equipment for fabrication offshore concrete structures are listed in Table 11.

⁴³ Garnat O. 2006. Perspectives for a dry dock construction. Journal “North industrial” #5. Гарнат О. 2006. Перспективы строительства сухого дока. Журнал “СЕВЕР промышленный” № 5. Available from: <http://helion-ltd.ru/buildingdrydock/>. (read 1.06.2014)

⁴⁴ Hoff G.C, Reusswig G., and Ugaz O.G., Mobil R&D Corp. 1993. Concrete GBS Platforms and Site Considerations for Southeast Asia: Structural Concepts. OTC 7160 (Offshore Technology Conference)

Table 10 – Establishing a new dry dock site preparation⁴⁵

<p><u>Site Preparation</u></p> <ul style="list-style-type: none">Clean and level siteExcavate/blast for dock basinEstablish sheet pile wallsEstablish various utilities (water, power, sewage, etc.)Establish jettyEstablish offices, camps, stores, etc.Start fabrication of mechanical items 2 months before work in dock.Order long-lead items 6 to 8 months before startup. <p><u>Approval</u></p> <p>Approvals from <i>all</i> authorities <i>must</i> be obtained before any work related to establishing the dry dock begins.</p> <p><u>Schedule</u></p> <p>(A 6- to 9-month period is needed from contract award until start construction in dock, depending on area/depth of dock.)</p> <p>Will blasting be necessary?</p> <p>Drainage is necessary where water penetrates the dock.</p> <p>Slab is necessary if the bottom consists of very soft materials.</p> <p>For sandy soils, the time to establish the dock is short, but we need a considerable drainage system.</p>

Table 11 – Infrastructure and equipment for fabrication concrete structures⁴⁵

<p><u>Infrastructure</u></p> <ul style="list-style-type: none">Labor campAccess road(Access railway)Pier for reception of aggregate, cement, reinforcement, etc.Channel for barges, tugs, and concrete structurePrepared site for storage, offices, workshops, etc.Prepared dock or bargesElectricity, including standby aggregatesClean waterSewage treatment <p><u>Equipment</u></p> <ul style="list-style-type: none">Form workSlip-form equipmentCement storageConcrete mixing plantScaffoldingPumps to submerge platform

⁴⁵ Gudmestad O.T., Aas Warland T, Stead B.L. 1993. Concrete structures for Development of Offshore fields. Statoil A/S

Fabrication of the topsides can be executed in Europe or East Asia and be delivered to the place of installation. Topside facilities can be installed at the dry dock or at the offshore site. In the second case, this may either be performed as a high deck float over or by lifting of modules.

An example of OIRFPs construction and installation for the Sakhalin projects is shown in Figure 29.



Figure 29 - Construction and installation of OIRFPs for Sakhalin projects⁴⁶

However, for Arctic conditions hook up and completing of topsides offshore might be too costly. The structure can be made of reinforced concrete or stainless steel. The concrete is a proven material for offshore structures as it has good compressive strength characteristics. But, it also has bad tensile properties and, therefore, typically it is reinforced by steel.

Other issues relate to the transportation of the GBS to the field, the lowering at its locations and the installation of decks on the GBS with a float-over installation method.

The transportation method could be similar to that was applied to the Prirazlomnaya platform. Several vessels tow the structure from the construction yard to the installation place.

After the unit has reached the installation place, it is lowered to the sea bottom. The unit can be kept in place due to its own weight, supported with special built rock berm. The rock berm can be packed using the method shown in Figure 30.

⁴⁶ Eie R., Rognaas G., Kvaerner Concrete Solutions AS. 2014. Fixed Platforms - Development Challenges in Ice Infested Arctic. OTC 24578 (Offshore Technology Conference)

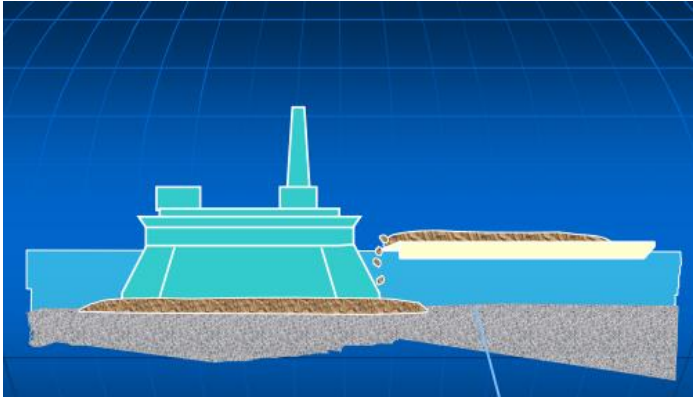

Figure 30 – Rock berm packing method³⁶

13.8. EXPLOITATION PROBLEMS

Problem 1 – Offloading operation

In Arctic region, when the oil is offloaded from the offshore platform to tankers, the tankers should have an access to the platform. In winter this access can be a problem due to the ice drift. Caisson-type GBSs have large dimensions (100 m and more), thus, the area of such structure at MWL is also large. Since the drift of ice sheets is affected by the direction of the current, a wide ice free zone (wake) is formed behind the platform along the direction of the current [Fig. 31]. The tankers use this pass to avoid large ice loads while offloading oil.

However, when the wind force increases, it changes the ice drift direction making it dramatically deviated from the direction of the current. Moreover, the wind can easily change its course during the day that means possible changes in direction of the wake for up to 360 degrees. It creates some difficulties for the tankers as offloading centers are usually installed at one or two sides of the platform. For example, the Prirazlomnaya platform has only two offloading centers at opposite corners of the platform, along the direction of the current, such that there is a certain weather window for conducting the operation, i.e. it can be done only when the wake is at the side of offloading centers as shown in Figure 31 (right).

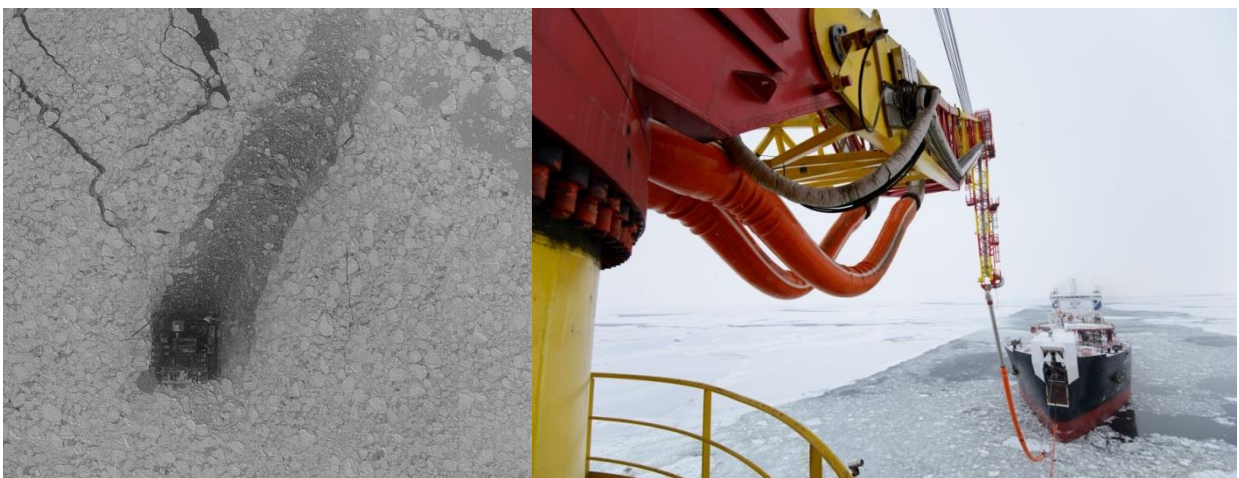

Figure 31 – Satellite picture of wake at the Prirazlomnaya platform (left) and offloading operation (right)³⁶

The tanker is obligated to follow the ice drift direction because of the specifics of a dynamic positioning system. The system determines the position of the tanker in relation to the offloading center on the platform. At the Prirazlomnaya platform such center is called CUPON (crane with hose, through which oil is offloaded to the tanker from the storage tanks) that has a limited angle of rotation. In order to keep the hull of the tanker along the direction of the combined loads (ice drift, currents, wind, etc.), the wire that connects the tanker to the platform's offloading center should always be in tension. It also allows to not making a contact of the hose and the wire with ice sheets⁴⁷.

Since the hull of the Prirazlomnaya platform has a square shape and the offloading center is in the corner, the tanker can be exposed to large ice loads from one side, while offloading the oil. It can happen when the drift direction is in parallel to the wall of the platform's hull as it shown in Figure 32.

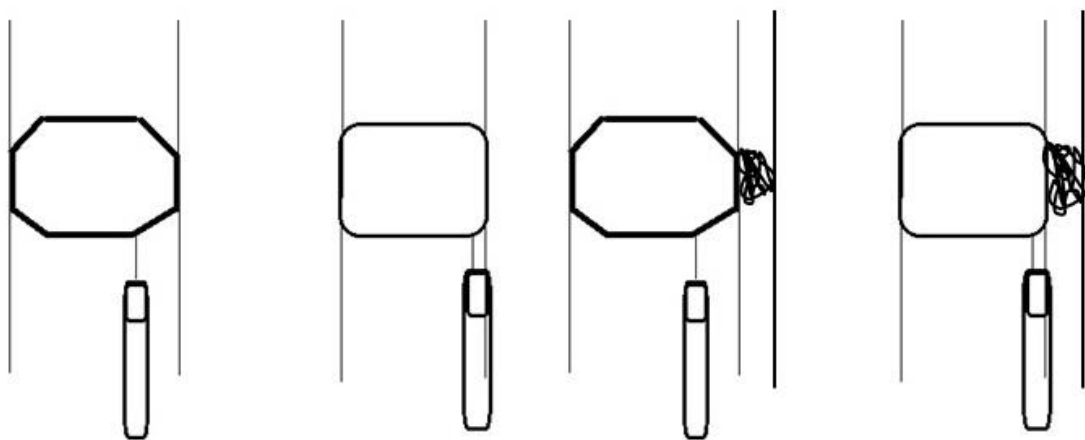

Figure 32 – Effect from different geometries of the platform's hull

Often, during the harsh ice period the ice rubble is formed in front of the platform. This rubble grows and can stand there for a long time. This problem is specified in Problem 2 below. During the offloading operation, such ice rubble makes the wake wider temporarily solving this problem as it shown in Figure 32 (right).

Changing the shape of the platform's hull, for example from square to octagonal or conical, can be a permanent solution. It would make it possible to place the offloading centers closer to the middle of the platform that in turn would broaden the wake providing more ice free space to the tanker.

An alternative solution is to build a special terminal like the Varandey Oil Terminal at some distance from the field. The gib arm of such terminal can rotate around its axis almost for 360 degrees that solves the problem with offloading oil. The schematics of the Terminal is shown in Appendix 4. However, it would lead to significant capital expenditures, therefore, this way could be realised only if this terminal has been using by several offshore fields under development.

⁴⁷ Based on interview with the Department of marine operations, LLC "Gazprom neft shelf"

This solution would also allow to get more free space for topsides of the platforms having storage tanks.

Using a multi-column platform there are also possible problems with the offloading operation. Because of the space between columns the wake can be unstable and occur temporary. However, since the columns would break the ice sheet into pieces, the ice load would be less in the wake area.

Use of ice deflectors in the column design would reduce the ice loads on the columns, vibration caused by ice sheet failure, and would increase the diameter of the column so that the appropriate wake can be formed behind the column.

However the use of ice deflectors at every column might cause ice rubbing between the columns that is a risk to tankers.

Problem 2 – Ice rubbing

The ice is often accumulated at a side of the platform hull consolidating and forming ice rubble [Fig. 33] that can impede the vessels to get close to the platform. The rubble is hard to remove as it can be formed again and again during the winter at different sides of the platform (even at several sides simultaneously). So, it's necessary to implement a special system that will prevent the ice accumulation at any side of the hull.



Figure 33 – Ice rubbles in front of the platform³⁶

The vessels can't get close to the platform. Taking into account that the length of the cargo crane (for example) is around 50 m and the width of the ice rubble could be the same, lifting cargo from the vessels could become a challenge.

The ice rubble increases the load on the structure until it's grounded. When it's grounded, a part of ice load is transferred to the sea-bottom reducing the load on the structure. According to different estimations the grounding of ice rubble can be in up to 20 m water depth. At the Prirazlomnaya platform such rubble can damage the rock berm around the platform that would reduce horizontal stability of the platform (against combined horizontal loads of currents, waves and ice drift).

At the Dolginskoye field this situation is unlikely, because the water depth in the area is around 40 m. However, the problems with lifting cargo from vessels and increased ice loads remain.

Changing the shape of the platform's hull might be a solution for this problem as well. Octagonal or conical shape would reduce the ice-platform's wall contact area and consequently ice rubble volume at each side as it is schematically drawn in Figure 34. Thus, the possibility of flushing the rubbles by currents and ice drift increases.

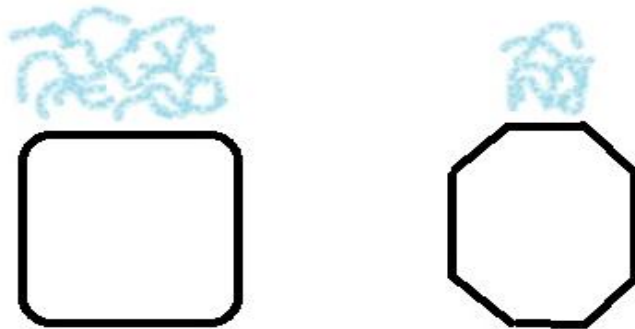

Figure 34 – Ice accumulation scenario for different hull shapes

In order to prevent the formation of ice rubbles, several solutions might be proposed such as flushing the ice by the vessel's thrusters, application of mechanical devices to break the ice or deviate the moving ice, heating the zone around the platform or by air flushing (bubbles are ejected from the perforated pipes at the sea bottom and drive warmer water to the surface that can prevent ice accretion). But the effect from all these methods has not been studied sufficiently.

Problem 3 – Ice-structure-seabottom interaction

As the proposed unit can be applied only in shallow water the ice-management is minimized. If an ice ridge is drifting toward the structure, its keel will stack in sea bottom. If the ice is too thick, an icebreaker can be used to break the drifting ice around the unit. Another method is to install so called ice cutters and sloping ice barriers at some distance from the unit. They will stop a part of drifting ice that will reduce the load on the structure. The technology has already been realized at some fields in the Caspian Sea. However, for the depth of 20 m, where it is of interest at the Dolginskoye field, the construction of such barriers might be too costly.

The ice-management is very important, because drifting ice can negatively influence on the structure. The structures with sloping walls can have upward or downward cone angle as shown in Figure 35. Acting on the upward cone angle (left picture) the ice increases the vertical load on the sea bottom that can lead to subsidence or offset of the structure by one side. Acting on the downward cone angle (right picture) the ice reduces the vertical load on the sea bottom, but the structure can be overturned.

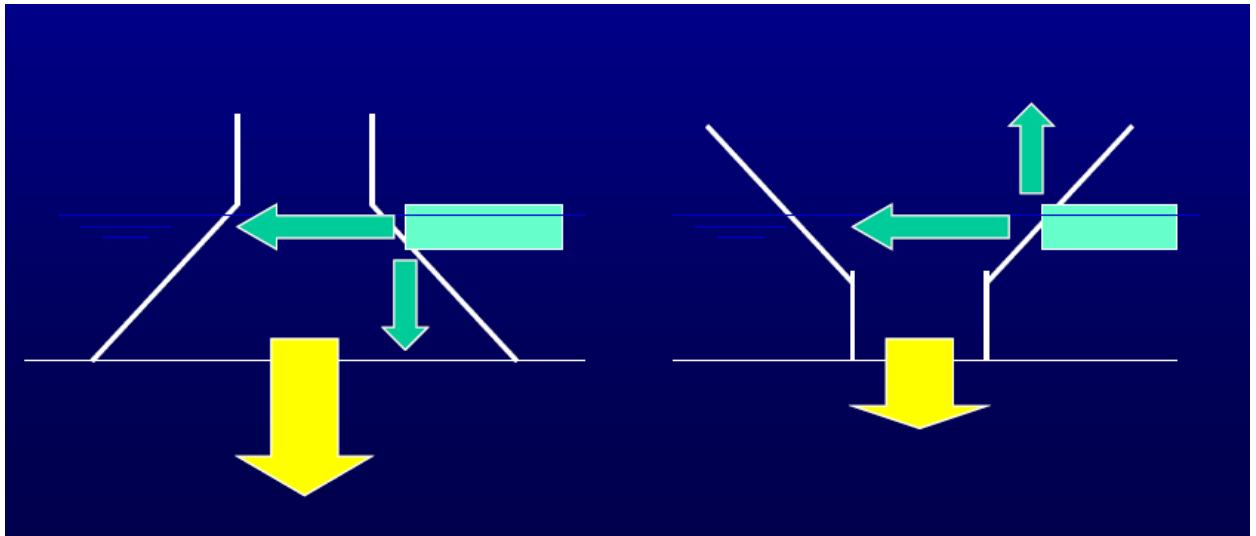

Figure 35 – Effect of ice on structures with upward/downward cone angle³⁰

So it's very important to accurately estimate soil-bearing capacity (hardness) and the maximum weight of the structure. In this term, the evaluation of GBS's foundation size is important. Higher loads imply higher foundation size to provide sea-bottom stability for the structure.

14. ECONOMIC ANALYSIS



Economic analysis of the project was carried out using the program Questor 10.1, 2010.

Initial data

For this analysis, initial data is based on VNIIGAZ research²⁰ [Fig. 36].

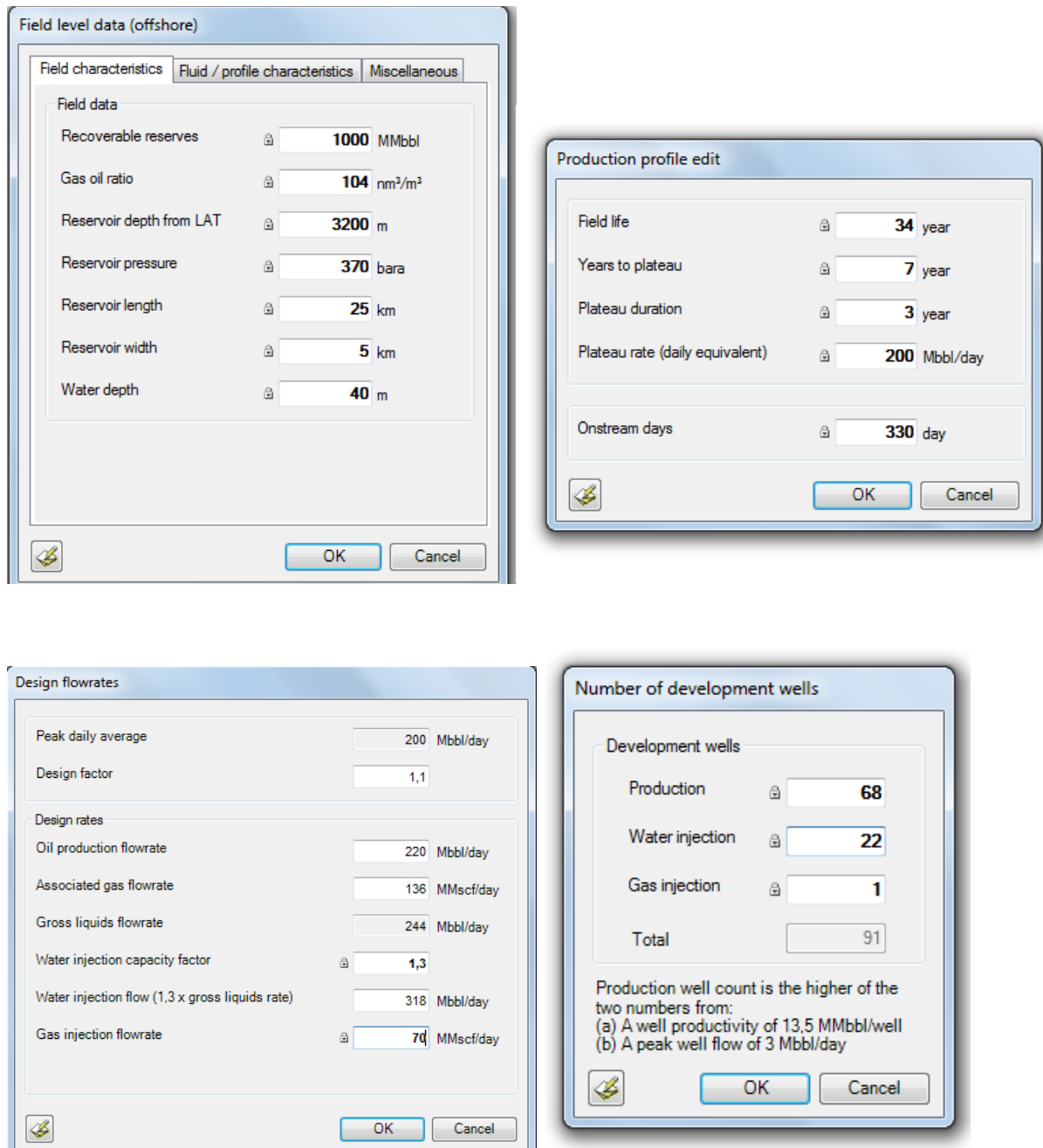

Figure 36 – Initial data for cost estimate (Questor 10.1)

The length, width and depth of the reservoir are average values for all horizons of the North-Dolginskaya structure.

Onstream days are estimated as 365 days multiplied to Downtime rate which is 0,9.

Gas injection flowrate is half an **associated gas flowrate**, another part supposed to be used for platform needs.

The following field development scenarios have been analyzed:

- 1 host platform + 2 wellhead platforms
- 1 host platform + 2 subsea modules
- 1 host platform + 1 wellhead platform

1 host platform + 2 wellhead platforms

As a result, we obtained the value of capital expenditures (CAPEX) of 4 billion U.S. dollars and operating expenditures (OPEX) of 6 billion U.S. dollars. Total costs are estimated at about 10 billion U.S. dollars.

1 host platform + 2 subsea modules

As a result, we obtained the value of capital expenditures (CAPEX) of 3,4 billion U.S. dollars and operating expenditures (OPEX) of 7 billion U.S. dollars. Total costs are estimated at about 10.4 billion U.S. dollars.

1 host platform + 1 wellhead platforms

As a result, we obtained the value of capital expenditures (CAPEX) of 3,3 billion U.S. dollars and operating expenditures (OPEX) of 5.5 billion U.S. dollars. Total costs are estimated at about 8,8 billion U.S. dollars. In this scenario, an additional cost required to drill long horizontal wells (up to 7 km from each platform).

These costs are considered as underestimated, since the calculation was made based on the databases from 2010, and not all indicators were taken into account. Moreover, the accuracy of the cost estimate at conceptual stage of the project is $\pm 40\%$. The accuracy at different stages of the project is shown in Table 12 and Figure 37.

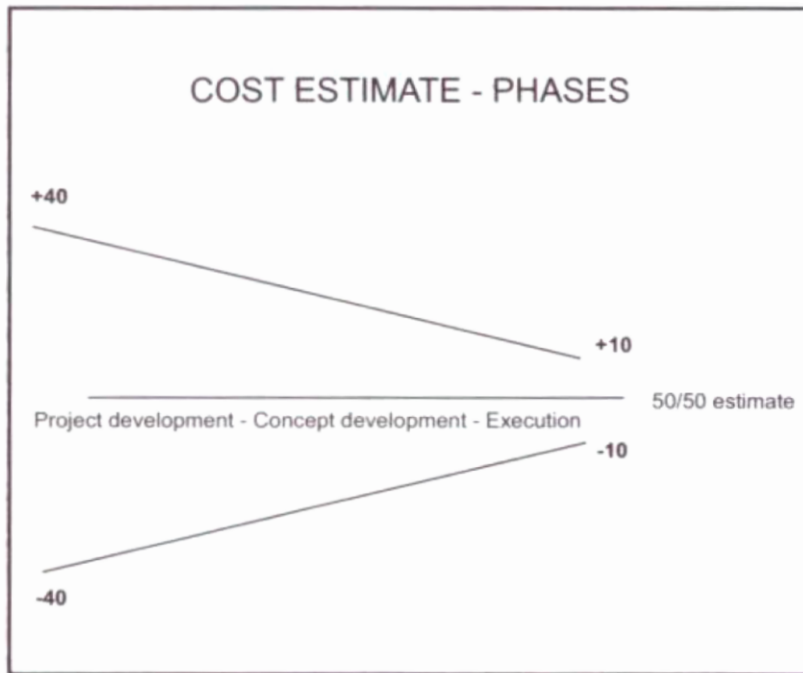

Figure 37 - Cost estimate in different phases of the project development⁸

Table 12 – Accuracy of cost estimate⁸

Estimation class	Purpose	Accuracy(typical)
Order of magnitude	Prospect evaluations	—
Conceptual	Assess economical potentials (Decision to prepare firm development plans)	+/- 40%
Preliminary	Evaluate/rank the alternatives (Decision to continue the work and Plan for Development and Operation)	+/- 30%
Definitive	Plan for Development and Operation	+/- 20%
Control	Basis for Project control	+/- 10%

For the first scenario:

- A more detailed description of the costs is represented in Appendix 6.
- Also possible production profiles of oil and gas at the Dolginskoye field have been obtained using the same program, taking into account an estimated Dolginskoye field lifetime of 34 years²⁰. Graphs showing the annual profiles are shown in Figure 38.

- A possible schedule of different stages of the project is shown in Figure 39. According to the schedule, construction of the platforms, the offshore loading and pipeline installation could be completed by the middle of 2018. However, some operations must possibly be extended to 2020.

Conclusion:

Calculations have shown that subsea modules require less CAPEX but higher OPEX than scenario with only fixed platforms. But the overall cost is less than the first scenario (1 host platform + 2 wellhead platforms).

As a result of economic analysis, installation of two platforms (one multi-column, one monocone) requires less CAPEX and OPEX than scenario with 3 platforms and scenario with 1 host platform + 2 subsea modules.

It is obvious that the scenario with 1 host platform + 1 subsea module would require less CAPEX than all considered scenarios. However, it can require higher OPEX and the total cost of the project can be similar or even higher than for some other scenarios.

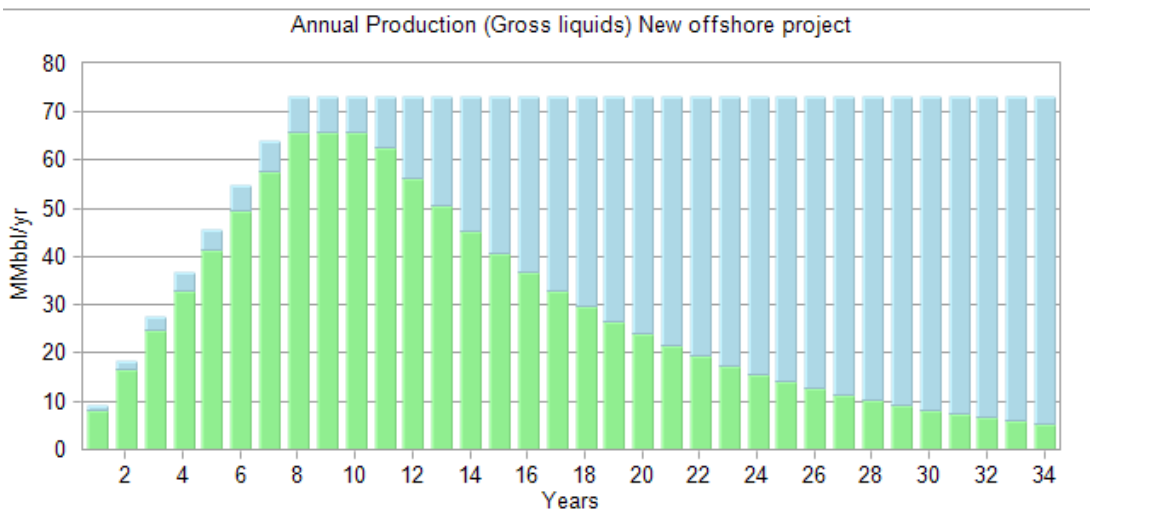
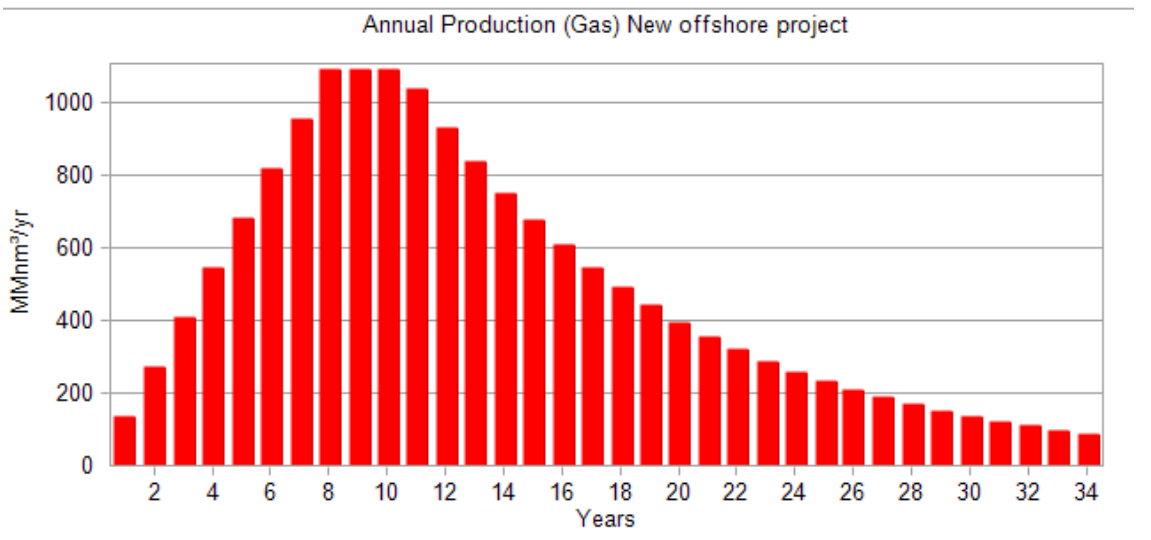
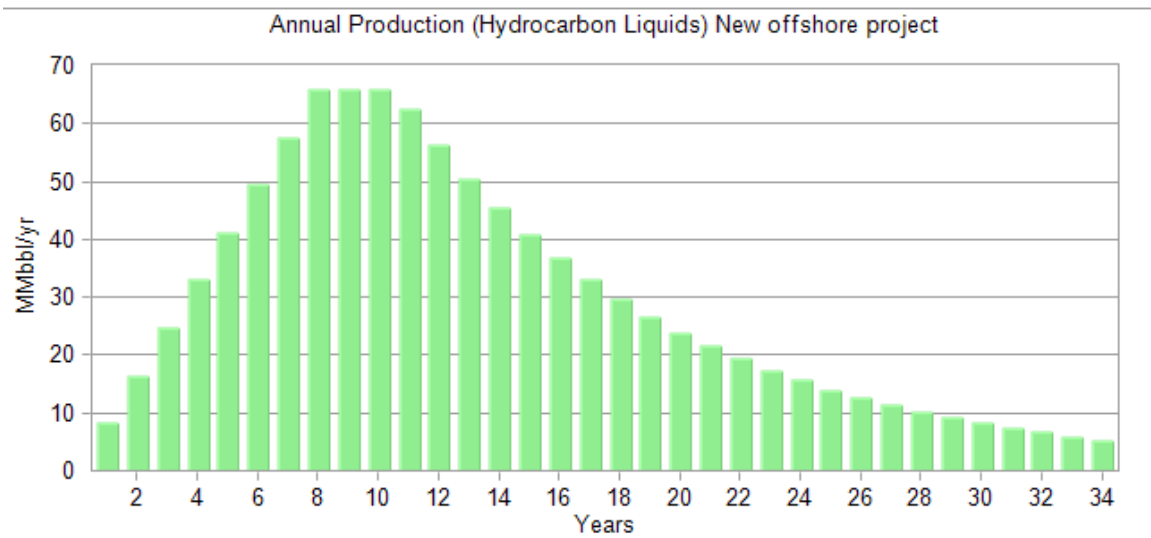

Figure 38 – Possible annual production profiles (Questor 10.1)

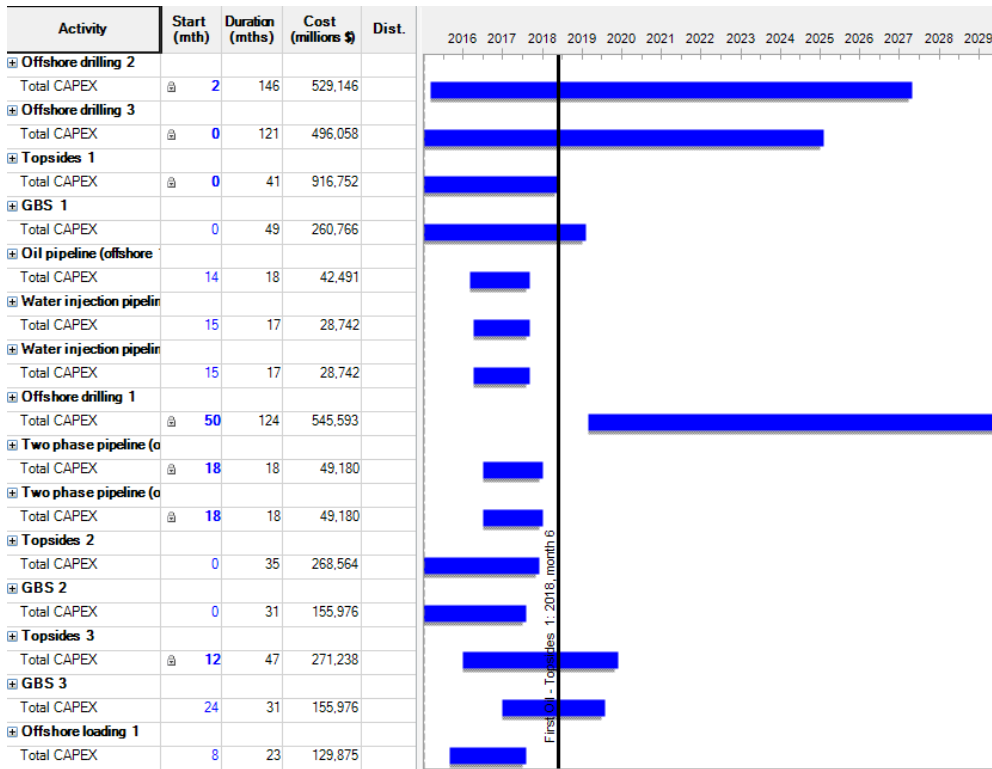
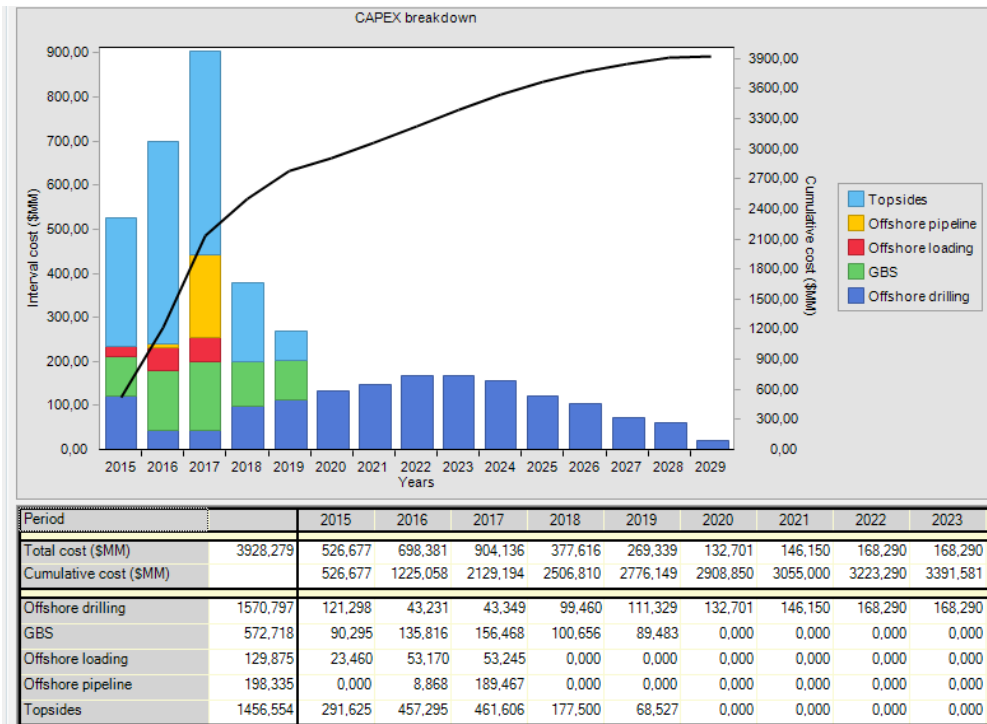
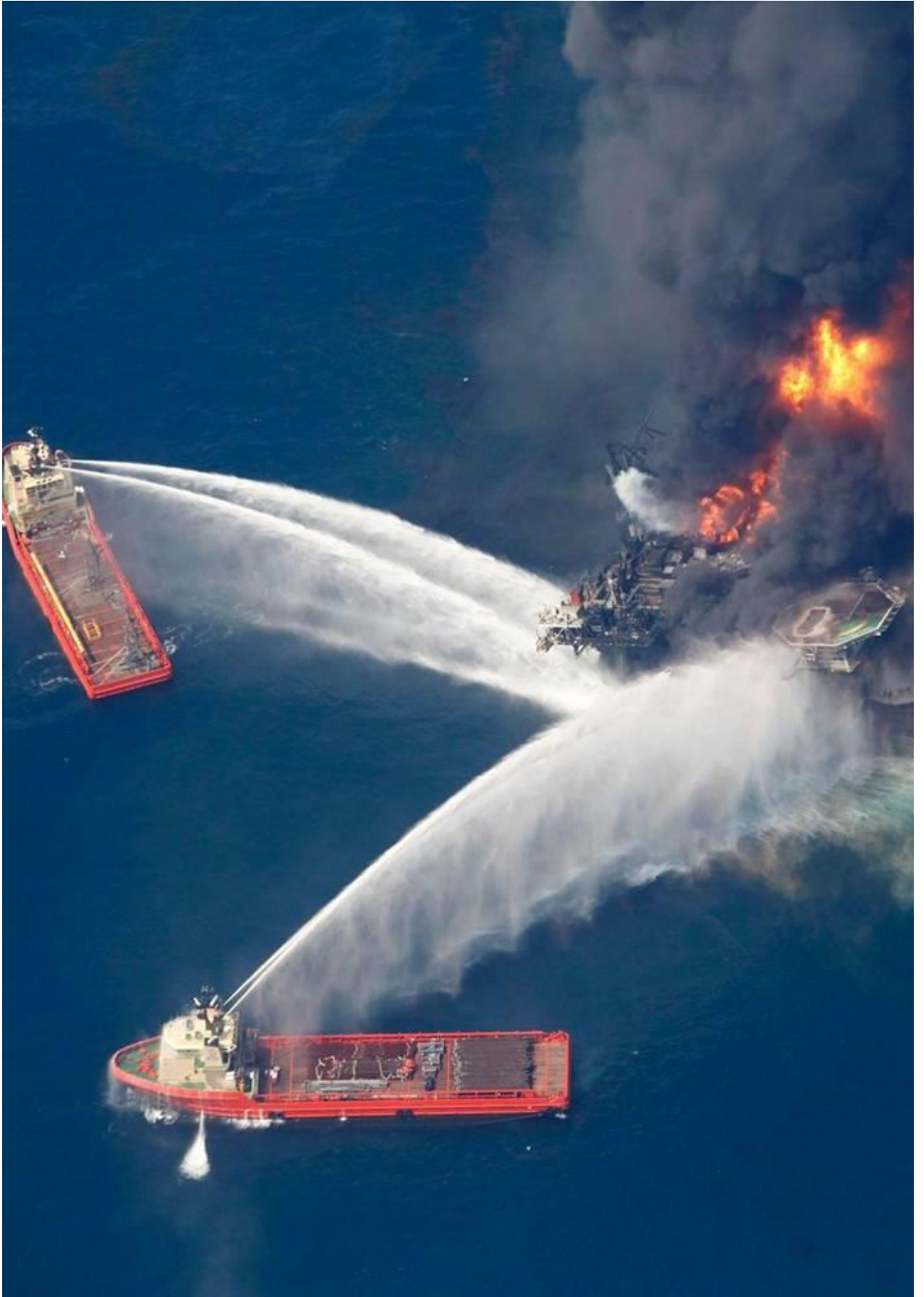

Figure 39 – Possible project schedule (Questor 10.1)

15. RISK ANALYSIS



Every offshore project faces to high risks during its realization. Relating to the area of the Dolginskoye field we can assume the following factors leading to dangerous events:

- ✓ Severe climate conditions create many challenges for the field development in the area. As a weather window can often be short, it makes it more complex to transport the facility to the site and install it on the ground base.
- ✓ Presence of ice and large waves means high loads onto the structure walls and equipment.
- ✓ There is a lack of technology for oil and gas recovery in the Arctic and the existing experience is still not enough to make the innovative technology field-proven that can exclude it from consideration for the project.
- ✓ Deficit of qualified personnel commits operators to employ other consultants and workers from experienced international companies.
- ✓ All these factors dramatically increase the project cost that in turn creates a significant financial risk.
- ✓ Remote offshore location leads to transportation of hydrocarbon products over long distances increasing the chances of having storm conditions that expose the tankers or pipelines to high risks to be damaged.

Additionally, the environmental risks are not yet fully understood, but there is no doubt the Arctic is very fragile area and any incident or failure can cause serious problems not only for environment but for the people around the World. At the moment, there is no such efficient technology for accident elimination in the Arctic waters, especially in winter time when the oil spill can occur under the ice. Emergency response time is also a big problem as existing EER facilities in the area are not enough even for eliminating of small oil spill. Thus, waiting for additional help will strongly extend Emergency response time and the situation can run out of control.

In general, an offshore project can have the following risk categories:

- Risk to personnel
- Risk to environment
- Risk to reputation
- Financial risk

HAZOP procedure is presented in Table 13.

Table 13 – HAZOP analysis⁴⁸

Hazard & Operability Analysis (HAZOP)

No.	Guide Word	Element	Deviation	Possible Causes	Consequences	Safeguards	Comments	Actions Required	Actions Assigned to
Assign each entry a unique tracking number	Insert deviation guide word used	Describe what the guide word pertains to (material, process step, etc.)	Describe the deviation	Describe how the deviation may occur	Describe what may happen if the deviation occurs	List controls (preventive or reactive) that reduce deviation likelihood or severity	Capture key relevant rationale, assumptions, data, etc.	Identify any hazard mitigation or control actions required	Record who is responsible for actions
Examples from Cleaning Agent Deviations that were used to explain HAZOP Guide Words									
1	No	Cleaning Agent	No detergent added during cleaning cycle	Detergent supply reservoir empty	Residues not effectively removed, leaving system in an unclean state	Technicians check detergent reservoir before every cycle	Assumes technicians can reliably estimate volume visually	Consider alarm for low detergent reservoir level	Engineer
2	Other than	Cleaning Agent	Wrong detergent used	Technician retrieves wrong detergent from warehouse	Incorrect detergent may be ineffective at removing residues, leaving system in an unclean state	Cleaning log requires verification of proper detergent use. Detergent is labeled.	Many different detergent containers look alike	Ensure technician training addresses detergent selection	Trainer

There is a special classification of probabilities and consequences made by Gazprom. This classification is used to estimate different risks for every operation at company’s fields. It is presented in Tables 14 and 15.

Table 14 – Classification of probabilities of hazardous events⁴⁹

Level of probability of hazardous events	Point scoring	Interpretation	Alternative interpretation based on historical data (for current risks)	Percentage probability interpretation
Very high	5	An event will happen almost exactly	Several cases in the company during a year	>80%
High	4	An event is likely	Several cases in the group of companies «Gazprom neft» (GPN) during a year	50-80%
Middle	3	An event may happen	There was a case in one company in the group	20-50%
Low	2	An event is unlikely	Similar cases have occurred in the history of GPN	5-20%
Very low	1	It is extremely unlikely that an event can happen	Similar cases have not recorded in GPN, but recorded in the industry	<5%

⁴⁸ American Society of Safety Engineers. 2014. Manufacturing Technology Committee – Risk Management Working Group. Risk Management Training Guides. <http://www.oshrisk.org/>

⁴⁹ “Gazprom neft” Ltd. 2013. Guidance for Risk analysis. Группа компаний ГПН. 2013. Методические указания по процессу управления рисками

Table 15 – Classification of consequences of hazardous events⁴⁹

Level of consequences	Point scoring	Risk to people (L)	Risk to environment (E)	Risk to reputation (R)	Financial risk (F)
Very high	5	Irreparable harm to health (total incapacity for work) and /or life (deaths) more than one staff member (group fatal accident)	Long term significant negative impact on the environment or harmful influence over large areas. Damage to enterprises, recreational areas or nature reserves.	International attention. Widespread negative reputation in the international media. Impact on regional / national policies with potential effects on access to new areas, licensing and/or tax legislation.	>16 billion rubles
High	4	Irreparable harm to health (total incapacity to work) and / or life (deaths) of one staff member.	Significant environmental damage. Group GPN should carry out large-scale recovery works to restore the area. Long-term violation of limit values or widespread harmful influence.	Public concern at the national level. Widespread negative reputation in the national media. Impact on regional / national policies with the potential for restrictive measures and / or impact on the issuance of licenses.	8-16 billion rubles
Middle	3	Partial incapacity for work of one staff member. Duration (2 weeks) temporary incapacity of staff member / membres to work	Limited emissions affecting neighborhoods and environmentally damaging. Repeated violations of emission limits.	Regional public concern. Widespread negative attention from the local media. Some national media coverage and / or attention from local / regional authorities. Negative position of local government / community groups.	3-8 billion rubles
Low	2	Temporary incapacity of staff members (not more than 5 persons) to work (no more than 2 weeks).	Noticeable contamination or environmental pollution, but without long-term effects (less than a year)	Some concern in the local community. Some attention from local media or local political authorities, which could adversely affect the Group's companies GPN.	300 million - 3 billion rubles
Very low	1	Worker was injured without incapacitation to work	Slight damage to the environment on the territory of the enterprise and \ or enterprise systems incapacitation	Public may know something, but no concern	<300 million rubles.

First of all we should determine all possible hazards and find out the reasons of their occurrence and consequences.

For evaluation of the level of the risks the risk matrix is used [Fig. 40].

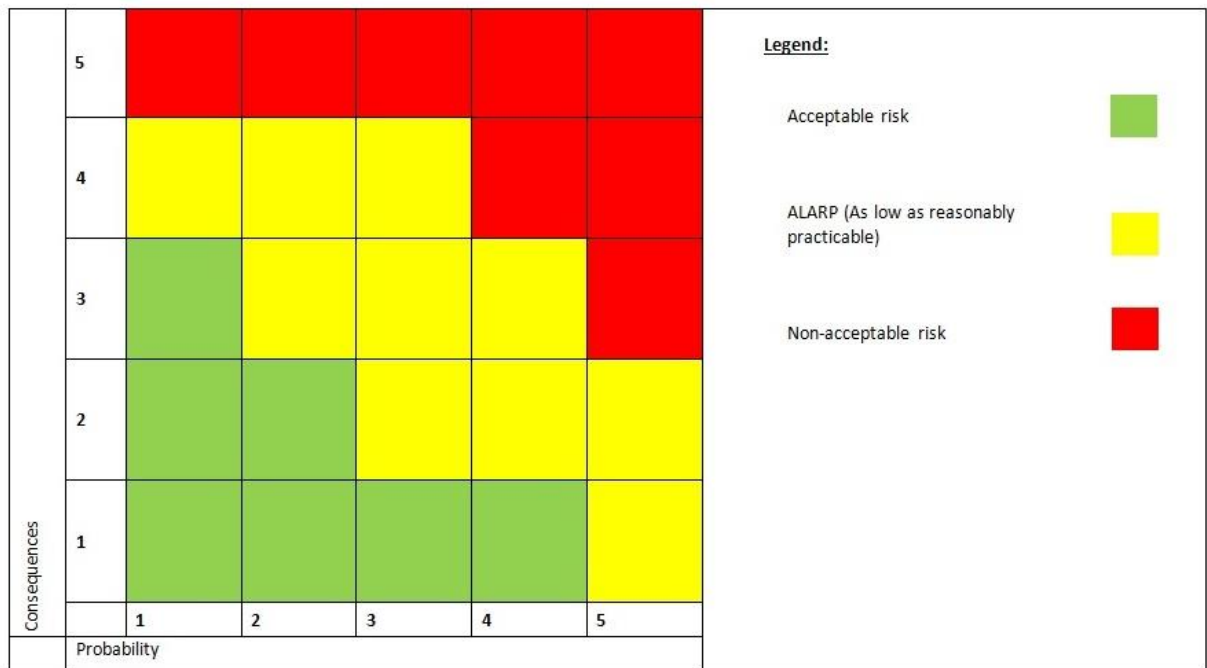

Figure 40 – Risk matrix

Bow-Tie diagram⁵⁰

As an example of Bow-tie diagram the oil spill was chosen since it's supposed to be the most hazardous risk to environment and finances. The possible distribution of the oil spill is shown in Figure 41.

⁵⁰Risk management. Use of methods and procedures for risk analysis in the sphere of technical regulations. Rosstandart 2010. Менеджмент рисков. Использование методологии и процедур оценки рисков в сфере технического регулирования. Росстандарт 2010. Available from: http://expert.gost.ru/NAV.php?ID=RA/HTML/RA_ML_06.html. (read 9.04.2014)

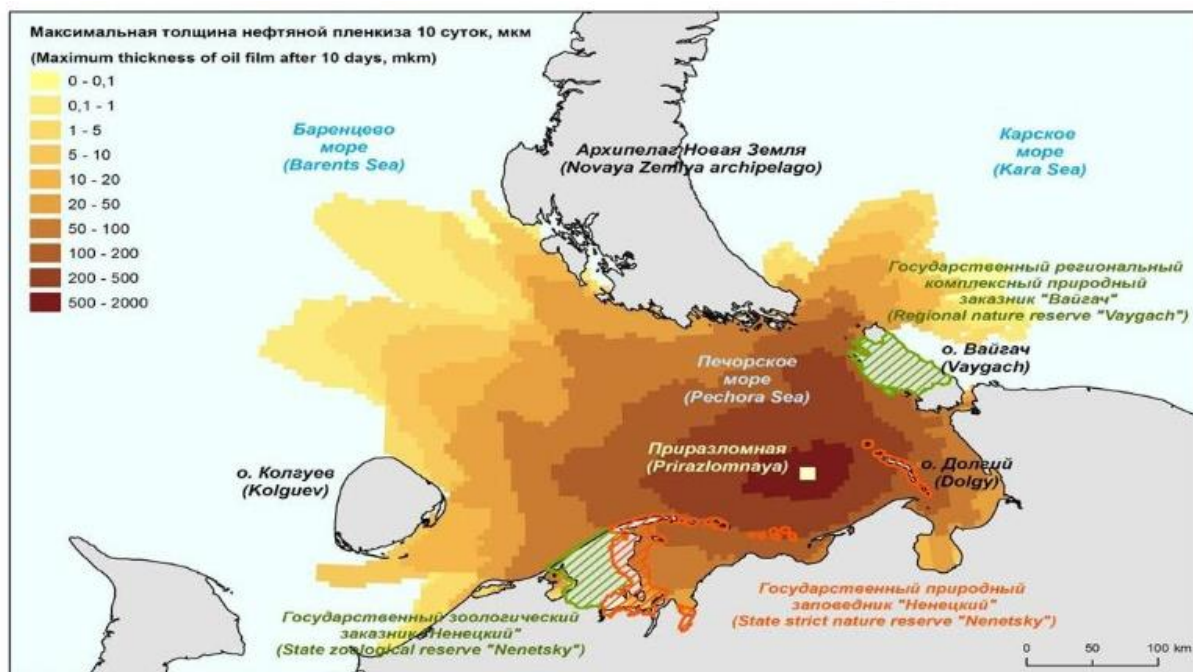

Figure 41 – Potential oil pollution of the seawaters and the shoreline after oil spill of 10000 t over 5 days⁵¹

In case of an oil spill at Dolginskoye field, the number of vessels which are able to react to this disaster will be counted from those applied for the field as it planned in the project, and those currently existing in the area as shown in Figure 42.



Figure 42 – Vessels currently exploiting in the Pechora Sea³⁶

⁵¹ Oil spill from the Prirazlomnaya platform is a disaster for the region. 2012. Available from: <http://www.greenpeace.org/russia/ru/news/2012/August/14-080-2012-razliv-nefti-na-Prirazlomnoy-stanet-katastrofoy/>. Разлив нефти на платформе «Приразломная» грозит региону непоправимой катастрофой. 2012

The Bow-tie diagram describing the oil spill is presented in Figure 43.

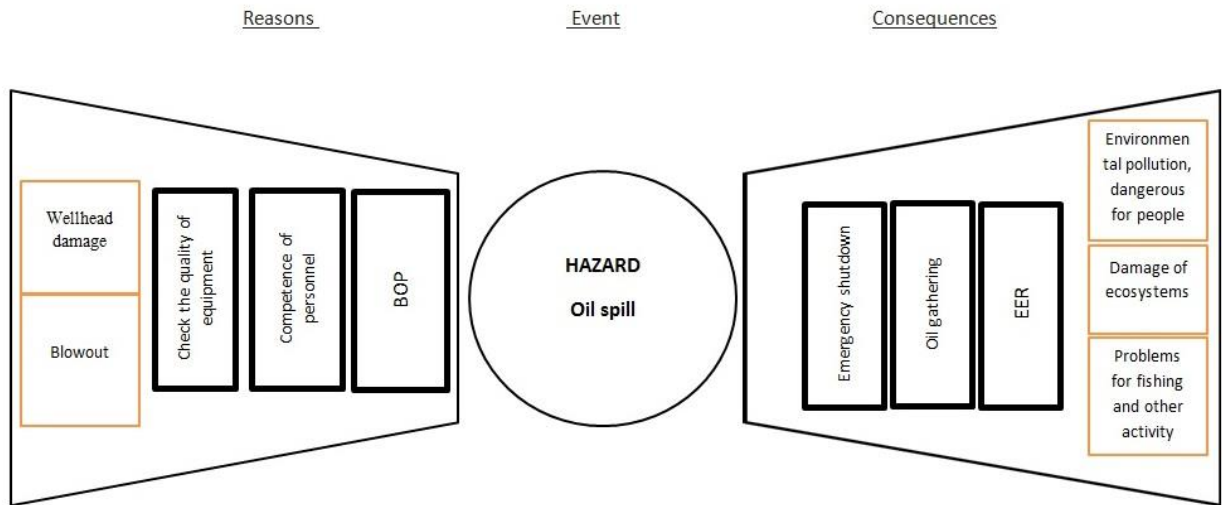

Figure 43 – Bow-tie diagram

16. CONCLUSIONS AND REMARKS

Considering the different concepts and analyzing their advantages and disadvantages we can estimate the efficiency of each of them.

A Gravity Based Structure is a suitable solution for shallow water and all the concepts described in this report are applicable for the extreme Arctic environment including first and multi-year ice, ice ridges and icebergs in the winter and waves and currents in the summer. Each concept is designed for the round-year operation on conditions that it is supported by ice-management procedures.

The proposed platform designs and their configuration can be modified during the project execution and applied in the future for other regions of the Arctic shelf having similar environmental parameters. However, each design requires more accurate estimation and time in order to be implemented in a real project.

The calculation results show the values of the total force acting on the structures. These results also allow us to develop the concept designs, making necessary changes and optimizations.

Analyzing the calculations in Appendix 1 we can see that the less steep slope of the structural walls provides the less horizontal ice load. For a structure with a steep slope the deck size will be close to the foundation size, but the steepness is limited, because there is a critical angle where the ice failure mode changes from bending to crushing. However, if the slope is too slight, the structure's foundation size will be too big and its fabrication could be inefficient. For most of slope angles the ride-up force is larger than ice-breaking force. The horizontal ice load due to adfreezing is smaller for the structures with steeper walls.

The calculation results in Appendix 2 show that different approaches for the estimation of ice ridge loads on offshore structures can give us very different values. The considered global load model gives lower ridge force values than the considered local load models. All methods used to determine failure forces of ridge keels, while the real failure mechanism could be more complex. Calculation results show that the consolidated layer creates the largest loads on a structure, but the results obtained by using the Korzhavin equation could be unrealistic due to many assumptions. Moreover, a lot of assumptions are used to determine the physical properties of the ice ridge and the ridge behavior during the interaction with structures.

17. REFERENCES

1. Zolotukhin A.B. 2012. Fundamentals of Petroleum Geology, Reservoir and Production Engineering. Lecture for the course "Offshore Field Development Technology". Gubkin Russian State University of Oil and Gas, Moscow
2. Ghoneim G.A., Veritas D.N. 2011. Arctic Standards – A Comparison and Gap Study. Arctic Technology Conference, Houston, Texas, USA. OTC 22039
3. Ermakov A.I. 2012. Course "Challenges of Offshore project development". Lecture #2 "Offshore Facilities and Techniques". Gubkin Russian State University of oil and gas
4. The seas of the World. The Pechora Sea (Russia). Available from: <http://inpath.ru/nature/sea/263>. (read 20.02.2014). Моря мира. Печорское море (Россия)
5. The course of lectures organized by Total Professors Associates. 2013. Arctic design. Offshore structures and ships. Northern (Arctic) Federal University named after M.V. Lomonosov
6. Novikov A.Y. 2014. Studies of stability of the drilling unit "Arcticheskaya" on the soil of Dolginskoye license sector. Explanatory note 130401.65.Д14.544.ВКР.ПЗ. Новиков А. Ю. 2014. Исследование устойчивости установки на грунте самоподъёмной буровой установки "Арктическая" на Долгинском лицензионном участке. Пояснительная записка 130401.65.Д14.544.ВКР.ПЗ
7. Arctic Europe Petroleum Resources and Infrastructure. Available from: <http://www.arctic-europe.com/>. (read 15.02.2014)
8. Gudmestad O.T., Zolotukhin A.B., Ermakov A.I., Jakobsen R.A., Michtchenko I.T., Vovk V.S., Loeset S., Shkhinek K.N. 1999. Basics of Offshore Petroleum Engineering and Development of Marine Facilities with Emphasis on the Arctic Offshore. Stavanger/Moscow/St. Petersburg/Trondheim. Publishing house "Oil and Gas", 1999
9. Barents Portal. Available from: <http://geodata.npolar.no>. (read 22.02.2014)
10. Lovo V., Elvernoi A., Antonsen P., Solheim A., Butenko G., Gregersen O. & Li Estoi O. 1990. Submarine permafrost and gas hydrates in the northern Barents Sea. Nr. 56 - Oslo
11. Edited by Paepe R., Melnikov V. P. 1998. Permafrost Response on Economic Development, Environmental Security and Natural resources. Novosibirsk, Russia
12. Offshore geohazards. 2010. International Centre for Geohazards. Available from: <http://www.ngi.no/en/Geohazards/Research/Offshore-Geohazards/>. (read 13.03.2014)
13. Srinivasan N., Singh S. 2008. Design of a Non-Ship-Shaped FPSO for Sakhalin-V Deepwater. SPE 114882
14. Total Professors Associates. 2013. The course of lectures "Arctic design. Offshore structures and ships". Gubkin Russian State University of oil and gas
15. Study group AT-307. 2014. UNIS's course AT-307 «Arctic Offshore Engineering – Fieldwork». Group report. Longyearbyen
16. Løset S. 2013. Ice Mechanics. Rheology. Lecture 4, the course AT-327, UNIS
17. Cox G.F.N. and Weeks W.F. 1983. Equations for determining the gas and brine volumes in sea-ice samples. Journal of Glaciology. Vol. 29. No. 102.
18. Gazprom нефть shelf. 2011. Report «Development of the Prirazlomnoye and Dolginskoye fields». Moscow. ООО «Газпром нефть шельф». 2011. Доклад «Обустройство Приразломного и Долгинского месторождений». Москва
19. Forecast of presence of oil and gas in the Dolginskaya geological structure based on simulation results using optically active materials. Vovk V.S, Dzyublo A.D, Demetry T.V, Ryabukhina S.G, Zaitsev A.V. Oil and Gas Geology, 3-2008. Available from: http://www.geoinform.ru/?an=vovk_ru. (read 16.05.2014). Прогноз нефтегазоносности Долгинской площади по результатам моделирования на оптически-активных материалах. Вовк В.С., Дзюбло А.Д., Дмитриевская Т.В., Рябухина С.Г., Зайцев А.В., Геология нефти и газа, 3-2008

20. VNIIGAS. 2008. Report "Synergy of the Prirazlomnaya project with other projects". ВНИИГАЗ. 2008. Реферат «Обеспечение синергии проекта обустройства Приразломного нефтяного месторождения с другими проектами»
21. Løset S. 2013. The ice cover and drift of sea ice. Lecture 3, the course AT-327, UNIS
22. McKenna R., Spring W., Thomas G. 2011. Use of the ISO 19906 Arctic Structures Standard. The Arctic Technology Conference, Houston, Texas, USA. OTC 22074
23. Løset S. 2013. Ice Actions and Action Effects. ISO 19906 Arctic Offshore Structures. Lecture 7, the course AT-327, UNIS
24. Fuglem M., Stuckey P., Jordaan I. 2011. Probabilistic Ice Loads Assessments for Arctic Regions: Inputs for Calibration of ISO 19906. The Arctic Technology Conference, Houston, Texas, USA. OTC 22070
25. Bercha F.G. 1994. Evolution of Arctic Marine Structural Forms. The 26th Annual Offshore Technology Conference, Houston, Texas, U.S.A. OTC 7461
26. Bulakh Maria, Zolotukhin A.B., Gudmestad O.T. 2011. The Kara Sea Offshore as a Strategic HC Recourse Base in the 21. Possible Solutions of Developing According to the Estimate of the Economy. Uncertainties by Fuzzy Theory. SPE 149655. SPE Arctic and Extreme Environments Conference & Exhibition, Moscow, Russia
27. Løset S. 2013. Global and Local Ice Loads. Lecture 6, the course AT-327, UNIS
28. University Courses on Svalbard. 2001. AT-204 Thermo-Mechanical Properties of Materials, 3 vt, 9 ECTS. Examination – suggested solution (problem sets 2 and 3)
29. Bellendir E.N., Vedeneev B.E., Toropov E.E. 2000. Analysis of Various Designs of the Stationary Platform Substructures for the Pechora Sea Shelf. The Tenth International Offshore and Polar Engineering Conference Seattle, USA
30. Løset S. 2013. Ice Loads on Sloping-Sided Structures. Lecture 8, the course AT-327, UNIS
31. Karulin E. B., Karulina M. M., Blagovidov L. B. 2007. Ice Model Tests of Caisson Platform in Shallow Water. International Journal of Offshore and Polar Engineering. ISSN 1053-5381
32. Timco G.W., Frederking R., Kamesaki K., Tada H. 1999. Comparison of ice load calculation algorithms for first-year ridges. Proceedings International Workshop on Rational Evaluation of Ice Forces on Structures, REIFS'99, pp. 88-102
33. Gazprom нефть shelf. 2011. Development of the Prirazlomnoye oil field. Report of CEO at the conference "Euro-Arctic 2011". ООО «Газпром нефть шельф». 2011. Обустройство и освоение приразломного нефтяного месторождения. Доклад генерального директора на конференции «Евро-Арктика-2011»
34. Info Step. 2012. Available from: www.info-step.com. (read 25.05.2014)
35. Gathering and Distribution system. Available from: www.subsea1.com. (read 11.04.2014)
36. «Gazprom нефть shelf» LLC. Official site. Available from: www.shelf-neft.gazprom.ru (read 19.02.2014)
37. Prirazlomnoye Oil field - Russia. Available from: <http://www.offshore-technology.com/projects/prirazlomnoye/>. (read 17.03.2014)
38. Lukoil's Varandey Terminal: one year of successful operation on the Russian Arctic Shelf. Press-release 2009. Available from: http://www.lukoil.com/press.asp?div_id=1&id=3077. (read 17.03.2014)
39. Engineering Services. Arctic Capability Statement. Available from: www.arup.com (read 19.03.2014)
40. Musabirov A.A. 2013. Development and studies of application of new Ice-resistant Platform design for shallow water Arctic shelf. Report. Moscow. Мусаби́ров А. А. Разработка и исследование применимости новой конструкции ледостойких платформ на мелководном Арктическом шельфе. Доклад, Москва 2013
41. Britannia, United Kingdom. Available from: <http://www.offshore-technology.com/projects/britannia/britannia3.html>. (read 25.05.2014)

42. Sandvik K., Eie R. and Advocaat J., of Aker Kvaerner Engineering & Technology AS. 2004. Offshore Structures – A new challenge. How can the experience from the marine concrete industry be utilized. XIV National Conference on Structural Engineering, Acapulco
43. Garnat O. 2006. Perspectives for a dry dock construction. Journal “North industrial” #5. Гарнат О. 2006. Перспективы строительства сухого дока. Журнал "СЕВЕР промышленный" № 5. Available from: <http://helion-ltd.ru/buildingdrydock/>. (read 1.06.2014)
44. Hoff G.C, Reusswig G., and Ugaz O.G., Mobil R&D Corp. 1993. Concrete GBS Platforms and Site Considerations for Southeast Asia: Structural Concepts. OTC 7160 (Offshore Technology Conference)
45. Gudmestad O.T., Aas Warland T, Stead B.L. 1993. Concrete structures for Development of Offshore fields. Statoil A/S
46. Eie R., Rognaaas G., Kvaerner Concrete Solutions AS. 2014. Fixed Platforms - Development Challenges in Ice Infested Arctic. OTC 24578 (Offshore Technology Conference)
47. Based on interview with the Department of marine operations, LLC “Gazprom neft shelf”
48. American Society of Safety Engineers. 2014. Manufacturing Technology Committee – Risk Management Working Group. Risk Management Training Guides. <http://www.oshrisk.org/>
49. “Gazprom neft” Ltd. 2013. Guidance for Risk analysis. Группа компаний ГПН. 2013. Методические указания по процессу управления рисками
50. Risk management. Use of methods and procedures for risk analysis in the sphere of technical regulations. Rosstandart 2010. Менеджмент рисков. Использование методологии и процедур оценки рисков в сфере технического регулирования. Росстандарт 2010. Available from: http://expert.gost.ru/NAV.php?ID=RA/HTML/RA_ML_06.html. (read 9.04.2014)
51. Oil spill from the Prirazlomnaya platform is a disaster for the region. 2012. Available from: <http://www.greenpeace.org/russia/ru/news/2012/August/14-080-2012-razliv-nefti-na-Prirazlomnoy-stanet-katastrofoy/>. Разлив нефти на платформе «Приразломная» грозит региону непоправимой катастрофой. 2012
52. Questor 10.1 (calculations are based on program’s databases from 2010)

18. LIST OF APPENDICES

Appendix 1: Calculation of the total horizontal and vertical ice forces onto the GBS

Assume that we have a GBS (conical hull) with diameter $D = 108$ m at MWL (mean water level) operating in the Pechora Sea region with the extreme environmental conditions [Tab. A.1.1]:

Table A.1.1 – Extreme environmental conditions of the Pechora Sea chosen for calculations

Parameter	Return period (years)	Value
Ice thickness	100	1.3 m
Ice drift speed	Average	0.2 m/s
Ice strength (uniaxial compressive), σ_c	Average	1.37 MPa
Ice strength (flexural), σ_f	Maximum	520 KPa

Let's estimate the total ice load on the structures having vertical walls and sloping walls with slope angle α ranging from 20^0 (close to horizontal plane) to 70^0 (steep walls).

Vertical structures

Let's assume that the total ice force F is given by [see Chapter «Ice loads on fixed structures»]:

$$F = \sigma_c * D * h$$

The Korzhavin equation:

$$F = I * K * m * \sigma_c * D * h$$

Parameter suggested values:

$$I = 1.2, K = 0.6, m = 0.9, \sigma_c = 520 \text{ KPa}, D = 108 \text{ m}, h = 1.3 \text{ m}$$

Solution:

$$F = \sigma_c * D * h = 1.37 * 10^6 * 108 * 1.3 = 192.35 \text{ MN}$$

The Korzhavin equation:

$$F = I * K * m * \sigma_c * D * h = 1.2 * 0.6 * 0.9 * 1.37 * 10^6 * 108 * 1.3 = 124.64 \text{ MN}$$

Sloping structures (2D-elastic model)

Let's assume that the total horizontal (F_H) force per unit width is given by [see Chapter «Ice loads on fixed structures»]:

$$\frac{F_H}{D} = \sigma_f \left[\frac{\rho_w g h^5}{E} \right]^{1/4} C_1 + z h \rho_i g C_2$$

Where: D – diameter of the structure at MWL (mean water level), ρ_i – density of sea ice, ρ_w – density of sea water, g - acceleration due to gravity, h – ice thickness, E – Young's modulus of ice, C_1 and C_2 - coefficients depending on the slope angle and coefficient of the ice dynamic friction over the structure (μ), z – the height of rubble on the structure's slope.

$$C_1 = 0.68 \left(\frac{\sin \alpha + \mu \cos \alpha}{\cos \alpha - \mu \sin \alpha} \right)$$

$$C_2 = (\sin \alpha + \mu \cos \alpha) \left(\frac{\sin \alpha + \mu \cos \alpha}{\cos \alpha - \mu \sin \alpha} + \frac{\cos \alpha}{\sin \alpha} \right)$$

Parameter suggested values:

$D = 108$ m, $\sigma_f = 1.37$ MPa, $h = 1.3$ m, $\rho_w = 1023$ kg/m³, $\rho_i = 900$ kg/m³, $E = 9$ GPa, $z = 5$ m, $g = 9.81$ m/s², $\mu = 0.2$.

The calculations were performed in Microsoft Excel. The total horizontal ice loads onto the GBS with different slope angles and comparison of ice-breaking and ride-up forces are illustrated in Table A.1.2 and Figure A.1.1.

Table A.1.2 – Total horizontal ice loads onto the GBS with different slope angles

Slope angle α	C1	C2	Total Horizontal force F_H , N	Ice-breaking force, N	Ride-up force, N
20°	0,413608	0,972690	7076473	1047781	6028692
30°	0,597603	0,952218	7415697	1513892	5901805
40°	0,849080	1,016679	8452284	2150951	6301332
50°	1,242557	1,108829	10020208	3147734	6872474
60°	2,010121	1,219366	12649765	5092183	7557582
70°	4,448978	1,412131	20022799	11270471	8752328

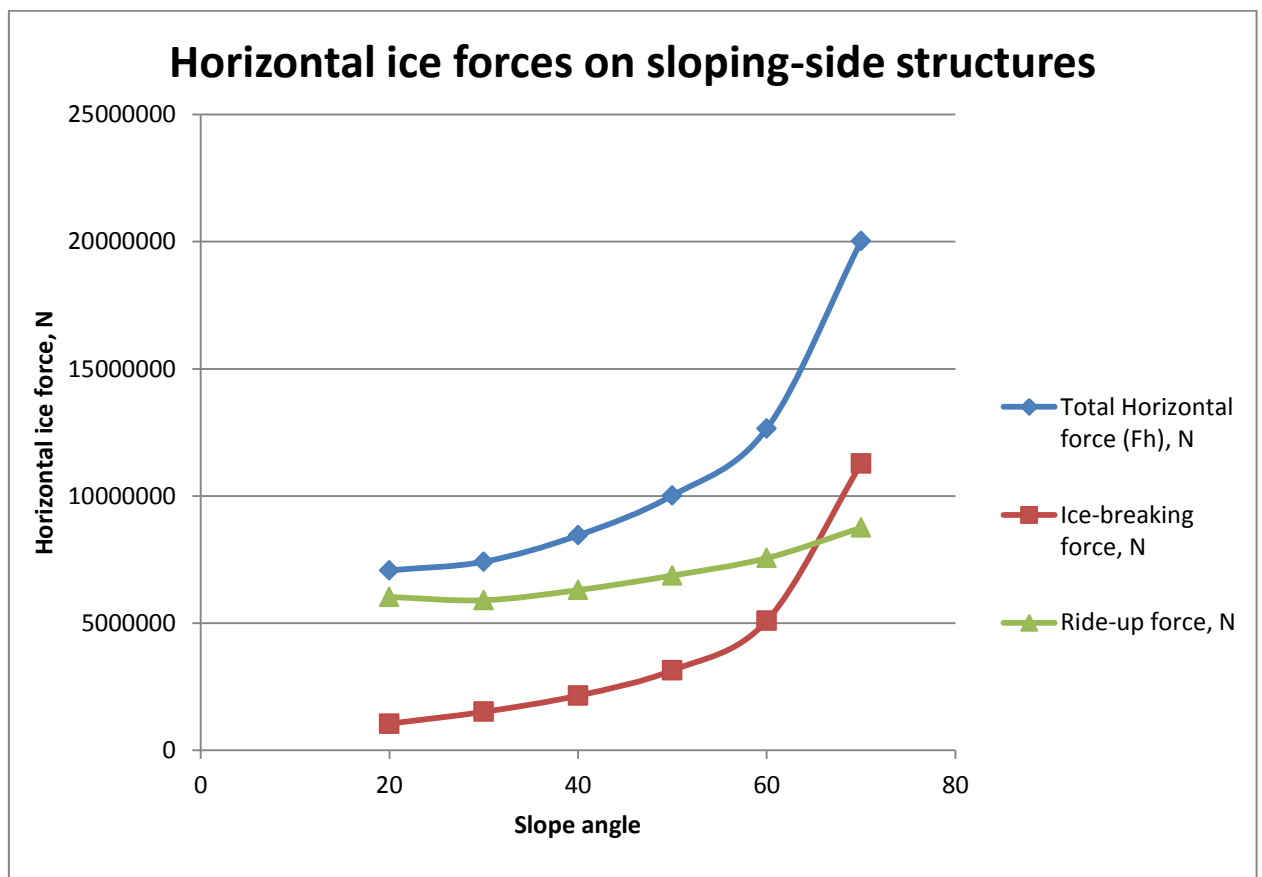

Figure A.1.1 – Total horizontal ice loads onto the GBS with different slope angles

Horizontal ice load for different slope angles due to adfreezing:

$$F_{adfreeze} = \frac{\pi h q W}{\tan \alpha}$$

Parameter suggested values:

$h = 1.3 \text{ m}$, $q = 0.3 \text{ MPa}$, $W = 108 \text{ m}$, α – from 20° to 70°

The results are illustrated in Figure A.1.2.

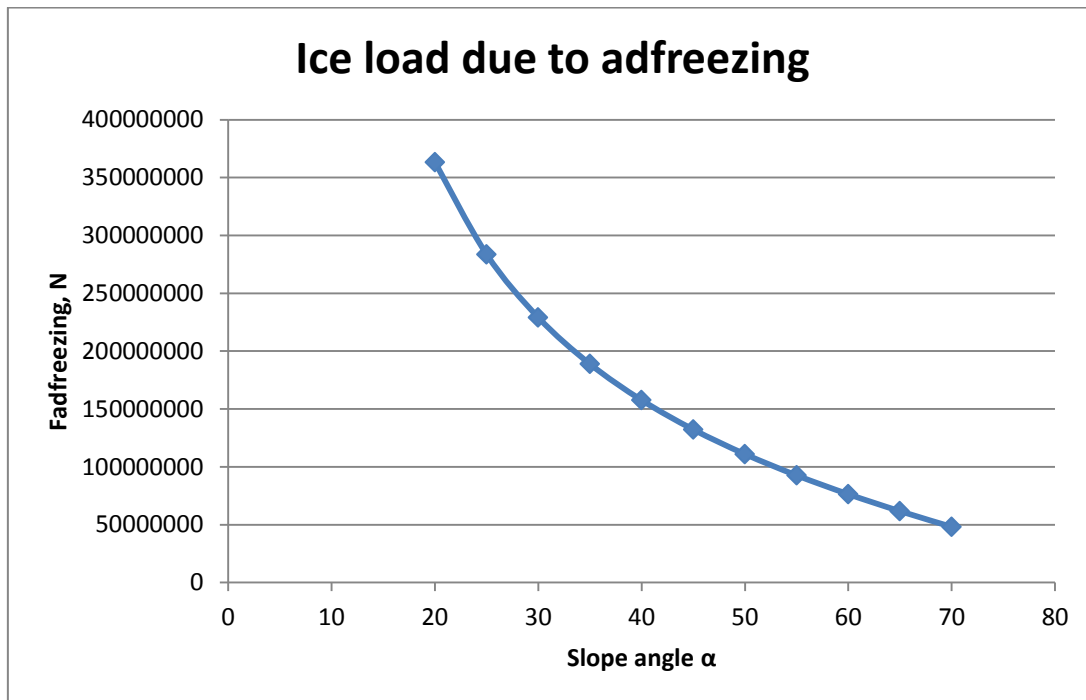

Figure A.1.2 – Horizontal ice load for different slope angles due to adfreezing

Conclusion:

We can see that the less steep slope provides the less horizontal ice load. For the structure with a steep slope the deck size will be close to the foundation size, but the steepness is limited, because there is a critical angle where the ice failure mode changes from bending to crushing. However, if the slope is too slight, the structure foundation size will be too big and its fabrication could be inefficient. For the most of slope angles the ride-up force is larger than ice-breaking force. The horizontal ice load due to adfreezing is smaller for the structures with steeper walls.

Appendix 2: Calculation of the ice ridge forces onto the GBS

Let's consider an interaction of the GBS form Appendix 1 with the ice ridge having the following parameters:

$$W_R = 57 \text{ m}, h_k = 15 \text{ m}, h_s = 3 \text{ m}, \rho_i = 900 \text{ kg/m}^3, c = 1 \text{ KPa}, \varphi = 45^\circ, n = 0.4$$

Other parameter suggested values:

$$D_e = 108 \text{ m}, \rho_w = 1023 \text{ kg/m}^3, g = 9.81 \text{ m/s}^2$$

For estimation of the first-year sea ice ridge loads on offshore structures several methods have been proposed. The methods vary widely and depend upon the structure geometry (vertical or sloped) and the assumed failure mode of the ice. This project work considers the estimation of ice ridge loads on vertical structures. The load from each part of the ridge formation can be considered separately and the total ridge force can be assumed as their sum. It is also assumed that the failure of one ridge part does not influence the failure of the other two. One more assumption is that there is no temporal difference amongst the failure of each component of the ridge.

Load due to the consolidated layer:

The consolidated layer force can be approximately found by using the Korzhavin equation [see Chapter «Ice loads on fixed structures»].

Let's take the same parameter suggested values as in Appendix 1, assuming that the thickness of the consolidated layer is equal to 100-year value of ice thickness in the Pechora Sea.

Parameter suggested values:

$$I = 1.2, K = 0.6, m = 0.9, \sigma_c = 520 \text{ KPa}, D = 108 \text{ m}, h = 1.3 \text{ m}$$

The Korzhavin equation:

$$F = I * K * m * \sigma_c * D * h = 1.2 * 0.6 * 0.9 * 1.37 * 10^6 * 108 * 1.3 = 124.64 \text{ MN}$$

Load due to the ridge keel and the ridge sail:

Local failure:

The Dolgopolov's formula (keel):

$$F_h = h_k D_e q \left(\frac{h_k \gamma_e \eta^2}{2} + 2\eta c \right) F_h = h_k D_e q \left(\frac{h_k \gamma_e \eta^2}{2} + 2\eta c \right)$$

$$\eta = \sqrt{\frac{1 + \sin \varphi}{1 - \sin \varphi}} \approx \tan\left(45^\circ + \frac{\varphi}{2}\right) \eta = \sqrt{\frac{1 + \sin \varphi}{1 - \sin \varphi}} \approx \tan\left(45^\circ + \frac{\varphi}{2}\right)$$

$$q = 1 + \frac{2h_k}{3D_e} \quad q = 1 + \frac{2h_k}{3D_e}$$

$$\gamma_e = (\rho_w - \rho_i)g(1-n) \quad \gamma_e = (\rho_w - \rho_i)g(1-n)$$

The Mellor's formula (keel and sail):

$$F_h = F_{h,k} + F_{h,s} \quad F_h = F_{h,k} + F_{h,s}$$

$$F_{h,s} = 0.5D_e\eta^2(1-n)\rho_i gh_s^2 + 2D_e c\eta h_s F_{h,s} = 0.5D_e\eta^2(1-n)\rho_i gh_s^2 + 2D_e c\eta h_s$$

$$F_{h,k} = 0.5D_e\eta^2(1-n)(\rho_w - \rho_i)gh_k^2 + 2D_e c\eta h_k F_{h,k} = 0.5D_e\eta^2(1-n)(\rho_w - \rho_i)gh_k^2 + 2D_e c\eta h_k$$

Global failure:

The Croasdale's formula (keel):

$$F_h = \frac{2}{3}W_R h_k^2 (\rho_w - \rho_i) g \tan \phi \quad F_h = \frac{2}{3}W_R h_k^2 (\rho_w - \rho_i) g \tan \phi$$

The total ice ridge load including the force due to the consolidated layer is presented in Table A.2.1.

Table A.2.1 – Ice ridge load on the structure estimated by different methods

Methods	Parameters	Values	F _h , MN	Total force, MN
Dolgoplov's theory	η	2.4142	64.56	189,20
	q	1.0926		
	Υ, Pa/m	723.9780		
Mellor's theory	F _{h,s} , MN	16.57	75.66	200,30
	F _{h,k} , MN	59.09		
Croasdale's theory			10.32	134,96

Conclusion:

The results vary significantly. The considered global load model gives lower ridge force values than the considered local load models. All methods used to determine failure forces of ridge keels, while the real failure mechanism could be different. Calculation results show that the consolidated layer creates the largest loads on a structure, but the results obtained by using the Korzhavin equation could be unrealistic due to many assumptions. Moreover, a lot of assumptions are used to determine the physical properties of the ice ridge and the ridge behavior during the interaction with structures.

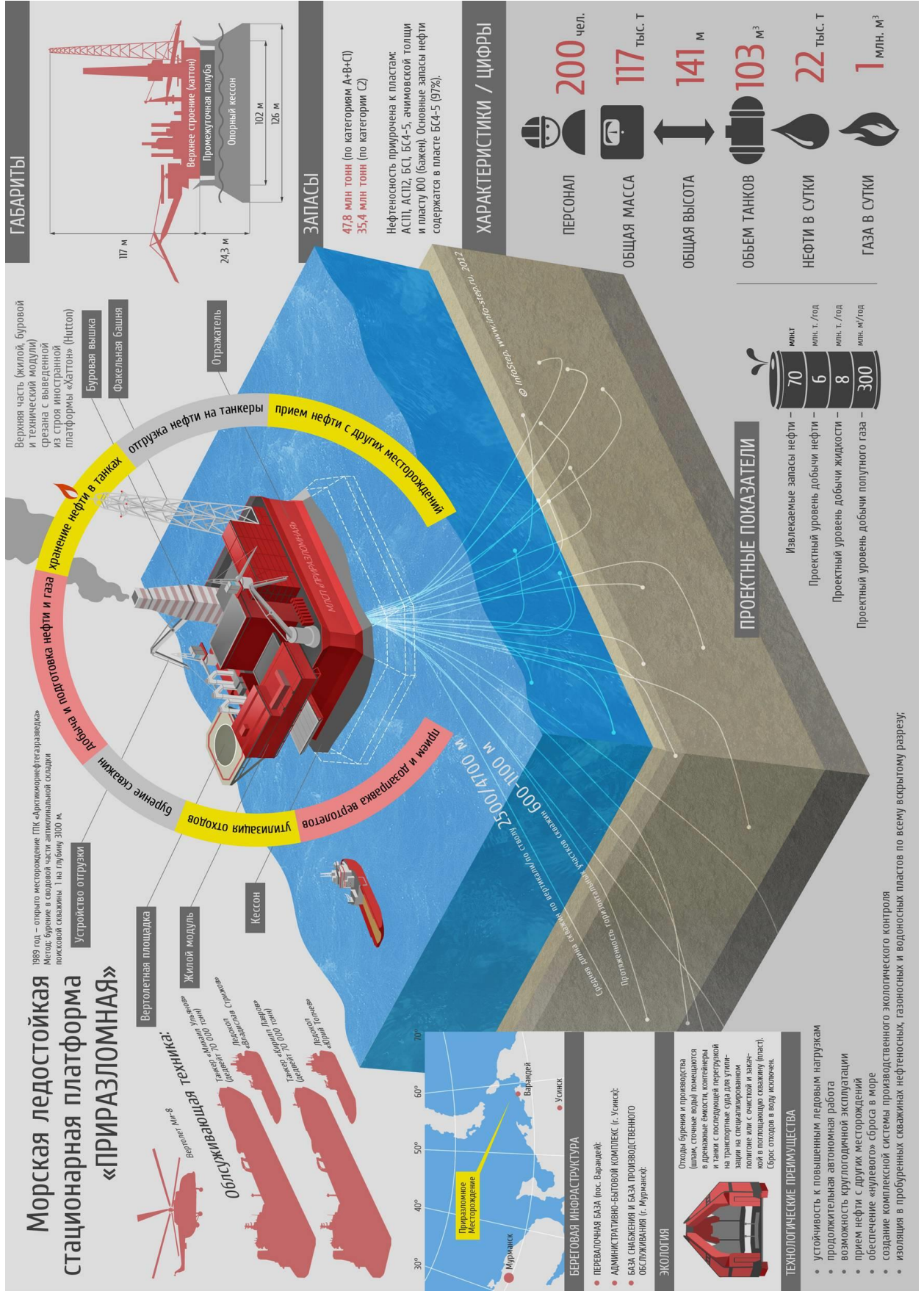

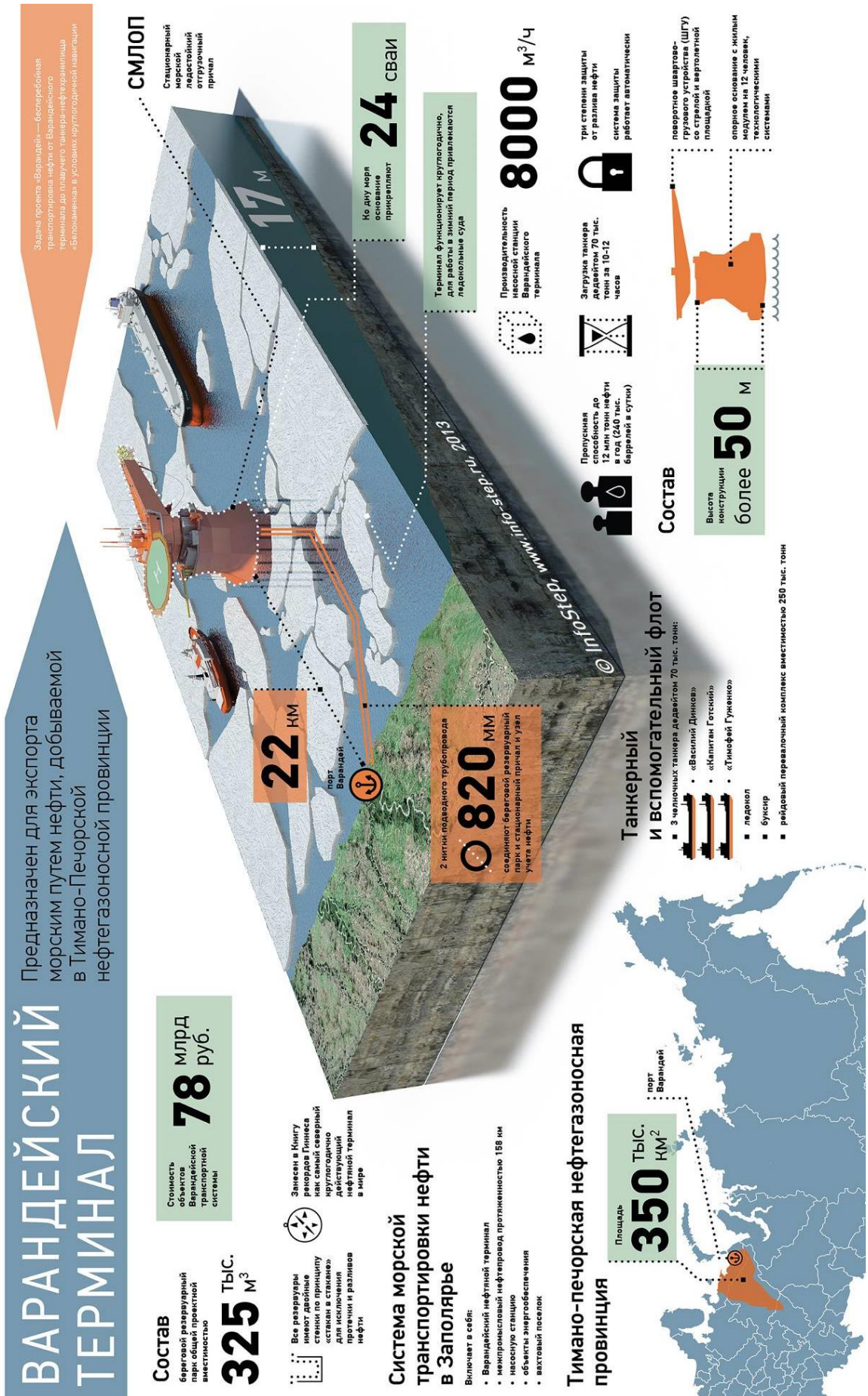

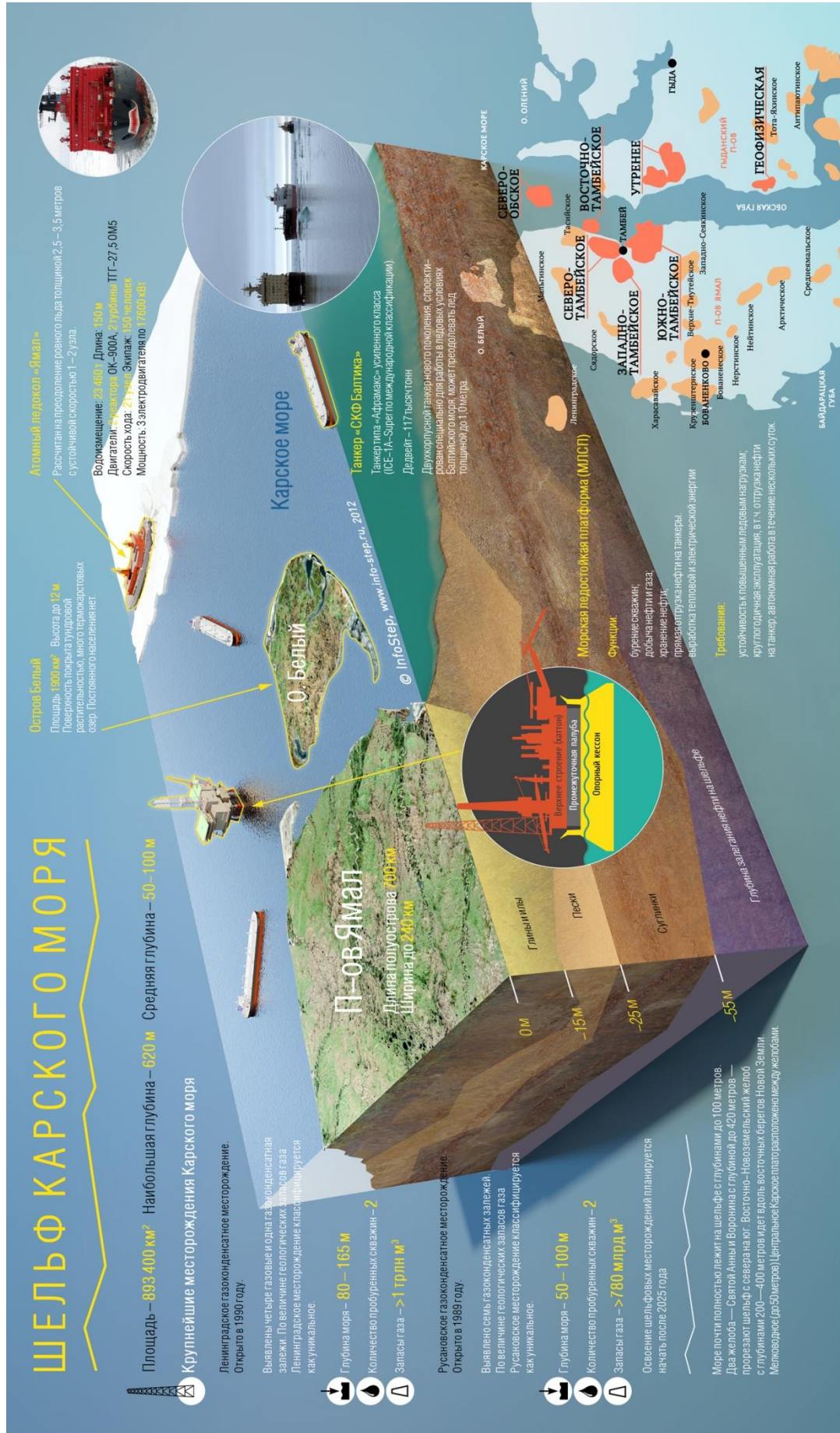

Table A.6.2 - Offshore cost summary for the Dolginskoye field ³⁴

OFFSHORE COST SUMMARY		Currency		US Dollars						
Project	New offshore project									
Location	C.I.S.									
Development type	Oil									
Sub total	3 411 847 000									
Contingency	516 432 000									
Owner's cost	0									
Grand total	3 928 279 000									
		Procurement strategy				Russia				
Cost centre	Totals	Equipment	Materials	Fabrication	Installation	H.U. & C.	Design	Project management	Ins. & cert.	Contingency
Topsides 1	916 752 000	265 949 000	86 193 000	111 645 000	73 139 000	73 978 000	157 690 000	32 763 000	32 054 000	83 341 000
Topsides 2	268 564 000	122 092 000	6 912 000	15 533 000	44 815 000	7 762 000	30 802 000	6 843 000	9 390 000	24 415 000
Topsides 3	271 238 000	122 092 000	9 249 000	15 533 000	44 815 000	7 762 000	30 802 000	6 843 000	9 484 000	24 658 000
GBS 1	260 766 000		63 305 000	90 263 000	34 500 000		23 188 000	6 776 000	8 721 000	34 013 000
GBS 2	155 976 000		33 659 000	47 919 000	27 100 000		16 864 000	4 872 000	5 217 000	20 345 000
GBS 3	155 976 000		33 659 000	47 919 000	27 100 000		16 864 000	4 872 000	5 217 000	20 345 000
Oil pipeline (offshore 1)	42 491 000		3 499 000		30 068 000		561 000	1 400 000	1 421 000	5 542 000
Two phase pipeline (offshore 2)	49 180 000		7 007 000		31 399 000		782 000	1 932 000	1 645 000	6 415 000
Water injection pipeline (offshore 3)	28 742 000		2 811 000		19 687 000		442 000	1 092 000	961 000	3 749 000
Two phase pipeline (offshore 4)	49 180 000		7 007 000		31 399 000		782 000	1 932 000	1 645 000	6 415 000
Water injection pipeline (offshore 5)	28 742 000		2 811 000		19 687 000		442 000	1 092 000	961 000	3 749 000
Offshore loading 1	129 875 000	56 369 000		557 000	5 540 000		13 600 000	28 000 000	4 163 000	21 646 000
Offshore drilling 2	529 146 000	95 170 000	121 651 000		201 809 000		2 397 000	2 968 000	16 960 000	88 191 000
Offshore drilling 3	496 058 000	90 813 000	112 985 000		188 517 000		2 312 000	2 856 000	15 899 000	82 676 000
Offshore drilling 1	545 593 000	97 326 000	125 938 000		208 455 000		2 431 000	3 024 000	17 487 000	90 932 000
TOTALS	3 928 279 000	849 811 000	617 243 000	328 812 000	988 030 000	89 502 000	299 959 000	107 265 000	131 225 000	516 432 000