



University of
Stavanger

Faculty of Science and Technology

MASTER'S THESIS

Study program/ Specialization: Offshore Technology/ Marine and Subsea Technology	Spring semester, 2014 Open
Writer: Dawit Berhe (Writer's signature)
Faculty supervisor: Prof. Daniel Karunakaran, Ph.D. (University of Stavanger, Subsea7 Norway) External supervisor(s): Dr. Dasharatha Achani Ph.D.(Subsea7 Norway)	
Title of thesis: CONTROLLED LATERAL BUCKLING DESIGN OF PIPELINES	
Credits (ECTS): 30	
Key words: Out-of-straightness, Snake-lay, ANSYS, Lateral buckling, Subsea pipelines, Virtual anchor, mode shapes, Residual curvature	Pages:101..... + Enclosure:78..... Stavanger, June 16, 2014 Date/year

ABSTRACT

Constrained high temperature and pressure pipelines (HPHT) are subjected to global buckling due to plane strain condition developed by virtual anchorage of soil friction resistance and subsea facilities. Any uncontrolled lateral buckling is a potential hazard for a pipeline's structural integrity, especially when whole compressive force is released at one point and excessive feed-in occurs.

The cost effective and elegant design solution is to work with the pipeline by letting it buckle in a controlled fashion and relieve some axial compressive force rather than trying to avoid buckling completely. There exist a number of mitigation methods which will allow the pipeline to buckle in a controlled manner. Snake-lay and residual curvature lay methods are such methods to initiate controlled buckling and are considered in the present thesis work.

The objective of the current work has been to design the selected pipelines under controlled lateral buckling by applying the above mentioned methods combined with trawl gear interaction. The selected pipelines for the work are 22" pipeline for snake-lay and 14" pipeline for residual curvature lay. The buckle initiation configurations were established based on the maximum allowable design feed-in into the buckle. The allowable design feed-ins of the selected pipelines were determined based on FE (Finite Element) analyses by modelling the pipes with given OOS (Out-of-Straightness) radii of the selected methods and combining trawl pull-over loads. The basis for estimation of the maximum allowable design feed-in is the pipeline capacity which was calculated based on the design criteria from DNV-OS-F110. In the current work, both load controlled and displacement controlled criteria have been considered for the analyses.

The work has been carried out by performing non-linear finite element analysis using a software ANSYS. The analyses include geometric and material non-linearities along with the pipe-soil interaction. The results based on both the analytical calculations and the FE analyses are presented and discussed against the relevant allowable design limiting criteria from DNV-OS-F101 and DNV-RP-F110.

The results from the analyses show that trawl interaction with subsea pipelines has a significant influence on the pipeline design when it is combined with the selected buckle initiation methods. The increase in rock volume is significant as the allowable feed-ins get reduced.

ACKNOWLEDGEMENT

This thesis work is to fulfill the requirement in the Master of Science degree in the Offshore Technology at the Department of Mechanical and Structural Engineering and Material Sciences, Faculty of Science and Technology in University of Stavanger, Norway.

First of all, I would like to express my sincere gratitude to my faculty supervisor Prof. Daniel Karunakaran (Adjunct Professor), for giving me the opportunity to work for the thesis under his supervision, and also for his advice, guidance and support.

I would especially like to thank Dr. Dasharatha Achani, my external supervisor from Subsea7, for his continuous support and instructions during this study. His guidance and help throughout the thesis work is highly appreciated.

I am pleased to acknowledge subsea 7 Rigid Pipeline discipline manager, Neil Brown and the discipline team for the assistance and providing friendly working environment.

I will also thank Subsea 7 in Stavanger for giving me the opportunity to write my thesis in their premises and providing me with office space, computer and additional software that was necessary to finalize this thesis work.

I would like to thank and express my gratitude to my beloved families for their support, encouragement and endless love throughout my studies.

Last but not least, I would like to express my sincere thanks for The Almighty God for giving me this opportunity and looking after me in every respect.

Dawit Berhe

Stavanger, June 16, 2014

NOMENCLATURE

LATIN CHARACTERS

D_i	Internal diameter of pipeline , [m]
D_o	Outer diameter of pipeline, [m]
A_i	Internal cross sectional area, [m^2]
A_e	External cross sectional area, [m^2]
A_{steel}	Cross sectional area of steel, [m^2]
E	Modulus of elasticity, [GPa]
EI	Flexural stiffness, [Nm^2]
F_{Hobbs}	Hobbs Critical buckling force, [N]
F_P	Maximum pull-over load on pipe in horizontal direction, [N]
f_T	Annual trawl frequency , [-]
f_y	Characteristic yield strength, [N]
f_u	Characteristic tensile strength, [N]
F_{max}	Maximum axial driving force, [N]
F_{OOS}	Force due to out-of-straightness, [N]
$f_{u,temp}$	De-raising tensile strength factor, [MPa]
$F_{y,temp}$	De-rating yield strength factor, [MPa]
I	Second Moment of Area
k_{mb}	Axial capacity factor based on engineering judgment, [-]
L_a	Anchor length, [m]
M_{SD}	Design moment, [Nm]
P_{cr}	Critical buckling force, [N]
P_e	External pressure, [MPa]
P_i	Internal pressure, [MPa]
P_{min}	Minimum internal pressure, [MPa]
P_o	Pre-buckle axial force, [N]
R	Lay radius, [m]
S_{SD}	Design Load, [N]
t	Pipe wall thickness, [mm]
T_{amb}	Ambient Temperature, [$^{\circ}C$]
ΔT	Change in temperature between installation and operation, [$^{\circ}C$]
U	Pipeline expansion, [m]
W_{sub}	Submerged weight, [N/m]
X65	Steel grade of 450MPa, [-]
Z	Active length to anchor point, [m]

GREEK SYMBOLS

α	Linear thermal expansion, [-]
γ_{SC}	Safety class, [-]
ε	Strain, [-]
ε_L	Longitudinal strain, [-]
ε_{SD}	Design strain, [-]
ν	Poisson's ratio, [-]
σ_b	Bending stress, [MPa]
σ_{endcap}	Stress at curvature, [MPa]
σ_{eq}	Equivalent stress, [MPa]
σ_h	Hoop stress, [MPa]
σ_l	Longitudinal stress, [MPa]
$\sigma_{thermal}$	Thermal stress, [MPa]
σ_u	Ultimate strength, [MPa]
σ_y	Yield strength, [MPa]

ABBREVIATIONS

ANSYS	Analysis system
BE	Best Estimate
DNV	DNV
FE	Finite Element
GPa	Giga Pascal
HP/HT	HP/HT
KN	KN
KP	KP
LB	Lower Bound
MPa	Mega Pascal
N	Newton
OOS	OOS
Pa	Pa
SMYS	Specified minimum Yield Strength
SMTS	Specified Minimum Tensile strength
UB	Upper Bound
VAS	Virtual anchor spacing
VAP ₁	Virtual anchor point at hot end
VAP ₂	Virtual anchor point at cold end

TABLE OF CONTENTS

1.	INTRODUCTION	1
1.1	BACKGROUND	1
1.2	BUCKLE INITIATION STRATEGIES	2
1.2.1	<i>Sleepers</i>	2
1.2.2	<i>Buoyancy</i>	2
1.2.3	<i>Expansion Spools</i>	3
1.2.4	<i>Snake-lay</i>	3
1.2.5	<i>Residual Curvature Lay:</i>	4
1.3	RESIDUAL CURVATURE LAY VERSUS SNAKE-LAY METHOD.....	5
1.4	TRAWL INTERACTION.....	6
1.5	PIPE-SOIL INTERACTION.....	7
1.6	THESIS OBJECTIVE	7
1.7	SCOPE OF WORK	8
1.8	OUTLINE OF THESIS	9
2.	THEORY OF PIPELINE BUCKLING.....	11
2.1	GENERAL.....	11
2.2	GLOBAL BUCKLING.....	12
2.2.1	<i>Effect of Thermal Strain</i>	13
2.2.2	<i>Effect of Pressure</i>	14
2.2.3	<i>Combined Effect of Thermal Strain and Pressure</i>	16
2.3	RESTRAINING FORCE.....	17
2.3.1	<i>General</i>	17
2.3.2	<i>End Expansion and Build-up of Effective Axial Force</i>	17
2.4	LATERAL BUCKLING	21
2.4.1	<i>Lateral Buckling Modes</i>	22
2.4.2	<i>Hobbs Analytical Method</i>	22
2.5	IN-SERVICE BUCKLING DESIGN CRITERIA	25
2.5.1	<i>Combined Local Buckling Design Criteria</i>	25
2.5.2	<i>Load Condition Factor</i>	27
2.6	FEED-IN ZONE	28
2.7	VIRTUAL ANCHOR SPACING	29
2.8	SUSCEPTIBILITY OF LATERAL BUCKLING.....	30
2.9	SHARING OF BUCKLES	32
3.	PIPELINE INSTALLATION METHODS.....	35

TABLE OF CONTENTS

3.1	INTRODUCTION	35
3.2	S-LAY	35
3.3	J-LAY	38
3.4	REEL-LAY	40
3.5	TOWING METHOD	42
4.	ASSESSMENT OF PULL-OVER LOADS AND DURATIONS	45
4.1	PULLOVER LOADS FOR TRAWL BOARD	45
4.2	PULL-OVER LOADS FROM CLUMP WEIGHT	46
4.3	PULL-OVER LOADS FOR BEAM TRAWLS	47
4.4	TRAWL PULL-OVER DURATION	47
4.4.1	<i>Trawl Board Pull-over Duration</i>	47
4.4.2	<i>Clump Weight Pull-over Duration</i>	48
4.4.3	<i>Beam Trawl Pull Over Duration</i>	49
4.5	LOAD COMBINATIONS BY TRAWL INTERFERENCE	50
5.	METHODOLOGY	53
5.1	GENERAL	53
5.2	DESIGN ASSUMPTIONS	53
5.3	FINITE ELEMENT ANALYSIS	54
5.3.1	<i>General</i>	54
5.3.2	<i>Finite Element Modelling</i>	54
5.3.3	<i>Geometry Modelling</i>	55
5.3.4	<i>Material Modelling</i>	58
5.3.5	<i>Seabed Modelling</i>	59
5.3.6	<i>Boundary Conditions and Load Steps</i>	59
6.	DESIGN DATA AND CASE STUDIES	61
6.1	DESIGN DATA	61
6.1.1	<i>Pipeline Data</i>	61
6.1.2	<i>Operational Data</i>	62
6.1.3	<i>Environmental Data</i>	62
6.1.4	<i>Pipe-Soil Interaction Data</i>	62
6.1.5	<i>Trawl Gear Data</i>	63
6.2	TEMPERATURE PROFILE	64
6.3	DNV-OS-F101 PIPE MATERIAL STRENGTH	65
6.4	CASE STUDIES	66
6.4.1	<i>22" Pipeline</i>	66
6.4.2	<i>14" Pipeline</i>	66

TABLE OF CONTENTS

7. RESULTS AND DISCUSSION FOR 22" PIPELINE: SNAKE-LAY	67
7.1 PIPELINE END EXPANSIONS	67
7.2 HOBBS ANALYTICAL METHOD	69
7.2.1 <i>Variation of Critical Buckling Force with Minimum Bend Radius</i>	75
7.3 SNAKE-LAY CONFIGURATION	76
7.3.1 <i>General</i>	76
7.3.2 <i>Snake-lay Configuration: Displacement Controlled Criterion</i>	77
7.3.3 <i>Snake-lay Configuration: Load Controlled Criterion (LCC)</i>	83
7.4 RESULTS FOR PULL-OVER LOADS AND DURATIONS	87
7.4.1 <i>Pull-over Loads and Duration for Clump Weight</i>	87
7.4.2 <i>Pull-over Force and Duration for Consumption Trawl Board</i>	87
7.4.3 <i>Pull-over Loads and Durations for Beam Trawl Board</i>	87
7.5 RESULTS FOR SNAKE-LAY WITH TRAWL INTERACTION	89
8. RESULTS AND DISCUSSION FOR 14" PIPELINE: RESIDUAL CURVATURE LAY	95
8.1 HOBBS SCREENING CHECK	95
8.1.1 <i>Residual Curvature under Load Controlled Criterion</i>	96
9. SUMMARY, CONCLUSIONS AND RECOMMENDATIONS.....	99
9.1 SUMMARY.....	99
9.2 CONCLUSIONS	99
9.2.1 <i>Snake-lay</i>	99
9.2.2 <i>Residual Curvature Lay</i>	100
9.3 RECOMMENDATION FOR FURTHER WORK	101

APPENDIX A: PREPARTION WORK

APPENDIX B: LATERAL BUCKLING VERIFICATION

APPENDIX C: ANSYS SCRIPT

APPENDIX D: END EXPANSION SCRIPT

APPENDIX E: RAMBERG-OSGOOD STRESS-STRAIN CURVE

APPENDIX F: PULL-OVER LOADS AND DURATIONS

APPENDIX G: DNV-OS.F101 CRITERIA CHECK

LIST OF FIGURES

Figure 1-1 Vertical triggers/sleepers (Harrison, et al., 2003)	2
Figure 1-2: Buoyancy elements to reduce weight (Harrison, et al., 2003)	3
Figure 1-3: Snake-lay configuration (Harrison, et al., 2003)	3
Figure 1-4: Pipe laying from a reel to the sea bed by introducing curvatures (Endal, 2005)	4
Figure 1-5: Pipeline over the Reel-lay vessel “Seaven Oceans” for residual curvature lay (Subsea 7, 2014)	4
Figure 1-6: Triggering mechanism of a global buckle (DNV, 2007)	6
Figure 2-1: End cap force at a curvature (Jee, 2013)	15
Figure 2-2: Poisson’s effect (Jee, 2013)	16
Figure 2-3: Development of virtual anchorage (Jee, 2013)	19
Figure 2-4: Effective axial force in a short pipeline (Palmer & Ling, 1981; Karunakaran, 2013)	20
Figure 2-5: Effective axial force versus pipeline length for long pipeline (Palmer & Ling, 1981; Karunakaran, 2013)	21
Figure 2-6: Typical Lateral Buckling Configuration (Einsfeld & Murray, 1984)	22
Figure 2-7: Lateral Buckling Modes (Hobbs, 1984)	22
Figure 2-8: Buckle Region (Kien, et al., u.d.)	28
Figure 2-9: Feed-in to a single buckle in an infinite pipeline (Kaye & Plamer, 1996)	28
Figure 2-10: Short pipeline Development (Jee, 2013)	29
Figure 2-11: Post buckling configuration (Carr, et al., 2011)	30
Figure 2-12: Sharing of Buckles, Basic Principle (DNV, 2007)	33
Figure 3-1: Typical S-lay pipe laying (Jee, 2006)	35
Figure 3-2: Schematic representation of S-lay pipeline installation and pipeline loading (Kyriakides & Corona, 2007)	37
Figure 3-3: Schematic representation of J-lay pipeline installation and pipeline loading (Kyriakides & Corona, 2007)	39
Figure 3-4: Technip’s Apache schematic representation of reeling method (Kyriakides & Corona, 2007)	40
Figure 3-5: Reel-lay Vessel Subsea7’s Seven Navica (Subsea7, 2012)	41
Figure 3-6: Schematic of surface tow method (Kyriakides & Corona, 2007)	43
Figure 3-7: Schematic of controlled depth tow method (Kyriakides & Corona, 2007)	43
Figure 3-8: Schematic of off-bottom tow method (Kyriakides & Corona, 2007)	43
Figure 3-9: Schematic of bottom tow installation method (Kyriakides & Corona, 2007)	43
Figure 4-1: Force-time history for Trawl boards pull-over force on pipelines (DNV, 2010)	48
Figure 4-2: Force-time relation for a Clump weight (DNV, 2010)	49
Figure 4-3: Force-time relation for Beam trawl pull-over force on pipeline (DNV, 2010)	50
Figure 5-1: Pipeline finite element model	54
Figure 5-2: PIPE288 geometry (ANSYS, 2009).	55
Figure 5-3: Pipeline model (PIPE288) element in ANSYS	55

LIST OF FIGURES

Figure 5-4: Configuration of residual curvature as an initial imperfection	56
Figure 5-5: FE model to strain the pipe for residual curvature	57
Figure 5-6: FE Model after pipe strained for residual curvature	57
Figure 5-7: Ramberg-Osgood stress-strain curve of base material of the pipe	58
Figure 5-8: Stress-Strain Characteristics of 14" pipeline including clad material	59
Figure 6-1: C_h coefficient for effect of span height on impact velocity (DNV, 2010)	63
Figure 6-2: Temperature profile for 10km pipeline of 22"	64
Figure 6-3: De-rating of yield strength values (DNV, 2013)	65
Figure 6-4: De-rated yield strength of Pipe material X65	65
Figure 7-1: Effective axial force for 10km pipeline	69
Figure 7-2: Hobbs critical buckling force for each mode for 22" pipeline	70
Figure 7-3: Effective axial driving force and Hobbs critical buckling forces	72
Figure 7-4: Buckle driving force due to friction coefficients	73
Figure 7-5: Hobbs critical buckling force versus lateral friction coefficient	74
Figure 7-6: Force due to OOS versus soil friction coefficients	75
Figure 7-7: Variation of critical buckling force with minimum bend radius	76
Figure 7-8: Effective axial force distribution for 22" pipeline	79
Figure 7-9: Expansion distribution for 22" pipeline	80
Figure 7-10: Effective axial driving forces and the pre-determined snakes distribution	82
Figure 7-11: Effective axial force distribution for 22" pipeline	85
Figure 7-12: Expansion distribution for 22" Pipeline	86
Figure 7-13: Horizontal trawl loads for Beam trawl, Consumption trawl board and Clump weight	88
Figure 7-14: Vertical trawl loads for Clump weight and Consumption trawl board	89
Figure 7-15: Effective axial force distribution for 22" pipeline considering trawl interference	93
Figure 7-16: Expansion distribution for 22" pipeline considering trawl interference	94
Figure 8-1: Hobbs critical buckling force for each mode for 14" pipeline	96
Figure 8-2: Results for equivalent plastic strain	97
Figure 8-3: Results for equivalent total elasto-plastic strain	98
Figure 8-4: Results for lateral displacement	98

LIST OF TABLES

Table 2-1: Lateral buckling coefficients (Hobbs, 1984)	24
Table 4-1: Load combinations (DNV, 2007)	50
Table 4-2: Trawl pull-over loads characteristics (DNV, 2007)	51
Table 6-1: Pipeline data	61
Table 6-2: Operational data	62
Table 6-3: Environmental data	62
Table 6-4: Friction coefficients	62
Table 6-5: Trawl gear data (DNV, 2010)	63
Table 7-1: Results for end expansion for 10km pipeline for varying axial friction	68
Table 7-2: Hobbs critical buckling forces	70
Table 7-3: Buckling force due to OOS radius of R=2000m	71
Table 7-4: Buckling force due to OOS radius of R=1500m	71
Table 7-5: Allowable feed-in for different soil friction coefficients	78
Table 7-6: Snake configuration for 22" pipeline	81
Table 7-7: Allowable feed-in for different soil friction coefficients	84
Table 7-8: Snake Configuration for 22" pipeline	84
Table 7-9: Load history curves for Clump weight	87
Table 7-10: Load history for Consumption trawl board	87
Table 7-11: Load history for Beam trawl	88
Table 7-12: Allowable feed-in and trawl gear types with 90 degrees angle of attack	90
Table 7-13: Allowable feed-in with 30 and 60 degrees of angle of attack	91
Table 7-14: Allowable feed-in for different soil friction coefficients	91
Table 7-15: Snake Configuration for 22" pipeline considering trawl interference	91
Table 8-1: Hobbs critical buckling forces for 14" pipeline	95
Table 8-2: Allowable feed-in for different soil friction coefficients	97

1. INTRODUCTION

1.1 Background

Offshore pipelines have become the unique means of efficiently transporting petroleum fluids. Today's offshore pipelines are major structures with costs that run in the hundreds of millions. Thus, they require to be designed with the care and attention and to be designed to safely sustain the installation, operational and various off-design conditions. Each of these conditions provides several design scenarios. Global buckling of subsea pipelines under thermal heating and internal pressure is one of the most important design scenarios to be considered in pipeline design.

Most pipelines installed recently operate at relatively High Pressure and High Temperatures (HP/HT). Normally pipelines exposed to high temperature and pressure will experience axial compressive force which may cause the pipeline to buckle globally. It is important to assure the integrity of pipeline with a potential for global buckling.

Global buckling assessment is determination of the susceptibility of the pipeline to experience lateral buckling, upheaval or upheaval combined with lateral buckling due to temperature and pressure. A pipeline may buckle laterally as seabed friction builds up frictional force to resist the axial expansion which causes the pipeline to experience axial compressive force. And the magnitude of this compressive force depends on the extent of constraint applied to oppose the expansion. It means the presence of high axial friction will set up high compressive force.

Lateral buckling can occur in a pipeline when the compressive force in the pipeline is relieved at an imperfection. When all the compressive force is released at one point of imperfection, excessive feed-in occurs into the buckle already formed at that point. Finally, this leads to uncontrolled lateral buckling causing the pipeline failure and rupture which is a potential hazard for a pipeline's structural integrity. Hence, it is required to design the pipeline using a robust buckle formation strategy to initiate buckling at a controlled spacing.

This thesis work deals with the pipeline to buckle in planned and controlled manner. The work considers controlled lateral buckling design using snake-lay and residual curvature lay methods combined with trawl gear interaction.

1.2 Buckle Initiation Strategies

Inherent imperfection due to the pipeline route or gradient can provide sufficient out of straightness to initiate buckles but this might not be enough to trigger sufficient number of buckles at low axial compressive force. A number of initiation strategies have been proposed to control and mitigate lateral buckling. Some of the methods that are commonly used in the industry are discussed below.

1.2.1 Sleepers

Introducing the sleepers along the pipeline (shown in Figure 2-1) is proposed as one of the methods to initiate buckling. The sleepers are pre-laid across the pipeline. The pipeline on the each side of the sleeper is suspended above the seabed and it, therefore, experiences no frictional restraint at the location of the sleepers.

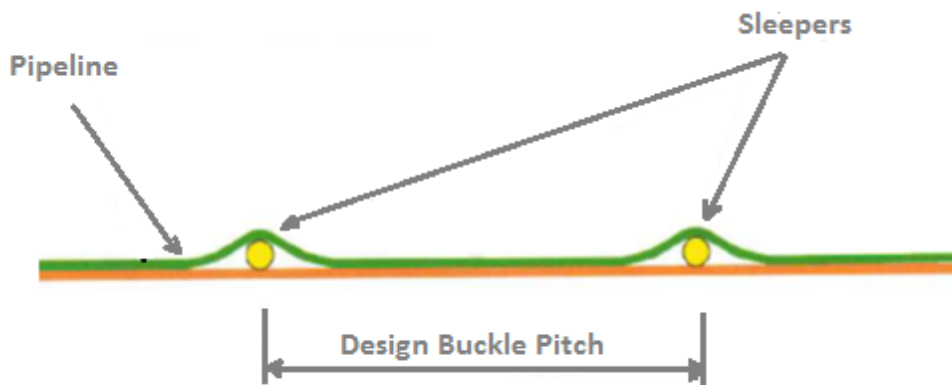

Figure 2-1 Vertical triggers/sleepers (Harrison, et al., 2003)

1.2.2 Buoyancy

The buckle initiation is also possible through introducing buoyancy. In this method of buckle initiation, the additional buoyancy is installed at discrete lengths of the pipeline to lift it off the seabed as seen in Figure 2-2. Using this method, sufficient out of straightness in the pipe near the buoyancy can't be ensured. In addition, the concern with this method is to encourage buckling at the planned location of buoyancy.

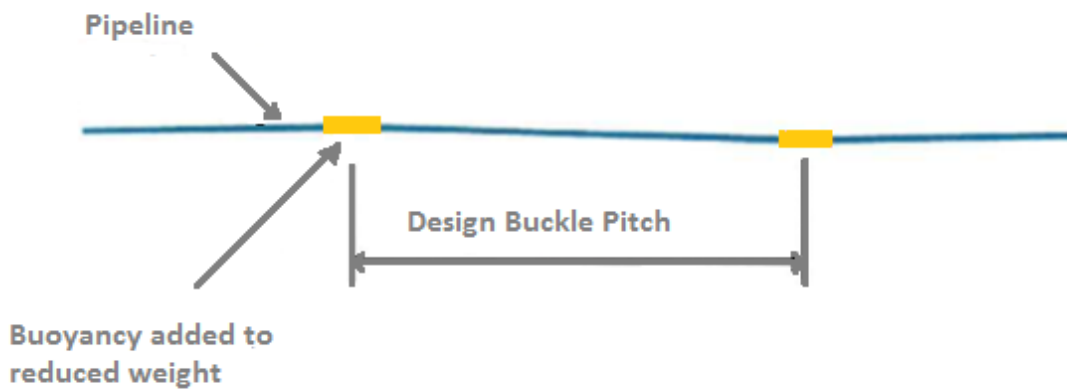

Figure 2-2: Buoyancy elements to reduce weight (Harrison, et al., 2003)

1.2.3 Expansion Spools

Expansion spools are more widely used to connect pipelines to risers through tie-in. In addition, they also serve the purpose of absorbing pipeline end expansion. It acts at the same time as a compression relief points so that lateral buckling can be initiated.

1.2.4 Snake-lay

Snake-lay configuration is one of the methods to initiate buckles along the pipeline. The method involves laying the pipeline with a number of large radius bends with some predetermined curves along the lay center line as shown in Figure 2-3. The aim of snake-lay is to provide an over length of the pipeline within the curves which will absorb the expansion of the pipeline and the feed-in is limited to be within the allowable feed-in length.

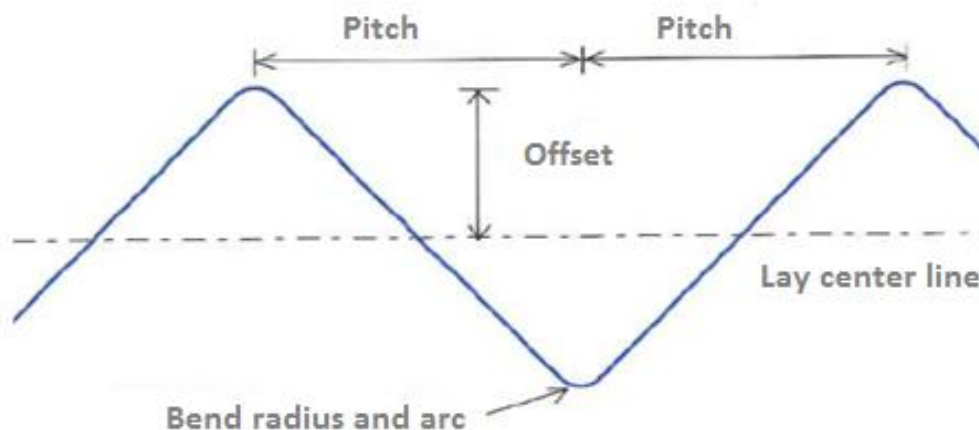

Figure 2-3: Snake-lay configuration (Harrison, et al., 2003)

1.2.5 Residual Curvature Lay:

The concept of the residual curvature method is similar to the snake-lay mitigation of lateral buckling where the pipeline is allowed to buckle in a controlled manner at pre-determined locations. The main principle is based on basically creating distributed residual curvatures at constant intervals along the pipeline so that buckling can be initiated at the purposely constructed residual curves. The residual curves provide sharing of expansion in the pipeline and thus this method can be used as an alternative measure to mitigate lateral buckling.

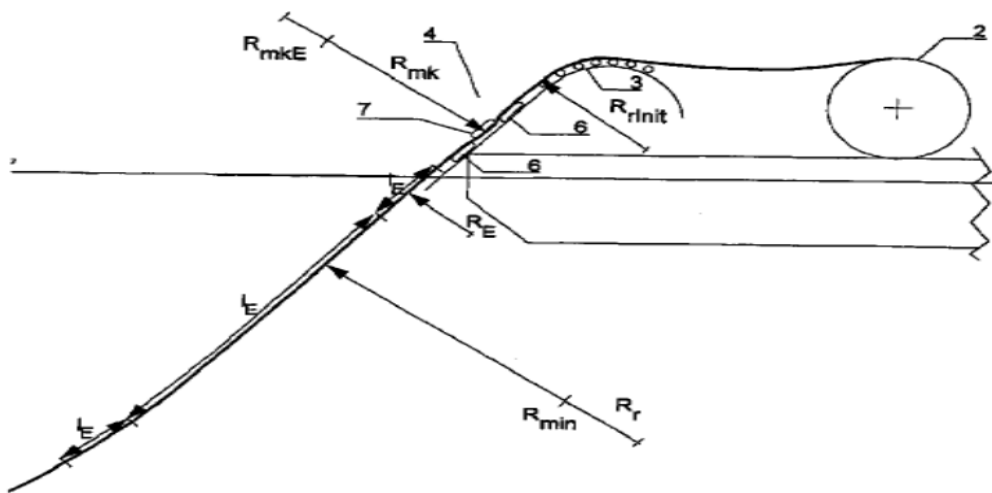

Figure 2-4: Pipe laying from a reel to the sea bed by introducing curvatures (Endal, 2005)



Figure 2-5: Pipeline over the Reel-lay vessel "Seaven Oceans" for residual curvature lay (Subsea 7, 2014)

Figure 2-4 from Endal (2005) illustrates how the residual curvatures are introduced in a pipeline. Figure 2-5 shows a reel-lay vessel from Subsea 7, which is used for residual curvature lay. It is seen from Figure 2-4 that a pipeline with initial residual curvature is feed out from a reeled pipeline to a curvature device where a reversed radius of curvature is applied to the opposite side of the initial curvature when the pipeline passing through the device. It can be said that the locations with residual curvature will form expansion loops during laying operation and they absorb the expansion of the pipeline under operating pressure and temperature. The curvature device straightens out the sections that are having a radius of curvature larger than the minimum predesigned curvature. This facilitates the pipeline laid on the seabed to have straight sections with intermittently placed residual curvature sections.

1.3 Residual Curvature Lay versus Snake-lay Method

The difference of this method compared the snake-lay method is the way the pipeline installed. The important features are summarized below.

- The residual curvature lay is more economical as it is faster than the snake-lay method. Because, it takes less vessel time as the residual curvatures are created by curvature device while the pipeline is feeding out from the vessel and the feed-out is continuous. On the other hand, in snake-lay method, the pipeline feed-out is stopped while bending the pipeline with the laterally arranged pistons on the seabed (Endal, 2005).
- In Snake-lay method, the pipeline can be laid with larger snake radius, but in the residual curvature lay method the order of the radius of the residual curves can be very small.
- This method is applicable only in reel-lay so that it has limited capacity with respect to the diameter of the pipeline. For example, the capacity of the Subsea 7 reel-lay vessel (“Seven Oceans” shown in Figure 2-5) is currently up to 16 inches in diameter.
- This method avoids plastic straightening of the residual curved sections due to applied axial tension. Due to pure axial tension, the residual curves will only be straightened out elastically without plastic expansion. This is achieved by applying an equal counterbalancing or straightening moment on the entire pipeline (Endal, 2005).

1.4 Trawl Interaction

Trawling activity routinely interferes with pipelines at all locations along the pipeline length. This is therefore a design condition for any pipeline that is exposed on the seabed.

According to DNV-RP-F110 (2007), for the global buckling assessment two activation mechanisms shall be considered. Figure 2-6 below shows the activation of buckling by external interference from trawl pull-over and initial random imperfection (out-of-straightness) from laying.

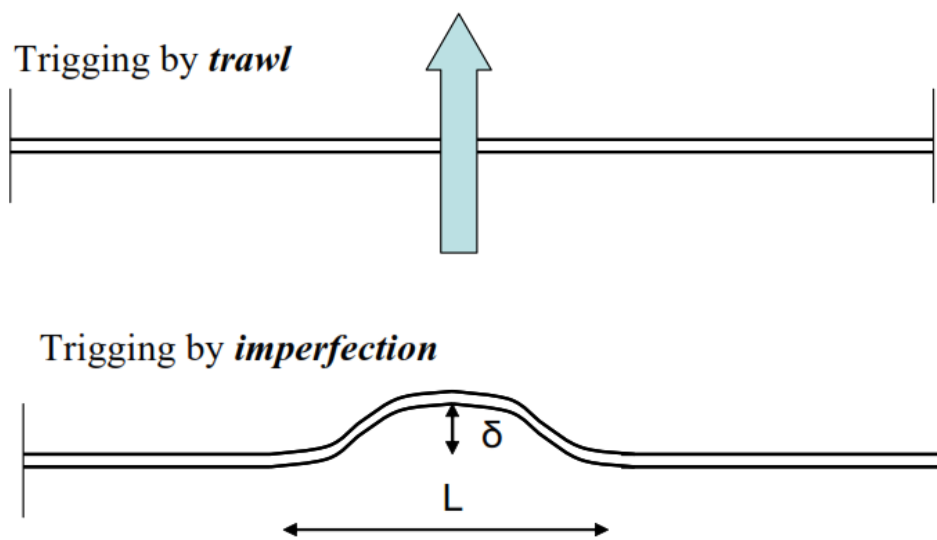

Figure 2-6: Triggering mechanism of a global buckle (DNV, 2007)

There are three main interaction effects due to trawl gear passing over the pipelines. The first is the impact when the gear first comes into contact with the pipeline. This is similar to a dropped object impact and can result in a dent. The second effect is the pull-over force as the gear is pulled over the top of the pipeline. This can drag the pipeline and bend it, and in extreme cases can result in local buckle. The third effect is hooking of fishing gear on the pipeline. In other words, the gear passes under the pipeline and becomes entangled to the point where it comes fast (DNV, 2007).

The present work considers pull over loads from Trawl boards, Clump weight and Beam trawl, commonly used for the North Sea and Norwegian Sea, in the lateral buckling design of the selected pipeline.

1.5 Pipe-soil Interaction

Pipe-soil interaction is one of the significant factors that affect the global buckling characteristics of subsea pipeline. However, there is a large uncertainty in the characteristics of the soil material at the sea floor and its variation along and around the length of the pipeline (DNV, 2007). The coefficient of friction between the pipeline and the soil develops a force that act against the movement of the pipeline longitudinally and laterally. However, the determination of the coefficient of friction depends on various factors such as soil and pipe characteristics.

According to DNV-RP-F110 (2007), pipe-soil interaction is highly dependent on the buckling mode and the components of the pipe-soil interaction involved in the potential buckling modes of the pipeline are:

- i. The downward stiffness is important for smoothening of survey data and for upheaval buckling design.
- ii. The lateral stiffness is important for later buckling; and affects both mobilization and post buckling configurations.
- iii. Axial stiffness is relevant for when any buckling mode is triggered as it affects the post buckling mode.
- iv. Upward pipe-soil interaction during up-lift is relevant for upheaval buckling analysis

Pipeline-soil interaction mobilizes frictional force which influences to high degree buckling and expansion designs of a subsea pipeline. Depending on the criticality of the buckling design, design formulas and parameters for pipe-soil interaction should be evaluated before their selection for relevance and accuracy on the basis of engineering judgments, relevant experience, correlation and sensitivity analysis (DNV, 2007).

1.6 Thesis Objective

The main objective of the thesis is to design a controlled lateral buckling using snake-lay and residual curvature lay combined with trawl gear interaction. The following goals and objectives are associated with the thesis:

- To study and understand the methodology used for global buckling design of pipelines described in DNV-RP-F110.

- To review the existing buckle formation/initiation strategies for the pipeline design under controlled buckling
- To assess the effect of fishing gear interaction with subsea pipeline
- To review the design methodology of snake-lay and residual curvature lay for the pipeline design under controlled lateral buckling by following the guidelines from DNV-OS-F101 and DNV-RP-F110.
- To perform FE analyses to identify the allowable design feed-in by modeling the chosen pipelines with the selected buckle formation strategies together with trawl pull over loads.
- To establish snake-lay and residual curvature configurations considering trawl interaction
- To present the results from both analytical calculations and finite element analyses and discuss against the design criteria from DNV-OS-F101 and DNV-RP-F110.

1.7 Scope of Work

This thesis discusses global buckling of submarine pipelines subjected to high temperature and pressure. Trawl impact interaction with pipeline was also considered. It includes literature review and simulation using general finite element software ANSYS. In this thesis work, a design methodology against lateral buckling is explored by allowing the pipeline to buckle in a controlled fashion. The use of snake-lay configuration and residual curvature method as buckling triggering and mitigation methods for lateral buckling are briefly discussed. These methods are basically based on laying the pipeline with some predetermined and deliberate horizontal curves to initiate a number of controlled buckles at a pre-determined location along the pipeline. These methods, if necessary, includes the application of intermittent rock dumping along the length of the pipeline to control the end expansions at both hot and cold ends and to increase the axial restraint of the pipeline to limit the feed-in to the predetermined buckles.

The structural capacity of the pipeline will determine its feed-in capacity for the snake-lay and residual curvature lay configurations. In this thesis work, the capacity shall be calculated for both displacement controlled criterion (DCC) and load controlled criterion (LCC) in accordance with DNV-OS-F101. The allowable feed-in length shall be calculated in accordance with DNV-RP-F110. The scope includes developing separate FE models for the two selected buckle initiation methods and performing analyses for controlled and planned

lateral buckling design. The results from both analytical calculations and finite element analyses are presented and discussed against the design criteria.

1.8 Outline of Thesis

Chapter 2: Theory of Pipeline Buckling

This chapter deals and summarizes the general theoretical background of pipeline buckling design issues. It includes literature review and design aspects for global and lateral buckling.

Chapter 3: Pipeline Installation Methods

This chapter discusses briefly on the various types of pipeline installation methods. It presents some of the advantages and disadvantages of the methods.

Chapter 4: Assessment of Trawl Pull-over Loads and Durations

This chapter discusses and provides DNV pull-over loads and durations for different types of trawling gears. All the input data for the calculation and the analyses are according to DNV-RP-F111.

Chapter 5: Design Methodology

This chapter discusses the design methodology used in the thesis work. It also gives the description of FE modeling of pipeline and seabed.

Chapter 6: Design Data and Case Studies

This chapter defines case studies need to be conducted. It provides all the necessary input data including pipe material property, soil data and environmental data to perform the finite element analyses.

Chapter 7: Results and Discussion for 22” pipeline: Snake-lay Method

This chapter presents and discusses the results for 22” pipeline under Snake-lay Method. The results include from both analytical calculations and finite element analyses. The FE analyses are based on both load and displacement controlled design criteria.

Chapter 8: Results and Discussion for 14” pipeline: Residual Curvature Method

This chapter presents and discusses the results for 14” pipeline under Residual Curvature Method. The results include from both analytical calculations and finite element analyses. The FE analyses are based on load controlled design criterion.

Chapter 9: Conclusion and Recommendation for Further Work

This chapter summarizes the results of the analysis and states the conclusions of the current work based on the results and further lists the recommendations for further work is made.

2. THEORY OF PIPELINE BUCKLING

2.1 General

Global buckling is a common phenomenon observed in high temperature and pressure submarine pipelines (HPHT) mainly due to the compressive axial force developed with increase in operating temperature of the pipeline. Normally pipelines are constrained in the longitudinal direction by subsea facilities, rock dumping and soil friction resistance. For an increase in temperature from the ambient condition the pipeline tries to expand and this will result in compressive axial force due to plane strain condition. If this axial load increases beyond a critical value called buckling axial force, results in global buckling of the pipeline.

Offshore subsea pipelines are designed to safely sustain installation and operational loads and survive various off design conditions, and each one of these lead to different design scenarios. Load imposed unacceptable structural effects should be avoided or minimized to an acceptable level by adopting optimum design alternatives so that the installed pipelines will be able to serve the intended purpose properly within all design premises i.e. human and environment safety, cost minimizing, fulfilling prevailing design standard and specifications (Kyriakides & Corona, 2007).

Buckling describes as a process of changing from a straight and stiff configuration to the bent one that has very small stiffness. The load at which this change occurs is called critical buckling load (Kyriakides & Corona, 2007).

Global buckling is not a failure mode rather a load response which can imply other failure modes such as local buckling, fracture, fatigue, etc. In accordance with DNV-OS-F101, the global buckling, for example is designed by limiting local buckling. It will however be discussed later that controlled lateral buckling can be beneficial to relief part of the axial compressive load developed in the pipeline.

Generally, buckling is caused due to external pressure, bending, axial forces, thermal forces, excessive bending at touch down points, accidental and environmental loads. Buckling is initiated due to a combination of longitudinal, bending and hoop stresses.

Pipeline buckling design and analyses can be done based on the limit state design criteria (DNV, 2013): Load controlled criterion (LCC) or displacement controlled criterion (DCC).

These design criteria has been used in the present work and described in the subsequent sections.

2.2 Global Buckling

Global buckling is a common phenomenon observed in high temperature and pressure submarine pipelines (HPHT) mainly due to the compressive axial force developed with increase in operating temperature of the pipeline. Normally pipelines are constrained in the longitudinal direction by subsea facilities, rock damping and soil friction resistance. For an increase in temperature from the ambient condition the pipeline tries to expand and this will result in compressive axial force due to plane strain condition. If this axial load increases beyond a critical value called buckling axial force, results in global buckling of the pipeline.

Global buckling is a load response and it is not considered as a failure mode by itself but it can lead to other failure modes, such as local buckling, fracture and fatigue, and can reduce the axial capacity of the pipelines (DNV, 2007).

High pressure and high temperature pipelines are expected to experience global buckling mainly due to (DNV, 2007):

- High effective compressive stress
- Low compressive capacity of pipeline
- Low pipe-soil resistance
- Light weight pipelines

The magnitude of the axial force to initiate global buckling generally depends on the following factors (DNV, 2007):

- Pipe cross sectional properties
- Lateral resistance
- Imperfection i.e. out of straightness on the pipeline
- Lateral buckling triggering force

To ensure a reliable, efficient, and cost effective design, the design of pipelines for global buckling should include the following important design consideration (DNV, 2007):

- Structural response modeling
- Pipeline route modeling.
- Soil-pipe interaction modeling.

There are three main factors contributing to end forces and expansion (Palmer & Ling, 1981):

- Thermal strain
- Pressure
- Poisson contraction associated with pressure effects

2.2.1 Effect of Thermal Strain

Pipelines experience thermal strain or thermal stress when subjected to temperature difference during operation phases. The pipeline will be installed at ambient temperatures, but will operate at higher temperatures. Expansion is therefore due to this increase in temperature. When the pipeline is unrestrained, the increase in temperature causes expansion of pipeline length. Whereas when it is totally constrained, the pipeline cannot expand and therefore the effects can be seen as a compressive stress in the pipe.

The thermal strain is given as (Palmer & Ling, 1981):

$$\varepsilon_{thermal} = \alpha \cdot \Delta T \quad (2-1)$$

Where: $\varepsilon_{thermal}$: Thermal strain

α : Linear thermal expansion coefficient

ΔT : Change in temperature between installation and operation.

The thermal stress is given by:

$$\sigma_{thermal} = -\alpha E_{steel} \cdot \Delta T \quad (2-2)$$

Where: $\sigma_{thermal}$: Thermal stress

E_{steel} : Elastic modulus

A pipeline which is fully constrained experiences buckling when it is exposed to increase in temperature during operation. Any imperfection or out of straightness (OOS) in the pipeline initiate thermal buckling of the pipeline.

The imperfection will create a perpendicular component of the axial compressive force induced by operational/design temperature of the pipeline. Then the pipeline will start to move side-ways if the perpendicular force exceeds the soil frictional restraining force.

2.2.2 Effect of Pressure

Pressure induces axial loading due to end cap force which contribute to the expansion of pipeline. At the same time there will be a Poisson contraction, where a contraction effect is observed due to hoop pressure acting in opposite direction to end cap force (Palmer & Ling, 1981).

The first pressure effect is the end cap loading and this occurs at any curvature in the pipeline. The end-cap force which is caused due to pressure difference is given as (Jee, 2013):

$$F_{end\ cap} = \Delta P \cdot A_i \quad (2-3)$$

$$\Delta P = P_i - P_e \quad (2-4)$$

$$A_i = \frac{\Pi}{4} \cdot D_i^2 \quad (2-5)$$

Where:

F_{endcap} : Force at curvature end of pipeline

ΔP : Change in pressure across pipe wall

P_i : Internal pressure

P_e : External pressure

A_i : Internal cross-sectional area of pipeline

D_i : Internal diameter of pipeline cross section

The corresponding stress for unrestrained pipeline is given as (Jee, 2013):

$$\sigma_{end\ cap} = \frac{F_{end\ cap}}{A_{steel}} \quad (2-6)$$

And the corresponding strain is:

$$\varepsilon_{end\ cap} = \frac{\sigma_{end\ cap}}{E_{steel}} \quad (2-7)$$

Where:

$\sigma_{end\ cap}$: Stress at curvature end of pipeline

A_{steel} : Area of steel

$\varepsilon_{end\ cap}$: Strain at curvature end of pipeline

If the pipeline is restrained, naturally the end cap force is balanced by the boundary restraining forces and hence no resultant end-cap forces.

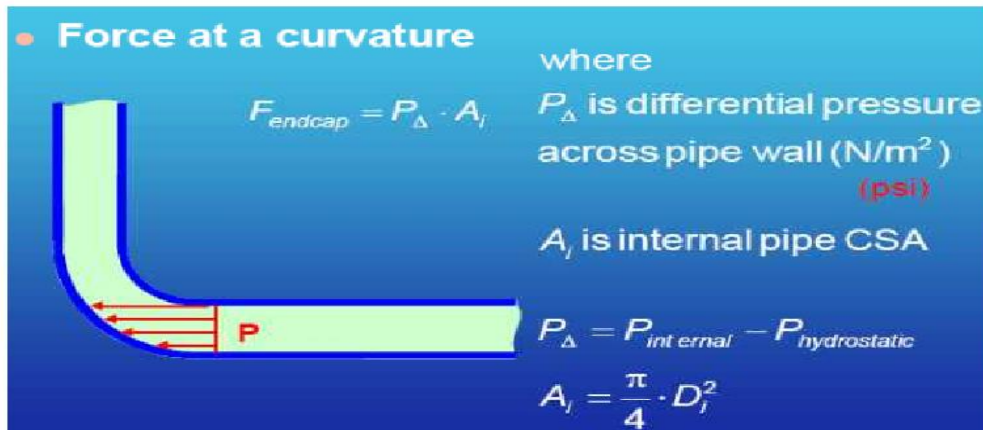

Figure 2-1: End cap force at a curvature (Jee, 2013)

The second effect is the Poisson's effect. The internal pressure induces a hoop stress and the hoop stress induces circumferential expansion of a pipeline and simultaneous axial contraction i.e. the pipe expands in hoop direction, the Poisson's effect results in an axial contraction as shown in the Figure 2-2 below. Resultant stresses and strains for the restrained and unrestrained conditions are given below (Jee, 2013):

For unrestrained pipeline, the corresponding strain and stress due to Poisson's effect are given by:

$$\varepsilon_{Poisson} = -\nu \cdot \varepsilon_{hoop} = -\nu \cdot \frac{\sigma_{hoop}}{E_{steel}} \quad (2-8)$$

$$\sigma_{Poisson} = 0$$

For restrained pipeline:

$$\sigma_{Poisson} = \nu \cdot \sigma_{hoop} \quad (2-9)$$

$$\varepsilon_{poisson} = 0 \quad (2-10)$$

Where: ν : Poisson's ratio

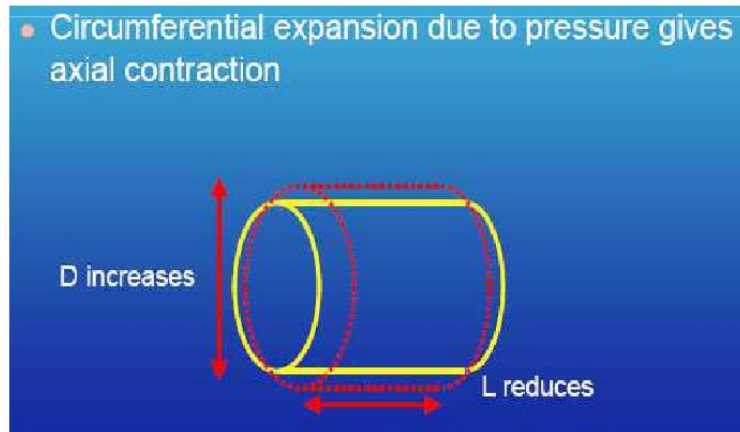

Figure 2-2: Poisson's effect (Jee, 2013)

2.2.3 Combined Effect of Thermal Strain and Pressure

Normally pipeline is subjected to a combined effect of thermal strain, pressure and Poisson effects. And hence the pipeline has to be designed considering these cases. The longitudinal stress due to this effect has two components, a tensile and compressive stress, i.e. tensile stress from pressure and a compressive stress from thermal loads. These stresses and strains are in the axial direction. Induced strain and stress by the combined effect of temperature and pressure for restrained and unrestrained pipeline conditions is given by (Jee, 2013):

For unrestrained case, the longitudinal strain which is directly related to pipeline expansion is given by:

$$\varepsilon_L = \alpha \cdot \Delta T + \frac{\sigma_{hoop}}{2} \cdot \left(\frac{1 - 2\nu}{E_{steel}} \right) \quad (2-11)$$

In the above equation the contribution of the hoop stress and longitudinal stress are incorporated as:

$$\sigma_L = \frac{P \cdot D}{4 \cdot t} = \frac{\sigma_{hoop}}{2} \quad (2-12)$$

$$\sigma_{hoop} = \frac{\Delta P \cdot D}{2 \cdot t}$$

Where: ε_L : Longitudinal strain

σ_L : Longitudinal stress

σ_{hoop} : Hoop stress

ΔP : Pressure difference (internal minus external pressure)

For restrained pipeline condition:

$$\varepsilon_L = 0 \quad (2-13)$$

The above condition yields longitudinal stress as given below

$$\sigma_L = -\alpha \cdot E_{steel} \cdot \Delta T + \nu \cdot \sigma_{hoop} \quad (2-14)$$

2.3 Restraining Force

2.3.1 General

The force required to fully restrain the pipe is as result of the thermal stress, the end cap force and the Poisson's stress is known as the restraining force. As mentioned previously the thermal expansion of the pipe material results from increase in temperature and pressure has two effects that affect the pipeline expansion. One is the end cap force that acts at the points of curvature and results in pipeline expansion. The other is Poisson's effect that is a result of internal pressure in the pipeline and results in contraction of the pipeline.

The restraining force is a compressive force and it is given as (DNV, 2013):

Compressive force= (Thermal force) + (End cap force)-(Force from Poisson's effect)

$$F_{compressive} = E_{steel} \cdot A_s \cdot \alpha \cdot \Delta T + \frac{P \cdot \Pi \cdot D^2}{4} - \nu \cdot \frac{P \cdot D}{2 \cdot t} \cdot A_s \quad (2-15)$$

And, $A_{steel} = \Pi \cdot D \cdot t$

$$F_{compressive} = \Pi \cdot D \cdot t \cdot E_{steel} \cdot \alpha \cdot \Delta T + \frac{P \cdot \Pi \cdot D^2}{4} (1 - 2\nu) \quad (2-16)$$

2.3.2 End Expansion and Build-up of Effective Axial Force

The cumulative axial restrain due to friction resistance counteracts pipeline end expansion. The level of the effective axial force which will develop over the length of pipeline depends on the seabed condition. This effective axial force due to friction build-up until it reaches the

point where the frictional force becomes equal in magnitude but opposite in direction to the anchor force is termed as soil anchor point. The pipe section beyond the soil anchor point is fully constrained since the resultant axial compressive force is totally balanced by the effective axial force due to friction.

At the soil anchor point the frictional force equals anchor force and is given as follows (Palmer & Ling, 1981):

$$F_{friction} \cdot Z = F_{compressive} = E \cdot A_s \cdot \alpha \cdot \Delta T + \frac{P \cdot \pi \cdot D^2}{4} - \nu \cdot \frac{P \cdot D}{2 \cdot t} A_s \quad (2-17)$$

$$F_{friction} \cdot Z = \pi \cdot D \cdot t \cdot E \cdot \alpha \cdot A_s \cdot \Delta T + \frac{P \cdot \pi \cdot D^2}{4} - \nu \cdot \frac{P \cdot D}{2 \cdot t} \cdot A_s$$

For uniform temperature, rearranging of equations gives the active length from free end to soil anchor as:

$$Z = \frac{P \cdot \pi \cdot D^2}{4 \cdot F_{friction}} \left[\frac{4 \cdot t \cdot \alpha \cdot E \cdot \Delta T}{P \cdot D} + (1 - 2 \cdot \nu) \right] \quad (2-18)$$

But for the temperature varying along the pipeline length, the active length from free end to soil anchor is given as (Palmer & Ling, 1981):

$$Z = \frac{P \cdot \pi \cdot D^2}{4 \cdot F_{friction}} \left[\frac{4 \cdot t \cdot \alpha \cdot E \cdot \Delta T}{P \cdot D} \cdot \exp\left(-\frac{z}{\lambda}\right) + (1 - 2 \cdot \nu) \right] \quad (2-19)$$

Here the solution for the anchor length has to be determined iteratively.

And:

$$F_{friction} = \mu_{axial} \cdot W_{sub}. \quad (2-20)$$

Where:

$F_{friction}$: Friction force due soil pipe interaction

z : Length to soil anchor point

μ_{axial} : Axial/longitudinal friction coefficient

W_{sub} : Submerged weight of pipeline

λ : Decay length

E : Young's Modulus

Once the active length free end to anchor point is determined, pipeline expansion is calculated.

Subsea pipelines are also constrained by subsea facilities such as subsea templates which act as anchorage point from longitudinal expansion.

Normally the effective axial force due to soil friction is zero at the free ends of the pipeline and gradually increases until it reaches a point where the frictional restraint is sufficient to counterbalance any expansion, and the axial strain in the pipeline will be zero.

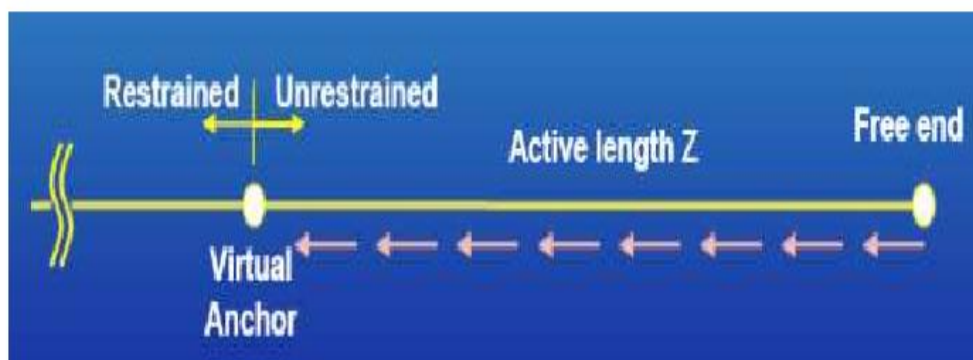

Figure 2-3: Development of virtual anchorage (Jee, 2013)

Figure 2-3 shows the virtual anchor which is developed when the expansion force is equal to the frictional force.

Longitudinal displacement of pipeline depends on the constraints at both ends. For partial constrained or constrained at only one end of the pipeline, longitudinal displacement is possible enabling the pipeline to expand freely. However, if both ends are full constrained, longitudinal displacement will not be possible resulting in the development of compressive forces at both anchor ends. It is this compressive force which can result in the buckling of the pipe.

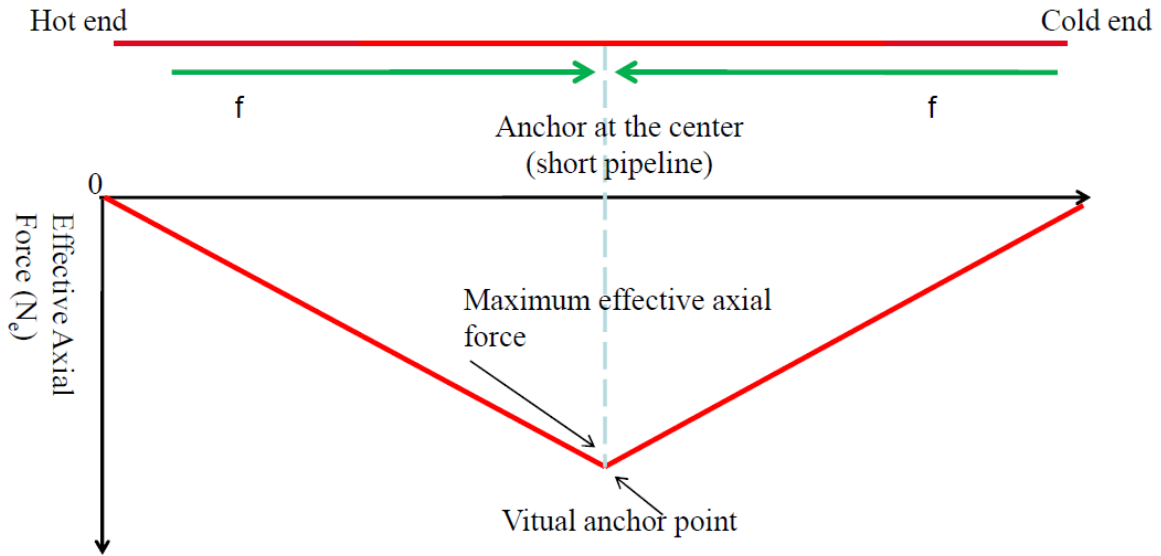

Figure 2-4: Effective axial force in a short pipeline (Palmer & Ling, 1981; Karunakaran, 2013)

A virtual anchor point is said to occur when there is enough effective frictional force due to seabed condition to resist the axial compressive force. A pipeline is considered to be a short pipeline when the pipeline does not have enough length to mobilize the friction force to restrain the axial expansion due to the operating temperature and pressure. In this case the virtual anchor point is at the center of the pipeline as shown in Figure 2-4.

Normally during design process, pipelines are considered to be long pipeline when the pipeline has enough length to develop and mobilize the available friction force. In such cases, there will be two anchor points towards both hot and cold ends. The following Figure 2-5 below shows the development of the anchor points in a long subsea pipelines.

The total expansion U is related to longitudinal strain (Palmer & Ling, 1981):

$$\varepsilon = \frac{du}{dx} \tag{2-21}$$

And the total expansion is found by integrating strain over length z

$$U = \int_0^z \varepsilon(x)dx, \tag{2-22}$$

Rearranging and substituting z , i.e. anchor length, the total expansion can be evaluated as:

$$U = \frac{\pi \cdot D \cdot E \cdot t}{2 \cdot F_{friction}} \cdot \left[\alpha \cdot \Delta T + \frac{P}{E} \cdot \frac{D}{4 \cdot t} (1 - 2\nu) \right]^2 \quad (2-23)$$

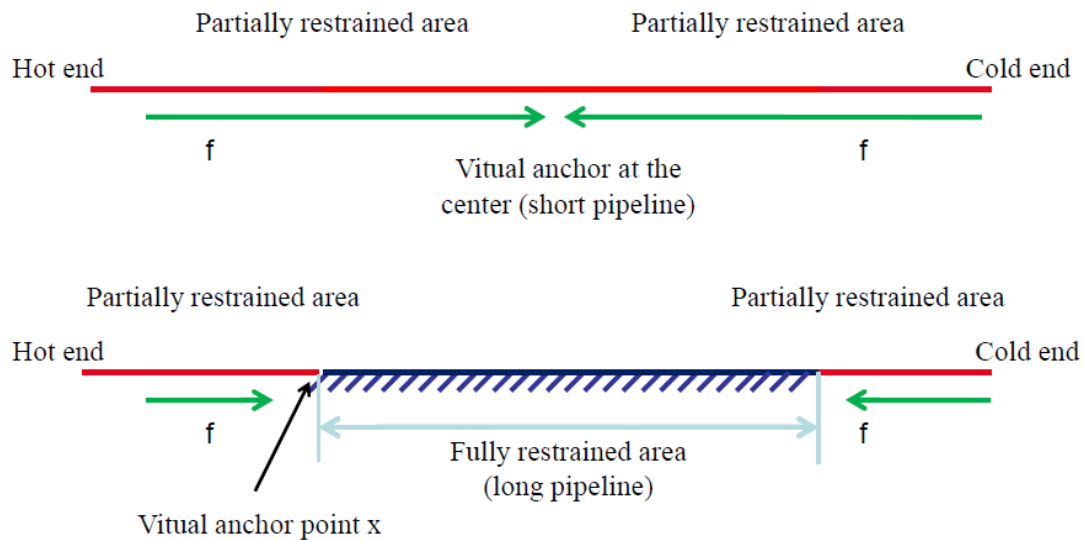

Figure 2-5: Effective axial force versus pipeline length for long pipeline (Palmer & Ling, 1981; Karunakaran, 2013)

2.4 Lateral Buckling

Lateral buckling occurs when exposed pipeline is subjected to axial compressive load beyond the critical buckling capacity, P_{cr} . This occurs for a length of pipeline where full constrain is achieved by the soil-pipe interaction against the thermal expansion of the pipeline.

Once the pipeline is known whether it is a long pipeline or a short pipeline, the axial driving force for lateral buckling is compared with the critical buckling capacity (P_{cr}).

If the axial driving forces i.e. the effective axial force is more than the critical buckling capacity, lateral buckling is predicted to occur.



Figure 2-6: Typical Lateral Buckling Configuration (Einsfeld & Murray, 1984)

2.4.1 Lateral Buckling Modes

Experimental work performed by Hobbs has found that pipeline can buckle into number of alternative post buckled shapes. Each mode requires a different minimum axial force for the onset of lateral buckling.

All the buckling modes resemble sinusoidal curve of varying wave lengths. The infinity mode with infinity wave lengths can be considered as a combination of the others. The most common lateral buckle modes are presented below in Figure 2-7 (Hobbs, 1984).

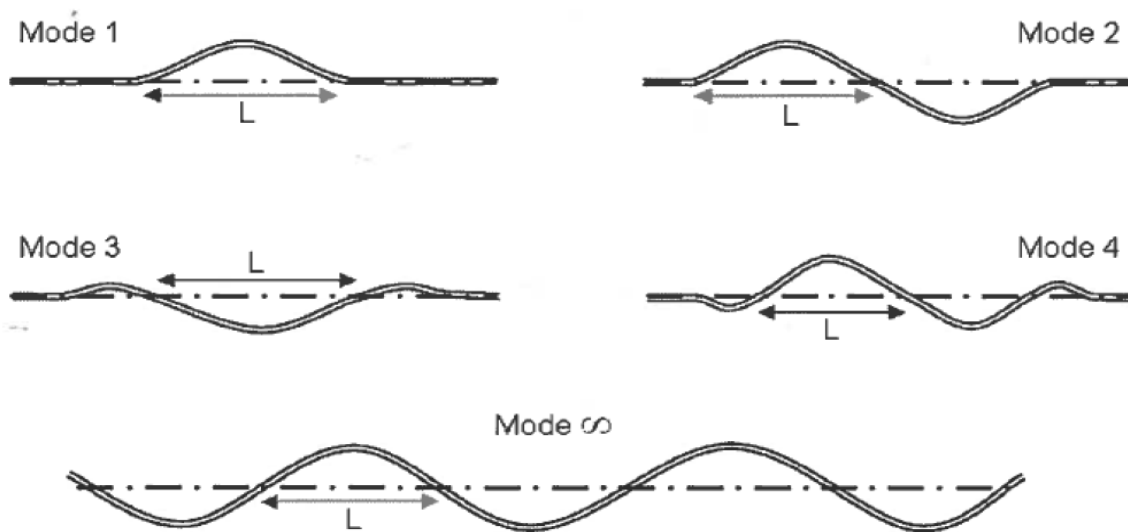

Figure 2-7: Lateral Buckling Modes (Hobbs, 1984)

2.4.2 Hobbs Analytical Method

The analytical method of Hobbs is the most widely used for lateral buckling analyses. The Theory is based on force equilibrium and displacement compatibility after a lateral buckle has formed in a theoretically straight pipe.

The pipeline is treated as a beam-column under axial load with uniform lateral support and the linear differential equation of the buckled portion is solved for the deflected shape. Other assumptions and restrictions are that the pipe material remains elastic and that initial imperfections are not considered.

The prediction of global buckling can serve as a preliminary result upon which FE (finite element) analyses are based. However, they are helpful for prediction of initial out of straightness for using in numerical models after being scaled down since global buckling requires some imperfection in order to initiate.

The relationship between effective axial force at full constraint and the buckle length is given as (Hobbs, 1984):

$$P_o = P_{eff} + k_3 \mu_a WL \left[\sqrt{\left(1 + K_2 * \frac{E * A * \mu_l^2 * W * L^5}{\mu_a (EI)^2} \right)} - 1 \right], \quad (2-24)$$

for modes 1, 2, 3 & 4

$$P_o = P_{eff} + 4.7050 \times 10^{-5} AE \left(\frac{\mu_l W}{EI} \right)^2 L^6, \text{ for infinite mode} \quad (2-25)$$

Where:

P_o = Pre-buckle axial force

E = Modulus of elasticity

μ_l = Coefficient of lateral friction

μ_a = Coefficient of axial friction

A = Steel cross sectional area

I = Second moment of area

L = Buckle length corresponding to P_o

The axial compressive force within the buckle, P is given by:

$$P = K_1 \frac{E * I}{L^2} \quad (2-26)$$

The maximum amplitude of the buckle can then be determined from:

$$y = k_4 \frac{\mu_l \cdot w}{E \cdot I} L^4 \quad (2-27)$$

And the maximum bending moment is given by:

$$M = k_5 \mu_l \cdot W \cdot L^2 \quad (2-28)$$

The five constants k_1, k_2, k_3, k_4 and k_5 are dependent on the mode of buckling and are listed in

Table 2-1 below (Hobbs, 1984).

Table 2-1: Lateral buckling coefficients (Hobbs, 1984)

k_1	k_1	k_2	k_3	k_4	k_5
1	80.76	6.391×10^{-5}	0.500	2.407×10^{-3}	0.06938
2	$4\pi^2$	1.743×10^{-4}	1.000	5.532×10^{-3}	0.1088
3	34.06	1.668×10^{-4}	1.294	1.032×10^{-2}	0.1434
4	28.20	2.144×10^{-4}	1.608	1.047×10^{-2}	0.1483
∞	$4\pi^2$	4.705×10^{-5}	4.705×10^{-5}	4.4495×10^{-3}	0.05066

It should be noted that the above formulations provide a simple and idealized analytical method for determining a pipelines susceptibility to lateral buckling and is based on the following assumptions:

1. The pipeline has sufficient length to develop full axial constraint away from the buckle length, such that axial feed-in can take place over the slip length. The formulation does not adequately model the behavior of pipelines operating within the expansion zone.
2. An idealized straight pipe is assumed and therefore no account is taken for the effect of initial imperfection or buckle initiations.
3. The axial driving force is assumed to be independent of axial stiffness.

2.5 In-service Buckling Design Criteria

The pipelines are designed in accordance with the requirements of DNV-OS-F101 and DNV-RP-F110. DNV-OS-F101 provides equations defining the envelopes of local buckling limits for load controlled and displacement controlled criteria. For the present work both, the pipe capacity is calculated by using both design criteria. The detailed analytical calculation can be found in the Appendix G.

During design stage for lateral buckling, it is recommended to perform a code check for the local buckling and pipe integrity.

2.5.1 Combined Local Buckling Design Criteria

DNV-OS-F101 defines two local buckling design criteria which are described as follows:

- Load Controlled Condition (LCC condition): the structural response is mainly governed by the imposed loads.
- Displacement Controlled condition (DCC condition): the structural response are mainly governed by imposed geometric displacements.

Under the load controlled condition, the pipeline design shall fulfill the following formulation (DNV, 2013):

$$\left(\gamma_m \cdot \gamma_{SC} \cdot \frac{|M_{Sd}|}{\alpha_C \cdot M_P(t_2)} + \left(\frac{\gamma_{SC} \cdot \gamma_m \cdot S_{Sd}(P_i)}{\alpha_C \cdot S_P(t_2)} \right)^2 \right)^2 + \left(\alpha_P \cdot \frac{P_i - P_e}{\alpha_c \cdot P_b(t_2)} \right)^2 \leq 1 \quad (2-29)$$

$$\text{For } 15 \leq \frac{D}{t_2} \leq 45, \quad P_i > P_e, \quad \frac{|S_{Sd}|}{S_p} < 0,4$$

Where:

M_{Sd} : Design moment.

S_{Sd} : Design effective axial force.

P_i : Internal pressure.

P_e : External pressure.

P_b : Burst pressure.

$$\alpha_c : \text{flow stress parameter, } \alpha_c = \left(\left((1-\beta) + \beta \cdot \frac{f_u}{f_y} \right), 1.20 \right)$$

α_p : Accounts for effects of $\frac{D}{t_2}$ ratio,

The plastic axial force is given as: $S_P = f_y \cdot \Pi \cdot (D-t) \cdot t$

And, the plastic moment capacity $M_P = f_y \cdot \Pi \cdot (D-t)^2 \cdot t$

γ_{SC} = Safety class resistance factor, and it is: $\gamma_{SC} = 1.046$ for safety class LOW,

$\gamma_{SC} = 1.14$ for safety class NORMAL and $\gamma_{SC} = 1.308$ for safety class HIGH

γ_m = Material resistance factor

In case of displacement controlled condition, the pipeline design shall fulfill the following mathematical formulation (DNV, 2013).

$$\varepsilon_{Sd} \leq \varepsilon_{Rd} = \frac{\varepsilon_c(t_2, P_{\min} - P_e)}{\gamma_\varepsilon} \quad (2-30)$$

$$\frac{D}{t_2} \leq 45, P_i \geq P_e$$

$$\left(\frac{\varepsilon_{Sd}}{\varepsilon_c(t_2, 0)} \right)^{0,8} + \frac{P_e - P_{\min}}{P_c(t_2)} \leq 1 \quad (2-31)$$

$$\text{For } \frac{D}{t_2} \leq 45, P_{\min} \geq P_e$$

Where:

ε_{Sd} : Design compressive strain

P_e : External pressure

P_b : Burst pressure

P_i : Internal pressure

P_{\min} : Minimum internal pressure

$$\varepsilon_c(t, P_{\min} - P_e) = 0.78 \cdot \left(\frac{t}{D} - 0.01 \right) \cdot \left(1 + 5.75 \cdot \frac{P_{\min} - P_e}{P_b(t)} \right) \cdot \alpha_h^{-1,5} \cdot \alpha_{gw} \quad (2-32)$$

γ_ε : Strain resistance factor

$$\alpha_h = \left(\frac{R_{t0,5}}{R_m} \right)_{\max}, \text{ stress ratio}$$

α_{gw} : Girth weld factor that accounts for stress concentration of girth weld

2.5.2 Load Condition Factor

DNV-RP-F110 (2007), presents a methodology for calculating the load condition factor (γ_c) for pipelines which buckle in-service, where the bending moment response is determined using FE analyses. The load condition factor is based on the prevailing uncertainty in the bending moment response and defined as follows (DNV, 2007):

$$\gamma_c = \max[0.80, 0.72 \cdot (1 + 2 \cdot CoV(X_F))] \quad (2-33)$$

$$CoV(X_F) = \sqrt{(CoV(X_A))^2 + CoV(X_L)^2 + CoV(X_B)^2 + CoV(X_C)^2} \quad (2-34)$$

Where:

γ_c = Load condition factor

$CoV(X_F)$ = Coefficient of variation in resulting moment in buckle

$CoV(X_A)$ = Coefficient of variation from uncertainty in axial friction

$CoV(X_L)$ = Coefficient of variation from uncertainty in lateral friction

$CoV(X_B)$ = Coefficient of variation from uncertainty in stress-strain curve

$CoV(X_C)$ = Coefficient of variations from uncertainty in trawl load

2.6 Feed-in Zone

A buckle region as shown in the Figure 2-8 below consists of the buckle and two slipping region flank on both sides. Once the buckle is formed, the compressive force in the buckle drops and some section of pipe in slip region will feed-in into the buckled section until friction force develops to restrain it. The length of the feed-in zone depends on the available frictional resistance which opposes the feed-in as the pipeline expands.

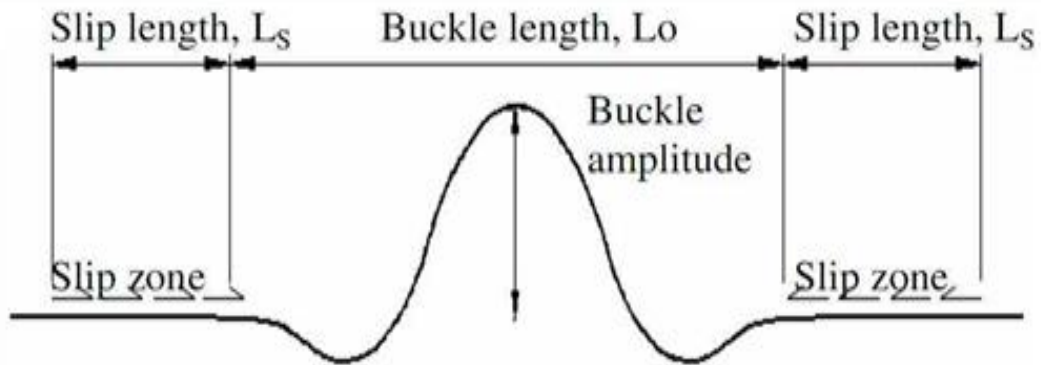

Figure 2-8: Buckle Region (Kien, et al., u.d.)

The formation of a buckle therefore involves the movement of pipe into the buckle from the straight pipeline sections on either side of the buckle, and leads to a modification of the axial force within the pipeline. The axial feed-in movement for a single, isolated buckle in an infinitely long pipeline is illustrated below in in the Figure 2-9 below.

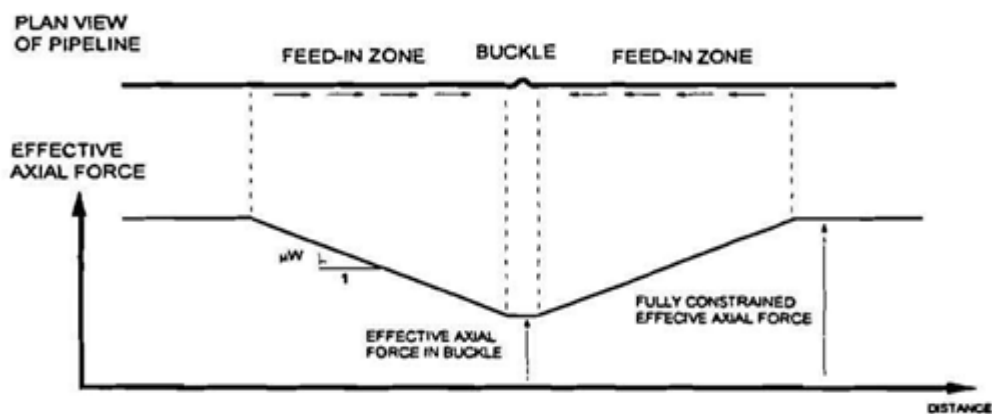

Figure 2-9: Feed-in to a single buckle in an infinite pipeline (Kaye & Plamer, 1996)

2.7 Virtual Anchor Spacing

Once the occurrence of buckling is known, the next step is to estimate the virtual anchor spacing (VAS). It is the distance between two anchor points. The VAS is a key parameter in the lateral buckling design process where it corresponds to the distance which contributes feed-in into certain buckle. If the buckle spacing is close (small VAS) there is less axial feed-in to the buckle, which reduces lateral deflection and load in the buckle. The aim of the design method is for a large number of buckles to form at regular intervals along the flow line. This produces a solution in which the thermal strain is shared between several sites, leading to manageable strains within each buckle.

It is usually recommended minimum of 2km or half of pipeline length in concept design phases.

Lateral buckling leads to the formation of short pipeline sections which are buckled within a long pipeline system. The buckled sections take most of the longitudinal forces but the buckled sections act independent of each other.

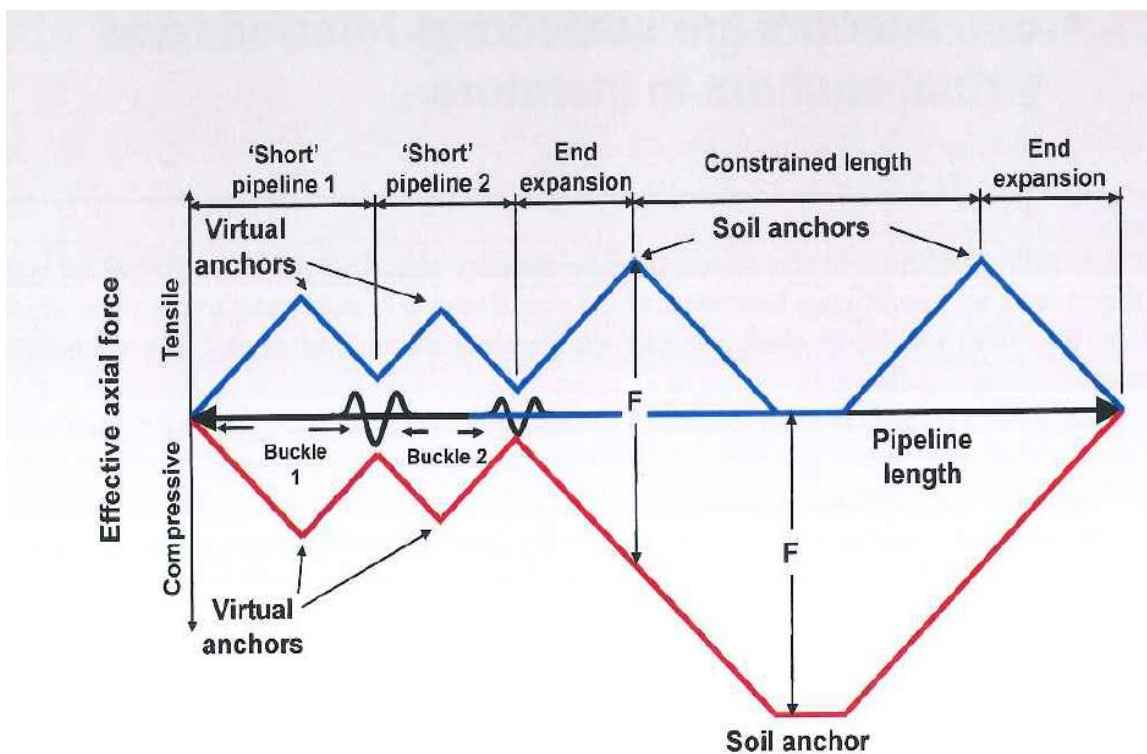

Figure 2-10: Short pipeline Development (Jee, 2013)

Hence if a number of buckles occur, the whole pipeline is considered as a series of independent short pipelines connected to each other. This implies that the out of straightness or imperfections or buckles for that matter make the whole pipeline to be sum of independent short pipelines.

If a pipeline is expected to buckle, the above argument will lead us to design controlled buckling. Controlled buckling design is performed by introduction of virtual anchor spacing (VAS) along the pipelines.

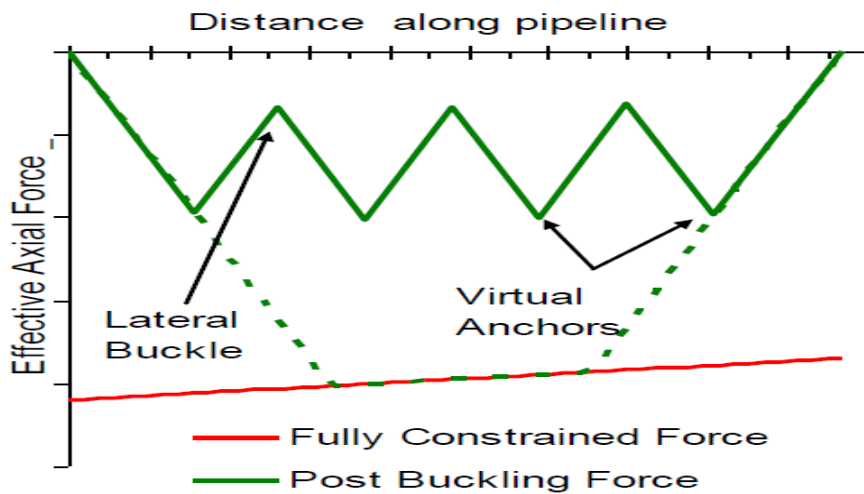

Figure 2-11: Post buckling configuration (Carr, et al., 2011)

2.8 Susceptibility of Lateral Buckling

To assess whether global buckling mitigation measures are required, lateral buckling susceptibility evaluation must be carried out. The occurrence or susceptibility of buckling of a pipeline is evaluated by the magnitude of the driving axial force which is given as the minimum of either the effective axial force within the soil anchor or the maximum pipe-soil frictional resistance when the pipeline is unrestrained.

The maximum axial driving force in a simplified formulation is given as (Jee, 2013):

$$F_{\max} = \min(F, F_{f \max}) \quad (2-35)$$

- And the effective axial force is give as:

$$\begin{aligned}
 N_e &= F_{temp} + F_{end\ cap} + F_{poisson} - F_L \\
 &= E \cdot A_{steel} \cdot \alpha \cdot \Delta T + \Delta P \cdot A_i \cdot (1 - 2\nu) - F_L
 \end{aligned}
 \tag{2-36}$$

- The maximum mobilized pipe-soil frictional resistance is:

$$F_{f\ max} = \mu_{A,\ max} \cdot W_{sub} \frac{L}{2} - F_L
 \tag{2-37}$$

Where: F_{max} : Maximum axial driving force

$\mu_{A,\ max}$: Maximum axial soil coefficient of friction

$F_L = H$: Lay tension

L: Length of pipeline

The critical buckling force for a pipeline having out of straightness is the minimum of its frictional resistance and Hobbs critical lateral buckling force.

- The critical buckling force is:

$$F_C = \min(F_{OOS}, F_{Hobbs})
 \tag{2-38}$$

The frictional resistance for a pipeline with out-of-straightness (OOS) is given as:

$$F_{OOS} = \mu_{L\ min} \cdot W_{sub} \cdot R
 \tag{2-39}$$

Where: $\mu_{L,\ min}$ = Minimum lateral soil coefficient of friction

R = Radius of curvature of out of straightness (OOS)

According to DNV-RP-F110, buckles can be initiated by geometrical imperfections and trawl pull-over interaction.

- Hobbs critical lateral buckling force is given in semi empirical formula as in section 2.6. for different modes:

$$P_o = P + k_3 \mu_a WL \left[\sqrt{1 + k_2 \frac{EA \mu_l^2 WL^5}{\mu_a (EI)^2}} - 1 \right]
 \tag{2-40}$$

DNV-RP-F110 (2007) defines three conditions with respect to buckling susceptibility analysis. Also the standard recommends required checks that shall be performed for each respective condition. The three conditions are:

- No buckling: $F_{\max} \leq P_{cr}$
- May be buckling: $F_{\max} \geq P_{cr}$ But $F_{\max} \leq k_{mb} \cdot P_{cr}$
- Buckling: $F_{\max} > k_{mb} \cdot P_{cr}$

Where: k_{mb} :is axial capacity factor based on engineering judgment usually taken as 1.5.

2.9 Sharing of Buckles

Buckling occurs at different sections of a pipeline and introducing imperfections at different sections will make the pipeline to share the expansion at various sections where the imperfections or curvatures are located. One of the biggest challenges in this regard is how to avoid excessive feed-in to an isolated large buckle (DNV, 2007).

Once buckling occurs, enough axial compression force should build up to initiate second buckle. Sharing between the buckles on the imperfections happens if the following formulation is satisfied (DNV, 2007):

$$S_{R,1} + \Delta S \geq S_{G,2} \tag{2-41}$$

Where:

$S_{R,1}$: post buckle effective axial force in the first buckle

ΔS : Axial force build-up between adjacent buckles calculated by lower bound (LB) soil characteristic.

$S_{G,2}$: Axial global buckling capacity force for the second buckle.

$$S_{G,2} = \text{Max}[S_G(R_2^m, f_L^{UB}), S_G(R_2^{UB}, f_L^m)]$$

Where: R_2 : Radius of imperfect at the second buckle.

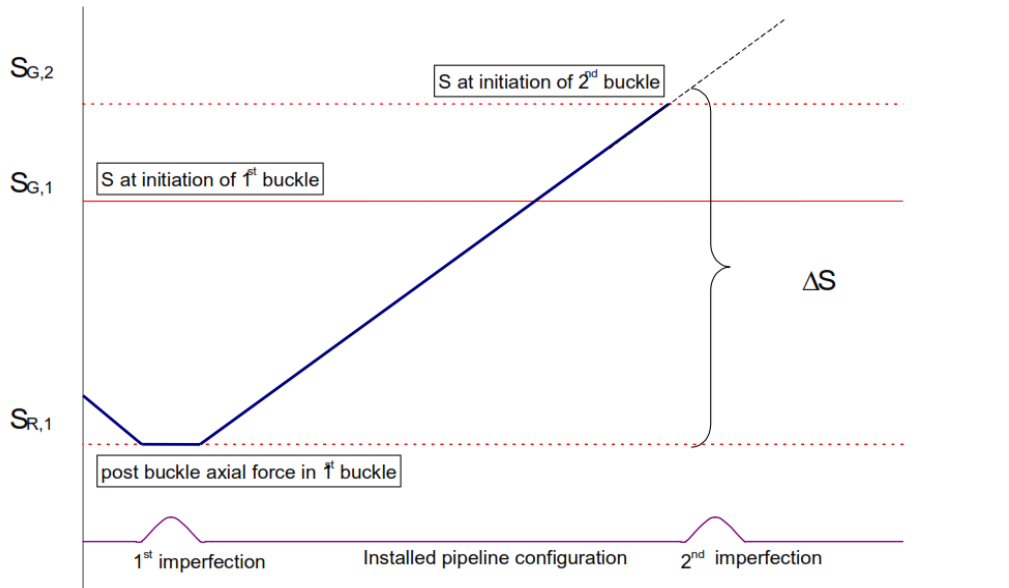

Figure 2-12: Sharing of Buckles, Basic Principle (DNV, 2007)

When axial compressive force which is equivalent or more than the buckling capacity of the imperfection is built-up, buckling occurs at the weakest imperfection section. The weakest imperfection in this regard is the imperfection with large curvature, weak lateral resistance and high temperature. The straight pipeline sections on both sides of the buckled section start to feed-in into the buckled section (DNV, 2007).

Based on DNV-RP-F110 (2007), the maximum section length between adjacent buckles is given as:

$$L = \frac{2}{\mu_a \cdot W_s} \cdot \left[(S_o - S_{post}) - \sqrt{(S_o - S_{post})^2 - \mu_a \cdot W_s \cdot E \cdot A_s \delta} \right] \quad (2-42)$$

Where: S_o = Effective axial force

S_{post} = Posts buckle effective axial force

μ_a = Coefficient of axial friction

μ_l = Coefficient of lateral friction

W_s = Submerged weight of the pipeline

A_s = Steel area

E = Modulus of elasticity

$L =$ Section length

The wave length between the curvatures should be greater than the anchoring length to initiate buckling at the second or adjacent imperfection. The anchor length is a function of initial buckling force and frictional resistance. To initiate buckling on the adjacent imperfection or curve, the axial compressive force greater than the buckling capacity of the adjacent imperfection must be built up. The built-up axial compressive force might not be enough due to short length in between the imperfections i.e., low axial soil resistance, then the next buckle will not be initiated and hence localization occurs. Localization is controlled by sharing the expansion between different buckles (DNV, 2007).

Rock dumping increase the axial restraint and hence it can be used in combination with predesigned imperfection for triggering and controlling buckling (DNV, 2007).

3. PIPELINE INSTALLATION METHODS

3.1 Introduction

Pipeline installation is one of the important stages of offshore field development. There are several ways of installing subsea pipelines, but the most commonly used pipeline installation methods are:

- S-lay
- J-lay
- Reeling
- Towing of pipelines

Each method has its own advantages and disadvantages. The following sections will discuss each method briefly.

3.2 S-lay

It is one of the oldest and commonly used methods of pipeline installation. It takes its name from the shape of the suspended pipe, which lays in a gentle ‘S’ from the stinger to the seabed. The crucial feature of the S-lay method is that the pipe must be tensioned to hold its shape.

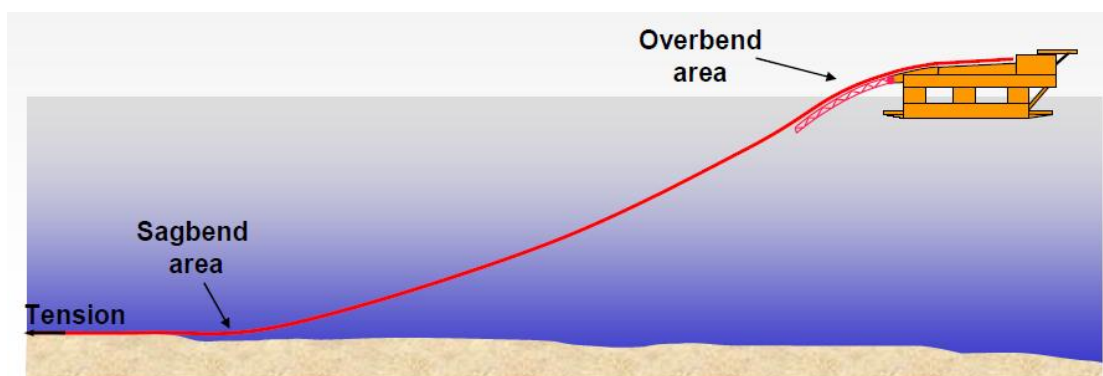

Figure 3-1: Typical S-lay pipe laying (Jee, 2006)

The main procedures of the S-lay method of pipeline installation described as follows (Jee, 2006):

- Initiation: This is the first stage where pipeline must be lowered to the seabed. It shall be done a controlled tension. Then it will be fixed to the sea bed using either of a pile or an anchor. A cable is then linked from the point of fixity to a start-up head on the

pipeline. The pipeline will be lowered to the seabed by a vessel while keeping the tension in the cable so that the correct tension in the pipeline will be maintained.

- Loading and storage: This is a second stage where continuous pipe supply from shore as the pipe lay continues. The loading can be done by a crane onto the lay vessel.
- End preparation: This is the final preparation work before welding. Defects and pipe ends are machined to get the acceptable and required level.
- Double-jointing: This is done to increase welding efficiency.
- The firing line: This station consists of pipe welding, inspection and field joint coating. At the firing line, single or double joints are brought in line with the main pipeline axis and then welded onto the end.
- Tensioning: After passing through a number of welding stations and inspection phases, the pipeline passes through tensioners before leaving the vessel. The tensioners maintain the required tension to keep the pipe in to the predetermined and acceptable curve so that unacceptable bending can be avoided.
- Laydown: This is the final stage where after the pipeline has been completely laid, the end of the pipe lowered to the sea bed. The pipe has to be tensioned while this procedure is taking place.

From the Figure 3-1 above, it can be observed that the pipeline bends twice during the installation using the S-lay method. The upper part of the curved section is normally called as the over bend area and the lower part of the curved section is called the sag bend area as it has been shown above in Figure 3-1.

The capacity of the tension depends on the maximum operational water depths and the submerged weight of the pipeline. It also depends on the allowable radius of curvature at both curved sections, i.e. at the over bend and sag bend area and the departure angle (Bai & Bai, 2005).

The average pipe lay speed of up to 4.5km per day can be achieved by using the S-lay method. The pipe lay rate actually depends on many factors such as pipe size, welding conditions (Braestrup, 2005).

Figure 3-2 below shows the S-lay configuration along with pipeline loading.

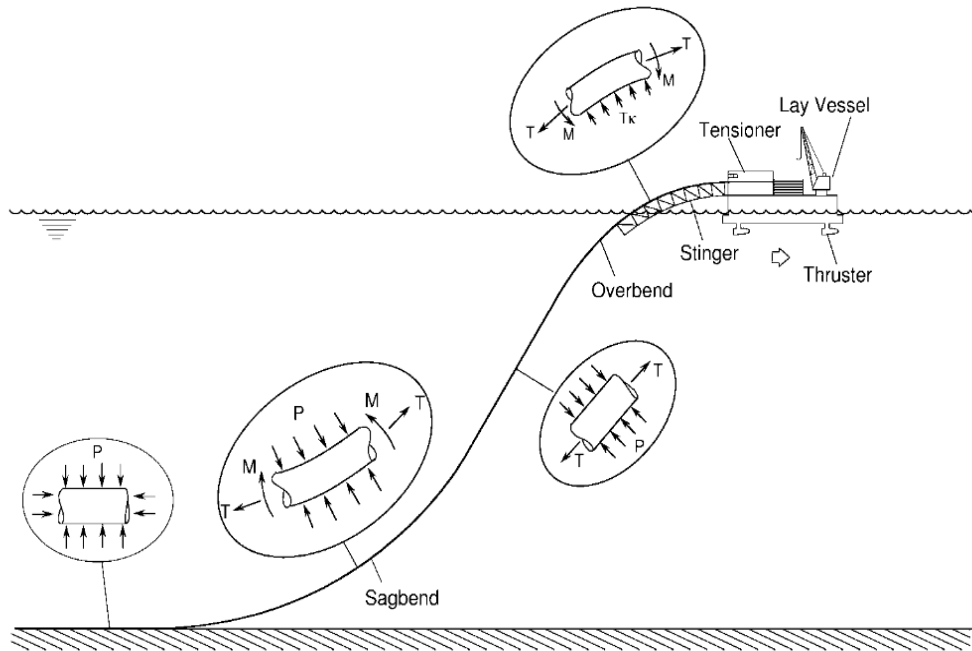

Figure 3-2: Schematic representation of S-lay pipeline installation and pipeline loading (Kyriakides & Corona, 2007)

Some of the advantages of using this method are:

- This method of pipeline installation has got no limitation to pipeline diameter and length.
- It has got more pipe lay speed than the J-lay method.
- It is very versatile that it can be used in a very shallow water depth. This can be achieved by adjusting the stinger angle.
- Better welding performance can be achieved through the non-destructive testing (NDT) as there exists a long fire line.
- Once barge is mobilized, it can operate efficiently with minimum support from shore.

Some of the disadvantages of S-lay pipeline laying methods are:

- Limited capability to weather wane under rough weather.
- Its limitation of using in very deep water as there is a limitation of tension capacity.
- The pipeline and the stinger are exposed to larger hydro dynamic loads as it enters the water.

3.3 J-lay

J-lay takes its name from the shape of the suspended pipe, which forms a 'J' going from the surface of the vessel to the seabed. S-lay shall not be practical at larger water depths. The weight of the suspended pipeline will be excessive to handle it.

As the name indicates, the pipe in J-lay method enters the water in a vertical or nearly vertical position as it has shown in Figure 3-3 below. This helps to eliminate the firing line where the girth welding and field joint coating can be taken place in one or maximum at two stations only.

Tensioning of the pipe to hold the pipeline in a controlled and required curve is provided by a vessel as in the case of the S-lay method. But, due to the reduction in the pipeline length which is suspended along the water depth, the required amount of tension is reduced using J-lay method of pipeline installation (Kyriakides & Corona, 2007).

Furthermore, using the J-lay method of pipeline installation allows a better vessel control as there is only a short length of the suspended pipeline length is exposed to hydrodynamic loads and at the same time the free span gets reduced due to the low tension on the pipeline on the seabed (Kyriakides & Corona, 2007).

In J-lay method of installation, there is no horizontal stinger as in the S-lay method and hence there is no need for the pipe to enter the water at the stern of the vessel (Braestrup, 2005).

Figure 3-3 shows a schematic representation of J-lay pipeline installation.

Some of the advantages of this method are (Palmer & King, 2004):

- The required tension to hold the suspended pipeline is less in this method than the tension in S-lay method because of the steep ramp angle.
- No need of a stinger in this method.
- Splash zone loads are lesser here than the loads from S-lay method.
- The free span gets smaller as the tension is reduced.
- It is easier to position the barge as the touch down point is closer to the barge compared to the S-lay method and this makes it is better suited to lay the pipeline in congested area.
- This method allows the barge to weather vane around the pipe in rough weather.

Some of the disadvantages of the J-lay method are (Palmer & King, 2004):

- Because of the steep ramp angle which can accommodate only fewer simultaneous operations of pipeline installation, i.e. welding, tensioning and other pipeline installation preparation works.
- The added weight of the ramp high up on the barge can affect the vessel stability in harsh environment.
- It is not feasible to use this method for shallow waters as the ramp has to be lowered to a less steep angle.

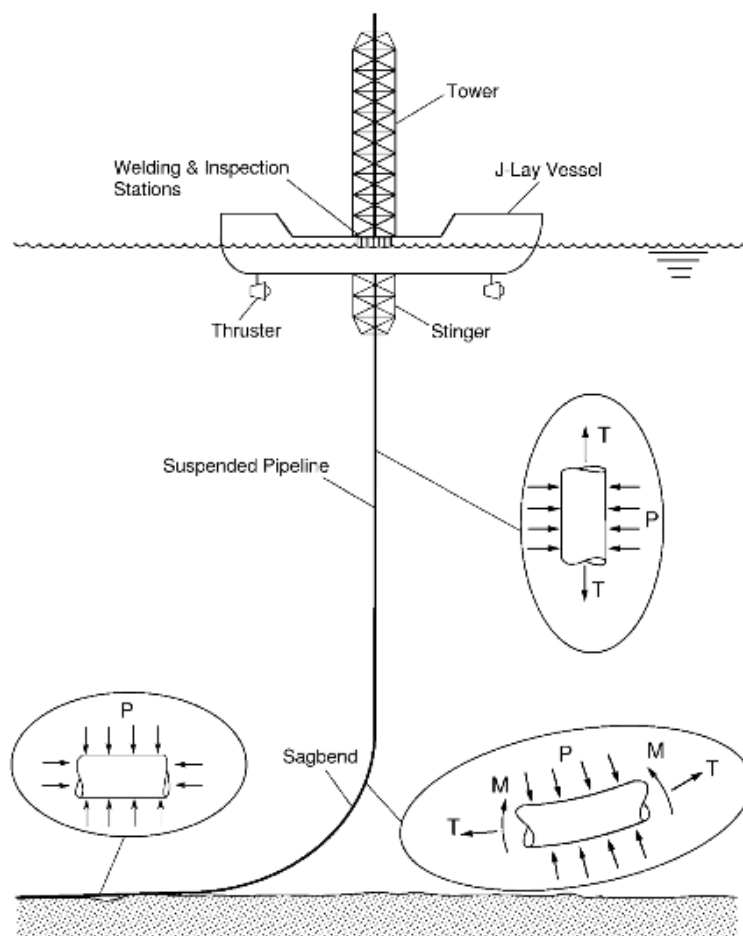

Figure 3-3: Schematic representation of J-lay pipeline installation and pipeline loading (Kyriakides & Corona, 2007)

3.4 Reel-lay

Reel-lay is a method where a rigid or flexible pipe is reeled off from a drum, passing through tensioners and finally laid over a ramp to the seabed. Normally this method of installation considered as the most versatile method of pipeline installation. It is also considered as the most cost efficient method of pipeline installation as majority of the work is done onshore. Adopting this method reduces offshore installation time as the majority of the pipe joints can be welded, tested and coated at an onshore facility base continuously (Kyriakides & Corona, 2007).

In this method of pipeline installation, the pipeline will under go to plastic deformation of the material as the continuous spooling and unspooling induces bending curvature in the pipeline. For example, the Apache reel with 8.23m radius as shown below in Figure 3-4 induces a strain of 1.93% with a 12” pipeline. Similarly, it induces 2.41% strain for a 16” pipeline (Kyriakides & Corona, 2007).

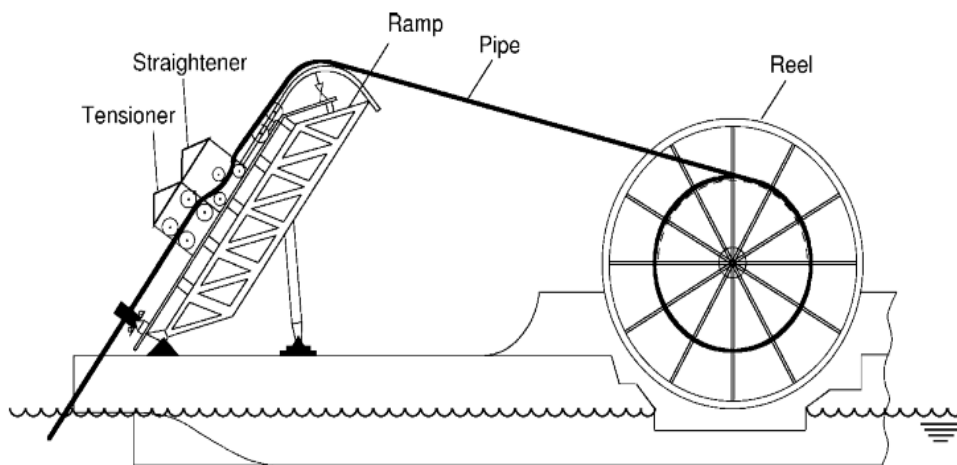

Figure 3-4: Technip’s Apache schematic representation of reeling method (Kyriakides & Corona, 2007)

The main components of the reel-lay method of pipeline installation are (Jee, 2006):

- **Reel:** The pipe spooled on the reel and ready for laying.
- **Stern Ramp:** Tensioning and straightener are suited here. The ramp can be adjusted vertically.
- **Straightener:** This device straightens the pipe by reverse bending as it comes off the reel and being ready for laying.
- **Tensioner:** This keeps the weight of the pipe-string when it is unspooled.



Figure 3-5: Reel-lay Vessel Subsea7's Seven Navica (Subsea7, 2012)

The advantages of the reeling methods are:

- The reel method reduces labor costs by permitting much of the welding, x-raying, corrosion coating, and testing to be accomplished onshore, where labor costs are generally lower than comparable labor costs offshore.
- The reeled pipeline can be installed in an S-lay method or J-lay method depending on the design of the reel vessel and the depth of water.
- This method can be used for pipeline bundles.
- Reeled pipelines can be installed up to several times faster than conventional pipelay. The greater speed allows pipelines to be laid during a short weather window.

Some of the disadvantages of this method are:

- It has got a pipe size limitation; it can be used on up to only 18 inches in diameter.
- It induces plastic strain during spooling and unspooling.
- There is also a limitation in pipeline length that can be reeled onto a single reel. If the pipeline has a larger diameter, the length of the pipeline to be reeled on will be lesser.

3.5 Towing Method

In this method, the pipeline is constructed at an onshore site and is then towed to the installation site by towing boats. Welding, inspection and testing are done at the onshore site before the installation and hence it reduces installation time and cost (Kyriakides & Corona, 2007).

Towing is typically beneficial for smaller lines need to be laid and can be bundled inside a larger pipe. In towing method, there are 4 different ways of towing a pipeline. These are (Kyriakides & Corona, 2007):

- Surface tow
- Controlled depth tow (CDT)
- Off-bottom tow
- Bottom tow

Figure 3-6 through Figure 3-9 illustrate the above mentioned towing methods. These methods have their own advantages and disadvantages (Jee, 2006). The surface tow method is the simplest of all the other methods. But it has got high risk of fatigue and it requires calm conditions.

The advantage of the controlled depth tow (CDT) is that the bundles can be towed below the splash zone, i.e. the wave affected area, but it requires accurate control of tension in bundle and it needs large tugs for control.

Adopting the off-bottom tow method enables to install bundles in a curve, but it needs accurate seabed survey.

The last method of pipeline installation under this category is bottom tow method where there is a possibility of having minimum bundle weight. Similar to the off-bottom tow, this method also requires accurate seabed survey and it needs high safety at crossings.

PIPELINE INSTALLATION METHODS

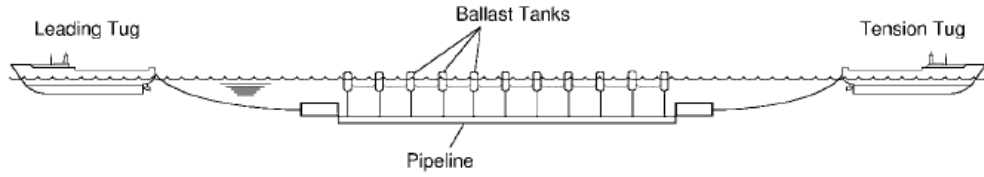

Figure 3-6: Schematic of surface tow method (Kyriakides & Corona, 2007)

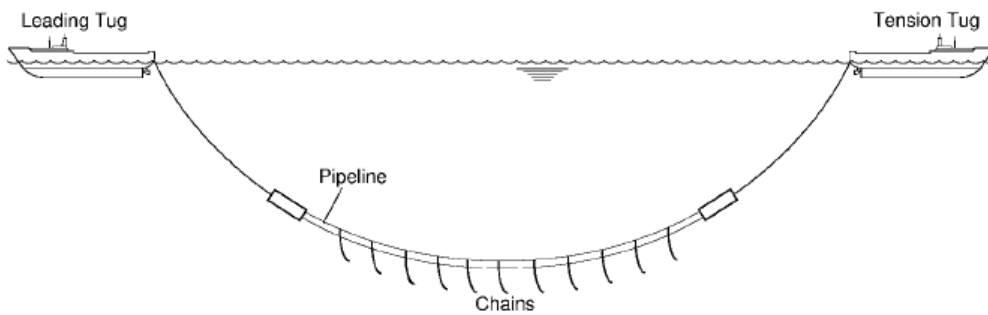

Figure 3-7: Schematic of controlled depth tow method (Kyriakides & Corona, 2007)

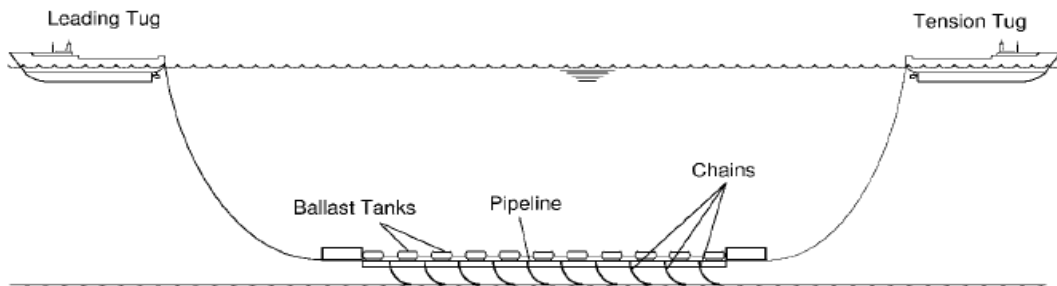

Figure 3-8: Schematic of off-bottom tow method (Kyriakides & Corona, 2007)

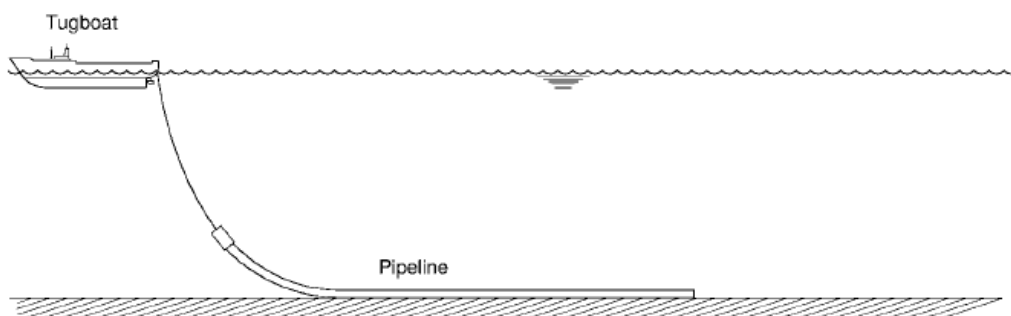

Figure 3-9: Schematic of bottom tow installation method (Kyriakides & Corona, 2007)

4. ASSESSMENT OF PULL-OVER LOADS AND DURATIONS

4.1 Pullover Loads for Trawl Board

The pull-over loads for trawl board are calculated by using the following empirical formulae given in DNV-RP-F111 (2010).

The maximum lateral pull-over load of a Trawl board, F_p is given by:

$$F_p = C_F \cdot V \cdot (m_t \cdot k_w)^{0.5} \quad (4-1)$$

Where:

$$k_w = \text{Warp line stiffness} = \frac{3.5 \cdot 10^7}{L_w} [N / m]$$

V = Trawling velocity

m_t = Trawl board steel mass

L_w = Length of the warp line (typically 2.5 to 3.5 times the water depth)

The coefficient C_F , for Polyvalent and rectangular boards is calculated as follows:

$$C_F = 8 \cdot \left(1 - e^{-0.8 \cdot \bar{H}} \right)$$

And the dimensionless height \bar{H} , is given by:

$$\bar{H} = \frac{H_{sp} + D_o / 2 + 0.2}{B}$$

Where:

H_{sp} = Span height

D_o = Pipe outer diameter

B = Half-height of the trawl board

For Trawl boards the maximum vertical force acting in the downward direction can be estimated as (DNV, 2010):

$$F_z = F_p \cdot \left(0.2 + 0.8 \cdot e^{-2.5 \cdot \bar{H}} \right) \quad (4-2)$$

Where:

e = Mathematical constant ($e \approx 2.718$)

4.2 Pull-over Loads from Clump Weight

The pull-over load for Clump weight is calculated using the following empirical equations given in DNV-RP- F111. The maximum lateral pull-over load of a clump weight, F_p is given by (DNV, 2010):

$$F_p = 3.9 \cdot m_t \cdot g \cdot \left(1 - e^{-1.8h'} \right) \cdot \left(\frac{D_o}{L_{clump}} \right)^{-0.065} \quad (4-3)$$

Where:

h' is a dimensionless moment arm

$$h' = \frac{H_{sp} + D_o / 2}{L_{clump}}$$

D_o = Pipe outer diameter including coating

L_{clump} = Distance from the reaction point to the center of gravity of the clump weight

($L_{clump} = 0.7\text{m}$ for drum diameter of 0.76m)

m_t = Clump weight mass

g = gravitational acceleration

H_{SP} = Free span height

The maximum vertical upward force, F_z , is given by :

$$F_z = 0.3F_P - 0.4m_t g \quad (4-4)$$

And the maximum vertical downward force, F_z , is given by:

$$F_z = 0.1F_P - 1.1m_t g \quad (4-5)$$

Detailed calculations of the pull-over loads and durations can be found in Appendix F of the current thesis.

4.3 Pull-over Loads for Beam Trawls

The maximum horizontal force applied to the pipe, F_p is given by (DNV, 2010):

$$F_P = C_F \cdot V [(m_t + m_a) \cdot k_w]^{1/2} \quad (4-6)$$

Where:

F_p = Total pull-over force

m_t = Steel mass of beam

m_a = Hydrodynamic added mass and mass of entrained water

4.4 Trawl Pull-over Duration

4.4.1 Trawl Board Pull-over Duration

The pull-over time, T_p , is the total time where the trawl board is in contact with the pipe and it is given by (DNV, 2010):

$$T_P = 2C_F \sqrt{\frac{m_t}{k_w}} + \frac{\delta_p}{V} \quad (4-7)$$

Where:

δ_p = Displacement of the pipe at the point of interaction which is unknown prior to analysis.

According to DNV-RP-F111 (2010), it is assumed that:

$$\frac{\delta_p}{V} = \frac{2C_F \left(\frac{m_t}{k_w} \right)^{0.5}}{10} \quad (4-8)$$

Figure 4-1 below shows the sketch of force-time history of the horizontal (F_p) and vertical (F_z) forces applied to the pipeline for trawl boards.

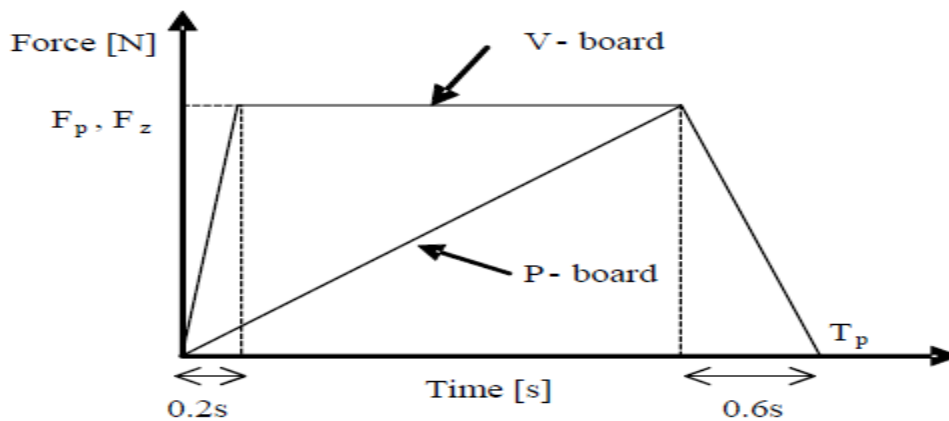

Figure 4-1: Force-time history for Trawl boards pull-over force on pipelines (DNV, 2010)

4.4.2 Clump Weight Pull-over Duration

The pull-over duration of the roller type clump weight is given by (DNV, 2010):

$$T_P = \frac{F_p}{k_w V} + \frac{\delta_p}{V} \quad (4-9)$$

As the pipeline deflection, δ_p , is unknown, according to DNV-RP-111 (2010), it is assumed that:

$$\frac{\delta_p}{V} = 0.1 \left(\frac{F_P}{k_w V} \right)$$

And this implies: $T_P = 1.1 \cdot \frac{F_P}{k_w \cdot V}$

Where:

k_w = Warp line stiffness

V = Clump weight velocity

δ_p = Pipeline deflection

The force-time relation for a clump weight impact is divided into three steps as shown in the Figure 4-2 below.

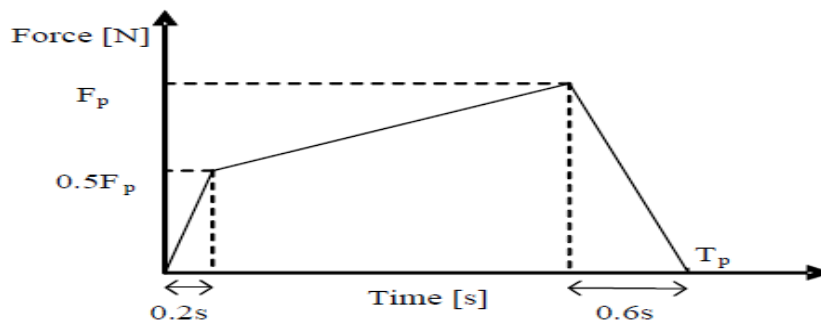

Figure 4-2: Force-time relation for a Clump weight (DNV, 2010)

4.4.3 Beam Trawl Pull Over Duration

The total pull-over time, T_p , beam trawl is given by (DNV, 2010): $T_p = 1.5 \cdot C_F \sqrt{\frac{m_t}{k_w} + \frac{\delta_p}{V}}$

Where:

δ_p = Displacement of the pipe at the point of interaction which is unknown prior to analysis.

According to DNV-RP-F111 (2010), it is assumed that:

$$\frac{\delta_p}{V} = \frac{1.5 \cdot C_F \left(\frac{m_t}{k_w} \right)^{0.5}}{10} \quad (4-11)$$

Figure 4-3 below shows the sketch of force-time history of the horizontal (F_p) and vertical (F_z) forces applied to the pipeline for beam trawls.

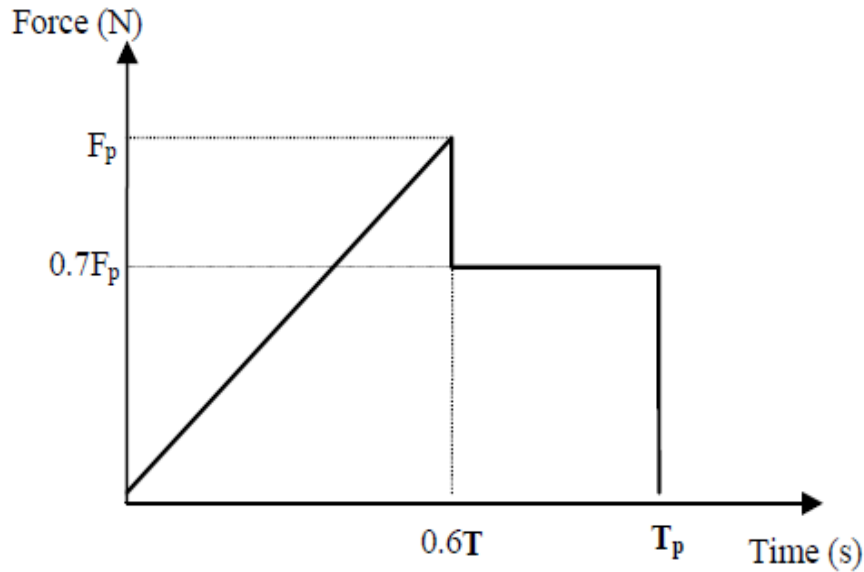

Figure 4-3: Force-time relation for Beam trawl pull-over force on pipeline (DNV, 2010)

4.5 Load Combinations by Trawl Interference

Trawl pull-over may create an OOS large enough to initiate global buckling. In accordance with DNV-RP-110 (2007), buckling due to trawl interference shall be evaluated by a set of trawl pullover loads and pipe-soil resistances by FE analyses. DNV specifies trawl load combinations by defining the lateral soil friction and trawl pull-over load as the soil-trawl matrix shown below in. The matrix implies a maximum of 3 FE analyses with different combinations of trawl load and lateral soil resistance forces.

Table 4-1: Load combinations (DNV, 2007)

f_L^{UB}	-	-	-
f_L^{BE}	-	-	Scenario 3: (F_T^{UB}, f_L^{BE})
f_L^{LB}	-	Scenario 2: (F_T^{BE}, f_L^{LB})	Scenario 1: (F_T^{UB}, f_L^{LB})
	F_T^{LB}	F_T^{BE}	F_T^{UB}

Where: f_L = Lateral soil resistance force displacement curve

F_T = Factored characteristic trawl pull-over load

ASSESSMENT OF PULL-OVER LOADS AND DURATIONS

LB = Lower bound, *BE* = Best estimate, and *UB* = Upper bound

The assessment is based on FE analyses of three scenarios using (F_T^{UB}, f_L^{LB}) denoted as scenario 1, using (F_T^{BE}, f_L^{LB}) denoted as scenario 2, and using (F_T^{UB}, f_L^{BE}) denoted scenario 3 and I performed as follows (DNV, 2007):

- No buckling condition is obtained if global buckling does not occur for the scenario 1
- No buckling condition is obtained if neither of the scenarios 2 and 3 experience global buckling
- May be buckling (SLS/ALS) condition is obtained if either scenario 2 or 3 experience global buckling
- Buckling (ULS) condition is obtained if both scenario 2 and 3 experience global buckling.

Both soil friction and trawl pull over loads are variable effects. To account for any variability in soil properties, DNV-RP-F110 (2007) specifies an approach using a lower bound, an upper bound and a best estimate force displacement curve of lateral resistance, f_L . The lateral resistance curves are generated using the lower and upper bounds and best estimates of all the individual soil properties. The lower and upper bounds are typically defined as the mean \pm 2.0 standard deviations (DNV, 2007).

Variation in trawl load is accounted for by the use of a factored characteristic trawl pull over load, F_T , calculated as per Table 4-2 below. DNV-RP-F110 (2007) defines the trawl pull over loads to be used in design based on the annual trawling frequency per pipeline section, f_T , and the characteristic trawl pull over load, F_p .

Table 4-2: Trawl pull-over loads characteristics (DNV, 2007)

<i>Pull – over Loads</i>	$f_T > 1$	$10^{-4} < f_T < 1$	$f_T < 10^{-4}$
F_T^{UB}	$1.3 F_p$	$1.0 F_p$	NA
F_T^{BE}	$1.0 F_p$	$0.8 F_p$	NA
F_T^{LB}	$0.4 F_p$	$0.3 F_p$	NA

5. METHODOLOGY

5.1 General

In this chapter, the design methodology used in the lateral buckling design of the selected subsea pipeline will be discussed. An initial lateral buckling assessment was performed based on Subsea 7 Design Guideline for lateral buckling in accordance with DNV-OS-F101, DNV-RP-F110, DNV-RP-F111 and SAFEBUCK guideline.

A design concept was developed to allow the pipeline to buckle in a controlled manner at pre-determined locations using the snake lay configuration method. The selected solution considers rock berms to control end expansion and appropriate feed-in at each of the planned buckled sites. The height of the rock was designed to provide adequate restraint to pipeline expansion and resultant feed-in at the buckle locations.

Analytical calculations that include screening check for lateral buckling, Hobbs critical buckling forces and pull-over loads and pull-over durations from trawl interference are carried out using Mathcad 15 and excel spreadsheet. The detailed calculations can be found in Appendixes of the thesis.

5.2 Design Assumptions

- The critical buckling force for a pipeline having out of straightness is the minimum of its frictional resistance and Hobbs critical lateral buckling force.

$$F_C = \min(F_{OOS}, F_{Hobbs})$$

- The entire length of the pipeline rests on the seabed (no spans).
- The cross-sectional properties of the pipeline are constant along the entire length.
- Residual tension is assumed to be zero.
- The submerged weight per unit length of the pipeline is constant along its entire length.
- The feed-in length for each buckle shall be equal to the maximum feed-in length into the buckle that will not cause pipeline failure under all limiting states.
- Hobbs analysis for lateral buckling is based on straight pipeline with no imperfection.
- The effect of the hydrodynamic forces is not considered in the current work.
- The temperature profile is assumed to be exponentially distributed along the pipeline.

- The allowable feed-in capacity of the pipeline shall be calculated in accordance with DNV-RP-F110 (2007).

5.3 Finite Element Analysis

5.3.1 General

The Hobbs analytical solution provides a simple methodology for determining the susceptibility of a pipeline to buckle under in-service conditions. As discussed in previous sections, the Hobbs method doesn't consider any imperfections, and hence detailed finite element (FE) analyses with a non-linear solution are required to account for initial imperfection and post buckling behavior in the pipeline. Furthermore, detailed finite element analyses are required to determine the moments and forces at the buckle and verify compliance with the design code.

The FE analyses were performed using ANSYS mechanical APDL. The FE modeling includes modeling of seabed, pipeline material, pipeline geometry with initial imperfection, and pipe-soil interaction, and further includes defining the temperature profile and boundary conditions.

5.3.2 Finite Element Modelling

This section presents the main features of the FE model. As mentioned previously, the present work considers snake-lay to introduce an out-of-straightness (OOS) for the controlled lateral buckling design of the selected pipeline. Snake-lay configuration of the pipeline is determined based on the allowable feed-in capacity of the buckle initiated by out-of-straightness (OOS). In-order to assess the allowable feed-in capacity of the pipeline, it is required to establish a local FE model and perform analyses. Figure 5-1 below demonstrates the proposed finite element model which is described in the following sub sections.

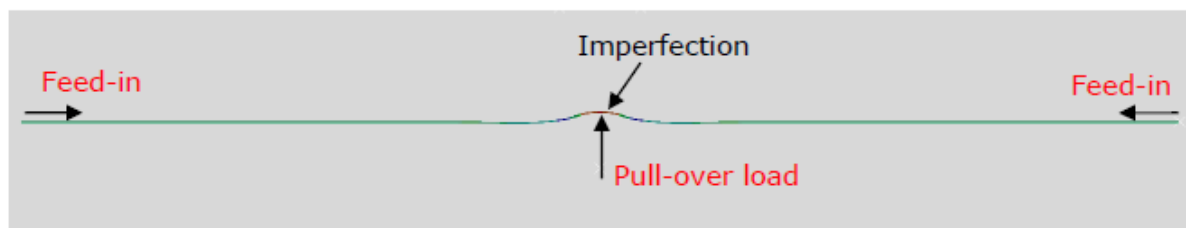

Figure 5-1: Pipeline finite element model

5.3.3 Geometry Modelling

The pipe section of 22" OD is modeled with PIPE288 element available in FE stool, ANSYS. The PIPE288 element is two-node 3-D pipe element as seen in Figure 5-2 and has six degrees of freedom at each node (the translations in the x, y, and z directions and rotations about the x, y, and z directions). The element is well-suited for linear, large rotation, and/or large strain nonlinear applications.

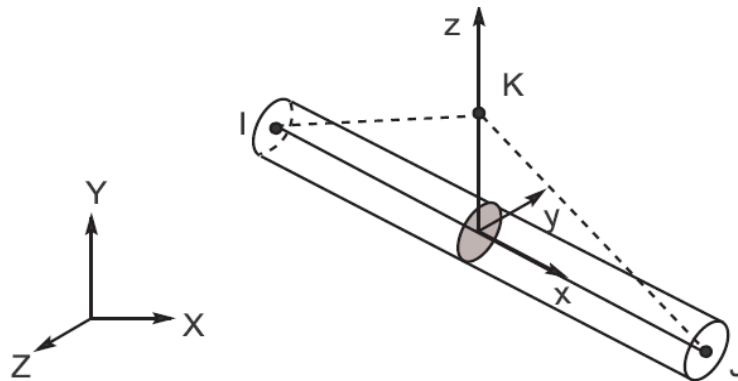

Figure 5-2: PIPE288 geometry (ANSYS, 2009).

a) FE Model for Snake-lay:

FE model of 2km pipe section with given snake (OOS) radius is established for the analyses. The model is meshed with the element size of approximately 1.0xOD (outer diameter). The pipeline model with seabed can be seen in Figure 5-3.

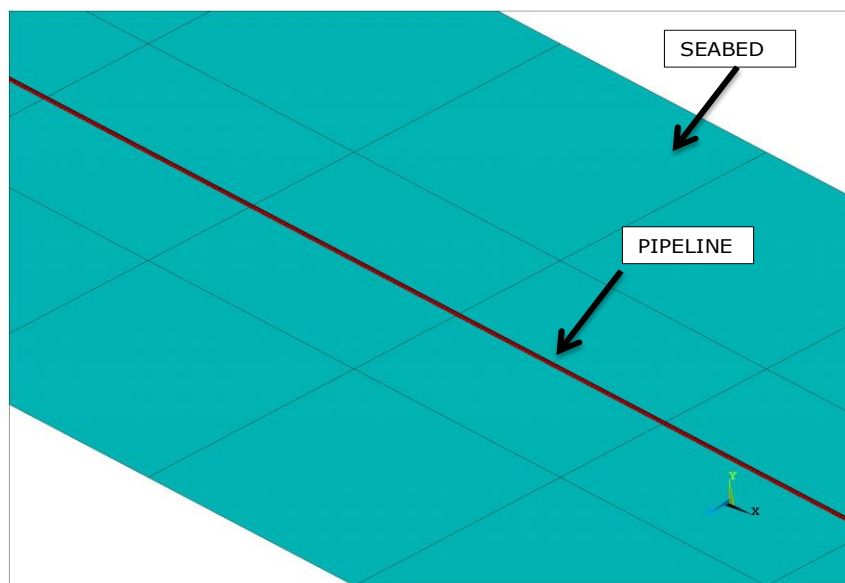

Figure 5-3: Pipeline model (PIPE288) element in ANSYS

b) FE Model for Residual Curvature:

The selected 14” OD pipe section of 1km is used for building the local model for residual curvature method. The PIPE288 element described in the previous section was used to model the pipe section. Also in this case, the model is meshed with the element size of approximately 1.0xOD (outer diameter).

In order to generate the residual curvature shown in Figure 5-4, three cylinders presented in Figure 5-5 have been modelled using the radii based on the dimensions from Figure 5-4. The cylinders have been modelled using the target element named as TARGE170. The Contact between the pipe and cylinders in the FE model was established by defining 3-D node-to-surface contact using the contact element named as CONTA175.

Two small cylinders are fixed and the larger cylinder is pushed until the strain in the pipe reaches to the required residual strain. This results in curvature shown in Figure 5-6. The boundary conditions for the pipe model are such that it is allowed to move longitudinally.

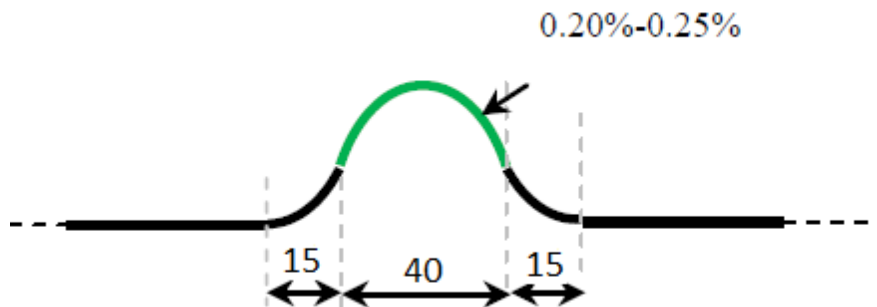

Figure 5-4: Configuration of residual curvature as an initial imperfection

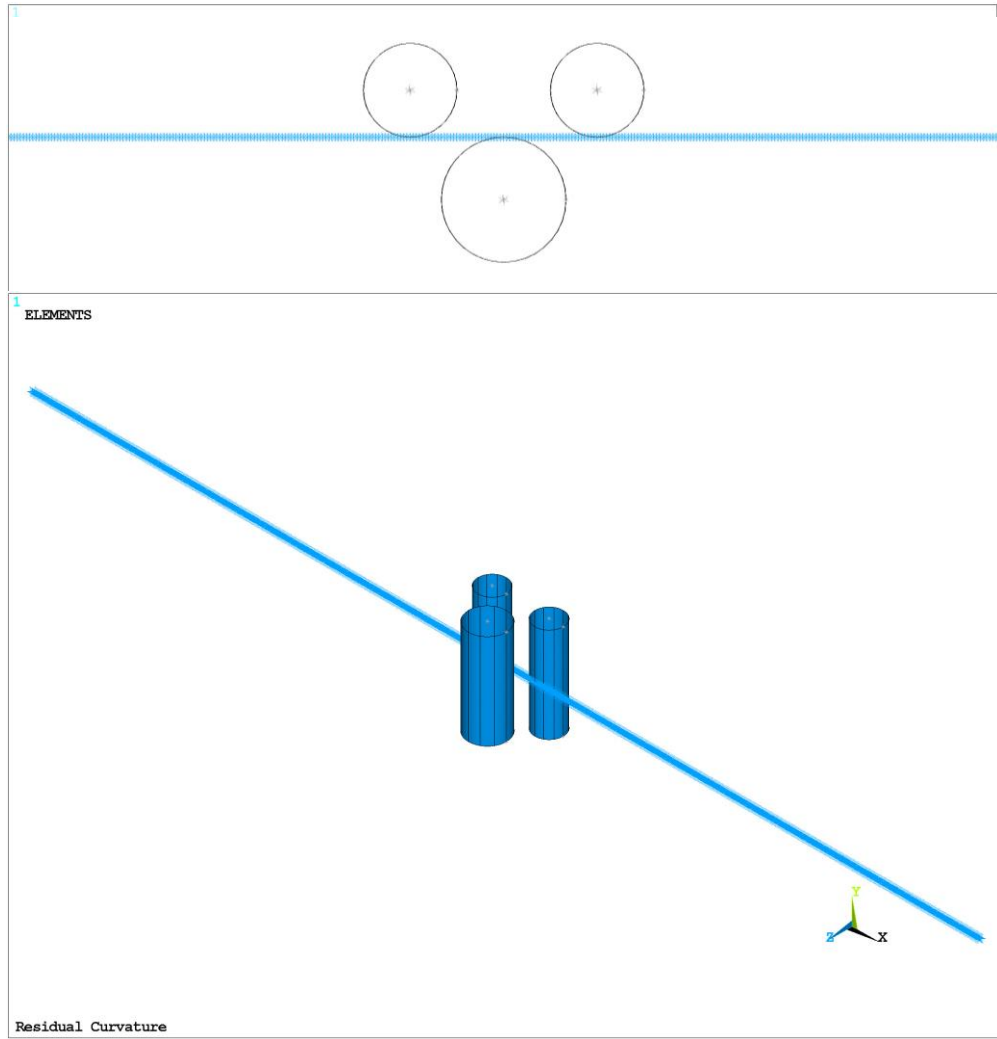

Figure 5-5: FE model to strain the pipe for residual curvature

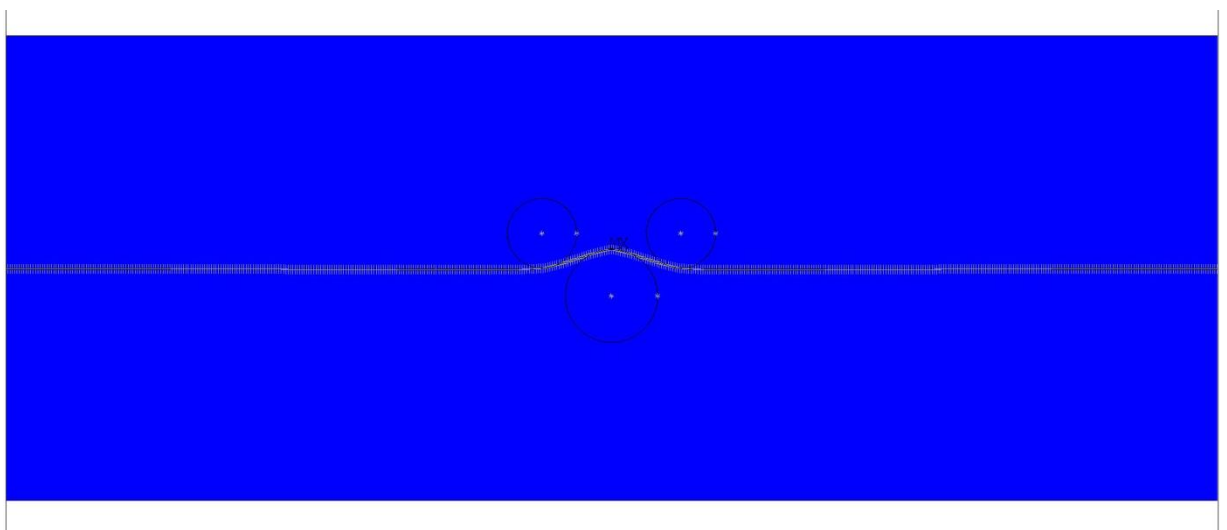

Figure 5-6: FE Model after pipe strained for residual curvature

5.3.4 Material Modelling

Material characteristics of the pipeline are modelled using the nonlinear isotropic hardening model. The elastic-plastic behavior of the material has been captured through the strain hardening model based on a Ramberg-Osgood defined below (Kyriakides & Corona, 2007):

$$\varepsilon = \frac{\sigma}{E} + \alpha \frac{\sigma_0}{E} \left(\frac{\sigma}{\sigma_0} \right)^n \quad (5-1)$$

Where:

ε = uniaxial strain

σ = associated stress

E = elastic modulus

σ_0 = reference stress

σ & n = dimensionless fitting parameters.

Figure 5-7 presents the stress-strain characteristics of the pipeline material defined in FE analyses.

Figure 5-8 presents the stress-strain characteristics of the pipeline material for the residual curvature method.

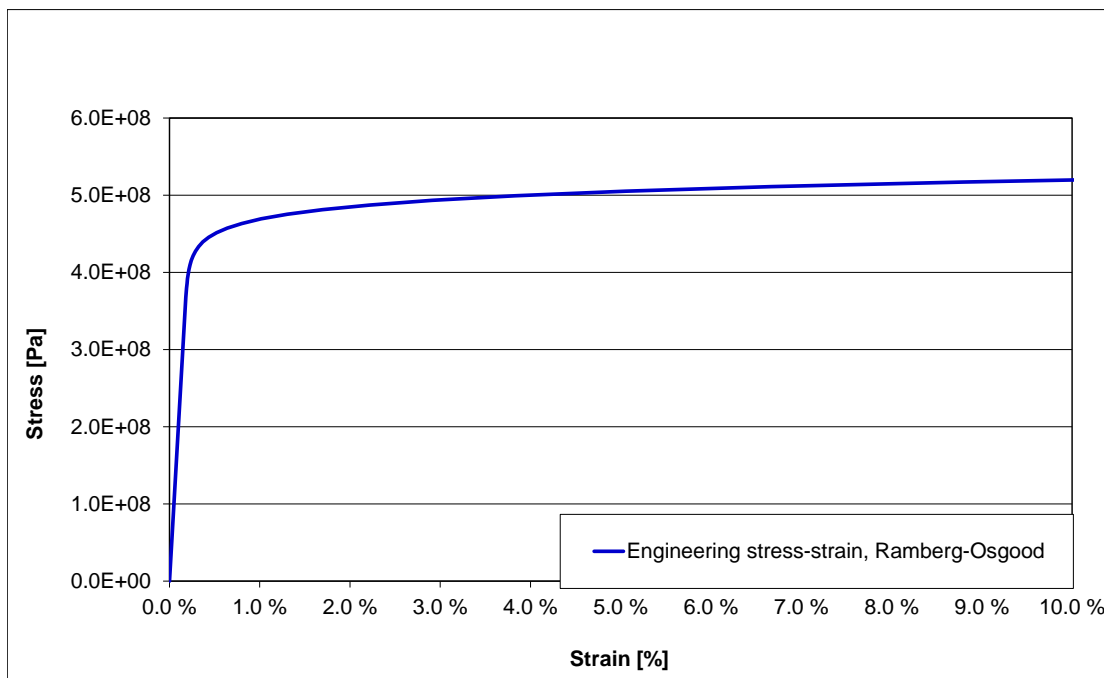

Figure 5-7: Ramberg-Osgood stress-strain curve of base material of the pipe

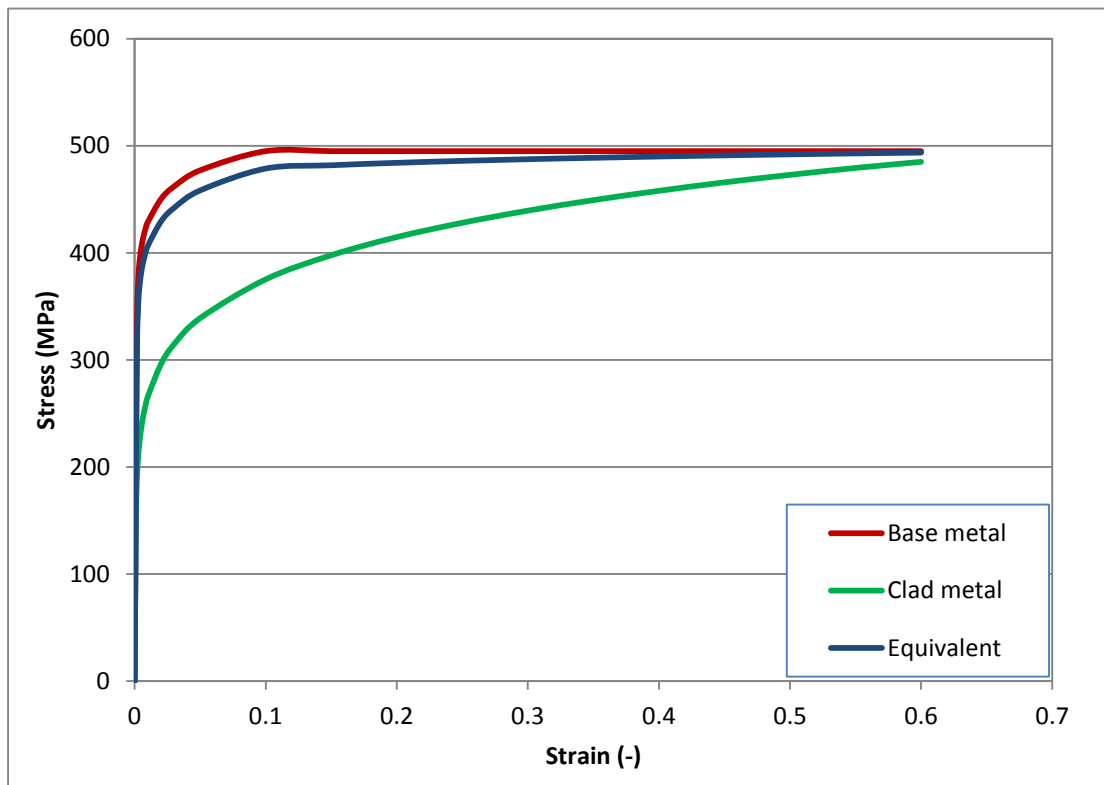

Figure 5-8: Stress-Strain Characteristics of 14'' pipeline including clad material

5.3.5 Seabed Modelling

For both snake-lay and residual curvature methods, the seabed was modelled as a flat surface by using ANSYS's target elements named as TARGE170. The Contact between the pipe and seabed in the FE model was established by defining 3-D node-to-surface contact using the contact element named as CONTA175. These target elements (TARGE170) form a contact pair with the contact elements (CONTA175) on the pipeline. The contact element is capable of orthotropic friction, which will follow the pipe deflection/movement.

5.3.6 Boundary Conditions and Load Steps

The seabed forms the main boundary condition for the pipeline. Both ends were initially fixed, but were released as per the physics of the load steps of the analysis.

Assuming that the relevant out-of-straightness sections are the starting points, the following analysis steps are applicable for both methods of snake-lay and residual curvature lay:

METHODOLOGY

- The pipeline was modeled and laid on the flat/even seabed under an ambient temperature.
- Loading due to equivalent submerged weight of the pipe is included by applying a gravity field in vertical direction (in chosen coordinate system in modelling).
- The external and operating internal pressure were applied as distributed element loading.
- Trawl pull-over load were applied.
- Axial feed-in at the ends of the pipeline model was applied in different steps until the predicted capacity of the pipe reaches the applicable capacity.

6. DESIGN DATA AND CASE STUDIES

This section presents the basic input data relevant for detailed FE analyses to check the pipeline susceptibility to lateral buckling due to operational loads. The pipeline data and operational data used in the present work are based on reasonable assumptions. The data used for the analyses of trawl interference with subsea pipelines are based on DNV-RP-F111.

6.1 Design Data

6.1.1 Pipeline Data

Table 6-1 presents the geometry and material properties of for 22” and 14” pipelines.

Table 6-1: Pipeline data

Description	Unit	22” Pipeline	14” Pipeline
Pipeline material grade	-	DNV-450	DNV-450
Outer diameter	mm	559	355.6
Wall thickness	mm	19.1	19.1
Liner/Clad layer thickness	mm	-	3
Steel density	Kg/m ³	7850	7850
Density of Liner/Clad layer	Kg/m ³	-	8000
Young’s modulus	GPa	207	207
Poisson’s ratio	-	0.3	0.3
Expansion coefficient (α)	°C ⁻¹	1.17E-5	1.17E-5
External coating thickness	mm	5	75
External coating density	Kg/m ³	910	750
Concrete coating thickness	mm	55	-
Concrete coating density	Kg/m ³	2400	-

6.1.2 Operational Data

Table 6-2 presents operational data for 22” and 14” pipeline.

Table 6-2: Operational data

Description	Unit	22” Pipeline	14” Pipeline
Max. operating temperature	°C	95	130
Ambient temperature	°C	5	5
Operating pressure	bar	150	322
Content density	Kg/m ³	900	632

6.1.3 Environmental Data

Table 6-3 presents environmental data.

Table 6-3: Environmental data

Description	Unit	22” Pipeline	14” Pipeline
Water depth	m	800	300
Sea water density	Kg/m ³	1025	1025

6.1.4 Pipe-Soil Interaction Data

Table 6-4 presents data for friction coefficients.

Table 6-4: Friction coefficients

Pipeline	Direction	Lower Bound (LB)	Best Estimate (BE)	Upper Bound (UB)
22” Pipeline	Axial	0.35	0.50	0.70
	Lateral	0.60	0.80	1.00
14” Pipeline	Axial	0.30	0.45	0.70
	Lateral	0.50	0.60	0.80

6.1.5 Trawl Gear Data

This section presents appropriate data for the largest Trawl boards, Beam trawls and Clump weight which are used in the North Sea and the Norwegian Sea. The data presented in Table 6-5 is based on DNV-RP-F111.

Table 6-5: Trawl gear data (DNV, 2010)

Parameter	Unit	Trawl Gear Type			
		Polyvalent Rectangular	Industrial V-board	Beam trawl	Clump Weight
Steel mass, m_t	kg	4500	5000	5500	9000
Dimension, Lxh	m	4.5x3.5	4.9x3.8	17.0 ³⁾	2)
Effective impact velocity	m/s	2.8 C_h^1	1.8 C_h^1	3.4	2.8
In plane stiffness, k_i	MN/m	500	500	-	4200
Bending board stiffness, k_b	MN/m	10	10	-	-
Hydrodynamic added mass, m_a	kg	2.14 m_t	2.90 m_t	1500	3140
Pull-over duration coeff. C_T	-	2.0	2.0	1.5	- ¹

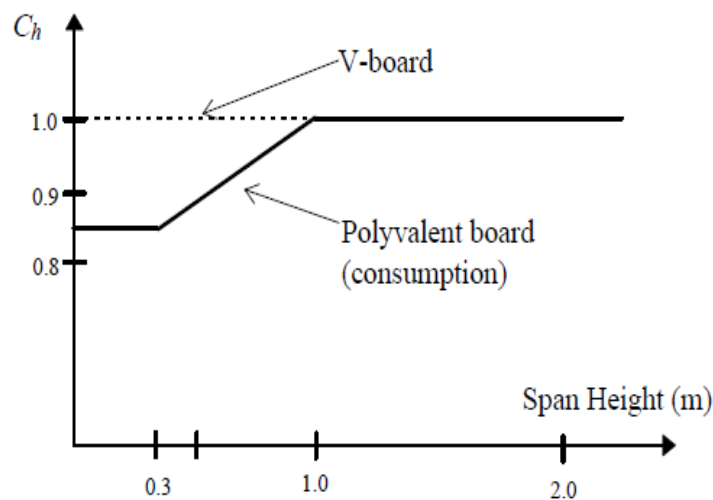

Figure 6-1: C_h coefficient for effect of span height on impact velocity (DNV, 2010)

¹ The factor C_h (span height correction factor) is given in Figure 6-1.

² Typical dimension of the largest roller clump weight of 9T are L= 4 m wide by 0.76m dia. cross section

³ Beam Trawl length (i.e. distance between outside of each shoe).

6.2 Temperature Profile

The temperatures decreases along the pipeline especially in uninsulated case due to the effect of heat loss through the pipeline walls to the ambient environment, i.e. the content temperature tends to decay with increasing distance along the pipeline. And hence an assessment of lateral buckling based on constant temperature may be conservative.

The temperature profile can be represented by exponential function in a relation to the ambient and inlet temperature.

The temperature profile can be represented by exponential function which is given as (Palmer & Ling, 1981):

$$\Delta T(x) = \Delta T_1 \cdot \exp\left(\frac{-x}{\lambda}\right) \quad (6-1)$$

Where:

x = The distance along the pipeline

ΔT_1 = Temperature differential at the pipeline end

λ = Temperature profile decay length

The temperature profile for the 10km pipeline considered in the thesis work is as shown below in Figure 6-2.

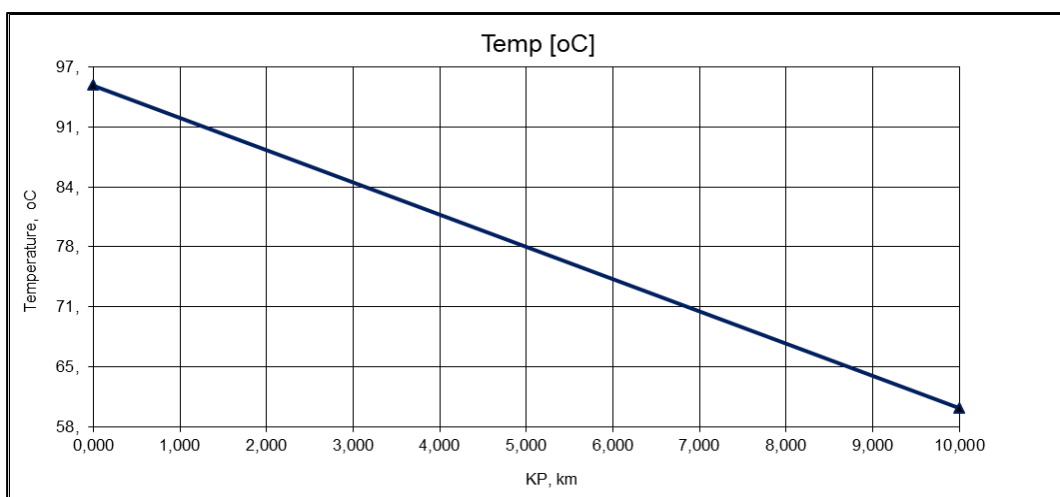

Figure 6-2: Temperature profile for 10km pipeline of 22”

6.3 DNV-OS-F101 Pipe Material Strength

DNV-OS-F101 (2013) presents curves for de-rating of yield strength of pipe materials. The characteristic yield and tensile strengths of a pipe material are given as:

$$f_y = (SMYS - f_{y,temp}) \cdot \alpha_U \tag{6-2}$$

$$f_u = (SMTS - f_{u,temp}) \cdot \alpha_U \tag{6-3}$$

Where: $f_{y,temp}$ and $f_{u,temp}$, are the strength de-rating values for elevated temperatures.

α_U = Material strength factor which is normally taken as 0.96

The Figure 6-4 below shows the de-rated steel yield strength for X65 pipe material, which was considered in the finite element analyses.

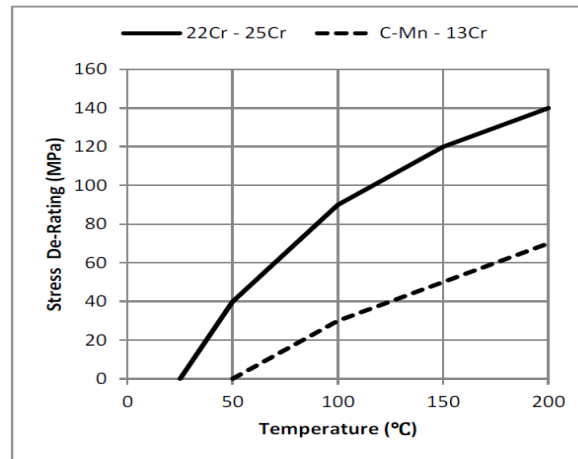

Figure 6-3: De-rating of yield strength values (DNV, 2013)

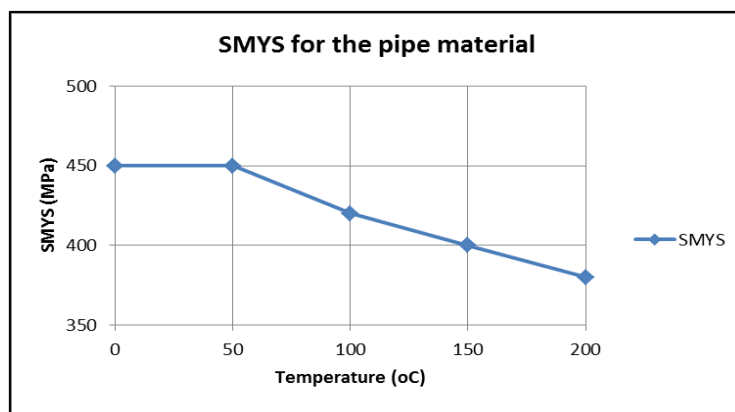

Figure 6-4: De-rated yield strength of Pipe material X65

6.4 Case Studies

6.4.1 22" Pipeline

The following case studies were established for 22" pipeline:

- Evaluation and estimation of pipeline end expansions for both hot and cold ends using both finite element analyses and analytical calculation. Based on the results, deduction of active friction length and effective force at both hot end anchor point and cold end anchor points
- Lateral buckling screening verification for the pipeline considering lower bound, best estimate and upper bound soil friction coefficients.
- Lateral buckling mitigation and controlling mechanism using **snake-lay** buckling initiation method.
- Estimation of Pull-over loads and pull-over durations for trawl gear types from DNV-RP-F111 (2010). FE analyses were performed with and without trawl pull-over load and the results were compared and discussed.
- For 14" pipeline, the trawl pull-over load was a project specific value from Subsea 7 and it is used in the analysis.

6.4.2 14" Pipeline

The following case studies were established for 14" pipeline:

- Lateral buckling screening verification for the pipeline considering lower bound, best estimate and upper bound soil friction coefficients.
- Lateral buckling mitigation and controlling mechanism using **residual curvature lay** method.
- FE analyses were performed with trawl pull-over load and the results are presented and discussed. The trawl pull-over load was a project specific value (200kN) from Subsea 7 and it is used in the analysis.

7. RESULTS AND DISCUSSION FOR 22” PIPELINE: SNAKE-LAY

All results from the design of lateral buckling analysis including trawl pull-over loads and durations will be presented in this chapter. All the detailed calculations can be found in the Appendixes.

7.1 Pipeline End Expansions

The pipeline end expansion calculations are performed in accordance with DNV-OS-F101. The free end of the pipeline will move due to combined effects of pressure, temperature and Poisson’s effect. Friction due to self-weight of the pipeline on the sea bed will act to resist this movement. It builds up over an active length to the point where the friction force equals the fully restrained axial force. At this point the pipeline will not expand and it is normally called the soil anchor point. Over this active length, the stress in the pipe wall varies from the free end to the soil anchor point.

Pipeline movements due to thermal axial expansion shall be allowed for near platforms/structures (e.g. at riser tie-in point) and where the pipeline changes direction (e.g. at off-set spools). The expansion calculations shall be based upon conservative values for the axial frictional resistance. Sensitivity analyses have been conducted to identify the important parameters which affect the pipeline end expansion. Both analytical results and results from FE analysis have been used for comparison.

As mentioned previously, a pipeline is considered as a long pipeline when the pipeline has sufficient active length to develop and mobilize friction. Long pipelines result in two anchor points towards both hot and cold ends and will experience an axial movement towards each end of the pipeline.

The expansion calculations were performed for the selected pipeline of 10km length. The results for end expansions have been presented in Table 7-1. The results from the table show that the pipeline end expansions decrease as the coefficient of friction increases, i.e. the available axial friction force increases to resist the longitudinal expansion of the pipeline. The same reason applies for the effective force at anchor points, i.e. the effective force increases as the coefficient of friction increases from the lower bound to the upper bound values.

RESULTS AND DISCUSSION FOR 22" PIPELINE: SNAKE-LAY

Conversely, the active friction length, where the friction force mobilizes to resist the driving force, decreases from lower bound to upper bound friction. In other words, this is due to that increased friction builds the enough restrained force over a less active length.

Table 7-1: Results for end expansion for 10km pipeline for varying axial friction

Axial Friction	End expansion (m)				Friction length (m)		Fully Restrained Effective force (kN)	
	FEA		Analytical					
	Hot end	Cold end	Hot end	Cold end	Hot end	Cold end	Hot end	Cold end
LB	2.36	1.21	2,20	1.27	5000.0	5000.0	-5866.3	-5866.3
BE	1.76	0.81	1.61	0.85	4318.5	4056.4	-7238.1	-6798.7
UB	1.27	0.56	1.19	0.59	3219.9	2758.3	-7555.6	-6472.5

It can be observed from Table 7-1, the 10km pipeline gets sufficient active length to mobilize the friction and hence it develops two virtual anchor points towards both hot and cold ends. The pipeline which is fully constrained in between these two actual anchor points will be susceptible to lateral buckling. The region which is prone to lateral buckling requires further assessment. Therefore, FE analyses were conducted to assess the behavior of the pipeline under operational loads.

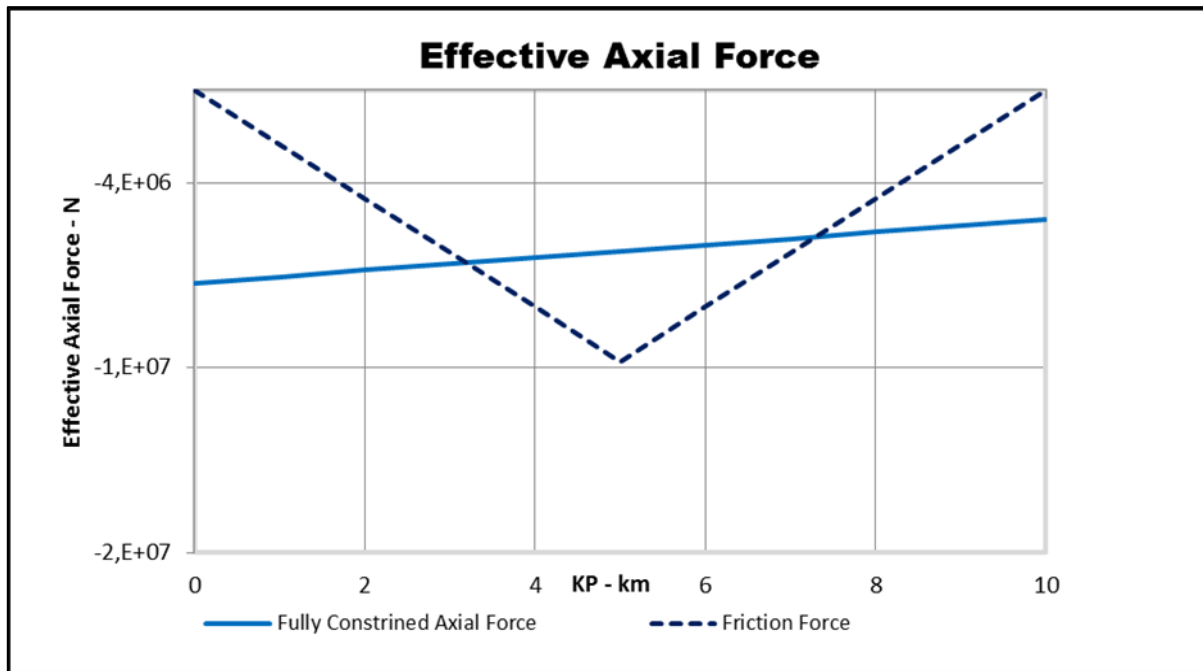

Figure 7-1: Effective axial force for 10km pipeline

7.2 Hobbs Analytical Method

The calculation of buckling forces for all mode shapes is generally performed in accordance with Hobbs method. The Hobbs method is used in preliminary analysis to determine the pipeline's susceptibility to lateral buckling. This is a well-established method and widely used and accepted method in the industry. The effective axial compressive force drives the onset of lateral buckling. The pipeline is susceptible to lateral buckling if the effective force in the pipeline exceeds the limiting force given by the Hobbs calculation, i.e. $F_{\max} \geq F_C$

Where:

F_{\max} = The maximum axial driving force due to temperature and pressure

F_C = The critical buckling force

And as mentioned in previous section, the critical buckling force is the minimum of the critical buckling force due to out of straightness and Hobbs critical buckling force.

Hobbs critical buckling forces for different mode of buckling were calculated based on the lateral buckling coefficients presented in Table 2-1. Figure 7-2 presents Hobbs critical buckling force for each mode. Table 7-2 presents Hobbs critical buckling forces calculated for

RESULTS AND DISCUSSION FOR 22" PIPELINE: SNAKE-LAY

the different modes considering different friction coefficients. The detailed calculations can be found in Appendix-B.

From Table 7-2, Hobbs critical buckling forces for different lateral coefficients are identified as:

$$P_{cr}^{LB} = 2926.73\text{kN}, P_{cr}^{BE} = 3414.60\text{kN} \text{ and } P_{cr}^{UB} = 3848.7\text{kN}$$

Table 7-2: Hobbs critical buckling forces

Buckle mode	Unit	Hobbs critical buckling force		
		$\mu_{Lat} = 0.6$	$\mu_{Lat} = 0.8$	$\mu_{Lat} = 1.0$
Mode 1	kN	-3085.81	-3604.77	-4065.07
Mode 2	kN	-2984.45	-3481.92	-3924.65
Mode 3	kN	-2934.65	-3424.92	-3855.29
Mode 4	kN	-2926.73	-3414.60	-3848.70
Mode ∞	kN	-3675.43	-4244.03	-4744.96

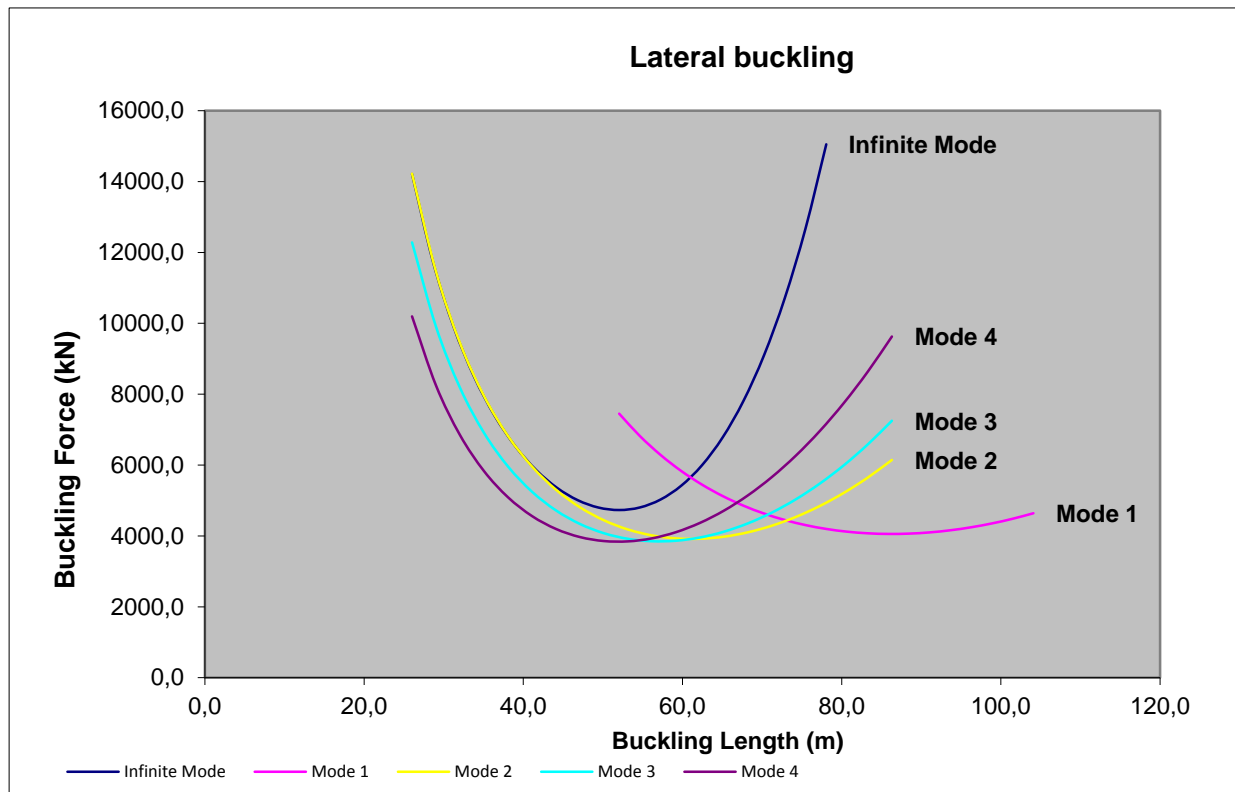

Figure 7-2: Hobbs critical buckling force for each mode for 22" pipeline

It is known that Hobbs method does not consider pipeline imperfections i.e., out-of-straightness. Hence, this method is used only as a screening check for the susceptibility of the given pipeline to lateral buckling. Practically there is no pipeline which is perfectly straight without out-of-straightness. Therefore, the Hobbs critical buckling force has to be compared with the buckling force due to out-of-straightness for a radius.

Table 7-3 and Table 7-4 present the buckling forces for out-of straightness radii of R=2000m and R=1500m for the given lateral friction coefficients.

Table 7-3: Buckling force due to OOS radius of R=2000m

Lateral friction coefficients	Buckling Force due to OOS (kN)
$\mu_{Lat} = 0.6$	4022.4
$\mu_{Lat} = 0.8$	5363.2
$\mu_{Lat} = 1.0$	6704.0

Table 7-4: Buckling force due to OOS radius of R=1500m

Lateral friction coefficients	Buckling Force due to OOS (kN)
$\mu_{Lat} = 0.6$	3016.8
$\mu_{Lat} = 0.8$	4022.4
$\mu_{Lat} = 1.0$	5028.0

Based on $P_{cr} = \min(F_{oos}, F_{Hobbs})$, the critical buckling forces from Table 7-2, Table 7-3 and Table 7-4 can be summarized as follows:

$$P_{cr}^{LB} = -2926.73\text{kN}$$

$$P_{cr}^{BE} = -3414.60\text{kN}$$

$$P_{cr}^{UB} = -3848.70\text{kN}$$

Force due to OOS is 3016.8kN for OOS radius of R=1500m and it is 4022.4kN for OOS radius of 2000m. Therefore the critical buckling force is: -2926.73 kN.

Figure 7-3 presents effective axial driving force and Hobbs critical buckling forces for the pipeline. It was mentioned before that the maximum driving force for lateral buckling, F_{\max} is the minimum of the maximum axial force due to temperature and pressure and the available friction force, $F_{f_{\max}}$. From Figure 7-3, the maximum axial driving force in the pipeline for given design temperature and pressure is, $F_{\max} = 8339.63\text{kN}$.

Variation of axial driving force due to friction can be seen in Figure 7-4 .

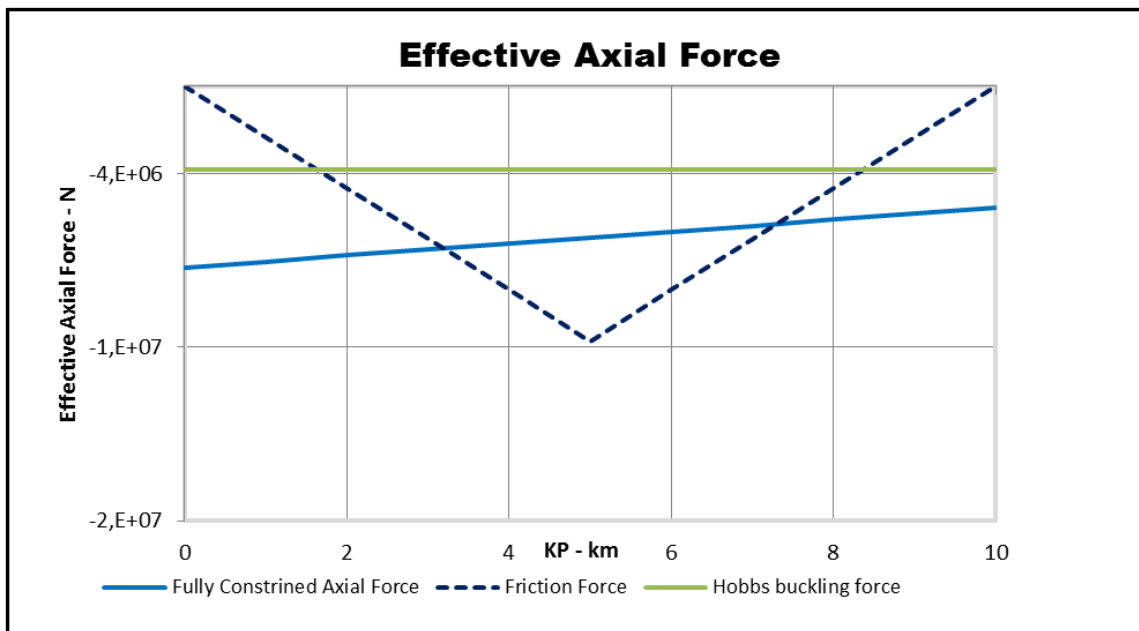

Figure 7-3: Effective axial driving force and Hobbs critical buckling forces

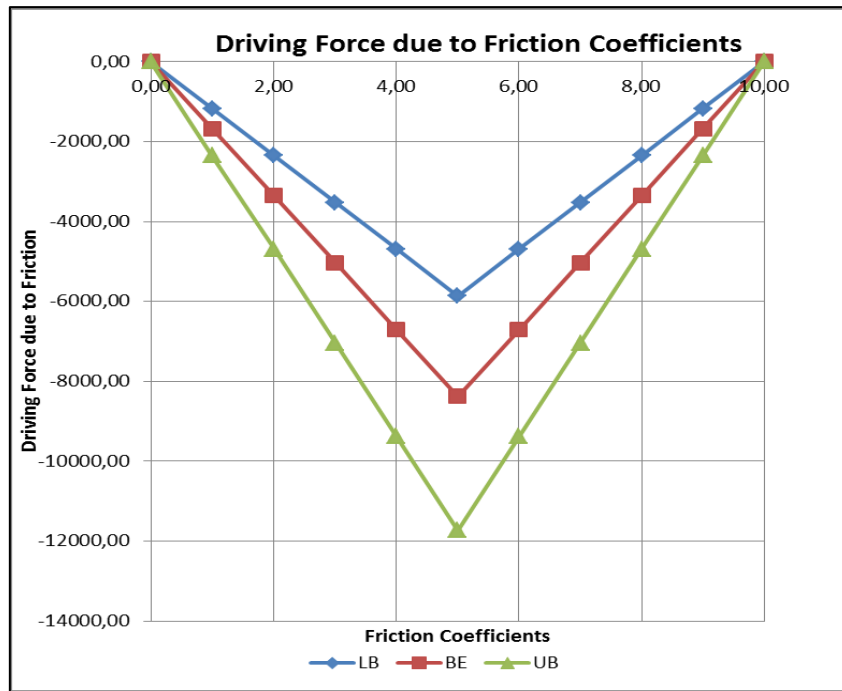

Figure 7-4: Buckle driving force due to friction coefficients

The results presented above shows that the critical buckling force is less than the maximum axial driving force, i.e.

$$P_{cr}^{UB} < F_{max}$$

, the pipeline is therefore predicted to buckle.

For pipelines that are predicted to buckle, it is required to design the pipeline such that buckling occurs under controlled conditions.

The variation of Hobbs critical buckling force with the lateral friction coefficient is shown in Figure 7-5 below. It is observed that for a pipe of given stiffness and submerged weight, the Hobbs critical buckling force increases as the soil friction increases. This is due to the fact that the buckle length in the semi-empirical formula for Hobbs critical buckling force approach is inversely proportional to the friction coefficients.

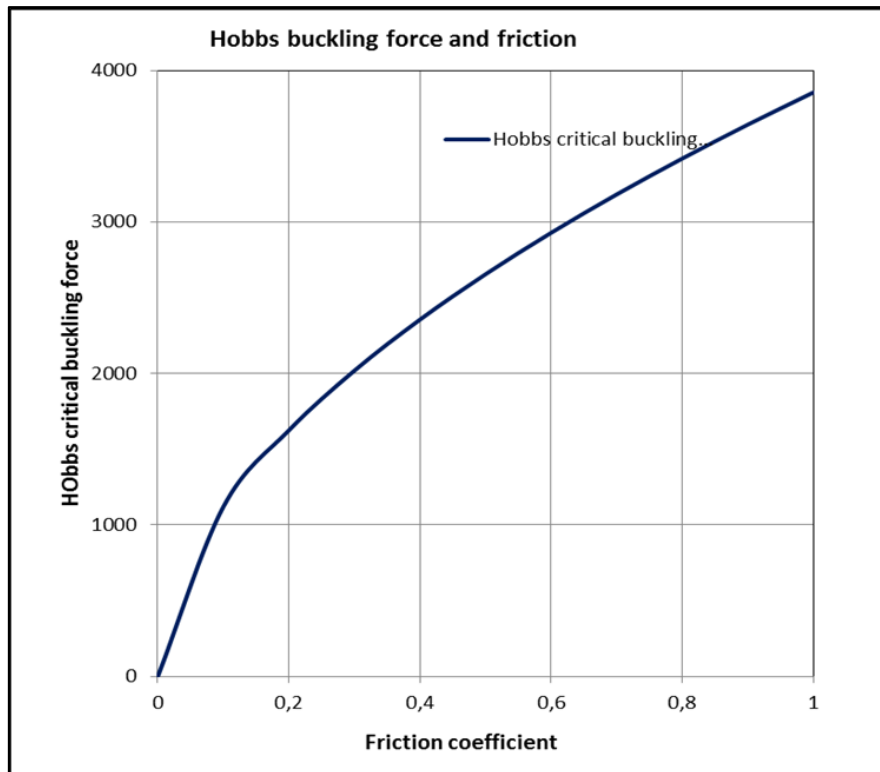

Figure 7-5: Hobbs critical buckling force versus lateral friction coefficient

As mentioned in the previous sections, the critical buckling force is the minimum of Hobbs critical buckling force and force due to out-of-straightness (OOS). The variation of axial force due to OOS with the minimum bend radius can be shown in the Figure 7-6 below.

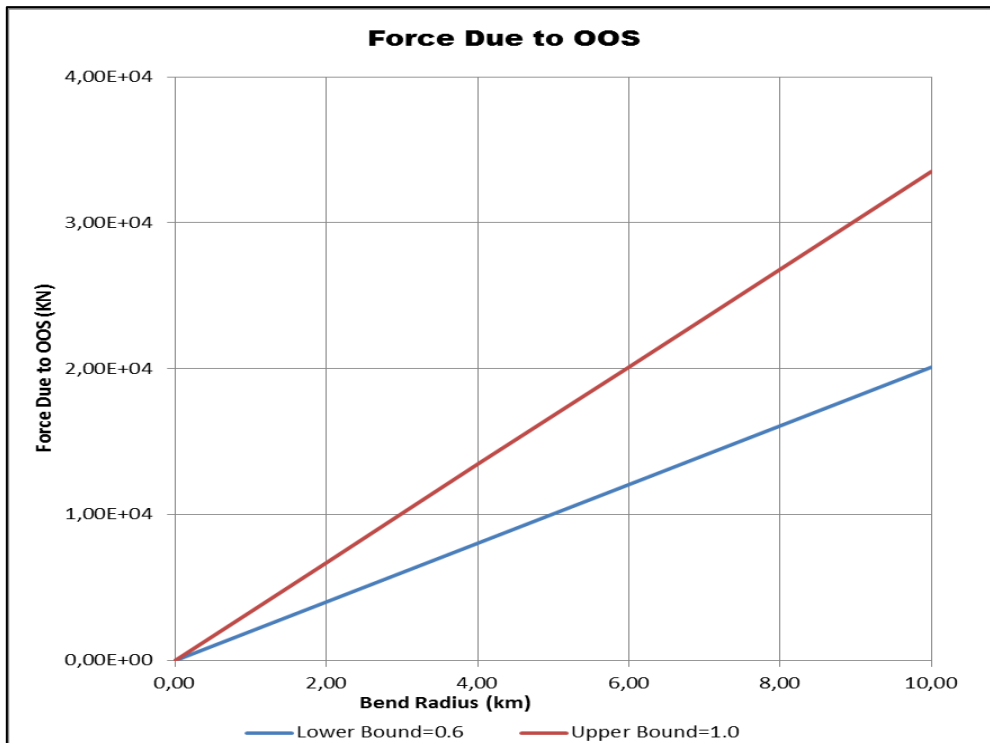

Figure 7-6: Force due to OOS versus soil friction coefficients

It can be observed from Figure 7-6 that axial force required to overcome available friction force is linearly proportional to minimum bend radius. Therefore, by increasing the minimum bend radius a proportional increase in lateral resistance is obtained, i.e. the critical buckling force is increased. This is one method of decreasing the pipelines susceptibility to lateral buckling.

7.2.1 Variation of Critical Buckling Force with Minimum Bend Radius

Figure 7-7 shows how the radius of bend affects the buckling capacity for the lower bound and upper bound soil friction coefficients.

As the minimum bend radius increases the critical buckling force increases. A crossover point is reached when the critical buckling force becomes limited by the Hobbs critical force which is not a function of bend radius. For the pipeline considered in current work, the cross over occurs at a bend radius of approximately 1.15km for upper bound soil friction. Similarly, it occurs at approximately 1.46km which is greater than the value for upper bound soil friction.

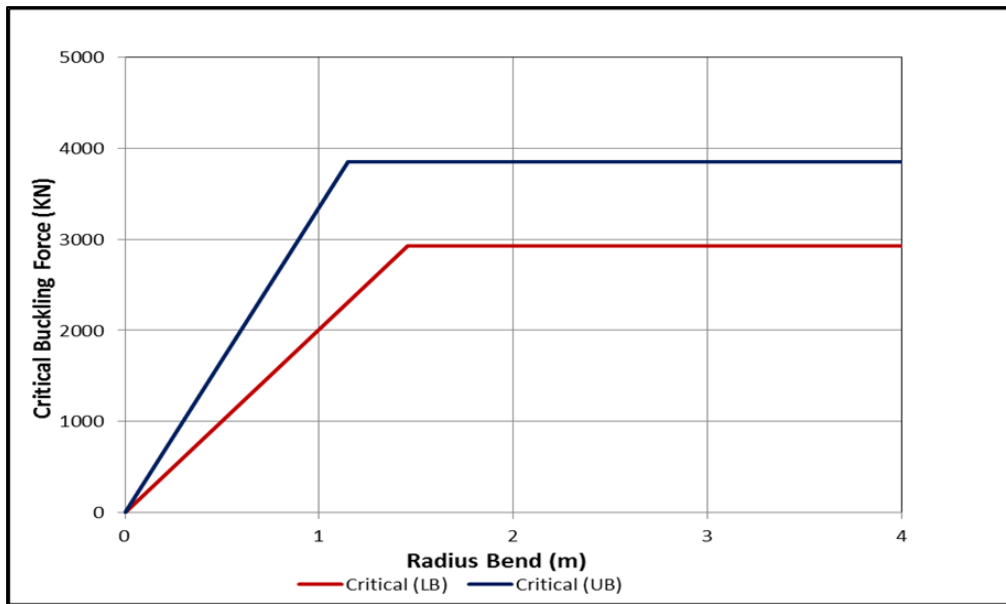

Figure 7-7: Variation of critical buckling force with minimum bend radius

7.3 Snake-lay Configuration

7.3.1 General

Snake-lay is one of the mitigation methods for lateral buckling which is basically based upon laying the pipeline with some predetermined curves along the pipeline. The aim of snake-lay is to initiate buckles in different locations such that the feed-in length generated by operational loads will be distributed at the buckle zones. As mentioned previously, sharing of expansion into adjacent buckles is considered to avoid localization where pipeline integrity could be lost. The concept of snake-lay configuration enables sharing of expansion into adjacent buckles as described in DNV-RP-F110 Global Buckling of Submarine Pipelines.

The allowable feed-in to each buckle location is the governing criteria for the controlled lateral buckling design. The allowable feed-in is determined based on the capacity of the given pipeline. DNV-RP-F110 adopts the use of DNV-OS-F101 moment capacity and strain limits to determine the allowable feed-in into each buckle location.

In order to establish the snake-lay configuration for the selected pipeline, the present work considers both load controlled criterion (LCC) and displacement controlled criterion (DCC). The calculations of the pipeline moment and strain capacity using these criteria can be found in the Appendix-G.

As mentioned, the allowable feed-in lengths for buckles will govern the final snake-lay configuration together with the critical buckling force for the upper bound lateral soil resistance and the post buckling force for lower bound lateral soil resistance.

The maximum allowable feed-in was determined from the finite element analyses and the snake-lay configuration was established to ensure that the feed-in in to buckle should be within allowable limit.

According to DNV-RP-F110 (2007), sharing between the buckles at the location of OOS happens if the following mathematical formulation is satisfied:

$$S_{R,1} + \Delta S \geq S_{G,2}$$

Where:

$S_{R,1}$: post buckle effective axial force in the first buckle

ΔS : Axial force built-up between adjacent buckles calculated by lower bound (LB) soil characteristics.

$S_{G,2}$: Axial buckling capacity force for the second buckle.

7.3.2 Snake-lay Configuration: Displacement Controlled Criterion

The FE analyses were performed to obtain the post buckling force for several combinations of the lower bound, best estimate and upper bound soil friction coefficients. Table 7-5 summarizes the predicted values. The results in the table are based on the selected OOS radius of 2000m.

Using the results from Table 7-5, the snake-lay configuration was generated for the given pipeline. Figure 7-8 presents the established snake-lay configuration and distribution of effective axial force for the 10km pipeline. The resulting expansion distribution can be seen in Figure 7-9. It is seen that seven snakes are required to share the allowable feed-in capacity. The snakes were generated using the OOS radius of 2000m, the upper critical buckling force of -3848.7 kN and the lower bound post buckling force of -1648 kN.

Table 7-6 presents the virtual anchor spacing and compares the allowable and predicted feed-in lengths. The predicted results are within the allowable limit.

RESULTS AND DISCUSSION FOR 22" PIPELINE: SNAKE-LAY

Rock dumping was applied at both pipeline ends to reduce the end expansion of the pipeline so that it shall be within the expansion capacity of the spool which is assumed to be 1.0m.

Figure 7-10 compares effective axial force distribution for planned and unplanned buckling scenarios. The seven snakes will absorb the total pipeline end expansion through distributing the feed-in among the purposely formed thermal buckles.

Table 7-5: Allowable feed-in for different soil friction coefficients

Axial Friction Coefficient	Lateral Friction Coefficient	Critical Buckling Force (kN)	Post Buckling Force (kN)	Allowable strain limit ϵ_{ca} (m/m)	Allowable feed-in (m)
LB	LB	-2926.70	1648.00	0.004	1.64
BE	BE	-3414.60	1783.00	0.004	1.54
BE	UB	-3848.70	1814.00	0.004	1.43
UB	UB	-3848.70	1876.00	0.004	1.47

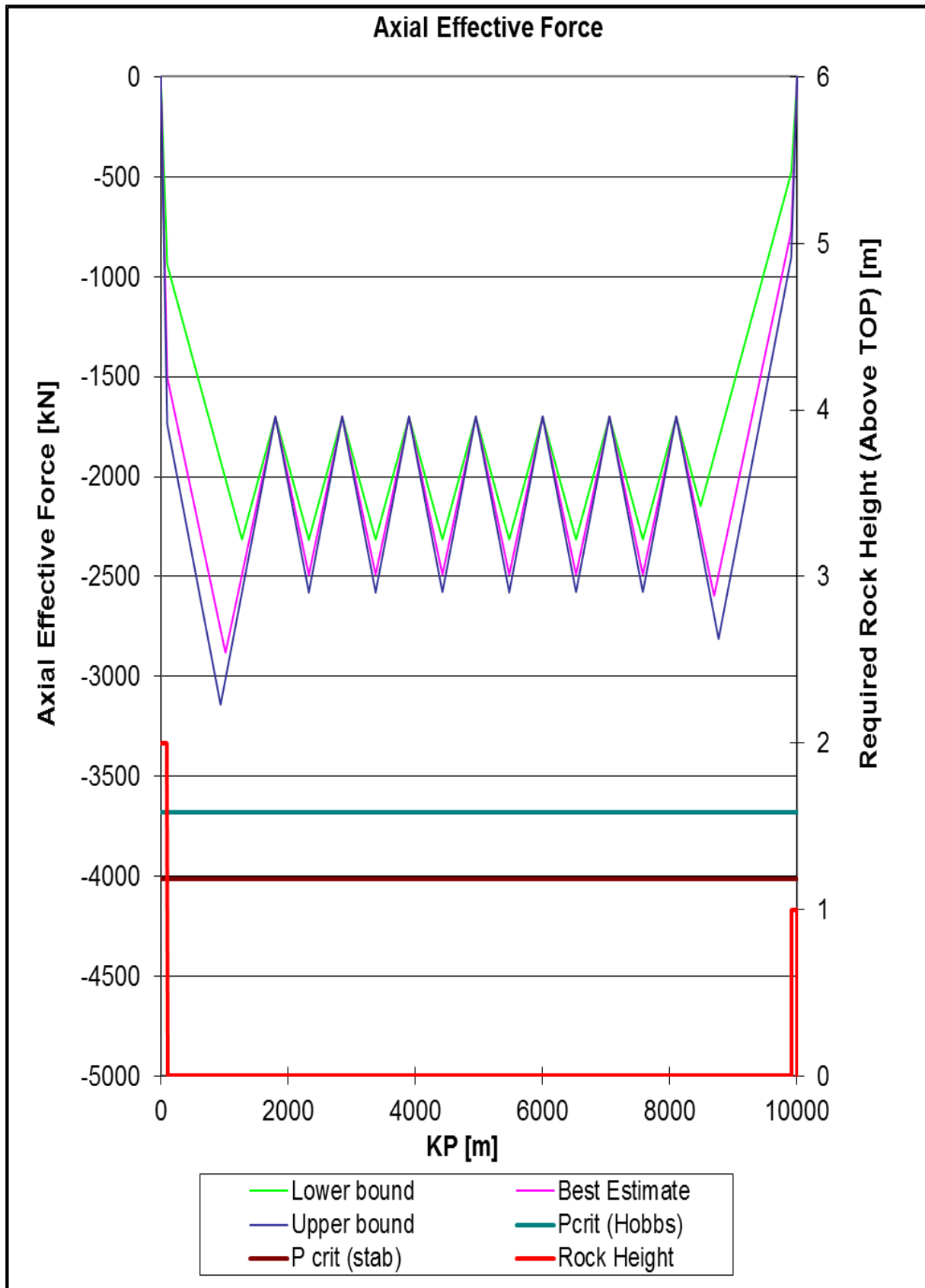

Figure 7-8: Effective axial force distribution for 22" pipeline

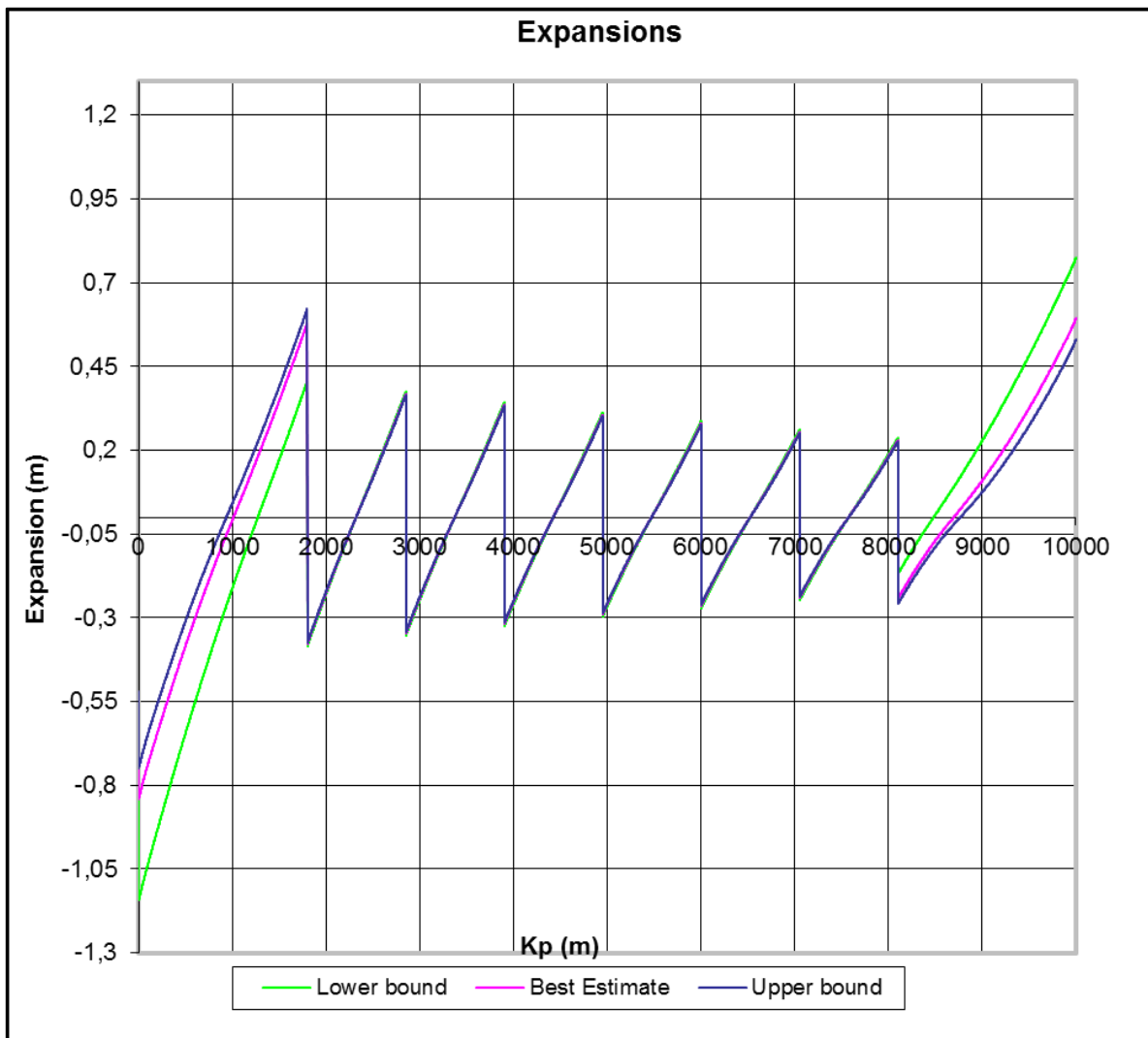

Figure 7-9: Expansion distribution for 22" pipeline

Table 7-6: Snake configuration for 22" pipeline

Description	Lay radius(m)	Virtual Anchor point 1 (m)	Virtual Anchor Point 2 (m)	Calculated Feed-in (m)	Maximum allowable feed-in (m)
Hot end	2000	Free end	906	1.10	-
Snake 1	2000	906	2318	0.97	1.43
Snake 2	2000	2308	3354	0.70	1.43
Snake 3	2000	3354	4406	0.64	1.43
Snake 4	2000	4406	5454	0.58	1.43
Snake 5	2000	5454	6512	0.52	1.43
Snake 6	2000	6512	7554	0.48	1.43
Snake 7	2000	7554	8752	0.47	1.43
Cold end	2000	8752	Free end	0.77	-

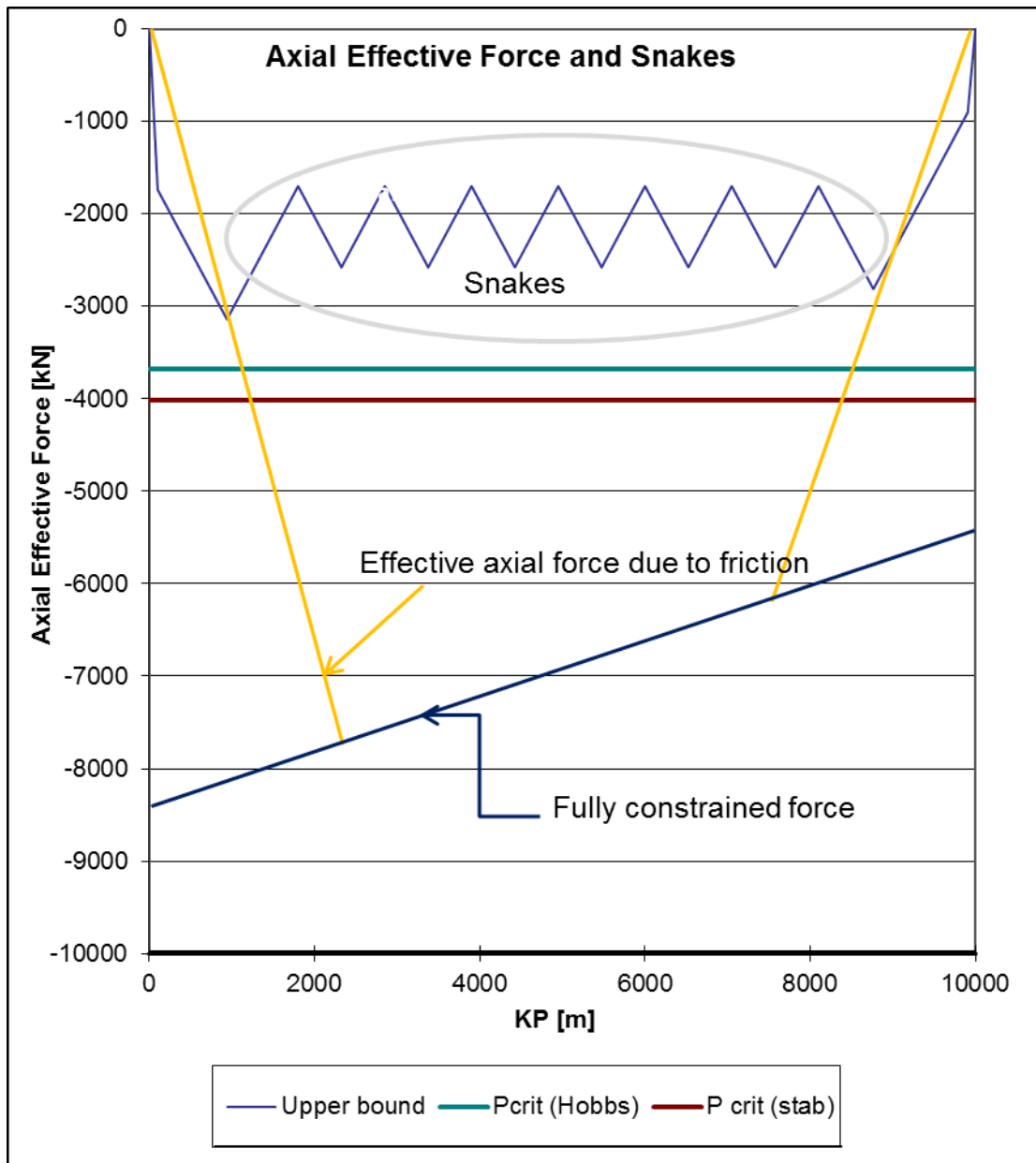

Figure 7-10: Effective axial driving forces and the pre-determined snakes distribution

7.3.3 Snake-lay Configuration: Load Controlled Criterion (LCC)

The load controlled criterion (LCC) is another criterion which is used to calculate the pipeline capacity. It is based on DNV-OS-F101 and its formulation is described in section 2.7. In the load controlled criterion, the pipeline capacity is determined in terms of moment capacity by applying several safety factors described below.

The load condition factor (γ_c) was calculated by developing an excel spreadsheet according to DNV-RP-F110 methodology, where the bending moment response is determined using FE analyses. The design moment, M_d , was calculated by considering the partial safety factors, i.e. γ_c and γ_f . From the developed excel spreadsheet considering all the soil friction coefficients, γ_c was estimated to be 0.8. The partial safety factor for the functional loads, γ_F is assumed to be 1.0.

Table 7-7 summarizes the allowable feed-in was calculated for the three cases, i.e. for lower bound, best estimate and upper bound soil friction coefficients. Once the limiting criteria for sharing principle is determined, i.e. allowable feed-in, post buckling force, and critical buckling force, the snakes has been be generated using Excel spreadsheet.

Figure 7-11 and Figure 7-12 present results for the snake lay configuration of the pipeline under load controlled criterion. The results are based on OOS radius of 2000m, the upper bound critical buckling force, i.e. 3848.7kN and lower bound post buckling force, i.e. -1915 kN and the allowable maximum design feed-in of 0.90m. From Figure 7-11 it can be observed that the pipeline requires 9 snakes and some rock dumping towards the pipeline ends to restrain the end expansions to be within the design limit of connected spools. The corresponding expansion distribution in the pipeline is shown in the Figure 7-12.

Table 7-8 presents the virtual anchor spacing and compares the allowable and predicted feed-in lengths. The predicted results are within the allowable limit.

Table 7-7: Allowable feed-in for different soil friction coefficients

Axial Friction Coefficients	Lateral Friction Coefficients	Critical Buckling Force (kN)	Post Buckling Force (kN)	Allowable feed-in (m)
LB	LB	-2926.70	1915.00	1.10
BE	BE	-3414.60	2010.00	0.97
BE	UB	-3848.70	2045.00	0.90
UB	UB	-3848.70	2105.00	1.05

Table 7-8: Snake Configuration for 22” pipeline

Description	Lay radius(m)	Virtual Anchor point ₁ (m)	Virtual Anchor Point ₂ (m)	Calculated Feed-in (m)	Maximum allowable feed-in (m)
Hot end	2000	Free end	862	1.10	-
Snake 1	2000	862	2092	0.87	0.90
Snake 2	2000	2092	2978	0.58	0.90
Snake 3	2000	2978	3830	0.52	0.90
Snake 4	2000	3830	4698	0.50	0.90
Snake 5	2000	4698	5564	0.46	0.90
Snake 6	2000	5564	6426	0.42	0.90
Snake 7	2000	6426	7292	0.38	0.90
Snake 8	2000	7292	8158	0.35	0.90
Snake 9	2000	8158	9570	0.44	0.90
Cold end	2000	9570	Free end	0.37	-

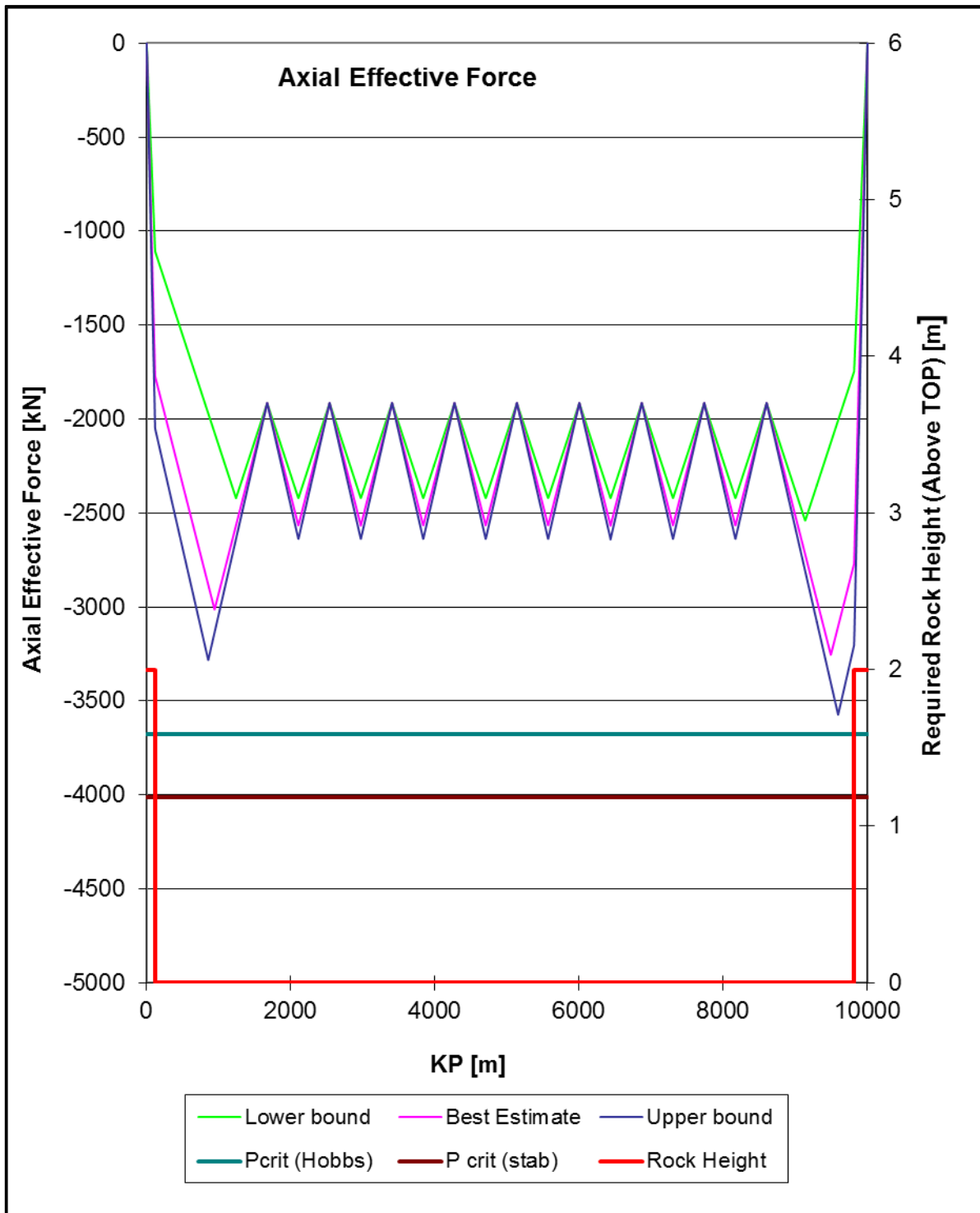

Figure 7-11: Effective axial force distribution for 22" pipeline

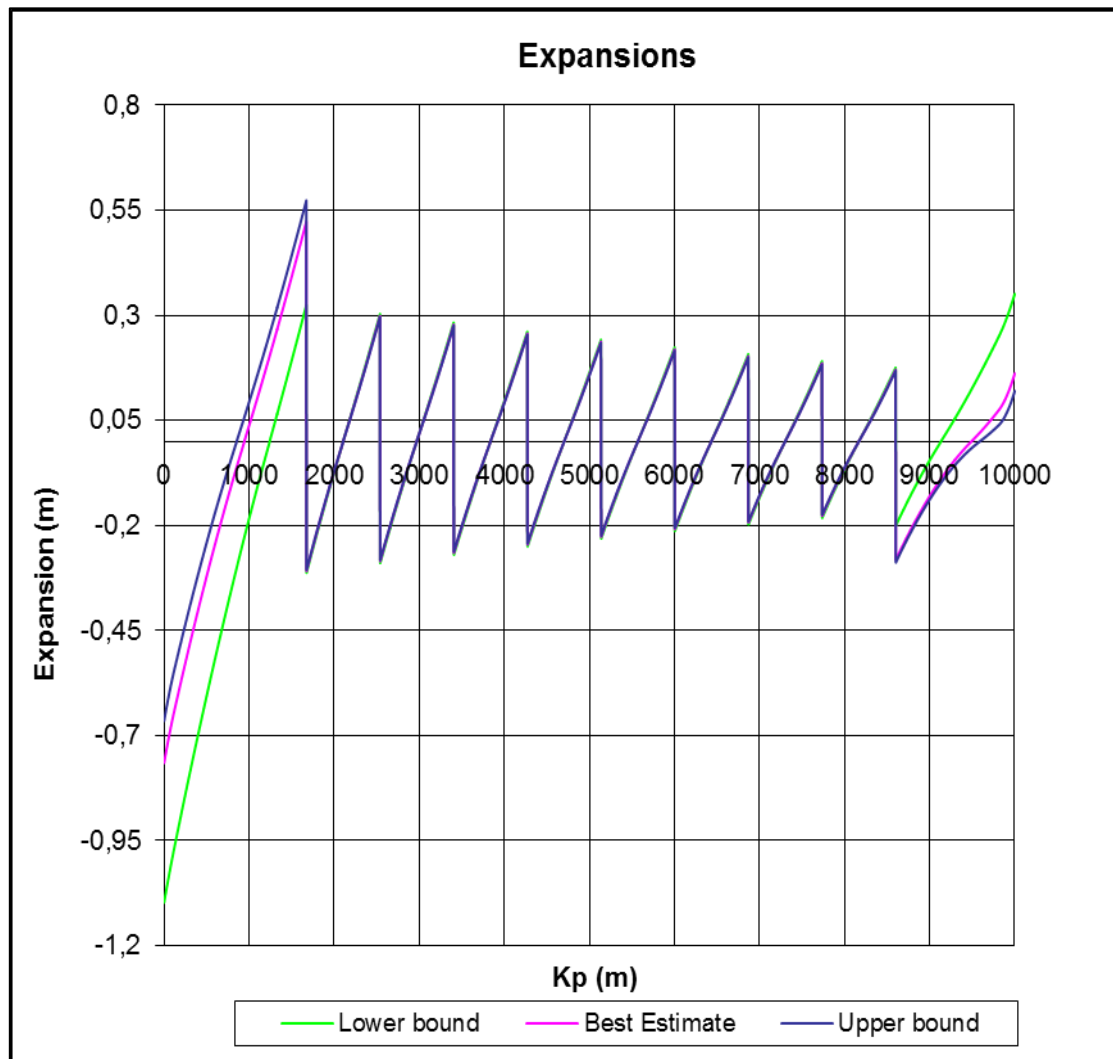

Figure 7-12: Expansion distribution for 22" Pipeline

7.4 Results for Pull-over Loads and Durations

The pull-over loads and durations are determined in accordance with the method described in DNV-RP-F111. The detailed calculations can be found in Appendix-F.

7.4.1 Pull-over Loads and Duration for Clump Weight

Table 7-9 below summarizes analytically calculated pull-over loads and durations for roller type clump weight where the input data for the calculation are taken from DNV-RP- F111.

Table 7-9: Load history curves for Clump weight

Time (s)	F_p (kN)	F_{z_up} (kN)	F_{z_down} (kN)
0.0	0.0	0.0	0
0.2	158.1	29.8	-32.8
2.4	316.2	59.5	-65.5
3.01	0.0	0.0	0.0

7.4.2 Pull-over Force and Duration for Consumption Trawl Board

Table 7-10 below presents the calculated pull-over loads and duration for the consumption trawl board where the data are taken from DNV-RP-F111.

Table 7-10: Load history for Consumption trawl board

Time (s)	F_p (kN)	F_{z_down} (kN)
0	0.0	0.0
0.45	51.2	-32.9
1.05	0.0	0.0

7.4.3 Pull-over Loads and Durations for Beam Trawl Board

Here we have only horizontal pull-over loads unlike the clump weight and consumption trawl. The results are presented in Table 7-11. Detailed analytical calculations can be found in Appendix C.

Table 7-11: Load history for Beam trawl

Time (s)	F_p (kN)
0.0	0.0
1.67	267.6
1.67	187.3
2.78	187.3
2.78	0.0

The graphical presentations of the vertical and horizontal pull-over loads for the three types of trawl gear which are considered in the present work are shown below in the Figure 7-13 and Figure 7-14. As discussed before, the beam trawl has only a horizontal pull-over load component that interacts with the subsea pipeline.

From the results plots for the pull-over loads, it is observed that the mass of the trawl, i.e. m_t , plays an important role towards the pullover loads during trawl gear interaction with subsea pipelines.

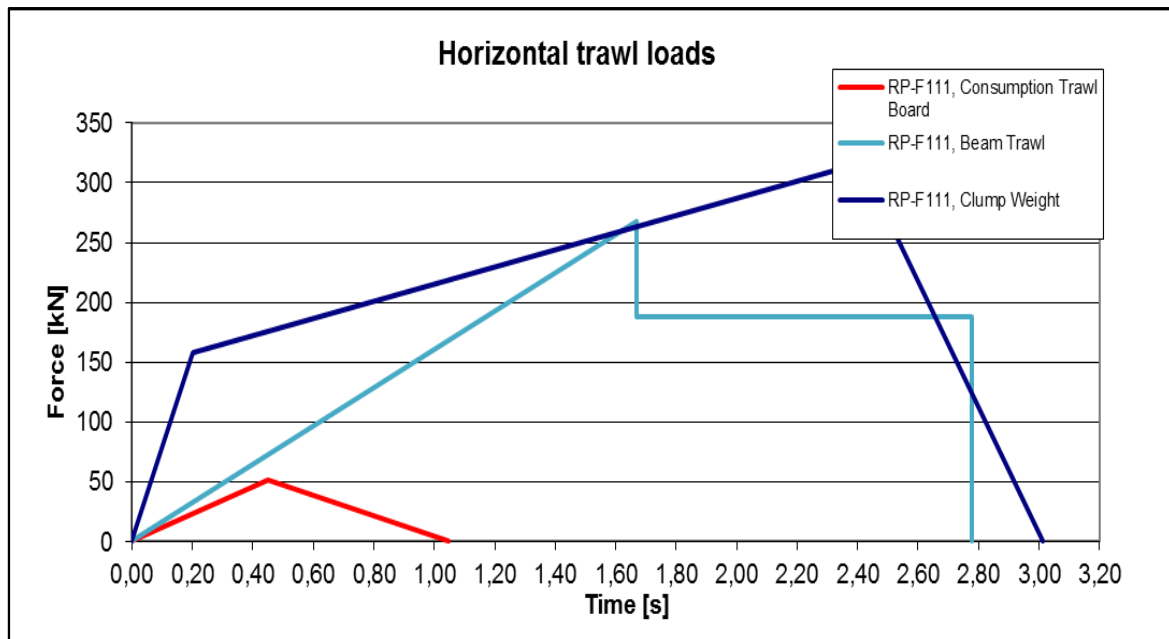

Figure 7-13: Horizontal trawl loads for Beam trawl, Consumption trawl board and Clump weight

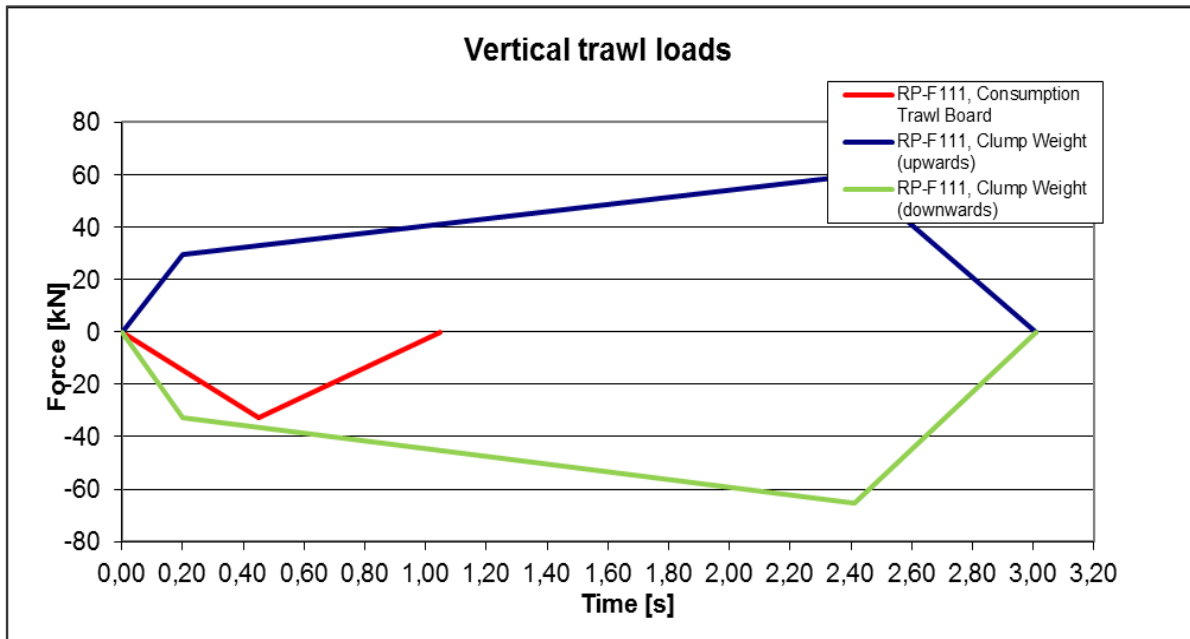

Figure 7-14: Vertical trawl loads for Clump weight and Consumption trawl board

7.5 Results for Snake-lay with Trawl Interaction

FE analyses were performed to assess the allowable feed-in lengths in a buckle considering trawl pull-over loads that are likely to occur at the snake locations. In this combined load case, the displacement controlled criterion has been used to determine the allowable feed-in lengths.

First, the analyses were performed for the three types of trawl gears assuming angle of attack 90° and the results are presented in Table 7-12. Best estimate friction is considered during trawl interaction. When this is combined with FE analyses performed for feed-in, all the three soil friction coefficients, i.e. lower bound, best estimate and upper bound were considered. As expected the allowable feed-in gets reduced when trawl pull-over loads are considered to occur at the snake locations.

Further, sensitivity analyses were performed to assess the effect of angle of attack for the two types of trawl gears with maximum pull-over loads from Clump weight and Beam trawl. The results from the analyses are summarized in Table 7-13. The results from Table 7-12 and Table 7-13 show that the allowable feed-in is minimum when the angle of attack (hit) is in 90 degree direction. It can also be observed that the trend of allowable feed-in reduces from 30 to 90 degree of angle of attack. The results from Table 7-12 and Table 7-13 further show that the

selected snake-radius with trawl interaction of Clump weight is governing the lateral buckling design. Hence, snake-lay configuration has been established for this combined load case using the results listed in Table 7-14. Figure 7-15 and Figure 7-16 present the snake-lay configuration for the 22" pipeline considering combined trawl interaction. These configurations are based on the upper bound critical buckling force of -3848.70kN and lower bound post-buckling force of 1290kN from Table 7-14. Table 7-15 shows the details of the number snake locations along the pipelines and compares the predicted feed-ins against the allowable design feed-in. From the results, it is seen that the 22" pipeline requires 14 snakes along with intermittent rock dumping as indicated in Figure 7-15.

In-summary, the results conclude that the reduced feed-in capacity under the consideration trawl pull-over load interaction makes the number of snakes to increase from 9 to 14 and the addition requirement of rock dumping.

Table 7-12: Allowable feed-in and trawl gear types with 90 degrees angle of attack

Axial Friction	Lateral Friction	Trawl load	Allowable feed-in (m)		
			Clump Weight	Consumption Trawl	Beam Trawl
LB	LB	BE	0.66	0.97	0.81
BE	BE	BE	0.61	0.83	0.66
BE	UB	BE	0.57	0.78	0.61
UB	UB	BE	0.48	0.74	0.57

RESULTS AND DISCUSSION FOR 22" PIPELINE: SNAKE-LAY

Table 7-13: Allowable feed-in with 30 and 60 degrees of angle of attack

Axial Friction	Lateral Friction	Trawl load	Allowable feed-in (m) w.r.t angle of attack			
			Clump Weight		Beam Trawl	
			30°	60°	30°	60°
LB	LB	BE	1.02	0.79	1.21	0.94
BE	BE	BE	0.82	0.67	0.96	0.83
BE	UB	BE	0.78	0.63	0.91	0.79
UB	UB	BE	0.64	0.52	0.75	0.66

Table 7-14: Allowable feed-in for different soil friction coefficients

Axial Friction	Lateral Friction	Trawl Load	Critical Buckling Force (kN)	Post Buckling Force (kN)	Allowable Feed-in (m)
LB	LB	BE	-2926.70	1290	0.66
BE	BE	BE	-3414.60	1376	0.61
BE	UB	BE	-3848.70	1413	0.57
UB	UB	BE	-3848.70	1496	0.48

Table 7-15: Snake Configuration for 22" pipeline considering trawl interference

RESULTS AND DISCUSSION FOR 22" PIPELINE: SNAKE-LAY

Description	Lay radius (m)	Virtual Anchor point ₁ (m)	Virtual Anchor Point ₂ (m)	Calculated Feed-in (m)	Maximum allowable feed-in (m)
Hot end	2000	Free end	340	0.42	-
Snake 1	2000	340	864	0.41	0.57
Snake 2	2000	864	1546	0.56	0.57
Snake 3	2000	1546	2230	0.53	0.57
Snake 4	2000	2230	2910	0.49	0.57
Snake 5	2000	2910	3590	0.48	0.57
Snake 6	2000	3590	4268	0.45	0.57
Snake 7	2000	4268	4950	0.43	0.57
Snake 8	2000	4950	5630	0.41	0.57
Snake 9	2000	5630	6312	0.38	0.57
Snake 10	2000	6312	6988	0.36	0.57
Snake 11	2000	6988	7678	0.35	0.57
Snake 12	2000	7678	8356	0.33	0.57
Snake 13	2000	8356	9036	0.31	0.57
Snake 14	2000	9036	9674	0.25	0.57
Cold end	2000	9674	Free end	0.20	-

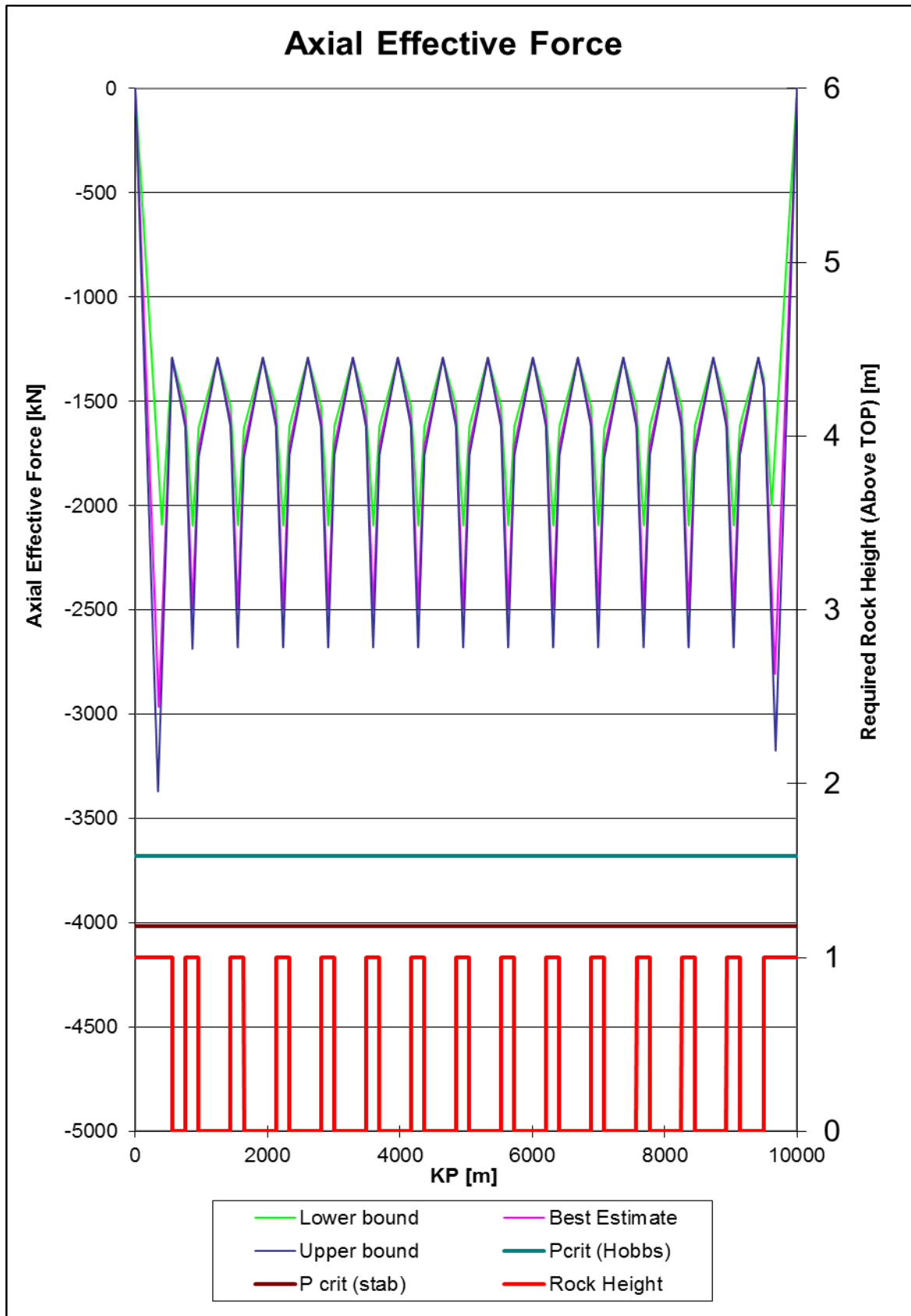

Figure 7-15: Effective axial force distribution for 22" pipeline considering trawl interference

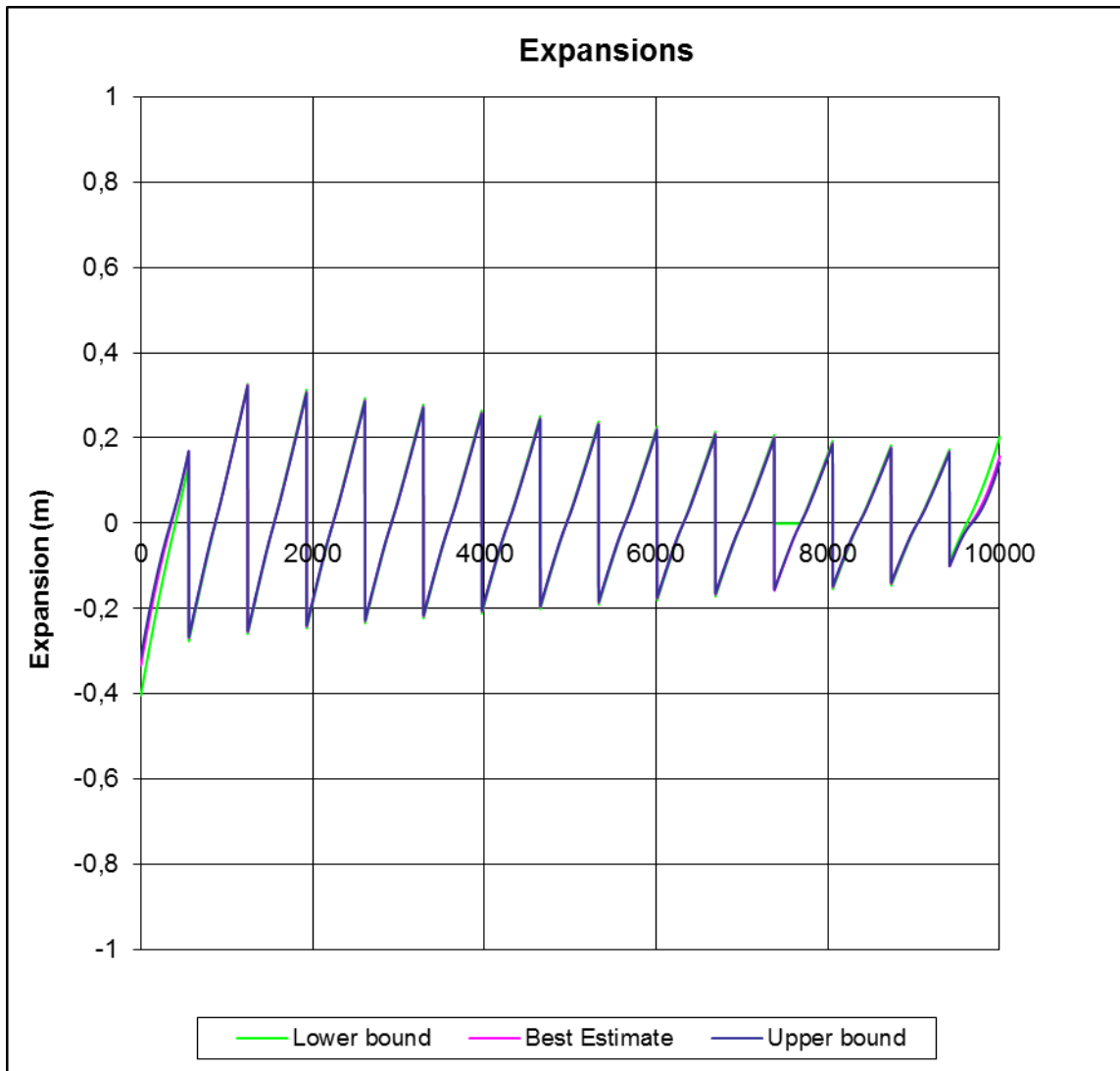

Figure 7-16: Expansion distribution for 22" pipeline considering trawl interference

8. RESULTS AND DISCUSSION FOR 14” PIPELINE: RESIDUAL CURVATURE LAY

8.1 Hobbs Screening Check

Hobbs critical buckling forces for different mode of buckling were calculated based on the lateral buckling coefficients presented in Table 2-1. Figure 8-1 presents Hobbs critical buckling force for each mode for 14” pipeline. Table 8-1 presents Hobbs critical buckling forces calculated for the different modes considering different soil friction coefficients. The detailed calculations can be found in Appendix-B.

Table 8-1: Hobbs critical buckling forces for 14” pipeline

Buckle mode	Unit	Hobbs critical buckling force		
		$\mu_{Lat} = 0.5$	$\mu_{Lat} = 0.60$	$\mu_{Lat} = 0.80$
Mode 1	kN	-919.60	-1015.30	-1186.3
Mode 2	kN	-892.70	-985.60	-1150.2
Mode 3	kN	-878.50	-968.90	-1131.0
Mode 4	kN	-879.50	-969.60	-1130.9
Mode ∞	kN	-1169.30	-1280.90	-1479.10

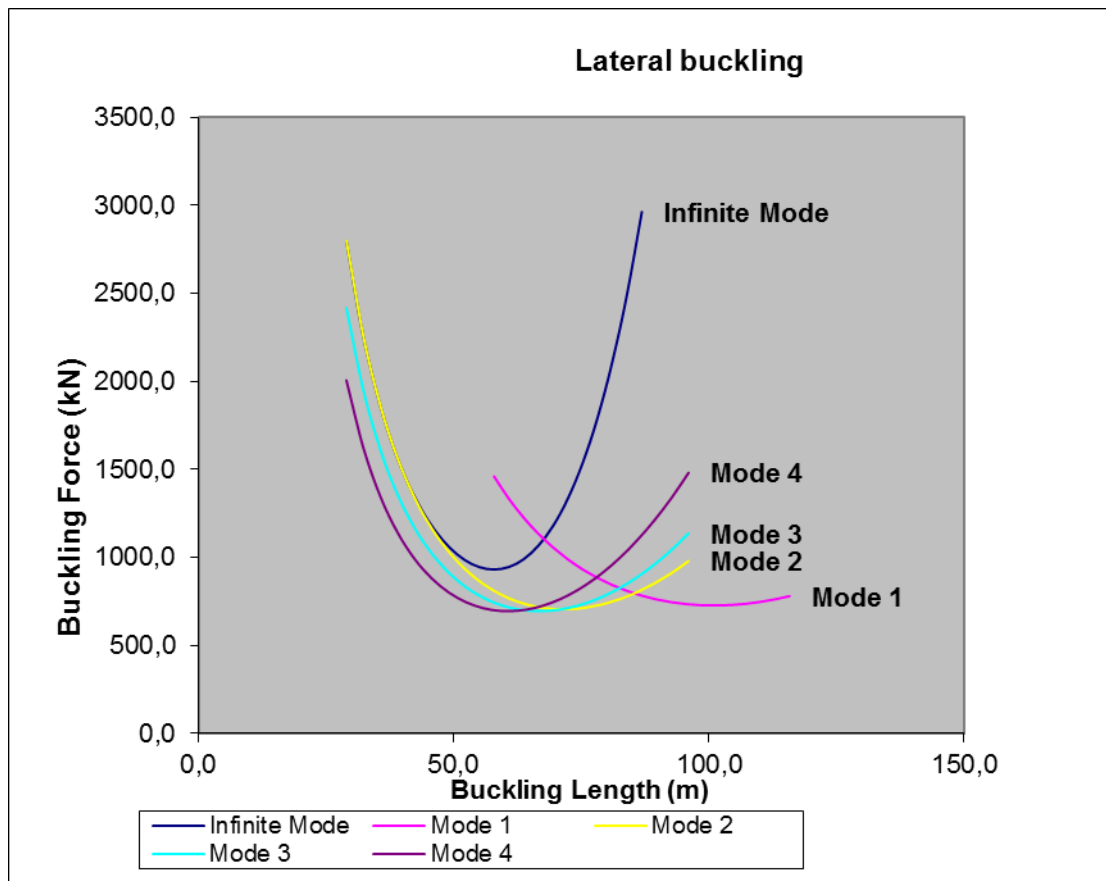

Figure 8-1: Hobbs critical buckling force for each mode for 14" pipeline

The maximum calculated driving force for lateral buckling for the selected pipeline and operational loadings which are given in Table 6-1 through Table 6-4 is 7956kN. Hence, the pipeline is predicted to lateral buckling and it requires further FEA assessment.

The FE analysis for the 14" pipeline to mitigate lateral buckling is performed by residual curvature method.

8.1.1 Residual Curvature under Load Controlled Criterion

First, using the FE model described in section 5.3.3b, the FE analyses were performed to create the residual curvature by straining the pipe to the required residual strain. Figure 8-2 and Figure 8-3 present the results for equivalent plastic strain and the total elastic plastic strain when the pipe is laterally deformed as seen in Figure 8-4. The plastic strain of 0.25% from Figure 8-2 is the required residual strain for the proposed residual curvature.

RESULTS AND DISCUSSION FOR 14" PIPELINE: RESIDUAL CURVATURE LAY

Secondly, analyses were performed by applying the feed-in at the ends of pipe model combining the specified trawl pull over load of 200kN. The specified pull over load is based on the project specific data for the selected pipeline. The allowable design feed-in was estimated based on the allowable moment capacity obtained from the load controlled design criterion. The analyses for feed-in have been performed by applying the several combinations of the lower bound, best estimate and upper bound soil friction coefficients. Trawl load was applied considering best estimate soil friction. The resulting post buckling force and allowable feed-in corresponding to the allowable moment capacity are tabulated in Table 8-2.

Table 8-2: Allowable feed-in for different soil friction coefficients

Axial Friction	Lateral Friction	Trawl Load	Critical Buckling Force (kN)	Buckling Force (kN)	Allowable Feed-in (m)
LB	LB	BE	-1186.3	210	0.75
BE	BE	BE	-1150.2	235	0.64
BE	UB	BE	-1131.0	251	0.56
UB	UB	BE	-1130.9	263	0.48

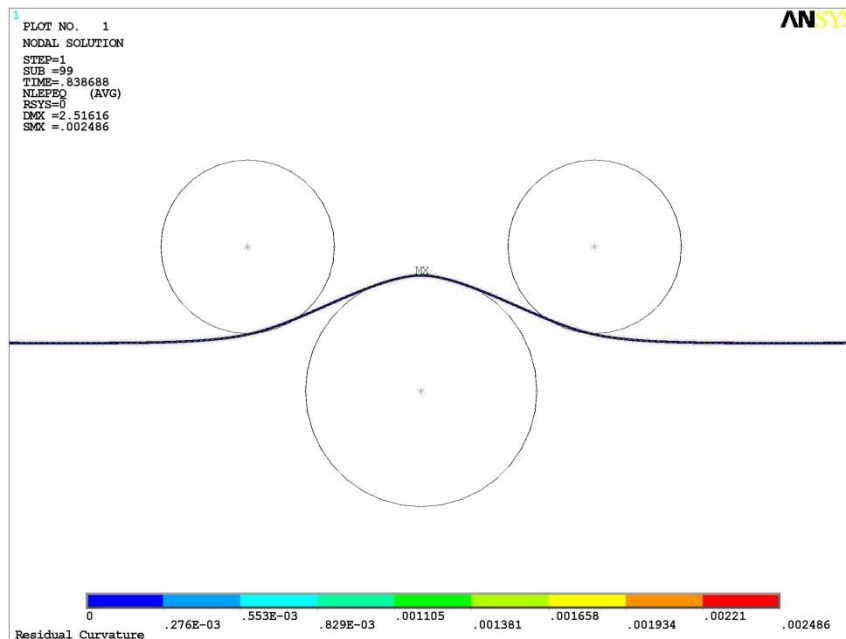

Figure 8-2: Results for equivalent plastic strain

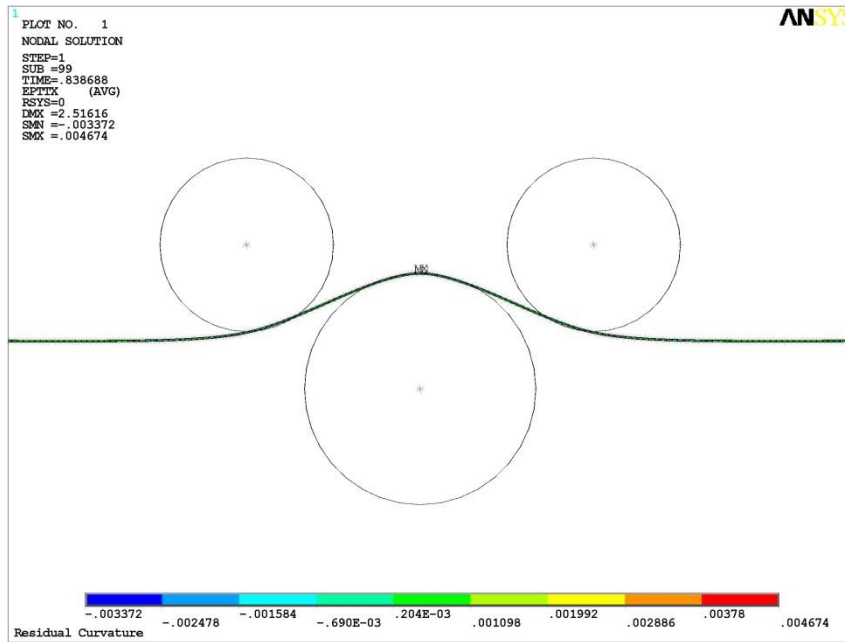

Figure 8-3: Results for equivalent total elasto-plastic strain

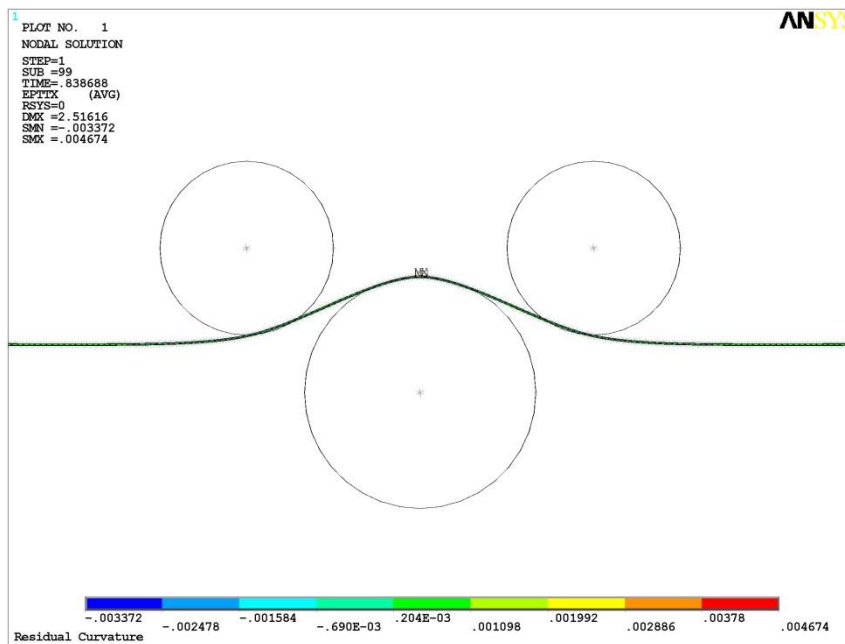

Figure 8-4: Results for lateral displacement

9. SUMMARY, CONCLUSIONS AND RECOMMENDATIONS

9.1 Summary

This chapter discusses and provides a brief summary of the results from the analyses and presents the conclusions of the work. The primary objective of the thesis has been to design the pipeline under controlled lateral buckling by applying the snake-lay and residual curvature lay combined with trawl interaction.

Firstly, snake-lay configurations without trawl interference were established based on the maximum allowable design feed-in in the buckle. The maximum allowable design feed-in was determined based on FE analyses performed by modelling local FE model of the selected pipeline with selected OOS snake radius. The basis for estimation of the maximum allowable design feed-in is the pipeline capacity which can be calculated based on the design criteria from DNV-OS-F101 and DNV-RP-110. In the current work, both load controlled and displacement controlled criteria has been considered.

Secondly, the similar analyses were performed for both snake-lay and residual curvature lay methods by combining the trawl interaction loads. Trawl pull-over loads were estimated based on the guidelines from DNV-RP-F11. The analyses were performed for the three types of trawl gear: Trawl board, Clump weight and Beam trawl.

All the analyses were performed using a general purpose finite element software ANSYS. The results based on both the analytical calculations and the FE analyses are presented.

9.2 Conclusions

Based on the results from analyses, the following conclusions are made for snake and residual curvature methods.

9.2.1 Snake-lay

- The 22'' pipeline considered in the present work was predicted to lateral buckling based on the screening check for the critical buckling force. It is required to mitigate and control lateral buckling.
- The allowable design feed-in value estimated based on the load controlled criterion is approximately 0.9m, whereas the value estimated based on the displacement

controlled criterion is approximately 1.43m. Therefore, it is conservative to design the pipeline against the load controlled criterion.

- The load controlled criteria resulted in nine snakes. Whereas, the longer allowable feed-in lengths based on the strain based criterion (DCC) minimized the number of snakes from nine to seven.
- For the snake-lay without trawl interaction, no intermittent rock dumping is required against both the criteria. But, the rock dumping towards both the pipeline ends is required to minimize the pipeline expansion to be with the assumed design expansion of connecting spools.
- Number of snake curves in the lay configuration depends on allowable feed-in to the buckle and on critical buckling force for the given configuration. Longer buckle feed-in lengths may allow increasing the distance between the buckles and reducing number of snake curves in the lay configuration and further facilitate to reduce rock dumping requirements if intermittent rock is required. This reflects the saving in cost for installation and construction.
- The allowable feed-in got reduced significantly when there is a trawl interaction as the pipeline has already undergoes a certain lateral displacement before it is exposed to the operational loads. This resulted in increased number snakes and intermittent rock dumping.
- Sensitivity analyses with respect to the angle of attack (hit) and soil friction coefficients were performed to determine the worst scenario for the trawl pull-over loads. It can be concluded from the results that the worst scenario is when the angle of attack is 90 degrees.

9.2.2 Residual Curvature Lay

- The 14'' pipeline considered in the residual curvature lay is susceptible to lateral buckling based on the screening check for the critical buckling force. Also for this line, it is required to mitigate and control lateral buckling.
- The allowable design feed-in value estimated based on the load controlled criterion is approximately 0.64m based on best estimate soil friction. To reduce the over conservatism this value is used for lateral buckling design.

9.3 Recommendation for Further Work

In this thesis work, snake-lay and residual curvature lay configuration as buckle mitigating and triggering technique was discussed. This thesis recommends the following suggestions and recommendations for further work:

- Comprehensive comparison between controlled lateral buckling design methods, as in this thesis work snake-lay mitigation and residual curvature lay methods of lateral buckling and other lateral mitigation methods and burying pipeline shall be conducted to find out which one is the cost effective solution.
- Seabed unevenness may influence size of imperfections and shall be covered in the pipeline design by analyses.
- A whole pipeline system should be analyzed based on as laid seabed profile for the confirmation of buckle initiation.

REFERENCES

- ANSYS, 2009. *Theory Reference for the Mechanical APDL and Mechanical Applications*. Canonsburg: ANSYS.
- Bai, Y. & Bai, Q., 2005. *Subsea Pipelines and Risers*. First ed. Kidlington, Oxford: Elsevier.
- Braestrup, M., 2005. *Design and Installation of Marine Pipelines*. First ed. Oxford: Blackwell Science.
- Carr, M., Bruton, D. & Baxter, D., 2011. *Safe Design of Pipelines with Lateral Buckling*.:SAFEBUCK JIP.
- DNV, 2007. *Global buckling of Submarine pipeline: DNV-RP-F110*. Høvik: Det Norske Veritas.
- DNV, 2010. *Interference between Trawl Gear and Pipelines: DNV-RP-F111*. Høvik: Det Norske Veritas.
- DNV, 2013. *Submarine Pipeline Systems: DNV-OS-F101*. Høvik: Det Norske Veritas.
- Einsfeld, R. & Murray, D. W., 1984. Buckling Analysis of high temperature pressurized pipelines with soil-structure interaction. *Journal of the Brazilian Society of Mechanical Sciences and Engineering*, 110(2).
- Endal, G., 2005. *Method for Pipelaying from a Coil to the Sea Bed, Controlling Thermal Expansion*. USA, Patent No. US 6910830 B2.
- Harrison, G. E., Brunner, M. & Bruton, D., 2003. *King Flowlines- Thermal Expansion Design and Implementation*. Houston: Offshore Technology Conference (OTC).
- Hobbs, R. E., 1984. 'In service buckling of heated pipelines'. *Journal of Transportation Engineering*, 110(2), pp. 175-189.
- Jee, 2006. *Offshore Pipeline Construction*. First red. Tonbridge, Kent: Jee.
- Jee, 2013. *Subsea pipeline design*. First ed. Tonbridge, Kent: Jee.
- Karunakaran, D., 2013. *Pipeline and Riser Course*. Stavanger: University of Stavanger.
- Kaye, D. & Plamer, A., 1996. *Lateral Buckling of Subsea Pipelines: Comparison Between Design and Operations*. Aberdeen, UK: The Society for Under Water Technology.
- Kien, L. K., Ming, S. & Maschner, E., *Design of High temperature/High Pressure (HT/HP) pipeline against Lateral Buckling*, Kuala Lumpur, Malaysia: J P Kenny.

REFERENCES

Kyriakides, S. & Corona, E., 2007. *Mechanics Of Offshore Pipelines: Buckling and Collapse, Vol. 1*. First ed. Oxford: Elsevier BV.

Palmer, A. C. & Ling, M. T., 1981. *Movement of Submarine pipelines close to platforms (OTC4067)*. Houston, Texas, Offshore Technology Conference (OTC).

Palmer, A. & King, R. A., 2004. *Subsea pipeline Engineering*. first red. Tulsa, Oklahoma, USA: Pennwell Corporation.

Subsea7, 2012. *Subsea7's Seven Navica Brochure*. [Internett]

Available at:

<http://www.subsea7.com/content/dam/subsea7/documents/whatwedo/fleet/rigidpipelay/SevenNavica.pdf>

APPENDIX

APPENDIX A

Calculation of Anchor points and other preparation works

Description :

This MathCAD sheet is for determining the virtual anchor points for a short pipeline and temperature profile for the

short pipeline. There exists some preparation works like calculating fully constrained effective axial force and effective axial force due to friction of a rigid pipeline under operational condition. The analytical results are compared with the

non-linear using a soft ware.

Units : MPa = $1\text{N}\cdot\text{mm}^{-2}$ and $g = 9.81\cdot\text{m}\cdot\text{s}^{-2}$

Water depth

WD := 800m

Pipeline Data :

Pipeline Outside Diameter

OD := 559mm

Wall Thickness

tkwall := 19.1mm

External Coating Thickness

t_ext := 5mm

Concrete Coating Thickness

t_conc := 55mm

Length of pipeline

L := 2000m

Material Properties :

Pipeline :

Pipe Steel Density

DENS := $7850\cdot\text{kg}\cdot\text{m}^{-3}$

SMYS Steel Pipe

SMYS := 450MPa

Steel Pipe Young's Modulus

E := 207000MPa

Steel Pipe Thermal Expansion Coeff.

$\alpha := 1.17\cdot 10^{-5}\cdot\text{C}^{-1}$

Steel Poisson Ratio

$\nu := 0.3$

Insulation or Coating :

Insulation or Coating Density

P_EXT := $910\cdot\text{kg}\cdot\text{m}^{-3}$

Concrete Coating Density

P_CONC := $2400\cdot\text{kg}\cdot\text{m}^{-3}$

Operating Parameters :

Sea Water Density

RHO_W := $1025\cdot\text{kg}\cdot\text{m}^{-3}$

Max Content Density

DENSFL := $900\cdot\text{kg}\cdot\text{m}^{-3}$

Design Pressure

Pres_d := 15MPa

Operating Pressure

Pres_op := 15MPa

Hydrotest Pressure

Pres_hyd := 0MPa

Ambient Temperature

T_amb := 5·C

Operating Temperature

T_op := 95·C

EXTERNAL LOADS :

Bending moment	$M_b := 0\text{kN}\cdot\text{m}$
Axial Force	$N_a := 0\text{kN}$
Residual Lay Tension	$N_{lay} := 0\text{kN}$

SOIL PROPERTIES :

Axial Friction Factor	$\mu_{axial} := 0.7$
Lateral Friction Factor	$\mu_{lateral} := 1.0$

SAFETY FACTORS :

Usage Factor for Hoop Stress	$\beta_h := 0.72$
Usage Factor for Longitudinal Stress	$\beta_l := 0.8$
Usage Factor for Longitudinal Stress	$\beta_c := 0.9$

PARAMETER CALCULATION :

Effective Pipe Diameter	$D_{EFF} := OD + 2 \cdot (t_{ext} + t_{conc})$	
Internal Diameter	$ID := OD - 2 \cdot t_{kwall}$	
Cross-sectional Area of steel pipe	$AS := \frac{\pi}{4} \cdot (OD^2 - ID^2)$	
Cross-sectional Area of External Coat.	$AS_{EXT} := \frac{\pi}{4} \cdot [(OD + 2 \cdot t_{ext})^2 - OD^2]$	
Cross-sectional Area of Concrete Coat.	$AS_{CONC} := \frac{\pi}{4} \cdot [(OD + 2 \cdot t_{ext} + 2 \cdot t_{conc})^2 - (OD + 2 \cdot t_{ext})^2]$	
Pipe Steel Mass	$M_{STEEL} := AS \cdot DENS$	
External Coating Mass	$M_{EXT} := AS_{EXT} \cdot P_{EXT}$	
Concrete Coating Mass	$M_{CONC} := AS_{CONC} \cdot P_{CONC}$	
Content Mass	$M_{CONT} := \left(\frac{\pi}{4} \cdot ID^2\right) \cdot DENS_{FL}$	
Water Content Mass	$M_{WATER} := \left(\frac{\pi}{4} \cdot ID^2\right) \cdot RHO_W$	
Bouyancy Mass	$M_{BUOY} := \left(\frac{\pi}{4} \cdot D_{EFF}^2\right) \cdot RHO_W$	
Pipeline Total Mass (Weight in Air)	$M_{WALL} := M_{STEEL} + M_{EXT} + M_{CONC} + M_{CONT}$	
Submerged Mass (weight in Water)	$M_{SUB} := M_{WALL} - M_{BUOY}$	
Steel Pipe Dry Weight	$W_{dry} := M_{WALL} \cdot g$	$W_{dry} = 6993.189 \cdot \text{N} \cdot \text{m}^{-1}$
Content Weight	$W_{CONT} := M_{CONT} \cdot g$	
Flooded Weight	$W_{WATER} := M_{WATER} \cdot g$	
Empty Pipe Submerged Weight	$W_{SUB} := M_{SUB} \cdot g$	$W_{SUB} = 3352.176 \cdot \text{N} \cdot \text{m}^{-1}$
Equivalent Density	$EQ_{DEN} := \frac{M_{WALL}}{AS}$	

Coating Equivalent Density (Insulation & Concrete Coating)	$DENSIN := \frac{t_{ext} \cdot P_{EXT} + t_{conc} \cdot P_{CONC}}{t_{ext} + t_{conc}}$
Coating Thickness (Insulation & Concrete Coating)	$TKIN := t_{ext} + t_{conc}$
coating Area (Insulation & Concrete Coating)	$AREAIN := AS_{EXT} + AS_{CONC}$
Moment Of Inertia of steel pipe cross section	$I_s := \frac{\pi}{64} \cdot (OD^4 - ID^4)$
Section Modulus of steel pipe	$Z_s := \frac{I_s}{\frac{OD}{2}}$
Temperature Difference	$\Delta T := (T_{op} - T_{amb})$

CALCULATION

HOOP STRESS

$$\sigma_h := [\text{Pres}_{op} - (\text{RHO}_W \cdot g \cdot \text{WD})] \cdot \frac{ID}{2 \cdot tk_{wall}}$$

LONGITUDINAL STRESS

End cap effect

$$\sigma_{lc} := \text{Pres}_{op} \cdot \frac{ID}{4 \cdot tk_{wall}}$$

Poisson effect

$$\sigma_{lh} := \nu \cdot \sigma_h \quad (\text{only for restrained pipeline})$$

Bending stress

$$\sigma_{lb} := \frac{M_b}{Z_r}$$

Axial Stress

$$\sigma_{la} := \frac{N_a}{AS}$$

Thermal stress

$$\sigma_{lt} := -\alpha \cdot E \cdot \Delta T \quad (\text{only for restrained pipeline})$$

Unrestrained Pipeline:

Total Longitudinal Stress

$$\sigma_{lu} := \sigma_{lc} + \sigma_{lb} + \sigma_{la}$$

Combined Stress
(Von Mises Stress Criteria)

$$\sigma_{von1} := \sqrt{\sigma_h^2 + \sigma_{lu}^2 - \sigma_h \cdot \sigma_{lu}} \quad \sigma_{von1} = 98.751 \cdot \text{MPa}$$

Total Strain

$$\epsilon_u := \alpha \cdot (T_{op} - T_{amb}) + \frac{\sigma_h}{2} \cdot \frac{1 - 2 \cdot \nu}{E} \quad \epsilon_u = 1.145 \times 10^{-3}$$

Restrained Pipeline:

Total longitudinal Stress

$$\sigma_{lr} := \sigma_{lh} + \sigma_{lb} + \sigma_{la} + \sigma_{lt}$$

Combined Stress
(Von Mises Stress Criteria)

$$\sigma_{von2} := \sqrt{\sigma_h^2 + \sigma_{lr}^2 - \sigma_h \cdot \sigma_{lr}} \quad \sigma_{von2} = 250.767 \cdot \text{MPa}$$

END EXPANSION :

Fully Constrained Axial Force $F_{\text{anchor}} := (\pi \cdot \text{ID} \cdot t_{\text{kwall}}) \cdot E \cdot \alpha \cdot \Delta T + \frac{\text{Pres_op} \cdot \pi \cdot \text{ID}^2}{4} \cdot (1 - 2 \cdot \nu)$ $F_{\text{anchor}} = 8.09 \times 10^3 \cdot \text{kN}$

Friction Force (Restraining Force) $f_{\text{fric}} := \mu_{\text{axial}} \cdot (W_{\text{SUB}})$ $f_{\text{fric}} = 2.347 \times 10^3 \cdot \frac{\text{N}}{\text{m}}$

Anchor Length $z := \frac{F_{\text{anchor}}}{f_{\text{fric}}}$ $z = 3.448 \cdot \text{km}$

$$z1 := \frac{\text{Pres_op} \cdot \pi \cdot \text{ID}^2}{4 \cdot f_{\text{fric}}} \left[\frac{4 \cdot t_{\text{kwall}} \cdot E \cdot \alpha \cdot \Delta T}{\text{Pres_op} \cdot \text{ID}} + (1 - 2 \cdot \nu) \right]$$

$z1 = 3.448 \cdot \text{km}$

Pipeline expansion $L_{\text{exp}} := \epsilon_u \cdot L$ $L_{\text{exp}} = 2.289 \text{ m}$

PLOT :

Input Temperature Profile

Number of Input Points $n := 15$ $i := 0..n - 1$
 KPStep := 10m

Number of Temperature Input Points
 Product Corresponding Temperature KP Point

$T_i :=$	$Kp_i :=$
95C	0·m
93.374C	200·m
91.777C	400·m
90.25C	600m
88.67C	800·m
87.911C	900·m
87.158C	1000·m
85.674C	1200·m
84.217C	1400·m
83.498C	1500·m
82.785C	1600·m
82.079C	1700m
81.38C	1800·m
80.687C	1900m
80C	2000m

Note : For non-linear temp. profiles use more input points. Linear temp. profiles only require inlet and outlet points.

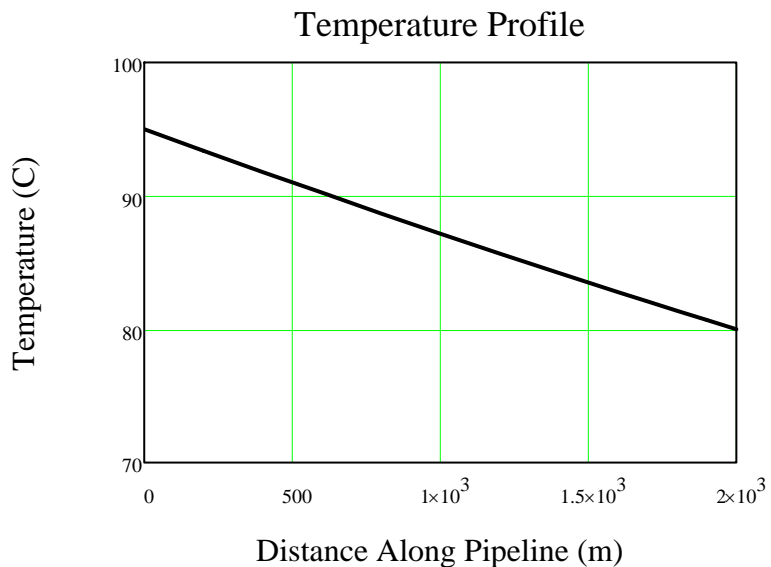

Input Water Depth Profile

Number of Input Points $nw := 2$
 $iw := 0..nw - 1$

Water Depth Corresponding KP point

$WD_{iw} :=$	$KP_{iw} :=$
100·m	0·m
100·m	2000·m

$WDw(x) := \text{linterp}(KPw, WDw, x)$

Effective Axial Force Derivation - Restrained Flowline

Define functions with KP:

$$x := KP_0, KP_{Step}.. KP_{n-1}$$

Define Temperature Difference with KP

$$\Delta T_i := T_i - T_{amb}$$

$$Temp(x) := \text{linterp}(KP, \Delta T, x)$$

Define External Pressure with KP

$$Po(x) := RHO_W \cdot g \cdot WDw(x)$$

Define Local Design Pressure with KP

$$Pin(x) := Pres_op + DENSFL \cdot g \cdot WDw(x)$$

Define Pressure Difference with KP

$$\Delta P(x) := Pin(x) - Po(x)$$

Thermal Expansion Force with KP

$$Ft(x) := -E \cdot AS \cdot \alpha \cdot Temp(x)$$

Poisons Force with KP

$$Fp(x) := \nu \cdot \Delta P(x) \cdot AS \cdot \frac{OD - tkwall}{2 \cdot tkwall}$$

Endcap Force with KP

$$Fe(x) := \frac{\pi}{4} \cdot (Pin(x) \cdot ID^2 - Po(x) \cdot OD^2)$$

Fully Restrained Axial Force with KP

$$Fr(x) := Nlay - Fe(x) + Fp(x) + Ft(x)$$

Plot of Fully Restrained Axial Force vs KP

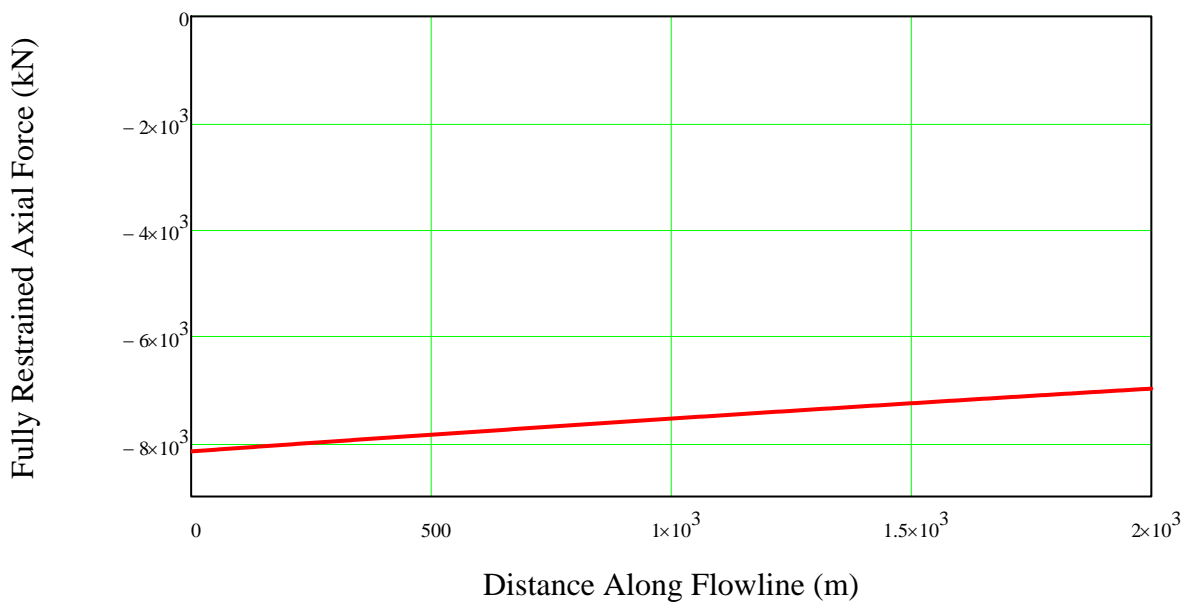

Effective Axial Force - Partially Restrained
Flowline

Flowline Length

$$L := K_{p_{n-1}} \quad L = 2 \cdot \text{km}$$

Maximum Friction Force
(at mid of pipeline)

$$P_{fmax} := \mu_{axial} \cdot (W_{SUB} + W_{CONT}) \cdot \frac{L}{2}$$

Friction Force with Length at Hot End

$$P_{fH}(x) := \mu_{axial} \cdot (W_{SUB} + W_{CONT}) \cdot x \cdot (-1)$$

Friction Force with Length at Cold End

$$P_{fC}(x) := \mu_{axial} \cdot (W_{SUB} + W_{CONT}) \cdot (x - L)$$

Logic Step to Calculate Friction Restraint Along Full
Length

$$P_{fmax} = 3663.085 \cdot \text{kN}$$

$$P_f(x) := \text{if}(P_{fH}(x) > P_{fC}(x), P_{fH}(x), P_{fC}(x))$$

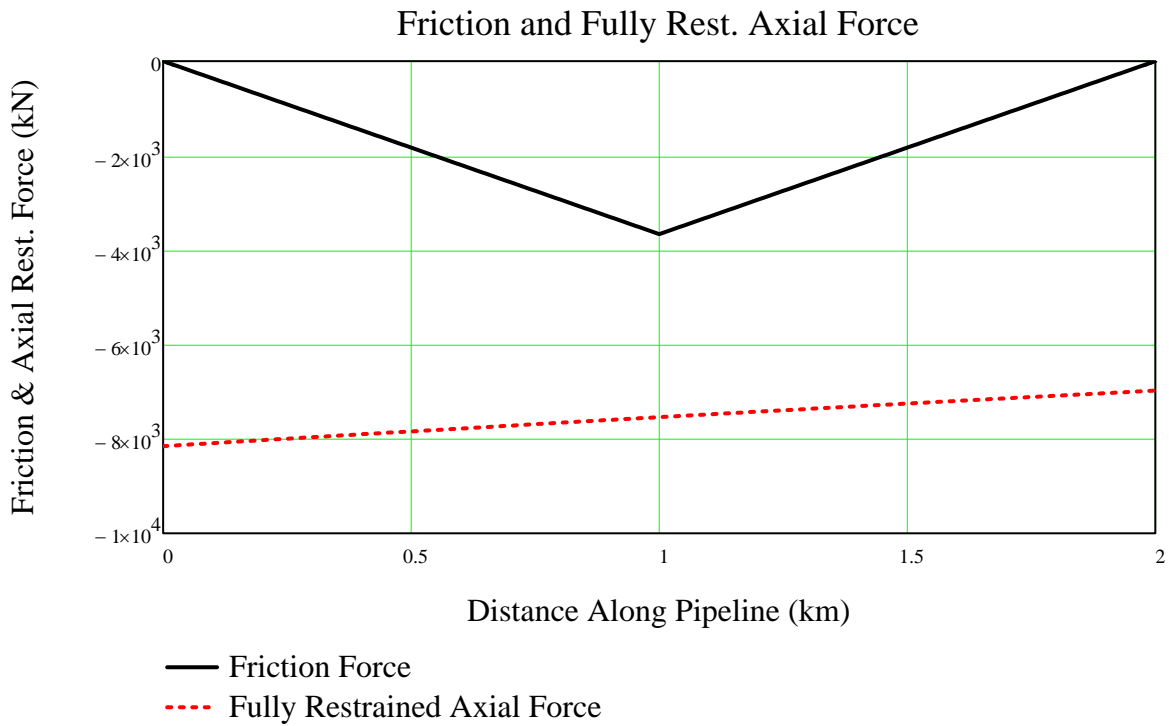

Logic statement to plot friction force if less than full restraint force i.e. effective axial force is the less of friction force or full restraint force.

Effective Axial Force

$$P_{eff}(x) := \text{if}(P_f(x) < F_r(x), F_r(x), P_f(x))$$

$$P_{buck}(x) := \text{if}(P_{eff}(x) < 0, P_{eff}(x), -10 \cdot N)$$

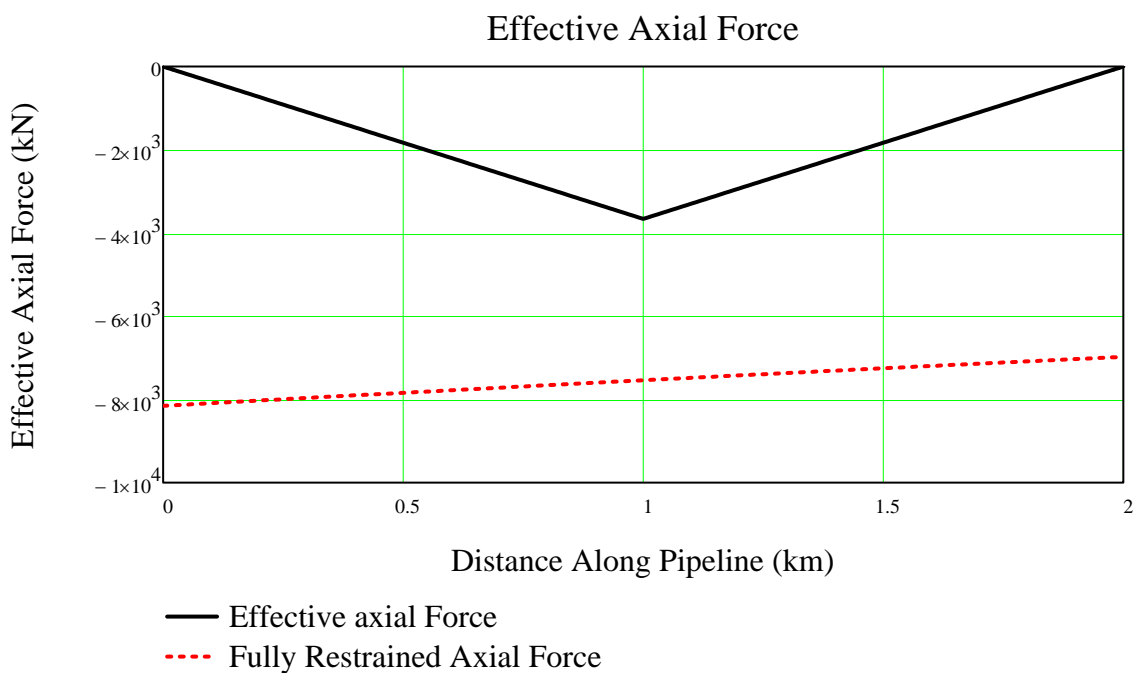

PLOT : Stress-Strain Curve

T := 0C, 1C.. 200C

$$\text{SMYS}(T) := \begin{cases} \text{SMYS} & \text{if } T \leq 50\text{C} \\ \text{SMYS} - \left[\left[\frac{3(T - 50\text{C})}{5} \right] \cdot \frac{\text{MPa}}{\text{C}} \right] & \text{if } 50\text{C} < T \leq 100\text{C} \\ \text{SMYS} - \left[\left[\frac{(T - 100\text{C})}{2.5} \right] \cdot \frac{\text{MPa}}{\text{C}} + 30\text{MPa} \right] & \text{otherwise} \end{cases}$$

De-rated Steel Yield Stress

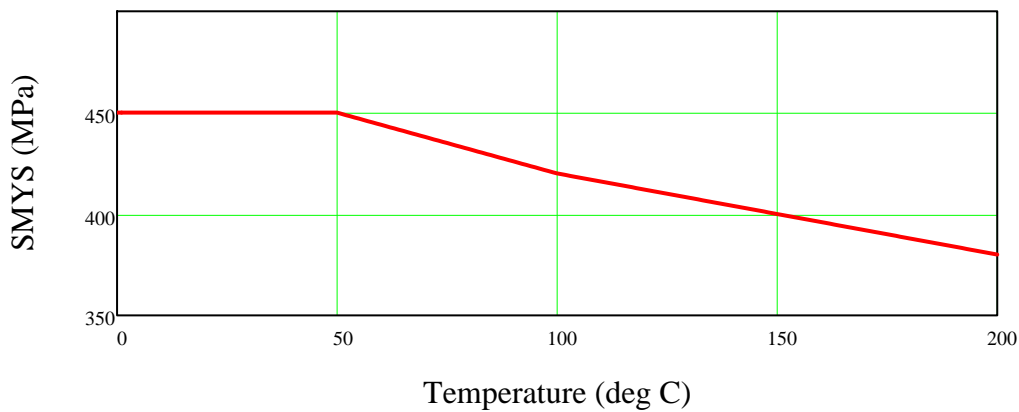

— De-rated Steel SMYS

$$\text{SMYS}(T_{\text{op}}) = 423 \cdot \text{MPa}$$

RESULT SUMMARY :PIPELINE PARAMETERS:

ID = 0.521 m

D_EFF = 0.679 m

TKIN = 60·mm

AS = 0.032·m²

AS_EXT = 8.859 × 10⁻³ m²

AS_CONC = 0.108 m²

AREAIN = 0.117 m²

M_STEEL = 254.312·kg·m⁻¹

M_EXT = 8.062·kg·m⁻¹

M_CONC = 258.767·kg·m⁻¹

M_CONT = 191.723·kg·m⁻¹

M_WATER = 218.351·kg·m⁻¹

M_BUOY = 371.153·kg·m⁻¹

MWALL = 712.863·kg·m⁻¹

M_SUB = 341.71·kg·m⁻¹

W_CONT = 1880.803·N·m⁻¹

W_WATER = 2142.026·N·m⁻¹

W_SUB = 3.352 × 10³·N·m⁻¹

APPENDIX

APPENDIX B

**Hobbs Lateral Buckling Forces:
Load Case with Lower Bound Lateral Friction Coefficient=0.6**

Limitations:

1. Consideration of concrete coating is NOT currently implemented in buckling calculations
2. Critical buckling array is for two pipe sizes only - with location fixed.
3. No consideration is given to lateral restraints other than seabed friction.

References:

1. Hobbs, R. E., '*In service buckling of heated pipelines*', Journal of transport engineering, Vol 110, No. 2, March 1984.
2. DNV-RP-F113 - Pipeline Subsea Repair, 2007

User Inputs

Yellow fields - user input

NOTE THAT FOR THE PURPOSES OF THE CALCULATIONS PRESENTED HEREIN, KP 0 HAS BEEN DEFINED AS BEING AT THE HOT END

Define KP for Variables

$KP := 2\text{km}$

*Pipeline length from HDD exit to offshore end
Offshore End at KP 34.16, HDD exit at KP 1.564*

Input KP Step size

$KPStep := 10\text{m}$

Define range of Kp variable

$x := 0, KPStep .. KP$

Define (x) in terms of xi
(counter)

$xi := 0, 1 .. \frac{KP}{KPStep}$

Pipeline Parameters

External Pipeline Diameter

$De := 559\text{mm}$

Wall Thickness

$$WT(x) := \begin{cases} 19.1\text{mm} & \text{if } x < 1\text{km} \\ 19.1\text{mm} & \text{if } x \geq 1\text{km} \end{cases}$$

Corrosion Allowance

$CA := 3\text{mm}$

(Corrosion Allowance is used in OSF101
Interaction ratio calculations only)

Young's Modulus of Pipe Material

$E := 207000 \cdot \text{MPa}$

Steel Density

$\rho_{st} := 7850 \cdot \text{kg} \cdot \text{m}^{-3}$

Specified Minimum Yield Strength

$SMYS := 450 \cdot \text{N} \cdot \text{mm}^{-2}$

$SMTS := 535\text{MPa}$

Coefficient of Thermal Expansion

$\alpha := 1.17 \cdot 10^{-5} \cdot \text{C}^{-1}$

Poisson's Ratio

$\nu := 0.3$

Coating Parameters

Corrosion Coating Density

$\rho_{cc} := 910 \cdot \text{kg} \cdot \text{m}^{-3}$

Corrosion Coating Thickness

$T_{cor} := 5 \cdot \text{mm}$

▼ Conc. Coat Parameters - NotUsed

Concrete Coating Density

$$\rho_{con} := 2400 \text{ kg} \cdot \text{m}^{-3}$$

Concrete Coating Thickness:

Number of sections for which concrete coating is defined:

$$n_c := 2$$

$$ic := 0 .. (n_c - 1)$$

KPconc_{ic} :=

0km
2km

Tconc_{ic} :=

55·mm
55mm

▲ Conc. Coat Parameters - NotUsed

Environmental Parameters

Density of Water

$$\rho_{water} := 1025 \cdot \text{kg} \cdot \text{m}^{-3}$$

Water Depth

$$n_w := 2$$

$$iw := 0 .. (n_w - 1)$$

Assume Linear depth variation - between HDD exit and well head

KPw_{iw} :=

0km
2km

WDw_{iw} :=

800m
800m

HDD exit

Installation Temperature

$$T_o := 5C$$

▼

Marine Growth (NOT USED)

$$T_{mar} := 0 \cdot \text{mm}$$

Marine Growth Density (NOT USED)

$$\rho_{mar} := 0 \cdot \text{kg} \cdot \text{m}^{-3}$$

▲

Axial Friction Factor - Use 0.2 for mudstone and 0.5 for sand (Ref 2, Table 4.1)

$$\mu(x) := \begin{cases} 0.35 & \text{if } x < 1\text{km} \\ 0.35 & \text{if } x \geq 1\text{km} \end{cases}$$

Lateral Friction Factor - Use 0.35 for mudstone and 0.6 for calcaranite/sand. (Ref 2, Table 4.1)

$$\mu_{lat}(x) := \begin{cases} 0.6 & \text{if } x < 1\text{km} \\ 0.6 & \text{if } x \geq 1\text{km} \end{cases}$$

Operational Parameters

Contents Density

$$\rho_{cont} := 900 \cdot \text{kg} \cdot \text{m}^{-3}$$

Internal Pressure

$$P_i := 15\text{MPa}$$

Lay Tension:

$$T_{lay} := 0\text{KN}$$

Calculations Section

▾ Define Functions for Variables

Concrete coating Thickness $T_{con}(x) := \text{linterp}(KP_{conc}, T_{conc}, x)$

Water Depth $WD(x) := \text{linterp}(KP_w, WD_w, x)$

Total Outside Diameter $Do(x) := De + 2 \cdot (T_{cor} + T_{con}(x) + T_{mar})$

Internal Diameter $Di(x) := De - 2 \cdot WT(x)$

Steel Area $A_{st}(x) := \frac{\pi}{4} \cdot (De^2 - Di(x)^2)$

Steel Mass $M_{st}(x) := A_{st}(x) \cdot \rho_{st}$

Corrosion Coating Area $A_{cc} := \frac{\pi}{4} \cdot [(De + 2 \cdot T_{cor})^2 - De^2]$

Corrosion Coating Mass $M_{cc} := A_{cc} \cdot \rho_{cc}$

Concrete Coating Area $A_{con}(x) := \frac{\pi}{4} \cdot [(De + 2 \cdot T_{cor} + 2 \cdot T_{con}(x))^2 - (De + 2 \cdot T_{cor})^2]$

Concrete Coating Mass $M_{con}(x) := A_{con}(x) \cdot \rho_{con}$

Mar.Growth Area $A_{mar}(x) := \frac{\pi}{4} \cdot [(De + 2 \cdot T_{cor} + 2 \cdot T_{con}(x) + 2 \cdot T_{mar})^2 - (De + 2 \cdot T_{con}(x) + 2 \cdot T_{cor})^2]$

Marine Growth Mass $M_{mar}(x) := A_{mar}(x) \cdot \rho_{mar}$

Contents Mass $M_{cont}(x) := \frac{\pi}{4} \cdot Di(x)^2 \cdot \rho_{cont}$

Buoyancy Force $F_b(x) := \frac{\pi}{4} \cdot Do(x)^2 \cdot \rho_{water} \cdot g$

Submerged Weight $W_s(x) := (M_{st}(x) + M_{cc} + M_{con}(x) + M_{cont}(x) + M_{mar}(x)) \cdot g - F_b(x)$

Second Moment of Area
of steel section $I(x) := \frac{\pi}{64} \cdot (De^4 - Di(x)^4)$

▴ Define Functions for Variables

Lateral Buckling assessment

Define Functions as per Ref [1]

Define Constants for lateral buckling modes (Ref 1 Table 1)

k :=

	0	1	2	3	4	5
0	"Mode"	"K1"	"K2"	"K3"	"K4"	"K5"
1	1	80.76	$6.39 \cdot 10^{-5}$	0.5	0	0.07
2	2	39.48	0	1	0.01	0.11
3	3	34.06	0	1.29	0.01	0.14
4	4	28.2	0	1.61	0.01	0.15
5	"inf"	39.48	$4.7 \cdot 10^{-5}$	$4.7 \cdot 10^{-5}$	0	0.05

k =

	0	1	2	3	4	5
0	"Mode"	"K1"	"K2"	"K3"	"K4"	"K5"
1	1	80.76	$6.391 \cdot 10^{-5}$	0.5	$2.407 \cdot 10^{-3}$	$6.938 \cdot 10^{-2}$
2	2	39.478	$1.743 \cdot 10^{-4}$	1	$5.532 \cdot 10^{-3}$	0.109
3	3	34.06	$1.668 \cdot 10^{-4}$	1.294	$1.032 \cdot 10^{-2}$	0.143
4	4	28.2	$2.144 \cdot 10^{-4}$	1.608	$1.047 \cdot 10^{-2}$	0.148
5	"inf"	39.478	$4.705 \cdot 10^{-5}$	$4.705 \cdot 10^{-5}$	$4.495 \cdot 10^{-3}$	$5.066 \cdot 10^{-2}$

Case 1 - Infinite mode lateral buckling

Buckle Wave Length $L_{\text{bar}}(x, \phi) := \left[\frac{2.7969 \cdot 10^5 \cdot (E \cdot I(x))^3}{(\phi \cdot W_s(x))^2 \cdot A_{\text{st}}(x) \cdot E} \right]^{0.125}$ Ref 1, Eq 22

Axial Force in Buckle $P_{\text{buck}}(x, L) := 4 \cdot \pi^2 \cdot \frac{E \cdot I(x)}{L^2}$ $L_{\text{bar}}(1\text{km}, \mu_{\text{lat}}(1\text{km})) = 59.211 \text{ m}$ Ref 1, Eq 20
 $W_s(20\text{km}) = 3.351 \cdot \frac{\text{kN}}{\text{m}}$

Axial force due to thermal expansion: $P_{\text{o_inf}}(x, L, \phi) := P_{\text{buck}}(x, L) + 4.7050 \cdot 10^{-5} \cdot A_{\text{st}}(x) \cdot E \cdot \left(\frac{\phi \cdot W_s(x)}{E \cdot I(x)} \right)^2 \cdot L^6$ Ref 1, Eq 21

Case 2 - All buckling modes

Arguments in the following functions are defined as follows:

- x - location of interest [m]
- L - Buckle Wave Length [m]
- modeb - buckling mode (1 to 4 for first four modes, 5 for infinite mode)
- f - Lateral Friction Factor
- P - Axial Force

Axial force in buckle $P_{\text{buck}}(x, L, \text{modeb}) := k_{\text{modeb}, 1} \cdot \frac{E \cdot I(x)}{L^2}$ Ref 1, Eq 26

Axial force due to thermal expansion:

Ref 1, Eq 27

$$P_o(x, L, \text{modeb}, \phi) := \begin{cases} P_{\text{buck}}(x, L, \text{modeb}) \dots & \text{if modeb} < 5 \\ + k_{\text{modeb}, 3} \cdot \phi \cdot W_s(x) \cdot L \cdot \left[1 + k_{\text{modeb}, 2} \cdot A_{\text{st}}(x) \cdot E \cdot \phi \cdot W_s(x) \cdot \frac{L^5}{(E \cdot I(x))^2} \right]^{0.5} - 1 & \\ P_{o_inf}(x, L, \phi) & \text{otherwise} \end{cases}$$

Maximum Buckle Amplitude: $y_{\text{max}}(x, L, \text{modeb}, \phi) := k_{\text{modeb}, 4} \cdot \phi \cdot \frac{W_s(x)}{E \cdot I(x)} \cdot L^4$ Ref 1, Eq 28

Maximum Bending Moment in Buckle: $M_{\text{max}}(x, L, \text{modeb}, \phi) := k_{\text{modeb}, 5} \cdot \phi \cdot W_s(x) \cdot L^2$ Ref 1, Eq 29

Maximum Slope: $y_{\text{maxbar}}(x, L, \phi) := 0.01267 \cdot \left(\phi \cdot \frac{W_s(x)}{E \cdot I(x)} \cdot L^3 \right)$ Ref 1, Eq 25

Define a function, which for a given mode, location and friction factor, returns an array with the following format:

- Col 1 - Buckle Length
- Col 2 - Required axial force to cause buckle with length in column 1

Note that for data processing purposes, all outputs are nondimensionalised within this routine (In MATHCAD all elements of an array must have the same or no units).

$$\text{buck_array}(x, \text{modeb}, \phi) := \begin{cases} LL \leftarrow L_{\text{bar}}(x, \phi) \\ n_{\text{test}} \leftarrow 500 \\ \text{for } i \in 0 \dots n_{\text{test}} \\ \quad \text{mult} \leftarrow i \cdot \frac{20}{n_{\text{test}}} + 0.05 \\ \quad L_{\text{test}} \leftarrow LL \cdot \text{mult} \\ \quad PP \leftarrow P_o(x, L_{\text{test}}, \text{modeb}, \phi) \\ \quad \Delta T \leftarrow \left(E \cdot A_{\text{st}}(x) \cdot \frac{\alpha}{PP} \right)^{-1} \\ \quad \text{out}_{i,0} \leftarrow \frac{L_{\text{test}}}{m} \\ \quad \text{out}_{i,1} \leftarrow \frac{PP}{(\text{kg m sec}^{-2}) \cdot 1000} \end{cases}$$

out

Define a routine that, given a matrix of Buckle length vs. Axial force, will calculate the minimum axial force to instigate a buckle at a given mode. Output is a vector with the following values:

- 0 - Critical Buckle Length
- 1 - Critical Temperature for buckle (assuming fixed pipeline)
- 2 - Critical buckling load

```
T_P_crit(x, modeb,  $\phi$ ) :=
  L_array ← buck_array(x, modeb,  $\phi$ )(0)
  P_array ← buck_array(x, modeb,  $\phi$ )(1)
  P_crit ← min(P_array)
  L_crit_index ← match(P_crit, P_array)0
  L_crit ← L_arrayL_crit_index
  out0 ← L_crit
  out1 ← P_crit
  out
```

```
test_data_a := buck_array(1000m, 1,  $\mu_{lat}(1000m)$ )
test_data_b := buck_array(1000m, 2,  $\mu_{lat}(1000m)$ )
test_data_c := buck_array(1000m, 3,  $\mu_{lat}(1000m)$ )
test_data_d := buck_array(1000m, 4,  $\mu_{lat}(1000m)$ )
test_data_e := buck_array(1000m, 5,  $\mu_{lat}(1000m)$ )
```

Define Functions as per Ref [1]

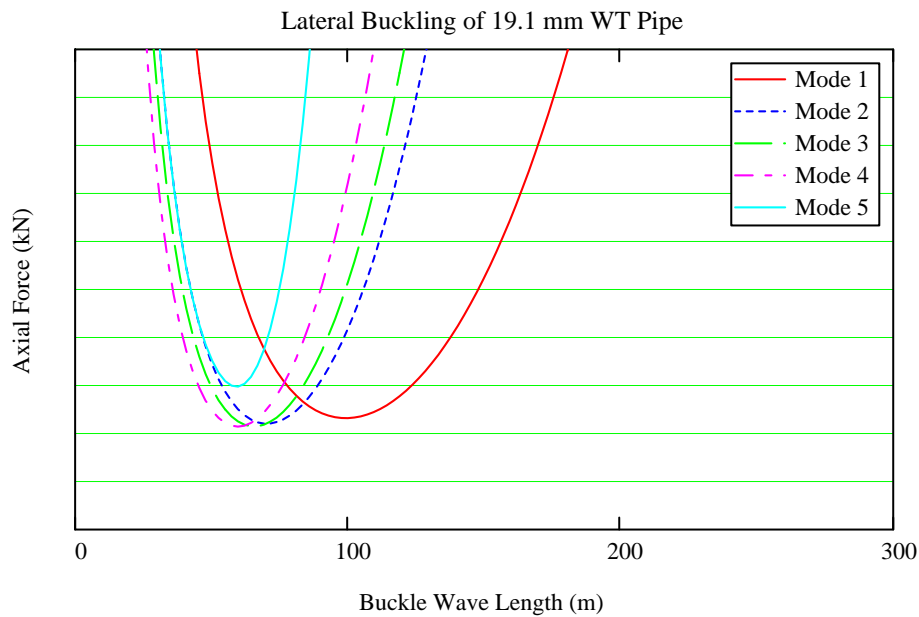

Calculate Critical buckling temperature and axial force for the specified lateral friction coefficient and a range of modes (The critical buckling temperature is changes only with pipe wall thickness and Friction factor):

$$aa := \min[(test_data_a)^{\langle 1 \rangle}] \quad aa = 3085.809$$

$$bb := \min(test_data_b^{\langle 1 \rangle}) \quad bb = 2984.454$$

$$cc := \min(test_data_c^{\langle 1 \rangle}) \quad cc = 2934.649$$

$$dd := \min(test_data_d^{\langle 1 \rangle}) \quad dd = 2926.725$$

$$ee := \min(test_data_e^{\langle 1 \rangle}) \quad ee = 3675.432$$

$$MinBuckleForce := \min[(test_data_a)^{\langle 1 \rangle}, (test_data_b)^{\langle 1 \rangle}, (test_data_c)^{\langle 1 \rangle}, (test_data_d)^{\langle 1 \rangle}, (test_data_e)^{\langle 1 \rangle}]$$

$$MinBuckleForce = 2926.725$$

**Hobbs Lateral Buckling Forces:
Load Case with Best Estimate Lateral Friction Coefficient=0.8**

Limitations:

1. Consideration of concrete coating is NOT currently implemented in buckling calculations
2. Critical buckling array is for two pipe sizes only - with location fixed.
3. No consideration is given to lateral restraints other than seabed friction.

References:

1. Hobbs, R. E., '*In service buckling of heated pipelines*', Journal of transport engineering, Vol 110, No. 2, March 1984.
2. DNV-RP-F113 - Pipeline Subsea Repair, 2007

Load Case: Best Estimate lateral Soil Friction Coefficient=0.8

User Inputs

Yellow fields - user input

NOTE THAT FOR THE PURPOSES OF THE CALCULATIONS PRESENTED HEREIN, KP 0 HAS BEEN DEFINED AS BEING AT THE HOT END

Define KP for Variables $KP := 2\text{km}$ *Pipeline length from HDD exit to offshore end
Offshore End at KP 34.16, HDD exit at KP 1.564*

Input KP Step size $KPStep := 10\text{m}$

Define range of Kp variable $x := 0, KPStep .. KP$

Define (x) in terms of xi
(counter) $xi := 0, 1 .. \frac{KP}{KPStep}$

Pipeline Parameters

External Pipeline Diameter $De := 559\text{mm}$

Wall Thickness

$$WT(x) := \begin{cases} 19.1\text{mm} & \text{if } x < 1\text{km} \\ 19.1\text{mm} & \text{if } x \geq 1\text{km} \end{cases}$$

Corrosion Allowance $CA := 3\text{mm}$

(Corrosion Allowance is used in OSF101
Interaction ratio calculations only)

Young's Modulus of Pipe Material $E := 207000 \cdot \text{MPa}$

Steel Density $\rho_{st} := 7850 \cdot \text{kg} \cdot \text{m}^{-3}$

Specified Minimum Yield Strength $SMYS := 450 \cdot \text{N} \cdot \text{mm}^{-2}$

$SMTS := 535\text{MPa}$

Coefficient of Thermal Expansion $\alpha := 1.17 \cdot 10^{-5} \cdot \text{C}^{-1}$

Poisson's Ratio $\nu := 0.3$

Coating Parameters

Corrosion Coating Density $\rho_{cc} := 910 \cdot \text{kg} \cdot \text{m}^{-3}$

Corrosion Coating Thickness $T_{cor} := 5 \cdot \text{mm}$

Conc. Coat Parameters - NotUsed

Concrete Coating Density

$$\rho_{\text{con}} := 2400 \text{ kg} \cdot \text{m}^{-3}$$

Concrete Coating Thickness:

Number of sections for which concrete coating is defined:

$$n_c := 2$$

$$i_c := 0 .. (n_c - 1)$$

$$KP_{\text{conc}, i_c} :=$$

0km
2km

$$T_{\text{conc}, i_c} :=$$

55mm
55mm

 Conc. Coat Parameters - NotUsed
Environmental Parameters

Density of Water

$$\rho_{\text{water}} := 1025 \cdot \text{kg} \cdot \text{m}^{-3}$$

Water Depth

$$n_w := 2$$

Assume Linear depth variation - between HDD exit and well head

$$i_w := 0 .. (n_w - 1)$$

$$KP_{w, i_w} :=$$

0km
2km

$$WD_{w, i_w} :=$$

800m
800m

HDD exit

Installation Temperature

$$T_o := 5\text{C}$$



Marine Growth (NOT USED)

$$T_{\text{mar}} := 0 \cdot \text{mm}$$

Marine Growth Density (NOT USED)

$$\rho_{\text{mar}} := 0 \cdot \text{kg} \cdot \text{m}^{-3}$$



Axial Friction Factor - Use 0.2 for mudstone and 0.5 for sand (Ref 2, Table 4.1)

$$\mu(x) := \begin{cases} 0.35 & \text{if } x < 1\text{km} \\ 0.35 & \text{if } x \geq 1\text{km} \end{cases}$$

Lateral Friction Factor - Use 0.35 for mudstone and 0.6 for calcaranite/sand. (Ref 2, Table 4.1)

$$\mu_{\text{lat}}(x) := \begin{cases} 0.8 & \text{if } x < 1\text{km} \\ 0.8 & \text{if } x \geq 1\text{km} \end{cases}$$

Operational Parameters

Contents Density

$$\rho_{\text{cont}} := 900 \cdot \text{kg} \cdot \text{m}^{-3}$$

Internal Pressure

$$P_i := 15\text{MPa}$$

Lay Tension:

$$T_{\text{lay}} := 0\text{KN}$$

Calculations Section
 Define Functions for Variables

Concrete coating Thickness $T_{con}(x) := \text{linterp}(KP_{conc}, T_{conc}, x)$

Water Depth $WD(x) := \text{linterp}(KP_w, WD_w, x)$

Total Outside Diameter $Do(x) := De + 2 \cdot (T_{cor} + T_{con}(x) + T_{mar})$

Internal Diameter $Di(x) := De - 2 \cdot WT(x)$

Steel Area $A_{st}(x) := \frac{\pi}{4} \cdot (De^2 - Di(x)^2)$

Steel Mass $M_{st}(x) := A_{st}(x) \cdot \rho_{st}$

Corrosion Coating Area $A_{cc} := \frac{\pi}{4} \cdot [(De + 2 \cdot T_{cor})^2 - De^2]$

Corrosion Coating Mass $M_{cc} := A_{cc} \cdot \rho_{cc}$

Concrete Coating Area $A_{con}(x) := \frac{\pi}{4} \cdot [(De + 2 \cdot T_{cor} + 2 \cdot T_{con}(x))^2 - (De + 2 \cdot T_{cor})^2]$

Concrete Coating Mass $M_{con}(x) := A_{con}(x) \cdot \rho_{con}$

Mar.Growth Area $A_{mar}(x) := \frac{\pi}{4} \cdot [(De + 2 \cdot T_{cor} + 2 \cdot T_{con}(x) + 2 \cdot T_{mar})^2 - (De + 2 \cdot T_{con}(x) + 2 \cdot T_{cor})^2]$

Marine Growth Mass $M_{mar}(x) := A_{mar}(x) \cdot \rho_{mar}$

Contents Mass $M_{cont}(x) := \frac{\pi}{4} \cdot Di(x)^2 \cdot \rho_{cont}$

Buoyancy Force $F_b(x) := \frac{\pi}{4} \cdot Do(x)^2 \cdot \rho_{water} \cdot g$

Submerged Weight $W_s(x) := (M_{st}(x) + M_{cc} + M_{con}(x) + M_{cont}(x) + M_{mar}(x)) \cdot g - F_b(x)$

Second Moment of Area of steel section $I(x) := \frac{\pi}{64} \cdot (De^4 - Di(x)^4)$

 Define Functions for Variables

Lateral Buckling assessment

Define Functions as per Ref [1]

Define Constants for lateral buckling modes (Ref 1 Table 1)

k :=

	0	1	2	3	4	5
0	"Mode"	"K1"	"K2"	"K3"	"K4"	"K5"
1	1	80.76	$6.39 \cdot 10^{-5}$	0.5	0	0.07
2	2	39.48	0	1	0.01	0.11
3	3	34.06	0	1.29	0.01	0.14
4	4	28.2	0	1.61	0.01	0.15
5	"inf"	39.48	$4.7 \cdot 10^{-5}$	$4.7 \cdot 10^{-5}$	0	0.05

k =

	0	1	2	3	4	5
0	"Mode"	"K1"	"K2"	"K3"	"K4"	"K5"
1	1	80.76	$6.391 \cdot 10^{-5}$	0.5	$2.407 \cdot 10^{-3}$	$6.938 \cdot 10^{-2}$
2	2	39.478	$1.743 \cdot 10^{-4}$	1	$5.532 \cdot 10^{-3}$	0.109
3	3	34.06	$1.668 \cdot 10^{-4}$	1.294	$1.032 \cdot 10^{-2}$	0.143
4	4	28.2	$2.144 \cdot 10^{-4}$	1.608	$1.047 \cdot 10^{-2}$	0.148
5	"inf"	39.478	$4.705 \cdot 10^{-5}$	$4.705 \cdot 10^{-5}$	$4.495 \cdot 10^{-3}$	$5.066 \cdot 10^{-2}$

Case 1 - Infinite mode lateral buckling

Buckle Wave Length $L_{bar}(x, \phi) := \left[\frac{2.7969 \cdot 10^5 \cdot (E \cdot I(x))^3}{(\phi \cdot W_s(x))^2 \cdot A_{st}(x) \cdot E} \right]^{0.125}$ Ref 1, Eq 22

Axial Force in Buckle $P_{buck}(x, L) := 4 \cdot \pi^2 \cdot \frac{E \cdot I(x)}{L^2}$ $L_{bar}(1\text{km}, \mu_{lat}(1\text{km})) = 55.102\text{ m}$ Ref 1, Eq 20
 $W_s(20\text{km}) = 3.351 \cdot \frac{\text{kN}}{\text{m}}$

Axial force due to thermal expansion: $P_{o_inf}(x, L, \phi) := P_{buck}(x, L) + 4.7050 \cdot 10^{-5} \cdot A_{st}(x) \cdot E \cdot \left(\frac{\phi \cdot W_s(x)}{E \cdot I(x)} \right)^2 \cdot L^6$ Ref 1, Eq 21

Case 2 - All buckling modes

Arguments in the following functions are defined as follows:

- x - location of interest [m]
- L - Buckle Wave Length [m]
- modeb - buckling mode (1 to 4 for first four modes, 5 for infinite mode)
- f - Lateral Friction Factor
- P - Axial Force

Axial force in buckle $P_{\text{buck}}(x, L, \text{modeb}) := k_{\text{modeb},1} \cdot \frac{E \cdot I(x)}{L^2}$ Ref 1, Eq 26

Axial force due to thermal expansion:

Ref 1, Eq 27

$$P_o(x, L, \text{modeb}, \phi) := \begin{cases} P_{\text{buck}}(x, L, \text{modeb}) \dots & \text{if modeb} < 5 \\ + k_{\text{modeb},3} \cdot \phi \cdot W_s(x) \cdot L \cdot \left[1 + k_{\text{modeb},2} \cdot \text{Ast}(x) \cdot E \cdot \phi \cdot W_s(x) \cdot \frac{L^5}{(E \cdot I(x))^2} \right]^{0.5} - 1 & \\ P_{o_inf}(x, L, \phi) & \text{otherwise} \end{cases}$$

Maximum Buckle Amplitude: $y_{\text{max}}(x, L, \text{modeb}, \phi) := k_{\text{modeb},4} \cdot \phi \cdot \frac{W_s(x)}{E \cdot I(x)} \cdot L^4$ Ref 1, Eq 28

Maximum Bending Moment in Buckle: $M_{\text{max}}(x, L, \text{modeb}, \phi) := k_{\text{modeb},5} \cdot \phi \cdot W_s(x) \cdot L^2$ Ref 1, Eq 29

Maximum Slope: $y_{\text{maxbar}}(x, L, \phi) := 0.01267 \cdot \left(\phi \cdot \frac{W_s(x)}{E \cdot I(x)} \cdot L^3 \right)$ Ref 1, Eq 25

Define a function, which for a given mode, location and friction factor, returns an array with the following format:

- Col 1 - Buckle Length
- Col 2 - Required axial force to cause buckle with length in column 1

Note that for data processing purposes, all outputs are nondimensionalised within this routine (In MATHCAD all elements of an array must have the same or no units).

$$\text{buck_array}(x, \text{modeb}, \phi) := \begin{cases} LL \leftarrow L_{\text{bar}}(x, \phi) \\ n_{\text{test}} \leftarrow 500 \\ \text{for } i \in 0 \dots n_{\text{test}} \\ \quad \text{mult} \leftarrow i \cdot \frac{20}{n_{\text{test}}} + 0.05 \\ \quad L_{\text{test}} \leftarrow LL \cdot \text{mult} \\ \quad PP \leftarrow P_o(x, L_{\text{test}}, \text{modeb}, \phi) \\ \quad \Delta T \leftarrow \left(E \cdot \text{Ast}(x) \cdot \frac{\alpha}{PP} \right)^{-1} \\ \quad \text{out}_{i,0} \leftarrow \frac{L_{\text{test}}}{m} \\ \quad \text{out}_{i,1} \leftarrow \frac{PP}{(\text{kg m sec}^{-2}) \cdot 1000} \end{cases}$$

out

Define a routine that, given a matrix of Buckle length vs. Axial force, will calculate the minimum axial force to instigate a buckle at a given mode. Output is a vector with the following values:

- 0 - Critical Buckle Length
- 1 - Critical Temperature for buckle (assuming fixed pipeline)
- 2 - Critical buckling load

```
T_P_crit(x, modeb,  $\phi$ ) :=
  L_array ← buck_array(x, modeb,  $\phi$ )(0)
  P_array ← buck_array(x, modeb,  $\phi$ )(1)
  P_crit ← min(P_array)
  L_crit_index ← match(P_crit, P_array)0
  L_crit ← L_arrayL_crit_index
  out_0 ← L_crit
  out_1 ← P_crit
  out
```

```
test_data_a := buck_array(1000m, 1,  $\mu_{lat}(1000m)$ )
test_data_b := buck_array(1000m, 2,  $\mu_{lat}(1000m)$ )
test_data_c := buck_array(1000m, 3,  $\mu_{lat}(1000m)$ )
test_data_d := buck_array(1000m, 4,  $\mu_{lat}(1000m)$ )
test_data_e := buck_array(1000m, 5,  $\mu_{lat}(1000m)$ )
```

Define Functions as per Ref [1]

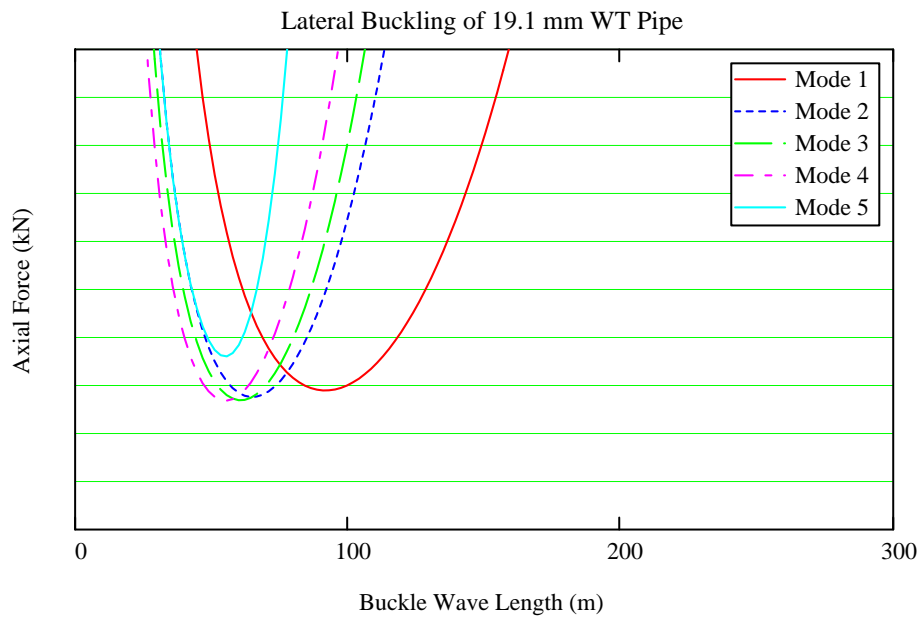

Calculate Critical buckling temperature and axial force for the specified lateral friction coefficient and a range of modes (The critical buckling temperature is changes only with pipe wall thickness and Friction factor):

$$aa := \min[(test_data_a)^{\langle 1 \rangle}] \quad aa = 3604.769$$

$$bb := \min(test_data_b^{\langle 1 \rangle}) \quad bb = 3481.919$$

$$cc := \min(test_data_c^{\langle 1 \rangle}) \quad cc = 3421.917$$

$$dd := \min(test_data_d^{\langle 1 \rangle}) \quad dd = 3414.596$$

$$ee := \min(test_data_e^{\langle 1 \rangle}) \quad ee = 4244.023$$

$$MinBuckleForce := \min[(test_data_a)^{\langle 1 \rangle}, (test_data_b)^{\langle 1 \rangle}, (test_data_c)^{\langle 1 \rangle}, (test_data_d)^{\langle 1 \rangle}, (test_data_e)^{\langle 1 \rangle}]$$

$$MinBuckleForce = 3414.596$$

Hobbs Lateral Buckling Forces:**Load Case with Upper Bound Lateral Friction Coefficient=1.0**

Limitations:

1. Consideration of concrete coating is NOT currently implemented in buckling calculations
2. Critical buckling array is for two pipe sizes only - with location fixed.
3. No consideration is given to lateral restraints other than seabed friction.

References:

1. Hobbs, R. E., '*In service buckling of heated pipelines*', Journal of transport engineering, Vol 110, No. 2, March 1984.
2. DNV-RP-F1113 - Pipeline Subsea Repair, 2007

Load Case: Upper Bound Lateral Friction Coefficient=1.0

User Inputs

Yellow fields - user input

NOTE THAT FOR THE PURPOSES OF THE CALCULATIONS PRESENTED HEREIN, KP 0 HAS BEEN DEFINED AS BEING AT THE HOT END

Define KP for Variables **KP := 2km** *Pipeline length from HDD exit to offshore end
Offshore End at KP 34.16, HDD exit at KP 1.564*

Input KP Step size **KPStep := 10m**

Define range of Kp variable $x := 0, KPStep .. KP$

Define (x) in terms of xi
(counter) $xi := 0, 1 .. \frac{KP}{KPStep}$

Pipeline Parameters

External Pipeline Diameter **De := 559mm**

Wall Thickness

WT(x) := $\begin{cases} 19.1\text{mm} & \text{if } x < 1\text{km} \\ 19.1\text{mm} & \text{if } x \geq 1\text{km} \end{cases}$

Corrosion Allowance **CA := 3mm**

(Corrosion Allowance is used in OSF101
Interaction ratio calculations only)

Young's Modulus of Pipe Material **E := 207000·MPa**

Steel Density **$\rho_{st} := 7850 \cdot \text{kg} \cdot \text{m}^{-3}$**

Specified Minimum Yield Strength **$SMYS := 450 \cdot \text{N} \cdot \text{mm}^{-2}$**

SMTS := 535MPa

Coefficient of Thermal Expansion **$\alpha := 1.17 \cdot 10^{-5} \cdot \text{C}^{-1}$**

Poisson's Ratio **$\nu := 0.3$**

Coating Parameters

Corrosion Coating Density **$\rho_{cc} := 910 \cdot \text{kg} \cdot \text{m}^{-3}$**

Corrosion Coating Thickness **Tcor := 5·mm**

▼ Conc. Coat Parameters - NotUsed

Concrete Coating Density

$$\rho_{con} := 2400 \text{ kg} \cdot \text{m}^{-3}$$

Concrete Coating Thickness:

Number of sections for which concrete coating is defined:

$$n_c := 2$$

$$i_c := 0 .. (n_c - 1)$$

KPconc_{i_c} :=

0km
2km

Tconc_{i_c} :=

55·mm
55mm

▲ Conc. Coat Parameters - NotUsed

Environmental Parameters

Density of Water

$$\rho_{water} := 1025 \cdot \text{kg} \cdot \text{m}^{-3}$$

Water Depth

$$n_w := 2$$

$$i_w := 0 .. (n_w - 1)$$

Assume Linear depth variation - between HDD exit and well head

KPw_{i_w} :=

0km
2km

WDw_{i_w} :=

800m
800m

HDD exit

Installation Temperature

$$T_o := 5C$$

▼

Marine Growth (NOT USED)

$$T_{mar} := 0 \cdot \text{mm}$$

Marine Growth Density (NOT USED)

$$\rho_{mar} := 0 \cdot \text{kg} \cdot \text{m}^{-3}$$

▲

Axial Friction Factor - Use 0.2 for mudstone and 0.5 for sand (Ref 2, Table 4.1)

$$\mu(x) := \begin{cases} 0.35 & \text{if } x < 1\text{km} \\ 0.35 & \text{if } x \geq 1\text{km} \end{cases}$$

Lateral Friction Factor - Use 0.35 for mudstone and 0.6 for calcaranite/sand. (Ref 2, Table 4.1)

$$\mu_{lat}(x) := \begin{cases} 0.8 & \text{if } x < 1\text{km} \\ 0.8 & \text{if } x \geq 1\text{km} \end{cases}$$

Operational Parameters

Contents Density

$$\rho_{cont} := 900 \cdot \text{kg} \cdot \text{m}^{-3}$$

Internal Pressure

$$P_i := 15\text{MPa}$$

Lay Tension:

$$T_{lay} := 0\text{KN}$$

Calculations Section
 Define Functions for Variables

Concrete coating Thickness $T_{con}(x) := \text{linterp}(KP_{conc}, T_{conc}, x)$

Water Depth $WD(x) := \text{linterp}(KP_w, WD_w, x)$

Total Outside Diameter $Do(x) := De + 2 \cdot (T_{cor} + T_{con}(x) + T_{mar})$

Internal Diameter $Di(x) := De - 2 \cdot WT(x)$

Steel Area $A_{st}(x) := \frac{\pi}{4} \cdot (De^2 - Di(x)^2)$

Steel Mass $M_{st}(x) := A_{st}(x) \cdot \rho_{st}$

Corrosion Coating Area $A_{cc} := \frac{\pi}{4} \cdot [(De + 2 \cdot T_{cor})^2 - De^2]$

Corrosion Coating Mass $M_{cc} := A_{cc} \cdot \rho_{cc}$

Concrete Coating Area $A_{con}(x) := \frac{\pi}{4} \cdot [(De + 2 \cdot T_{cor} + 2 \cdot T_{con}(x))^2 - (De + 2 \cdot T_{cor})^2]$

Concrete Coating Mass $M_{con}(x) := A_{con}(x) \cdot \rho_{con}$

Mar.Growth Area $A_{mar}(x) := \frac{\pi}{4} \cdot [(De + 2 \cdot T_{cor} + 2 \cdot T_{con}(x) + 2 \cdot T_{mar})^2 - (De + 2 \cdot T_{con}(x) + 2 \cdot T_{cor})^2]$

Marine Growth Mass $M_{mar}(x) := A_{mar}(x) \cdot \rho_{mar}$

Contents Mass $M_{cont}(x) := \frac{\pi}{4} \cdot Di(x)^2 \cdot \rho_{cont}$

Buoyancy Force $F_b(x) := \frac{\pi}{4} \cdot Do(x)^2 \cdot \rho_{water} \cdot g$

Submerged Weight $W_s(x) := (M_{st}(x) + M_{cc} + M_{con}(x) + M_{cont}(x) + M_{mar}(x)) \cdot g - F_b(x)$

Second Moment of Area of steel section $I(x) := \frac{\pi}{64} \cdot (De^4 - Di(x)^4)$

 Define Functions for Variables

Lateral Buckling assessment

Define Functions as per Ref [1]

Define Constants for lateral buckling modes (Ref 1 Table 1)

k :=

	0	1	2	3	4	5
0	"Mode"	"K1"	"K2"	"K3"	"K4"	"K5"
1	1	80.76	6.39·10 ⁻⁵	0.5	0	0.07
2	2	39.48	0	1	0.01	0.11
3	3	34.06	0	1.29	0.01	0.14
4	4	28.2	0	1.61	0.01	0.15
5	"inf"	39.48	4.7·10 ⁻⁵	4.7·10 ⁻⁵	0	0.05

k =

	0	1	2	3	4	5
0	"Mode"	"K1"	"K2"	"K3"	"K4"	"K5"
1	1	80.76	6.391·10 ⁻⁵	0.5	2.407·10 ⁻³	6.938·10 ⁻²
2	2	39.478	1.743·10 ⁻⁴	1	5.532·10 ⁻³	0.109
3	3	34.06	1.668·10 ⁻⁴	1.294	1.032·10 ⁻²	0.143
4	4	28.2	2.144·10 ⁻⁴	1.608	1.047·10 ⁻²	0.148
5	"inf"	39.478	4.705·10 ⁻⁵	4.705·10 ⁻⁵	4.495·10 ⁻³	5.066·10 ⁻²

Case 1 - Infinite mode lateral buckling

Buckle Wave Length $L_{bar}(x, \phi) := \left[\frac{2.7969 \cdot 10^5 \cdot (E \cdot I(x))^3}{(\phi \cdot W_s(x))^2 \cdot A_{st}(x) \cdot E} \right]^{0.125}$ Ref 1, Eq 22

Axial Force in Buckle $P_{buck}(x, L) := 4 \cdot \pi^2 \cdot \frac{E \cdot I(x)}{L^2}$ $L_{bar}(1km, \mu_{lat}(1km)) = 55.102m$ $W_s(20km) = 3.351 \cdot \frac{kN}{m}$ Ref 1, Eq 20

Axial force due to thermal expansion: $P_{o_inf}(x, L, \phi) := P_{buck}(x, L) + 4.7050 \cdot 10^{-5} \cdot A_{st}(x) \cdot E \cdot \left(\frac{\phi \cdot W_s(x)}{E \cdot I(x)} \right)^2 \cdot L^6$ Ref 1, Eq 21

Case 2 - All buckling modes

Arguments in the following functions are defined as follows:

- x - location of interest [m]
- L - Buckle Wave Length [m]
- modeb - buckling mode (1 to 4 for first four modes, 5 for infinite mode)
- f - Lateral Friction Factor
- P - Axial Force

Axial force in buckle $P_{buck}(x, L, modeb) := k_{modeb, 1} \cdot \frac{E \cdot I(x)}{L^2}$ Ref 1, Eq 26

Axial force due to thermal expansion:

Ref 1, Eq 27

$$P_o(x, L, \text{modeb}, \phi) := \begin{cases} P_{\text{buck}}(x, L, \text{modeb}) \dots & \text{if modeb} < 5 \\ + k_{\text{modeb},3} \cdot \phi \cdot W_s(x) \cdot L \cdot \left[1 + k_{\text{modeb},2} \cdot \text{Ast}(x) \cdot E \cdot \phi \cdot W_s(x) \cdot \frac{L^5}{(E \cdot I(x))^2} \right]^{0.5} - 1 & \\ P_{o_inf}(x, L, \phi) & \text{otherwise} \end{cases}$$

Maximum Buckle Amplitude: $y_{\text{max}}(x, L, \text{modeb}, \phi) := k_{\text{modeb},4} \cdot \phi \cdot \frac{W_s(x)}{E \cdot I(x)} \cdot L^4$ Ref 1, Eq 28

Maximum Bending Moment in Buckle: $M_{\text{max}}(x, L, \text{modeb}, \phi) := k_{\text{modeb},5} \cdot \phi \cdot W_s(x) \cdot L^2$ Ref 1, Eq 29

Maximum Slope: $y_{\text{maxbar}}(x, L, \phi) := 0.01267 \cdot \left(\phi \cdot \frac{W_s(x)}{E \cdot I(x)} \cdot L^3 \right)$ Ref 1, Eq 25

Define a function, which for a given mode, location and friction factor, returns an array with the following format:

- Col 1 - Buckle Length
- Col 2 - Required axial force to cause buckle with length in column 1

Note that for data processing purposes, all outputs are nondimensionalised within this routine (In MATHCAD all elements of an array must have the same or no units).

$$\text{buck_array}(x, \text{modeb}, \phi) := \begin{cases} LL \leftarrow L_{\text{bar}}(x, \phi) \\ n_{\text{test}} \leftarrow 500 \\ \text{for } i \in 0..n_{\text{test}} \\ \quad \text{mult} \leftarrow i \cdot \frac{20}{n_{\text{test}}} + 0.05 \\ \quad L_{\text{test}} \leftarrow LL \cdot \text{mult} \\ \quad PP \leftarrow P_o(x, L_{\text{test}}, \text{modeb}, \phi) \\ \quad \Delta T \leftarrow \left(E \cdot \text{Ast}(x) \cdot \frac{\alpha}{PP} \right)^{-1} \\ \quad \text{out}_{i,0} \leftarrow \frac{L_{\text{test}}}{m} \\ \quad \text{out}_{i,1} \leftarrow \frac{PP}{(\text{kg m sec}^{-2}) \cdot 1000} \end{cases}$$

out

Define a routine that, given a matrix of Buckle length vs. Axial force, will calculate the minimum axial force to instigate a buckle at a given mode. Output is a vector with the following values:

- 0 - Critical Buckle Length
- 1 - Critical Temperature for buckle (assuming fixed pipeline)
- 2 - Critical buckling load

```
T_P_crit(x, modeb, φ) :=
  L_array ← buck_array(x, modeb, φ)⟨0⟩
  P_array ← buck_array(x, modeb, φ)⟨1⟩
  P_crit ← min(P_array)
  L_crit_index ← match(P_crit, P_array)0
  L_crit ← L_array_L_crit_index
  out_0 ← L_crit
  out_1 ← P_crit
  out
```

```
test_data_a := buck_array(1000m, 1, μ_lat(1000m))
test_data_b := buck_array(1000m, 2, μ_lat(1000m))
test_data_c := buck_array(1000m, 3, μ_lat(1000m))
test_data_d := buck_array(1000m, 4, μ_lat(1000m))
test_data_e := buck_array(1000m, 5, μ_lat(1000m))
```

Define Functions as per Ref [1]

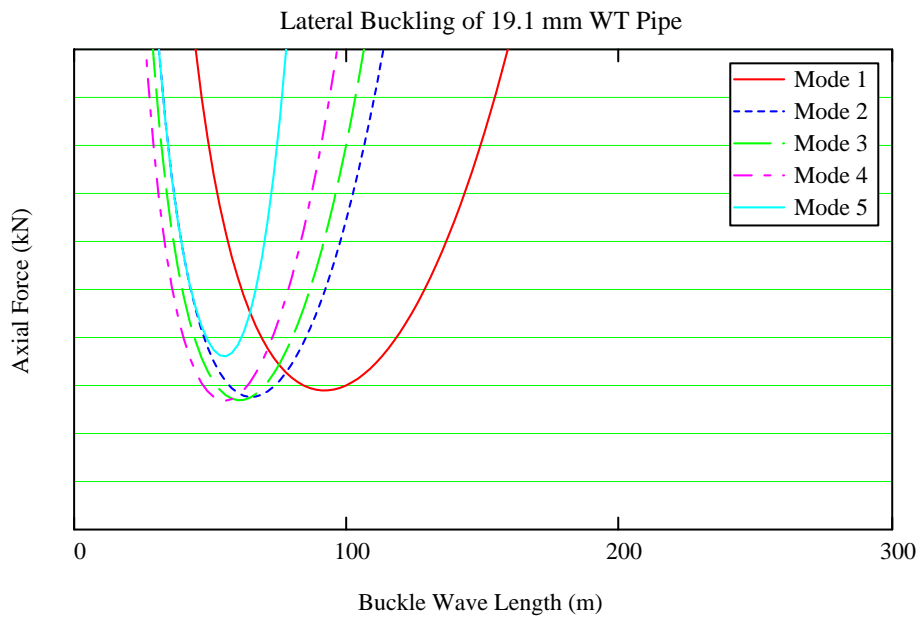

Calculate Critical buckling temperature and axial force for the specified lateral friction coefficient and a range of modes (The critical buckling temperature is changes only with pipe wall thickness and Friction factor):

$$aa := \min[(test_data_a)^{\langle 1 \rangle}] \quad aa = 3604.769$$

$$bb := \min(test_data_b^{\langle 1 \rangle}) \quad bb = 3481.919$$

$$cc := \min(test_data_c^{\langle 1 \rangle}) \quad cc = 3421.917$$

$$dd := \min(test_data_d^{\langle 1 \rangle}) \quad dd = 3414.596$$

$$ee := \min(test_data_e^{\langle 1 \rangle}) \quad ee = 4244.023$$

$$MinBuckleForce := \min[(test_data_a)^{\langle 1 \rangle}, (test_data_b)^{\langle 1 \rangle}, (test_data_c)^{\langle 1 \rangle}, (test_data_d)^{\langle 1 \rangle}, (test_data_e)^{\langle 1 \rangle}]$$

$$MinBuckleForce = 3414.596$$

APPENDIX

APPENDIX C

```
#####  
!  
!# #  
!# Date : May 2014 #  
!# Prepared By: Dawit Berhe #  
!# #  
!# #  
!# #  
#####
```

```
!FINISH  
!/CLEAR, START
```

```
#####!  
#####!  
/PREP7 !Enter model creation preprocessor
```

```
ANTYPE,STATIC,NEW !Specifies the analysis type and restart status
```

```
/TRIAD,rbot !Display XYZ triad in right bottom corner  
/OUTPUT,ZZZ_dawit,txt
```

```
!=====  
! Defining parameters  
! Units are [m] [N] [KG] [S] [deg]  
!=====
```

```
g=9.81 !Gravitational Acceleration [ms-2]
```

```
WD=800 !Water Depth [m]
```

```
OD=559E-3 !Outside Diameter
```

```
th=19.1E-3 !Wall Thickness [m]
```

```
!=====  
! Create the material,define element type, pipeline section and seabed friction!  
!=====
```

```
!-----  
!Element Type !  
!-----
```

```
ET,1,PIPE288 !Pipe elements  
ET,2,TARGE170 !Seabed element  
ET,3,CONTA175 !Contact element
```

```
!-----  
!Material Properties  
!-----
```

```
MPTEMP,1,0,95 !Defines a temperature table for material properties  
!MPTEMP, STLOC, T1, T2, T3, T4, T5, T6  
!STLOC: Starting location in table for entering temperatures.  
!For example, if STLOC = 1, data input in the T1 field  
applies to the first constant in the table
```

```
MP,EX,1,207E9 !Young's modulus for material ref. no. 1 is 207E9 (Nm-2)
```

MP,ALPX,1,1.17E-5 !Secant coefficient of thermal expansion, element x
 direction for material ref. no. 1 (1/deg)
 MP,PRXY,1,0.3 !Major Poisson's ratio, x-y plane for material ref. no. 1
 MP,DENS,1,10547 !Equivalent Density for submerged weight [kg/m^3]

TB,PLAS,1,2,30,MISO
 TBTEMP,20

TBPT	,,	0.000000	,	3.677E+08
TBPT	,,	0.000015	,	3.684E+08
TBPT	,,	0.000024	,	3.744E+08
TBPT	,,	0.000038	,	3.804E+08
TBPT	,,	0.000058	,	3.864E+08
TBPT	,,	0.000086	,	3.924E+08
TBPT	,,	0.000128	,	3.984E+08
TBPT	,,	0.000186	,	4.045E+08
TBPT	,,	0.000270	,	4.105E+08
TBPT	,,	0.000387	,	4.165E+08
TBPT	,,	0.000553	,	4.226E+08
TBPT	,,	0.000783	,	4.287E+08
TBPT	,,	0.001104	,	4.348E+08
TBPT	,,	0.001548	,	4.410E+08
TBPT	,,	0.002159	,	4.473E+08
TBPT	,,	0.002997	,	4.537E+08
TBPT	,,	0.004141	,	4.603E+08
TBPT	,,	0.005695	,	4.670E+08
TBPT	,,	0.007797	,	4.741E+08
TBPT	,,	0.010628	,	4.815E+08
TBPT	,,	0.014423	,	4.894E+08
TBPT	,,	0.019485	,	4.980E+08
TBPT	,,	0.026204	,	5.075E+08
TBPT	,,	0.035074	,	5.183E+08
TBPT	,,	0.046715	,	5.307E+08
TBPT	,,	0.061893	,	5.452E+08
TBPT	,,	0.081538	,	5.625E+08
TBPT	,,	0.106758	,	5.836E+08
TBPT	,,	0.138832	,	6.096E+08
TBPT	,,	0.179190	,	6.420E+08

TBTEMP,95

TBPT	,,	0.000000	,	3.290E+08
TBPT	,,	0.000022	,	3.295E+08
TBPT	,,	0.000034	,	3.354E+08
TBPT	,,	0.000052	,	3.413E+08
TBPT	,,	0.000077	,	3.472E+08
TBPT	,,	0.000113	,	3.531E+08
TBPT	,,	0.000165	,	3.590E+08
TBPT	,,	0.000238	,	3.649E+08
TBPT	,,	0.000340	,	3.708E+08
TBPT	,,	0.000483	,	3.767E+08
TBPT	,,	0.000682	,	3.827E+08
TBPT	,,	0.000956	,	3.887E+08
TBPT	,,	0.001334	,	3.947E+08
TBPT	,,	0.001851	,	4.008E+08
TBPT	,,	0.002555	,	4.070E+08
TBPT	,,	0.003510	,	4.133E+08
TBPT	,,	0.004798	,	4.197E+08
TBPT	,,	0.006529	,	4.264E+08
TBPT	,,	0.008843	,	4.333E+08
TBPT	,,	0.011922	,	4.406E+08
TBPT	,,	0.015999	,	4.484E+08
TBPT	,,	0.021373	,	4.568E+08
TBPT	,,	0.028419	,	4.661E+08

```
TBPT , , 0.037605 , 4.765E+08
TBPT , , 0.049512 , 4.884E+08
TBPT , , 0.064845 , 5.023E+08
TBPT , , 0.084449 , 5.186E+08
TBPT , , 0.109310 , 5.383E+08
TBPT , , 0.140558 , 5.622E+08
TBPT , , 0.179436 , 5.916E+08
```

```
!-----
!Seabed Friction
!-----
```

```
FRICLAX=0.35 !Soil friction coefficient in axial direction
FRICLLAT=0.6 !Soil friction coefficient in lateral direction
```

```
TB,FRIC,50,,,ORTHO !TB: Activates a data table for material properties
                    or special element input.
                    !FRIC - Coefficient of friction based on Coulomb's
                    Law or user-defined friction
                    !Define orthotropic soil friction
```

```
TBDATA,1,FRICLAX,FRICLLAT !TBDATA: Defines data for the material data table.
```

```
!-----
!Define section of pipeline
!-----
```

```
SECTYPE,1,PIPE !Define pipe Section type
SECDATA,OD,th !Define Pipe Section: Outer Dia. [m]
                    and Wall Thickness [m]
```

```
!-----
!Define real constant
!-----
```

```
R,200,,,1e-6 !Defines the element real constants
```

```
!-----
!Defining Key point for PIPELINE
!-----
```

```
local,11,0,0,0,0,0,0,0,0
K, 1 , 0 , 0 , 0
K, 2 , 50 , 0 , 0
K, 3 , 100 , 0 , 0
k, 4 , 150 , 0 , 0
K, 5 , 250 , 0 , 0
K, 6 , 300 , 0 , 0
K, 7 , 350 , 0 , 0
K, 8 , 400 , 0 , 0
K, 9 , 410 , 0 , 0
K, 10 , 452.9 , 0 , 0.46
k, 11 , 499.4 , 0 , 1.0
K, 12 , 545.9 , 0 , 0.46
K, 13 , 588.8 , 0 , 0
K, 14 , 600 , 0 , 0
K, 15 , 650 , 0 , 0
K, 16 , 700 , 0 , 0
K, 17 , 750 , 0 , 0
```

```

K, 18 , 800 , 0 , 0
K, 19 , 850 , 0 , 0
K, 20 , 900 , 0 , 0
K, 21 , 1000 , 0 , 0

*get,ant_k,kp,0,count
clocal,12,0,kx(ant_k),ky(ant_k),kz(ant_k),0,0,180
csys,0

k,22, 350 , 0 , 200
k,33, 400 , 0 , 200
k,44, 450 , 0 , 200
k,55, 500 , 0 , 200

!-----
!Generate Lines
!-----

*DO,I,1,8          !Define line between two keypoints

    L,I,I+1

*ENDDO

larc,9,10,22,2000
larc,10,11,33,2000
larc,11,12,44,2000
larc,12,13,55,2000

*DO,I,13,20       !Define line between two keypoints

    L,I,I+1

*ENDDO

!-----
!Select Line, E Size and Meshing
!-----

ESIZE,1.0*OD      !Specifies the default number of line divisions

TYPE,1            !Select element type 1
MAT,1             !Sets the element material attribute pointer
SECNUM,1          !Sets the element section attribute pointer

LSEL,S,LINE,,1,ant_k-1      !Select The lines
LMESH,ALL           !Mesh the Element

!SORT THE ELEMENTS IN ORDER
ALLSEL
ESEL,S,ENAME,,288
WSORT,ALL
NUMCMP,ELEM,EORD

e1=node(kx(1),ky(1),kz(1))   !Identify end node and
csys,11                      !Change coordinate system
nrotat,e1                    !Rotate node into new coordinate system

e2=node(kx(ant_k),ky(ant_k),kz(ant_k)) !Identify end node and
csys,12                      !change nodal coordinate system
nrotat,e2

```

csys,0

!=====
!---GRAPHIC SETTING SEABED---

!=====!

!-----
!Defining Key point for Seabed
!-----

K, 3001 , -30.0 , 0 , 30
K, 3002 , 1030 , 0 , 30
K, 3003 , 1030 , 0 , -30
K, 3004 , -30.0 , 0 , -30

!-----
!Defining Area from key points
!-----

A,3001,3002,3003,3004

!-----
!Meshing The Area
!-----

ASEL,S,,1

TYPE,2 *!Select element type 2*
REAL,200 *!Defines the element real constants*
ESIZE,20
NUMSTR,ELEM,1000
AMESH,ALL

!-----
!Meshing The Contact Element
!-----

!NSEL,S,LOC,Y,0,0 *!Reselect nodes (DOF) in Y-direction*

ALLS
LSEL,S,LINE,,1,ant_k-1 *!Select The lines*
ESLL,S,1
TYPE,3 *!Select element type 3*
MAT,50 *!Sets the element material attribute pointer*
REAL,200 *!Defines the element real constants*
ESURF *!Generate contact elements overlaid*
on the free faces of existing selected elements
ALLSEL *!Seabed done*

SAVE

/ESHAPE,1
EPLLOT

FINI

ALLSEL
SOLVE

Feed-in

push_1= 2
NSTP =20 ! NO. OF LOAD STEPS USED
 T1 = push_1/NSTP ! ROTATION PER LOAD STEP

 T3 = T1 ! CURRENT ANGLE

***DO,II,1,NSTP** ! USE DO LOOP FOR LOADING

!ESEL,S,ENAME,,288

d,e1,ux,T3

d,e2,ux,T3

NSUBST,100,500,10

NEQIT,100

ALLSEL

SOLVE

Save

T3 = T3+T1

***ENDDO**

```

/POST1
!#####
!#          ENTERING POST-PROCESSOR          #

!#####
!/OUTPUT,WWW,TXT
ALLS
set,22
ESEL,S,ENAME,,288
ETABLE,MYI,SMISC,2
ETABLE,MYJ,SMISC,15
ETABLE,MZI,SMISC,3
ETABLE,MZJ,SMISC,16
ETABLE,EffAxiI,SMISC,1
ETABLE,EffAxiJ,SMISC,14
ETABLE,ETensI,SMISC,63
ETABLE,ETensJ,SMISC,67

!List the ETABLE values
!-----

PRETAB,MYI,MYJ,MZI,MZJ,EffTensI,EffTensJ,ETensI,ETensJ

!The *GET command can be used to extract virtually
!any type of data from the database
!Insert the *GET command to find the number of pipe elements
!contained in the model, and store this value in a parameter
!-----

!*DIM command
!create an ARRAY type parameter with number of rows equal
!to the number of pipe elements in the model (found in point 1)
!and 4 columns

*GET,E_SELECTED,ELEM,0,COUNT          !par: E_SELECTED
                                     !Entity: ELEM
                                     !Entnum: 0; a zero (or blank) ENTNUM
                                     represents all entities of the set
                                     !Item1: COUNT

*DIM,FTab,ARRAY,E_SELECTED,9          !par: FTab
                                     !Type: ARRAY
                                     !IMAX: E_SELECTED --> Extent of first dimension (row)
                                     !JMAX: 5 --> Extent of second dimension (column)

!=====
!=====

! Løkke som går gjennom alle vagte elementer.
! SKREVET AV LARS KALLUM, ENGINEERING DATA RESOURCES
! Loop that goes through all vaguely Elements.
! WRITTEN BY LARS KALLUM, ENGINEERING DATA RESOURCES
!=====

*GET,ELEM_NUMMAX,ELEM,0,NUM,MAX
!In this case 250 based on LESIZE
*GET,ELEM_NUMMIN,ELEM,0,NUM,MIN

```

```

*           !In this case 1 based on LESIZE

ELEM_CURRENT=ELEM_NUMMIN           !ELEM_CURRENT=1

CONTINUE_LOOP=ELEM_NUMMAX         !CONTINUE_LOOP=250
LOOP_NO=0

*DOWHILE,CONTINUE_LOOP
!*DOWHILE,250 Loops repeatedly through the next *ENDDO command

  **** HER KOMMER INNHOLD/OPERASJONER SOM SKAL GJØRES ****
  **** HERE ARE CONTENT / OPERATIONS TO BE MADE ****

  LOOP_NO=LOOP_NO+1
  FTab(LOOP_NO,1)=ELEM_CURRENT
  *GET,FTab(LOOP_NO,2),ETAB,1,ELEM,ELEM_CURRENT
    !Entity:ETAB; ENTNUM:N (Column number)
    !Item1:ELEM --> value in ETABLE column N for
    !Element Number ELEM_CURRENT
  *GET,FTab(LOOP_NO,3),ETAB,2,ELEM,ELEM_CURRENT
  *GET,FTab(LOOP_NO,4),ETAB,3,ELEM,ELEM_CURRENT
  *GET,FTab(LOOP_NO,5),ETAB,4,ELEM,ELEM_CURRENT
  *GET,FTab(LOOP_NO,6),ETAB,5,ELEM,ELEM_CURRENT
  *GET,FTab(LOOP_NO,7),ETAB,6,ELEM,ELEM_CURRENT
  *GET,FTab(LOOP_NO,8),ETAB,7,ELEM,ELEM_CURRENT
*GET,FTab(LOOP_NO,9),ETAB,8,ELEM,ELEM_CURRENT

  **** KONTROLL AV LØKKEN ****
  **** CONTROL LOOP ****

  CONTINUE_LOOP=ELEM_NUMMAX-ELEM_CURRENT
  *GET,ELEM_NEXT,ELEM,ELEM_CURRENT,NXTH
  ELEM_CURRENT=ELEM_NEXT

*ENDDO

*CFOPEN, PIPE_RESULTS_UB_22, CSV

*VWRITE, 'ELEM NO','MYI','MYJ','MZI','MZJ','EffAxii'
* 'EffAxij','ETensI','ETensJ'

  %C; %C; %C; %C; %C; %C; %C; %C; %C

*VWRITE, FTab(1,1), FTab(1,2), FTab(1,3), FTab(1,4), FTab(1,5),
* FTab(1,6), FTab(1,7), FTab(1,8), FTab(1,9)

  %G; %G; %G; %G; %G; %G; %G; %G; %G

*CFCLOSE

  !%C For alphanumeric character data
  !%G For double precision data
  !=====
  !=====

```

APPENDIX

APPENDIX D

```

#####
!#
!#      END WXPANSION ANSYS SCRIPT : LONG PIPELINE
!#
!#
!#      Date   :   May 2014
!#
!#      Prepared by:   Dawit Berhe
!#
!#
!#####
!
!Filename: End_expansion
!Description: End Expansions Calculations
!#####

*SET,model_id,'End Expansion'

/TITLE,%model_id%
/FILNAM,%model_id%
/ESHAPE,1                !Display elements as solids
/TRIAD,rbot              !Display XYZ triad in right bottom corner
/PSYMB,NDIR,1           !Display nodal coord. system if other than global

/UNITS,MKS                !MKS system (m, kg, s, deg C).
!#####
!Defining parameters
!Units are [m] [N] [KG] [S] [deg]
!#####

pi=4*ATAN(1.0)           !Pi
g=9.81                   !Gravitational Acceleration (ms^-2)

WD=800                   !Water Depth (m)
RADc=100                 !Radius of Curvature in a normally straight pipe

igap=0                   !Initial gap between pipeline and seabed
bgap=0                   !Gap between pipe to the peakseabed profile

/PREP7                   !Enter model creation preprocessor
!ANTYPE,0,NEW            !0=STATIC
ACEL,,g                  !Define gravity

ET,1,PIPE288             !Pipe elements
SECTYPE,1,PIPE           !Define pipe Section type
SECDATA,559E-3,19.1E-3   !Define Pipe Section:Outer Dia. and Wall Thickness [M]

ET,2,TARGE170           !Seabed element
ET,3,CONTA175           !Contact elements
!#####
!Defining PIPELINE DATA
!#####
!#PHYSICAL DATA

OD=559E-3                !Pipe Outer Diameter (m)
twall=19.1E-3            !Pipe Wall Thickness (m)
Din=OD-2*twall          !Pipe Internal Diameter (m)
L=10000                  !Pipe Model Length (m)
!
t_ext=5E-3               !External Coating Thickness (m)
t_conc=55E-3            !Concrete Coating Thickness (m)

!#OPERATIONAL DATA

```

```

D_w=1025                !WaterDensity (kgm^-3)
D_cont=900              !Content Density (kgm^-3)
D_st=7850               !Pipe steel Density (kgm^-3)

P_des=15E6              !Design Pressure (Nm^-2)
P_op=15E6               !Operational Pressure (Nm^-2)
P_hyd=0E6               !Hydrotest Pressure

T_amb=5                !Ambient Temperature
T_op=95                !Operating Temperature

!N_Ray=0                !Residual Lay Tension

!#MATERIAL PROPERTIES

MPTEMP,1,0,95          ! Define temperatures for Young's modulus
MP,EX,1,207E9          !Young's Modulus (Nm^-2)
MP,ALPX,1,1.17E-5      !Thermal expansion Coefficient (1/deg)
MP,PRXY,1,0.3          !Poisson Ratio
MP,DENS,1,D_st

D_ext=910               !Insulation or Coating Density (kgm^-3)
D_conc=2400             !Concrete coating density (kgm^-3)

!-----
!          SEABED DATA
!-----
FRICLAX=0.6            ! Soil friction coefficient in axial direction
FRICLLAT=0.80         ! Soil friction coefficient in lateral direction

TB,FRIC,2,, ,ORTHO     ! Define orthotropic soil friction
TBDATA,1,FRICLAX,FRICLLAT

!#####
!**RELEVANT CONNECTING EQUATION
!#####
D_eff=OD+2*(t_ext+t_conc) ! Effective Pipe Diameter (m)
Ast=pi*(OD**2-Din**2)/4   ! Cross-sectional Area of Pipe Steel (m^2)
Ast_ext=pi*((OD+2*t_ext)**2-OD**2)/4 ! Cross-sectional Area of External
                                Coating (m^2)
Ast_conc=pi*((OD+2*t_ext+2*t_conc)**2-(OD+2*t_ext)**2)/4 ! Cross-sectional Area
                                of Concrete Coating (m^2)
M_st=Ast*D_st              ! Pipe Steel Mass (Kg/m)
M_ext=Ast_ext*D_ext        ! External Coating Mass (Kg/m)
M_conc=Ast_conc*D_conc     ! Concrete Coating Mass (Kg/m)
M_cont=pi*(Din**2)*D_cont/4 ! Content Mass (Kg/m)
M_water=pi*(Din**2)*D_w/4 ! Water Mass (Kg/m)

M_bouy=pi*(D_eff**2)*D_w/4 ! Buoyancy Mass (Kg/m)
M_air=M_st+M_ext+M_conc+M_cont ! Pipeline Total Mass (Kg/m) (weight on air)
M_sub=M_air-M_bouy         ! Submerged Mass (Kg/m) (weight in water)

W_cont=M_cont*g           ! Content Weight (N/m)
W_water=M_water*g         ! Flooded Weight (N/m)
W_sub=M_sub*g             ! Empty Pipe Submerged Weight (N/m)
DEN_equiv=M_sub/Ast       ! Submerged pipe Equivalent Density (kg/m^3)

D_insul=((t_ext*D_ext)+(t_conc*D_conc))/(t_ext+t_conc) !
                                Insulation Eqv. Density (Corr. & Concr. Coat.) (N/m)
t_insul=t_ext+t_conc     ! Insulation thickness (Corr. & Concr. Coat.) (m)
A_insul=Ast_ext+Ast_     ! Insulation Area (Corrosion coat.& Concrete Coat.) (m^2)

```

```

#####
!***UPDATE WEIGHT ON PIPELINE !EQUIVALENT DENSITY APPLIED TO SUBMERGED WEIGHT #
#####

!MP,DENS,1,DEN_equiv           ! Pipe Material density (Kg/m^3)
SECCONTROLS,M_cont           ! overrides default section properties.added mass:
                             Content(kg/m)

#####
!***ELEMENT REAL CONSTANT                                           #
#####
#####!

KEYOPT,1,1,0           ! Temperature Through wall gradient
!KEYOPT,1,3,0           ! linear shape functions
KEYOPT,1,4,1           ! Thin Pipe Theory
KEYOPT,1,6,0           ! Internal and External pressure cause loads on end caps
KEYOPT,1,7,0           ! Output control for section forces/moments and strains
KEYOPT,1,8,0           ! Output control at integration points
                       (1=Maximum and minimum stresses/strains)
KEYOPT,1,9,2           ! Maximum and minimum stresses/strains
                       plus stresses and strains at each section node
KEYOPT,1,15,0          ! One result for each section integration point

#####
!# SEABED !
#####
!R,22,,1,0.2           ! Define Normal Contact Stiffness Factor and Penetration
                       Tolerance Factor
                       ! (use ANSYS default)

KEYOPT,3,10,2          ! Set option 10 (Contact Stiffnes Update) for element
                       type 3 to 2 (Each substep based on mean
! stress of underlying elements from the previous substep (pair based))
! Update stiffness automaticly based on maximum penetration

KEYOPT,3,2,1           ! Penalty method, static stiffness of seabed
!KEYOPT,3,3           ! Contact M0del: (0)Contact Force Based (1)Contact traction based
KEYOPT,3,4,2           ! Normal from contact nodes
!KEYOPT,3,5,3           ! Either Close the gap or reduces initial penetration
!KEYOPT,3,9,4           ! Include offset only
                       (exclude initial geometrical penetration or gap), but with ramped effects
KEYOPT,3,10,2          ! Applying the normal contact stiffness by a factor of
                       0.2 for each bisection
KEYOPT,3,12,0          ! Behaviour of Contact Surface (0=standard)

#####
!Generate nodes and pipe element:
#####

nod1= 1                 !first node number
nodn= 2499              !last nodenumber
nelem=nodn-1           !number of elements in pipe
midnode=(nodn+1)/2     !midnode
elength=L/nelem        !length of an element

n,nod1,0,0,0           !position of first pipenode
n,nodn,L,0,0           !position of last pipenode
fill,nod1,nodn         !fill a row of nodes between nod1 and nodn

numstr,elem,1         !element numbering from 1
e,1,2                 !create pipeelement nod1 and nod2

```

```

*repeat,nelem,1,1                                !create the all the pipeelement

nset,all                                          !select all nodes
nset,s,node,,1,nodn                              !select the pipenodes
cm,pipenodes,node                               !make it a single component

nset,all
esel,s,type,,1                                  !select element by type
cm,pipeelem,elem                                !make it a pipeeeleme

esel, all

#####
!**MESHING SEABED ELEMENT
#####

! Define nodes for seabed area
N, 3001 , -100.0 , -igap , 100
N, 3002 , 10100 , -igap , 100
N, 3003 , 10100 , -igap , -100
N, 3004 , -100.0 , -igap , -100

!#DEFINE TARGET ELEMENT##
#####

numstr,elem,2990
TYPE,2          ! Select material and properties for seabed
MAT,2
REAL,22
TSHAPE,QUAD     ! SET TARGET SHAPE
E,3001,3002,3003,3004 ! Define Element

numstr,elem,3001
type,3
real,22
mat,2

NSEL,R,LOC,Y,0      ! Reselect nodes (DOF) in Y-direction
ESURF              ! Generate contact elements overlaid on the free faces
                  of existing selected elements

ALLSEL            ! - Seabed done

#####
!          DISPLAY MODEL                                     #
#####
/ESHAPE,1          ! Display elements as solids
/TRIAD,rbot       ! Display XYZ triad in right bottom corner
/PSYMB,NDIR,1     ! Display nodal coord. system if other than globa

WAVES             ! Initiates reordering for the solution phase
WSORT            ! Sorts elements based on geometric sort
!WMID,YES
SAVE             ! Save all current database information
PARSAV,ALL,Latbuck,txt ! Save parameters to latbuck.txt

FINISH          ! Exit the preprocessor
!/EOF

#####
!          SOLUTION                                         #

```

```

#####
/CONFIG,NRES,30000

/solu                               !Enter solution processor
ANTYPE,TRANS                       !NEW STATIC SOLUTION
solcontrol,on                      !solution control on activates
                                     optimized defaults
                                     !for a set of commands applicable to
                                     nonlinear solutions
nlgeom,on                          !Includes large-deflection effects in a
                                     static or full transient analysis.
autots,on                          !automatic timestepping on
NROPT,UNSYM                       ! Specifies the Newton-Raphson options in a static or
                                     full transient analysis  !
(FULL or UNSYM= the stiffness matrix is updated at every equilibrium iteration)

!NSUBST,10,20,10                   ! Specifies the number of substeps to be taken every
                                     load step (nbr this step, maximum number of
                                     ! substeps to be taken (i.e. min. time step), minimum number of step
                                     (i.e. max time step)
neqit,1000                         !Specifies the maximum number of
                                     equilibrium iterations for nonlinear analyses.

pstres,on                          !Calculate (or include) prestress effects
lnsrch,on                          !Activates a line search to be used
                                     with Newton-Raphson.
parres,,Latbuck,txt               !Reads parameters from a latbuck.txt file.
tref,T_amb                        !Defines the reference temperature for
                                     the thermal strain calculations.
                                     !Thermal strains are given by  $\alpha *(T-TREF)$ 
sfcum,pres,repl                  !cumulative surface load on
bfcum,temp,repl
cncheck,auto                     !Automatically sets certain real constants
                                     and key options to recommended values

#####
!      LOAD STEPS AND BOUNDARY CONDITION      #
#####
!The word loads as used in ANSYS documentation includes boundary conditions
!(constraints, supports, or boundary field specifications) as well as other
!externally and internally applied loads

TIME,1
/stitle,1,Lay pipeline on seabed and Apply boundary condition,set imperfection
on pipeline and apply internal and external presure

f,pipelem,fy,-(W_sub*elength)
sfe,pipeelem,2,pres,,D_w*g*(WD)      !The hydrostatic pressure @ 800m WD (N/m)

NSUBST,15,20,10

solve
!save
!fini
!/EOF

TIME,2
/stitle,1,Appy operating pressure and temperature

sfe,pipeelem,1,pres,,P_op
tload_2.mac

```

NSUBST,15

allsel
solve
save
!/EOF

```
#####  
!      POSTPROCESSOR                                     #  
#####  
/POST1
```

/OUTPUT,RESULTS %model_id%,OUT ! Save file as RESULTS.OUT

*DO,i,2,2.9,0.1 ! To Time:3

SET,,,,i

ESEL,S,ELEM,,1000,1800 ! Select Element number

!ESEL,R,ENAME,,PIPE288 ! Reselect Element Name

! Extract Axial Force

!ETABLE FOR AXIAL FORCE

ETABLE,AF1,SMISC,1 !Node "I"

ETABLE,AFn,NMISC,14 !Node "J"

SABS,1

SMAX,FX,AF1,AFn !Max Value Axial Force

!ETABLE FOR BENDING MOMENT ! Extract Moments

ETABLE,BMY1,SMISC,2 !Node "I"

ETABLE,BMYn,NMISC,15 !Node "J"

SABS,1

SMAX,My,BMY1,BMYn !Max Value

ETABLE,BMZ1,SMISC,3 !Node "I"

ETABLE,BMZn,NMISC,16 !Node "J"

SABS,1

SMAX,Mz,BMZ1,BMZn !Max Value

ETABLE,Eqv.Strain,EPTT,EQV ! Extract Equivalent Total Strain

! Elastic+Plastic+Creep+Thermal Strains ! EXTRACT STRESSES

!ETABLE FOR HOOPSTRESS

ETABLE,HP1,SMISC,64

ETABLE,HPn,SMISC,68

SABS,1

SMAX,HOOPStr,HP1,HPn ! Max Value HOOP Stress

!ETABLE FOR AXIALSTRESS

ETABLE,AX1,SMISC,31 ! Node "I"

ETABLE,AXn,SMISC,36 ! Node "J"

SABS,1

SMAX,AXIALStr,AX1,AXn ! Max Value Stress due to Axial Load

!ETABLE FOR bending stress [I]

ETABLE,BS1,SMISC,34 ! Node "I" Stress due to Bending moment

ETABLE,BSn,SMISC,35

SABS,1

SMAX,bend1,BS1,BSn

!ETABLE FOR bending stress [J] ! Node "J" Stress due to Bending moment

```

ETABLE,BD1,SMISC,39
ETABLE,BDn,SMISC,40
SABS,1
SMAX,bend2,BD1,BDn

SMAX,LONGTDLStr,bend1,bend2           ! Max Value Longitudinal Stress
           ! due to bending moment

PRETAB,FX,My,Mz,HOOPStr,LONGTDLStr,AXIALStr,Eqv.Strain!Display Result on Table

*ENDDO

/OUTPUT,DISPLACEMENT %LOADCASE%,OUT      ! Save file as RESULTS.OUT
*DO,i,2,2.9,0.1           ! To Time:3
  SET,,,,i
  ESEL,S,ELEM,,1000,1800      ! Select Element number
  !ESEL,R,ENAME,,PIPE288      ! Reselect Element Name

  ETABLE,DispX,U,X
  ETABLE,DispY,U,Y
  ETABLE,DispZ,U,Z

  PRETAB,DispX,DispY,DispZ
  !PRETAB,DispY,DispZ

*ENDDO

/OUTPUT,
FINI
ALLSEL
!/EOF

```

```

#####
!#
!#      END EXPANSION ANSYS SCRIPT: SHORT PIPELINE
!#
!#
!#      Date   :   May 2014
!#
!#      Prepared by:   Dawit Berhe
!#
#####
!
!Filename: End_expansion
!Description: End Expansions Calculations
#####

*SET,model_id,'End Expansion'

/TITLE,%model_id%
/FILNAM,%model_id%
/ESHAPE,1                !Display elements as solids
/TRIAD,rbot              !Display XYZ triad in right bottom corner
/PSYMB,NDIR,1           !Display nodal coord. system if other than global

/UNITS,MKS                !MKS system (m, kg, s, deg C).
#####
!Defining parameters
!Units are [m] [N] [KG] [S] [deg]
#####

pi=4*ATAN(1.0)           !Pi
g=9.81                   !Gravitational Acceleration (ms^-2)

WD=800                   !Water Depth (m)
RADc=100                 !Radius of Curvature in a normally straight pipe

igap=0                   !Initial gap between pipeline and seabed
bgap=0                   !Gap between pipe to the peakseabed profile

/PREP7                   !Enter model creation preprocessor
!ANTYPE,0,NEW            !0=STATIC
ACEL,,g                  !Define gravity

ET,1,PIPE288             !Pipe elements
SECTYPE,1,PIPE           !Define pipe Section type
SECDATA,559E-3,19.1E-3   !Define Pipe Section:Outer Dia. and Wall Thickness [M]

ET,2,TARGE170           !Seabed element
ET,3,CONTA175           !Contact elements
#####
!Defining PIPELINE DATA
#####
!#PHYSICAL DATA

OD=559E-3                !Pipe Outer Diameter (m)
twall=19.1E-3            !Pipe Wall Thickness (m)
Din=OD-2*twall          !Pipe Internal Diameter (m)
L=2000                   !Pipe Model Length (m)
!
t_ext=5E-3               !External Coating Thickness (m)
t_conc=55E-3             !Concrete Coating Thickness (m)

!#OPERATIONAL DATA

```

```

D_w=1025                !WaterDensity (kgm^-3)
D_cont=900              !Content Density (kgm^-3)
D_st=7850               !Pipe steel Density (kgm^-3)

P_des=15E6              !Design Pressure (Nm^-2)
P_op=15E6              !Operational Pressure (Nm^-2)
P_hyd=0E6              !Hydrotest Pressure

T_amb=5                !Ambient Temperature
T_op=95                !Operating Temperature

!N_Ray=0               !Residual Lay Tension

!#MATERIAL PROPERTIES

MPTEMP,1,0,95          ! Define temperatures for Young's modulus
MP,EX,1,207E9          !Young's Modulus (Nm^-2)
MP,ALPX,1,1.17E-5     !Thermal expansion Coefficient (1/deg)
MP,PRXY,1,0.3         !Poisson Ratio
MP,DENS,1,D_st

D_ext=910              !Insulation or Coating Density (kgm^-3)
D_conc=2400            !Concrete coating density (kgm^-3)

!-----
!          SEABED DATA
!-----
!DEFINE SEABED SOIL FRICTION
FRICLAX=0.40          ! Soil friction coefficient in axial direction
FRICLLAT=0.60        ! Soil friction coefficient in lateral direction

TB,FRIC,2,, ,ORTHO    ! Define orthotropic soil friction
TBDATA,1,FRICLAX,FRICLLAT

!#####
!**RELEVANT CONNECTING EQUATION
!#####

D_eff=OD+2*(t_ext+t_conc) ! Effective Pipe Diameter (m)
Ast=pi*(OD**2-Din**2)/4   ! Cross-sectional Area of Pipe Steel (m^2)
Ast_ext=pi*((OD+2*t_ext)**2-OD**2)/4 ! Cross-sectional Area of External Coating
                                     (m^2)
Ast_conc=pi*((OD+2*t_ext+2*t_conc)**2-(OD+2*t_ext)**2)/4 ! Cross-sectional
                                     Area of Concrete Coating (m^2)

M_st=Ast*D_st            ! Pipe Steel Mass (Kg/m)
M_ext=Ast_ext*D_ext      ! External Coating Mass (Kg/m)
M_conc=Ast_conc*D_conc   ! Concrete Coating Mass (Kg/m)
M_cont=pi*(Din**2)*D_cont/4 ! Content Mass (Kg/m)
M_water=pi*(Din**2)*D_w/4 ! Water Mass (Kg/m)

M_bouy=pi*(D_eff**2)*D_w/4 ! Buoyancy Mass (Kg/m)
M_air=M_st+M_ext+M_conc+M_cont ! Pipeline Total Mass (Kg/m) (weight on air)
M_sub=M_air-M_bouy        ! Submerged Mass (Kg/m) (weight in water)

W_cont=M_cont*g          ! Content Weight (N/m)
W_water=M_water*g        ! Flooded Weight (N/m)
W_sub=M_sub*g            ! Empty Pipe Submerged Weight (N/m)
DEN_equiv=M_sub/Ast      ! Submerged pipe Equivalent Density (kg/m^3)

D_insul=((t_ext*D_ext)+(t_conc*D_conc))/(t_ext+t_conc) ! Insulation Eqv.
                                     Density (Corr. & Concr. Coat.) (N/m)
t_insul=t_ext+t_conc     ! Insulation thickness (Corr. & Concr. Coat.) (m)
A_insul=Ast_ext+Ast_c ! Insulation Area (Corrosion coat.& Concrete Coat.) (m^2)

```

```

#####
!**UPDATE WEIGHT ON PIPELINE !EQUIVALENT DENSITY APPLIED TO SUBMERGED WEIGHT #
#####

!MP,DENS,1,DEN_equiv           ! Pipe Material density (Kg/m^3)
!SECCONTROLS,M_cont           ! overrides default section properties.added mass:
                               Content(kg/m)

#####
!**ELEMENT REAL CONSTANT #
#####
!# FOR PIPELINE !
#####

KEYOPT,1,1,0           ! Temperature Through wall gradient
!KEYOPT,1,3,0           ! linear shape functions
KEYOPT,1,4,1           ! Thin Pipe Theory
KEYOPT,1,6,0           ! Internal and External pressure cause loads on end caps
KEYOPT,1,7,0           ! Output control for section forces/moments and strains
KEYOPT,1,8,0           ! Output control at integration points (1=Maximum and
                               minimum stresses/strains)
KEYOPT,1,9,2           ! Maximum and minimum stresses/strains + plus
                               stresses and strains at each section node
KEYOPT,1,15,0          ! One result for each section integration point

#####
!# SEABED !
#####
!R,22,,1,0.2           ! Define Normal Contact Stiffness Factor and Penetration
                               Tolerance Factor
                               ! (use ANSYS default)

KEYOPT,3,10,2          ! Set option 10 (Contact Stiffnes Update) for element
                               type 3 to 2 (Each substep based on mean
                               ! stress of underlying elements from the previous substep (pair based))
                               ! Update stiffness automaticly based on maximum penetration

KEYOPT,3,2,1           ! Penalty method, static stiffness of seabed
!KEYOPT,3,3,1           ! Contact MModel: (0)Contact Force Based (1)Contact traction based
KEYOPT,3,4,2           ! Normal from contact nodes
!KEYOPT,3,5,3           ! Either Close the gap or reduces initial penetration
!KEYOPT,3,9,4           ! Include offset only (exclude initial geometrical
                               penetration or gap), but with ramped effects
KEYOPT,3,10,2          ! Applying the normal contact stiffness by a factor of
                               0.2 for each bisection
KEYOPT,3,12,0          ! Behaviour of Contact Surface (0=standard)

#####
!Generate nodes and pipe element: #
#####

nod1= 1                 !first node number
nodn= 999               !last nodenumber
nelem=nodn-1           !number of elements in pipe
midnode=(nodn+1)/2     !midnode
elength=L/nelem        !length of an element

n,nod1,0,0,0           !position of first pipenode
n,nodn,L,0,0           !position of last pipenode
fill,nod1,nodn         !fill a row of nodes between nod1 and nodn

numstr,elem,1         !element numbering from 1

```



```

#####
!          SOLUTION                                     #
#####

/CONFIG,NRES,30000

/solu                                !Enter solution processor
ANTYPE,TRANS                        !NEW STATIC SOLUTION
solcontrol,on                       !solution control on activates optimized defaults
                                     !for a set of commands applicable to nonlinear solutions
nlgeom,on                            !Includes large-deflection effects in
                                     a static or full transient analysis.
autots,on                            !automatic timestepping on
NROPT,UNSYM    ! Specifies the Newton-Raphson options in a static or full
                                     transient analysi
                                     ! (FULL or UNSYM= the stiffness matrix is updated at every
                                     equilibrium iteration)

!NSUBST,10,20,10                    ! Specifies the number of substeps to be taken every
                                     load step (nbr this step, maximum number of
                                     ! substeps to be taken (i.e. min. time step), minimum number
                                     of step (i.e. max time step)
neqit,1000                          !Specifies the maximum number of equilibrium iterations
                                     for nonlinear analyses.

pstres,on                            !Calculate (or include) prestress effects
lnsrch,on                            !Activates a line search to be used with Newton-Raphson.
parres,,Latbuck,txt                 !Reads parameters from a latbuck.txt file.
tref,T_amb                          !Defines the reference temperature for
                                     the thermal strain calculations.
                                     !Thermal strains are given by  $\alpha * (T-TREF)$ 
sfcum,pres,reprl                   !cumulative surface load on
bfcum,temp,reprl
cncheck,auto                       !Automatically sets certain real constants
                                     and key options to recommended values

#####
!          LOAD STEPS AND BOUNDARY CONDITION         #
#####
!The word loads as used in ANSYS documentation includes boundary conditions
!(constraints, supports, or boundary field specifications) as well as other
!externally and internally applied loads

TIME,1
/stitle,1,Lay pipeline on seabed and Apply boundary condition,set imperfection
on pipeline and apply internal and external presure

f,pipe nodes,fy,-(W_sub*elength)
sfe,pipeelem,2,pres,,D_w*g*(WD)    !The hydrostatic pressure @ 800m WD (N/m)

NSUBST,15,20,10

solve
!save
!fini
!/EOF

TIME,2
/stitle,1,Appy operating pressure and temperature

sfe,pipeelem,1,pres,,P_op

```

tload_2.mac

NSUBST,15

allsel
solve
save
!/EOF

```
#####  
!      POSTPROCESSOR                                     #  
#####
```

/POST1

/OUTPUT,RESULTS %model_id%,OUT ! Save file as RESULTS.OUT

*DO,i,2,2.9,0.1 ! To Time:3

SET,,,,i

ESEL,S,ELEM,,1000,1800 ! Select Element number

!ESEL,R,ENAME,,PIPE288 ! Reselect Element Name

! Extract Axial Force

!ETABLE FOR AXIAL FORCE

ETABLE,AF1,SMISC,1 !Node "I"

ETABLE,AFn,NMISC,14 !Node "J"

SABS,1

SMAX,FX,AF1,AFn !Max Value Axial Force

!ETABLE FOR BENDING MOMENT ! Extract Moments

ETABLE,BMY1,SMISC,2 !Node "I"

ETABLE,BMYn,NMISC,15 !Node "J"

SABS,1

SMAX,My,BMY1,BMYn !Max Value

ETABLE,BMZ1,SMISC,3 !Node "I"

ETABLE,BMZn,NMISC,16 !Node "J"

SABS,1

SMAX,Mz,BMZ1,BMZn !Max Value

ETABLE,Eqv.Strain,EPTT,EQV ! Extract Equivalent Total Strain

! Elastic+Plastic+Creep+Thermal Strains ! EXTRACT STRESSES

!ETABLE FOR HOOPSTRESS

ETABLE,HP1,SMISC,64

ETABLE,HPn,SMISC,68

SABS,1

SMAX,HOOPStr,HP1,HPn ! Max Value HOOP Stress

!ETABLE FOR AXIALSTRESS

ETABLE,AX1,SMISC,31 ! Node "I"

ETABLE,AXn,SMISC,36 ! Node "J"

SABS,1

SMAX,AXIALStr,AX1,AXn ! Max Value Stress due to Axial Load

!ETABLE FOR bending stress [I]

ETABLE,BS1,SMISC,34 ! Node "I" Stress due to Bending moment

ETABLE,BSn,SMISC,35

SABS,1

SMAX,bend1,BS1,BSn

```

!ETABLE FOR bending stress [J]                ! Node "J" Stress due to Bending moment

ETABLE,BD1,SMISC,39
ETABLE,BDn,SMISC,40
SABS,1
SMAX,bend2,BD1,BDn

SMAX,LONGTDLStr,bend1,bend2                ! Max Value Longitudinal Stress
! due to bending moment

PRETAB,FX,My,Mz,HOOPStr,LONGTDLStr,AXIALStr,Eqv.Strai! Display Result on Table

*ENDDO

/OUTPUT,DISPLACEMENT %LOADCASE%,OUT        ! Save file as RESULTS.OUT
*DO,i,2,2.9,0.1                            ! To Time:3
SET,,,,,i
ESEL,S,ELEM,,1000,1800                    ! Select Element number
!ESEL,R,ENAME,,PIPE288                    ! Reselect Element Name

ETABLE,DispX,U,X
ETABLE,DispY,U,Y
ETABLE,DispZ,U,Z

PRETAB,DispX,DispY,DispZ
!PRETAB,DispY,DispZ

*ENDDO

/OUTPUT,
FINI
ALLSEL
!/EOF

```

APPENDIX

APPENDIX E

Ramberg-Osgood Stress-Strain Curve For Base Material

Reference: Mechanics of Offshore Pipeline: Buckling and Collapse, Vol. 1

Given parameters:

Youngs Modulus:	E := 207GPa	
Yield Stress:	SMYS := 450MPa	
Tensile Stress:	SMTS := 535MPa	
Elongation at break:	Δl_{break} := 20%	

Known points on the stress-strain curve:

Yield point:	$\sigma_y := \text{SMYS} = 450 \cdot \text{MPa}$	$\epsilon_y := 0.5\%$
Second point:	$\sigma_2 := \text{SMTS} = 535 \cdot \text{MPa}$	$\epsilon_2 := 9\%$

Ramberg-Osgood material model:

$$\epsilon(\sigma) = \frac{\sigma}{E} \cdot \left[1 + \frac{3}{7} \cdot \left(\frac{\sigma}{\sigma_{0.7}} \right)^{n-1} \right]$$

$$\sigma_{1y} := 480 \cdot \text{MPa}$$

$$\sigma_{12} := 555 \text{MPa}$$

$$\epsilon l(\sigma) = \frac{\sigma}{E} \cdot \left[1 + \frac{3}{7} \cdot \left(\frac{\sigma}{\sigma_{0.7}} \right)^{n-1} \right]$$

Calculating the Ramberg-Osgood curve parameters

The $\sigma_{0.7}$ is also called the Ramberg-Osgood yield parameter, and is sometimes denoted σ_R or σ_y . It is found by drawing a line in the stress-strain graph with a slope of $0.7E$ from origin. The Ramberg-Osgood yield parameter is the corresponding stress where this line intersects the stress-strain curve.

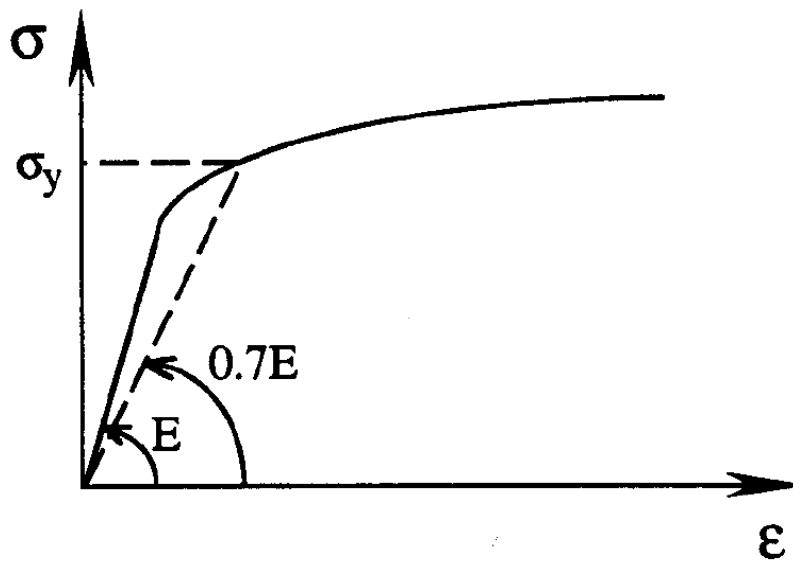

Re-arranging equation:

$$\varepsilon = \frac{\sigma}{E} \left[1 + \frac{3}{7} \cdot \left(\frac{\sigma}{\sigma_{0.7}} \right)^{n-1} \right]$$

$$\varepsilon \cdot E = \sigma + \frac{3}{7} \cdot \sigma \cdot \left(\frac{\sigma}{\sigma_{0.7}} \right)^{n-1}$$

$$\varepsilon \cdot E = \sigma + \frac{3}{7} \cdot \frac{\sigma^n}{\sigma_{0.7}^{n-1}}$$

$$\varepsilon \cdot E - \sigma = \frac{3}{7} \cdot \frac{\sigma^n}{\sigma_{0.7}^{n-1}}$$

$$\sigma_{0.7}^{n-1} = \frac{3}{7} \cdot \frac{\sigma^n}{\varepsilon \cdot E - \sigma}$$

Since $\sigma_{0.7}$ and n are constants, the following can be used:

$$\sigma_{0.7_1}^{n_1-1} = \sigma_{0.7_2}^{n_2-1} \quad \text{because} \quad \sigma_{0.7_1} = \sigma_{0.7_2} \quad \text{and} \quad n_1 = n_2$$

Hence:

$$\frac{3}{7} \cdot \frac{\sigma_1^n}{\varepsilon_1 \cdot E - \sigma_1} = \frac{3}{7} \cdot \frac{\sigma_2^n}{\varepsilon_2 \cdot E - \sigma_2} \quad \frac{3}{7} \text{ is cancelled, thus:}$$

$$\frac{\sigma_1^n}{\sigma_2^n} = \frac{\varepsilon_1 \cdot E - \sigma_1}{\varepsilon_2 \cdot E - \sigma_2} \quad \text{or} \quad \left(\frac{\sigma_1}{\sigma_2}\right)^n = \frac{\varepsilon_1 \cdot E - \sigma_1}{\varepsilon_2 \cdot E - \sigma_2}$$

Further:

$$\ln\left[\left(\frac{\sigma_1}{\sigma_2}\right)^n\right] = n \cdot \ln\left(\frac{\sigma_1}{\sigma_2}\right) = \ln\left(\frac{\varepsilon_1 \cdot E - \sigma_1}{\varepsilon_2 \cdot E - \sigma_2}\right)$$

Hence:

$$n(\sigma_1, \varepsilon_1, \sigma_2, \varepsilon_2) := \frac{\ln\left(\frac{\varepsilon_1 \cdot E - \sigma_1}{\varepsilon_2 \cdot E - \sigma_2}\right)}{\ln\left(\frac{\sigma_1}{\sigma_2}\right)}$$

Hence:

$$n_1(\sigma_1, \varepsilon_1, \sigma_2, \varepsilon_2) := \frac{\ln\left(\frac{\varepsilon_1 \cdot E - \sigma_1}{\varepsilon_2 \cdot E - \sigma_2}\right)}{\ln\left(\frac{\sigma_1}{\sigma_2}\right)}$$

And:

$$E1 := \frac{E}{\text{MPa}}$$

$$E1 = 2.07 \times 10^5$$

Remove unit for the calculation

$$\sigma_{0.7}(\sigma_x, \varepsilon_x, n) := \left(\frac{3}{7} \cdot \frac{\sigma_x^n}{\varepsilon_x \cdot E1 - \sigma_x}\right)^{\frac{1}{n-1}}$$

Which is true for any σ and corresponding ε .

For the current case:

$$n := n(\sigma_y, \varepsilon_y, \sigma_2, \varepsilon_2) \quad n = 19.835$$

$$n_1 := n_1(\sigma_{1y}, \varepsilon_y, \sigma_{12}, \varepsilon_2)$$

$$\sigma_{0.7} := \sigma_{0.7} \left(\frac{\sigma_y}{1 \text{ MPa}}, \epsilon_y, n \right) \cdot 1 \text{ MPa} \quad \sigma_{0.7} = 424.254 \cdot \text{MPa}$$

Repeating expression, required for graphing

$$\epsilon(\sigma) := \frac{\sigma}{E} \left[1 + \frac{3}{7} \cdot \left(\frac{\sigma}{\sigma_{0.7}} \right)^{n-1} \right]$$

σ solve $\rightarrow 0$

$$\epsilon_1(\sigma) := \frac{\sigma}{E} \left[1 + \frac{3}{7} \cdot \left(\frac{\sigma}{\sigma_{0.7}} \right)^{n_1-1} \right]$$

Setting plot range:

$$\sigma := 0 \text{ MPa}, 10 \text{ MPa} \dots \sigma_2$$

Ramberg-Osgood curve:

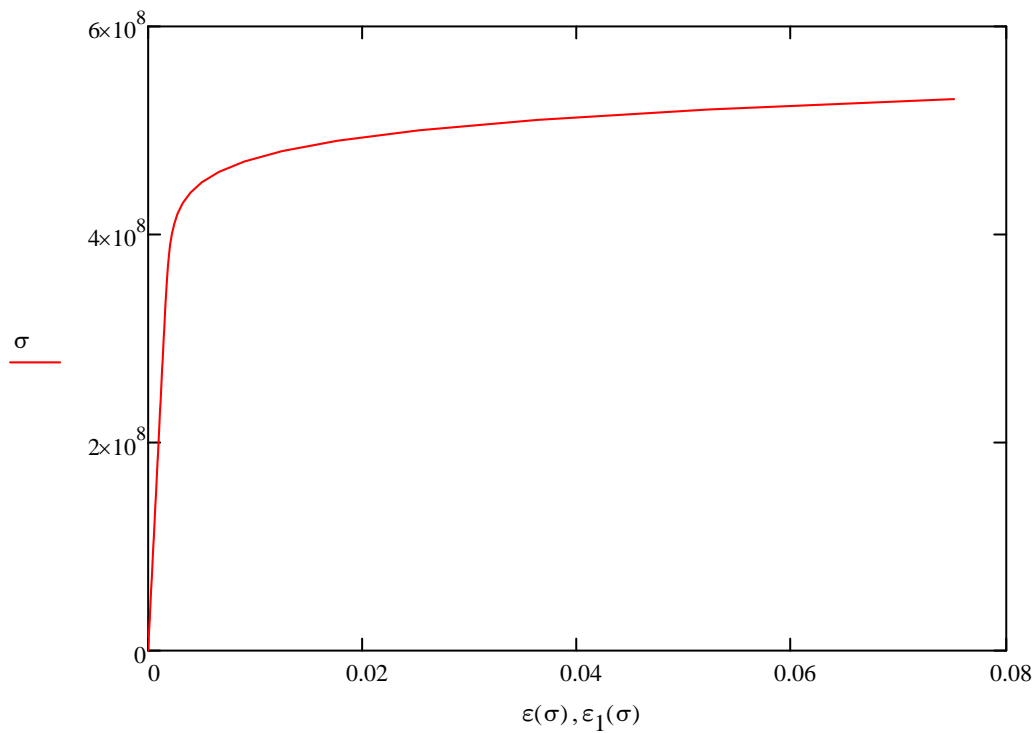

Ramber-Osgood Stress-Strain Curve For De-rated Material

Reference: Mechanics of Offshore Pipeline: Buckling and Collapse, Vol. 1

Given parameters:

Youngs Modulus:	$E := 207\text{GPa}$
Yield Stress:	$\text{SMYS} := 423\text{MPa}$
Tensile Stress:	$\text{SMTS} := 508\text{MPa}$
Elongation at break:	$\Delta l_{\text{break}} := 20\%$

Known points on the stress-strain curve:

Yield point:	$\sigma_y := \text{SMYS} = 423\text{MPa}$	$\epsilon_y := 0.5\%$
Second point:	$\sigma_2 := \text{SMTS} = 508\text{MPa}$	$\epsilon_2 := 9\%$

Ramber-Osgood material model:

$$\epsilon(\sigma) = \frac{\sigma}{E} \left[1 + \frac{3}{7} \cdot \left(\frac{\sigma}{\sigma_{0.7}} \right)^{n-1} \right]$$

$$\sigma_{1y} := 480\text{MPa}$$

$$\sigma_{12} := 555\text{MPa}$$

$$\epsilon_1(\sigma) = \frac{\sigma}{E} \left[1 + \frac{3}{7} \cdot \left(\frac{\sigma}{\sigma_{0.7}} \right)^{n-1} \right]$$

Calculating the Ramberg-Osgood curve parameters

The $\sigma_{0.7}$ is also called the Ramberg-Osgood yield parameter, and is sometimes denoted σ_R or σ_y . It is found by drawing a line in the stress-strain graph with a slope of $0.7E$ from origin. The Ramberg-Osgood yield parameter is the corresponding stress where this line intersects the stress-strain curve.

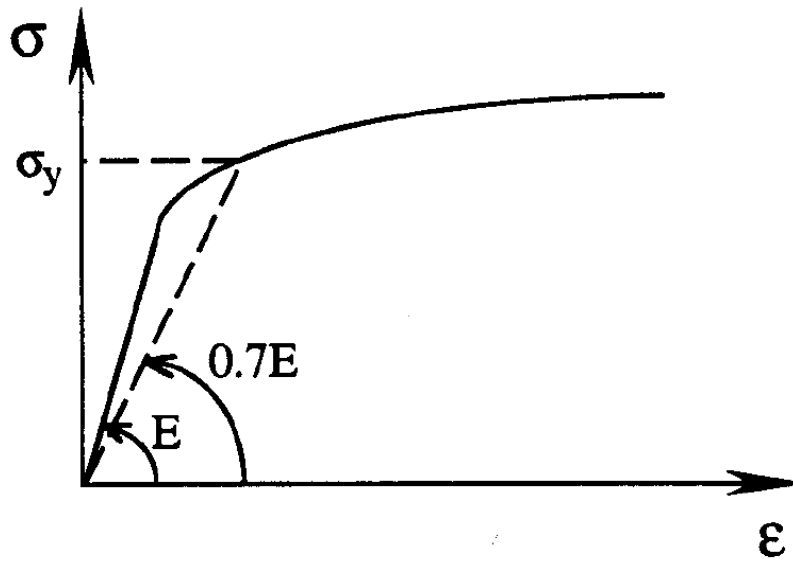

Re-arranging equation:

$$\varepsilon = \frac{\sigma}{E} \left[1 + \frac{3}{7} \cdot \left(\frac{\sigma}{\sigma_{0.7}} \right)^{n-1} \right]$$

$$\varepsilon \cdot E = \sigma + \frac{3}{7} \cdot \sigma \cdot \left(\frac{\sigma}{\sigma_{0.7}} \right)^{n-1}$$

$$\varepsilon \cdot E = \sigma + \frac{3}{7} \cdot \frac{\sigma^n}{\sigma_{0.7}^{n-1}}$$

$$\varepsilon \cdot E - \sigma = \frac{3}{7} \cdot \frac{\sigma^n}{\sigma_{0.7}^{n-1}}$$

$$\sigma_{0.7}^{n-1} = \frac{3}{7} \cdot \frac{\sigma^n}{\varepsilon \cdot E - \sigma}$$

Since $\sigma_{0.7}$ and n are constants, the following can be used:

$$\sigma_{0.7_1}^{n_1-1} = \sigma_{0.7_2}^{n_2-1} \quad \text{because} \quad \sigma_{0.7_1} = \sigma_{0.7_2} \quad \text{and} \quad n_1 = n_2$$

Hence:

$$\frac{3}{7} \cdot \frac{\sigma_1^n}{\varepsilon_1 \cdot E - \sigma_1} = \frac{3}{7} \cdot \frac{\sigma_2^n}{\varepsilon_2 \cdot E - \sigma_2} \quad \frac{3}{7} \text{ is cancelled, thus:}$$

$$\frac{\sigma_1^n}{\sigma_2^n} = \frac{\varepsilon_1 \cdot E - \sigma_1}{\varepsilon_2 \cdot E - \sigma_2} \quad \text{or} \quad \left(\frac{\sigma_1}{\sigma_2}\right)^n = \frac{\varepsilon_1 \cdot E - \sigma_1}{\varepsilon_2 \cdot E - \sigma_2}$$

Further:

$$\ln\left[\left(\frac{\sigma_1}{\sigma_2}\right)^n\right] = n \cdot \ln\left(\frac{\sigma_1}{\sigma_2}\right) = \ln\left(\frac{\varepsilon_1 \cdot E - \sigma_1}{\varepsilon_2 \cdot E - \sigma_2}\right)$$

Hence:

$$n(\sigma_1, \varepsilon_1, \sigma_2, \varepsilon_2) := \frac{\ln\left(\frac{\varepsilon_1 \cdot E - \sigma_1}{\varepsilon_2 \cdot E - \sigma_2}\right)}{\ln\left(\frac{\sigma_1}{\sigma_2}\right)}$$

Hence:

$$n_1(\sigma_1, \varepsilon_1, \sigma_2, \varepsilon_2) := \frac{\ln\left(\frac{\varepsilon_1 \cdot E - \sigma_1}{\varepsilon_2 \cdot E - \sigma_2}\right)}{\ln\left(\frac{\sigma_1}{\sigma_2}\right)}$$

And:

$$E1 := \frac{E}{\text{MPa}}$$

$$E1 = 2.07 \times 10^5$$

Remove unit for the calculation

$$\sigma_{0.7}(\sigma_x, \varepsilon_x, n) := \left(\frac{3}{7} \cdot \frac{\sigma_x^n}{\varepsilon_x \cdot E1 - \sigma_x}\right)^{\frac{1}{n-1}}$$

Which is true for any σ and corresponding ε .

For the current case:

$$n := n(\sigma_y, \varepsilon_y, \sigma_2, \varepsilon_2) \quad n = 18.503$$

$$n_1 := n_1(\sigma_{1y}, \varepsilon_y, \sigma_{12}, \varepsilon_2)$$

$$\sigma_{0.7} := \sigma_{0.7} \left(\frac{\sigma_y}{1 \text{ MPa}}, \epsilon_y, n \right) \cdot 1 \text{ MPa} \quad \sigma_{0.7} = 394.596 \cdot \text{MPa}$$

Repeating expression, required for graphing

$$\epsilon(\sigma) := \frac{\sigma}{E} \left[1 + \frac{3}{7} \cdot \left(\frac{\sigma}{\sigma_{0.7}} \right)^{n-1} \right]$$

σ solve $\rightarrow 0$

$$\epsilon_1(\sigma) := \frac{\sigma}{E} \left[1 + \frac{3}{7} \cdot \left(\frac{\sigma}{\sigma_{0.7}} \right)^{n_1-1} \right]$$

Setting plot range:

$$\sigma := 0 \text{ MPa}, 10 \text{ MPa} \dots \sigma_2$$

Ramberg-Osgood curve:

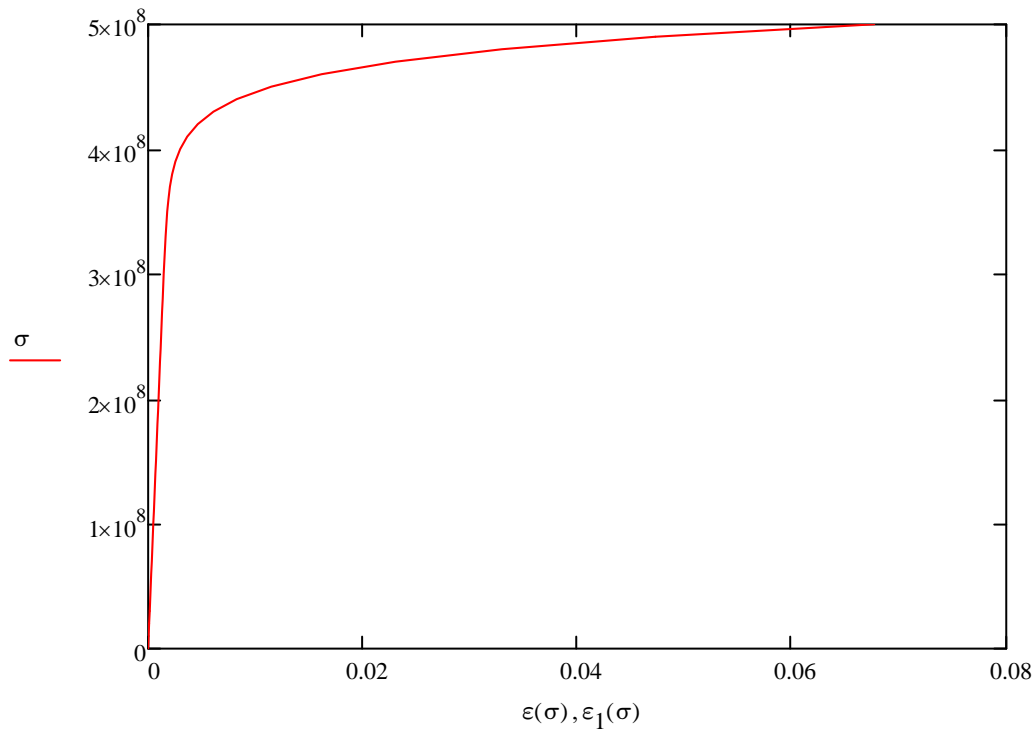

APPENDIX F

Trawl pull-over with Clump Weights*Input section:*Clump weight data:

$$L_{\text{Clump_roller}} := 0.70 \cdot \text{m} \quad m_t := 9000 \cdot \text{kg} \quad (\text{steel mass})$$

$$V_{\text{trawl}} := 2.8 \cdot \frac{\text{m}}{\text{s}}$$

Pipe data:

$$\text{OD} := 0.43 \cdot \text{m} \quad (\text{including coating})$$

Other input data:

$$H_{\text{sp}} := 0 \cdot \text{m} \quad (\text{span height}) \quad g = 9.807 \frac{\text{m}}{\text{s}^2} \quad \text{WD} := 300 \cdot \text{m} \quad \delta_p := 0.3 \cdot \text{m} \quad (\text{trawl deflection})$$

Calculations:

$$h := \frac{(H_{\text{sp}} + \text{OD})}{L_{\text{Clump_roller}}} \quad h = 0.614 \quad (\text{Dimensionless height})$$

$$\text{Parm} := \frac{\text{OD}}{L_{\text{Clump_roller}}} \quad \text{Parm} = 0.614$$

$$F_p := 3.9 \cdot m_t \cdot g \cdot \left[1 - e^{(-1.8 \cdot h)} \right] \cdot \text{Parm}^{-0.65} \quad F_p = 3.161 \times 10^5 \text{ N} \quad (\text{Horizontal force})$$

$$F_{Z_up} := 0.3 \cdot F_p - 0.4 \cdot m_t \cdot g \quad F_{Z_up} = 5.953 \times 10^4 \text{ N} \quad (\text{upward force})$$

$$F_{Z_down} := 0.1 \cdot F_p - 1.1 \cdot m_t \cdot g \quad F_{Z_down} = -6.548 \times 10^4 \text{ N} \quad (\text{downward force})$$

$$L_w := 3 \cdot \text{WD}$$

$$k_w := \frac{3.5 \cdot 10^7 \cdot \text{N}}{L_w} \quad k_w = 3.889 \times 10^4 \frac{\text{kg}}{\text{s}^2}$$

$$T_p := \left(\frac{F_p}{k_w \cdot V_{\text{trawl}}} \right) + \frac{\delta_p}{V_{\text{trawl}}} \quad T_p = 3.01 \text{ s} \quad (\text{Duration})$$

$$T_1 := 0.2\text{s}$$

$$T_2 := T_p - 0.6\text{s}$$

$$T_2 = 2.41\text{s}$$

$$t := \begin{pmatrix} 0 \\ T_1 \\ T_2 \\ T_p \end{pmatrix} \quad F_{\text{hor}} := \begin{pmatrix} 0 \\ 0.5 \cdot F_p \\ F_p \\ 0 \end{pmatrix} \quad F_{\text{up}} := \begin{pmatrix} 0 \\ 0.5 \cdot F_{Z_{\text{up}}} \\ F_{Z_{\text{up}}} \\ 0 \end{pmatrix} \quad F_{\text{down}} := \begin{pmatrix} 0 \\ 0.5 \cdot F_{Z_{\text{down}}} \\ F_{Z_{\text{down}}} \\ 0 \end{pmatrix}$$

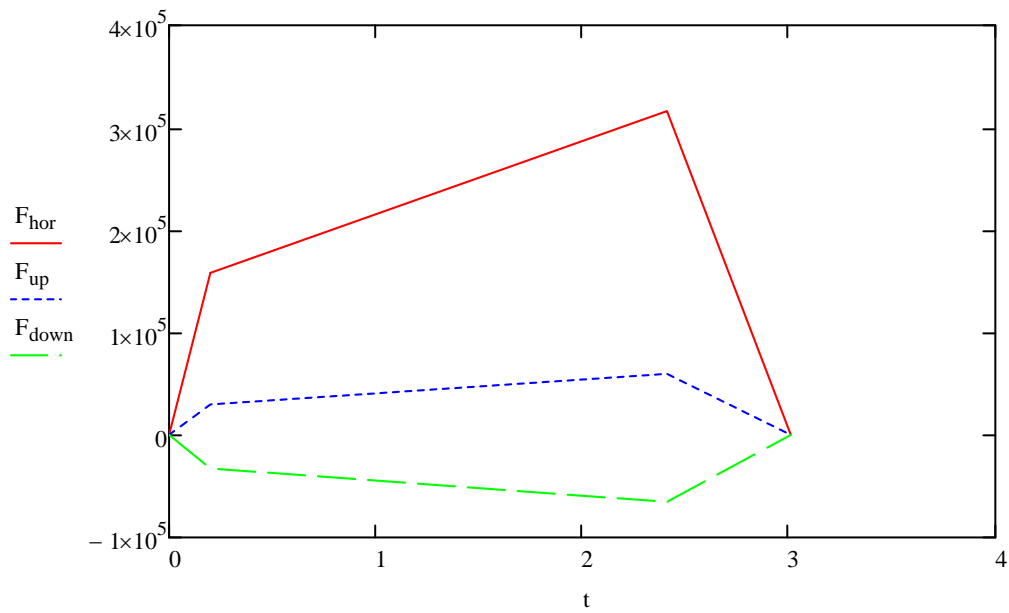

$$t = \begin{pmatrix} 0 \\ 0.2 \\ 2.41 \\ 3.01 \end{pmatrix} \text{s} \quad F_{\text{hor}} = \begin{pmatrix} 0 \\ 1.581 \times 10^5 \\ 3.161 \times 10^5 \\ 0 \end{pmatrix} \text{N} \quad F_{\text{up}} = \begin{pmatrix} 0 \\ 2.976 \times 10^4 \\ 5.953 \times 10^4 \\ 0 \end{pmatrix} \text{N} \quad F_{\text{down}} = \begin{pmatrix} 0 \\ -3.274 \times 10^4 \\ -6.548 \times 10^4 \\ 0 \end{pmatrix} \text{N}$$

APPENDIX G



DNV-OS-F101 and DNV-RP-F110 Structural checks of pipeline

1 - Input

Design moment	$M_{sd} := 0.15 \text{ kN}\cdot\text{m}$	
Design effective axial force	$S_{sd} := 500 \text{ kN}$	
Internal pressure	$p_{ip} := 150 \text{ bar}$	
External pressure	$p_{ep} := 80.44 \text{ bar}$	
Minimum internal pressure	$p_{min} := 0 \text{ bar}$	
Yield strength	$R_{t05} := 450 \text{ MPa}$	
Tensile strength	$R_m := 535 \text{ MPa}$	
Strain at yield strength point	$\epsilon_{rt05} := 0.005$	
Strain at tensile strength limit	$\epsilon_{rm} := 0.180$	
Outer diameter of pipe	$D := 559 \text{ mm}$	
Wall thickness of pipe	$t_w := 19.1 \text{ mm}$	
Corrosion allowance	$t_{corr} := 0 \text{ mm}$	
Specified minimum yield strength	$SMYS := 423 \text{ MPa}$	at 95degC derating
Specified minimum tensile strength	$SMTS := 508 \text{ MPa}$	at 100degC derating
Young's modulus	$E := 207000 \text{ MPa}$	
Functional load factor	$\gamma_f := 1.1$	
Safety class resistance factors	$\gamma_{sc} := 1.14$	
Seabed condition factor	$\gamma_c := 0.80$	
Pressure load factor (OS-F101 - 2000)	$\gamma_{pr} := 1.05$	
Material resistance factor	$\gamma_m := 1.15$	
Material reduction factor	$\alpha_u := 0.96$	
Resistance strain factor	$\gamma_e := 2.5$	
Axial strain resistance factor	$\gamma_{ax} := 3.5$	
Concrete strain intention factor	$\gamma_{cc} := 1.25$	

2 - Load controlled combined buckling check in accordance with DNV-OS-F101 - 2007

Design wall thickness

$$t := t_w - t_{corr} = 19.1 \cdot \text{mm}$$

Design internal pressure

$$p_i := p_{ip} = 150 \cdot \text{bar}$$

$$p_e := p_{ep} = 80.44 \cdot \text{bar}$$

$$\text{loadcheck} := \begin{cases} \text{"The combined loading buckling criterion is applicable"} & \text{if } \frac{D}{t} \leq 45 \wedge p_{ip} > p_{ep} \\ \text{"The combined loading buckling criterion is not applicable"} & \text{otherwise} \end{cases}$$

$$\text{loadcheck} = \text{"The combined loading buckling criterion is applicable"}$$



Design yield stress:

$$f_y := \text{SMYS} \cdot \alpha_u = 406.08 \cdot \text{MPa}$$

Design tensile stress:

$$f_u := \text{SMTS} \cdot \alpha_u = 487.68 \cdot \text{MPa}$$

The pressure containment resistance

$$f_{cb} := \min\left(f_y, \frac{f_u}{1.15}\right) = 406.08 \cdot \text{MPa}$$

$$p_b := \frac{2 \cdot t}{D - t} \cdot f_{cb} \cdot \frac{2}{\sqrt{3}} = 33.2 \cdot \text{MPa}$$

Plastic capacities for a pipe

$$S_p := f_y \cdot \pi \cdot (D - t) \cdot t = 13155.5 \cdot \text{kN}$$

$$M_p := f_y \cdot (D - t)^2 \cdot t = 2260.8 \cdot \text{kN} \cdot \text{m}$$

Normalised moment

$$M_{sdn} := \frac{M_{sd} \cdot \gamma_f \cdot \gamma_c}{M_p} = 0.0001$$

Normalised effective force

$$S_{dn} := \frac{S_{sd} \cdot \gamma_f \cdot \gamma_c}{S_p} = 0.0334$$

Normalised pressure

$$q_h := \frac{p_i}{p_b \cdot \frac{2}{\sqrt{3}}} = 0.392$$

$$\beta := \begin{cases} 0.5 & \text{if } \frac{D}{t} < 15 \\ \frac{60 - \frac{D}{t}}{90} & \text{if } 15 \leq \frac{D}{t} \leq 60 \\ 0 & \text{if } \frac{D}{t} > 60 \end{cases} = 0.34$$

$$\alpha_p := \begin{cases} 1 - \beta & \text{if } \frac{p_i - p_e}{p_b} < \frac{2}{3} \\ 1 - 3 \cdot \beta \cdot \left(1 - \frac{p_i - p_e}{p_b}\right) & \text{if } \frac{p_i - p_e}{p_b} \geq \frac{2}{3} \end{cases} = 0.659$$

$$\alpha_c := (1 - \beta) + \beta \cdot \frac{f_u}{f_y} = 1.069$$



Utilisation in accordance with DNV-OS-F101 - 2007

$$UF1 := \left[\gamma_m \cdot \gamma_{sc} \cdot \frac{|M_{sd} \cdot \gamma_f \cdot \gamma_c|}{\alpha_c \cdot M_p} + \left(\frac{\gamma_m \cdot \gamma_{sc} \cdot \gamma_f \cdot \gamma_c \cdot S_{sd}}{\alpha_c \cdot S_p} \right)^2 \right]^2 + \left(\alpha_p \cdot \frac{p_i - p_e}{\alpha_c \cdot p_b} \right)^2 = 0.017$$

$$UF2 := \left[\gamma_m \cdot \gamma_{sc} \cdot \frac{|M_{sdn}|}{\alpha_c} + \left(\frac{\gamma_m \cdot \gamma_{sc} \cdot S_{dn}}{\alpha_c} \right)^2 \right]^2 + \left(\alpha_p \cdot \frac{p_i - p_e}{\alpha_c \cdot p_b} \right)^2 = 0.017$$

Maximum allowable moment:

$$M_{bsmax} := \left[\frac{\alpha_c}{\gamma_m \cdot \gamma_{sc}} \cdot \sqrt{1 - \left(\alpha_p \cdot \frac{p_i - p_e}{\alpha_c \cdot p_b} \right)^2} - \frac{\gamma_m \cdot \gamma_{sc} \cdot S_{dn}^2}{\alpha_c} \right] \cdot M_p \cdot \frac{1}{\gamma_f \cdot \gamma_c} = 2073.1 \cdot \text{kN} \cdot \text{m}$$

DNV-OS-F101 and DNV-RP-F110 Structural checks of pipeline 1 - Input

Design moment	$M_{sd} := 0.15 \text{ kN}\cdot\text{m}$	
Design effective axial force	$S_{sd} := -15 \text{ kN}$	
Internal pressure	$p_{ip} := 150 \text{ bar}$	
External pressure	$p_{ep} := 0 \text{ bar}$	
Minimum internal pressure	$p_{min} := 0 \text{ bar}$	
Yield strength	$R_{t05} := 450 \text{ MPa}$	
Tensile strength	$R_m := 535 \text{ MPa}$	
Strain a yield strength point	$\epsilon_{rt05} := 0.005$	
Strain at tensile strength limit	$\epsilon_{rm} := 0.180$	
Outer diameter of pipe	$D := 559 \text{ mm}$	
Wall thickness of pipe	$t_w := 19.1 \text{ mm}$	
Corrosion allowance	$t_{corr} := 5 \text{ mm}$	
Specified minimum yield strength	$SMYS := 423 \text{ MPa}$	at 95degC derating
Specified minimum tensile strength	$SMTS := 508 \text{ MPa}$	at 95degC derating
Young's modulus	$E := 207000 \text{ MPa}$	
Functional load factor	$\gamma_f := 1.1$	
Safety class resistance factors	$\gamma_{sc} := 1.14$	
Seabed condition factor	$\gamma_c := 0.80$	
Pressure load factor (OS-F101 - 2000)	$\gamma_{pr} := 1.05$	
Material resistance factor	$\gamma_m := 1.15$	
Material reduction factor	$\alpha_u := 0.96$	
Resistance strain factor	$\gamma_e := 2.5$	
Axial strain resistance factor	$\gamma_{ax} := 3.5$	
Concrete strain intention factor	$\gamma_{cc} := 1.25$	
Corrosion resistance factor	$R_f := 0.570$	

2 - Load controlled combined buckling check in accordance with DNV-OS-F101 - 2007

Design wall thickness

$$t := t_w - t_{corr} = 14.1 \text{ mm}$$

Design internal pressure

$$p_i := p_{ip} = 150 \text{ bar}$$

$$p_e := p_{ep} = 0 \text{ bar}$$

$$\text{loadcheck} := \begin{cases} \text{"The combined loading buckling criterion is applicable"} & \text{if } \frac{D}{t} \leq 45 \wedge p_{ip} > p_{ep} \\ \text{"The combined loading buckling criterion is not applicable"} & \text{otherwise} \end{cases}$$

$$\text{loadcheck} = \text{"The combined loading buckling criterion is applicable"}$$

Design yield stress:

$$f_y := \text{SMYS} \cdot \alpha_u = 406.08 \cdot \text{MPa}$$

Design tensile stress:

$$f_u := \text{SMTS} \cdot \alpha_u = 487.68 \cdot \text{MPa}$$

The pressure containment resistance

$$f_{cb} := \min\left(f_y, \frac{f_u}{1.15}\right) = 406.08 \cdot \text{MPa}$$

$$p_b := \frac{2 \cdot t}{D - t} \cdot f_{cb} \cdot \frac{2}{\sqrt{3}} = 24.3 \cdot \text{MPa}$$

Plastic capacities for a pipe

$$S_p := f_y \cdot \pi \cdot (D - t) \cdot t = 9801.6 \cdot \text{kN}$$

$$M_p := f_y \cdot (D - t)^2 \cdot t = 1700.1 \cdot \text{kN} \cdot \text{m}$$

Normalised moment

$$M_{sdn} := \frac{M_{sd} \cdot \gamma_f \cdot \gamma_c}{M_p} = 0.0001$$

Normalised effective force

$$S_{dn} := \frac{S_{sd} \cdot \gamma_f \cdot \gamma_c}{S_p} = -0.0013$$

Normalised pressure

$$q_h := \frac{p_i}{p_b \cdot \frac{2}{\sqrt{3}}} = 0.535$$

$$\beta := \begin{cases} 0.5 & \text{if } \frac{D}{t} < 15 \\ \frac{60 - \frac{D}{t}}{90} & \text{if } 15 \leq \frac{D}{t} \leq 60 \\ 0 & \text{if } \frac{D}{t} > 60 \end{cases} = 0.23$$

$$\alpha_p := \begin{cases} 1 - \beta & \text{if } \frac{p_i - p_e}{p_b} < \frac{2}{3} \\ 1 - 3 \cdot \beta \cdot \left(1 - \frac{p_i - p_e}{p_b}\right) & \text{if } \frac{p_i - p_e}{p_b} \geq \frac{2}{3} \end{cases} = 0.774$$

$$\alpha_c := (1 - \beta) + \beta \cdot \frac{f_u}{f_y} = 1.045$$

Utilisation in accordance with DNV-OS-F101 - 2007

$$UF1 := \left[\gamma_m \cdot \gamma_{sc} \cdot \frac{|M_{sd} \cdot \gamma_f \cdot \gamma_c|}{\alpha_c \cdot M_p} + \left(\frac{\gamma_m \cdot \gamma_{sc} \cdot \gamma_f \cdot \gamma_c \cdot S_{sd}}{\alpha_c \cdot S_p} \right)^2 \right]^2 + \left(\alpha_p \cdot \frac{p_i - p_e}{\alpha_c \cdot p_b} \right)^2 = 0.209$$

$$UF2 := \left[\gamma_m \cdot \gamma_{sc} \cdot \frac{|M_{sdn}|}{\alpha_c} + \left(\frac{\gamma_m \cdot \gamma_{sc} \cdot S_{dn}}{\alpha_c} \right)^2 \right]^2 + \left(\alpha_p \cdot \frac{p_i - p_e}{\alpha_c \cdot p_b} \right)^2 = 0.209$$

Maximum allowable moment:

$$M_{bsmax} := \left[\frac{\alpha_c}{\gamma_m \cdot \gamma_{sc}} \cdot \sqrt{1 - \left(\alpha_p \cdot \frac{p_i - p_e}{\alpha_c \cdot p_b} \right)^2} - \frac{\gamma_m \cdot \gamma_{sc} \cdot S_{dn}^2}{\alpha_c} \right] \cdot M_p \cdot \frac{1}{\gamma_f \cdot \gamma_c} = 1369.9 \cdot \text{kN} \cdot \text{m}$$

2 - Displacement controlled combined buckling check in accordance with DNV-OS-F101

$$\text{cloaddischeck} := \begin{cases} \text{"The displ. contr. buckling criterion is applicable"} & \text{if } \frac{D}{t} \leq 45 \wedge p_{ip} > p_{ep} \\ \text{"The displ. contr. buckling criterion is not applicable"} & \text{otherwise} \end{cases}$$

cloaddischeck = "The displ. contr. buckling criterion is applicable"

Yield strength / tensile strength ratio:

$$\alpha_h := \frac{R_{t05}}{R_m} = 0.841$$

Girth weld factor:

$$\alpha_{gw} := \begin{cases} 1 & \text{if } \frac{D}{t} \leq 20 \\ 1 - \left(\frac{D}{t} - 20 \right) \cdot 0.01 & \text{if } 20 < \frac{D}{t} < 60 \\ 0.6 & \text{otherwise} \end{cases} = 0.804$$

Design compressive strain - pi > pe:

$$\epsilon_c := 0.78 \cdot \left(\frac{t}{D} - 0.01 \right) \cdot \left(1 + 5.75 \cdot \frac{p_{min} - p_e}{p_b} \right) \cdot \alpha_h^{-1.5} \cdot \alpha_{gw} = 0.0124$$

$$\epsilon_{sd} := \frac{\epsilon_c}{\gamma_e \cdot \gamma_{cc}} = 0.004$$