

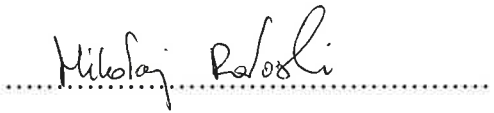

University of  
Stavanger

Faculty of Science and Technology

## MASTER'S THESIS

Study program/ Specialization: MSc Petroleum Engineering / Exchange Programme	Spring semester, 2016 Open
Writer: Mikołaj Rałowski	 (Writer's signature)
Faculty supervisor: Prof. Jann Rune Ursin External supervisor(s): Steinar Bryne	
Title of thesis: <b>Design of a hypothetical relief well for a shallow reservoir, possible challenges.</b>	
Credits (ECTS): 30	
Keywords: Relief well, blowout, trajectory, location, intersection, design, casing, challenges, shallow reservoir	Pages: 78 + enclosure: 6 Stavanger, May, 2016. Date/year

## Abstract

Blowouts are one of the biggest threats during exploration and production of oil and gas. Losing control of a well can lead to severe consequences both economically, environmentally and put the working crew in danger. There are several blowout contingency methods which allow to regain control of the well. Last resort method is to drill one or more relief wells, intersect with the blowing well and perform a dynamic kill procedure. While relief well drilling and killing a blowing well through it is a quite well-developed concept, there are some scenarios that require a different approach.

Such scenario would be when the reservoir lays very shallow below the seabed. In that case, regardless whether it is an appraisal well or producer that gets the blowout, it cannot be killed through a relief well of usual S-shaped trajectory because the depth is too small to drill such well. Such situation requires a novel relief well design approach and needs to be addressed.

In this Thesis, a real-life shallow reservoir scenario located on a Barents Sea has been presented and carefully evaluated. For this scenario, 2 relief well surface locations have been chosen and a novel, U-shaped relief well trajectory has been proposed. The trajectory has been calculated and the entire situation has been presented in modelling software such as 3Ddrill and Landmark COMPASS. Later, casing design for the relief well has been proposed based on already existing concept of a horizontal well designed for this particular location.

Possible challenges associated with such relief well trajectory design have been presented and discussed. The U-shaped relief well will suffer from several obstacles that would need to be overcome, such as difficulties in cuttings transport or reduced Weight on Bit due to well friction and high well inclination. As the process of localizing, tracking and intersection will differ strongly from the typical approach in S-shaped relief wells, potential challenges will also may occur on that stage. For some of those difficulties, potential solutions have been proposed and discussed. Relief well should be drilled with Rotary Steerable System. Process of localizing and tracking could be performed with the use of such technologies as Casing Premagnetization and Surface Seismic While Drilling. To design the intersection, the approach utilized on Montara Blowout can be used. The blowing well can be bypassed, its casing can then be located and the intersection could happen in following approaches from sidetracks.

The design proposed in this Thesis is only a concept and to prove its feasibility further development is needed. Recommendations for future work include modelling of the drilling process, for example torque & drag calculations or drilling parameters calculations. Also, if the geological scenario is available, detailed casing design could be calculated and proposed. Dynamic kill procedure modelling with such tools as OLGA Software would be also a very interesting topic to cover.

## Table of Contents

Abstract .....	2
List of Figures .....	5
List of Tables.....	6
Nomenclature .....	7
Acknowledgements .....	8
1 Chapter I – Introduction – Overview of the Topic .....	9
1.1 Structure of the Thesis.....	9
2 Chapter II – Theory .....	10
2.1 Blowout .....	10
2.1.1 Causes of a kick.....	11
2.1.2 Types of blowout.....	13
2.1.3 Blowout kill & control.....	13
2.2 Relief well .....	15
2.2.1 Relief well origins .....	15
2.2.2 Technology development .....	16
2.2.3 Relief well strategy today .....	18
2.2.4 Typical relief well trajectories, intersection methods, intersection point [13] .....	22
2.2.5 Subsea relief well surface location and rig placement drivers .....	25
2.2.6 Relief well design & planning process .....	27
2.3 Dynamic kill .....	28
3 Chapter III – Defining Thesis Problematics .....	30
4 Chapter IV – Subject of the Thesis.....	32
5 Chapter V – Scenario Evaluation .....	33
5.1 Well 7324/8-1 (Wisting Central).....	36
6 Chapter VI – Relief Well Design .....	40
6.1 Relief well location .....	40
6.1.1 Infrastructure/operations placement .....	40
6.1.2 Seafloor topography .....	42
6.1.3 Distance from the blowing well .....	42
6.1.4 Water depth .....	43
6.1.5 Shallow dangers .....	43
6.1.6 Marine/meteorological data.....	45
6.1.7 Relief well location.....	47
6.2 Relief well trajectory .....	48
6.2.1 Intersection point.....	48

6.2.2	Dogleg Severity (DLS).....	48
6.2.3	Inclination.....	49
6.2.4	Trajectory proposition .....	49
6.2.5	Trajectory calculations .....	51
6.3	Casing design .....	57
6.3.1	Conductor .....	58
6.3.2	Surface casing.....	59
6.3.3	Intermediate casing.....	60
6.3.4	Liner .....	61
7	Chapter VII – Discussion – Possible Challenges .....	65
7.1	Shallow conductor and surface casing placement .....	65
7.2	High dogleg severity (DLS) .....	66
7.3	Cuttings transport .....	67
7.4	Lower Weight on Bit (WOB), increased friction .....	68
7.5	Drilling equipment, Directional control, Geosteering .....	69
7.6	Tracking & localization.....	70
7.7	Homing-in & intersection.....	71
8	Chapter VIII – Summary, Conclusion.....	72
9	Chapter IX – Future Work.....	74
10	Chapter X – References.....	75
11	Chapter XI – Appendixes .....	79
11.1	Appendix 1 – Derivation of geometrical formulas for trajectory calculations .....	79
11.2	Appendix 2 – Relief well planning table.....	81

## List of Figures

Figure 1 - Deepwater Horizon Platform sinking. [2].....	10
Figure 2 - Surface blowout on a drilling rig. [3] .....	11
Figure 3 - Relief Well in Conroe, Texas, 1933. [7].....	15
Figure 4 - Relief well scheme. [9].....	19
Figure 5 – Electromagnetic casing detection scheme. [10] .....	19
Figure 6 - Relief well and blowing well intersection scheme. [11].....	20
Figure 7 - Typical relief well trajectory and pumping scheme. [12].....	21
Figure 8 - Early relief well scheme. [13].....	22
Figure 9 - Simple interception scheme. [13] .....	22
Figure 10 - Parallel track intersection scheme. [13].....	23
Figure 11 - Oriented interception scheme. [13].....	23
Figure 12 - Relief well trajectory and interception approach. [13] .....	24
Figure 13 - Locating, tracking, orienting and interception phase. [13].....	25
Figure 14 – Distance from the blowing well scheme. ....	26
Figure 15 - Upwind location concept. [17] .....	26
Figure 16 - Dynamic kill procedure scheme. [21].....	29
Figure 17 - Relief wells for deep reservoir. [22] .....	30
Figure 18 - Shallow reservoir situation scheme. [23].....	31
Figure 19 - Well 7324/8-1 with schematic relief wells. [24].....	31
Figure 20 – Hypothetical relief well concept for a shallow reservoir. [25].....	33
Figure 21 - Production License 537 location with Wisting and Hanssen segments. [23][26] .....	34
Figure 22 - 3D resistivity anomalies of Wisting and Hanssen discoveries. [29].....	35
Figure 23 - Wet wildcat wells drilled on PL 537. [28].....	36
Figure 24 - Location of well 7324/8-1. [27].....	37
Figure 25 - Well 7324/8-1 profile. [28].....	37
Figure 26 - Possible 7324/8-1 well profile. ....	38
Figure 27 - Placement of subsea infrastructure nearby well 7324/8-1. [31] .....	41
Figure 28 - Map of marine traffic & operations nearby 7324/8-1 well. [32] .....	41
Figure 29 - Bathymetric map of seafloor topography around well 7324/8-1. [33] .....	42
Figure 30 - Distance from well 7324/8-1 with no-go zones.....	42
Figure 31 - Geophysical resistivity survey for considered location. [24].....	43
Figure 32 - Geophysical survey for considered location NW-SE. [35].....	44
Figure 33 - Geophysical survey of considered location W-E. [35] .....	44
Figure 34 - Wind direction map. [34].....	45
Figure 35 - Sea current map. [34].....	46

Figure 36 - Simulation of blowout and oil spill. [23].....	46
Figure 37 - Potential relief well locations. ....	47
Figure 38 - Build rates in horizontal wells. [36] .....	48
Figure 39 - Well inclination angle.....	49
Figure 40 - 2D vertical plan of relief well trajectory.....	50
Figure 41 - Relief well and 7324/8-1 well on 2D vertical plane. ....	50
Figure 42 - Relief well and well 7324/8-1 on 3D plane. ....	51
Figure 43 - Relief well trajectory with values. ....	51
Figure 44 - Relief well build section (2). ....	52
Figure 45 - Relief well straight, inclined section (3).....	53
Figure 46 - Relief well with lengths. ....	54
Figure 47 - Relief well deepest point. ....	54
Figure 48 - Relief well vertical section. ....	55
Figure 49 - Relief well trajectory summary. ....	56
Figure 50 - Horizontal well concept for Wisting Prospect by OMV Norge AS. [37].....	57
Figure 51 - Relief well casing scheme - conductor. ....	58
Figure 52 - Relief well casing scheme – surface casing.....	59
Figure 53 - Relief well casing scheme – intermediate casing. ....	60
Figure 54 - Relief well casing scheme - liner.....	61
Figure 55 - Relief well and 7324/8-1 well casing scheme. ....	63
Figure 56 - Relief well casing scheme - summary. ....	64
Figure 57 - Shallow conductor and surface casing placement. ....	65
Figure 58 - Potential problematic zones for cuttings transport. ....	67
Figure 59 - Bypass homing-in process scheme. ....	72

**List of Tables**

Table 1 - Schedule of exploration work on PL 537. [27].....	35
Table 2 - 7324/8-1 well construction sequence. [27] .....	39
Table 3 - Relief well trajectory summary.....	56
Table 4 - Relief well casing plan.....	62

## *Nomenclature*

BHA – Bottom Hole Assembly

ECD – Equivalent Circulating Density

HEC – Hydroxyethyl Cellulose

MWD – Measurement While Drilling

BHP – Bottom Hole Pressure

PSA – Petroleum Safety Authority

KOP – Kick-Off Point

TVD – True Vertical Depth

DLS – Dogleg Severity

PL – Production License

MMBO – Millions of Barrels of Oil

RKB – Rotary Kelly Bushing

OWC – Oil-Water Contact

EOB – End of Build

MD – Measured Depth

ROP – Rate of Penetration

WOB – Weight on Bit

RSS – Rotary Steerable System

LWD – Logging While Drilling

## *Acknowledgements*

This Thesis serves as an ending point of my Master's Degree studies. Although formally I am pursuing my diploma at AGH University of Science and Technology in Krakow, Poland, I had a great opportunity to spend my final year of studies at University of Stavanger in Norway. This was possible thanks to generous support of PGNiG Upstream International AS and effective cooperation between both Universities, which I am thankful for.

Personally, I would like to thank Prof. Jann Rune Ursin for his guidance and supervision. I would also like to thank sincerely Steinar Bryne of PGNiG Upstream International AS and Thomas Selbekk along with Morten H. Emilsen of Add Energy for their help, assistance and feedback whenever needed. Your help is greatly appreciated. I would also like to direct great thanks to Prof. Rafał Wiśniowski, Jan Ziaja, PhD., and Krzysztof Skrzypaszek, PhD., for their help and guidance back in Poland at AGH University.



## *1 Chapter I – Introduction – Overview of the Topic*

Petroleum industry has evolved throughout the years and much has changed since its very modest or even primitive beginnings. As new technologies and solutions were being invented and implemented, it is safe to say that health and safety, not only personal but also environmental, might have become industry's biggest concern. As many of the most severe catastrophes in this industry were caused by lost well control incidents, strong emphasis has been put on blowout contingency and well control procedures to prevent blowouts and hydrocarbon spillages, which are the most severe incidents when it comes to both casualties and environmental impact. There are numerous procedures to counteract such emergency situation, but drilling of a relief well and killing a well through it is the last resort option in case of a lost well control. As the relief well control method has been used successfully throughout the years in many different ways, and the concept has been constantly developed, discoveries of shallow reservoirs set new challenges that have to be addressed to access those resources. Designing and drilling of a relief well for such shallow reservoir forces a novel relief well trajectory approach, which later results in numerous challenges that have to be somehow overcome. This Thesis explains the basis for relief well technology, describes the technology itself, points out various design drivers, proposes and discusses a relief well conceptual design for real-life shallow reservoir scenario and challenges associated with such design.

### *1.1 Structure of the Thesis*

This Thesis is divided into 11 chapters. The first chapter serves as the general introduction to Thesis problematics and later describes its structure. Second chapter provides a theoretical introduction to relief well technology. It describes general reason and purpose of such technology, as well as its origins, evolution throughout the years and different industrial approaches while utilizing this technology. It also points out different criteria that have to be taken into account during the design process. Chapters 3 and 4 describe the specificity of shallow reservoir situation when it comes to relief well drilling and provide a very brief explanation of the concept. Chapter 5 describes the Barents Sea Wisting Prospect shallow reservoir scenario thoroughly. In the second part of chapter 5 a detailed description of wildcat well 7324/8-1 is given, for which the relief well shall be designed. Main concern of chapter 6 is the design of the well itself. Firstly, a suitable location is being chosen, then the proposed well trajectory calculated and casing design presented. Various criteria are taken into account on each design stage. Chapter 7 defines and discusses possible challenges associated with such relief well design as the one proposed in this Thesis. Chapters 8 and 9 provide the overall summary of the concept. They conclude the Thesis and propose several directions for future development of this concept. Chapters 10 and 11, which are the last chapters of this Thesis, consist of references list and appendixes.

## **2 Chapter II – Theory**

### **2.1 Blowout**

From the very beginning of petroleum industry's development and commercial crude oil and gas production, it was clear that blowouts stand as possibly the biggest threat to operations safety and profitability. Blowout can result in a huge environmental and financial damage as in case of the Macondo well blowout that occurred in April 2010 in the Gulf of Mexico. The influx of reservoir fluid to the well was not discovered and recognized in time, which led to fatal consequences. Numerous mistakes and negligences resulted in hydrocarbons venting onto the Deepwater Horizon platform, which later resulted in ignition and fire leaving 11 casualties, numerous injured and biggest oil spill in the history, which lasted for 87 days. Deepwater Horizon platform operating on that well has sunk which hampered the blowout control operation. The control over the entire incident was regained in September 2010, as reported by BP after the Macondo well has been successfully shut-in. [1]

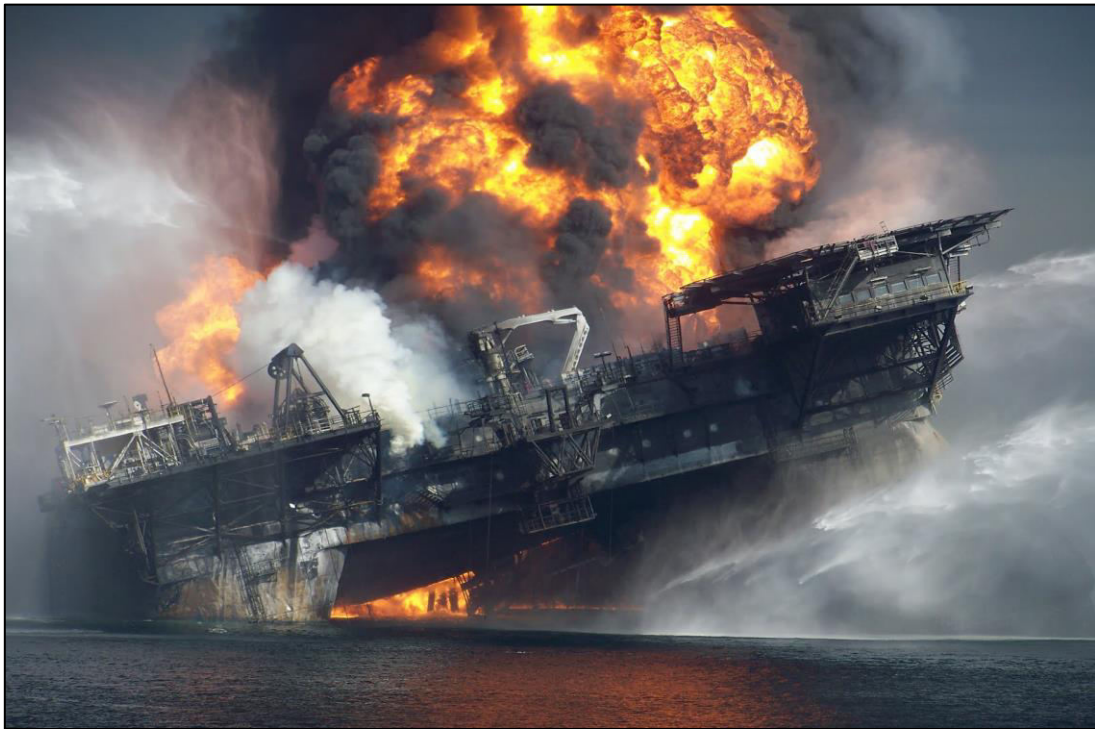

Figure 1 - Deepwater Horizon Platform sinking. [2]

A blowout is then an uncontrolled release of oil, gas, water or mixture of those from the well after the hydraulic stability has been lost or, in other words, the pressure control systems have failed. Practically, blowout can occur on every single stage of well development, starting from drilling phase through well testing and completion, to production and eventual workover. [4] Figure 2 below, presents a blowing subsea well where the blowout has reached the surface and the fluid is blowing onto the platform.



Figure 2 - Surface blowout on a drilling rig. [3]

However, before a fully developed blowout occurs, well gets a so-called kick, which is an influx of reservoir fluid or gas from the formation to the well. If kick is not discovered early enough and suitable operational procedures are not undertaken, then it may turn into a fully developed blowout.

### 2.1.1 Causes of a kick

There are numerous reasons and causes for a kick to occur. According to [5] some of the most important are:

- Uncertainty in pore pressure – nearly all data collected during various measurements and surveys in petroleum industry suffers from some uncertainty. It can be uncertainty regarding well position, expressed in ellipses of uncertainty, or the fact that the well target is an area, rather than a point. Pressure measurements also suffer from uncertainties. It may happen, that during drilling the formation of higher pore pressure is drilled through and suddenly the hydraulic stability of the well can be lost, which results in an influx from the formation to the well. The general rule is that hydraulic pressure exerted by mud column should be higher than pore pressure of the formation (to prevent influx), but lower than fracture pressure (to avoid fracturing).

- Too low mud weight – kick can be taken when the hydrostatic pressure of a mud column is lower than the pore pressure of the formation. If the density of the mud is too low and therefore, the hydrostatic pressure of a mud column is too low, such situation may occur. Mud weight needs to be chosen carefully to control the well pressure but not to fracture the formation. Correct mud weight can be chosen by careful evaluation of pore pressure curve and fracture pressure curve along the well.
- Swab effect – during well operations the drillstring sometimes needs to be pulled out of the hole, for example due to bit wear or to change the Bottom Hole Assembly (BHA). Such doing leads to decrease in hydrostatic pressure of mud column. The drop in pressure depends on the speed of pulling, density of mud and well geometry. If it is significant enough to lower the hydrostatic pressure below the pore pressure the kick from the formation can be taken.
- Insufficient refill of the well with mud while tripping out – while tripping out, which means pulling the drillstring out of the hole, the decrease in the mud level in well occurs. Mud level drops for the same volume, as the volume of the string pulled out. This is why during tripping out there is a need to fill the hole with mud to sustain the hydraulic stability of the well or else, the hydrostatic pressure of the mud left in the well may not be high enough to balance the pore pressure. Such situation may lead to a kick.
- Lost mud circulation – this is a pretty severe reason, not only due to the fact that the kick may be taken, but also because mud itself is very expensive and significant losses can cause financial damage. When mud circulation is lost and fluid escapes into the formation, the level of mud in the well drops, which can result in a kick due to the low hydrostatic pressure of a mud column. Circulation can be lost from natural causes such as a strongly fractured formation. Mud then flows into the pores and fractures in formation. Formation can be also fractured due to the too high Equivalent Circulating Density (ECD) of mud. In such case, reduction of mud weight and pump rate is strongly advised. Mud circulation can be also lost due to the effect of pressure surges, which is a contrary effect to swabbing. Pressure surge is a temporary increase in well pressure associated with tripping in (for example of a drillstring). To prevent surging one must avoid tripping in too fast.

As mentioned earlier, if a kick occurs and is not detected and handled in time, it may lead to the blowing well situation.

### *2.1.2 Types of blowout*

According to [4] blowouts can be qualified into 3 basic categories:

- Surface blowouts – occur when hydrocarbons, water, mud or their mixture reaches the surface (rig floor). Fluid travels up in the well, breaches through well control barriers and their elements, such as Downhole Safety Valves or Blowout Preventer. Such blowout itself is a great threat due to the enormous force of blowing fluid, which can cause damage to personnel and to the rig itself. Additionally, due to the presence of hydrocarbons which are easily flammable, a spark or high amount of heat can result in hydrocarbons ignition and fire, which can be very challenging to control and requires specialized well control actions.
- Subsea blowouts – this type of blowout occurs when fluid travels up in the well from the formation to the subsea wellhead located on the seabed. Fluid does not reach the rig floor as it was the case in surface blowout, but vents into the sea, usually at subsea wellhead. Subsea blowout situation is therefore complicated due to the fact that to control it, underwater operations must be performed, often in harsh environment. The fact that blowout fluid vents directly into the sea is also of great importance and danger, as it can cause huge environmental damage.
- Underground blowouts – that is a peculiar type of blowout, where the blowing fluid does not travel up in the well to the wellhead, but between particular zones in the formation. Fluids from high-pressure zones within the reservoir travel to the zones of lower pore pressure. Such blowouts can lead to several problems during further exploration and production.

### *2.1.3 Blowout kill & control*

As there are numerous ways to prevent blowouts, and if the prevention was not successful and the influx of the fluid to the well results in a blowout situation, there are various ways to control it. Usually, in a blowing well situation firstly surface solutions will be considered. However, sometimes, the control of the blowing well cannot be regained only by surface actions and procedures. If the force of the blowing fluid and its impact is particularly big and does not diminish overtime, it may occur that the well cannot be capped. Then, there may be a requirement to undertake underground actions to control such situation. Such blowout control strategy can be implemented by the drilling of relief wells and regaining the control over well through them. It is also possible to perform both surface and relief well actions simultaneously. [6] Some of blowout kill methods are:

- Capping – it is a surface blowout contingency method. This method refers to mechanical well shut-in. The well is being closed at its exit and the flow of the blowing fluid stops, as it

encounters a mechanical barrier. Various elements can serve as well closing points, including special capping stacks, shear rams, ball valves or diverter. After the well has been closed, the pressure in the well will gradually increase, so careful pressure monitoring procedures are vital in an attempt of capping a blowing well. Depending on the situation, there are various ways to cap a blowing well such as: to restore existing BOP, stabbing, drillstring capping, annulus capping or side-entry capping. Usually methods such as bullheading are used to kill the well after it has been capped. [4]

- Bullheading – this method implies that fluids (for example mud) are being forced and pumped from the surface into the well. This technique is often used when there is a danger that the blowing fluid will contain harmful or dangerous substances such as H<sub>2</sub>S (Hydrogen Sulfide). This operation can be risky as it is performed with high pressures and the crew cannot control to which part of the formation the pumped fluid will flow. Fluids will be forced into formations that are highly depleted, fractured and have the lowest pore pressure and fracture pressure. There is also a real danger of fracturing the formation at the last casing shoe. Bullheading requires the facility to have enough pumping power. [18]
- Bridging – this is a term used when the well blowout stops itself. It usually happens at the very beginning of blowout incident and refers to cases such as depletion or choking with sand or formation. The formation can simply ‘run out of blowing power’, especially in the case of shallow gas pockets. The pressure of the blowing fluid can be high enough to fracture the formation along the well and create alternative way, instead of forcing it up the well. The well can be also choked with sand or formation debris carried along with the fluid flowing from the formation, this happens especially in weak and fractured formations. [4]
- Dynamic kill – kill fluid is pumped through the relief well into the blowing well. It creates frictional pressure loss and lowers the pressure of a blowing fluid. Flow is stopped dynamically. The hydrostatic pressure of the kill fluid is eventually higher than the pressure of blowing fluid flowing from the formation and the well is killed. This method is described thoroughly in following paragraphs.
- Formation pressure relieve with relief well – historical approach where the pressure of blowing formation was lowered by producing through the relief well at high rate.
- Permanent cementing – after the control of the well has been regained and the hydraulic stability established, permanent cement barriers can be placed across the well to prevent further flow from the formation.

## 2.2 Relief well

### 2.2.1 Relief well origins

Firstly, the idea behind a relief well was to drill a vertical well that will reach the high-pressure blowing formation and allow for a high-rate production to relieve the pressure of that formation, which could not be achieved by original well. This way the pressure of the blowing well would drop and the blowout would be eventually controlled. [6]

However, in the year 1933 on the cratered, blowing well in Conroe, Texas one of the biggest steps in the relief well technology development has been made. Thanks to, for that time, quite advanced borehole surveying instruments, it was possible to drill a directionally controlled relief well which reached the blowing formation and intersected it. Later on, water was pumped through the relief well into the formation, which eventually led to successful blowing well kill. [6]

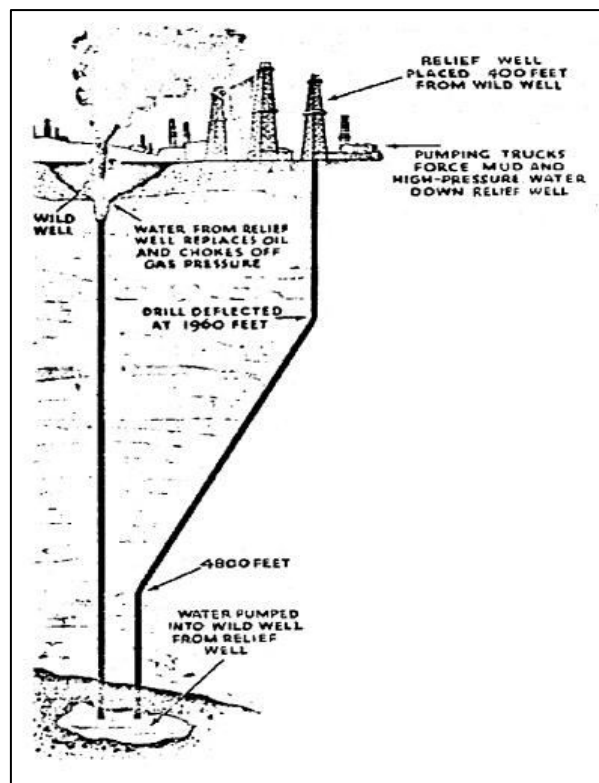

Figure 3 - Relief Well in Conroe, Texas, 1933. [7]

Similar concept of a relief well was being utilized throughout the years from 1933 to 1970. Relief well was drilled, it intersected the blowing formation and then either water, or in case of higher reservoir pressures, kill fluid of higher density was pumped into the formation which eventually allowed for a blowing well kill. Sometimes, the reservoir was flooded with the injected water. The communication between blowing well and relief well was achieved through the water flow channels. Additionally, such techniques as acidizing or fracturing were used to ensure the success of the operation and well kill. Due to large well position uncertainties associated with simple well surveying equipment often

more than one relief well was drilled. However, due to the advancement of drilling techniques there was also a need for the relief well strategy to allow for control of blowing wells that could not be controlled using the original concept. To achieve that technology development was needed. [6]

In the year 1970 Shell's exploratory well in Piney Woods, Mississippi blew out. It created a challenge as the blowing well itself was more than 6700 m deep. Due to the large uncertainties in borehole positioning and significant risk of failure, drilling of a relief well to such depth was unacceptable. However, wireline surveying tools were used to detect the presence of blowing well tubular and casing. When it was certain that the blowing well was close to the relief well the communication between wells was possible due to perforation from relief well to blowing well at the depth of 3200 m. It was the first time in the history, when direct communication and intersection between relief well and blowing well was achieved. This case stands as a base for modern relief well technology and strategy. [6]

### *2.2.2 Technology development*

Throughout the years, technology associated with relief wells has moved forward, as it was vital to follow the progress in drilling technologies and secure the possibility of controlling blowing wells in complicated environmental, geological or operational conditions. Numerous solutions have been invented and implemented to assure better borehole surveying, blowing well detection, accurate intersection and successful well kill. This section is based on [6]. Some of the solutions are:

- Magnetostatic detection tools – this technology allows to orient the relief well and control its position in reference to the blowout. Firstly used in 1975 on a blowing well incident in Gulf of Mexico. These tools measure the interference of natural magnetic field caused by blowing well casing string or drillstring. The radius of detection varies from 6 up to 12 m and depends on the strength of magnetic field in a particular location. For premagnetized casing joints the detection area may be larger. [6]
- Special kill fluids – as wells were being drilled in more complex and challenging formations, sometimes blowouts could not be handled with the use of regular kill fluids or water. This was the case in year 1976, when in Persian Gulf the well had been drilled and at the depth of 1070 m the blowout from gas formation of high permeability occurred. Decision was made to regain the control of the well by drilling four relief wells that will intersect with the blowing well. However, it was impossible to control the blowout with conventional kill fluids. It was the first time where special kill fluids, in that case with added Guar Gum and Hydroxyethyl Cellulose (HEC), were used. High-viscosity Guar Gum kill fluid pumped above the reservoir resulted in reduced gas flow from the formation while the addition of HEC prevented from



unwanted kill fluid losses into depleted, highly-permeable formation. From that moment on, numerous special kill fluids are being used and various additives happened to be useful in the blowing well kill situations. [6]

- Dynamic kill technique – refers to the strategy, when blowout is controlled by the kill fluid of adequate density that is injected at a certain flowrate into the well. This technique allows for a well kill without entirely closing the well with surface equipment. [8] First documented use of that technology took place in 1978 on a gas blowout situation in Indonesia. Firstly, water was injected into the relief well at a high flowrate to kill the blowout and then, in order to contain the reservoir pressure, kill mud of higher density was pumped into the well. One of the biggest benefits of this technique is the fact that it allows for a well pressure to be systematically controlled in order not to fracture the formation. Main drawback is high pumping power demand in order to kill the well with low density fluid such as water. [6] This technique is thoroughly described in following chapters.
- Electromagnetic casing detection – this technology was developed in the early 1980's and its goal was to orient the position of blowing well tubulars in reference to relief well position. During the blowout in 1980 in Gulf of Mexico the electrical current was forced through the blowing well tubular. The wireline tool was used in a relief well to transmit the current and measure the strength of a magnetic field caused by the electric current and therefore, orient well positions and distance between them. Back in 1982 similar technique has been used to prove that the blowing well casing string can be detected from the distance of up to 60 m. Thanks to that development the accuracy of relief well operations increased drastically. It was far easier to locate the wells in reference to each other and achieve direct intersection of a relief well with blowing well. [6]
- Borehole surveying – 1980's is a period of a rapid improvements on that field. A big step forward was made, especially when it comes to Measurement While Drilling (MWD) tools. Those were more accessible, commercially profitable, smaller, more accurate and could transfer information between the well and topside instruments faster. All of this resulted in a better accuracy of relief wells, lower demand in the number of relief wells needed to successfully handle the blowout and higher success rate of such operations. Also, a significant progress was made in understanding of magnetic interference and its effect on surveying instruments. [6]
- Surface kill equipment – a big step forward was made as the blowing well control operations required more power, more accuracy and easy control. With the increasing pressures in wells, there was a need to develop portable modules of pumps connected together, capable of

pumping large volumes of various kill fluids under high discharge pressures. Those modules could be easily mounted on both onshore and offshore facilities and provided advanced well kill capabilities in a manner that was easy to coordinate and control. The nature of blowing well kill operations changed drastically. High pressure pumping modules were able to create discharge pressure of up to 20 000 psi (1380 bar). Also, big improvements have been made in the offshore sector, especially in automatic/remote operations. [6]

- Steerable systems – those technologies allowed for a better accuracy and placement of relief wells. The first use of steerable systems in a relief well drilling operation was in 1988. The drillstring with stabilized bent motor and sophisticated MWD system was able to drill a relief well of a complicated trajectory. From that moment on, steerable systems are often used as they guarantee fast and accurate relief well development. [6]

### 2.2.3 *Relief well strategy today*

As pointed out earlier, if a blowout occurs, and after careful evaluation the decision is made that it cannot be controlled with surface methods such as capping or bullheading, the relief well strategy needs to be implemented. There is not much difference in the process of drilling a well itself, but rather in purpose.

Nowadays, it is vital for a relief well to directly intersect with the blowing well, penetrate its casing and create direct hydraulic connection between the wells. This provides the operator with ability to pump mentioned earlier various kill fluids (salt water, heavy mud, special kill fluids) depending on situation requirements. Figure 4 shows the general scheme of a relief well strategy. What is also worth mentioning, is that even today, with all the advanced technology available in the industry, drilling of a relief well is a very precise and demanding operation. Often, on the well planning stage, two or even more relief wells need to be designed in case of a blowout situation. Relief wells are often drilled simultaneously, in case of a failure of one of them the second can still guarantee successful blowout control.

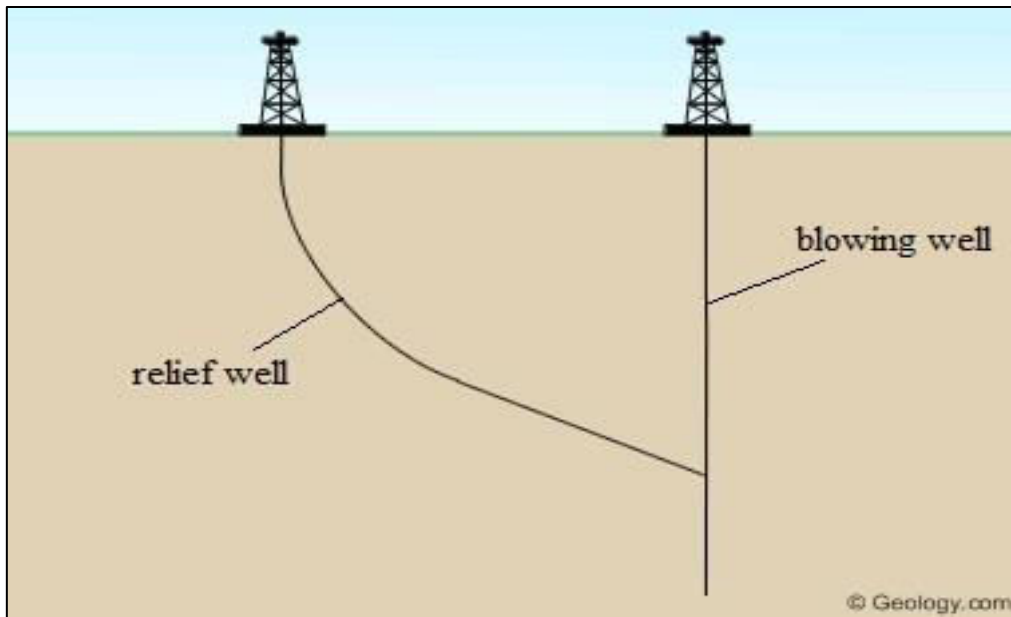

Figure 4 - Relief well scheme. [9]

The crucial part of drilling of a relief well is the stage when the well approaches the blowing well itself. Back in the old days, the uncertainties of well's position towards each other and of direct intersection were huge. Nowadays however, as mentioned in the paragraph describing the development of relief well drilling technology, we have at our disposal a wide variety of technologies that allow for a better borehole surveying and directional control. Magnetic and electromagnetic casing detection tools allow for a precise spatial orientation of the wells, as showed in Figure 5. Steerable systems provide the ability to control the trajectory of relief well and good accuracy.

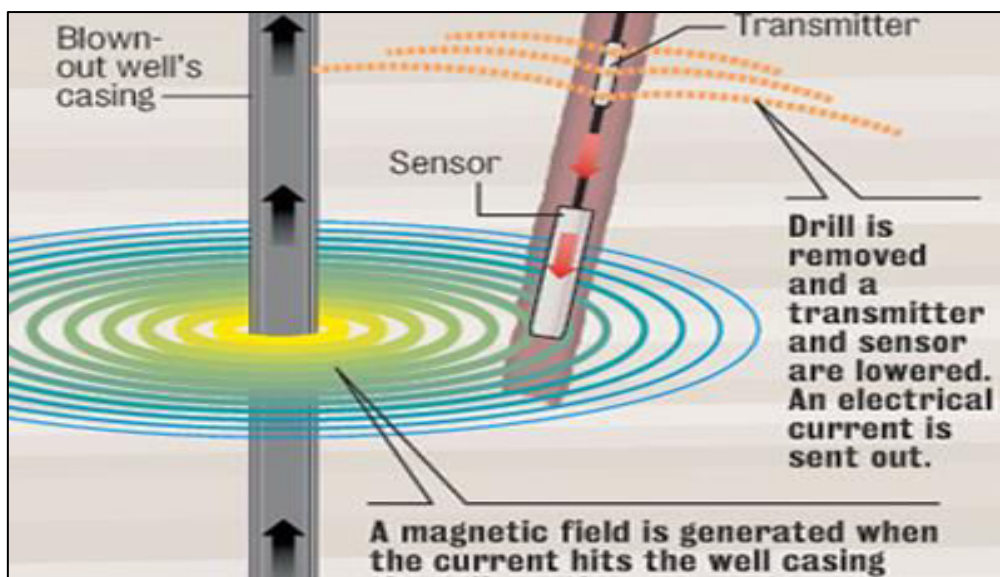

Figure 5 – Electromagnetic casing detection scheme. [10]

As it can be seen in Figure 5, on the example of Electromagnetic casing detection tool, when the relief well approaches the blowing well casing, a large electrical current is forced through the casing of the blowing well, which generates the magnetic field around it. A magnetic sensor is ran into the relief well, below the current transmitter, to measure the strength of the artificial magnetic field and orient the position of the relief well in reference to blowing well. Knowing the positions of both wells, accurate operational decision can be made to assure successful intersection and good hydraulic communication between wells. Finally, to assure the success of a relief well drilling operation, wells should intersect with each other in a particular manner as showed in Figure 6.

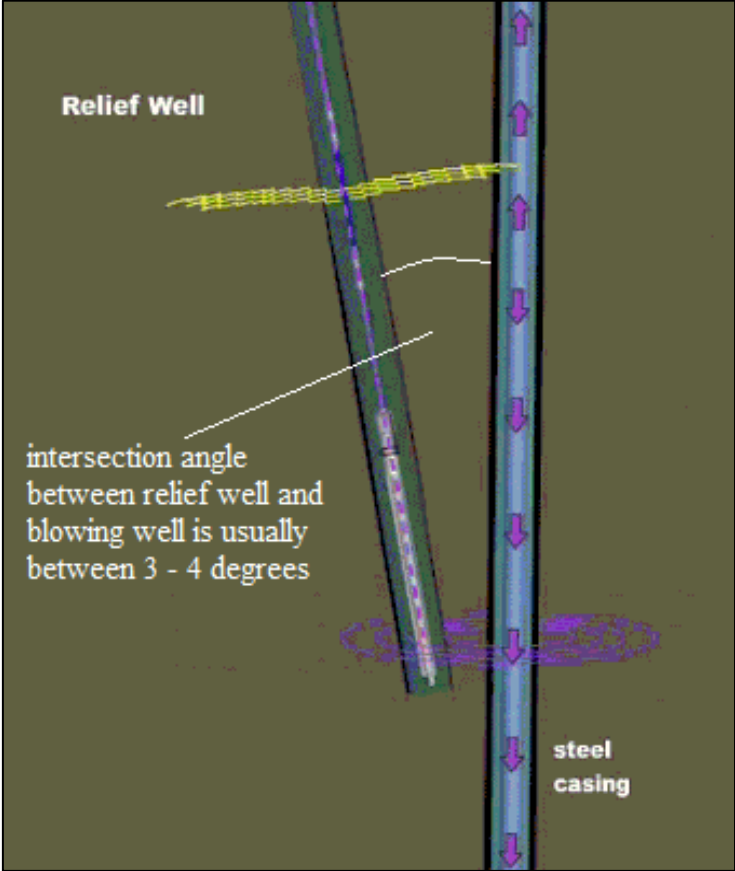

Figure 6 - Relief well and blowing well intersection scheme. [11]

Driller’s goal is to drill a relief well in such manner that when it will be approaching the blowing well the angle between the wells should not exceed 3 - 4 degrees as presented in Figure 6. As it would be very difficult to directly drill through the blowing well in first attempt, the goal is to rather align the trajectories of both wells. It is much easier to intersect the wells when they are nearly parallel to each other and in the first approach the blowing well is detected and intersection can be achieved in the second approach. This intersection technique and strategy results in a usually S-shaped relief well trajectory as presented in Figure 7. However, relief well trajectories will be discussed thoroughly in the following chapters of this thesis.

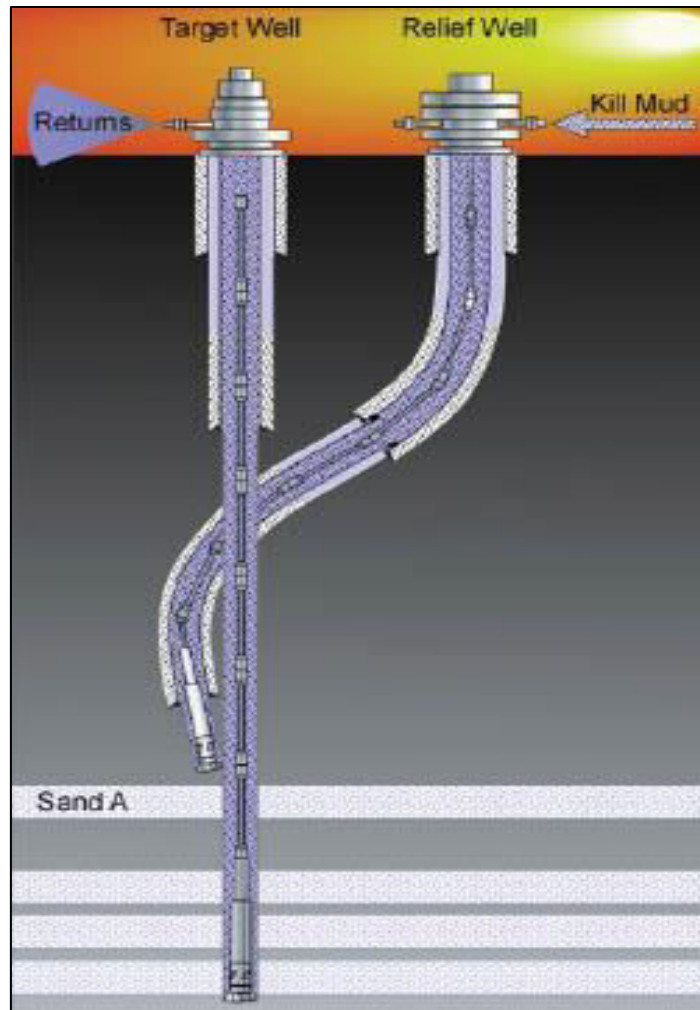

Figure 7 - Typical relief well trajectory and pumping scheme. [12]

When the relief well successfully intersects with blowing well, the dynamic kill procedure can be started. The idea is that the sufficient volume of kill fluid of adequate density is pumped through the relief well at adequate flowrate such that the Bottom Hole Pressure of relief well is higher than the pressure of blowing formation. This stops the flow from the formation and allows for a blowout control. This way, control over the blowing well can be regained. However, well must be killed both dynamically and later statically.

2.2.4 Typical relief well trajectories, intersection methods, intersection point [13]

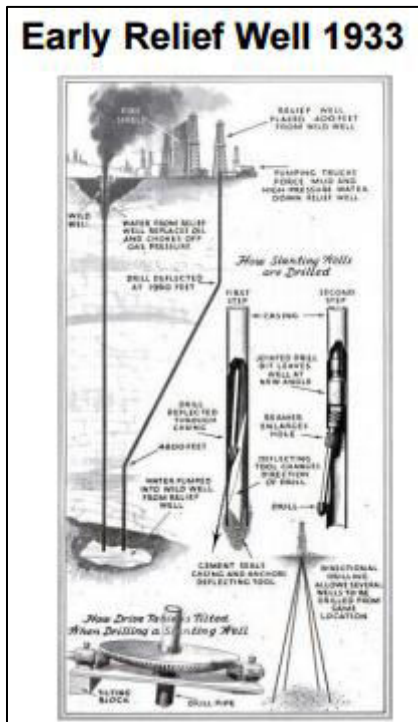

Figure 8 - Early relief well scheme. [13]

At the very beginning of relief well strategy and technology development, there was no incentive for a direct intersection of a relief well with the blowing well. The approach was to relieve the pressure of a blowing formation with the relief well. Due to lack of accurate borehole surveying tools such intersection would be hard to achieve. Relief well used to intersect the blowing reservoir. An example of such solution is a previously discussed blowout in Conroe, Texas in 1933.

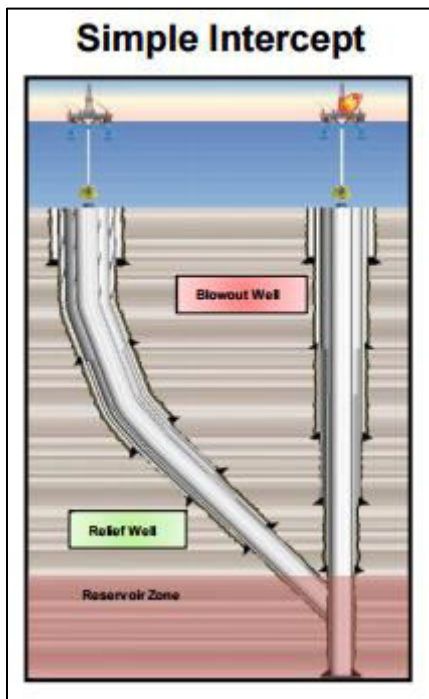

Figure 9 - Simple interception scheme. [13]

After many years, as the drilling technology evolved and more complex reservoirs became accessible, the necessity for direct intersection of the relief well with blowing well occurred. Relief wells sometime had J-shaped trajectory, which later evolved in a S-shaped. The idea was that wells should intersect at adequate depth and the angle between well's central axes should be very small. Intersection usually takes place above or just after entering the reservoir zone, depending on where the blowout was taking place.

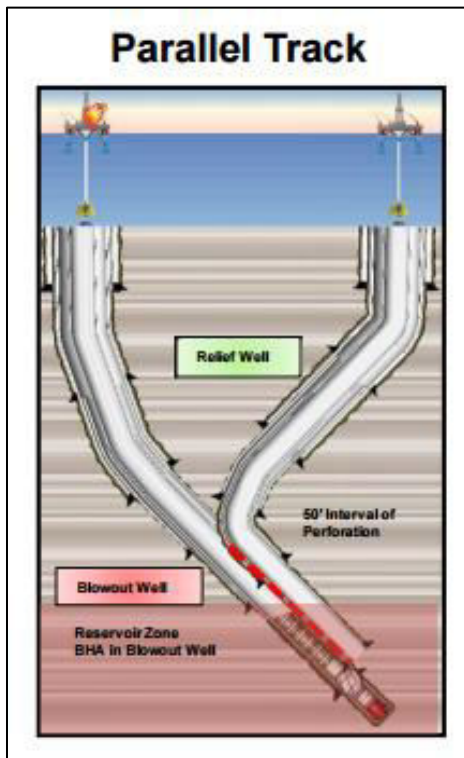

Figure 10 - Parallel track intersection scheme. [13]

This concept can be utilized when the blowing well is a directional well of a certain inclination. The strategy is to approach the blowing well with the relief well in a parallel manner with a very small distance between them. Later on, the perforating gun is run into the relief well and on a certain length perforations between relief well and blowing well are being made. Communication can be achieved slightly above reservoir zone and directly in reservoir zone of the blowing well.

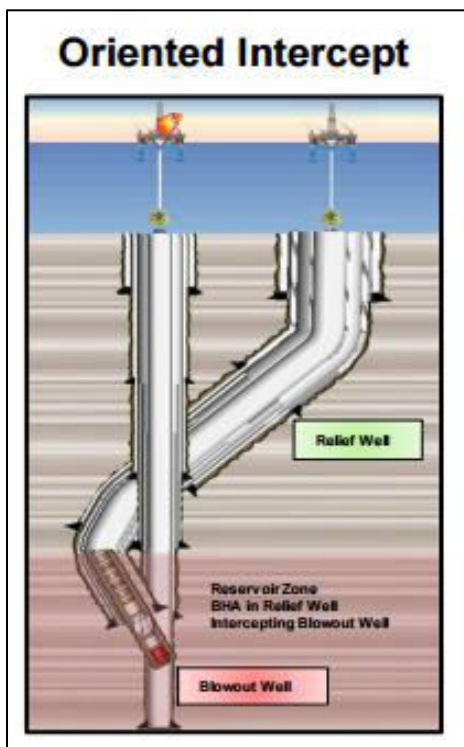

Figure 11 - Oriented interception scheme. [13]

Oriented interception of relief well and blowing well is the most commonly used approach nowadays. Relief well is usually S-shaped to firstly orient and localize blowing well and to intersect it with a relief well at second approach. The angle between well's axes is very small (less than  $5^\circ$ , usually  $3^\circ - 4^\circ$ ). S-shaped relief well gives also a certain advantage when it comes to pressure control procedures and pumping. Oriented interception strategy thoroughly utilizes advanced borehole surveying and directional control tools.

As a typical S-shaped relief well is being drilled, it consists of a straight, vertical section that approaches the first KOP at shallow depth. From that point well trajectory starts to build inclination. When the required inclination is obtained, a long, straight, inclined section is being drilled in the direction of the blowing well. Sail angle in that section rarely exceeds  $50^\circ$  as presented in Figure 12. The well is continuously being drilled in the direction of blowing well up until the moment it approaches blowing well casing. The first point of approach between relief well trajectory and blowing well is used to detect the blowing well with surveying and localizing tools used in relief well. At that point, the distance between both wells must be bigger than 30 ft (slightly more than 9 meters). The angle value between well's axes usually oscillates around  $10^\circ$ . When the blowing well casing is successfully detected and localized, the relief well trajectory will change direction and the process of tracking and orienting for interception begins. [13]

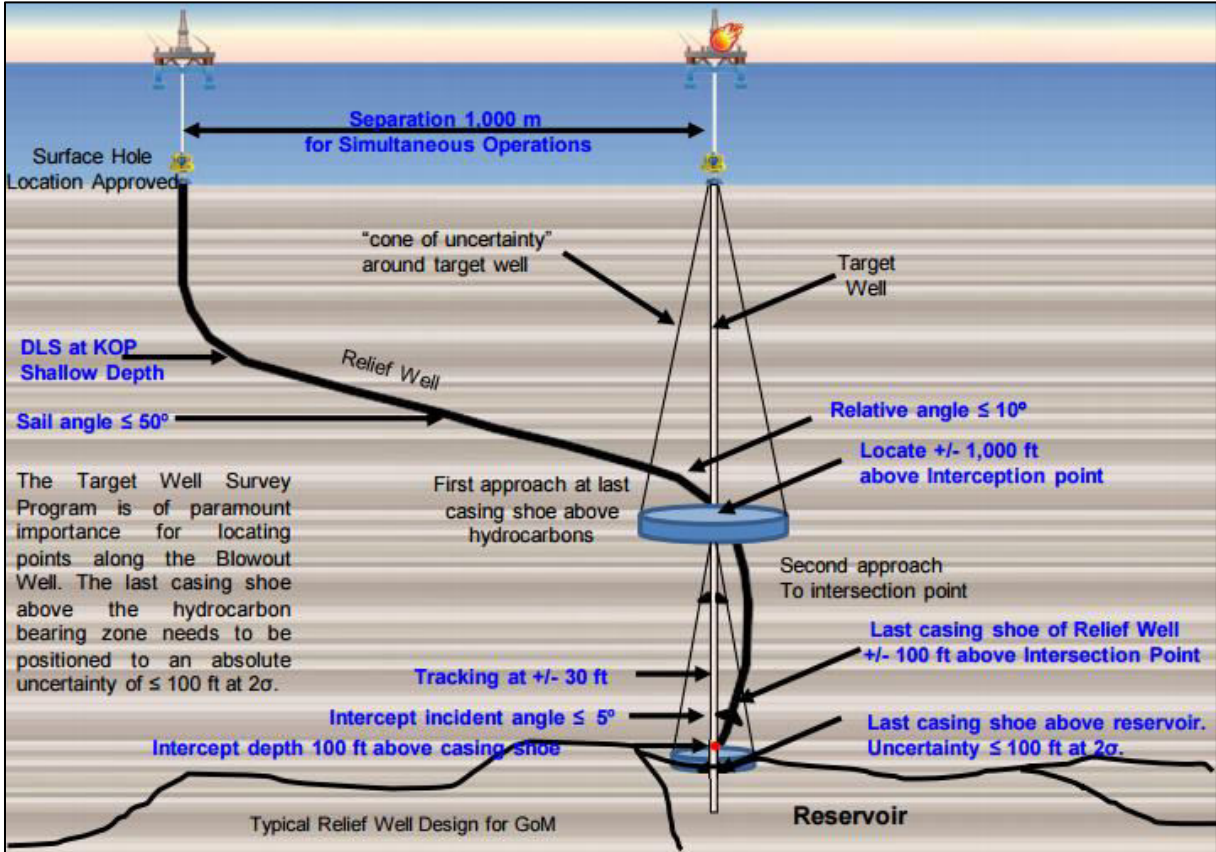

Figure 12 - Relief well trajectory and interception approach. [13]

From now on, the inclination of relief well will gradually drop, as the well will be approaching the blowing well itself, tracking it and orienting for interception. The interception usually takes place 100 ft (roughly 30 meters) from the last casing shoe of the blowing well. The last casing shoe of relief well is usually located around 100 ft (30 meters) from the intersection point as well. When the relief well is oriented for interception, it approaches the blowing well and intersects it at small angle ( $\leq 5^\circ$ ). This phase is presented in Figure 13. [13]



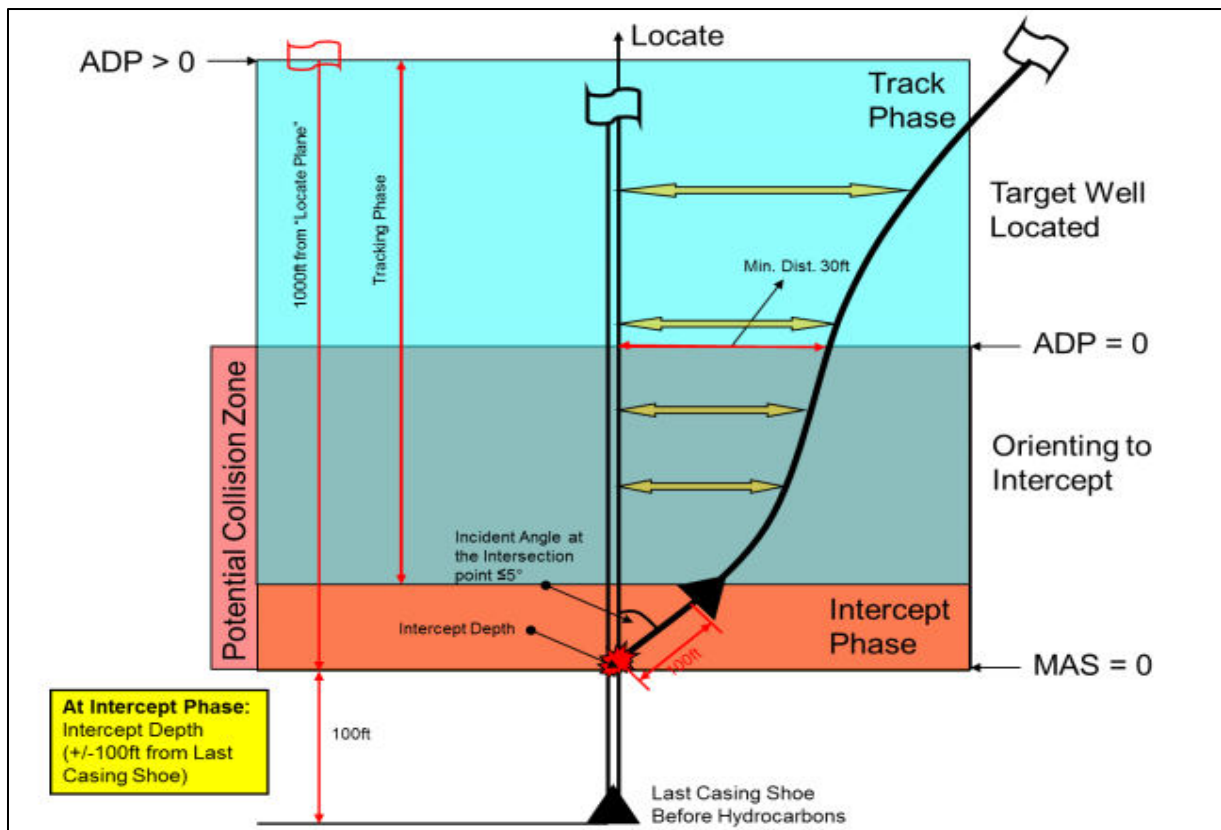

Figure 13 - Locating, tracking, orienting and interception phase. [13]

### 2.2.5 Subsea relief well surface location and rig placement drivers

Identifying a potential surface location for a relief well is a crucial part of the well design process. This process requires careful study and evaluation of all potential data regarding infrastructure, operations, seafloor topography, geophysical analysis and meteorological data. This way, the optimal locations for relief well placement can be chosen and no-go zones can be successfully avoided. [14] Relief well placement will depend on:

- Infrastructure/operations placement – relief wells cannot be located in a direct proximity of offset wells, pipelines, shipping routes, other rigs. Such doing could be harmful to relief well drilling operation and cause damage to mentioned infrastructure or disrupt operations. [14]
- Seafloor topography – the idea is that the relief well should be drilled from stable and flat location on the seafloor. Unstable zones should be avoided. No-go zones are also various slopes and knolls of different elevations. [14]
- Distance from the blowing well – relief well cannot be placed closer to the blowing well than 500 meters, but on the other hand, distance between them cannot exceed 3000 meters. Usually this distance varies from 1000 to 1500 meters. [14] [15]

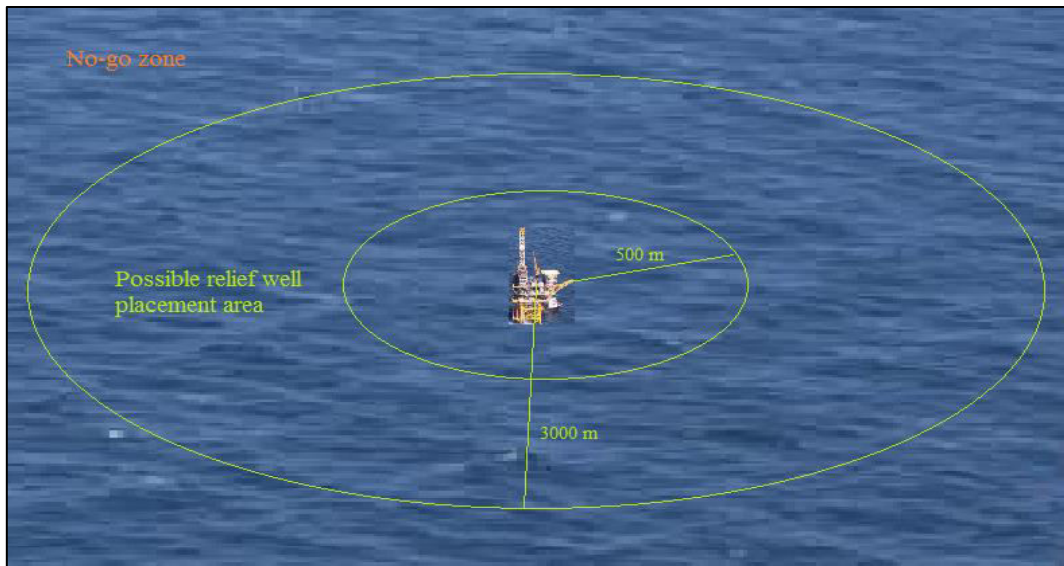

Figure 14 – Distance from the blowing well scheme.

- Water depth – the general rule is that in case of a very shallow water (< 300 m), relief well must be placed further from the blowing well than it would be in case of deeper water. [15]
- Shallow dangers – potential relief well location should be thoroughly reviewed for the presence of possible shallow gas accumulations. Presence of shallow gas will strongly affect the drilling process. Careful evaluation of geophysical surveys is required. [15]
- Marine/meteorological data – relief well location should be up-wind and up-current in reference to the blowing well location. [16] This is an important HSE issue, to prevent smoke, fumes, fire, oil migration towards the relief well along the wind/current in case of blowout. This concept is picture below in Figure 15 and is the same for sea current.

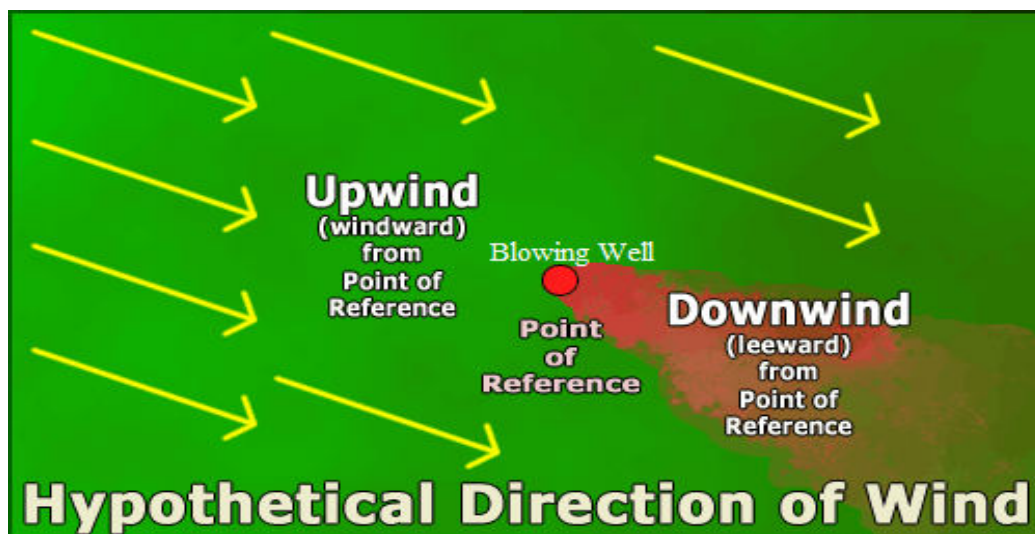

Figure 15 - Upwind location concept. [17]

### ***2.2.6 Relief well design & planning process***

This section is strongly based on references [6], [13], [16] if not stated otherwise.

According to Petroleum Safety Authority of Norway (PSA) every petroleum activity, which involves a procedure of drilling a well shall include a well control plan in case of the lost well control scenario. In the well control plan it should be proved and designed for, that it is possible to control the well with surface actions such as for example capping. Well control scenario should also include a design of at least one relief well that the blowing well could be controlled with. In special cases, if well requires more than one relief well to control it, it shall be designed for as well. [19] NORSOK Standard D-010 points out that the outline plan for drilling relief wells should indicate at least two locations for a relief well, as usually in a blowing well situation at least 2 relief wells are being drilled simultaneously in case one of them fails, to mitigate the probability of failure.

Relief well design and planning process consists of a constant discussion about the best way to kill the well but also about the most safe and efficient way to drill the relief well and intersect with the blowing well. Relief well design must be optimal for both killing the blowing well but also for drilling and intersection operations. If the proposed design cannot be accepted due to violations on one of those fields, a new design should be proposed and evaluated. [6] A typical relief well design and planning process consists of such phases as [13]:

- Data gathering – this process includes gathering of data from all possible sources that may turn out to be useful in the process of designing a well and drilling. Information relevant to relief well placement should be obtained such as subsurface infrastructure scheme, geophysical analysis, seafloor map, meteorological prognosis and others. Data about geological properties of formation, local stratigraphy, formation and reservoir pressure/temperature/water content shall be gathered as well. After all relevant information are available possible locations for relief wells should be chosen and collaborative well design session conducted. Also data relevant to drilling and intersection procedure shall be available.
- Drilling – process of drilling a relief well should be designed. Adequate trajectory for the well should be proposed, discussed and proved feasible, including depths of Kick-Off Points (KOP), lengths of sections, angles, azimuth and inclination, casing and cementing design. Torque and drag calculations shall be performed as well. Kill plan should be designed and evaluated, including suitable rig/vessel types, necessary equipment with appropriate capacities and description of kill method. Those procedures should be planned in advance, including BHAs, drillstring steering methods.

- Location and Tracking – the concern of this part is the placement of relief well and blowing well in reference to each other. Tools for spatial orientation of drillstring should be chosen (MWD, steerable systems) which shall guarantee safe and efficient relief well drilling. As the relief well trajectory approaches blowing well, a system for location of both well shall be designed. Ranging tools and casing detection tools should be chosen (such as electromagnetic tools and sensors). Also MWD tools that inform about the inclination and azimuth of the well are used. The process of orienting for interception shall be designed.
- Interception – the interception point shall be carefully chosen and the procedure designed. Depth of the interception point should make it possible to obtain direct intersection of blowing well with relief well and provide with the ability to kill the well. Much attention shall be given to the angle of interception and to the depth of last casing shoe of relief well. Also it should be carefully evaluated where in the formation the interception will take place.

### 2.3 Dynamic kill

This chapter is based on reference [20].

Dynamic kill is the remedial method which is supposed to kill the blowout and regain the control of the blowing well. After the relief well has been successfully drilled and the hydraulic communication between relief well and blowing well has been established, the dynamic well kill procedure is started.

At first, a low density fluid, such as in case of subsea wells a salt water, is pumped down the drillpipe of the relief well to the blowing well. This allows for pressure monitoring at intersection point. At the very beginning, this low density fluid pumped down the relief well exerts hydrostatic pressure lower than the pressure of the blowing formation. However, fluid is pumped at such rate, that it creates additional frictional pressure which summed up with hydrostatic pressure of the fluid column should exceed the pressure of the blowing formation. In that case the blowing's well Bottom Hole Pressure (BHP) is:

$$p_{BHP} = p_{hydrostatic} + p_{friction} + p_{wellhead} \quad [bar]$$

The BHP at the intersection point increases so the inflow of the fluid from the formation will decrease until the BHP is sufficient to stop the flow of the fluid completely. What is important, is that the BHP should be bigger than the pressure of blowing formation, but lower than the pressure of fracturing.

$$p_{blowing\ formation} < p_{BHP} < p_{fracturing}$$

However, low-density fluid such as salt water is not heavy enough to kill the well for good (statically). Therefore, a high-density kill fluid needs to be pumped down the annulus of the relief well. Heavy kill fluid has density high enough to produce sufficient hydrostatic pressure to block the potential inflow of the fluid from the reservoir and prevent further blowout. The pump rate while pumping of heavy fluid is smaller than the pump rate for salt water to prevent formation fracturing. When the relief well has been filled with heavy kill fluid and all remaining reservoir fluid have been removed the pump rate can be gradually lowered up to the point when the well is statically dead. The dynamic kill procedure scheme has been presented in Figure 16. [20]

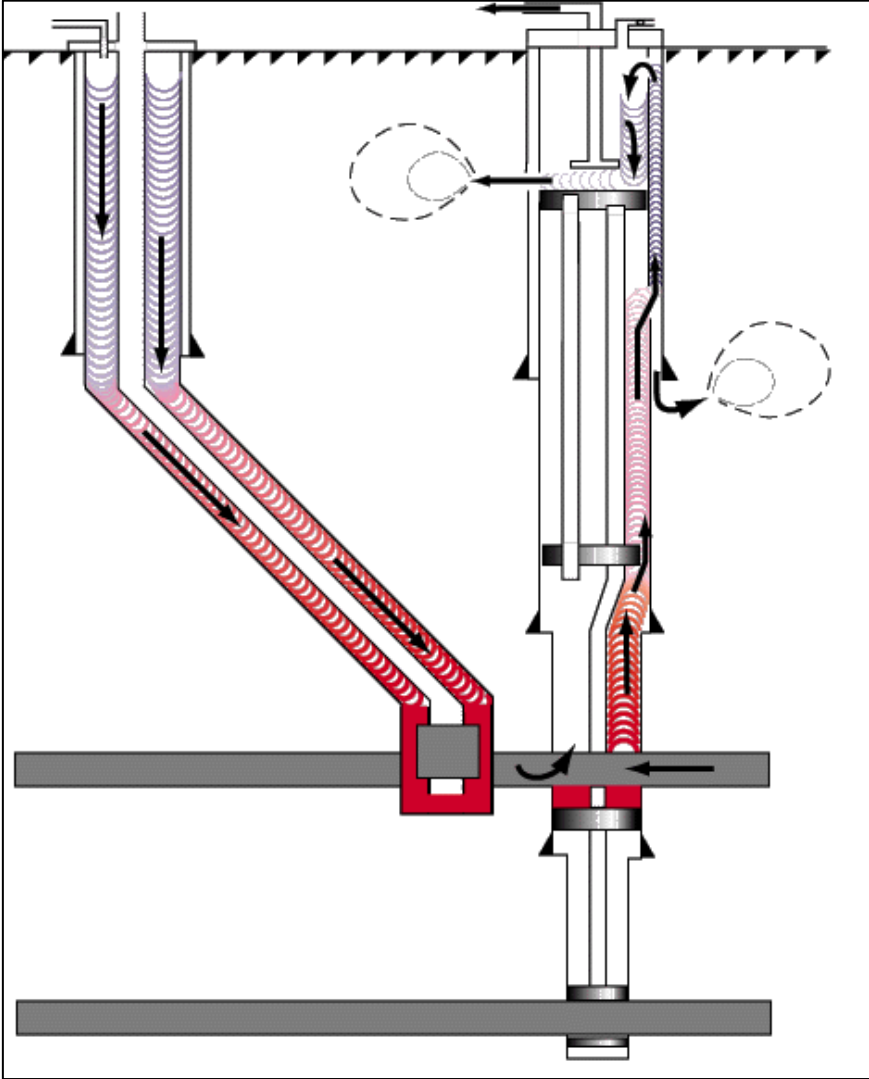

Figure 16 - Dynamic kill procedure scheme. [21]

### 3 Chapter III – Defining Thesis Problematics

An important matter that needs to be noticed is that in the overall relief well concept the reservoir is usually located deep or very deep and is buried under numerous layers of formations, as this is a typical situation for oil and gas exploration and production. In such case, a primary well (either exploration or production) that is drilled to the reservoir has significant True Vertical Depth (TVD). Such situation is presented in Figure 17, which is a scheme of Macondo well (red) and two relief wells (green) drilled to regain control of the well during blowout. As it can be seen in the Figure, water depth in this case is larger than 1500 meters and the depth of the well from the seabed to the reservoir is approximately 4000 meters (more than 5500 meters from Mean Sea Level). Macondo well is a bit of an exaggeration as it is an example of a very deep well drilled in deep water conditions. However, the point is that usually the depth of exploration or production wells is significant as reservoirs are often located deep, which gives a certain design freedom and a wide spectrum of possible approaches for a relief well placement, trajectory and overall design. As it was pointed out in theoretical introduction, relief wells are then usually designed as S-shaped.

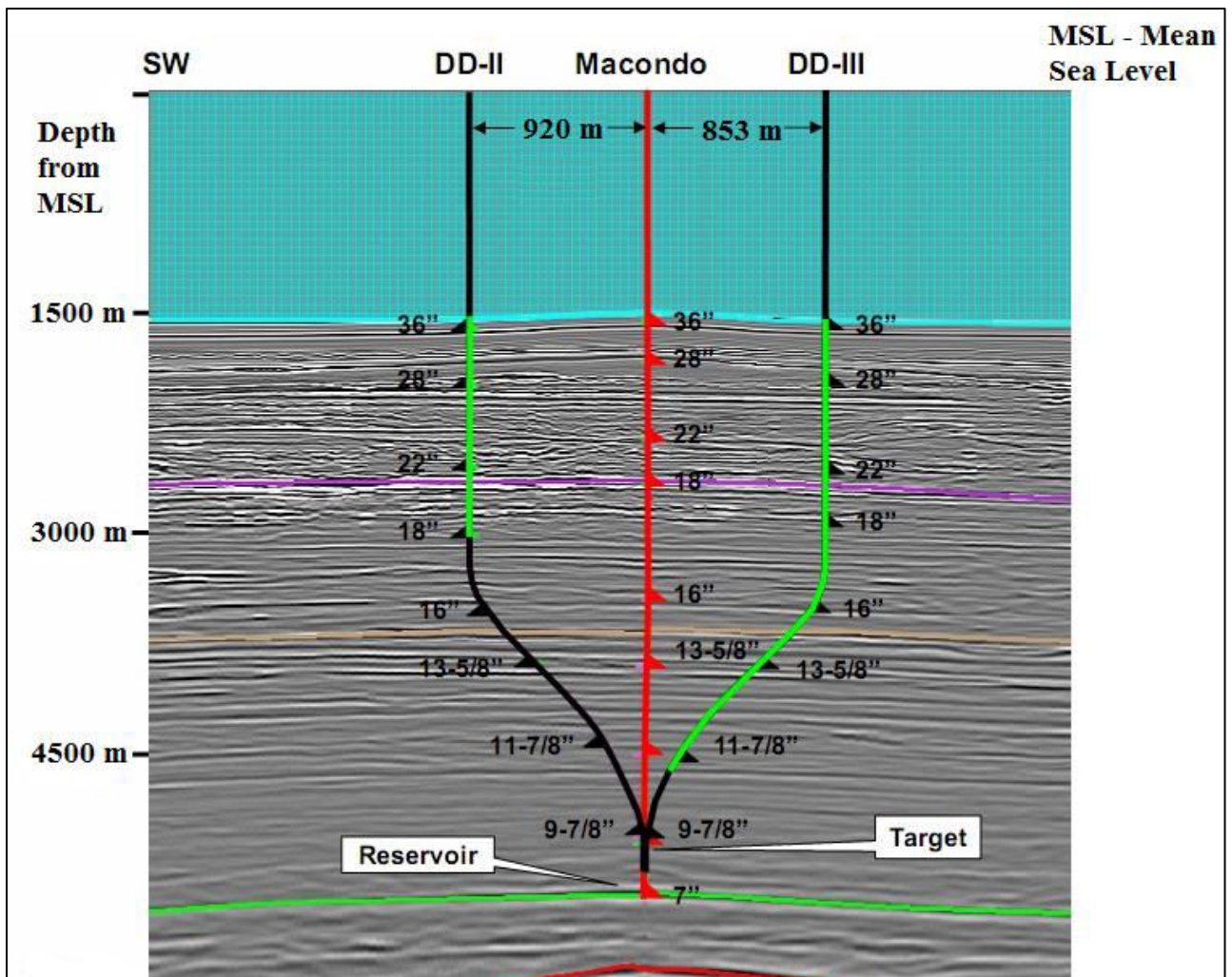

Figure 17 - Relief wells for deep reservoir. [22]

Problem occurs, when the reservoir placement is unconventional and therefore, the exploration or production well that has to be drilled will not be a typical well with significant TVD ( TVD < 1000 m). Such situation will strongly affect the design of eventual relief wells as a typical S-shaped trajectory would not be applicable. Situation presented in Figure 18 could be considered as unconventional due to the very shallow depth of the reservoir below the seabed.

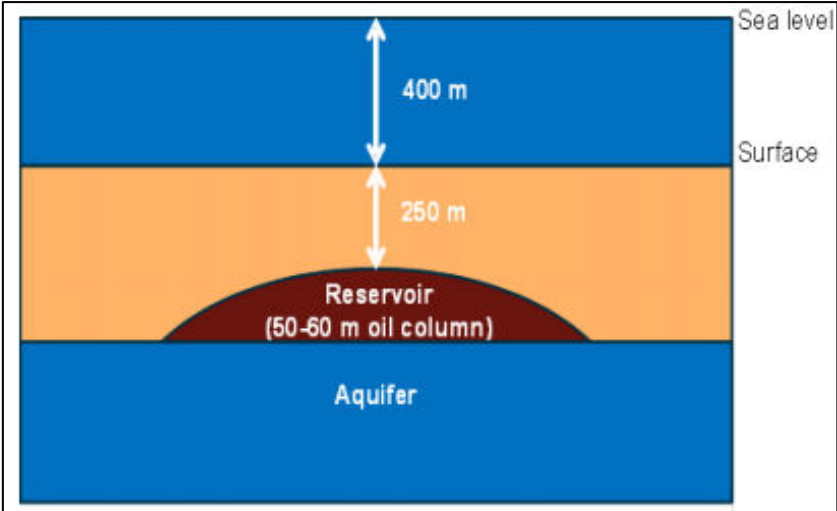

Figure 18 - Shallow reservoir situation scheme. [23]

This is an actual scenario that takes place in the Norwegian area of Barents Sea on Production License 537 operated by OMV Norge AS (Wisting Central prospect). Water depth on that particular area is 400 m. Below the seabed there is 250 m of Cretaceous formation followed by the reservoir with oil column height of 50 – 60 meters and aquifer below. [23] In the year 2013, wildcat vertical well 7324/8-1 has been drilled to explore the eventual production potential in this area.

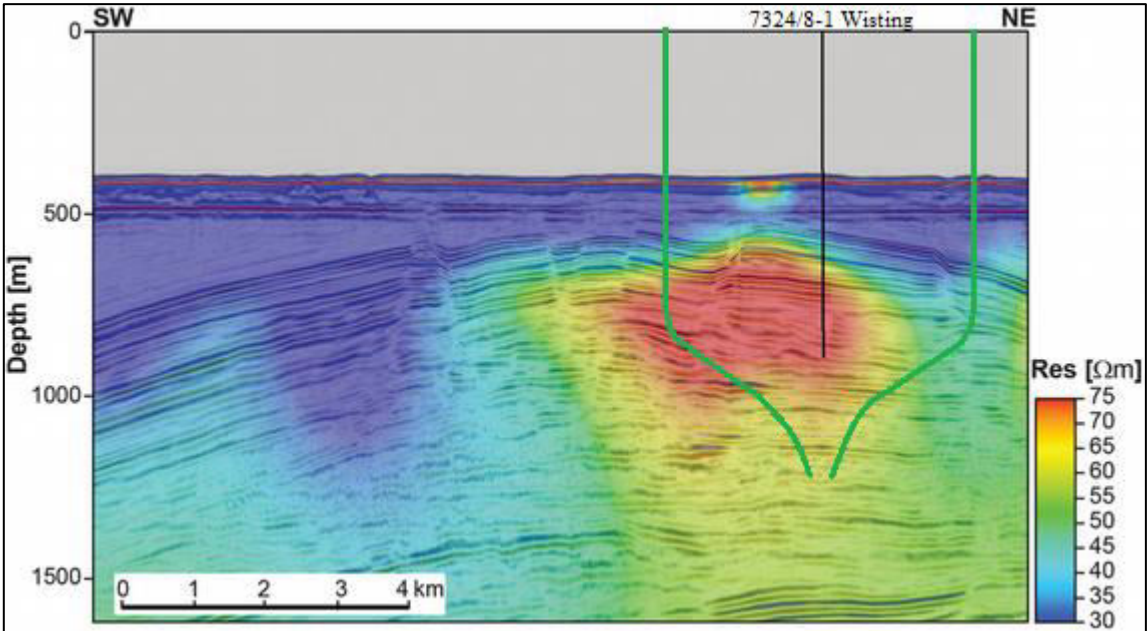

Figure 19 - Well 7324/8-1 with schematic relief wells. [24]

Figure 19 shows that the 7324/8-1 well has been drilled to the depth of nearly 1000 meters. In this Figure, one can also see two added trajectories of potential relief wells (green wells). As it can be seen from the Figure, the significant problem is that the wildcat well (7324/8-1) has small depth and the reservoir, marked in red on resistivity logging, is located shallow below the seabed. Noticing different scales on vertical and horizontal axes, it can be seen that a typical S-shaped relief well trajectory and design approach cannot be applied in this situation. It is impossible with relief well of standard S-shaped trajectory to successfully intersect with wildcat well, establish hydraulic communication and perform dynamic kill procedure in case of a blowing well scenario, as presented in the Figure 19. It was mentioned in the introduction that the distance between relief well and blowing well cannot be too big nor too small. From drilling practice it is known that while drilling a new well, one must drill it in vertical direction to set conductor and surface casing and then certain deviation from vertical direction can be gained. Limited Dogleg Severity (DLS) of drilling tools will also affect the potential trajectory of relief well.

In such situation, if one wants to design a relief well that will successfully reach the blowing well, intersect with it and create hydraulic communication between them, a different approach than a typical S-shaped relief well trajectory needs to be considered. This is the main problematics of this Thesis. Relief well location for such scenario will be chosen, a novel relief well design will be presented and a trajectory suitable for shallow reservoir will be proposed.

#### ***4 Chapter IV – Subject of the Thesis***

Main concern of this Thesis will be to propose a relief well design for a shallow reservoir scenario. As a case study, the situation on Barents Sea Production License 537 operated by OMV Norge AS will be carefully evaluated. Relief well location and design will be proposed for the wildcat exploration well 7324/8-1 drilled on Wisting Central Prospect. This prospect has been chosen as a shallow reservoir scenario example due to its unconventional character. The distance in vertical direction that allows to build the angle of the relief well is very small because the depth of the reservoir is very shallow. The idea behind this concept is that the relief well trajectory will be designed to go deeper than the depth of the reservoir. Then, it will start to gain inclination and return to shallower depth, where it will eventually intersect with the blowing well (hypothetically in this case well 7324/8-1). Such solution will result in unconventional and novel relief well trajectory that generally could be described as U-shaped. The TVD at the deepest point of the well will be bigger than the TVD of intersection point with the blowing well. This concept of relief well has been considered for shallow reservoirs and shallow wells before, but so far there is no information about any drilled or completed wells of such type. However, if the shallow reservoirs are to be accessed there is an urgent need to develop a relief well concept for such situations, capable of intersection at small depths.



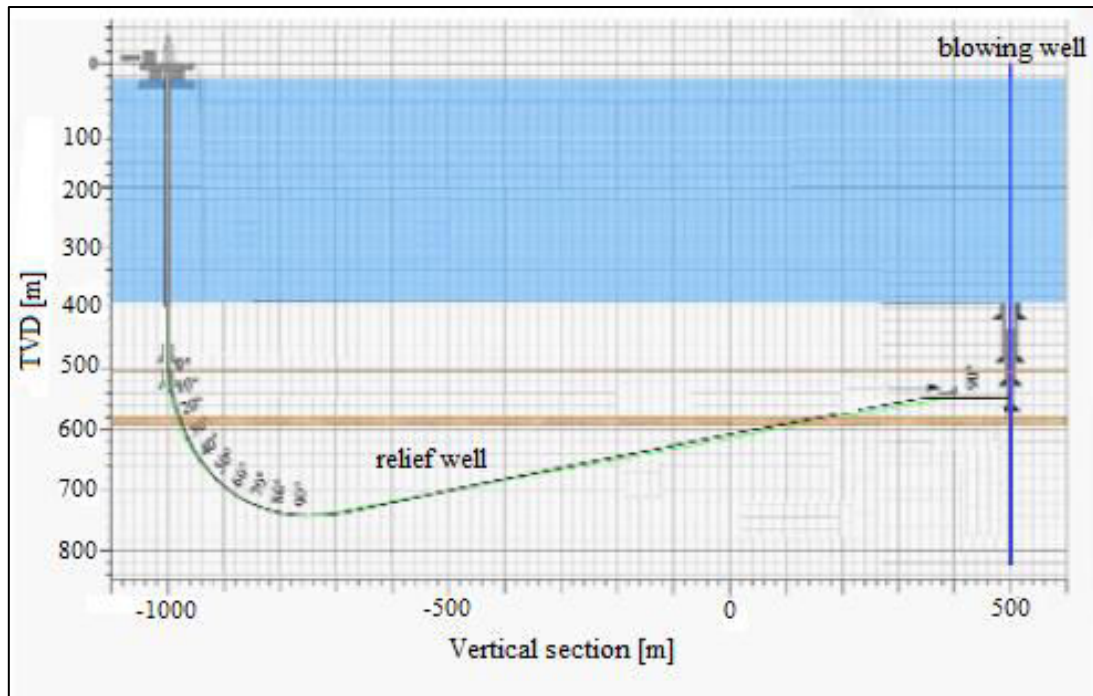

Figure 20 – Hypothetical relief well concept for a shallow reservoir. [25]

Concept similar to the one that will be considered in this Thesis is pictured in the Figure 20 above. Company Wild Well Control presented it as a viable method of well containment at shallow depths with shallow intersection points. [25] As it can be seen in the Figure, the situation somehow resembles the scenario that takes place on Wisting Prospect. Water depth is approximately 400 meters, the reservoir is located approximately 200 meters below the seabed. Blowing well is vertical with the last casing shoe set above the reservoir at TVD of approximately 570 meters. Then it intersects the reservoir rock at depth of nearly 600 meters and continues as open hole to TVD of 820 meters. Proposed trajectory of relief well is at first vertical and then, after the conductor and surface casing is set, it starts to build inclination. Well reaches its deepest point and from that moment on starts to go back to shallower depth with inclination bigger than  $90^\circ$ . It reaches the appropriate depth, localizes the blowing well, tracks it and intersects with it above the last casing shoe above reservoir.

## 5 Chapter V – Scenario Evaluation

This section is strongly based on references [23], [26], [27], [28].

Production license 537 is located in the southern part of Barents Sea, approximately 310 km to the north of Hammerfest, Norway. Covering the area of 429,6 km<sup>2</sup> it stretches between latitude of 73 – 74 degrees North and longitude 24 – 25 degrees East. OMV Norge AS is currently acting as an operator on that License and exploring the area in search of recoverable resources. The license area consists of two blocks: 7324/7 and 7324/8. [27]



Table 1 - Schedule of exploration work on PL 537. [27]

Wellbore	Wellbore name	Entered date	Completed date	Purpose	Content
<a href="#">7324/7-1 S</a>	Wisting Alternative	20.09.2013	03.11.2013	WILDCAT	SHOWS
<a href="#">7324/7-2</a>	Hanssen	13.04.2014	06.07.2014	WILDCAT	OIL
<a href="#">7324/7-3 S</a>		15.01.2016	in drilling	APPRAISAL	
<a href="#">7324/8-1</a>	Wisting Central	10.08.2013	17.09.2013	WILDCAT	OIL
<a href="#">7324/8-2</a>		26.04.2015	16.05.2015	WILDCAT	DRY

Well 7324/7-1 S was drilled to total depth of 2477 meters. Its objective was to test the formation for the presence of recoverable hydrocarbons accumulations. Some presence of hydrocarbons has been confirmed, which resulted in the summary that the well shows however, no major discovery has been made in that case. Wells 7324/7-2 and 7324/8-1 both proved the presence of recoverable hydrocarbon accumulations. Both are oil discoveries in homogenous sands of good reservoir properties with possible gas caps. Discovery from the well 7324/7-2 is said to contain approximately 20 – 60 mmbo (millions of barrels of oil), while discovery from the well 7324/8-1 is a major one as there are said to be 60 – 160 mmbo of recoverable oil there. [23] Both those discoveries can be seen in the Figure 22 presented as resistivity anomalies in 3D.

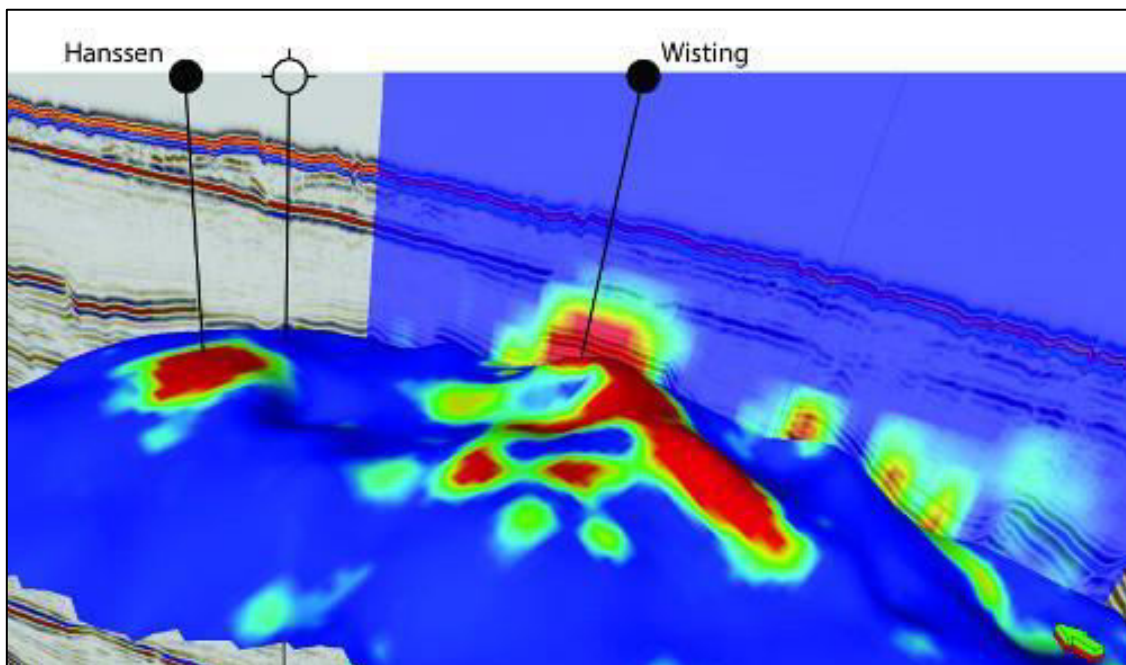

Figure 22 - 3D resistivity anomalies of Wisting and Hanssen discoveries. [29]

All 3 wells that confirmed the presence of hydrocarbons can be seen in the Figure 23.

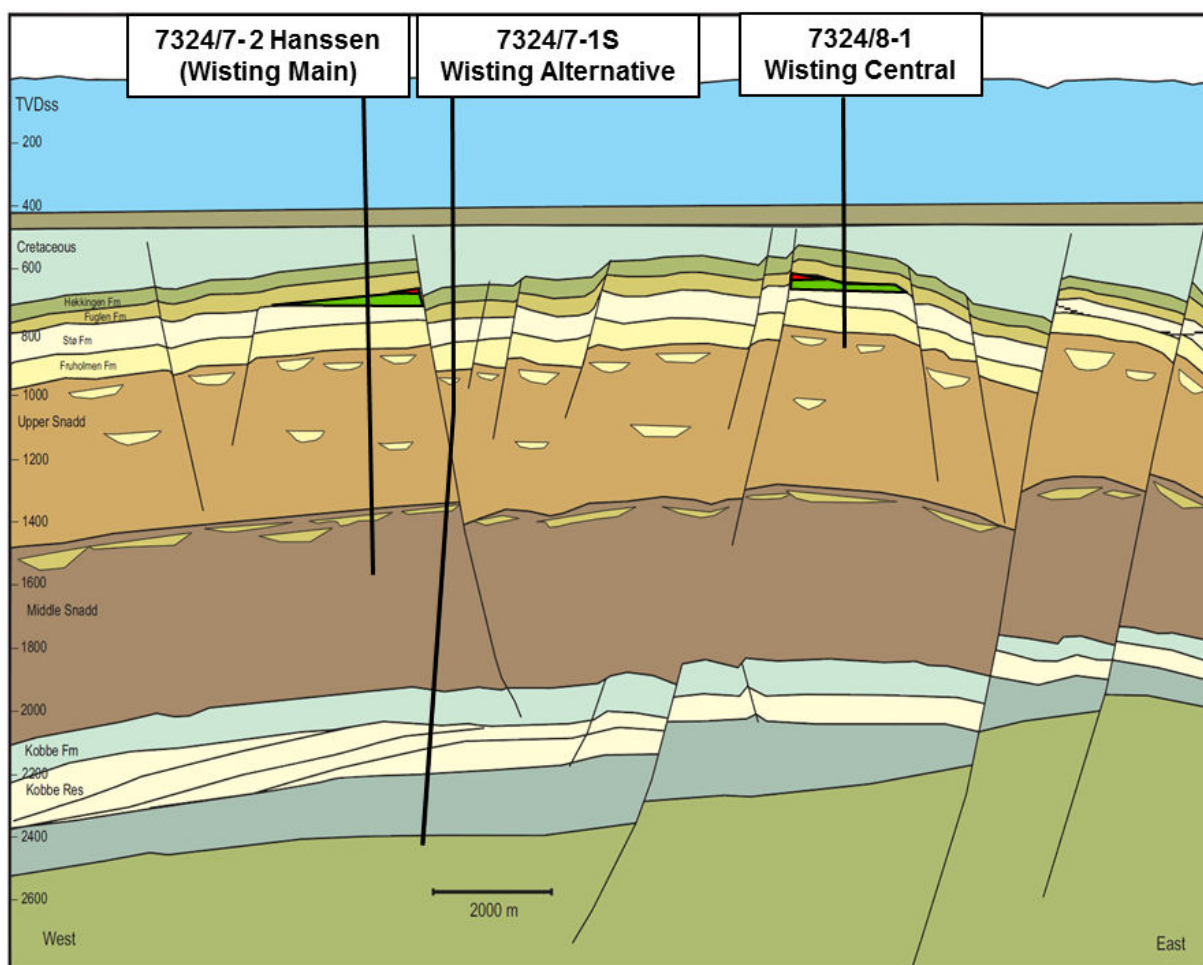

Figure 23 - Wet wildcat wells drilled on PL 537. [28]

However, well 7324/8-1 (Wisting Central) highlighted in yellow in Table 1 will be of great importance as this will be the well for which the relief well location, trajectory and design will be proposed. As it can be seen in the Figure 23, this is the most shallow well and the depth of the reservoir is the smallest.

### 5.1 Well 7324/8-1 (Wisting Central)

This section is strongly based on reference [27].

Well 7324/8-1 is a wildcat exploration well that was drilled as a first one on PL 537. It was drilled between August and September of 2013 to confirm the presence of hydrocarbons in Jurassic Realgrunnen Subgroup. The exact location of the well is presented in Figure 24 below (marked with red dot) and the exact coordinates are [27]:

- Latitude: 73° 27' 6.18" N
- Longitude: 24° 24' 15.42" E

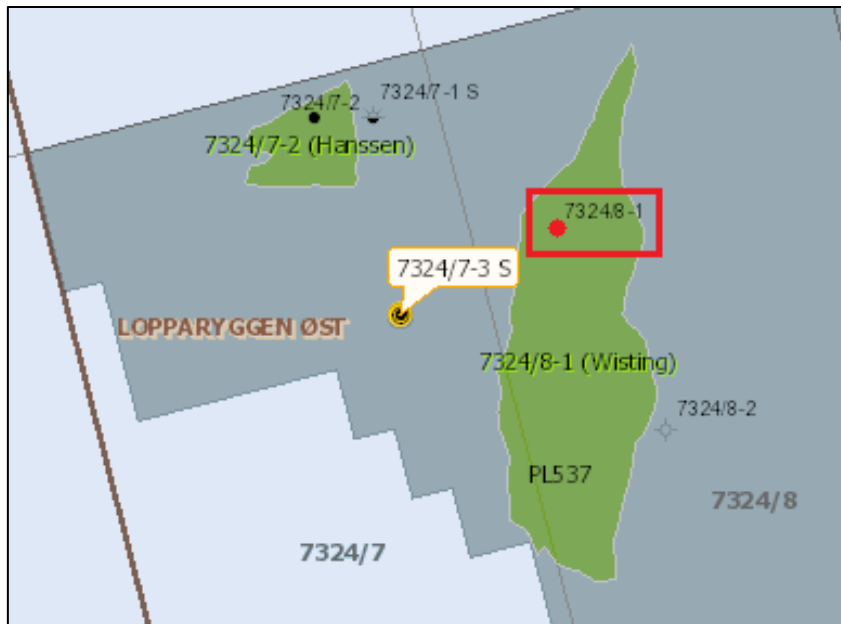

Figure 24 - Location of well 7324/8-1. [27]

Water depth in that particular location is 400 meters and the well was drilled to TVD of 930 meters. (Both measured in meters from Rotary Kelly Bushing – m RKB). Maximum inclination of that well is  $1,6^\circ$  so to simplify the considerations it will be assumed that the well is perfectly vertical and there is no inclination of the well trajectory. [27] Firstly the well was drilled through 250 meters of overburden formation (Hekkingen and Fuglen) to enter the reservoir and encounter the oil column in the upper Stø formation. The height of the column was approximately 50 – 60 meters. Below the reservoir the Oil-Water Contact (OWC) was detected – presence of aquifer. The well was then drilled further through the Fruholmen formation to finally reach its TVD of 930 meters in Upper Snadd formation. [23]

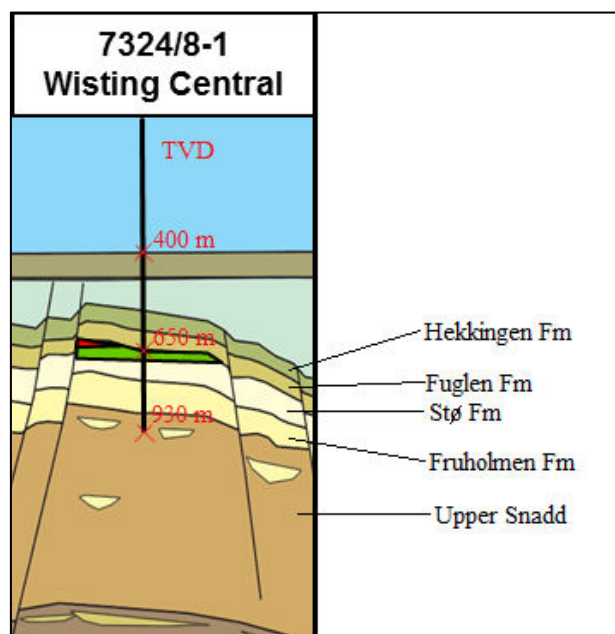

Figure 25 - Well 7324/8-1 profile. [28]

Coring was performed in the reservoir section of the well (Upper Stø Formation). Three cores have been cut and the Modular Formation Dynamics (MDT) oil samples have been taken. Reservoir pressure and temperature based on MDT data was estimated respectively to be [27]:

- 70 [bar]
- 17 [°C]

Pictured in the Figure 26 below is the possible 7324/8-1 well profile with schematic casing design and depths for each section. As there is no official information released regarding the exact well construction and it is not available, the following Figure was based on the information from [27].

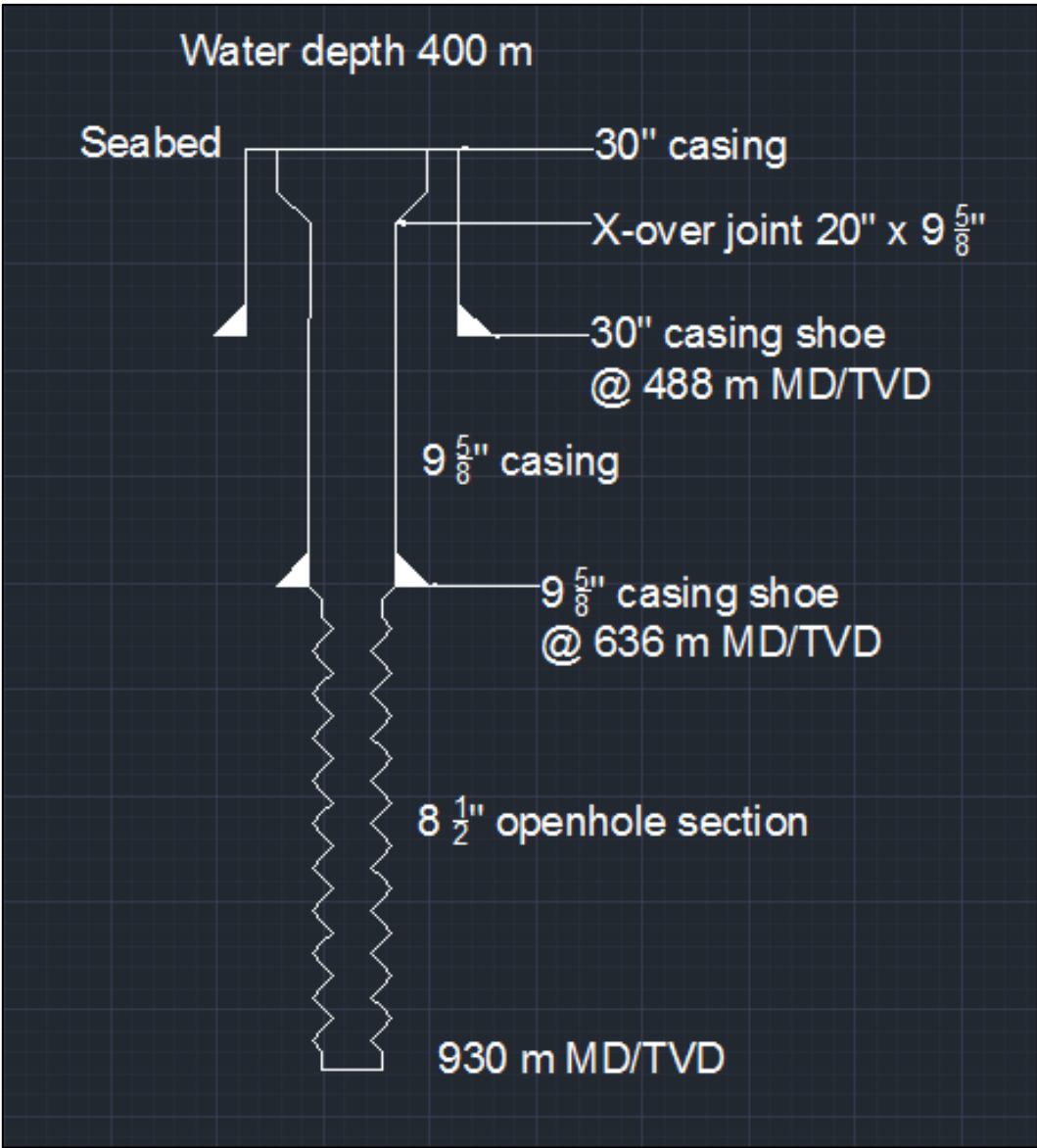

Figure 26 - Possible 7324/8-1 well profile.

Table 2 presented below shows the sequence of well 7324/8-1 completion. Firstly, the 9-5/8” pilot hole was drilled to 641 meters to check for the presence of shallow gas accumulations. No significant problems were encountered during drilling operations of that well. After drilling of pilot hole, the 36” hole was drilled to the depth of 488 meters to set the 30” conductor. Bentonite spud mud was used for drilling of this section. Then the 12-1/4” hole was drilled to the depth of 636 meters and the 9-5/8” casing was set in place. From that section on, the Glydril mud was used. After setting the 9-5/8” casing the last section of the hole was drilled. The 8-1/2” hole was then drilled through the reservoir rock and further on to the depth of 930 meters, which is the TVD of that well. This is an open hole section so no casing was set in place. [27]

Table 2 - 7324/8-1 well construction sequence. [27]

Casing type	Casing diam. [inch]	Casing depth [m]	Hole diam. [inch]	Hole depth [m]
CONDUCTOR	30	488.0	36	488.0
SURF.COND.	9 5/8	636.0	12 1/4	636.0
OPEN HOLE	-	930.0	8 1/2	930.0

As it can be seen from the Figure 26 the 8-1/2” section is drilled through the reservoir and further on. Such approach guarantees low blowout rates in case of lost well control. This hole size is also very common due to the requirements for data acquisition from the formation. The reservoir pressure is generally low ( 70 bar ) and the 9-5/8” casing was installed from the mudline way down and the casing shoe was set just before the well reaches the reservoir. According to [30] such well design should allow for the blowing well kill with only one relief well.

In further considerations such well construction as presented in Figure 26 will be assumed and the relief well will be designed for the exact location of the well 7324/8-1 as stated earlier and for such completion design as proposed above.

## ***6 Chapter VI – Relief Well Design***

Firstly, two suitable locations for relief wells will be proposed, as it is required by NORSOK Standard D-010. Then, for one of those locations, the relief well will be designed. Hypothetical trajectory of the well will be proposed and calculated. It will also be visualized in 3Ddrill and Landmark COMPASS modelling software along with the wildcat well. Parameters such as depths and lengths of various sections, inclinations, azimuths and DLS's will be calculated. Then, casing design for such well will be proposed, including sizes of various sections, lengths, casing shoe placement and other issues regarding this topic. It will be based on the concept of horizontal well designed for the same specific area of PL 537. Finally, the overall design of the well will be discussed in the next Chapter. Various challenges associated with such design will be pointed out and addressed. When available, possible solutions will be proposed and described.

### ***6.1 Relief well location***

Potential two relief well locations will be chosen according to following criteria:

- Infrastructure/operations placement,
- Seafloor topography,
- Distance from the blowing well,
- Water depth,
- Shallow dangers,
- Marine/meteorological data.

After two locations are chosen, relief well design will be proposed for one of them.

#### ***6.1.1 Infrastructure/operations placement***

Figure 27 shows the placement and presence of subsea infrastructure such as pipelines or flowlines around the Wisting prospect (well 7324/8-1 in particular). Well 7324/8-1 was the first well to ever be drilled in that location. As it can be seen in the Figure, there is no infrastructure connecting it to the shore and no permanent installations in the nearest surrounding of considered location. Due to the fact, that Wisting prospect is still in the phase of exploration and development, there are no production facilities there. Visible in the Figure are such fields as Snøhvit operated by Statoil and Goliat operated by Eni. Both surface facilities and pipelines can be seen in the Figure. The fact that well 7324/8-1 was the first one to ever be drilled on the Wisting prospect indicates that the eventual relief well placement would not be limited in any way by the presence of any type of subsea infrastructure or facilities.



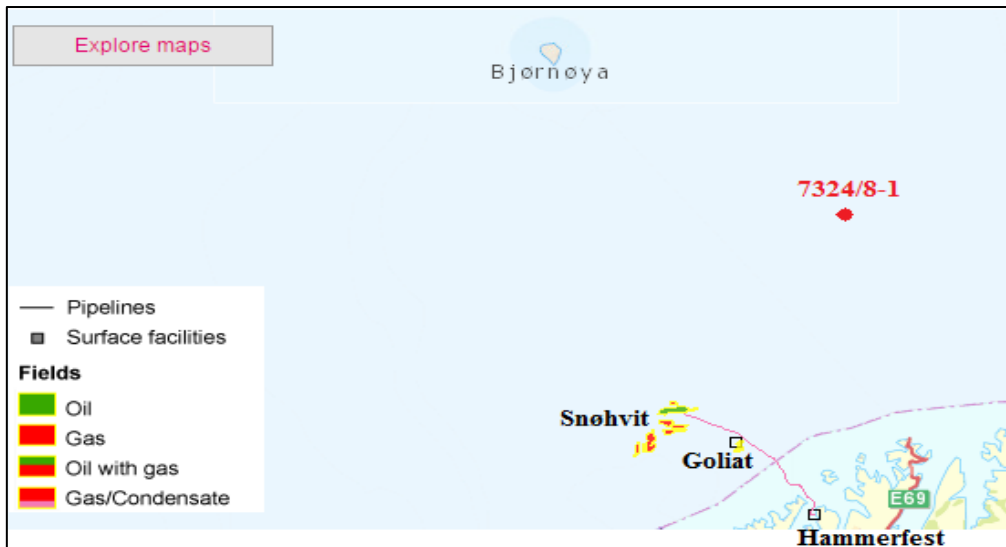

Figure 27 - Placement of subsea infrastructure nearby well 7324/8-1. [31]

Figure 28 presents the map of marine traffic and operations nearby the exact location of well 7324/8-1. Data regarding traffic density marked with dots and green gradient is shown as for the year 2013. It can be seen, that the density of traffic in that area was very low. There are no visible shipping lanes marked on the map in that area. Vessels marked in blue that can be seen in the Figure are associated with exploration of that prospect and are offshore supply vessels or standby safety vessels. Vessel marked in red (Staalbas) is a fishing vessel but the distance between well location and vessel location is greater than 8 kilometers. The red circle marked on the map indicates the area of 2 kilometers around the well. [32]

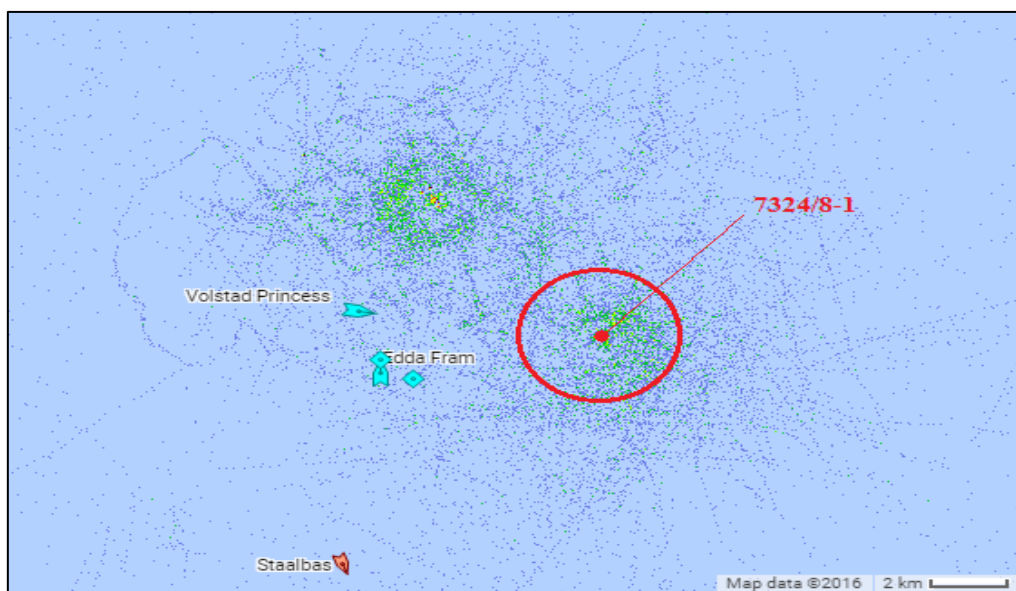

Figure 28 - Map of marine traffic & operations nearby 7324/8-1 well. [32]

Figures 27 and 28 indicate that the relief well position will not be restricted or anyhow affected by marine traffic or existing offshore infrastructure or installations.

6.1.2 Seafloor topography

In the Figure 29 one can see the bathymetric map of the seafloor in that area. The Figure shows that water depth in the direct location of the well is approximately 400 meters. Generally speaking, the seafloor topography in that area is very regular. Seabed is rather flat, there are no slopes or knolls. No significant variations in elevation. It can be seen, that in the eastern direction from the well there is a small knoll. On the distance of approximately 7 kilometers the difference in elevation is 50 meters. However, when from that data the dip angle of the seabed is calculated, it is smaller than 0,5°. Seafloor topography then will not limit the location of potential relief wells whatsoever.

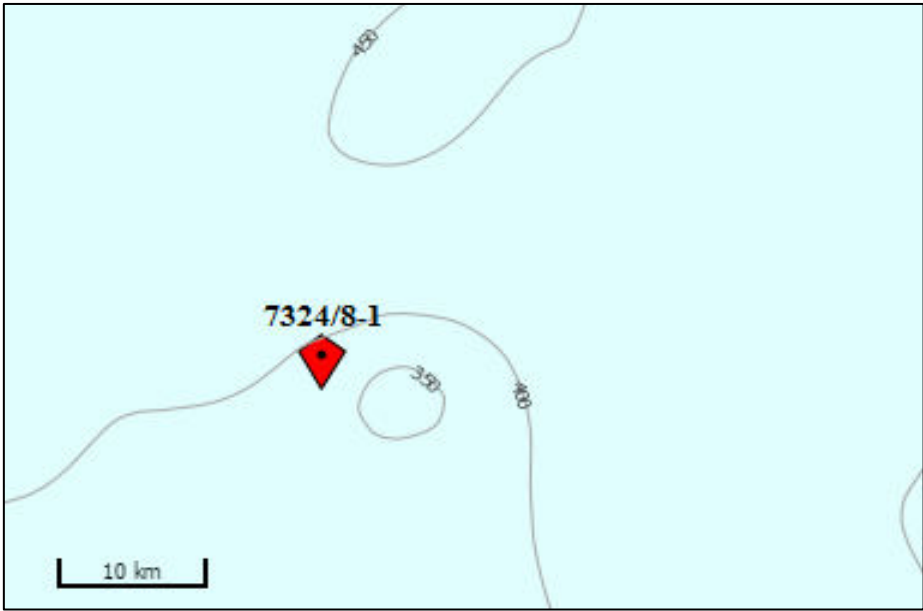

Figure 29 - Bathymetric map of seafloor topography around well 7324/8-1. [33]

6.1.3 Distance from the blowing well

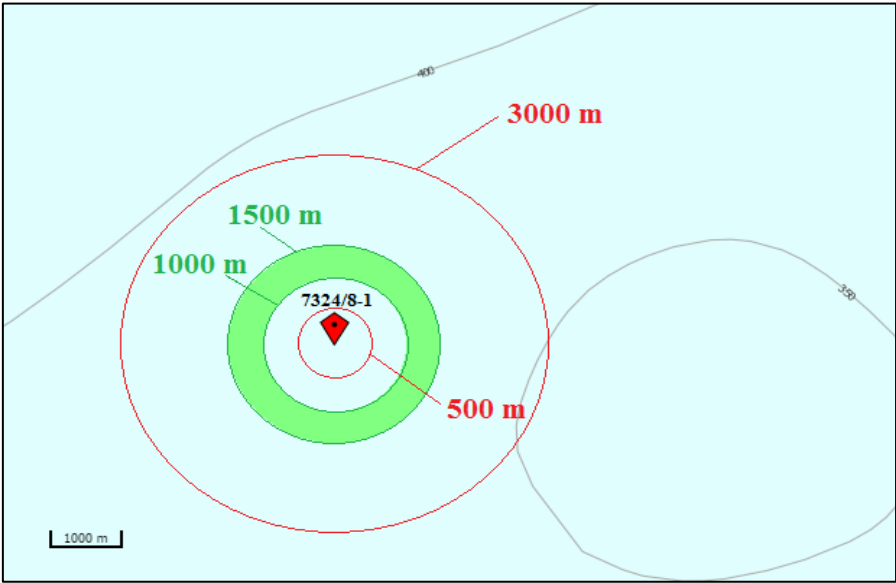

Figure 30 - Distance from well 7324/8-1 with no-go zones.

Figure 30 shows the exact position of the well with circles picturing various offset distances from the well. No-go zones are marked with red circles of radii respectively 500 m for the small one and 3000 m for the large one. It means that relief well cannot be placed closer than 500 m and further than 3000 m from the blowing well. Most common location for a relief well placement is a green area between circles of radii 1000 m and 1500 m. Generally, distance between relief well and 7324/8-1 well should be somewhere in that range or deviate from it slightly.

**6.1.4 Water depth**

In that particular case water depth is fairly typical. Neither are those deep water conditions, as NORSOK Standard D-010 defines deep water as water depth larger than 600 meters, nor is it a very shallow water depth. From the Figure 29 shown above in point 6.1.2, one can see that in every direction from the well water depth is approximately between 350 – 400 meters. In such case, water depth will not affect the possible location of relief well. However, relief well would have to be drilled from semi-submersible vessel.

**6.1.5 Shallow dangers**

Presence of shallow gas accumulations will not necessarily affect potential location of relief wells, but rather the process of drilling it. If there is a danger of shallow gas presence in the area, the process of drilling of each well section will firstly require to drill a small pilot hole (for example 9-5/8”) that will allow for a fast well kill in case of encountered shallow gas. Figure 31 presents the resistivity survey for that area performed on the line SW-NE. Approximately 1 kilometer to the SW from the well 7324/8-1 there is a small, visible resistivity anomaly that can be considered as a shallow gas accumulation. If possible, relief well should not be drilled through that accumulation.

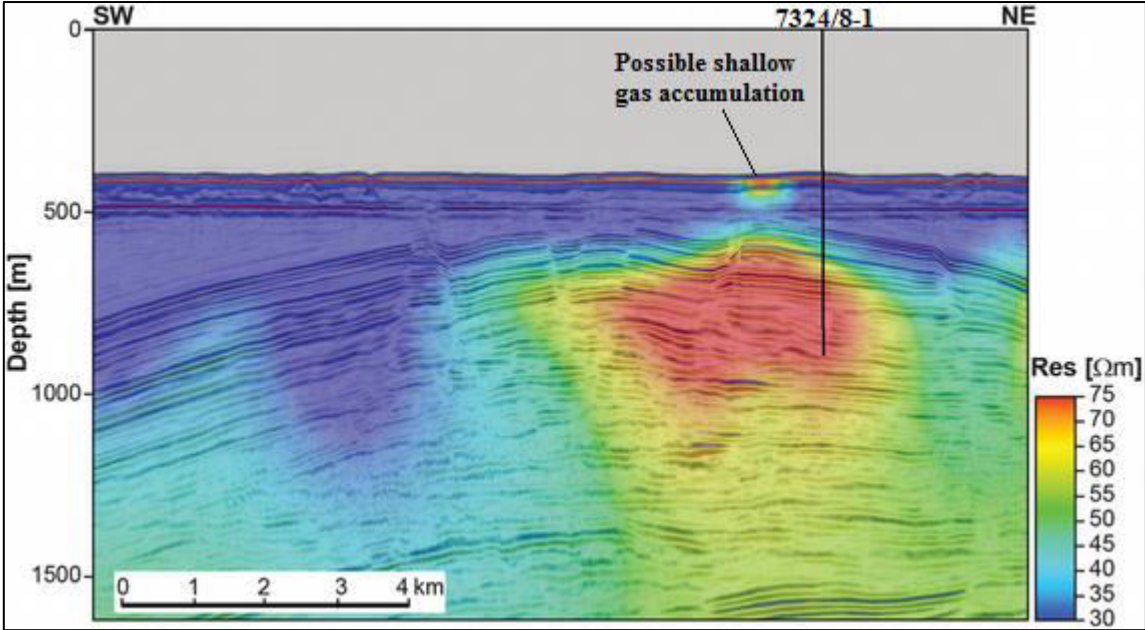

Figure 31 - Geophysical resistivity survey for considered location. [24]

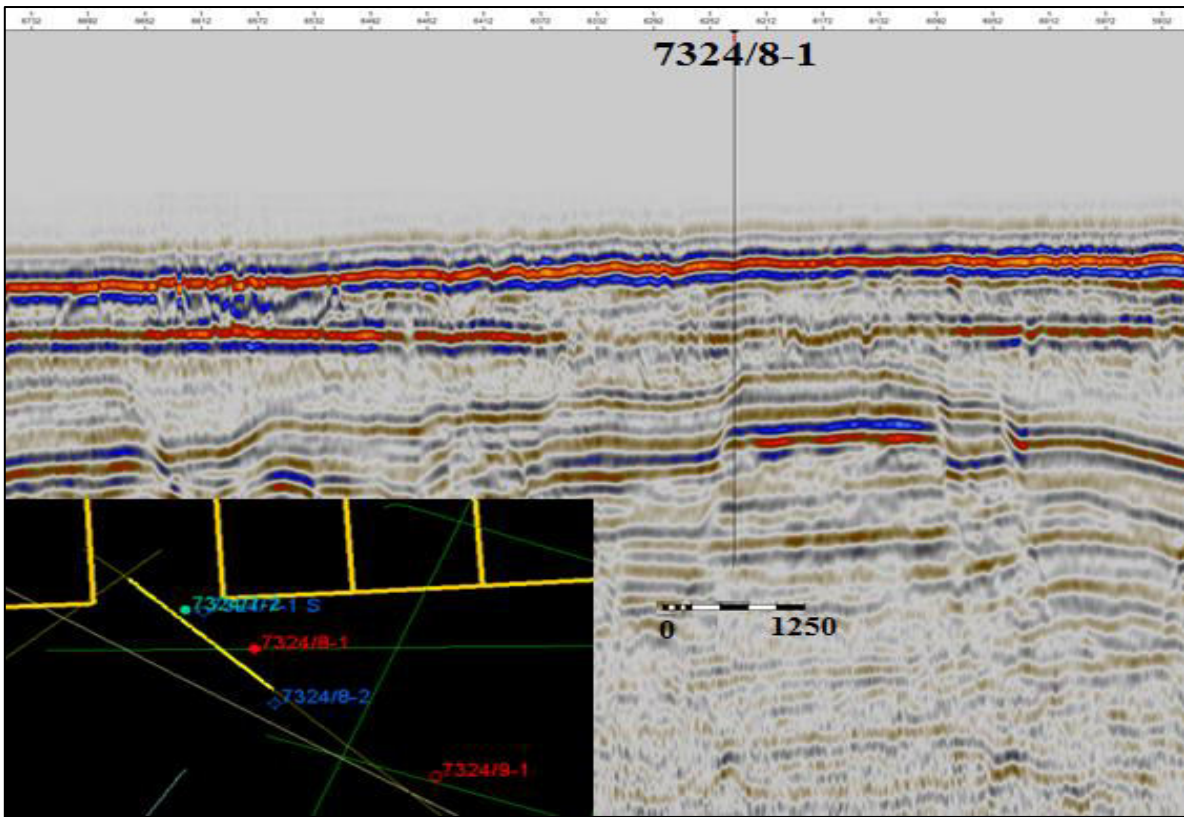

Figure 32 - Geophysical survey for considered location NW-SE. [35]

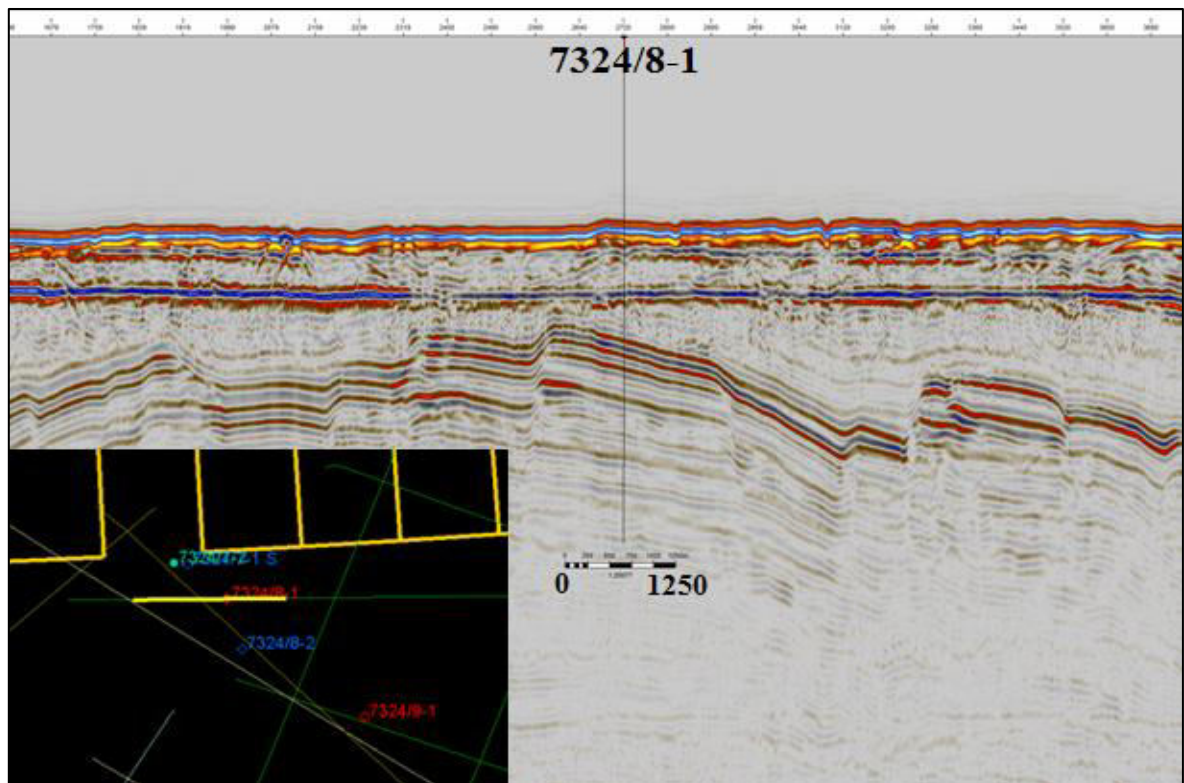

Figure 33 - Geophysical survey of considered location W-E. [35]

Figures 32 and 33 show geophysical surveys of the area around the well 7324/8-1. It can be seen from those Figures that there are no visible shallow gas indications around the well. It should be safe to assume that directions NW-SE and W-E from the well 7324/8-1 can be considered as potential good positions for relief well location. However, it is known that there are shallow gas accumulations in the area of PL 537 that is why adequate drilling techniques must be implemented. Also, one should avoid drilling a relief well through the shallow gas accumulation visible in Figure 31 to the S-W of well 7324/8-1. [35]

**6.1.6 Marine/meteorological data**

While considering relief well location strong emphasis must be put on marine and meteorological conditions in the area. Data regarding wind direction and sea current direction are vital for the correct placement of relief wells. It is also a very common practice to perform various simulations of eventual blowout and oil spill in conditions reflecting actual conditions in that location, including actual oil properties, reservoir properties and common environmental conditions. [23]

Figure 34 shown below presents the wind direction with the location of well 7324/8-1 marked with green circle. As it can be seen from the Figure, direction of the wind in that area is strongly northern ( $175^\circ$  measured clockwise from S) without any visible transitions. Therefore, due to the wind direction, one should avoid placing relief wells to the north of the well 7324/8-1. [16]

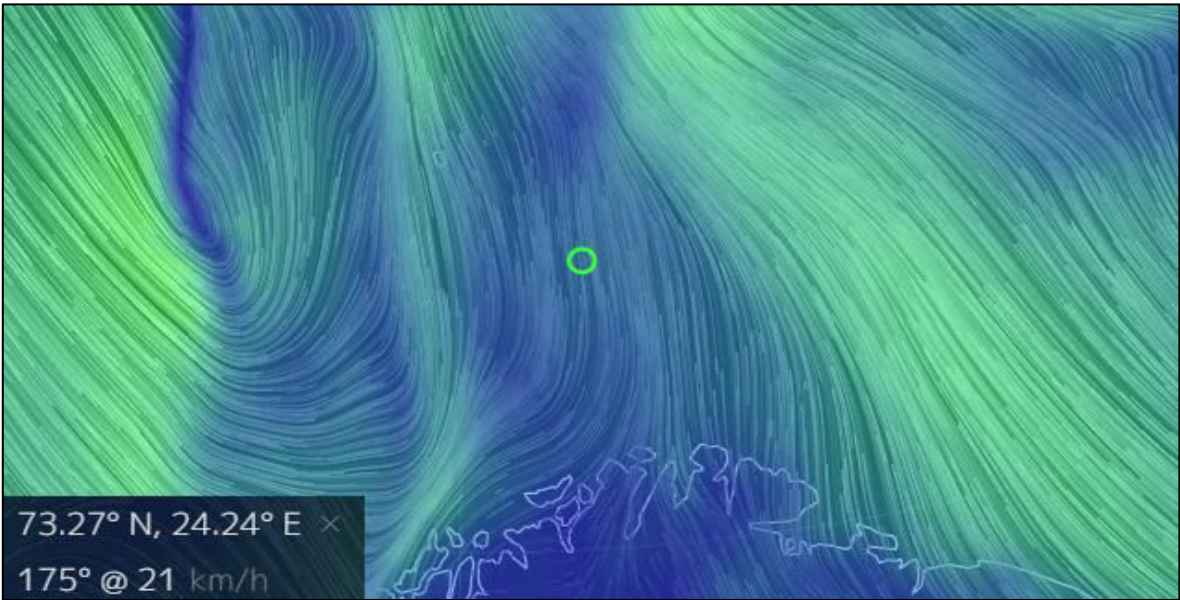

Figure 34 - Wind direction map. [34]

Figure 35 presents the direction of sea currents occurring in the considered area. Location of well 7324/8-1 is marked with green circle. Taking into account the sea current direction ( $285^\circ$  measured from S clockwise), one should avoid placing relief wells in the area to the east from the well 7324/8-1. Relief wells should be localized up-wind and up-current from the potential blowing well position. [16]

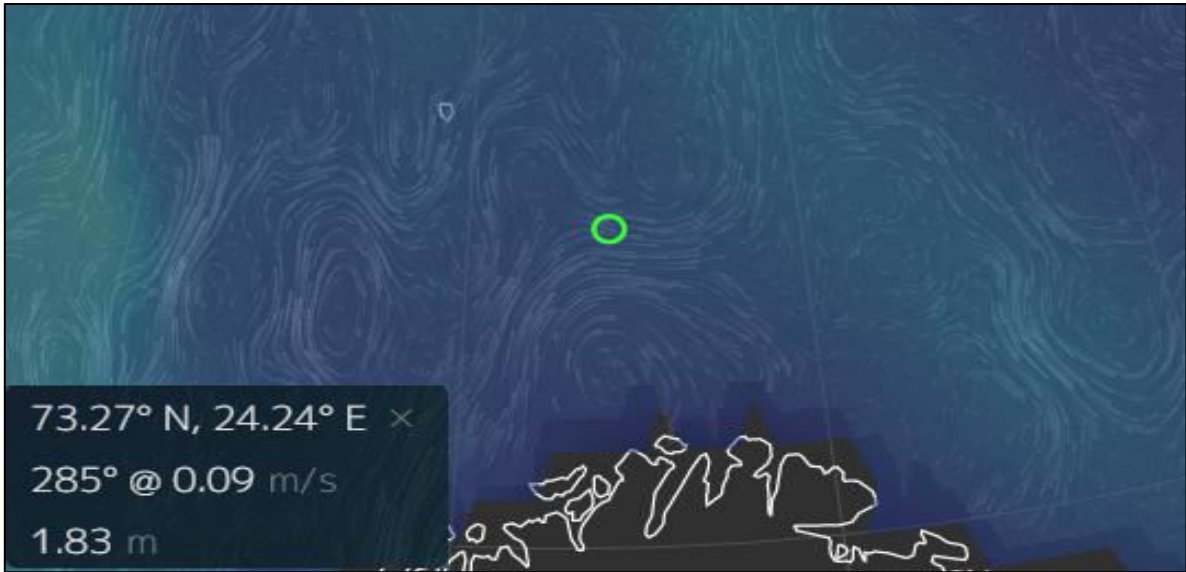

Figure 35 - Sea current map. [34]

Figure 36 is a graphical illustration of blowout and oil spill simulation performed for the Wisting Prospect by OMV Norge AS. Wind and sea current are main factors affecting eventual direction of oil spill in case of a blowout scenario. As it can be seen in the Figure, in case of a blowing well scenario, hydrocarbons will most likely migrate towards east (along the sea current direction) and to the north (along the wind direction).

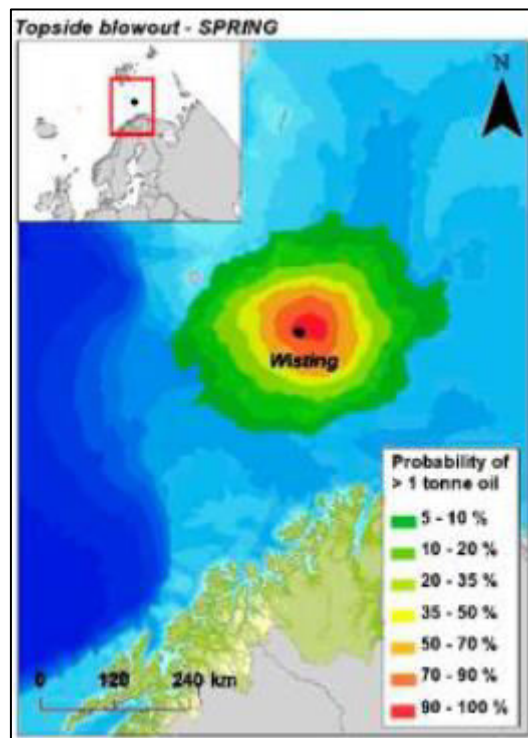

Figure 36 - Simulation of blowout and oil spill. [23]

Taking into account criteria regarding marine and meteorological conditions eventual relief well must not be placed to the north/north-east/east in reference to the well 7324/8-1. Therefore, eventual relief well should preferably be placed to the north-west/west/south-west/south from the well 7324/8-1.

### 6.1.7 Relief well location

Taking into account all criteria mentioned in section 6.1 eventual positions of two relief well locations can be proposed. As it was pointed out earlier, infrastructure/operations placement will not limit eventual location whatsoever. Seafloor topography will not affect it in any way as well. However, distance between well 7324/8-1 and potential relief wells should be rather typical ( 1000 – 1500 meters ) or deviate from it slightly. Water depth has no actual influence on relief well position in that case. Due to the presence of shallow gas accumulations, one should avoid drilling of relief well in the S-W direction from the well 7324/8-1. There are no more visible shallow gas accumulations on geophysical surveys however, it should be assumed that while drilling, such dangers can be encountered and suitable drilling procedures should be implemented. Finally, due to the marine/meteorological conditions in considered area, relief wells should not be placed to the north/north-east/east from the well 7324/8-1 due to wind and sea current direction.

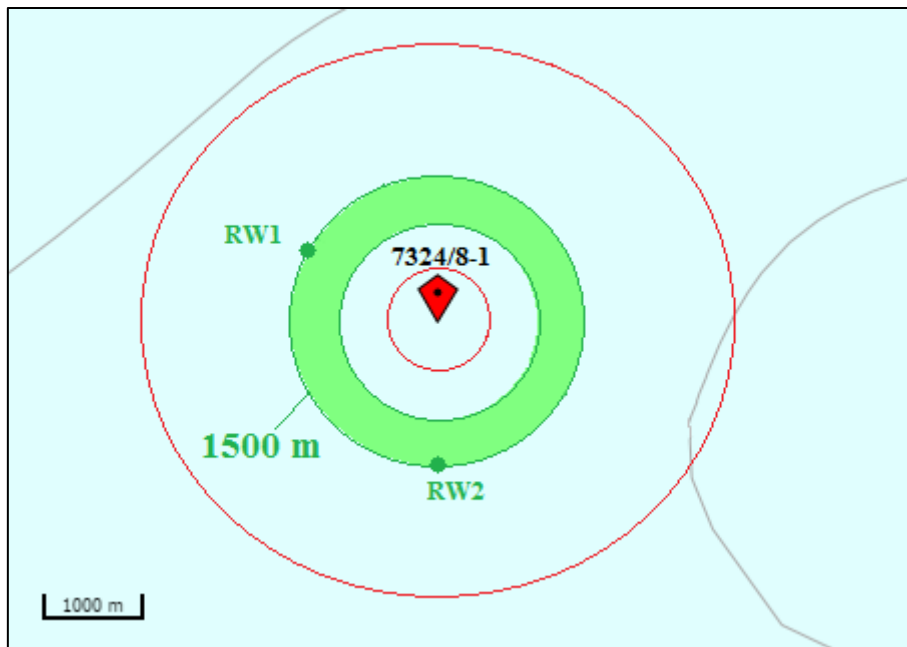

Figure 37 - Potential relief well locations.

Figure 37 presented above shows two potential locations for relief well placement in reference to well 7324/8-1. Both locations are 1500 m away from the wildcat well. RW1 is located to the east and slightly to the north from the wildcat well on the azimuth of approximately 305°. Location RW2 is to the south from the wildcat well on the azimuth of 180°.

Further considerations and design will be proposed for location RW2, to the south of well 7324/8-1.

## 6.2 Relief well trajectory

Before proposing and calculating relief well trajectory, several aspects and values must be taken into consideration in order for relief well to successfully reach the ‘blowing well’ and intersect with it:

- horizontal displacement between relief well and ‘blowing well’ is 1500 meters,
- relief well will be drilled in the northern direction (azimuth 360°),

Relief well trajectory will be also limited by the position of intersection point with the ‘blowing well’, by dogleg severity (DLS) and by the inclination of relief well straight section at intersection.

### 6.2.1 Intersection point

As pointed out in the theoretical introduction to this Thesis, there are certain rules that have to be applied to ensure the correct choice of intersection point between relief well and ‘blowing well’. To successfully kill the well, intersection should take place above the reservoir zone. Moreover, the intersection point should normally be located approximately 100 ft ( roughly 30 meters ) from the last casing shoe of the ‘blowing well’.[13] In case of the well 7324/8-1, casing shoe of the 9-5/8” section is located at TVD of 636 meters (236 meters below seabed). Casing shoe is placed before the well enters the reservoir zone. Taking all above into consideration the depth of intersection point will be chosen:

- depth of intersection point will be 606 meters TVD (206 meters below seabed).

Intersection above the last casing shoe of ‘blowing well’ creates additional obstacle such that the hydraulic communication will be obtained by milling through the casing, but this practice will allow for better tracking and localizing of the blowing well, as it is explained further in this Thesis.

### 6.2.2 Dogleg Severity (DLS)

Dogleg severity defines the combined change in azimuth and inclination of well trajectory per length unit. In this case, dogleg severity will be equal to build rate, as only the well inclination changes (azimuth of relief well is constant, well does not change geographical direction, no deviation from azimuth 360°). There are no general rules regarding the optimal value of build rate in build section of U-shaped wells as it is quite a novel concept. However, as the trajectory of the proposed well is somehow similar to horizontal well trajectory, build rates for horizontal wells can be evaluated to choose a realistic build rate value. [36]

<b>HORIZONTAL-WELL CLASSIFICATIONS</b>			
<u>Well Type</u>	<u>Build Rate (ft)</u>	<u>Radius (m)</u>	<u>Radius (ft)</u>
Long radius	2 to 6°/100 ft	900 to 290	3,000 to 1,000
Medium radius	6 to 35°/100 ft	290 to 50	1,000 to 160
Short radius	5 to 10°/3 ft	12 to 6	40 to 20

Figure 38 - Build rates in horizontal wells. [36]



As it can be seen in the Figure 38, depending on the well type, different build rates are being used. Starting from very small build rates of  $2^\circ/100$  ft for the long radius wells, up to short radius wells of very high build rates per 100 ft. As the aim for the relief well concept proposed in this Thesis is to be within realistic boundaries, the following allowed dogleg severity will be chosen:

- DLS of approximately  $6^\circ/100$  ft (  $5,9055^\circ / 30$  m ) will be used in this relief well design.

### 6.2.3 Inclination

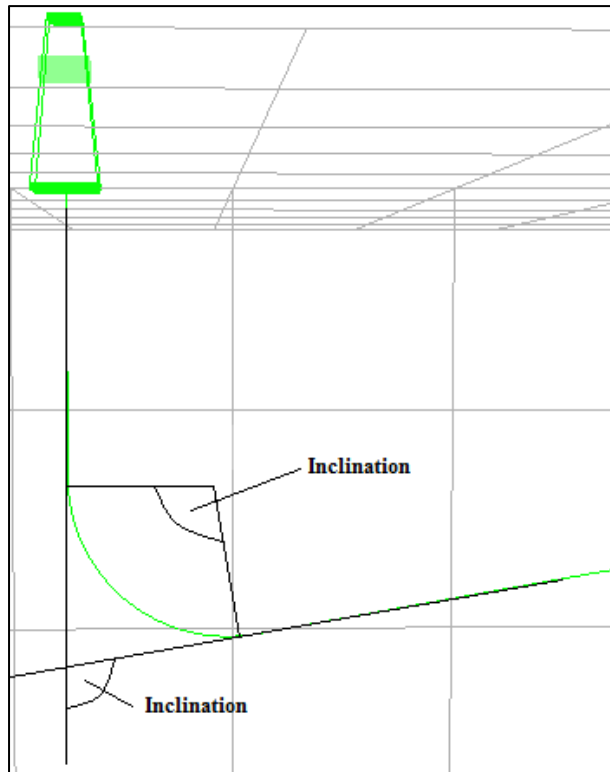

Figure 39 - Well inclination angle.

Another dimension that will limit potential relief well trajectory is an inclination at which intersection will take place. Inclination is an angle between vertical direction and tangent to the well axis. Figure 39 shows an inclination angle of the relief well. In case of U-shaped wells, inclination of second straight section will be greater than  $90^\circ$ . According to [30] it is advised that such wells should have inclination of approximately  $100^\circ$  at intersection point. Therefore, in further calculations:

- Inclination at intersection point is  $100^\circ$

### 6.2.4 Trajectory proposition

In the paragraphs above, certain design boundaries for the relief well trajectory have been pointed out and certain values determined:

- Horizontal displacement – 1500 meters to the south
- Azimuth of relief well –  $360^\circ$
- Inclination in hold section (3) and at intersection point –  $100^\circ$
- Depth of intersection point – 606 m TVD (206 m below the seabed)
- DLS – approximately  $6^\circ/100$  ft =  $5,9055^\circ/30$  meters

After careful evaluation of those figures a proposed trajectory for the well can be given, which will be followed by detailed calculations to check whether those expectations have been met.

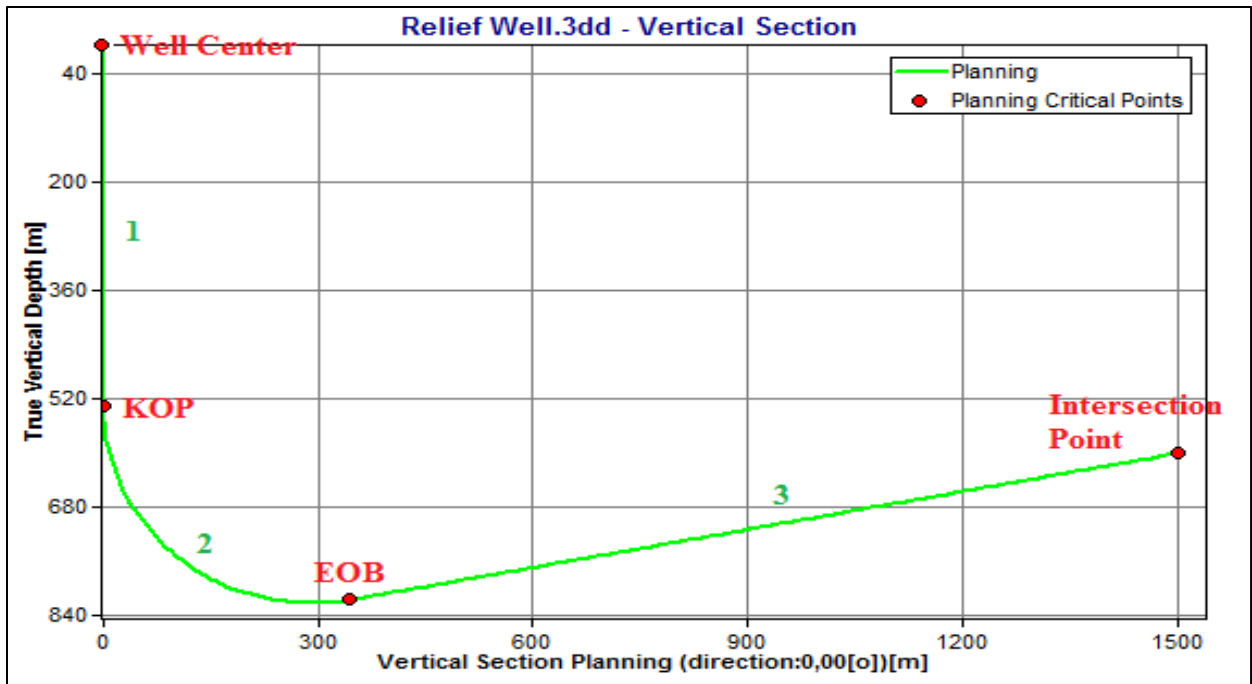

Figure 40 - 2D vertical plan of relief well trajectory.

Figure 40 shows the 2D vertical section plan of relief well with critical points marked. As it can be seen in the Figure, relief well trajectory will consist of 3 sections: straight vertical section (1), build section (2) and straight, inclined hold section (3). Critical points have been marked as well. Kick-off Point (KOP) is the point where well starts to build angle and gains inclination. End of Build (EOB) is the point where build section (2) ends. From this point well inclination does not change. Depth of KOP will be greater than 520 m TVD, depth of EOB will be smaller than 840 m TVD. Intersection point depth is 606 m TVD. This results in a U-shaped relief well trajectory.

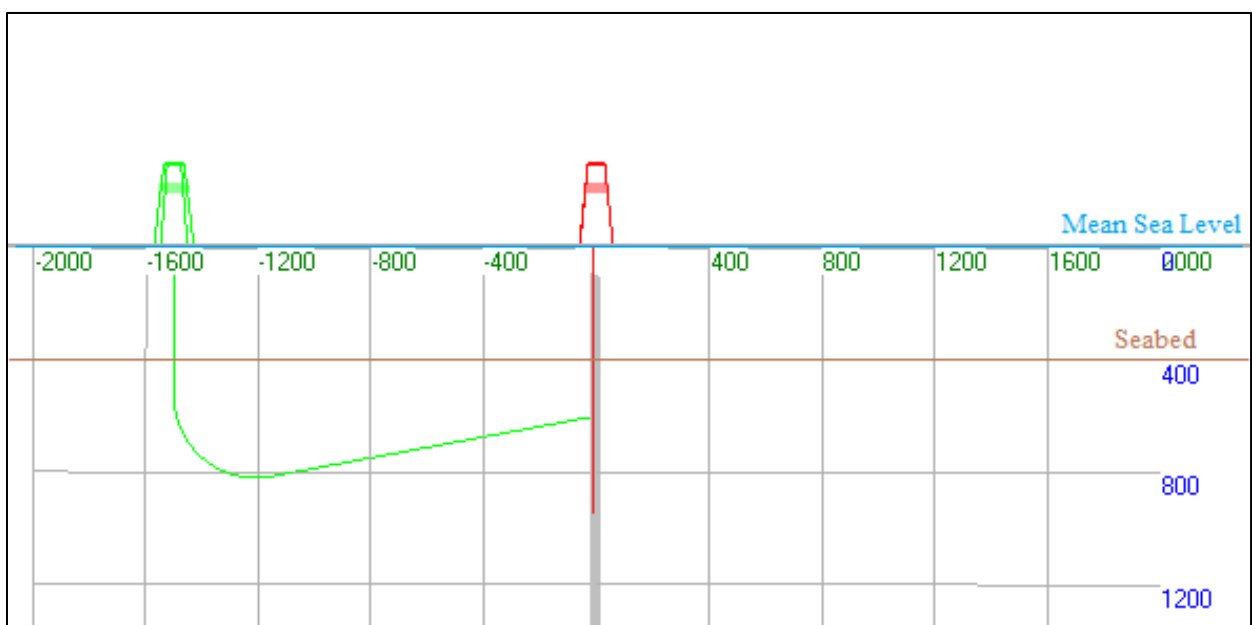

Figure 41 - Relief well and 7324/8-1 well on 2D vertical plane.

Figure 41 and 42 show both relief well (green) and well 7324/8-1 (red) on a 2D and 3D plane. Wells are showed in reference to each other. Trajectories of both wells can be seen, their spatial placement and location of intersection point as well.

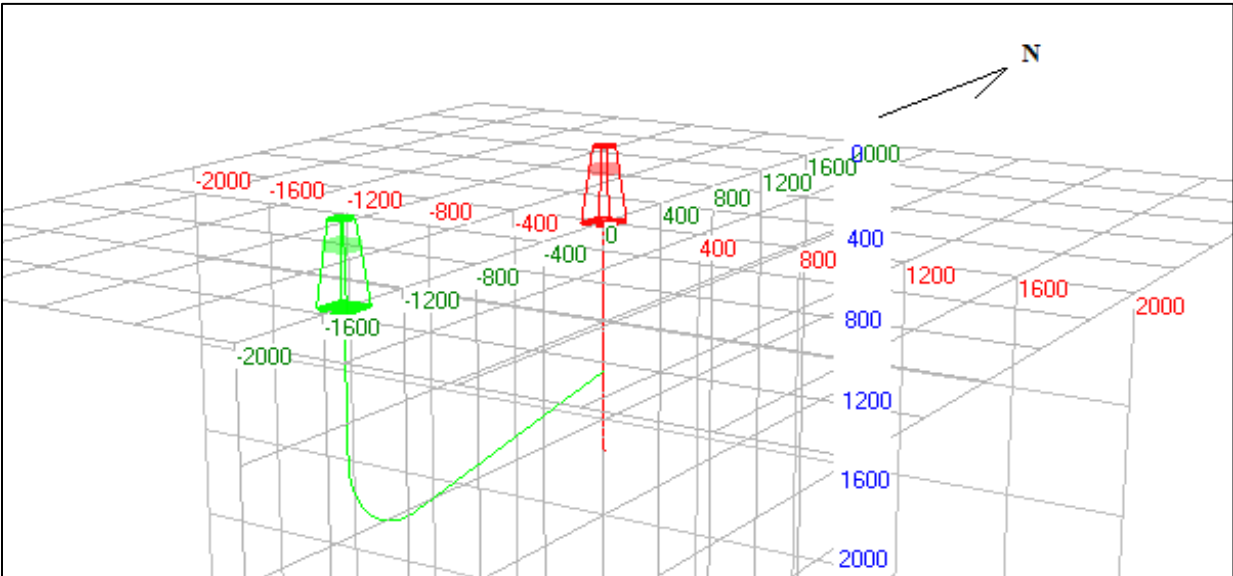

Figure 42 - Relief well and well 7324/8-1 on 3D plane.

6.2.5 Trajectory calculations

Proposed relief well trajectory can be seen in the paragraph 6.2.4 above. Also, there are certain limitations within which the trajectory has to be designed in order to successfully reach the target, which were also determined in the previous paragraph. Those values and trajectory requirements serve as a starting point for further calculations in this paragraph. Figure 43 shows the relief well trajectory scheme that will be used in further calculations.

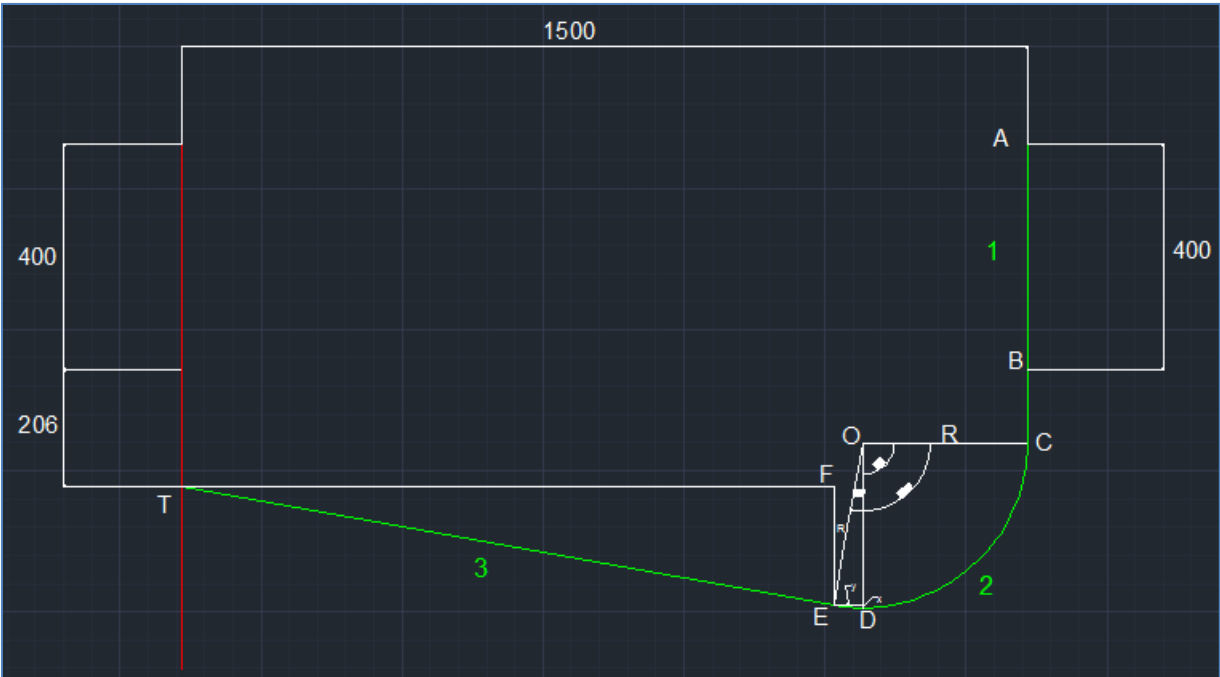

Figure 43 - Relief well trajectory with values.

Geometrical formulas used in calculations have been mathematically derived. Derivations of those formulas can be found in the Appendix 1 in the enclosure to this Thesis.

6.2.5.1 Calculation of radius (R) of Build section (2)

Dogleg severity: 
$$\frac{\Delta i}{\Delta l} = \frac{6^\circ}{100ft} = \frac{5,9055^\circ}{30m}$$

Derived formula for radius R: 
$$R = \frac{180^\circ}{\pi} \cdot \frac{\Delta l}{\Delta i} \quad (1)$$

Radius (R) of Build section (2): 
$$R = \frac{180^\circ}{\pi} \cdot \frac{30 m}{5,9055^\circ} = 291,06 m$$

6.2.5.2 Calculation of Build section (2) values x and y

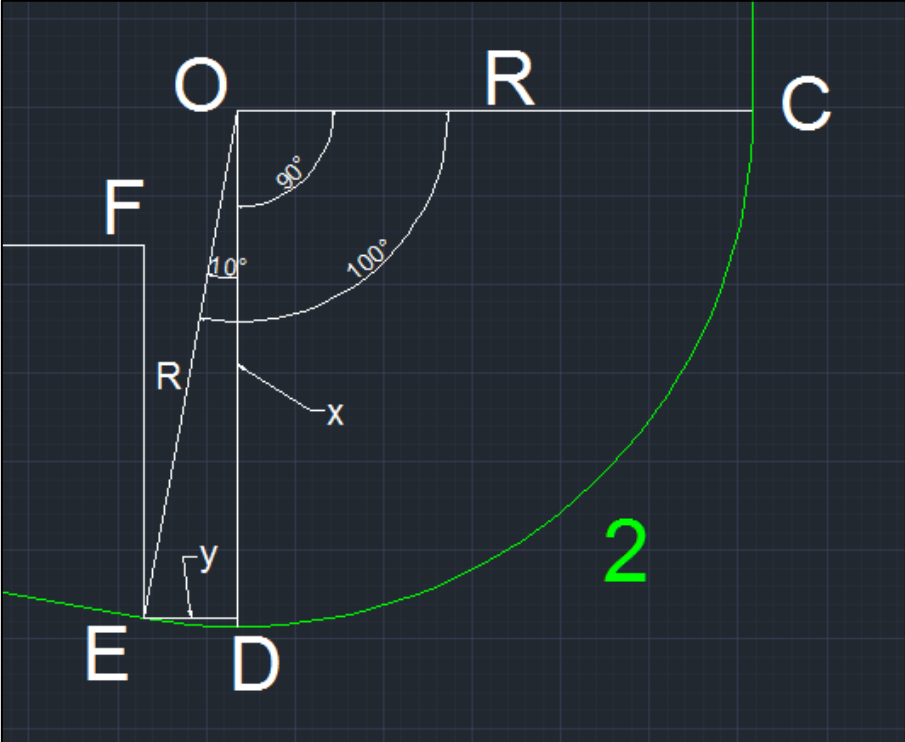

Figure 44 - Relief well build section (2).

Derived formula for x: 
$$x = R \cdot \cos\alpha \quad (2)$$

Derived formula for y: 
$$y = R \cdot \sin\alpha \quad (3)$$

Calculation of α: 
$$\alpha = 100^\circ - 90^\circ = 10^\circ$$



6.2.5.4 Calculation of well deepest point

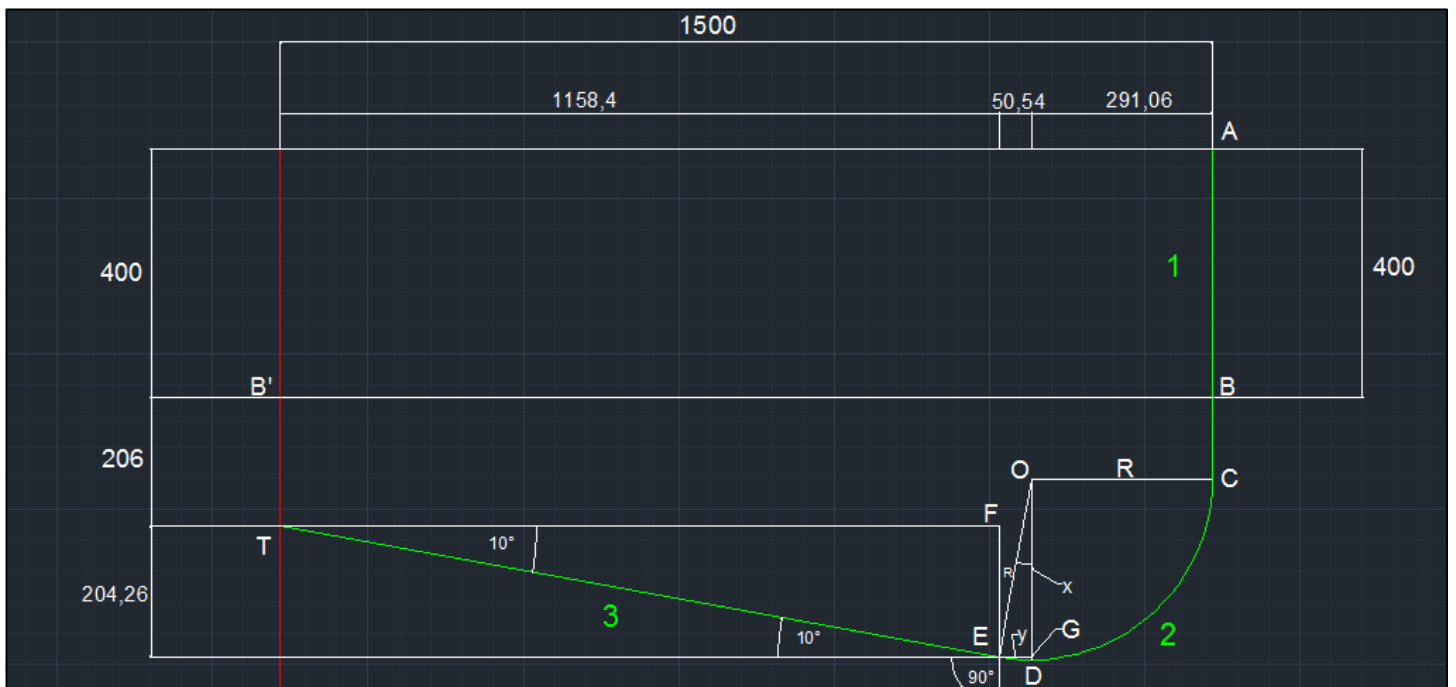

Figure 46 - Relief well with lengths.

Formula for deepest point:  $TVD = AB + B'T + EF + GD$

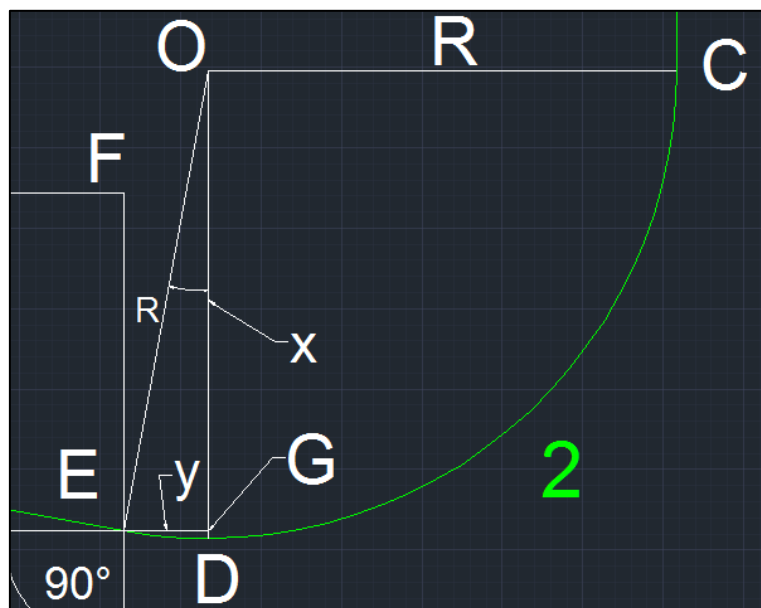

Figure 47 - Relief well deepest point.

Formula for GD:  $GD = R - x$

Calculation of GD:  $GD = 291,06 \text{ m} - 286,64 \text{ m} = 4,42 \text{ m}$

Calculation of deepest point:  $TVD = 400 + 206 + 204,26 + 4,42 = 814,68 \text{ m}$

6.2.5.5 Calculation of relief well KOP depth and total well Measured depth (MD)

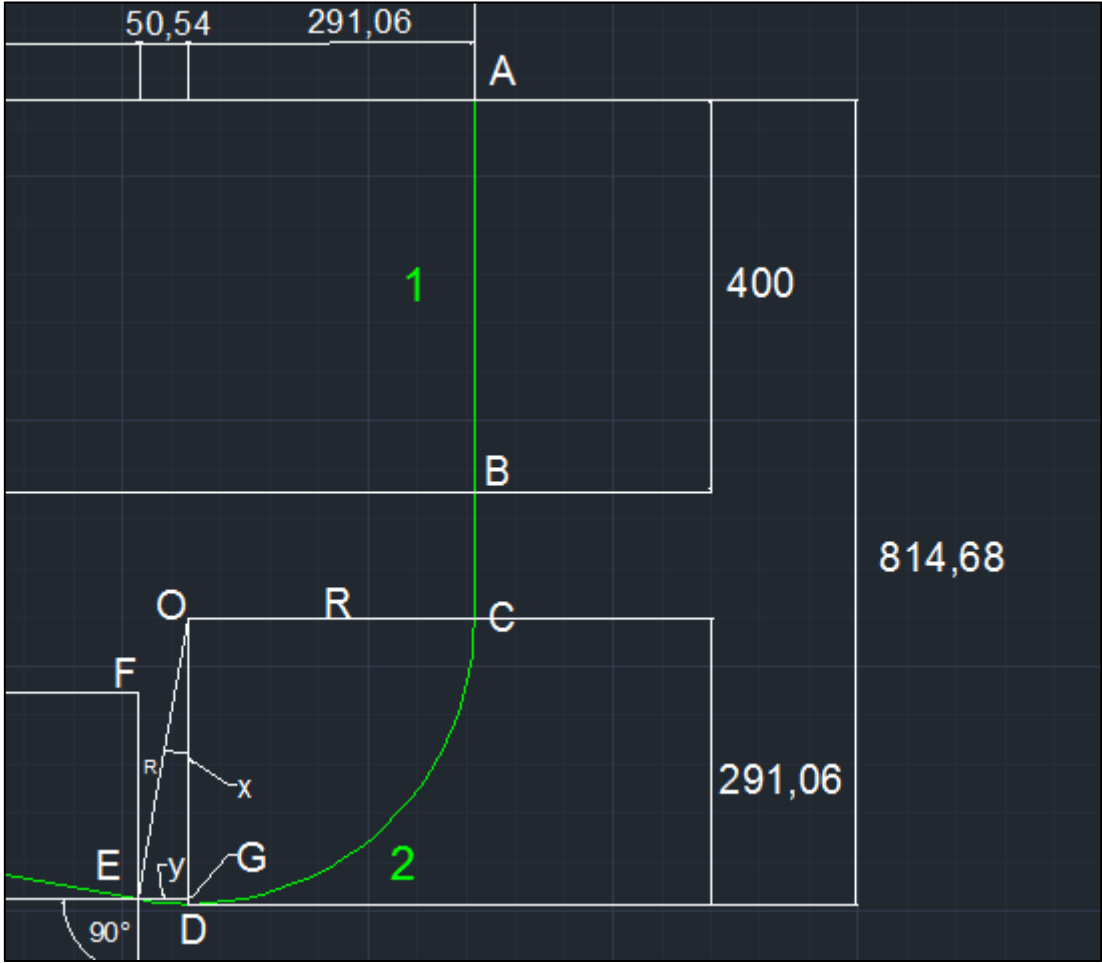

Figure 48 - Relief well vertical section.

Formula for BC:  $BC = TVD - AB - R$

Calculation of BC:  $BC = 814,68 \text{ m} - 400 \text{ m} - 291,06 \text{ m} = 123,62 \text{ m}$

Formula for KOP depth:  $KOP = AB + BC$

Calculation of KOP depth:  $KOP = 400 \text{ m} + 123,62 \text{ m} = 523,62 \text{ m}$

Formula for total MD:  $MD = AB + BC + CE + ET$

Calculation of total MD:  $MD = 400 + 123,62 + 508 + 1176,27 = 2207,89 \text{ m}$

6.2.5.6 Relief well trajectory summary

In the paragraphs above, all necessary calculations regarding relief well trajectory have been performed. All relevant values regarding relief well sections are known, including lengths, depths, inclination and horizontal displacement figures. Also, depth of KOP and total Measured Depth (MD) of the well has been calculated. Detailed relief well planning table is available as Appendix 2 to this

Thesis added in the last chapter. Figure 49 below shows the trajectory summary with all relevant values, lengths and dimensions.

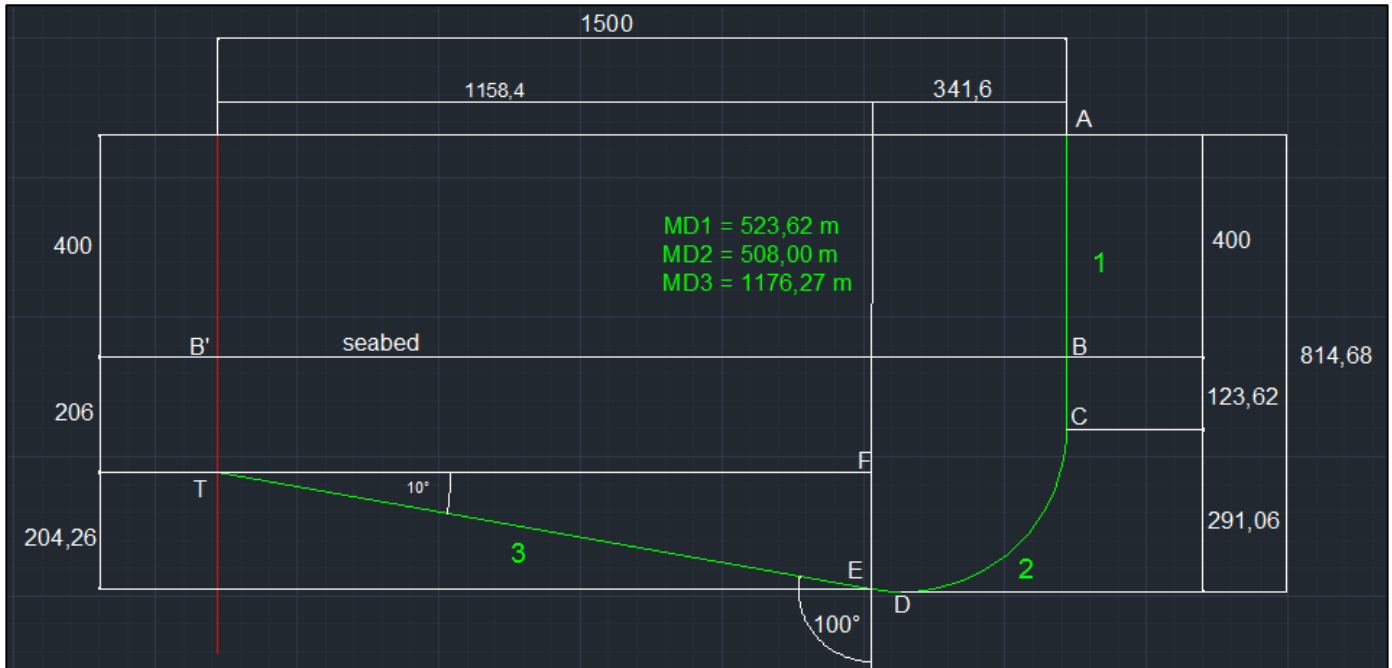

Figure 49 - Relief well trajectory summary.

Relief well trajectory summary is presented in Table 3 below. As it can be seen, proposed trajectory design is well within the boundaries stated at the very beginning of this chapter.

Table 3 - Relief well trajectory summary.

**Horizontal displacement:**

**Depth of intersection:**

**Inclination:**

**DLS value:**

**Azimuth:**

Relief Well.3dd

2 dimensions | 3 dimensions

Type J-1 | Type J-2 | Type J-3 | Type S-1 | Type S-2 | Type S-3 | Type S-4

**2D, Trajectory type: J2, variant: 2**

Input data:		Output data:								
		A[m]	H[m]	L[m]	R[m]	$\alpha$ [°]	$\delta$ [°]	DLS[...]	Azi.[°]	
A[m]	1500,00									
H[m]	606,00	1	0,00	523,62	523,62	0,00	0,00	N/A	N/A	
$\alpha_2$ [°]	100,00	2	341,61	286,64	508,00	291,06	100,00	100,00	6,00	
DLS <sub>2</sub> [°/100ft]	6,00	3	1158,40	-204,26	1176,27	0,00	100,00	0,00	0,00	
Azimuth[°]	360	$\Sigma$	1500,00	606,00	2207,88	N/A	N/A	N/A	N/A	

Vertical section: Direction[°]: 0 | Default

Translate vector: E<sub>0</sub>: 0 | N<sub>0</sub>: -1500 | TVD<sub>0</sub>: 0

Step: 10

Status: READY |  Add to Platform Projection | Well color

Relief well is 1500m to the south of 7324/8-1



### 6.3 Casing design

There are no typical casing design schemes for a relief well of such trajectory. One may assume that well of such trajectory will have somehow specific casing program due to its unconventional character. For example, short, vertical section (1) or long, straight, inclined section (3) of the well strike out. In this Chapter, a hypothetical casing design for such well will be presented based on a casing design proposed by OMV Norge AS for a horizontal well for the same location. Casing load cases are not taken into consideration as there is no sufficient knowledge about the geological/stratigraphical scenario in the area (restricted access, internal OMV Norge AS data).

OMV Norge AS, in one of their presentations about directions of possible development for the Wisting Prospect pointed out, that the production in this area could be carried out with very shallow, horizontal wells with long horizontal sections, which would guarantee successful reservoir drainage and penetrate the reservoir thoroughly. [37] Such well design concept is presented in Figure 50 below.

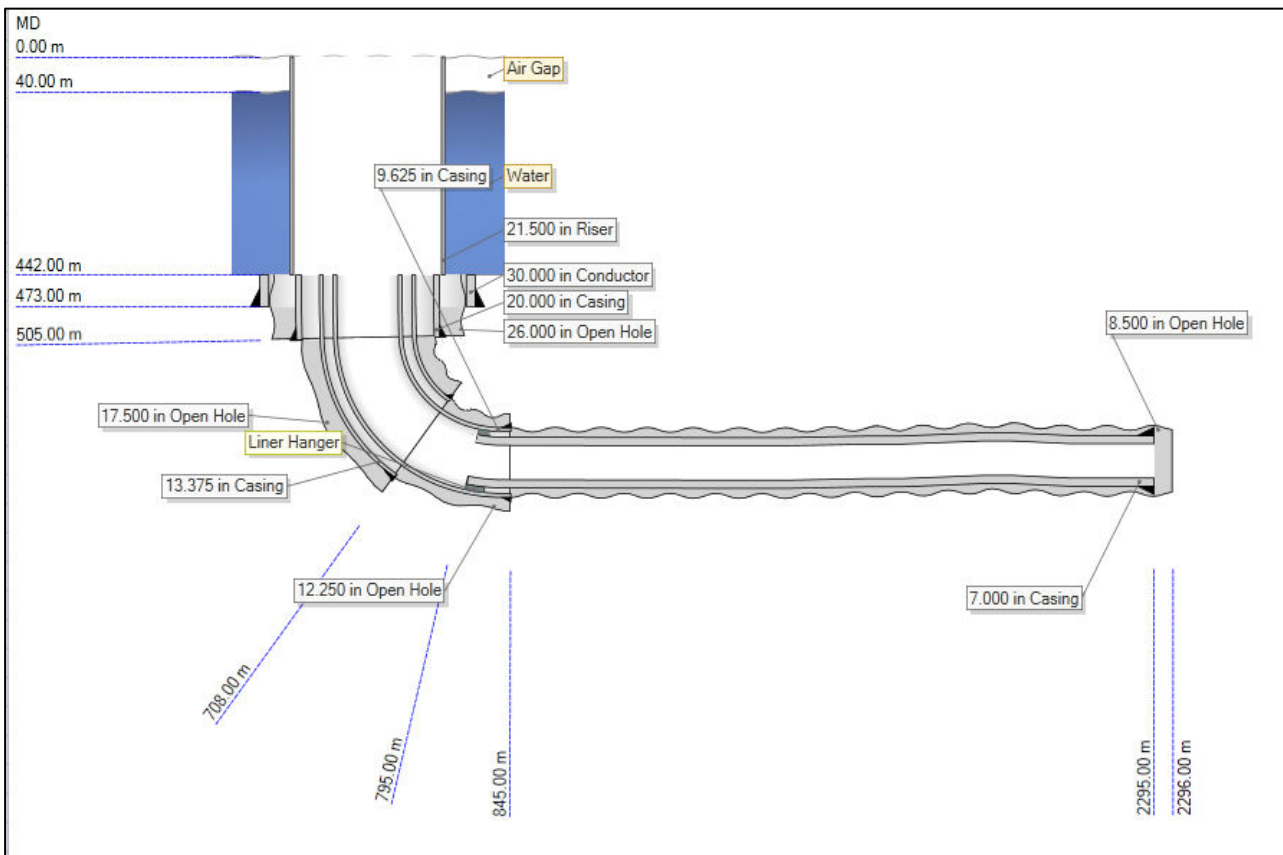

Figure 50 - Horizontal well concept for Wisting Prospect by OMV Norge AS. [37]

Taking into account that the well in Figure 50 has been designed specifically for the shallow reservoir conditions and the very same location, this concept could serve as a base for the development of casing program for the relief well of similar trajectory, size and length.

### 6.3.1 Conductor

As usual, conductor casing will be the first casing string to be run. It serves as a base for the wellbore. Its main purpose will be to provide wellbore stability in shallow, loose formations and to allow for the circulation of drilling fluids. This casing string isolates unconsolidated zones and protects the well from shallow gas. It is cemented to the surface. [38] Usually, the 9-5/8" pilot hole is drilled to check for the presence of shallow gas. Later, the 36" hole is drilled and the 30" conductor is set. The length of this section is usually approximately 50 – 100 meters, however in general it is set at 90 meters from the seabed. [5]

However, in our case the vertical section of the well is very short, as according to the trajectory calculations, the well will start to build inclination just 123 meters below the seabed. Similar situation can be seen in the horizontal well design proposed by OMV Norge AS in Figure 50. Their 30" conductor casing is only 31 meters long (442 m TVD to 473 m TVD), as the build section in horizontal well starts 63 meters below the seabed. [37] In our case, there is no need for such extremely short conductor section. In proposed U-shaped relief well trajectory well starts to build inclination after more than 120 meters have been drilled, therefore it seems reasonable to set the conductor casing to the depth of 60 meters below the seabed (400 m TVD to 460 m TVD).

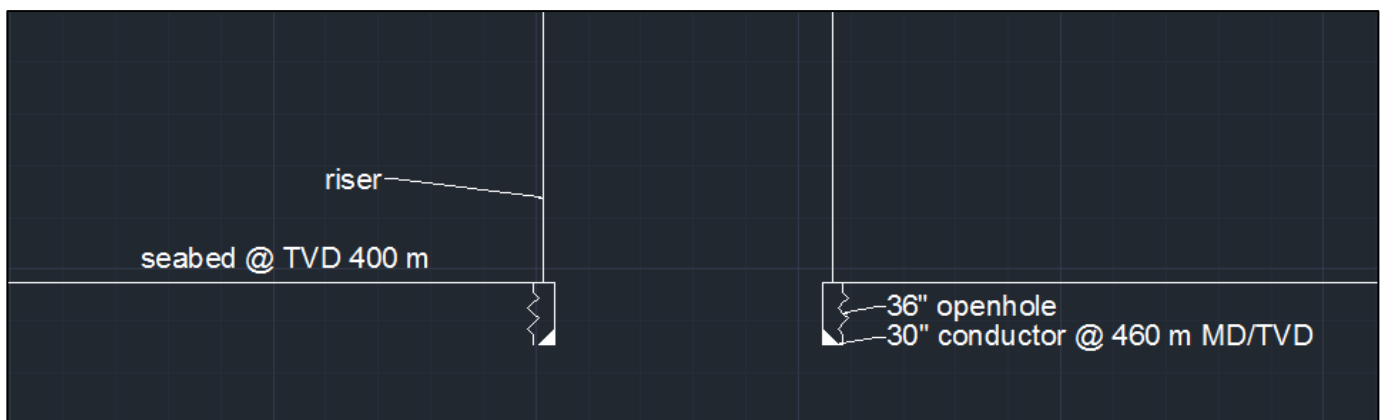

Figure 51 - Relief well casing scheme - conductor.

Placement of 30" conductor casing shoe at 460 m TVD (60 m below seabed) should guarantee wellbore stability. In case of a relief well, this section would be twice as long as it was proposed by OMV Norge AS in the horizontal well plan in similar well conditions. Also, length of 60 meters of this section still would fit into typical length range for that section. The fact that the well is U-shaped allows us to set longer casing strings in the first well sections in comparison to OMV's horizontal well. Well trajectory allows us to start the build section later (well starts building inclination further from the seabed).

### 6.3.2 Surface casing

Surface casing is a second casing string ran into the wellbore. Naturally, it is longer than the conductor casing. It isolates unstable zones and prevents drilling fluid losses (lost circulation incidents). Hypothetically, in deviated wells it can be inclined however, it is a rather rare practice and surface casing is usually set vertically. [38] Similarly to conductor casing, it is also cemented to the surface, or in case of offshore wells, to the seabed. It also protects the well from shallow gas related incidents. Casing shoe of surface casing needs to be placed in stable formation. Setting it in depleted, fractured formations is not acceptable due to well integrity related issues. Usually a 26” hole is drilled and a 20” surface casing string is set in the well. Depending on wellbore construction and trajectory, this section can be very short, or very long. [5] [39]

After careful evaluation of Figure 50 and of casing design for a horizontal well proposed by OMV Norge AS, one can see that due to the very short vertical section of the well the surface casing string is extremely short. Surface casing string stretches on the length of 63 meters (442 m TVD to 505 m TVD). As soon as surface casing shoe is set, well starts to build inclination. It is a common practice in directional wells to set surface casing shoe just above the KOP, so in our case the surface casing could be run to the depth of 520 m TVD (120 m below the seabed), as relief well starts to build inclination 123 m below the seabed.

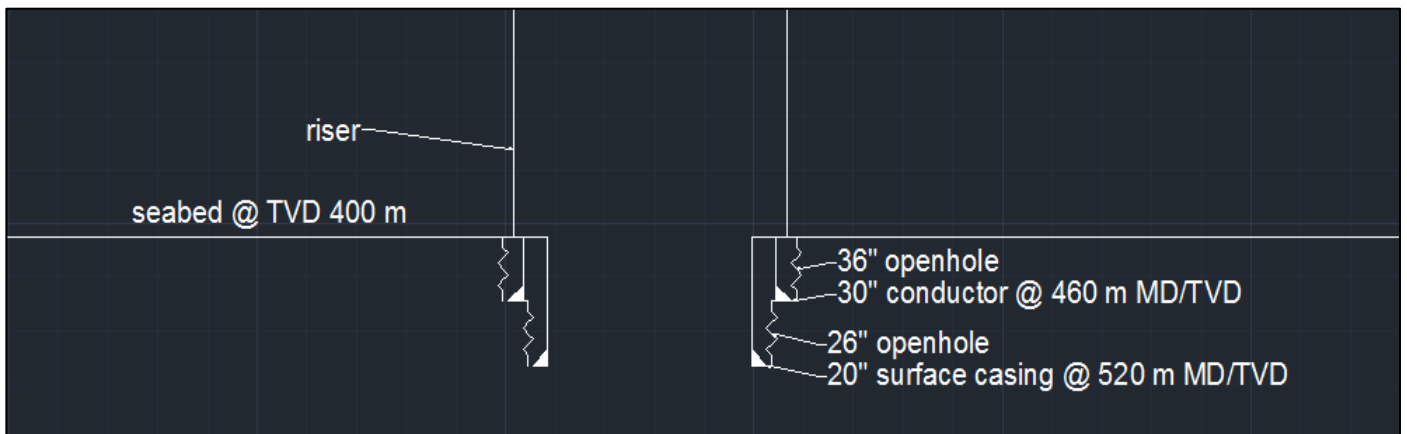

Figure 52 - Relief well casing scheme – surface casing.

120-meter long surface casing string would guarantee better wellbore stability than the 63-meter long section proposed in the casing design for the horizontal well. Relief well would start to build inclination at 523 m TVD (123 meters below seabed). Once again the U-shaped trajectory design approach allows for a deeper placement of surface casing shoe.

### 6.3.3 *Intermediate casing*

Intermediate casing strings are set in the well in order to isolate and case off zones that can be problematic during upcoming drilling operations or production. Examples of such zones include highly depleted formation layers, high-pressure zones, unstable zones, mobile formations such as salts or reactive shales and others. Well can have several intermediate casing strings depending on the well design and geological scenario. [5] [38] [39]

Horizontal well presented in Figure 50 has two intermediate casing strings which is often a case in horizontal wells, as it is beneficial to case off a part of the build section after significant inclination has been built. Second intermediate casing shoe is set just after the build section ends to seal off and isolate the entire build section. Such doing prevents possible hole collapse incidents and stuck pipe incidents related to key-seating (drillstring grinds into formation in inclined section and gets stuck). [5] [39] As it can be seen in Figure 50, first 13-3/8" intermediate casing is set at 708 m MD at the well inclination of approximately 50°. Then the second, 9-5/8" intermediate casing is set just after the build section of the well at 845 m MD at well inclination of 90° (horizontal). Figure 53 below shows the similar casing approach modified for the relief well.

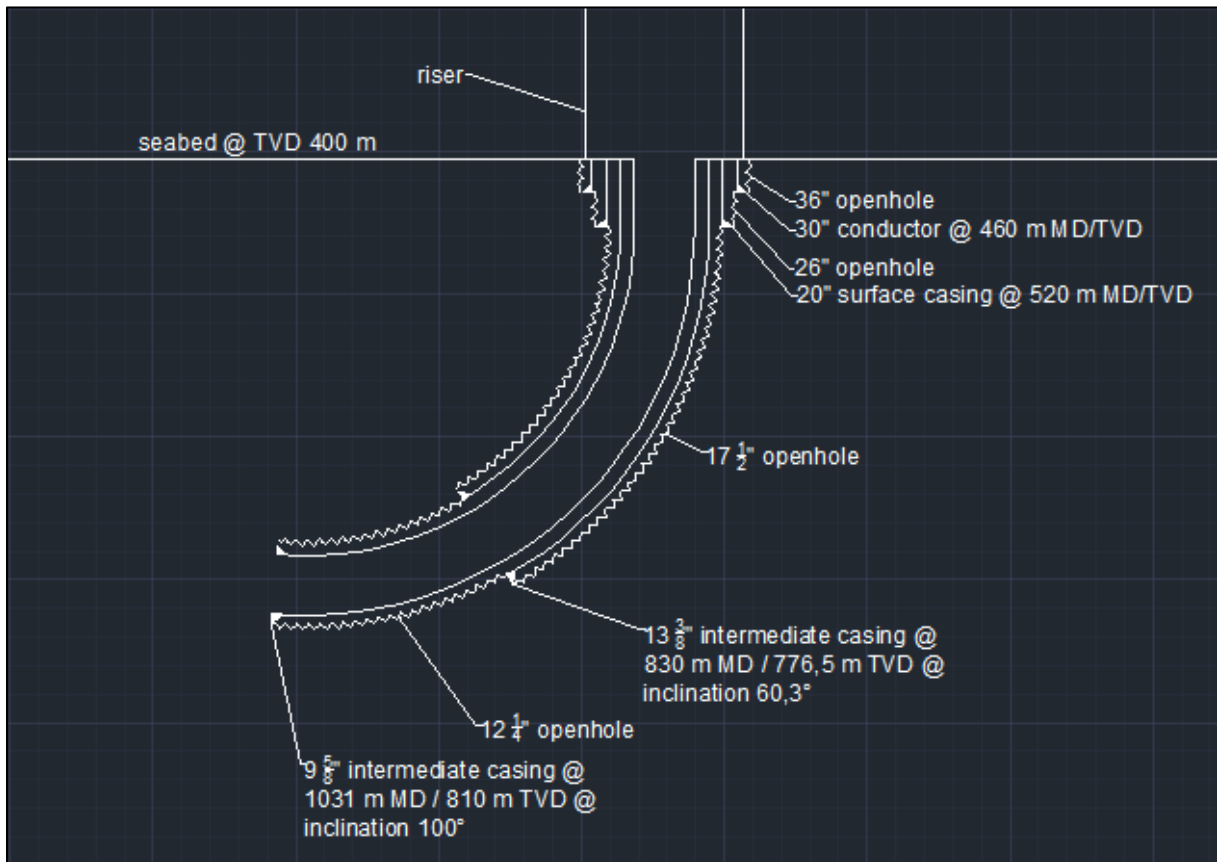

Figure 53 - Relief well casing scheme – intermediate casing.

As the final inclination of the relief well will be 100° (slightly more than horizontal), it would be beneficial to case off the build section with 2 casing strings as well. First 13-3/8" intermediate casing string would be set in a 17-1/2" hole at inclination of 60,3°. Casing shoe would be located at depth of 830 m MD / 776,5 m TVD. Such doing should stabilize first part of the build section, prevent key-seating and allow for effective angle building in the second part of build section. After the second part of build section was drilled the 9-5/8" casing would be set in 12-1/4" hole at depth of 1031 m MD / 810 m TVD. This point would be also the end of build section hence, inclination would be 100°.

6.3.4 Liner

Casing a section of the well with a liner is an alternative to conventional casing. Liner is not run from the wellhead to the setting depth, but instead is set above the casing shoe of previous casing string in a liner hanger. Such practice saves time, lowers costs associated with casing operation and lowers the loads on both wellhead and casing string itself. [5] [39]

In case of OMV's horizontal well presented in Figure 50, last horizontal section of the well is cased off with a liner. 7" liner is set in a 8-1/2" hole from the end of the build section up to the end of horizontal section on the distance of 1450 meters. Such doing lowers the loads on the casing string, as it is not set along the highly deviated build section. Similar approach could be utilized in the casing design of the relief well as presented in Figure 54.

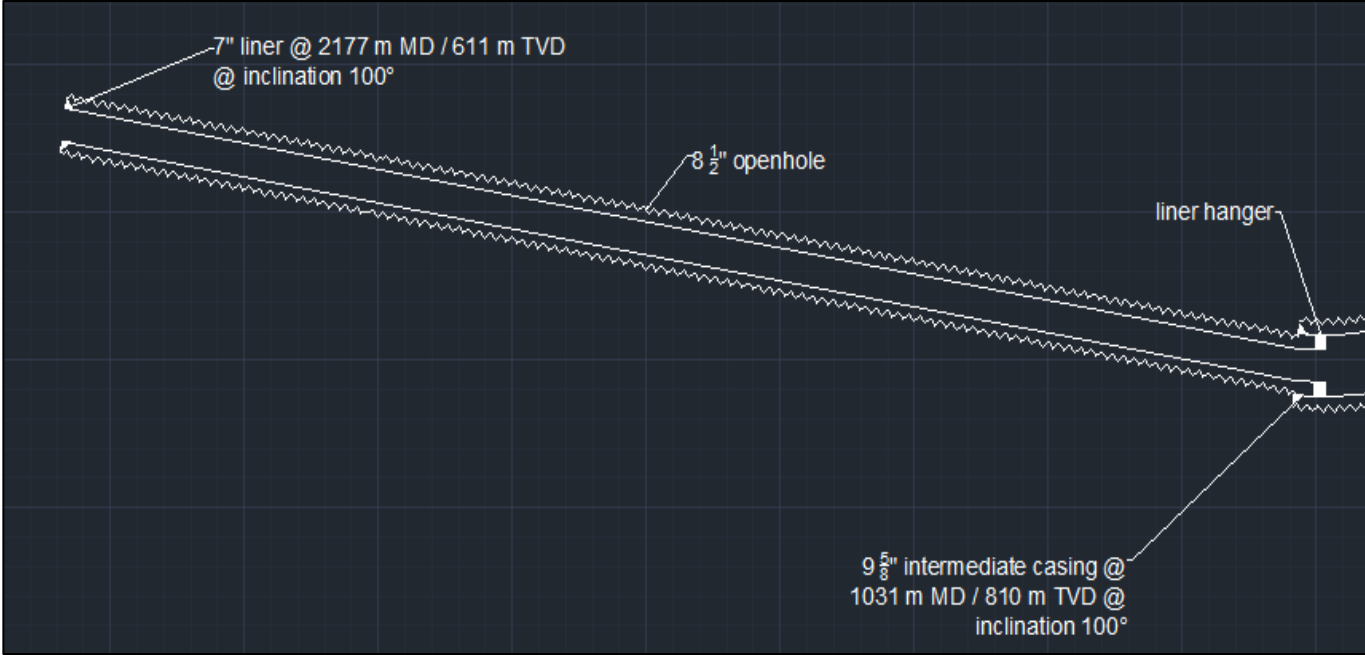

Figure 54 - Relief well casing scheme - liner.

7” liner would be set in a 8-1/2” hole. Length of that section would be 1146 m (1196 meters with overlap) and the last casing shoe would be set at 2177 m MD / 611 m TVD just before the planned intersection point. Liner hanger would be set approximately 50 meters above the casing shoe of 9-5/8” intermediate casing. [40] Well inclination through the last section of relief well would be at constant 100°. Last casing shoe of the relief well would be placed 31 m before the intersection point with the ‘blowing’ well. Usually this last, short section of relief well up to the intersection point is drilled as open hole. [13] Such relief well design would allow for intersection with ‘blowing well’ with, for example, 6” open hole section as presented in Figure 55 and Figure 56 below.

**Table 4 - Relief well casing plan.**

Casing String	Hole diameter	Casing OD	Section start MD	Section end MD
Conductor	36”	30”	400 m	460 m
Surface casing	26”	20”	460 m	520 m
Intermediate 1	17-1/2”	13-3/8”	520 m	830 m
Intermediate 2	12-1/4”	9-5/8”	830 m	1031 m
Liner	8-1/2”	7”	1031 m	2177 m
Open hole	6”	-	2177 m	2208 m

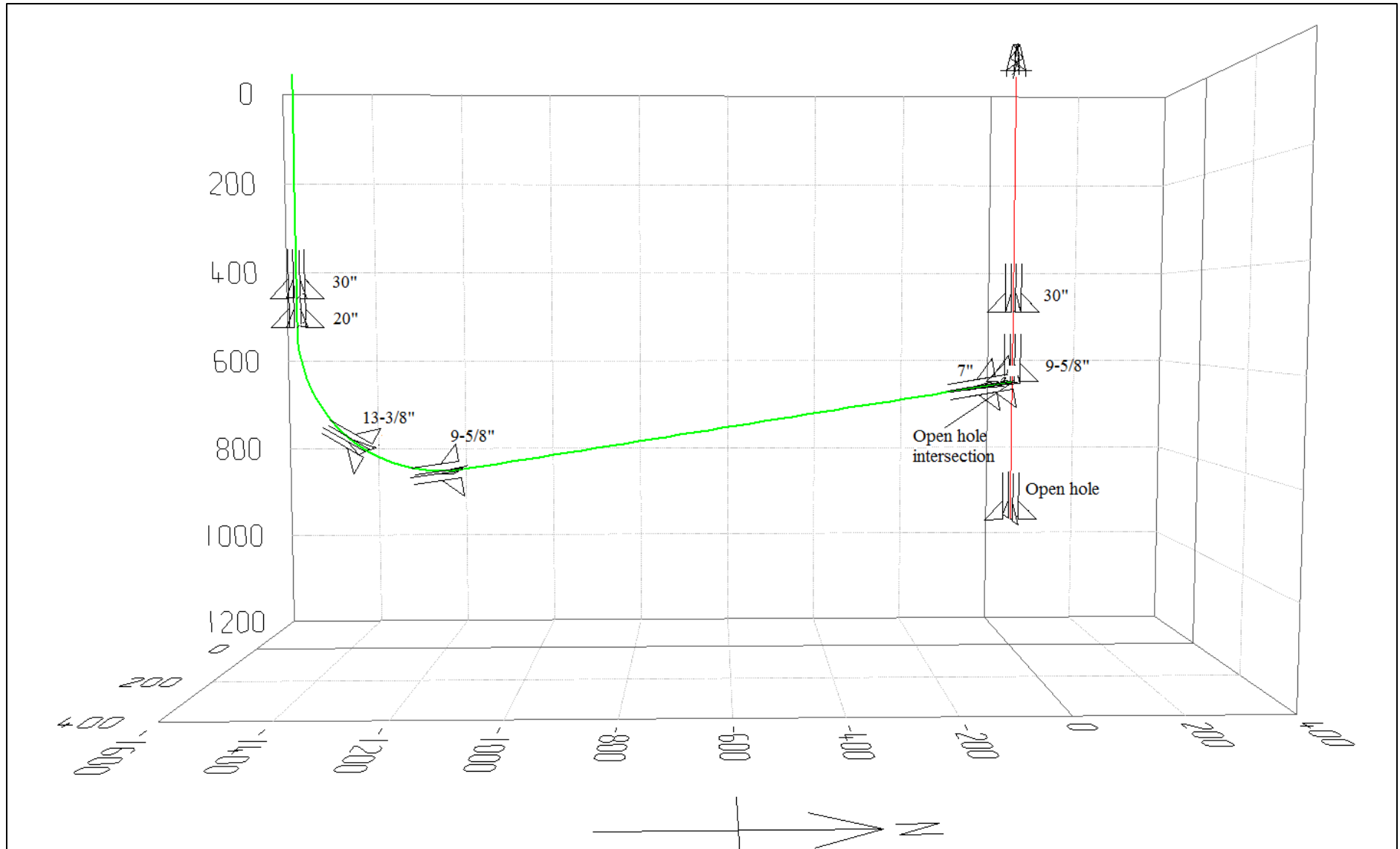

Figure 55 - Relief well and 7324/8-1 well casing scheme.

\*for better readability Figure 56 is not drawn in scale

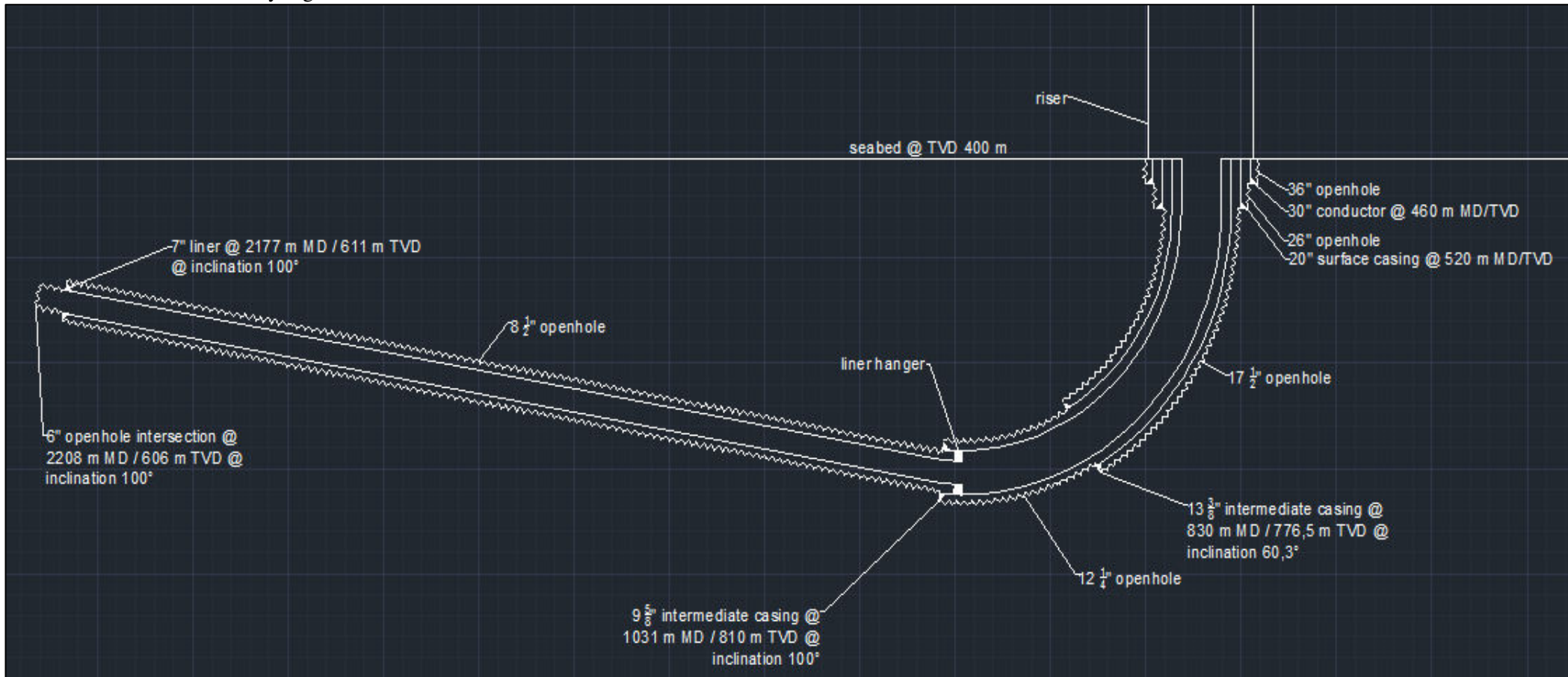

Figure 56 - Relief well casing scheme - summary.



## 7 Chapter VII – Discussion – Possible Challenges

Always while considering a novel idea or solution, such as the relief well trajectory proposed in this Thesis, one must raise several questions regarding the viability and feasibility of the concept. The more it deviates from a standard, conventional approach, the more questions need to be asked and the more thorough the analysis has to be. While considering this U-shaped relief well approach and designing the well trajectory, numerous possible challenges of such design have been noticed. Some of them have already been discussed in the past, but some of them are directly associated with such relief well concept and shallow reservoir scenario and have not been addressed yet. Nevertheless, it is vital to point out possible challenges that can be associated with this approach and technical obstacles that need to be overcome. In this chapter the overview of possible operational and designing challenges will be given.

### 7.1 Shallow conductor and surface casing placement

Exploring and producing from shallow reservoirs as those located on Barents Sea, but also in other parts of the world, will force companies to implement some unconventional well design scenarios. One of perks of drilling in such areas is that when a directional well is to be drilled, regardless whether it would be a horizontal producer like the one presented in Figure 50, or a relief well like the one proposed in this Thesis, it will have a very short vertical section. The reason for that is so the build section of the well, required to build the angle, can be started as soon and as shallow, as it is possible.

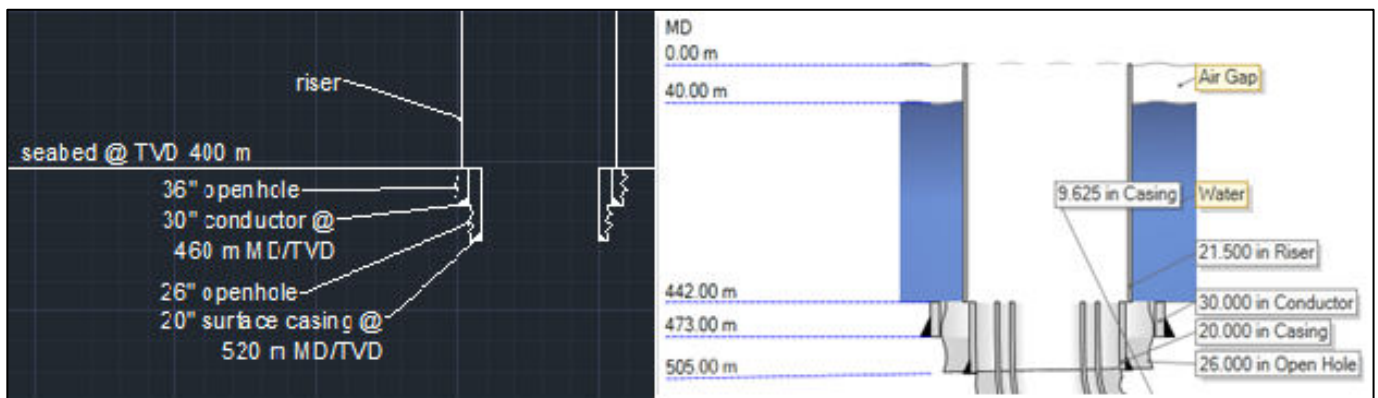

Figure 57 - Shallow conductor and surface casing placement.

Examples of such casing design are given in Figure 57 above. In such cases, questions about wellbore's top section stability may raise. Appropriate length of conductor and surface casing is required to successfully stabilize top section of the well, prevent washouts and prevent incidents related to shallow gas accumulations. One may argue whether 31 or 60 meters of conductor casing and 63 or 120 meters of surface casing, as presented in Figure 57 is enough to address all tophole issues in such wells.

Apparently, this issue has been already considered. Due to the fact, that usually little is known about shallow formation strength, and pore pressure in them is very low, little attention has been given to this issue. Often small pilot holes are being drilled, before the section of a nominal diameter is drilled, so

usually all relevant information about possible dangers and difficulties are available prior to setting of conductor or surface casing string. Therefore, often the casing shoe setting depth in case of those two first casing strings is arbitrary. [41] Also, if the shallow formation layers are solid and of good quality, as it is the case in Barents Sea area, casing setting depth can be lower. In reference to the relief well casing design, it is said that approximately 180 ft (55 meters) is enough to prevent washouts and guarantee wellbore stability in top section, so 60 meters as it is the case in proposed relief well design could be considered as enough. [42]

## 7.2 High dogleg severity (DLS)

One may argue, that the assumed dogleg severity in the build section of proposed relief well is higher than in case of typical wells and that would be true. In case of conventional directional wells, DLS value rarely exceeds  $5^\circ / 30$  meters and even that is considered quite high, at least in Norway. However, when horizontal wells are included in the discussion, especially from the global point of view, it occurs that DLS of approximately  $6^\circ / 30$  meters is a perfectly acceptable value. In case of proposed relief well, the DLS value of build section is exactly  $5,9055^\circ / 30$  meters. When this value is confronted with horizontal well classification presented in Figure 38 it turns out that it is a long radius type of the well, which is the least aggressive type in this classification.

When the DLS value of proposed relief well is confronted with the DLS value of horizontal well presented in Figure 50, which has been designed for the location considered in this Thesis, following conclusions can be drawn:

- Horizontal well KOP depth – 505 m MD
- Horizontal well EOB depth – 845 m MD
- $\Delta MD = 845 \text{ m} - 505 \text{ m} = 340 \text{ m}$
- Dogleg angle –  $90^\circ$
- $DLS = \frac{90^\circ}{340 \text{ m}} = 7,94^\circ / 30 \text{ m}$

When those two DLS values are compared, it is clearly visible that the DLS in the build section of relief well is significantly smaller than the DLS value throughout the build section of the proposed horizontal well. One must also notice the availability of directional drilling tools, which allow to drill with DLS of even up to  $15^\circ / 30$  meters. [43] However, it needs to be pointed out, that the DLS value of approximately  $6^\circ / 30$  meters will create certain limitations when it comes to well design, for example in casing program, or will cause faster and more severe casing wear. [44]

### 7.3 Cuttings transport

Cuttings transport issue in deviated wells has been on the agenda of researchers for years. Numerous theoretical and practical studies have been performed and this issue seems to be resolved in lightly inclined wells. Then again, as the inclination of wells grew the issue became more and more complex, up to the point, where the topic of cuttings transport in wells that are nearly horizontal or horizontal arose. Naturally, the process of cuttings transport is strongly dependent on numerous factors such as: drilling mud flowrate, rate of penetration (ROP), mud properties, cutting characteristics and others, but some of the crucial factors that will affect the hole cleaning process are wellbore geometry and its dimensions. This includes wellbore diameters, pipe sizes but primarily, inclination angle and section lengths. [45]

Proposed U-shaped relief well trajectory will generate numerous challenges similar not only to inclined or nearly horizontal wells (build section or long, straight, nearly horizontal section), but also associated with the specific shape of the well itself. The fact that the deepest point of the well (point with highest TVD) is located somewhere in the middle of well path will strongly affect the process of cuttings transport.

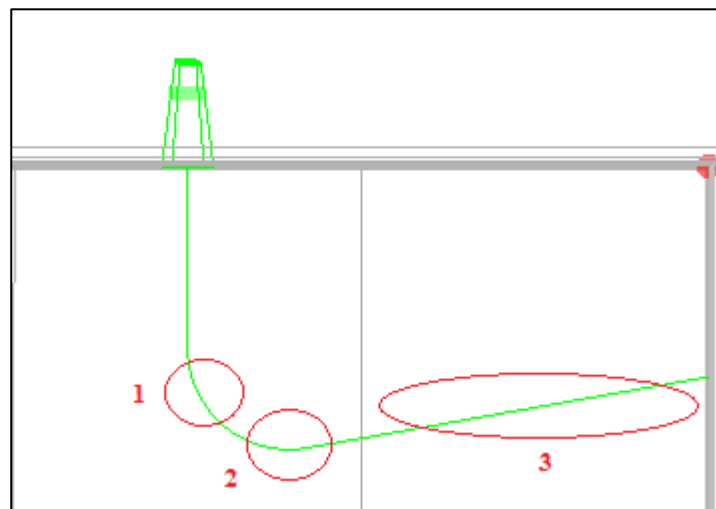

Figure 58 - Potential problematic zones for cuttings transport.

Figure 58 presented above shows the relief well wellpath with 3 zones marked in red along it, where the cuttings transport problems and challenges are likely to rise. Characteristics of possible problems is based on [39] and can be described as:

- Zone 1 – lightly inclined and inclined section of the well, such as build section, is crucial to successful drilling progress. This section however, may suffer from so called cuttings landslides, especially if the concentration of cuttings is too high or the drilling mud circulation is stopped. Cuttings would then slide down the well instead of being carried to the surface in the drilling mud. Drilling mud property known as thixotropy would allow for the cuttings suspension during the circulation breaks. [39] [46]

- Zone 2 – the deepest point of the well at the end of build section will suffer from numerous challenges. This part of the wellbore, due to its significant inclination (80° – 100° - nearly horizontal) may cause cuttings to accumulate at the bottom of the hole in its deepest point. Cuttings from both sides of the well may slide back into this section and cause numerous problems such as stuck pipe incidents. Well in this point may become clogged with cuttings and formation debris. [39]
- Zone 3 – long, straight, lightly inclined section of the well may cause challenges similar to those in horizontal wells. Cuttings may accumulate at the bottom wall of the well forming cutting bed or cutting dunes. Those cutting particles have to be transported out of the hole. In zone 2 and zone 3 high drilling mud flowrate and turbulent flow regime is strongly advised to prevent incidents related to poor hole cleaning. [39]

Generally speaking, the U-shaped relief well trajectory can be considered as operationally challenging, especially when it comes to the issue of cuttings transport. Such shape not only creates typical challenges associated with inclined or horizontal wells, but also suffers from additional critical obstacle, which is the fact that the deepest point of the well is located somewhere in the middle of the well path, rather than at the end of it.

#### **7.4 Lower Weight on Bit (WOB), increased friction**

One of main goals while performing drilling operations is to drill the well as fast as possible, without any unwanted incidents in a safe and efficient manner. There are numerous factors that affect the speed and therefore, the efficiency of drilling operations such as [47]:

- Type of drill bit,
- Rotary speed,
- Hole cleaning,
- Mud properties,
- Formation hardness,
- Weight on Bit and Well friction.

Taking into account the unconventional, U-shaped character of proposed relief well trajectory, certain challenges in hole cleaning may occur, as it was pointed out in the previous paragraph 7.3. However, what also needs to be considered, is the fact that the shape of build section will strongly affect the drilling performance. The more deviated and inclined the hole is from vertical, the bigger is the well friction generated between the drillstring and the walls of the hole.

While drilling directionally or horizontally, drillstring grinds on the surface of the formation or pipes if the hole is already cased. Additional well friction is generated that way, which affects the Weight on Bit (WOB) conducting to the bottom of the hole. The bigger is the well friction generated along the well path, the lower the WOB is, which eventually may result in a serious decrease in Rate of Penetration (ROP) and the efficiency of drilling operation may drop dramatically. [48] What is more, it may even turn out that certain well trajectories are impossible to drill with a conventional approach. Drilling of such relief well, as the one proposed in this Thesis, would require careful evaluation of the WOB conducting process along the drillstring. It may occur, that drilling of such well would require modified Bottom Hole Assembly (BHA) or changes in the entire drillstring composition in order to provide sufficient WOB at the bottom of the hole and drill successfully and efficiently.

### **7.5 Drilling equipment, Directional control, Geosteering**

Drilling of a relief well is a complex operation performed usually in a stressful environment where time is an issue. As the idea is to drill a well that will intersect with the blowing well many meters down into the formation, the accuracy will be crucial to eventual success of such operation. Process such as relief well drilling will then require the highest possible accuracy and control. Entire operation should be also performed in a timely manner and with the lowest possible risk.

As most of relief wells are directional wells, the choice of directional drilling equipment will have a significant impact on the entire operation. Available directional drilling tools can be divided into either motors or Rotary Steerable Systems (RSS). [50] In emergency situations, such as a relief well drilling, there is a strong incentive to use Rotary Steerable System. [51] There are several reasons to support such statement:

- Rotary Steerable Systems have fully integrated Measurement While Drilling and Logging While Drilling systems (MWD & LWD) capable of data transfer and communication with the surface in real time. This allows for a better directional control and proactive decision making based on the results received from downhole. Entire geosteering process becomes much simpler. [50]
- RSS allows to rotate the drillstring while changing direction, on the contrary to slide drilling, while the motor is being used. The drillstring constantly rotates, while the direction is being changed by pads being deployed from RSS and pushing against the formation – ‘push the bit’ approach. [50]
- Rotary Steerable Systems offer higher Rate of Penetration than motors. This is crucially important in relief well drilling, as there is a strong incentive to drill the well as fast as possible. [50]

- Drilling with RSS allows for smoother wellbore and less well friction, since there is no borehole spiraling as it is the case while drilling with motor. [50]
- Since RSS allows for drillstring rotation while changing direction, this will be greatly beneficial when it comes to the matter of cuttings transport along the well, as rotation makes cuttings transport much easier. [50]

Generally speaking, RSS is a standard technical solution in case of relief well drilling. As most of the points made above are relevant to relief well technology in general, the last two, regarding well friction and cuttings transport, will be vitally important for the concept of U-shaped relief well, as the one proposed in this Thesis. Choice of directional drilling tool is therefore a crucial issue.

### **7.6 Tracking & localization**

Prior to blowout situation, only traditional surveys of the considered area are taken. However, those surveys suffer from positional uncertainty due to imperfections of surveying methods. [52] As the aim is to drill a relief well and intersect with the blowing well directly, accuracy of the entire process will be incredibly important, so every possible way to improve it will be an advantage. Another matter that needs to be pointed out, is that in the U-shaped relief well trajectory approach, the process of locating, tracking and intersection will vary from the approach in a typical S-shaped relief well. As it was pointed out in the theoretical introduction, in the S-shaped approach the relief well firstly approaches the blowing well trajectory, localizes it with magnetostatic or electromagnetic tools and then orients for intersection. Intersection happens in the second approach. U-shaped relief well trajectory will suffer from the lack of the first approach to the blowing well, as the character of homing-in process will be different in that case. Generally speaking, there is an incentive to know the positions of both wells in reference to each other as accurately and as early as possible. Certain solutions could be implemented to increase the detectability range of the blowing well and the accuracy of positioning of both wells in reference to each other:

- Casing premagnetization – a novel solution that can be used to increase the detectability of the blowing well’s casing. According to [53] this service can be specifically dedicated to shallow relief well intersection scenarios. This solution needs to be planned for in advance before the well is cased. Casing is magnetized during the exposition to magnetic field created by electrified coil. Artificial magnetic field is created and the detection radius can be increased from several meters to even more than 20 meters in case of a casing joint. This distance can be even larger while ranging for casing’s middle part. [53] Casing’s premagnetization will make it far easier to detect it from the relief well using magnetic sensors. This way the risk associated with localization, tracking and homing-in operation can be lowered. Relief well can be drilled faster and direct intersection can be obtained more effectively.

- Surface Seismic While Drilling (SSWD) [54] – this is a new method that should allow for identification of wellbore’s position in reference to each other. A source positioned on the surface emits seismic waves that penetrate the formation, reflect and are collected by receivers set at the seabed. Such seismic survey should make it possible to locate well paths of both wells, blowing well and relief well. This method would allow for real-time well position monitoring, more precise spatial orientation and effective intersection. Small depth of both wells, such as in shallow reservoir scenario, should allow for more accurate wells positioning. SSWD could potentially be used as a supporting method along with magnetic surveys or conventional MWD. Potentially, if the SSWD technology is developed and several criteria are fulfilled, it could serve as a standalone method to guarantee direct intersection between the relief well and blowing well. It should allow continuous accurate wellbore positioning and real-time well path illustration on seismic cross-section or seismic cube. [54]

Due to the lack of first approach to the blowing well in case of U-shaped relief well trajectory, such solutions as mentioned above need to be implemented to assure accurate positioning of both wells in reference to each other. MWD tools would give certain information about relief well position while drilling. SSWD technology could provide a real-time information about position of both wells in reference to each other without interference with drilling. Casing premagnetization would allow for early blowing well’s casing detection and simplify the intersection procedure dramatically.

### **7.7 Homing-in & intersection**

As it was pointed out in paragraph 7.6 above, the character of homing-in in U-shaped relief well concept would differ significantly from the same procedure in a typical S-shaped relief well. Due to the lack of first approach to the blowing well above the intersection point, different scenario needs to be implemented.

Industrial practice showed that this different approach could be to drill past to the side of the blowing well and then localize the wells in reference to each other. This process is called bypassing. [55] As localizing tools such as magnetic sensors or LWD equipment do not have the ability to survey the formation in front of the drillstring, they need to be located on the side of the blowing well and its casing to allow for localization. [50] Presence of casing is then important in the homing-in process to allow for tracking and positioning with magnetic tools and that is why the intersection point has to take place above the last casing shoe. Thanks to that approach, localization process should be far more accurate.

The bypass approach has been successfully utilized in the industrial practice on the Montara blowout in Australia, in 2009. The scenario there was that the nearly vertical relief well was drilled and it had to intersect with the horizontal well in the horizontal section. After the last casing string of the relief well

was in place, the drilling continued. The well drilled past the blowing well to its side and localized it with magnetic tools. The distance was measured as well. Then the drillstring was pulled back, the hole plugged and second sidetrack was drilled near the blowing well to localize it and measure the distance once again. The process was repeated until the exact location of blowing well was known and the direct intersection with the blowing well was possible. [55] Figure 59 below shows the process of bypassing and localizing of the blowing well. Relief well and sidetracks are marked in green, blowing well is marked in red.

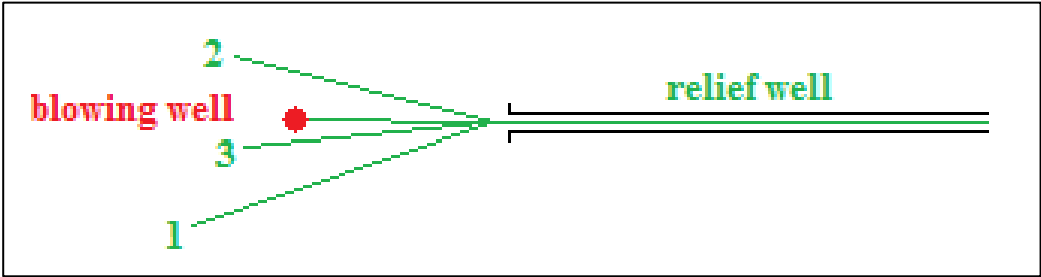

Figure 59 - Bypass homing-in process scheme.

Approach similar to bypassing on Montara blowout could be possibly utilized in the U-shaped relief well trajectory, although the scenario would be somehow inverted – vertical blowing well and relief well intersecting with it from the side, nearly horizontally.

**8 Chapter VIII – Summary, Conclusion**

Drilling of a relief well (or several relief wells) and performing a dynamic kill procedure is a last resort method when it comes to blowout contingency. In case of a blowing well scenario, there is a strong incentive to regain control of the well as fast as possible to mitigate the danger, prevent financial losses and avoid environmental damages. Relief well drilling is often performed in stressful environment and under time pressure. Therefore, such operation needs to be carefully evaluated and planned in advance. Every well that is drilled, requires a well control program, where the complete design of relief well operation can be found.

Generally, relief wells for deep reservoirs have been drilled numerous times around the world and the concept is quite well developed. Usually it is the S-shaped relief well that slowly approaches the blowing well, localizes it during first attempt and then tracks and orients for intersection. Intersection happens in the second attempt and dynamic kill procedure begins.

However, this approach cannot be utilized in a shallow reservoir scenario, as it was pointed out in Chapter III. Such shallow reservoir scenario requires a different approach, as it is impossible to design the S-shaped relief well of such shallow depth. This Thesis proposed a different approach of a U-shaped relief well, which seems to be the only possible solution for a relief well trajectory for a shallow reservoir. As a typical shallow reservoir case study for this Thesis, Wisting Prospect on Barents Sea Production License 537 has been chosen. The relief well has been designed for a wildcat well 7324/8-1.



Firstly, two possible surface locations for potential relief wells have been chosen according to six criteria. Those criteria would be the same for a shallow reservoir and conventional, deep reservoir scenario, as they only determinate the surface location of the rig. The drivers for surface location choice are the same in both situations. Apparently, the horizontal displacement from the blowing well to the relief well has been defined as 1500 m, which is well within the boundaries of usual practice. Such horizontal displacement value was set as a design boundary in a trajectory design. The relief well trajectory was then designed for the one of two chosen locations, 1500 m to the south of the well 7324/8-1.

The U-shaped relief well trajectory has been calculated in detail and such design has been visualized in both 3Ddrill and Landmark COMPASS software. Values of design parameters have been chosen according to conventional relief well practice (horizontal displacement, intersection point depth, DLS), inclination value has been set as 100°, as close to horizontal as possible and according to industrial recommendations. [30] Summary of U-shaped relief well trajectory:

- Horizontal displacement – 1500 meters to the south
- Azimuth of relief well – 360°
- Inclination in hold section (3) – 100°
- Depth of intersection point – 606 m TVD (206 m below the seabed)
- DLS – approximately 6°/100 ft = 5,9055°/30 meters
- 3 well sections – vertical (523,62 m MD), build (508 m MD), inclined (1176,27 m MD)

The casing design for a relief well has been based on the already existing concept of a horizontal well designed for the very same location. Due to the restricted access to geological data, feasibility of the design could not be evaluated, which is one of the recommendations for future work. Later, a detailed discussion of concept's applicability has been performed. Numerous possible challenges of this concept have been pointed out and addressed.

Summary and conclusions regarding such relief well approach and design:

- Shallow reservoir scenario requires different relief well design and trajectory,
- U-shaped relief well could be a potential solution for such scenario,
- While designing proposed relief well as many values as possible have been kept within the conventional relief well design practice (horizontal displacement, moderately high DLS, intersection point placement) or within already existing concepts and solutions from the industry (inclination close to horizontal, casing design),
- U-shaped relief well trajectory would cause numerous challenges on different phases of development (Chapter VII), some of those challenges have been already addressed, some are in phase of development and potential solutions have been proposed and discussed,

- Possible challenges include matters connected with well's geometry – slightly higher DLS, cuttings transport related issues, lower WOB or with the process of drilling and intersection – high surveying accuracy requirement during tracking or blowing well's bypassing process,
- Further research is needed to prove the feasibility of such concept (Chapter IX).

## 9 *Chapter IX – Future Work*

Shallow reservoir scenario is a quite unconventional situation when it comes to oil and gas exploration and production. However, such scenarios, as the one on the PL537 on Barents Sea require different approaches when it comes to various phases of exploration and development. One of the biggest differences between conventional reservoir and shallow reservoir is the relief well design in case of potential lost well control situation. Relief well design approach proposed in this Thesis is only a concept and numerous further studies need to be performed in order to prove the feasibility of such solution. However, due to its general character, it gives a lot of freedom when it comes to future work and research. Possible future research directions for this concept include:

- Torque & drag calculations – such analysis could be performed to calculate parameters relevant to drilling of such well. Calculation of well friction could be performed, eventual design of drillstring or Bottom Hole Assembly could be given and justified. The outcome of torque & drag analysis could also possibly affect the relief well trajectory proposed in this Thesis.
- Casing program design evaluation – given, that the geological and lithological scenario of a shallow reservoir prospect is known and detailed information regarding type of formation, pore pressure and fracture pressure gradient are available, a detailed study on casing design could be performed. Potential stress and tension in casing could be calculated. Such study should also include the calculation of required casing strength for various casing strings, potential maximum setting depth for each string and choice of a required type of steel for each section. It could also be performed for the PL537 scenario when the geological data become accessible to all parties. One could also prove the feasibility of casing design proposed in this Thesis not only based on already existing concepts for similar wells, but on actual calculations.
- Dynamic kill modelling – assuming that relevant information regarding pressure of blowing formation, well dimensions, trajectories and intersection point are either available or assumed, the dynamic kill procedure modelling of shallow reservoir scenario could be performed. The outcome of such study would include hydraulic parameters of dynamic kill procedure for a blowout from shallow reservoir. Relevant pressures could be calculated, required pumping power, flowrates, number of pump modules. OLGAs Flow Simulator could serve as a useful tool for such study. Similar studies have already been done, but never for a shallow reservoir blowout and for such relief well trajectory.

## 10 Chapter X – References

- [1] British Petroleum, *Deepwater Horizon Accident Investigation Report*, 8<sup>th</sup> September 2010
- [2] Picture of Deepwater Horizon Platform sinking, available at: <http://scriptshadow.net/wp-content/uploads/2014/08/rUNFYnD.jpg>, downloaded: 29<sup>th</sup> January 2016
- [3] Picture of surface blowout on a drilling rig, available at: [http://www.alaska-in-pictures.com/data/media/17/oil-rig-blow-out\\_3232.jpg](http://www.alaska-in-pictures.com/data/media/17/oil-rig-blow-out_3232.jpg), accessed: 8<sup>th</sup> February 2016
- [4] Westergaard, R., *All About Blowout*, Norwegian Oil Review, 1987, ISBN 82-991533-0-1
- [5] Fjelde, K.K., *Life Cycle of the Well – Introduction Lecture 1*, University of Stavanger, 2015
- [6] Wright, J.W., Flak, L., *Relief wells: Advancements in technology and application engineering make the relief well a more practical blowout control option*, available at: <http://www.jwco.com/technical-literature/p11.htm>, accessed: 29<sup>th</sup> January 2016
- [7] Picture of Relief Well in Conroe, Texas, 1933, available at: [https://drilleng-group4-directionaldrilling-1.wikispaces.com/file/view/conroe\\_blowout.png/228510966/conroe\\_blowout.png](https://drilleng-group4-directionaldrilling-1.wikispaces.com/file/view/conroe_blowout.png/228510966/conroe_blowout.png), downloaded: 29<sup>th</sup> January 2016
- [8] API RP 59, *Recommended Practice for Well Control Operations*, Second Edition, May 2006
- [9] Relief well scheme, available at: <http://geology.com/articles/horizontal-drilling/horizontal-drilling-relief-well.gif>, accessed: 31<sup>st</sup> January 2016
- [10] Electromagnetic casing detection scheme, available at: <http://static6.businessinsider.com/image/4c46ed8b7f8b9aaf35b80300/what-you-need-to-know-about-this-weekends-risky-final-kill-relief-well.jpg>, accessed: 31<sup>st</sup> January 2016
- [11] Relief well and blowing well intersection scheme, available at: <https://www.govloop.com/blogs/10001-11000/10960-reliefwellmagnet.gif>, accessed: 31<sup>st</sup> January 2016
- [12] Typical relief well trajectory and pumping scheme, available at: [http://www.drillingcontractor.org/dcpi/2009/july-aug/relief/Figure1\\_fmt.jpeg](http://www.drillingcontractor.org/dcpi/2009/july-aug/relief/Figure1_fmt.jpeg), accessed: 31<sup>st</sup> January 2016
- [13] Goobie, R.B., *A Guide to Relief Well Trajectory Design using Multidisciplinary Collaborative Well Planning Technology*, British Petroleum, 2015, available at: [http://www.iscwsa.net/files/6914/2716/0877/03\\_-\\_A\\_Guide\\_To\\_Relief\\_Well\\_Trajectory\\_Design\\_Roger\\_Goobie.pdf](http://www.iscwsa.net/files/6914/2716/0877/03_-_A_Guide_To_Relief_Well_Trajectory_Design_Roger_Goobie.pdf)
- [14] Landmark Halliburton, *New Collaborative Well Planning Tools, Optimize Relief Well Designs in Gulf of Mexico*, 2014, available at: <https://www.landmark.solutions/Portals/0/LMSDocs/CaseStudies/Relief-Well-Planning-Case-study.pdf>, accessed: 3<sup>rd</sup> February 2016
- [15] Anders Kallhovd, *Evaluation of a dual relief well operation*, NTNU, 2013
- [16] NORSOK Standard D-010, Rev.4, *Well integrity in drilling and well operations*, June 2013
- [17] Picture of Upwind location concept, available at: [https://upload.wikimedia.org/wikipedia/commons/7/75/Upwind\\_downwind\\_example.png](https://upload.wikimedia.org/wikipedia/commons/7/75/Upwind_downwind_example.png), accessed: 3<sup>rd</sup> February 2016

- [18] Schlumberger Glossary, available at: <http://www.glossary.oilfield.slb.com/en.aspx>
- [19] Petroleum Safety Authority of Norway, *Regulations relating to conducting petroleum activities – Section 86 Well Control*, available at: [http://www.psa.no/activities/category399.html#\\_Toc440459215](http://www.psa.no/activities/category399.html#_Toc440459215), accessed: 6<sup>th</sup> February 2016
- [20] Patent US4224989 A, *Method of dynamically killing a well blowout*, September 1980, available at: <http://www.google.com/patents/US4224989>, accessed: 8<sup>th</sup> February 2016
- [21] Smestad, P., Rygg, O.B., Wright, J.W., *Matching known downhole well information with surface flow characteristics of a blowout via computer allows selection of the most efficient kill method*, John Wright Co., Houston, available at: <http://www.jwco.com/technical-literature/p05.htm>, accessed: 8<sup>th</sup> February 2016
- [22] Picture of Relief wells for deep reservoir, available at: [http://1.bp.blogspot.com/\\_4ify7vDXrDs/TCqI5KYkqQI/AAAAAAAAAGI0/O1\\_DkM2QuoM/s1600/relief\\_wells\\_28june.jpg](http://1.bp.blogspot.com/_4ify7vDXrDs/TCqI5KYkqQI/AAAAAAAAAGI0/O1_DkM2QuoM/s1600/relief_wells_28june.jpg), accessed: 10<sup>th</sup> February 2016
- [23] Krainer, B., *Hoop High – Hopes and Challenges*, OMV Norge AS, 2015, available at: <http://www.speworkshop.no/wp-content/uploads/2015/03/Harstad-SPE-Workshop-Presentation-OMV-Final1-11-03-2015.pdf>, accessed: 10<sup>th</sup> February 2016
- [24] Fanavoll, S., Gabrielsen, P.T., Ellingsrud, S., *CSEM as a tool for better exploration decisions: Case studies from the Barents Sea, Norwegian Continental Shelf*, 2014, available at: <http://www.emgs.com/content/1036/CSEM-as-a-tool-for-better-exploration-decisions:-Case-studies-from-the-Barents-Sea-Norwegian-Continental-Shelf>, accessed: 10<sup>th</sup> February 2016
- [25] Wright, J.W., *Relief Well Intersection Design*, Wild Well Control, March 2015, available at: [http://www.iscwsa.net/files/5114/2709/0941/02\\_-\\_Relief\\_Well\\_-\\_John\\_Wright.pdf](http://www.iscwsa.net/files/5114/2709/0941/02_-_Relief_Well_-_John_Wright.pdf), accessed: 11<sup>th</sup> February 2016
- [26] Picture of Wisting and Hanssen segments, Norwegian Petroleum, available at: <http://www.norskipetroleum.no/en/exploration/discovery/73248-1-wisting/>, accessed: 11<sup>th</sup> February 2016
- [27] Norwegian Petroleum Directorate, *FactPages, Exploration drilling results, GiS*, available at: <http://www.npd.no/en/>, accessed: February, March 2016
- [28] Picture of Wisting Prospect Development, available at: [https://encrypted-tbn1.gstatic.com/images?q=tbn:ANd9GcSPMh8ofVgUU9PCi\\_NYGTzy7fojP\\_Oynvmue6ggUcqTQ32ctqkQ](https://encrypted-tbn1.gstatic.com/images?q=tbn:ANd9GcSPMh8ofVgUU9PCi_NYGTzy7fojP_Oynvmue6ggUcqTQ32ctqkQ), accessed: 11<sup>th</sup> February 2016
- [29] Picture of 3D resistivity anomalies of Wisting and Hanssen oil discoveries, available at: <http://www.epmag.com/sites/default/files/styles/article/public/embed-images/2015/04/EMGSFigure%206.jpg?itok=KU7WvkRT>, accessed, 11<sup>th</sup> February 2016
- [30] Marius Ingebrigsten, *PGNiG Barents Sea query*, Acona, October 2015, internal materials
- [31] Map of offshore infrastructure nearby Wisting Prospect, available at: <http://www.environment.no/topics/marine-and-coastal-waters/oil-and-gas-activities/offshore-infrastructure/>, accessed: 14<sup>th</sup> February 2016
- [32] Map of marine traffic on Wisting Prospect, available at: <http://www.marinetraffic.com/en/ais/home/centerx:24/centery:73/zoom:10>, accessed: 14<sup>th</sup> February 2016

- [33] Bathymetric map of considered area, available at: [http://www.mareano.no/en/maps/mareano\\_en.html](http://www.mareano.no/en/maps/mareano_en.html), accessed: 15<sup>th</sup> February 2016
- [34] Earth:: a global map of wind, weather and ocean conditions, available at: <http://earth.nullschool.net/>
- [35] PGNiG Upstream International AS, *Geophysical surveys of Wisting Prospect*, 2015, internal materials
- [36] PetroWiki, *Horizontal wells*, July 2015, available at: [http://petrowiki.org/Horizontal\\_wells](http://petrowiki.org/Horizontal_wells), accessed: 18<sup>th</sup> February 2016
- [37] Krainer, B., *Plans, Leanings & Thoughts – Executive Presentation Arctic Safety Summit*, OMV Norge AS, October 2015, available at: [http://www.ptil.no/getfile.php/PDF/Arctic%20Safety%20Summit/Presentasjoner/05%20-%20Bernhard%20Keiner%20-%20OMV\\_Arctic%20safety%20summit%202015%20\\_Krainer%2013-10.pdf](http://www.ptil.no/getfile.php/PDF/Arctic%20Safety%20Summit/Presentasjoner/05%20-%20Bernhard%20Keiner%20-%20OMV_Arctic%20safety%20summit%202015%20_Krainer%2013-10.pdf), accessed: 21<sup>st</sup> February 2016
- [38] PetroWiki, *Casing and tubing*, June 2015, available at: [http://petrowiki.org/Casing\\_and\\_tubing](http://petrowiki.org/Casing_and_tubing), accessed: 22<sup>nd</sup> February 2016
- [39] Fjelde, K.K., *Drilling program & Drilling problems*, University of Stavanger, 2015
- [40] International Association of Drilling Contractors, *Oil & Gas Drilling Glossary*, available at: <http://www.iadclexicon.org/>, accessed 24<sup>th</sup> February 2016
- [41] Aadnoy, B.S., Soteland, T., Ellingsen, U., *Casing Point Selection at Shallow Depth - abstract*, Society of Petroleum Engineers, 1989
- [42] Nguyen, T., *Well Design PE 413*, New Mexico Tech, 2011
- [43] Baker Hughes, AutoTrak Curve Rotary Steerable System, available at: <http://www.bakerhughes.com/products-and-services/drilling/drilling-services/directional-drilling-services/rotary-steerable-systems/autotrak-curve-rotary-steerable-system>, accessed: 24<sup>th</sup> February 2016
- [44] Bettis, F.E., Schwanitz, B.J., Crane, L., *Limiting dogleg is a key to reducing casing wear*, 1994, available at: <http://www.ogj.com/articles/print/volume-92/issue-31/in-this-issue/drilling/limiting-dogleg-is-a-key-to-reducing-casing-wear.html>, accessed: 24<sup>th</sup> February 2016
- [45] PetroWiki, *Cuttings transport*, June 2015, available at: [http://petrowiki.org/Cuttings\\_transport](http://petrowiki.org/Cuttings_transport), accessed: 25<sup>th</sup> February 2016
- [46] Shah, S.N., Shanker, N.H., Ogugbue, C.C., *Future Challenges of Drilling Fluids and Their Rheological Measurements*, Well Construction Technology Center, Univeristy of Oklahoma, 2010
- [47] Drilling Engineering – PETE 411 Well Drilling, *Drilling Cost & Drilling Rate*, University of Stavanger
- [48] Shuang-jin, Z., Zhi-qiang, H., Hong-jian, W., *A Calculation Method for WOB Conducting of Directional Well*, Laboratory of Drilling Engineering, Yangtze University, 2013
- [49] WiperTrip, Drilling and Well Engineering Resources, *Relief well – Homing in*, available at: <http://www.wipertrip.com/well-control/relief-well-homing-in.html>, accessed: 1<sup>st</sup> March 2016
- [50] Fjelde, K.K., *Directional Drilling - Part 1*, University of Stavanger, 2015

[51] Downton, G., Klausen, T.S., Hendricks, A., Pafitis, D., *New Directions in Rotary Steerable Drilling*, Oilfield Review, Schlumberger, 2000

[52] de Lange, J.I., Darling, T.J., *Improved Detectability of Blowing Wells*, Society of Petroleum Engineers, 1990

[53] Add Energy, Casing Magnetization Service, available at: <https://static1.squarespace.com/static/55d2df17e4b0ada576ce3d06/t/5677bd4ca976af9a4e42da6d/1450687820449/Casing+Magnetization+Services.pdf>, accessed, 10<sup>th</sup> March 2016

[54] Evensen, K., Sangesland, S., Johansen, S.E., Raknes, E.B., Arntsen, B., *Relief Well Drilling Using Surface Seismic While Drilling (SSWD)*, Norwegian University of Science and Technology, Society of Petroleum Engineers, 2014, available at: <http://www.ipt.ntnu.no/~barn/Myabstracts/Evensen2014.pdf>, accessed: 4<sup>th</sup> March 2016

[55] Rygg, O.B., *Montara / West Atlas Blowout and Macondo / Deepwater Horizon Blowout*, Add Energy, 2010

## 11 Chapter XI – Appendixes

### 11.1 Appendix 1 – Derivation of geometrical formulas for trajectory calculations

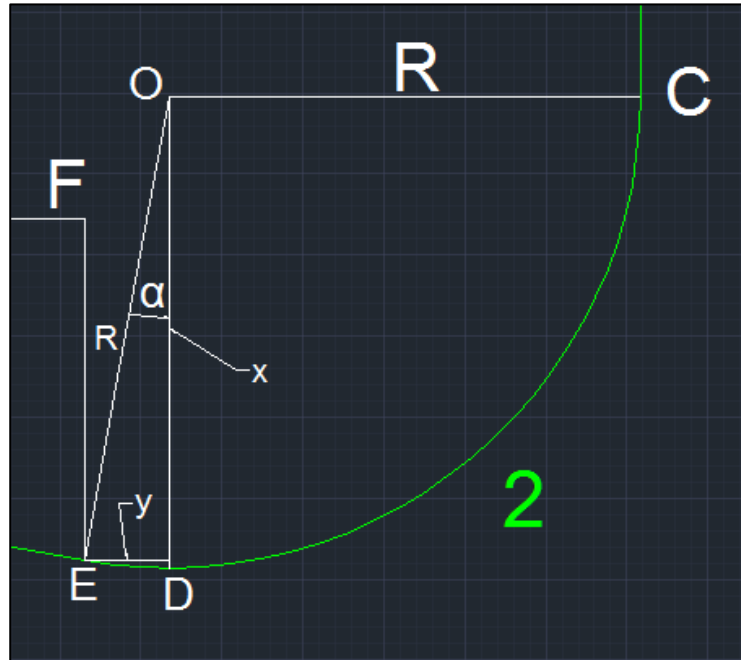

Dogleg angle -  $\Delta i$  [ $^{\circ}$ ] (combined change in azimuth and inclination)

Build length -  $\Delta l$  [m]

Dogleg severity -  $\frac{\Delta i}{\Delta l}$  [ $\frac{^{\circ}}{m}$ ]

Derivation of formula for radius R:

$$\frac{CE}{2\pi R} = \frac{\alpha}{360^{\circ}}$$

$$R = \frac{CE}{2\pi} \cdot \frac{360^{\circ}}{\alpha}$$

$$\frac{\alpha}{CE} = \frac{\Delta i}{\Delta l}$$

$$\alpha = \frac{\Delta i}{\Delta l} \cdot CE$$





11.2 Appendix 2 – Relief well planning table



MD[m]	Inclination[o]	TVD[m]	Azimuth[o]	North[m]	East[m]	C. Depart.[m]	C. Azimuth[o]	V. Section[m]	DLS[o/100ft]
0,00	0,00	0,00	0,00	0,00	0,00	0,00	0,00	0,00	0,00
10,00	0,00	10,00	0,00	0,00	0,00	0,00	0,00	0,00	0,00
20,00	0,00	20,00	0,00	0,00	0,00	0,00	0,00	0,00	0,00
30,00	0,00	30,00	0,00	0,00	0,00	0,00	0,00	0,00	0,00
40,00	0,00	40,00	0,00	0,00	0,00	0,00	0,00	0,00	0,00
50,00	0,00	50,00	0,00	0,00	0,00	0,00	0,00	0,00	0,00
60,00	0,00	60,00	0,00	0,00	0,00	0,00	0,00	0,00	0,00
70,00	0,00	70,00	0,00	0,00	0,00	0,00	0,00	0,00	0,00
80,00	0,00	80,00	0,00	0,00	0,00	0,00	0,00	0,00	0,00
90,00	0,00	90,00	0,00	0,00	0,00	0,00	0,00	0,00	0,00
100,00	0,00	100,00	0,00	0,00	0,00	0,00	0,00	0,00	0,00
110,00	0,00	110,00	0,00	0,00	0,00	0,00	0,00	0,00	0,00
120,00	0,00	120,00	0,00	0,00	0,00	0,00	0,00	0,00	0,00
130,00	0,00	130,00	0,00	0,00	0,00	0,00	0,00	0,00	0,00
140,00	0,00	140,00	0,00	0,00	0,00	0,00	0,00	0,00	0,00
150,00	0,00	150,00	0,00	0,00	0,00	0,00	0,00	0,00	0,00
160,00	0,00	160,00	0,00	0,00	0,00	0,00	0,00	0,00	0,00
170,00	0,00	170,00	0,00	0,00	0,00	0,00	0,00	0,00	0,00
180,00	0,00	180,00	0,00	0,00	0,00	0,00	0,00	0,00	0,00
190,00	0,00	190,00	0,00	0,00	0,00	0,00	0,00	0,00	0,00
200,00	0,00	200,00	0,00	0,00	0,00	0,00	0,00	0,00	0,00
210,00	0,00	210,00	0,00	0,00	0,00	0,00	0,00	0,00	0,00
220,00	0,00	220,00	0,00	0,00	0,00	0,00	0,00	0,00	0,00
230,00	0,00	230,00	0,00	0,00	0,00	0,00	0,00	0,00	0,00
240,00	0,00	240,00	0,00	0,00	0,00	0,00	0,00	0,00	0,00
250,00	0,00	250,00	0,00	0,00	0,00	0,00	0,00	0,00	0,00
260,00	0,00	260,00	0,00	0,00	0,00	0,00	0,00	0,00	0,00
270,00	0,00	270,00	0,00	0,00	0,00	0,00	0,00	0,00	0,00
280,00	0,00	280,00	0,00	0,00	0,00	0,00	0,00	0,00	0,00
290,00	0,00	290,00	0,00	0,00	0,00	0,00	0,00	0,00	0,00
300,00	0,00	300,00	0,00	0,00	0,00	0,00	0,00	0,00	0,00
310,00	0,00	310,00	0,00	0,00	0,00	0,00	0,00	0,00	0,00
320,00	0,00	320,00	0,00	0,00	0,00	0,00	0,00	0,00	0,00
330,00	0,00	330,00	0,00	0,00	0,00	0,00	0,00	0,00	0,00
340,00	0,00	340,00	0,00	0,00	0,00	0,00	0,00	0,00	0,00
350,00	0,00	350,00	0,00	0,00	0,00	0,00	0,00	0,00	0,00
360,00	0,00	360,00	0,00	0,00	0,00	0,00	0,00	0,00	0,00
370,00	0,00	370,00	0,00	0,00	0,00	0,00	0,00	0,00	0,00
380,00	0,00	380,00	0,00	0,00	0,00	0,00	0,00	0,00	0,00
390,00	0,00	390,00	0,00	0,00	0,00	0,00	0,00	0,00	0,00
400,00	0,00	400,00	0,00	0,00	0,00	0,00	0,00	0,00	0,00
410,00	0,00	410,00	0,00	0,00	0,00	0,00	0,00	0,00	0,00
420,00	0,00	420,00	0,00	0,00	0,00	0,00	0,00	0,00	0,00
430,00	0,00	430,00	0,00	0,00	0,00	0,00	0,00	0,00	0,00
440,00	0,00	440,00	0,00	0,00	0,00	0,00	0,00	0,00	0,00
450,00	0,00	450,00	0,00	0,00	0,00	0,00	0,00	0,00	0,00
460,00	0,00	460,00	0,00	0,00	0,00	0,00	0,00	0,00	0,00
470,00	0,00	470,00	0,00	0,00	0,00	0,00	0,00	0,00	0,00
480,00	0,00	480,00	0,00	0,00	0,00	0,00	0,00	0,00	0,00
490,00	0,00	490,00	0,00	0,00	0,00	0,00	0,00	0,00	0,00
500,00	0,00	500,00	0,00	0,00	0,00	0,00	0,00	0,00	0,00
510,00	0,00	510,00	0,00	0,00	0,00	0,00	0,00	0,00	0,00
520,00	0,00	520,00	0,00	0,00	0,00	0,00	0,00	0,00	0,00
523,62	0,00	523,62	0,00	0,00	0,00	0,00	0,00	0,00	0,00
530,00	1,26	530,00	0,00	0,07	0,00	0,07	360,00	0,07	6,00

540,00	3,23	539,99	0,00	0,46	0,00	0,46	360,00	0,46	6,00
550,00	5,19	549,96	0,00	1,20	0,00	1,20	360,00	1,20	6,00
560,00	7,16	559,91	0,00	2,27	0,00	2,27	360,00	2,27	6,00
570,00	9,13	569,80	0,00	3,69	0,00	3,69	360,00	3,69	6,00
580,00	11,10	579,65	0,00	5,44	0,00	5,44	360,00	5,44	6,00
590,00	13,07	589,43	0,00	7,54	0,00	7,54	360,00	7,54	6,00
600,00	15,04	599,13	0,00	9,97	0,00	9,97	360,00	9,97	6,00
610,00	17,00	608,74	0,00	12,73	0,00	12,73	360,00	12,73	6,00
620,00	18,97	618,25	0,00	15,81	0,00	15,81	360,00	15,81	6,00
630,00	20,94	627,65	0,00	19,23	0,00	19,23	360,00	19,23	6,00
640,00	22,91	636,92	0,00	22,96	0,00	22,96	360,00	22,96	6,00
650,00	24,88	646,07	0,00	27,01	0,00	27,01	360,00	27,01	6,00
660,00	26,85	655,06	0,00	31,37	0,00	31,37	360,00	31,37	6,00
670,00	28,82	663,91	0,00	36,04	0,00	36,04	360,00	36,04	6,00
680,00	30,78	672,58	0,00	41,01	0,00	41,01	360,00	41,01	6,00
690,00	32,75	681,09	0,00	46,28	0,00	46,28	360,00	46,28	6,00
700,00	34,72	689,40	0,00	51,83	0,00	51,83	360,00	51,83	6,00
710,00	36,69	697,52	0,00	57,66	0,00	57,66	360,00	57,66	6,00
720,00	38,66	705,44	0,00	63,78	0,00	63,78	360,00	63,78	6,00
730,00	40,63	713,14	0,00	70,16	0,00	70,16	360,00	70,16	6,00
740,00	42,60	720,61	0,00	76,80	0,00	76,80	360,00	76,80	6,00
750,00	44,56	727,86	0,00	83,69	0,00	83,69	360,00	83,69	6,00
760,00	46,53	734,86	0,00	90,83	0,00	90,83	360,00	90,83	6,00
770,00	48,50	741,61	0,00	98,20	0,00	98,20	360,00	98,20	6,00
780,00	50,47	748,11	0,00	105,80	0,00	105,80	360,00	105,80	6,00
790,00	52,44	754,34	0,00	113,62	0,00	113,62	360,00	113,62	6,00
800,00	54,41	760,30	0,00	121,65	0,00	121,65	360,00	121,65	6,00
810,00	56,37	765,98	0,00	129,88	0,00	129,88	360,00	129,88	6,00
820,00	58,34	771,37	0,00	138,30	0,00	138,30	360,00	138,30	6,00
830,00	60,31	776,47	0,00	146,91	0,00	146,91	360,00	146,91	6,00
840,00	62,28	781,27	0,00	155,68	0,00	155,68	360,00	155,68	6,00
850,00	64,25	785,77	0,00	164,61	0,00	164,61	360,00	164,61	6,00
860,00	66,22	789,96	0,00	173,69	0,00	173,69	360,00	173,69	6,00
870,00	68,19	793,84	0,00	182,90	0,00	182,90	360,00	182,90	6,00
880,00	70,15	797,39	0,00	192,25	0,00	192,25	360,00	192,25	6,00
890,00	72,12	800,62	0,00	201,71	0,00	201,71	360,00	201,71	6,00
900,00	74,09	803,53	0,00	211,28	0,00	211,28	360,00	211,28	6,00
910,00	76,06	806,11	0,00	220,94	0,00	220,94	360,00	220,94	6,00
920,00	78,03	808,35	0,00	230,69	0,00	230,69	360,00	230,69	6,00
930,00	80,00	810,25	0,00	240,50	0,00	240,50	360,00	240,50	6,00
940,00	81,97	811,82	0,00	250,38	0,00	250,38	360,00	250,38	6,00
950,00	83,93	813,05	0,00	260,30	0,00	260,30	360,00	260,30	6,00
960,00	85,90	813,93	0,00	270,26	0,00	270,26	360,00	270,26	6,00
970,00	87,87	814,48	0,00	280,25	0,00	280,25	360,00	280,25	6,00
980,00	89,84	814,68	0,00	290,25	0,00	290,25	360,00	290,25	6,00
990,00	91,81	814,53	0,00	300,25	0,00	300,25	360,00	300,25	6,00
1000,00	93,78	814,05	0,00	310,23	0,00	310,23	360,00	310,23	6,00
1010,00	95,74	813,22	0,00	320,20	0,00	320,20	360,00	320,20	6,00
1020,00	97,71	812,04	0,00	330,13	0,00	330,13	360,00	330,13	6,00
1030,00	99,68	810,53	0,00	340,01	0,00	340,01	360,00	340,01	6,00
1031,62	100,00	810,26	0,00	341,61	0,00	341,61	360,00	341,61	6,00
1040,00	100,00	808,80	0,00	349,86	0,00	349,86	360,00	349,86	0,00
1050,00	100,00	807,06	0,00	359,71	0,00	359,71	360,00	359,71	0,00
1060,00	100,00	805,33	0,00	369,56	0,00	369,56	360,00	369,56	0,00
1070,00	100,00	803,59	0,00	379,41	0,00	379,41	360,00	379,41	0,00
1080,00	100,00	801,85	0,00	389,25	0,00	389,25	360,00	389,25	0,00
1090,00	100,00	800,12	0,00	399,10	0,00	399,10	360,00	399,10	0,00
1100,00	100,00	798,38	0,00	408,95	0,00	408,95	360,00	408,95	0,00
1110,00	100,00	796,65	0,00	418,80	0,00	418,80	360,00	418,80	0,00
1120,00	100,00	794,91	0,00	428,65	0,00	428,65	360,00	428,65	0,00
1130,00	100,00	793,17	0,00	438,49	0,00	438,49	360,00	438,49	0,00
1140,00	100,00	791,44	0,00	448,34	0,00	448,34	360,00	448,34	0,00
1150,00	100,00	789,70	0,00	458,19	0,00	458,19	360,00	458,19	0,00
1160,00	100,00	787,96	0,00	468,04	0,00	468,04	360,00	468,04	0,00
1170,00	100,00	786,23	0,00	477,89	0,00	477,89	360,00	477,89	0,00
1180,00	100,00	784,49	0,00	487,74	0,00	487,74	360,00	487,74	0,00
1190,00	100,00	782,75	0,00	497,58	0,00	497,58	360,00	497,58	0,00
1200,00	100,00	781,02	0,00	507,43	0,00	507,43	360,00	507,43	0,00
1210,00	100,00	779,28	0,00	517,28	0,00	517,28	360,00	517,28	0,00
1220,00	100,00	777,54	0,00	527,13	0,00	527,13	360,00	527,13	0,00

1230,00	100,00	775,81	0,00	536,98	0,00	536,98	360,00	536,98	0,00
1240,00	100,00	774,07	0,00	546,82	0,00	546,82	360,00	546,82	0,00
1250,00	100,00	772,33	0,00	556,67	0,00	556,67	360,00	556,67	0,00
1260,00	100,00	770,60	0,00	566,52	0,00	566,52	360,00	566,52	0,00
1270,00	100,00	768,86	0,00	576,37	0,00	576,37	360,00	576,37	0,00
1280,00	100,00	767,12	0,00	586,22	0,00	586,22	360,00	586,22	0,00
1290,00	100,00	765,39	0,00	596,06	0,00	596,06	360,00	596,06	0,00
1300,00	100,00	763,65	0,00	605,91	0,00	605,91	360,00	605,91	0,00
1310,00	100,00	761,92	0,00	615,76	0,00	615,76	360,00	615,76	0,00
1320,00	100,00	760,18	0,00	625,61	0,00	625,61	360,00	625,61	0,00
1330,00	100,00	758,44	0,00	635,46	0,00	635,46	360,00	635,46	0,00
1340,00	100,00	756,71	0,00	645,30	0,00	645,30	360,00	645,30	0,00
1350,00	100,00	754,97	0,00	655,15	0,00	655,15	360,00	655,15	0,00
1360,00	100,00	753,23	0,00	665,00	0,00	665,00	360,00	665,00	0,00
1370,00	100,00	751,50	0,00	674,85	0,00	674,85	360,00	674,85	0,00
1380,00	100,00	749,76	0,00	684,70	0,00	684,70	360,00	684,70	0,00
1390,00	100,00	748,02	0,00	694,54	0,00	694,54	360,00	694,54	0,00
1400,00	100,00	746,29	0,00	704,39	0,00	704,39	360,00	704,39	0,00
1410,00	100,00	744,55	0,00	714,24	0,00	714,24	360,00	714,24	0,00
1420,00	100,00	742,81	0,00	724,09	0,00	724,09	360,00	724,09	0,00
1430,00	100,00	741,08	0,00	733,94	0,00	733,94	360,00	733,94	0,00
1440,00	100,00	739,34	0,00	743,79	0,00	743,79	360,00	743,79	0,00
1450,00	100,00	737,60	0,00	753,63	0,00	753,63	360,00	753,63	0,00
1460,00	100,00	735,87	0,00	763,48	0,00	763,48	360,00	763,48	0,00
1470,00	100,00	734,13	0,00	773,33	0,00	773,33	360,00	773,33	0,00
1480,00	100,00	732,40	0,00	783,18	0,00	783,18	360,00	783,18	0,00
1490,00	100,00	730,66	0,00	793,03	0,00	793,03	360,00	793,03	0,00
1500,00	100,00	728,92	0,00	802,87	0,00	802,87	360,00	802,87	0,00
1510,00	100,00	727,19	0,00	812,72	0,00	812,72	360,00	812,72	0,00
1520,00	100,00	725,45	0,00	822,57	0,00	822,57	360,00	822,57	0,00
1530,00	100,00	723,71	0,00	832,42	0,00	832,42	360,00	832,42	0,00
1540,00	100,00	721,98	0,00	842,27	0,00	842,27	360,00	842,27	0,00
1550,00	100,00	720,24	0,00	852,11	0,00	852,11	360,00	852,11	0,00
1560,00	100,00	718,50	0,00	861,96	0,00	861,96	360,00	861,96	0,00
1570,00	100,00	716,77	0,00	871,81	0,00	871,81	360,00	871,81	0,00
1580,00	100,00	715,03	0,00	881,66	0,00	881,66	360,00	881,66	0,00
1590,00	100,00	713,29	0,00	891,51	0,00	891,51	360,00	891,51	0,00
1600,00	100,00	711,56	0,00	901,35	0,00	901,35	360,00	901,35	0,00
1610,00	100,00	709,82	0,00	911,20	0,00	911,20	360,00	911,20	0,00
1620,00	100,00	708,08	0,00	921,05	0,00	921,05	360,00	921,05	0,00
1630,00	100,00	706,35	0,00	930,90	0,00	930,90	360,00	930,90	0,00
1640,00	100,00	704,61	0,00	940,75	0,00	940,75	360,00	940,75	0,00
1650,00	100,00	702,88	0,00	950,59	0,00	950,59	360,00	950,59	0,00
1660,00	100,00	701,14	0,00	960,44	0,00	960,44	360,00	960,44	0,00
1670,00	100,00	699,40	0,00	970,29	0,00	970,29	360,00	970,29	0,00
1680,00	100,00	697,67	0,00	980,14	0,00	980,14	360,00	980,14	0,00
1690,00	100,00	695,93	0,00	989,99	0,00	989,99	360,00	989,99	0,00
1700,00	100,00	694,19	0,00	999,84	0,00	999,84	360,00	999,84	0,00
1710,00	100,00	692,46	0,00	1009,68	0,00	1009,68	360,00	1009,68	0,00
1720,00	100,00	690,72	0,00	1019,53	0,00	1019,53	360,00	1019,53	0,00
1730,00	100,00	688,98	0,00	1029,38	0,00	1029,38	360,00	1029,38	0,00
1740,00	100,00	687,25	0,00	1039,23	0,00	1039,23	360,00	1039,23	0,00
1750,00	100,00	685,51	0,00	1049,08	0,00	1049,08	360,00	1049,08	0,00
1760,00	100,00	683,77	0,00	1058,92	0,00	1058,92	360,00	1058,92	0,00
1770,00	100,00	682,04	0,00	1068,77	0,00	1068,77	360,00	1068,77	0,00
1780,00	100,00	680,30	0,00	1078,62	0,00	1078,62	360,00	1078,62	0,00
1790,00	100,00	678,56	0,00	1088,47	0,00	1088,47	360,00	1088,47	0,00
1800,00	100,00	676,83	0,00	1098,32	0,00	1098,32	360,00	1098,32	0,00
1810,00	100,00	675,09	0,00	1108,16	0,00	1108,16	360,00	1108,16	0,00
1820,00	100,00	673,35	0,00	1118,01	0,00	1118,01	360,00	1118,01	0,00
1830,00	100,00	671,62	0,00	1127,86	0,00	1127,86	360,00	1127,86	0,00
1840,00	100,00	669,88	0,00	1137,71	0,00	1137,71	360,00	1137,71	0,00
1850,00	100,00	668,15	0,00	1147,56	0,00	1147,56	360,00	1147,56	0,00
1860,00	100,00	666,41	0,00	1157,40	0,00	1157,40	360,00	1157,40	0,00
1870,00	100,00	664,67	0,00	1167,25	0,00	1167,25	360,00	1167,25	0,00
1880,00	100,00	662,94	0,00	1177,10	0,00	1177,10	360,00	1177,10	0,00
1890,00	100,00	661,20	0,00	1186,95	0,00	1186,95	360,00	1186,95	0,00
1900,00	100,00	659,46	0,00	1196,80	0,00	1196,80	360,00	1196,80	0,00
1910,00	100,00	657,73	0,00	1206,64	0,00	1206,64	360,00	1206,64	0,00
1920,00	100,00	655,99	0,00	1216,49	0,00	1216,49	360,00	1216,49	0,00

1930,00	100,00	654,25	0,00	1226,34	0,00	1226,34	360,00	1226,34	0,00
1940,00	100,00	652,52	0,00	1236,19	0,00	1236,19	360,00	1236,19	0,00
1950,00	100,00	650,78	0,00	1246,04	0,00	1246,04	360,00	1246,04	0,00
1960,00	100,00	649,04	0,00	1255,89	0,00	1255,89	360,00	1255,89	0,00
1970,00	100,00	647,31	0,00	1265,73	0,00	1265,73	360,00	1265,73	0,00
1980,00	100,00	645,57	0,00	1275,58	0,00	1275,58	360,00	1275,58	0,00
1990,00	100,00	643,83	0,00	1285,43	0,00	1285,43	360,00	1285,43	0,00
2000,00	100,00	642,10	0,00	1295,28	0,00	1295,28	360,00	1295,28	0,00
2010,00	100,00	640,36	0,00	1305,13	0,00	1305,13	360,00	1305,13	0,00
2020,00	100,00	638,63	0,00	1314,97	0,00	1314,97	360,00	1314,97	0,00
2030,00	100,00	636,89	0,00	1324,82	0,00	1324,82	360,00	1324,82	0,00
2040,00	100,00	635,15	0,00	1334,67	0,00	1334,67	360,00	1334,67	0,00
2050,00	100,00	633,42	0,00	1344,52	0,00	1344,52	360,00	1344,52	0,00
2060,00	100,00	631,68	0,00	1354,37	0,00	1354,37	360,00	1354,37	0,00
2070,00	100,00	629,94	0,00	1364,21	0,00	1364,21	360,00	1364,21	0,00
2080,00	100,00	628,21	0,00	1374,06	0,00	1374,06	360,00	1374,06	0,00
2090,00	100,00	626,47	0,00	1383,91	0,00	1383,91	360,00	1383,91	0,00
2100,00	100,00	624,73	0,00	1393,76	0,00	1393,76	360,00	1393,76	0,00
2110,00	100,00	623,00	0,00	1403,61	0,00	1403,61	360,00	1403,61	0,00
2120,00	100,00	621,26	0,00	1413,45	0,00	1413,45	360,00	1413,45	0,00
2130,00	100,00	619,52	0,00	1423,30	0,00	1423,30	360,00	1423,30	0,00
2140,00	100,00	617,79	0,00	1433,15	0,00	1433,15	360,00	1433,15	0,00
2150,00	100,00	616,05	0,00	1443,00	0,00	1443,00	360,00	1443,00	0,00
2160,00	100,00	614,31	0,00	1452,85	0,00	1452,85	360,00	1452,85	0,00
2170,00	100,00	612,58	0,00	1462,69	0,00	1462,69	360,00	1462,69	0,00
2180,00	100,00	610,84	0,00	1472,54	0,00	1472,54	360,00	1472,54	0,00
2190,00	100,00	609,11	0,00	1482,39	0,00	1482,39	360,00	1482,39	0,00
2200,00	100,00	607,37	0,00	1492,24	0,00	1492,24	360,00	1492,24	0,00
2207,88	100,00	606,00	0,00	1500,00	0,00	1500,00	360,00	1500,00	0,00