



Faculty of Science and Technology

MASTER'S THESIS

Study program/ Specialization: Offshore Technology/ Marine and Subsea Technology	Spring semester, 2016 Restricted access
Writer: Lars Alexander Eikeland (Writer's signature)
Faculty supervisor: Ove Tobias Gudmestad, Professor, University of Stavanger	
Thesis title: Development of a Wave-Driven Pump for Energy Production	
Credits (ECTS): 30	
Key words: Elongating member, Energy production, Fluid displacement, Ocean wave, Offshore, Pump, Renewable energy, Wave Energy Converter, Wave Energy Plant, Wave utilization	Pages: 99 + enclosure: 35 + Compact Disc Stavanger, 15. June 2016

ABSTRACT

Since the year of 2014, the oil and gas industry worldwide has experienced a backlash from years of prosperous field developments and implementation of technology for improved recovery. Overproduction of oil and gas has resulted in a tremendous fall in price, halting ongoing projects and rendering initiation of new projects inviable. For countries such as Norway, where the consequences of this recession are severe, authorities are reminded of the fragility of the industry. This brings forth renewed attention to neighbouring industries, such as wind- and wave energy.

As governments and large energy companies are turning their attention towards renewable energy, 2016 has become an opportune time for developers and inventors of renewable energy technology to attain funding for continued development. In Norway, there has been a growing focus on wind energy. Still one does not need to travel far to reach countries with increasing interests in ocean wave energy.

This document presents a new concept for harvesting the energy of motion in ocean waves for production of electric energy and as a method of transporting seawater to a desalination plant. The concept is the student's contribution to the world's arsenal of renewable energy alternatives and a proposal to help satisfying the global demand for clean water.

With focus on the process of product and technology development, the report comprises the stepwise process from generating an idea to conceptual testing and proof of concept. This includes describing the train of thoughts regarding how the concept is supposed to function and expressing how this is new compared to other concepts. The process also includes generation of multiple potentially marketable products based on the concept, and selection of the product deemed best suited for further development into a commercial product. This was done by the combination of following an industry-used product development process and implementing problem-solving solutions inspired by- or already used in the oil and gas industry.

Furthermore, the report covers the concept's mode of operations. This laid the foundation for determining an embryonic conclusion to the concept's energy production potential, a milestone that to most new concepts determines the project's ability to succeed in the form of "sink or swim". The final part of the project regards the development of a prototype for conducting various tests, from which an array of design criteria could be determined. The establishment of these criteria, however, will only serve its purpose if the concept-development project is allowed the opportunity of continuation post thesis. Typically initiated either from funding granted by the government, or by corporate takeover from sale of the idea.

ACKNOWLEDGEMENTS

First of all I would like to express my gratitude to Professor Ove Tobias Gudmestad. He not only taught me much of the theory required to reach my goals in this project, but also allowed me to pursue the development of the concept as part of my education.

Secondly, I would like to thank John Charles Grønli for all his help and advice, with special reference to the component suggestion that may well have saved a lot of time in the construction phase of my project.

Conducting the tensile tests as part of this project could not have been achieved without the assistance of Samdar Kakay, who took the necessary time to assist me even when his availability was stretched thin.

Much gratitude goes to Martin Bae for his welding assistance. His welding speed and quality was both an inspiration and an asset during this project.

Special thanks goes to Nils-Ottar Antonsen and Bergen University College for showing great collaboration by allowing me to use their new wave pool facility. Not to mention the cheerful assistance of Harald Moen, who helped me fulfill all my testing needs in the short time available.

Finally, I would like to thank my father for all his support, assistance and advice both throughout this project and my education as a whole.

TABLE OF CONTENTS

LIST OF FIGURES.....	xi
LIST OF TABLES	xii
ABBREVIATIONS AND ACRONYMS	xiii
LATIN SYMBOLS	xv
GREEK SYMBOLS.....	xvii
CHAPTER 1 – INTRODUCTION	1
1.1 BACKGROUND.....	1
1.2 PROBLEM STATEMENT	1
1.3 PROJECT PURPOSE AND SCOPE	2
1.4 MOTIVATION AND INSPIRATION.....	2
1.5 THESIS SYNOPSIS	3
CHAPTER 2 – GROUNDWORK THEORY	5
2.1 PRODUCT DESIGN & DEVELOPMENT	5
2.1.1 Market-pull product development process	5
2.1.2 Concept development.....	7
2.1.3 From development process to thesis	9
2.2 INTELLECTUAL PROPERTY	10
2.2.1 Patent.....	10
2.2.2 How to write a patent	12
2.3 HYDROSTATIC PRESSURE.....	13
2.3.1 Buoyancy.....	14
2.4 WAVES AND WAVE ENERGY	15
2.4.1 Wind waves	15
2.4.2 Linear waves	16
2.4.3 Irregular waves.....	18
2.5 TIDE.....	22
2.6 WAVE ENERGY PLANTS.....	22
2.6.1 Oscillating water column	23
2.6.2 Buoy	24
2.6.3 Overtopping.....	25
2.6.4 Sea snake	26
CHAPTER 3 – THE CONCEPT.....	27
3.1 CONCEPT NAME AND POTENTIAL TRADEMARK.....	27

3.2 CONCEPT DESCRIPTION.....	27
3.3 THE PUMPING MECHANISM.....	28
3.3.1 Version 1. Dual purpose.....	29
3.3.2 Version 2. Energy production	29
3.4 PUMP MECHANISM CONCEPTUAL CHALLENGES	30
CHAPTER 4 – PRODUCT CONCEPT GENERATION.....	33
4.1 CONCEPT GENERATION	33
4.2 THE JACKET PLATFORM CONCEPT.....	34
4.3 THE JACK-UP PLATFORM CONCEPT	37
4.4 THE BUOY CONCEPT.....	39
4.5 CONCEPT SELECTION	41
CHAPTER 5 – PLATFORM ELEVATION.....	45
5.1 ELEVATION AND AIR GAP OVERVIEW	45
5.2 CALCULATING ELEVATION	46
5.2.1 Location of operation	46
5.2.2 Calculating wave crest and elevation requirement.....	47
CHAPTER 6 – PUMP DESIGN & THEORETICAL EFFICIENCY	51
6.1 PUMP DESIGN CRITERIA	51
6.2 PUMP DESIGN OPERATIONAL BOUNDARIES.....	52
6.2.1 Pump operating principle 1	54
6.2.2 Pump operating principle 2	54
6.3 PUMP DESIGN PROPOSAL.....	55
6.4 THEORETICAL EFFICIENCY	55
CHAPTER 7 – PROTOTYPE TESTING.....	63
7.1 PROTOTYPE DESCRIPTION.....	63
7.1.1 Buoyancy module motions.....	65
7.1.2 Balloon characteristics	66
7.1.3 The pump’s Eigen-period.....	68
7.1.4 The balloon’s circumference	70
7.2 PURPOSE OF TESTS	71
7.3 THE TESTS	73
7.3.1 Test I – Validating the technology in laboratory.....	74
7.3.2 Test II – Determining the prototype’s productivity	75

7.3.3 Test III – Validating the technology in relevant environment	78
7.3.4 Test IV – Determining the prototype’s productivity in wave pool	80
7.3.5 Test V – Checking for excessive bending in higher waves.....	82
7.3.6 Test VI – Determining pump operating principle 1	85
7.3.7 Test VII – Determining pump operating principle 2.....	87
7.3.8 Test VIII – Determining the impact of sloshing	90
7.3.9 Test IX – Determining the influence of draft distribution	92
7.3.10 Summarised conclusions	95
CHAPTER 8 – CONCLUDING REMARKS	97
8.1 DISCUSSIONS	97
8.2 CONCLUSIONS	98
8.3 FURTHER WORK	99
REFERENCES.....	101
LIST OF APPENDICES	105
APPENDIX A – REVIEW OF LINEAR WAVE THEORY FORMULAS	106
APPENDIX B – TIDE PREDICTION TABLE OF STAVANGER COAST 2016	107
APPENDIX C – SIGNED DRAFT OF NORWEGIAN PATENT APPLICATION OF PUMPING MECHANISM	111
APPENDIX D – DRAFT OF ENGLISH PATENT APPLICATION OF PUMPING MECHANISM	115
APPENDIX E – CALCULATIONS OF ENVIRONMENTAL CONTOUR METHOD.....	120
APPENDIX F – TECHNICAL DRAWINGS OF THE PROTOTYPE.....	121

LIST OF FIGURES

Figure 1. Concept development process	7
Figure 2. Flow chart of the development process as part of this thesis.....	9
Figure 3. Contracting states of the Patent Cooperation Treaty marked in blue	11
Figure 4. Illustration of hydrostatic pressure on a submerged cube.....	14
Figure 5. Illustration of waves generated by wind blowing across the ocean surface	15
Figure 6. Increasing wave energy with wave height	18
Figure 7. Series of set of regular waves	19
Figure 8. Wave height probability distribution	19
Figure 9. Examples of wave energy spectra for seas at various stages	20
Figure 10. Global wave energy chart	21
Figure 11. Elliptic shaped ocean caused by gravitational pull.....	22
Figure 12. Oscillating Water Column	24
Figure 13. Illustration of the wave power plant outside Sotenäs	24
Figure 14. Carnegie Wave Energy submerged buoy concept CETO5 and CETO 6	25
Figure 15. Wave dragon concept.....	26
Figure 16. The Pelamis sea snake	26
Figure 17. Potential AWACE Production logo	27
Figure 18. AWACE Production concept draft	28
Figure 19. Pump mechanism for open system concept.....	29
Figure 20. Pump mechanism for closed system concept	30
Figure 21. Desired vs. undesired balloon-wave interaction.....	31
Figure 22. Balloon elongation and return.....	31
Figure 23. AWACE Production housing concepts.....	34
Figure 24. Jacket platform concept	35
Figure 25. Jack-up platform concept.....	37
Figure 26. Floating buoy concept.....	39
Figure 27. Illustration of crest elevation and air gap.....	45
Figure 28. Proposed location of operation	46
Figure 29. JONSWAP wave energy spectrum with shape parameters $\gamma =1$, $\gamma =2$ and $\gamma =5$	48
Figure 30. AWACE Production pump's sectional build-up	51
Figure 31. Illustration of pump mechanism operating in waves	53
Figure 32. Measurements of pump design proposal	55
Figure 33. Hydraulic turbine selection chart and likely production rate.....	58
Figure 34. Yearly electric energy production.....	61
Figure 35. Inventor model of the prototype	63
Figure 36. Inventor model of the prototype in exploded view	64
Figure 37. The buoyancy module's six degrees of freedom	65
Figure 38. Balloon tensile test setup	66
Figure 39. Test results of balloon tensile test.....	67
Figure 40. Average stress-strain curve of the balloon.....	67
Figure 41. Balloon spring-stiffness curve	68
Figure 42. The Eigen-period of the pump at various stages of balloon elongation	69
Figure 43. Balloon bulging at 100 per cent elongation and containing 0.7 litres of water	70

Figure 44. The prototype with the balloon circumferentially constrained with shoelaces	71
Figure 45. Water level in measuring tube as part of Test I and proof of concept.....	74
Figure 46. Maximum measured head in the various measuring tubes	76
Figure 47. Displaced water volume compared to balloon's undeformed internal volume	76
Figure 48. Ratio between the dynamic and static load case of water level height produced ...	77
Figure 49. Tube couplings connected to tube of 1 1/4", 1", 3/4" and 1/2"	78
Figure 50. Picture of the prototype constrained to a carriage above the wave pool	79
Figure 51. The pump operating with the BM in the trough and crest, respectively.....	80
Figure 52. Picture of the prototype located behind a glass wall in the wave pool.....	81
Figure 53. Head produced with various measuring tubes by hand and in wave pool.....	81
Figure 54. Picture sequence of the pump operating in wave system; H=200[mm], T=2[s]	84
Figure 55. Illustration of BM orientation through a wave cycle in high waves.....	85
Figure 56. Picture sequence of pump in wave system; H=40[mm], T=3[s]	86
Figure 57. Picture sequence of pump in wave system; H=40[mm], T=0.58[s]	86
Figure 58. Illustration of the BM's heave motion in the wave zone.....	87
Figure 59. Picture sequence of pump in wave system; H=40[mm], T=0.71[s]	88
Figure 60. Illustrative recreation of the BM's heave motion curve in resonance	89
Figure 61. Illustration of sloshing in the BM during a wave cycle.....	90
Figure 62. Picture sequence of pump with empty BM in wave system; H=160[mm], T=3[s] 91	
Figure 63. Picture sequence of pump with BM half-filled with water in wave system; H=160[mm], T=3[s].....	91
Figure 64. Illustration of the BM floating with and without payload	93
Figure 65. Picture sequence of pump without payload on BM in wave system; H=160[mm], T=3[s].....	93
Figure 66. Illustration of wave force impact on submerged BM with uneven draft	94

LIST OF TABLES

Table 1. Generic market-pull product development process.....	6
Table 2. Concept housing scoring matrix.....	42
Table 3. Feasible swell sea states	56
Table 4. Wave system effectiveness classification	56
Table 5. Sea state description and hydraulics overview for balloon with 4[m] diameter	59
Table 6. Sea state description and hydraulics overview for balloon with 5[m] diameter	60
Table 7. Loads and effects on the AWACE Production pump	72
Table 8. Technology Readiness Level	73
Table 9. Overview of the tests conducted with the prototype	73
Table 10. Comparison of BM motion between scenario with and without water in BM	92
Table 11. Comparison of BM motion between scenario with and without payload on BM....	94
Table 12. Design recommendations for future design work based on test results	95

ABBREVIATIONS AND ACRONYMS

AWACE	Autonomous Water And Clean Energy
BM	Buoyancy Module
CE	Crest Elevation
CFD	Computational Fluid Dynamics
CoB	Centre of Buoyancy
CoG	Centre of Gravity
DAF	Dynamic Amplification Factor
DNV	Det Norske Veritas
DOF	Degrees of Freedom
EPC	European Patent Convention
FPSO	Floating Production, Storage and Offloading
HAT	Highest Astronomical Tide
IP	Intellectual Property
JONSWAP	Joint North Sea Wave Project
MSL	Mean Sea Level
MWL	Mean Water Level
O&G	Oil and Gas
OWC	Oscillating Water Column
PCT	Patent Cooperation Treaty
R&D	Research and development
SE	Surface Elevation
SWL	Still Water Level
TRL	Technology Readiness Level

USA	United States of America
WEC	Wave Energy Converter
WIPO	World Intellectual Property Organisation

LATIN SYMBOLS

A	Area
A_b	Balloon internal cross sectional area
A_{tp}	Turbine pipe internal cross sectional area
A_w	Waterline area
a	Air gap height
a_{\min}	Smallest air gap height
c	Wave phase velocity
c_g	Wave group velocity
d	Water depth
d_b	Balloon internal diameter
d_{tp}	Turbine pipe internal diameter
E	Average wave energy density
F	Force
F_C	Forristall wave crest
g	Gravity acceleration constant
H	Wave height
H_{\max}	Maximum wave height
H_s	Significant wave height
h	Water column height
h_{ce}	Crest elevation height
h_e	Platform elevation height
h_{HAT}	Height of highest astronomical tide
$h_{o,\max}$	Maximum wave height for operation
h_{ss}	Height of storm surge
h_{wc}	Wave crest height
k	Wave number
k_b	Balloon spring stiffness
k_w	Waterline spring stiffness
k_1	Intermediate wave number
L	Wavelength
l_b	Balloon length

$l_{bm,dry}$	Length of dry section of buoyancy module
$l_{e,min}$	Minimum length requirement of balloon elongation
m	Mass
m_a	Hydrodynamic added mass
m_c	Mass of contained liquid
m_p	Mass of pump
m_0	Zeroth order moment
N_{3h}	Number of waves in three-hour storm
P	Pressure
P_o	Atmospheric pressure
P_{pump}	Pump output power
$P_{pump,e}$	Pump effective output power
$P_{pump,yearly}$	Pump effective output power yearly
Q_1	Volume flow rate in
Q_2	Volume flow rate out
R	Radius
r	Position vector
S	Wave energy spectrum
S_1	Wave steepness
T	Wave period
T_h	Heave Eigen-period
T_p	Wave peak period
T_z	Zero-upcrossing wave period
T_1	Mean wave period
t	Time
U_{rs}	Ursell number
u	Velocity component in the x-direction
V	Volume
v_1	Pump retraction velocity
v_2	Fluid flow velocity in turbine
W	Weight
w	Velocity component in the z-direction
x, y, z	Distance from origin on respective axis

GREEK SYMBOLS

α	Wave parameter
α_c	Weibull parameter
β	Wave parameter
β_c	Weibull parameter
γ	Wave energy spectrum shape parameter
Δ	Change
η	Wave surface profile
η_u	Wave energy utilization
η_w	Wave system effectiveness
π	Pi
ρ	Density
ρ_o	Hydraulic fluid density
ρ_{sw}	Seawater density
ρ_w	Water density
φ	Velocity potential
ω	Angular frequency

CHAPTER 1 – INTRODUCTION

This chapter covers the background for the idea of the wave-energy utilization concept and introduces the problems that must be dealt with while developing a new method for wave energy utilization. The chapter also covers the motivation and inspiration that brought to life this new concept. The chapter closes with a short description of the remaining chapters of this thesis document.

1.1 BACKGROUND

The global world is today dealing with a range of challenging issues. Two of these issues are of major significance. The first issue concerns meeting the needs of an increasing energy demand, all the while reducing the affiliated pollution. The second issue is the requirement to satisfy the need for clean water.

There is continuous progress in developing new ways of procuring clean water and electric energy, in addition to improving current methods. The main driver for this development is the tremendous demand. In the case of energy demand, electric energy can arguably not be regarded as a basic need in the same way as clean water. Yet, there is increasing demand in both developed and developing countries. For the case of clean drinking water, even while ignoring the fact that the global population is increasing, there is a recognized demand as a large part of the global world is in deficit. In addition, there are areas like California in the United States of America (USA) where the current demand for drinking water is met, but the subsurface reservoirs are being depleted and implementing alternative methods for obtaining clean water is in an ongoing race against the consumption rate.

Even with such a need for drinking water, there are obstacles that slow the progress of solving this problem. The main obstacle is the economic issue. Technology and innovation has a tendency to follow the money, and there is a clear correlation between a region's clean water deficiency and its financial strength. A potential solution for this can be to combine the production of clean water and electric energy under a single concept. By doing so, it is possible to develop technology for producing clean water, driven by the financial gain of developing technology for energy generation.

1.2 PROBLEM STATEMENT

There is an array of concepts for producing consumer-friendly electric energy. However, the big issue is to refrain from methods that leave a significant carbon footprint or have a negative impact on the local environment or wildlife. These are issues that must be taken into consideration while developing a new concept for energy production.

Also important is the issue of design. Time and time again, offshore equipment are designed and tested on a sound theoretical basis in the sense that the equipment will function as designed. Yet in practise, the equipment is vulnerable to bad weather and a single storm can terminate the project/installation. Vital for the design of wave energy converters, is developing a concept that is able to efficiently utilize the waves, but also able to survive their impact.

There is another important issue to be addressed, concerning the financial aspect. The general understanding while developing something new is that the product has to be either cheaper to

make, simpler to operate or more efficient than current products. This understanding is a guiding rule to prevent developers from squandering time and resources on a product that investors do not believe in or consumers do not want to purchase. In the case of developing a new method of utilizing wave energy to produce electric energy, the concept is compared not only to other wave energy concepts, but all renewable energy concepts feasible for a particular region.

1.3 PROJECT PURPOSE AND SCOPE

The purpose of this project was to initialize the development of a new product based on the student-invented concept for utilizing the energy and motion of ocean waves. The development process comprises development of a small-scale prototype to prove the concept and to determine various design criteria for future design work. The thesis also has a continuous focus on the industry-used process of developing a new product/technology.

Project scope:

- Attain an overview of current concepts for wave energy utilization and establish the advantages and disadvantages of these concepts.
- Thoroughly explain the student's concept in detail with focus on the pumping mechanism that utilizes the energy and motion of the ocean waves.
- Design the pumping mechanism that constitute the heart of wave utilization method.
- Propose a variety of housing concepts to function as the base/foundation of the pumping mechanism and outline the characteristics of the individual concepts.
- Establish an embryonic production efficiency of the concept
- Develop a prototype to prove the concept and establish multiple requirements for optimising design of the pumping mechanism for future work.
- Discuss further work and conclude the concept development project.

1.4 MOTIVATION AND INSPIRATION

Ideas can come and go and it is said that one must avail oneself of the opportunity of developing them to more than just a thought. This can first and foremost be done by writing down the idea on a piece of paper. Write down the idea, perform a quick check of the idea's feasibility and investigate if the idea in fact is new. Such a process can be done with relatively little effort and can aid the inventor to quickly determine whether it would be beneficial to take it a step further or not. This process imparts the message that every product existing today started as just an idea.

The idea for the wave utilization concept for energy production was inspired through the teachings of some of the courses that forms part of the Master of Science program 'Offshore technology: Marine- and subsea technology', held at the *University of Stavanger*. The particular source of inspiration was the issue of air gap design for offshore production- and drilling platforms used in the oil and gas industry. It was the sense of something being amiss considering a sturdy piece of construction located directly above an endless source of renewable energy, yet only considered an annoyance. This got the thoughts rolling, and through almost a year of reflective thinking, resulted into the topic of this master thesis.

1.5 THESIS SYNOPSIS

Chapter 2 introduces basic theory important to the field of wave energy, covering topics such as hydrostatic pressure, and wave- motion and energy. The chapter also examines the science of product development and intellectual property, important to the process of developing new technology.

Chapter 3 presents the student's concept as a whole and describes the stepwise process of the pumping mechanism without addressing detailed engineering.

Chapter 4 presents three product proposals using the pumping mechanism and discusses the pros and cons with each of these three concepts.

Chapter 5 argues for the selected area of operation in case development of a full-scale prototype becomes within reach. Based on the selected area, the chapter also establishes the required platform elevation for the concept chosen in the previous chapter.

Chapter 6 examines the various design criteria and boundaries of the pump mechanism. The chapter also explores a theoretical electric energy production efficiency for the pump in various sea states.

Chapter 7 presents the prototype developed for this thesis, examines the tests conducted using the prototype and discusses the results of said tests.

Chapter 8 covers a discussion of what lies ahead on the path to developing the concept to a market product. The chapter also concludes the thesis, to be followed by a list of references and the attached documents.

CHAPTER 2 – GROUNDWORK THEORY

Through the process of turning an idea into a fully functional system, developers must be able to overcome a range of challenges. Typical challenges reside in the topics of profitability, intellectual property right infringement, financial funding, government cooperation and detailed engineering. There is no guarantee for success for a potential project such as for this student concept. Yet the chance for success increases significantly with the right resources, perseverance, experience and theoretical knowledge to support every decision along the way. This chapter examines the core theory that constitutes the basis for decisions made by the student throughout this document. The chapter will also give the target reader a chance of rehearsing the relevant theory and grant a smooth transition into the many challenges related to developing a new concept for wave energy utilization.

2.1 PRODUCT DESIGN & DEVELOPMENT

Developing a new product can feel like wandering in the dark and looking for something you cannot see, hoping not to stumble. This may especially be the case if you are inexperienced in the field. Though it need not be so, and better yet, this should not be the case. Like most projects, development of a new product requires a well-defined and structured process with achievable milestones.

One of the first steps of developing a new product is defining the category in which the product falls. There are two categories, where the first is *technology-push products* and the second is *market-pull products*. Technology-push products are the result of research and development of new technology. The new technology opens the doors for development of completely new products as well as improvement of- and add-ons to existing products. This type of product usually does not start with market research, but tends to originate from a Research & Development (R&D) department in a larger company. Only later to be packaged in the form of a product and then marketed (Ryan, 2013).

As for the second category, market-pull products are the result of market research indicating a need for a product to solve a specific issue. High-degree success of such a product is usually the result of a finely tuned iterative process of developing with skilled engineers and adjusting according to the customer's needs.

2.1.1 Market-pull product development process

The wave energy converter unit developed in this document is the result of a market need for clean energy and clean water, and is thus a market-pull product. With the category established, the so desired process may then be defined. The market-pull product development process will vary with both company and product type. Nevertheless, a generic development process for market-pull products do exist and is described in Table 1. The process is of an intricate nature and will not be examined in close detail, but be limited to an overview of the initiation phase of the process.

The process starts with conducting market research often initialized by identifying the potential customers. This normally takes part in the *stakeholder identification and analysis* process in the initial project phase. While it is easy to identify some stakeholders, identifying them all can prove difficult. Brainstorming, the Crawford slip method and brain-writing are powerful

Development of a Wave-Driven Pump for Energy Production

techniques for overcoming this issue (Gardiner, 2005). Once the stakeholders are identified, the easiest way of conducting a thorough market research is by mapping the importance of the stakeholders and then ask a lot of questions. Central questions to customers are in the form of “which product(s) do you use today?” and “what are the pros and cons of this/these products?”.

The market research should be thoroughly executed, but time and resources should not be squandered on the initial research. Realizing that market research is not a one-time ordeal, but is iterative with the design process, it is not completed until the product is ready for production and distribution. As part of designing in accordance with the stakeholder’s needs identified in market research, several concepts or designs are developed. The concepts are graded and evaluated amongst the engineering team(s), but may also be further evaluated in rounds of follow-up questions with the stakeholders to get feedback on the concepts and also to identify the best concept for further development.

Table 1. Generic market-pull product development process (Robert Q. Riley Enterprises, 2016)

Concept Development	System-Level Design	Detail Design	Testing and Refinement	Production Ramp-up
Marketing				
➤ Define market segment	➤ Develop plan for product options and extended product family	➤ Develop marketing plan	➤ Develop promotion and launch materials ➤ Facilitate field tests	➤ Place early production with key costumers
➤ Identify lead users				
➤ Identify competitive products				
Design				
➤ Study feasibility of product concepts	➤ Generate alternative architectures ➤ Define systems and interfaces	➤ Define part geometry ➤ Specify materials ➤ Specify tolerances	➤ Reliability performance and life tests ➤ Get regulatory approval	➤ Evaluate early production output
➤ Develop industrial design concepts	➤ Refine industrial design	➤ Industrial design control	➤ Implement design changes	
➤ Build and test experimental prototypes				
Manufacturing				
➤ Estimate manufacturing cost	➤ Identify suppliers ➤ Make/buy study	➤ Define processes ➤ Design tooling	➤ Begin supplier ramp-up ➤ Refine mfg. processes	➤ Begin operation of production system
➤ Assess production feasibility	➤ Define final assembly scheme	➤ Begin tooling procurement		

Manufacturing is not separate from the design and marketing aspect. This too is iterative with both design and marketing throughout the product development process. In the initial phase, manufacturing is important for concept development and design. A manufacturing cost estimate

is vital to determine the financial viability of the concepts, which is a make/break parameter for concept selection. The manufacturing process is also important when identifying the concept risk, for instance with respect to supplier options and tolerance requirements.

2.1.2 Concept development

Based on what is shown in Table 1, it would be fair to assume that most market products are not developed by one person working alone. A single person rarely has sufficient knowledge and experience with the various disciplines of engineering, manufacturing and marketing to lift an idea to a selling market product. For the same reason it would be unfeasible to expect a master thesis to address the complete development of a new wave energy utilization unit. This document is therefore limited to the concept development process shown in Figure 1. The concept development process is based on the expertise of Robert Q. Riley Enterprises, see reference (Robert Q. Riley Enterprises, 2016).

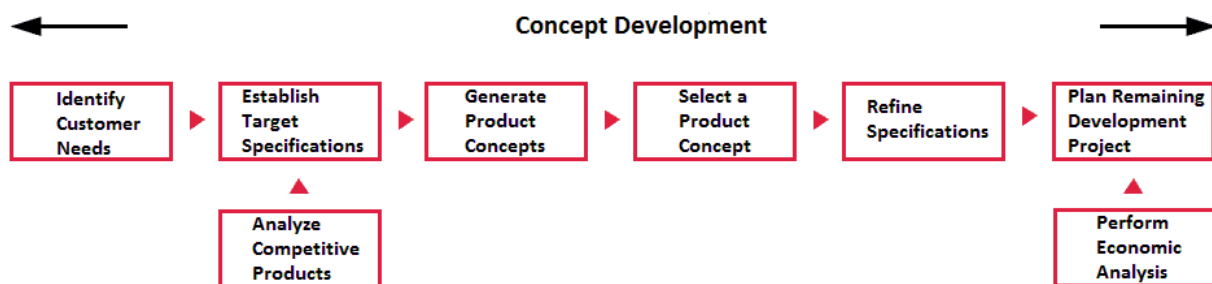

Figure 1. Concept development process

Identify customer needs

Post process of identifying and categorizing stakeholders, the customer's needs can be identified by asking the right questions. Note that the customer may not be aware of what (s)he wants from the product, so the researchers must also identify the hidden needs. The customer's needs and expectations normally falls in the categories of costs, size, robustness and service life, weight, appearance, etc.

Establish target specifications

The rule of thumb for developing a new product is that it must be either more efficient, easier to use or cheaper to make than competitive products already available on the market. Therefore, engineers establish the product's target specifications based on competitive products, the customer needs from market research and input from other stakeholders. However, there is a consensus among product developers that no one knows what the product will be like until it is completed. This is because the target specifications are established through an iterative scoping process throughout the project.

Analyse competitive products

It is standard practice while developing a new product to analyse the current or related products, also known as *benchmarking*. The current products acts like a frame of reference while establishing the product's target specifications. The analysis also enables the engineers to form a base from which the product is developed. This way the developers do not have to start from

Development of a Wave-Driven Pump for Energy Production

nothing, and can save resources more wisely spent otherwise. This is also the reason that so many products share significant resemblance, even to the point of intellectual property (IP) infringement.

Generate product concepts

The desired specifications of a product usually comprise opposing properties. For instance, safety or risk reduction counteracts costs and simplicity, and an acceptable balance must be identified. The product's properties can also be incompatible with one another. For instance, the engineers desire to develop an *oscillating water column* (OWC) unit close a local community, while the local community (stakeholder) does not accept the affiliated noise production. It is for these reasons that engineers normally develop multiple technically feasible concepts as part of a method of attaining a product that best meet the target specifications. Industrial designers develop renderings to show styling and layout, while engineers develop preliminary concepts and only after filtering out the best concept(s) are models or prototypes developed.

Select a product concept

The concepts are developed in sufficient detail so that their properties are measurable. After which, the concepts are compared to one another so that a single concept can be chosen based on scientific data. The concept selection group normally comprises the concept developers, along with company executives, but key customers and other stakeholders may also be valued for their input.

Refine specifications

With a product concept selected for further development, engineers can go into closer detail. Detailed engineering increases the accuracy of the estimate of the product's sales price and other attributes. Detailed engineering may also clarify some uncertainty the stakeholders may have had regarding specific details during concept selection.

The stakeholders renewed understanding of the concept can improve the project's credibility. On the other hand, the new information can also prove the concept unfeasible or incompatible with the customers' expectations. In which case the concepts must be adapted to the new scope or a different concept must be chosen.

Perform economic analysis

A cost estimate of the development- and production expenses lay the foundation for determining a sales price of the end product. Also with the cost estimate in place, a follow-up round of marketing research can give feedback from potential customers to support the decision of determining the sales price. It is at this stage, the estimate is conducted and the results utilized to develop an economic model of the product.

Plan the remaining development project

This is the final stage of the concept development process. The project team prepares a detailed development plan including an activities list, overview of resource requirements and expenses, and a product development schedule.

2.1.3 From development process to thesis

The concept development process, shown in Figure 1 and examined in the previous section, functions as the basis of the outline for this thesis. The first chapter expresses the general need for an efficient source of renewable energy and method for producing drinking water, and constitute as the “Identify Customer Needs” phase. Even though in truth, the chapter identifies the consumer’s needs, not the customers. The customers would typically be governments, farming corporations, foreign-aid organizations, etc. Nevertheless, a clear need is established.

This chapter addresses the phases “Establish Target Specifications” and “Analyse Competitive Products”. The following chapter partake in establishing the target specifications and also initializes the phase “Generate Product Concepts”. Yet this phase is mainly covered in the fourth chapter, along with the “Select a Product Concept” phase.

The phase “Refine Specifications” include establishing the modes of operation for the pump and is covered in chapter five and six, in addition to building and testing a prototype of the selected concept, covered in chapter seven. Chapter six also covers the “Perform Economic Analysis” phase, but is limited to examining a potential efficiency of the pump concept. Finally, the “Further Works” and “Conclusion” section constitute the “Plan Remaining Development Project” phase, covered in chapter eight.

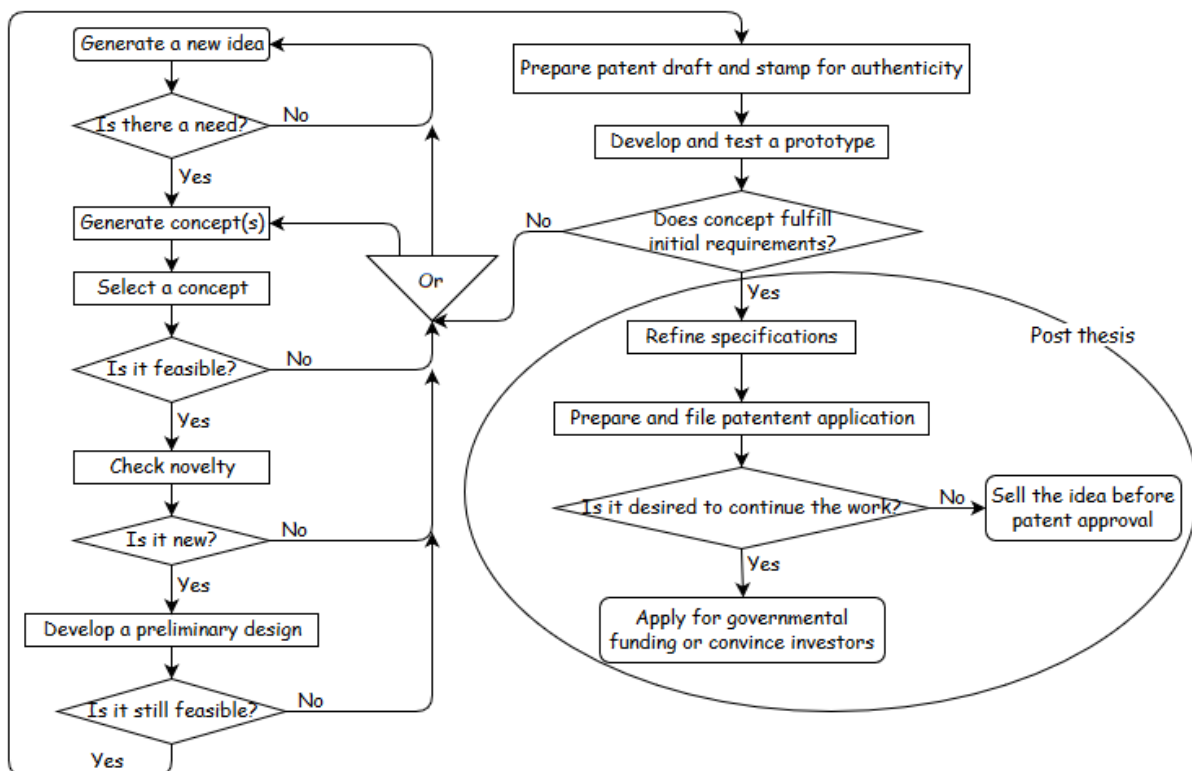

Figure 2. Flow chart of the development process as part of this thesis

Development of a Wave-Driven Pump for Energy Production

This thesis does not, however, just cover the development of a new product, but an invention. The development process must therefore be adapted appropriately. A flow chart of the development process that started with an idea is shown in Figure 2.

The flow chart may function as a baseline work process suited for many individuals (different process for companies) with an invention with which they wish to succeed in developing. However, the flow chart first and foremost explain the work process of this thesis. The part reserved for post-thesis work is also encircled.

2.2 INTELLECTUAL PROPERTY

To take advantage of the motion of ocean waves as a source for generating energy is not a new idea. Nor is it a new idea to produce clean water by evaporating seawater. The idea of using an elongating member to follow the motion of the waves to displace an internal fluid and thus generating hydraulic or electric energy is, on the other hand, apparently a new idea. See chapter three for details on the idea. Assuming that the idea is new brings on the science of intellectual property.

“Intellectual property refers to creations of the mind, such as inventions; literary and artistic works; designs; and symbols, names and images used in commerce.” (WIPO, 2016)

IP can be separated into two categories; *industrial property* and *copyright*. The latter covers artistic and literary work like songs, novels, poems, photographs and motion pictures. Whereas industrial property covers intangible property such as industrial designs, trademarks, trade secrets and patents. IP protects the owner by law to earn recognition for the idea or creation, and enables the creator(s) or inventor(s) to work with the product and earn financial benefit without the risk of theft.

IP protection is not necessarily a permanent protection, but may only be valid for a finite amount of time depending on the property type. For instance, industrial design protection is normally valid for a duration of five years, with a possibility for two times five years renewal. A patent gives the owner an exclusive right for twenty years while a trademark has an unlimited duration.

IP protection is one way of protecting a creation, but it is not the only way, and may not even be the best way to ensure that the creation remain a property of the creator. Another way of protecting ones property is by keeping the solution a secret. This is not uncommon concerning recipes. The recipe for Coke has not been unveiled since it was invented in 1886 and thus remained exclusively within the Coca-Cola company (The Coca-Cola Company, 2016). However, for inventors it is normal practise to apply for a patent protection on the invention to ensure its security during development and to obtain exclusive rights to produce and distribute for a finite amount of time.

2.2.1 Patent

A patent protects a specific solution to a technical problem (Patentstyret, 2015). A specific solution refers to a product or process that generally provides a new way of doing something, also known as an invention. A patented invention gives the owner an exclusive right to produce and distribute the related product for financial gain, for a finite amount of time. The patent is

normally valid for twenty years, from the date of submittal, once the patent application has been approved (Kolsofszki, 2015). In order to obtain an approved patent, the invention must satisfy the following conditions.

- The invention must have a practical use
- The invention must have absolute novelty worldwide
- The invention must have sufficient inventive step

A patent is only valid in the country or regional area to which the patent has been submitted for approval. A Norwegian national patent application would only be valid within Norway. An example of regional patent application is the European Patent Convention (EPC). Currently no patent system involves all the countries in the world. The Patent Cooperation Treaty (PCT), however, is the largest and considered the international patent system, and comprises 148 contracting states. These states are highlighted in Figure 3 below. Applying for an international patent counts as applying for a national patent in all of the contracting states, but the applicant pays only one set of fees.

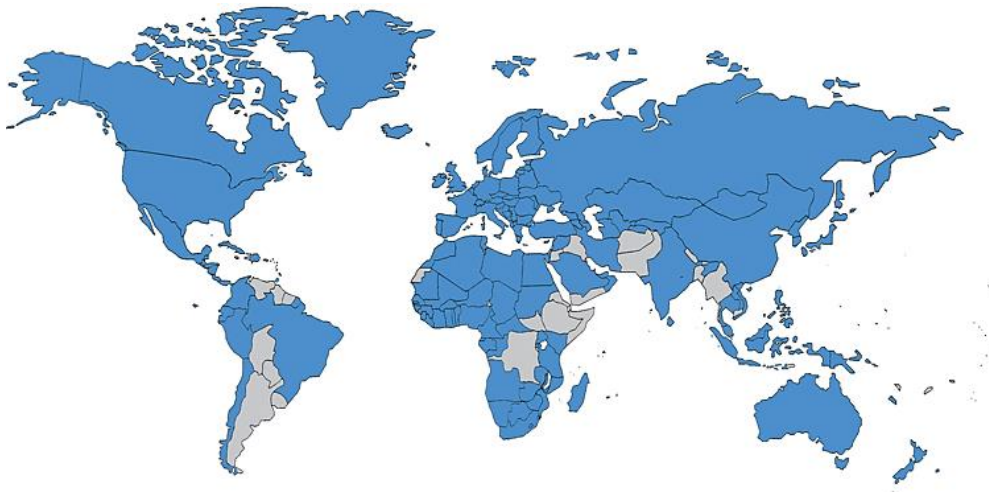

Figure 3. Contracting states of the Patent Cooperation Treaty marked in blue (WIPO, 2015)

An approved patent within the PCT is not valid in outside countries, such as Argentina and Pakistan. That means other parties may legally produce and sell products in these countries that would otherwise infringe with your patent within the PCT. If the applicant deems it beneficial to have a working patent for a specific country outside the PCT, then the applicant may file a separate national patent for that particular country.

To apply for a regional or international patent, as opposed to a national patent application, means that a broader range of existing patents may infringe with the applicants patent claims. One of the main drivers for having a broader patent application is the market potential of the product. Consider the conceptual idea examined in this paper as an example.

Norway has both a strong supply of clean water and electric energy from renewable energy sources. In fact, 98 per cent of Norway's energy supply comes from renewable sources, where the main source is hydropower plants (Norwegian ministry of oil and energy, 2014). In contrast to the Norwegian market, the invention has a strong worldwide market potential. Many states,

suffer clean water deficiency and other countries have a diminishing source of supply. There are also many countries aiming to reach new green-energy goals. Therefore, it would be unwise to limit the patent(s), affiliated with this concept, to a national application.

Not everything is patentable, and what is considered patentable varies among countries and patent systems. The EPC, for example, does not define the term invention, but rather expresses it as a product with a technical character. However, the EPC excludes computer programs and business methods as patentable. Comparably, the USA has no specific exclusion to what is patentable as long as it is a useful process, composition, machine or method of manufacture (WIPO, 2015). Yet, in many countries, it is not possible to patent scientific theories, commercial methods, natural discoveries¹, medical treatment methods or computer programs (Kolsofszki, 2015).

Prior to filing a patent application, the inventor or applicant should invest a decent amount of time to figure out where it would be beneficial to apply for patent, if it is patentable, or if there are any conflicting patents or products in the particular region.

2.2.2 How to write a patent

Patenting is a complicated field of expertise where a small mistake may cause a major complication. Without sufficient experience concerning the application process and the actual patent writing it is recommended to involve a patenting agency (Patentstyret, 2016). Still, writing the initial draft may prove beneficial for both parties. It may aid the patent engineer to understand what the invention concern. This, in turn, may reduce the engineer's working hours and thus save the inventor from an unnecessary monetary expense.

Writing the specific content of a patent may vary with language and the intended application. For instance, a direct translation from a national patent to an international patent may not be sufficient, or even correct. Yet, the content matter is generally consistent and normally comprises the following sections:

- Title
- Abstract
- Technical field of invention
- Prior art
- Background for invention
- Detailed description
- Drawings
- Claims

The *title* of the invention is the header of the first page of the patent document. The title should be short and give a certain indication as to what the invention comprehend and to what technical field of expertise it belong.

The *abstract* should begin on a separate page and be no longer than 150 words. Knowing the title, the reader should be sure of the specification of the invention after reading the abstract.

¹ Natural discoveries cover laws of nature, discoveries of animal and plant species, natural substances and naturally occurring phenomena.

The abstract should, in short, specify what is new about the particular invention, but be limited to a single paragraph (USPTO, 2014).

The description of the *technical field of the invention* does not necessarily have to be a separate section. However, the reader must be able to be sure of what technical field the invention belong to, and if relevant, what other uses the invention potentially possess. The section does not have to be long, but may consist of a few lines.

Inventions filed today are usually built upon or comprising of known technology. The known technology must be referred to in the section of *prior art*. In addition, if applicable, the section should refer to other patents that may serve a similar function or are particularly relatable to the invention. In which case, the reader should be able to find these patents with ease. The section further aids the reader to understand the subject matter and to distinguish what's new from what's known.

The general understanding is that every patent starts with an invention, and every invention starts with an idea. Often the idea started with the need for a solution to a specific problem. That very problem and how the idea came to be makes the section; *background of the invention*.

How the invention works, how it is used and what it comprises is covered in full in the *detailed description* section. The section should be concise and suffice to the intent that an average skilled person in the relevant technical field is able to recreate and use the invention with moderate effort. It is usually necessary to use at least one drawing to eliminate any uncertainties as to how the invention works or is composed. Every element that makes out the function of the invention should be mentioned in the description, preferably by both name and number. After reading this section, the reader should completely understand the invention and be able to separate the new from the known.

Most patent applications include *drawings*, and serve the function of aiding the reader to understand the invention along with the detailed description. The applicant must refrain from using any colours in the drawing, as it restricted to be composed of black and white. The drawing must include every element that is mentioned in the patent claims.

2.3 HYDROSTATIC PRESSURE

The pressure effect that is a function of the column height (h) of a fluid, the density (ρ) of said fluid and the gravitational acceleration constant (g) refers to as hydrostatic pressure. When working with equipment either submerged in a liquid, or containing a liquid, the hydrostatic pressure should be addressed.

The hydrostatic pressure is exerted normal to every surface immersed in the fluid, as illustrated in Figure 4. The illustration is a simplified visual of hydrostatic pressure and shows a cube fully submerged in a liquid with an above pressure exerted on the liquid's free surface.

A liquid is commonly regarded as an incompressible or nearly incompressible fluid, and the density of the liquid may thus be considered constant. Still, this may not always be an appropriate assumption. In the oil and gas industry, subsea equipment is placed at depths exceeding 2000 metres below mean sea level (MSL). At such depths, both decreasing

temperature and increasing pressure causes the density of the seawater to increase with depth. The density of the liquids affiliated with this project, however, is considered constant.

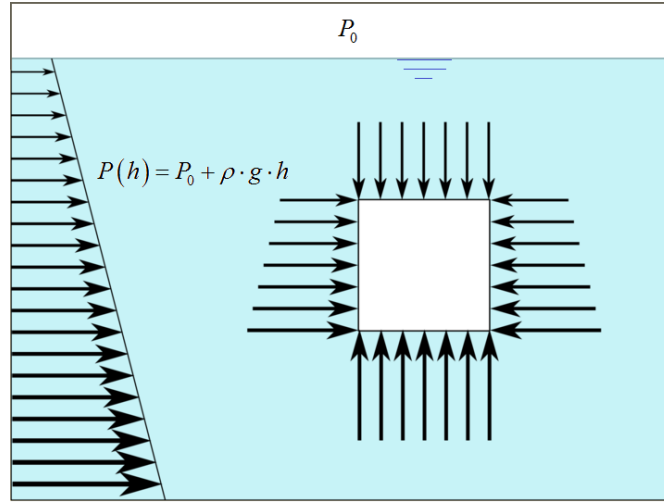

Figure 4. Illustration of hydrostatic pressure on a submerged cube (Wikipedia, 2016)

2.3.1 Buoyancy

Building on the subject of hydrostatic pressure, buoyancy has a key purpose on the developed system of this thesis. The buoyancy force is one of the primary acting forces that drives the pump of the student's concept. For that reason, it is beneficial to understand what buoyancy is and how it can be used advantageously and in a simple manner.

To understand the buoyancy effect, return to Figure 4. The upward pressure acting on the bottom surface of the submerged cube is larger than the downward pressure acting on the top surface, due to the different submerged depths of the two surfaces. The buoyancy force for the cube may be expressed as in Eq. (2.1).

$$F = P_{bottom} \cdot A_{bottom} - P_{top} \cdot A_{top} \quad (2.1)$$

For simplicity, the surface area is the same for all of the cube's six surfaces. In addition, the equation may be expanded to express that the pressure acting on the surfaces is hydrostatic pressure as in Eq. (2.2).

$$F = (\rho_{fluid} \cdot g \cdot h_{bottom} - \rho_{fluid} \cdot g \cdot h_{top}) \cdot A \quad (2.2)$$

While assuming a constant fluid density, the only varying parameter, relating the top and bottom surface of the cube, is the fluid column height. The buoyancy force can thus be expressed as in Eq. (2.3)

$$F = \rho_{fluid} \cdot g \cdot \Delta h \cdot A \quad (2.3)$$

The volume of the cube, shown in Figure 4, is expressed as its surface area multiplied with the height of the cube, see Eq. (2.4).

$$F = \rho_{fluid} \cdot g \cdot V_{cube} = m_{displaced\ fluid} \cdot g \quad (2.4)$$

Therefore, it may be shown that the buoyancy force acting on a submerged object is equal to the weight of the fluid displaced by the object as in Eq. (2.5).

$$F = W_{\text{displaced fluid}} \quad (2.5)$$

When working with objects of different geometries, it may prove quite difficult to estimate the various pressures acting on all the surfaces. Knowing that the buoyancy force is equal to the weight of the displaced fluid has proven a great asset to engineers, and is known as Archimedes' principle (Elert, 2016).

2.4 WAVES AND WAVE ENERGY

The heat from the sun warms up the earth's various surfaces, causing pressure variations across the landscape, which in turn creates wind. Created as the wind blows over the ocean surface, ocean waves can be construed as an indirect form of solar energy and utilized as a source of renewable electric energy.

The average energy intensity of the waves just below the surface is approximately five times the intensity of wind 20 metres above the sea surface, and 10 to 30 times that of solar energy. The ocean covers more than 70 per cent of the earth's surface and the estimated global energy potential from waves is 30,000 [TWh] every year (Fornbybar, 2016). This energy can be harnessed from every corner of the world and it would therefore seem logical to explore this field further. However, waves have a reputation of being a somewhat destructive force. Only by firmly understanding how waves occur and behave can one extract its energy potential to be an economical competitor in the global energy race.

2.4.1 Wind waves

There are numerous causes for ocean wave generation, such as earthquakes, gravitational pull and underwater volcanic activity. However, the primary cause of ocean waves is by wind blowing over the sea surface, referred to as wind waves.

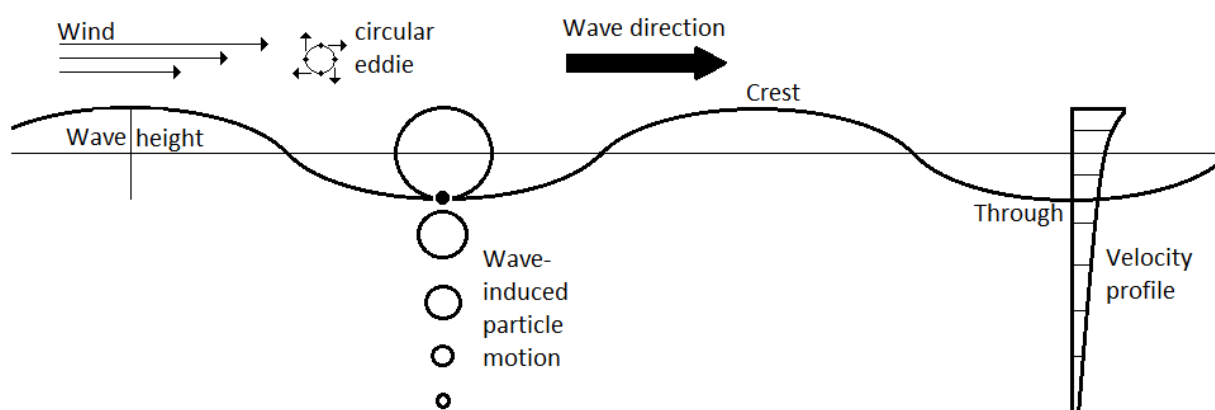

Figure 5. Illustration of waves generated by wind blowing across the ocean surface

Wind waves are primarily generated by wind blowing across the sea surface and energy is transferred from the wind to the water by the frictional force between the air particles and the water particles. The horizontal water particle velocity is reduced per layer with depth because of viscous shear forces, creating a velocity profile, as illustrated on the right of Figure 5. The

variation in flow velocity causes the fluid to spin, creating a circular motion. The result is waves with the same spin, but in opposite direction.

In addition to the spin of water particles below the MSL, there is spin of air particles above the MSL. The frictional force from air and water interaction is higher than the friction between air and air. Therefore, by each layer of air above the MSL, the wind velocity is slightly higher. This creates Eddy currents above the sea surface that pushes on the sea surface and thereby adding to the creation and shape of waves.

While working with waves we distinguish between local wind waves (local waves) and swell waves. Local waves are waves generated by wind in the local area. Whereas swell waves are waves created by wind from an area far away. In this distant weather system, the wind has blown in the same direction for an extended period. In addition, these waves have had a long distance over which they could develop to a stable system of waves, referred to as fully developed sea. This distance is known as *fetch length*, or simply ‘fetch’ for short. When local waves and swell waves operate in the same area they are most likely not travelling in the same direction in which case we do not have simple, two-dimensional, waves as illustrated in Figure 5, but rather a complex system of wave motion.

2.4.2 Linear waves

Waves are usually not simple and sinusoidal shaped, as illustrated in Figure 5. They come in random shapes and heights with larger crests than troughs, which at first glance may seem impossible to predict. Still, a good description of the ocean waves in an area can be obtained with mathematical models that estimate each contributing system of waves. The easiest method of describing waves is by first-order Airy wave theory, also known as *linear wave theory*.

Linear wave theory uses linearized boundary conditions and deep-water² simplification to describe waves as sinusoidal shaped, harmonic waves (Gudmestad, Linear wave theory, 2015). In this type of waves, the trough and crest have the same distance from the MSL and the wave profile is described as in Eq. (2.6).

$$\eta = \frac{H}{2} \sin(\omega t - kx) \quad (2.6)$$

This is the core theory used for description of ocean waves. However, this type of waves do not occur in reality. The closest type of waves to match this description is swell waves. Yet, a swell wave sea is the supposedly ideal environment for harnessing the wave energy with wave energy plants. This is also the case for the invention of concern in this document.

Wave velocity

While standing at the beach looking out across the sea, one may quickly get the sense that the ocean is coming towards you. However, it is not the ocean, but the waves that are coming towards you. This is perhaps most easily explained by comparing the sea with a rope. Imagine a person holding one end of a rope in a fixed position, while a second person is holding the other end of the rope and moving his/her hand up and down, quickly, and repeatedly. It is not

² In this particular field, deep water is defined as an area where the wavelength is less than two times the water depth.

the rope that moves forward, but the waves that propagate along the length of the rope. The velocity of such waves are defined in two ways, *phase velocity* and *group velocity*.

The time it takes a wave crest to reach the immediate position of its preceding wave crest is known as the wave period, T . The distance between these two wave crests is defined as the wavelength, L . The ratio between the wavelength and the wave period is the phase velocity, as described in Eq. (2.7).

$$c = \frac{L}{T} \quad (2.7)$$

In terms of angular frequency, ω the phase velocity is given as in Eq. (2.8).

$$c = \frac{\omega}{k} \quad (2.8)$$

Here, k , is the wave number and is given by Eq. (2.9).

$$k = \frac{2\pi}{L} \quad (2.9)$$

The velocity that the wave energy travels with is however not the phase velocity, but the group velocity, c_g . So what is the group velocity? Imagine you drive a boat in a sea of swell waves and try to converge the velocity of the boat to a magnitude at which you do not feel the effect of the waves. That is the group velocity, and it is the speed of a group of waves travelling in a given direction along the MSL (Krogstad & Arntsen, 2000). With linear, harmonic, deep-water waves, the ratio between the phase velocity and the group velocity is one half, as expressed in Eq. (2.10).

$$c_g = \frac{1}{2} c \quad (2.10)$$

Meanwhile, in very shallow water the phase velocity and group velocity are equal.

In addition to the velocity of the waves themselves, each individual water particle move in a circular motion. The particles in the wave zone and down to approximately half the wavelength from the MSL, orbit with a horizontal and vertical velocity component, as illustrated in Figure 5. The particle velocity components are the partial derivatives of the wave velocity potential, φ . For linear deep-water waves, Eq. (2.11) gives the horizontal velocity component.

$$u = \frac{\partial \varphi}{\partial x} = \frac{H \cdot k \cdot g}{2 \cdot \omega} e^{-kz} \sin(\omega t - kx) \quad (2.11)$$

Here, the z-axis originate in the MSL with positive direction down. This equation shows how the horizontal velocity component has an exponential decay with water depth, as shown in Figure 5.

Eq. (2.12) gives the vertical velocity component for linear deep-water waves.

$$w = \frac{\partial \varphi}{\partial z} = \frac{H \cdot k \cdot g}{2 \cdot \omega} e^{-kz} \cos(\omega t - kx) \quad (2.12)$$

The velocity components can be further derived to express the fluid-particle acceleration components. Attached in Appendix A is a review of linear wave theory formulas.

Wave energy

With the purpose of using waves as a source of renewable energy, larger waves mean more wave energy, which means more energy output. Therefore, it would be most beneficial if a wave energy plant could take advantage of stormy weather. However, in reality, this type of weather system has quite destructive properties and low predictability. The most reliable wave system is a pure swell sea. These waves are by nature far smaller, but the energy potential is still significant, partially because they have a relatively large group velocity.

Ocean waves do not transport mass as much they transport energy, and they comprise two types of energy, potential energy and kinetic energy. The kinetic energy comes from the fluid particle motion in- and beneath the wave zone, as previously mentioned. The potential energy comes from the variation in the water level and the difference of hydrostatic pressure under the wave crest and trough. In linear wave theory, the sum of the potential energy and the kinetic energy in a wave is given by Eq. (2.13).

$$E = \frac{1}{8} \rho g H^2 \quad (2.13)$$

Here, E is the average energy density of the wave per horizontal unit area.

Eq. (2.13) uses the wave height squared. The exponential effect of increasing wave energy by increased wave height can be seen in the graph of Figure 6. The seawater density used to create the curve in Figure 6 is set to 1025 [kg/m³].

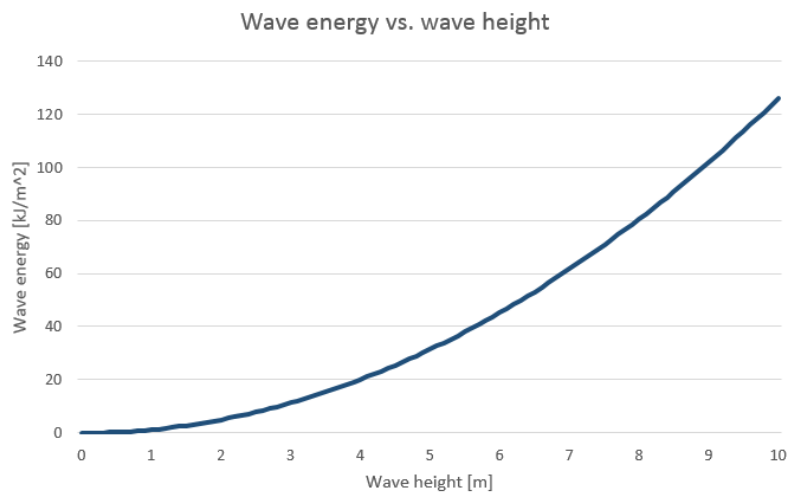

Figure 6. Increasing wave energy with wave height

The graph shows how much energy on average there is in a particular wave, given the wave height, but how much of this energy that can be transformed into consumer friendly electric energy depends on the functionality of the wave energy plant.

2.4.3 Irregular waves

The sea state does usually not consist of single-frequency waves, as shown in Figure 5. A pure swell sea is relatively rare, depending on geographical area and season. The sea state usually consists of irregular waves with different shape, height, phase velocity and angle of attack. This

makes it all the more difficult for engineers to estimate the magnitude of wave forces that a marine structure or vessel is exposed to in a given sea state.

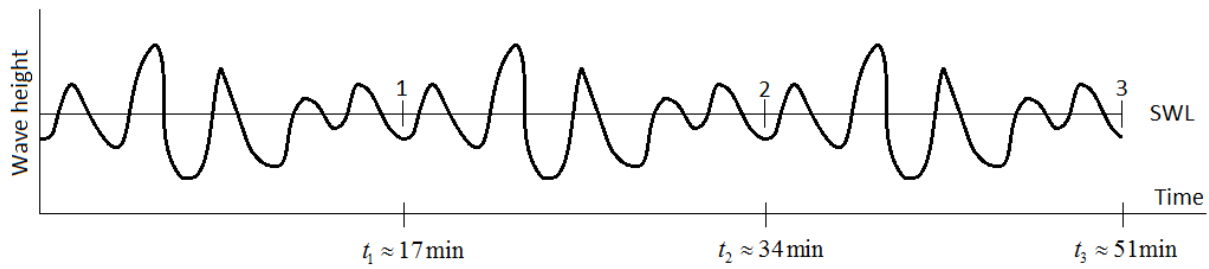

Figure 7. Series of set of regular waves

A standard method for describing a sea of irregular waves is by firstly ignoring the angle of which the waves approach. The height of every wave is then measured. This is normally done by measuring the elevation of the sea every two seconds for 17 minutes and four seconds, resulting in 2048 measurements (Næser, 2012). These measurements are then used to describe the height between the wave crest and the following trough, but only for the waves where the crests reaches the still water level (SWL). The waves that do not have the crests reaching above the SWL are left out of consideration.

The method is sufficiently accurate so that the system of irregular waves can be expressed not as a series of single-frequency waves, but as a series of a set of regular waves, as illustrated in Figure 7. For such a group of waves, the frequency of the wave heights that occur are expressed in a statistical distribution of wave height, see Figure 8.

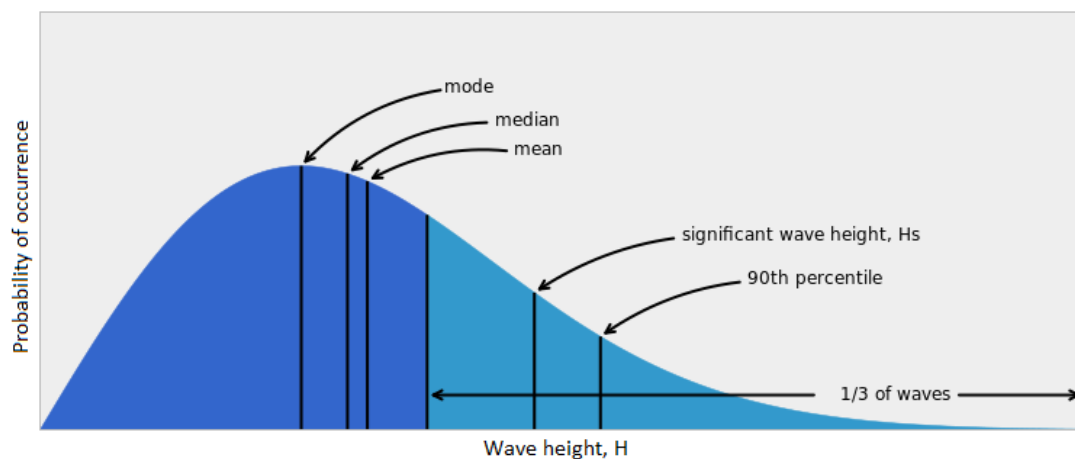

Figure 8. Wave height probability distribution (Wikipedia, 2015)

There are two types of wave heights that are of particular interest when designing marine structures, planning marine operations, etc. These two are the significant wave height, H_s and the maximum wave height, H_{max} . The latter refers to as the highest wave in a given wave group. For a three-hour storm, the assumed maximum wave height may follow Eq. (2.14).

$$H_{max} = 1.86H_s \quad (2.14)$$

The previous definition, or rule of thumb, of the significant wave height is the average of the 1/3 highest portion of waves in the wave group. Back in the day, this would be the wave height as defined by a “trained observer” looking at the sea surface.

A wave energy plant should be able to make use of the higher waves, as these transport more energy, but also utilize the waves around the mode height, as seen in Figure 8, as these occur at higher frequency. Still, there have been cases where projects have been wrecked by storm shortly after, and even prior to completion. Therefore, the wave energy plant must not only be able to harness the energy of the waves, but also be able to endure them. The Norwegian Petroleum Safety Authority requires all sea structures to be designed to sustain a combination of 100-year wave and wind plus 10-year current (Gudmestad, Wave loads, 2015). In regards to waves, a 100-year wave means a wave with one per cent chance of being exceeded every year, or in other words, a wave height that would be expected to occur once every century on average.

Wave spectrum

Instead of describing a group of waves by its wave height in a statistical distribution, as in Figure 8, it has become normal practice to describe the sea state by its energy distribution. This is done with a *wave energy spectrum*, simply known as a wave spectrum. The wave spectrum uses the energy equation from linear wave theory combined with the wave height distribution to give a description of the energy in a wave group. There are various types of wave spectra suited for different sea states depending on the oceanic region. For instance, the wave spectrum that is best suited for the North Atlantic is the JONSWAP spectrum. In the North Sea, the best-suited wave spectrum is the Torsethaugen spectrum. Most ocean-wave spectra, however, follow the standard mathematical formulation of Eq. (2.15) (Tchet, 2005).

$$S(\omega) = \frac{\alpha}{\omega^5} e^{-\beta} \quad (2.15)$$

Examples of such ocean-wave energy spectra are the spectra shown in Figure 9.

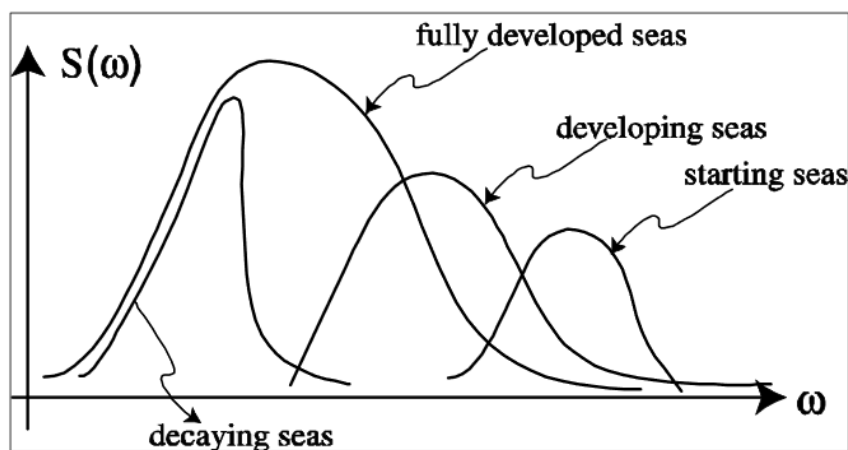

Figure 9. Examples of wave energy spectra for seas at various stages (Tchet, 2005)

The area under the curve is known as the zeroth order moment, m_0 , and is included in the modern definition of the significant wave height, see Eq. (2.16).

$$H_s = 4\sqrt{m_0} \quad (2.16)$$

If an offshore vessel has its Eigen- (natural) frequency of motion in or close to the frequency of the energy peak of the spectrum of the sea state in which the vessel is in, the vessel will experience violent motions due to resonance with the sea. For floating drilling and/or production vessels or floating installation vessels, resonant motion is in no operational scenario acceptable. Yet for a wave energy plant, resonant motion can be the very phenomenon that can make small-sized swell waves to a commercially competitive energy source.

Wave energy globally

Waves are generated by wind, and wind is created by solar energy in the form of heat. This means, as mentioned earlier, that wave energy can be viewed as an indirect form of solar energy. This also means that the geographical areas with large temperature variations experience more wind and thus larger waves. Therefore, areas with significant temperature variations also have more wave energy hitting the coastline compared to areas with a stable climate. This can be graphically displayed in a *global energy distribution chart*. These are developed through a long period of measuring the wave height at various locations. Such a chart is displayed in Figure 10.

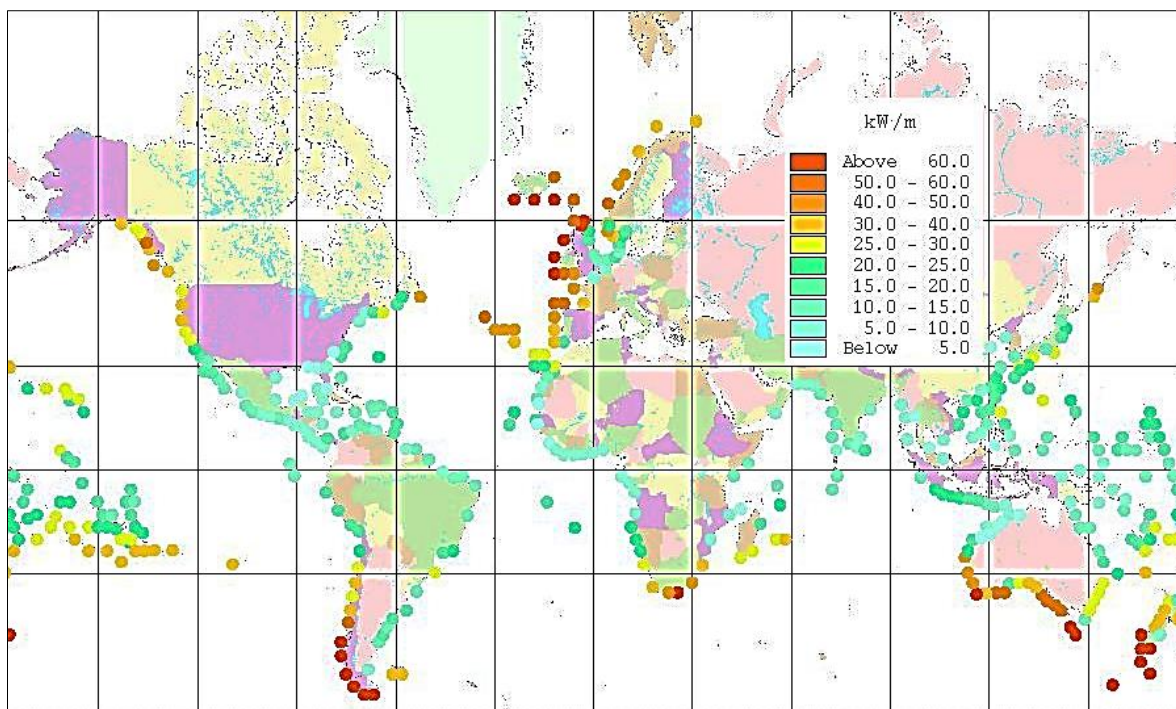

Figure 10. Global wave energy chart (Lazinski, 2010)

The largest waves and thus most wave energy are particularly located far south or far north. These areas experience large temperature variations through seasonal changes. This also means that these areas in general have augmented irregular waves and stormy weather. Meaning there is more energy to utilize, but also far more difficult to design viable wave energy plants for these areas. In contrast, areas with less wave energy, typically located in and about the equator, experience less storms and more swell. This type of weather system is ideal if the energy utilization suffice.

2.5 TIDE

Children often find it fun to run and jump up and down the floating dock at the public marina. If the child is particularly curious as well, then (s)he might also wonder why the dock is afloat. One of the main reasons is to have the dock naturally in station with the floating boats in tide. So what is tide? Assumably, tide is best known as the change in the mean sea level, caused by the moon's gravitation, but there is more to it. Ocean tide has numerous influencing factors. The three main factors are the gravitational pull from the moon and sun, and the earth's rotation. Variation in the effect of gravitational pull across the globe causes the ocean to bulge. This causes the ocean to envelope the earth in a somewhat elliptic shape, as shown exaggerated in Figure 11.

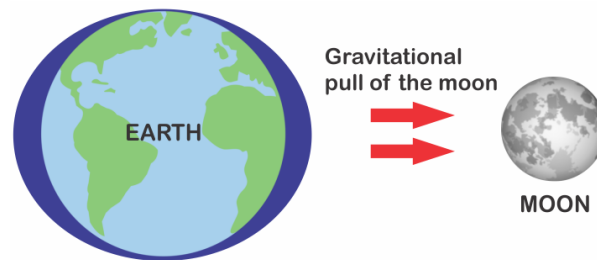

Figure 11. Elliptic shaped ocean caused by gravitational pull (MYCAPE, 2016)

The earth's rotation about its own axis causes oceanic areas to experience the sea level variation differently. Numerous additional influencing factors also causes tide to behave differently depending on the oceanic region, such as the rotation of the moon and its orbit, the earth's orbit around the sun, ocean- depth and coverage and more. Thus, astronomical calculations do not suffice in accuracy of determining the tidal effect for a particular area. The sea level of the area of interest is therefore measured in a manner that excludes the effect of waves and charted in a *tide prediction table*. The highest tides occur when the sun and moon align, resulting in an added gravitational pull. Currently measured, the highest tides in the world reaches 16.3 metres, in the Bay of Fundy, Canada (NOAA, 2014).

The Norwegian Mapping Authority is responsible for the calculations of tide prediction tables for the Norwegian coast. Published by Kartverket (source: (Kartverket, 2016)), a sample of the tide prediction table is attached in Appendix B. The sample concerns the coast of Stavanger, and comprises a draft of the most important (measured) tide values for the area and a prediction of tide throughout 2016.

In the oil and gas industry, the highest astronomical tide (HAT) is important to elevation and air gap design of various fixed and floating platforms. Tidal effects are also critical to consider when designing a concept for wave energy utilization.

2.6 WAVE ENERGY PLANTS

The first patent for a wave power plant came in 1799. Still, it was not until the oil crisis of 1973 that wave energy was given serious consideration as a contributing source of energy (Falcão, 2009). Yet there has been no significant breakthrough in the field, at least not significant enough to make waves a competitive energy source. One of the major limiting factors in the development of wave energy plants is the fact there are numerous alternatives to wave energy

that are more reliable and cheaper. There are projections that wave energy will be a competitive energy source as soon as 2020, but wave energy is still considered a high-risk investment. So why should governments and companies invest in wave energy, and what makes these types of projects high risk?

Advantages

- There is a large energy potential
- Wave energy is a renewable energy source
- A potentially suitable energy source for small island/fishing communities as well as for larger cities
- Wave energy plants have low operating costs
- Waves are a worldwide-existing energy source
- Waves are a continuous energy source throughout all seasons, even though its significance in contribution may vary

Disadvantages

- Wave energy plants have high developments costs
- The sea can be unpredictable and is a very corrosive environment
- Wave energy plants are vulnerable to storm
- There can be a high level of noise from turbines, disturbing local communities and wildlife
- Wave energy plants may influence the ocean's natural current and disturb marine life

Currently, the most active communities participating in the field of developing wave energy plants are found in Great Britain (Scotland in particular), Sweden, Denmark, USA and Australia. Norway's contribution to the field has remained primarily academic. Because, even though the Norwegian coastline has a large wave energy potential, the country's energy consumption is already 98 per cent based on renewable energy. There is also an ongoing trend to invest in wind energy, rather than wave energy.

There are numerous concepts for how to utilize the motion and power of the waves, grouped under the term 'Wave Energy Converter' (WEC). Most of these have had little success, while some concepts have been connected successfully to a national grid. The most well-known WEC concepts and most successful projects are examined in this section.

2.6.1 Oscillating water column

The OWC is a well-proven concept where the unit can be stationed on land, in shallow water or as a floating ship-shaped unit. This WEC works by having a partially closed structure with an opening below the wave zone, as illustrated in Figure 12. As waves approach the WEC, there is a variation of water volume inside the unit. The oscillating column of water creates pressure variations, causing the air inside the unit to be compressed and exerted out, via a turbine, when the water column rises. When the water column subsides, the dry section inside the unit becomes a low-pressure system and thus air returns via the same turbine. The turbine used for this concept is a Wells turbine. Named after its inventor, Allan Wells, this turbine's defining characteristic is that it has the same efficiency, regardless of airflow direction.

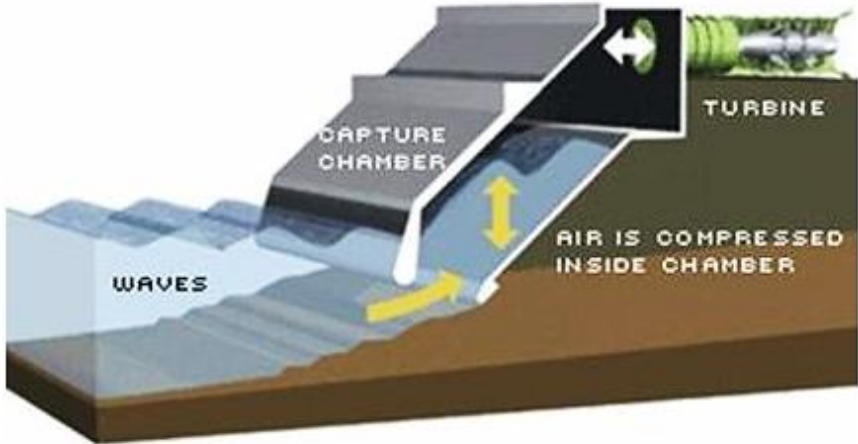

Figure 12. Oscillating Water Column (Johnson & Olson, 2010)

This concept was installed as an onshore unit on an island south of Scotland, called Islay, and was the first WEC to be installed on the national grid in the UK. The advantages with this concept are that the rotating parts are not submerged. In addition, since the unit is onshore the accessibility for maintenance is good and it can easily be connected to the grid. However, under operating conditions, this unit produces a high level of noise that disturbs the local population and wildlife.

2.6.2 Buoy

The buoy concept is generally two-fold, where a floating buoy is partially submerged (floating) or fully submerged. The buoys are anchored to the sea floor in both cases. The floating buoy utilizes the buoyancy effect in combination with the varying sea level, that is the difference between the wave crest and trough, to create an oscillating motion on the buoy to drive a pump or generator.

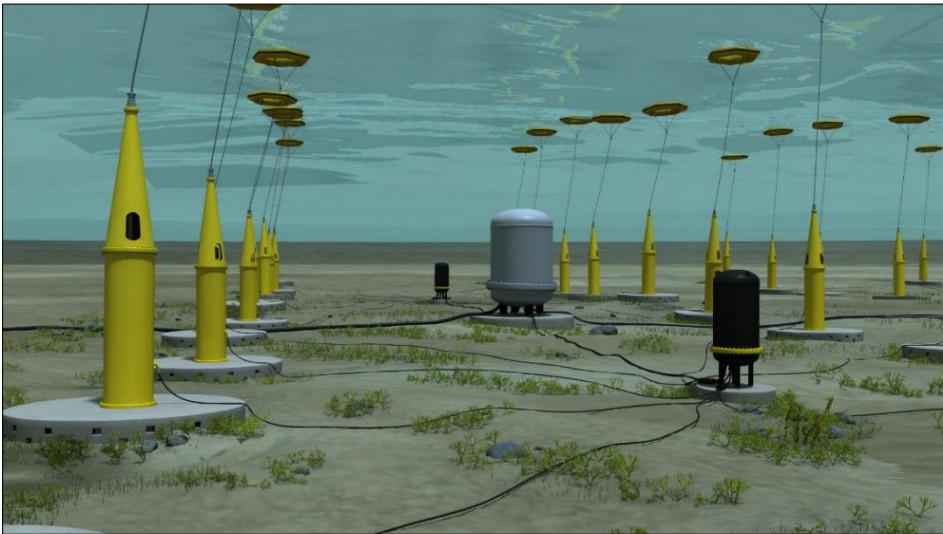

Figure 13. Illustration of the wave power plant outside Sotenäs (Seabased, 2015)

Just before the start of 2016, Seabased AB developed the largest full-scale wave power plant in the world using the floating buoy concept, see Figure 13. Located outside Sotenäs municipality in Sweden, the wave power plant cover an area of 0.8 [km²] and is the first multiple-unit power plant, with a total of 420 floating buoys. The WEC unit uses the buoy's heave motion as driving force for a vertically-oriented subsea electric power generator. Once the park is fully operational, it will deliver an energy output of 10[MW] (Williams, 2016).

Carnegie Wave Energy completed in 2015 the installation of Australia's first grid-connected wave power plant, see Figure 14. This system makes use of the submerged buoy concept. The submerged buoy utilizes the varying hydrostatic pressure under the waves and the circular motion of the water particles just below the wave zone. This creates an oscillating motion on the buoy that is the driving mechanism to transport pressurised seawater through a turbine that produces electric energy (Carnegie, 2015). This system is under the wave zone even during storm and thus said to be protected from the affiliated forces.

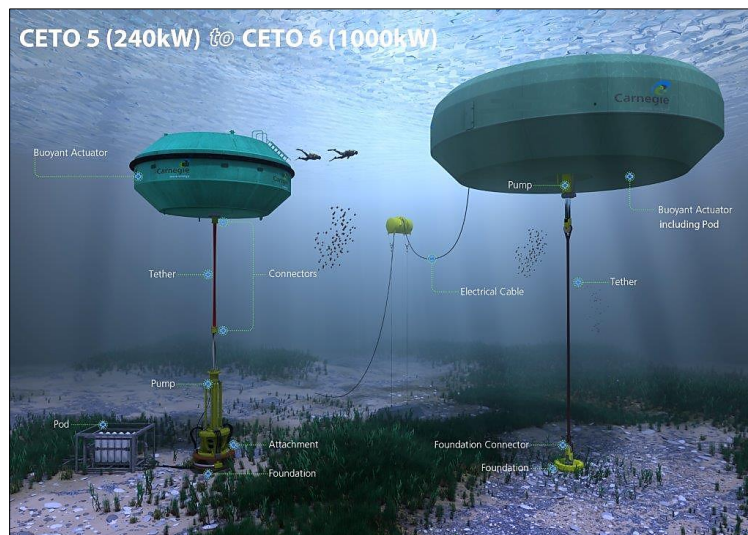

Figure 14. Carnegie Wave Energy submerged buoy concept CETO5 and CETO 6 (Gough, 2015)

2.6.3 Overtopping

The concept of overtopping is to have a unit that allows large volumes of green sea³ to topple over, into a duct or drain. This can be done by having a wide spread dam-like wall in deeper water that forces waves to topple over the wall and accumulate in a duct that directs the flow through a turbine to produce energy.

Another concept that uses overtopping is the *Wave Dragon*, illustrated in Figure 15. This is a large floating unit, which is shaped to promote green sea and temporary store it in a reservoir. Once a set level of water has accumulated, the water is released from the reservoir and back into the sea via a turbine, thus producing electric energy.

³ Green sea refers to the water that splashes onto the deck of a vessel from wave impact.

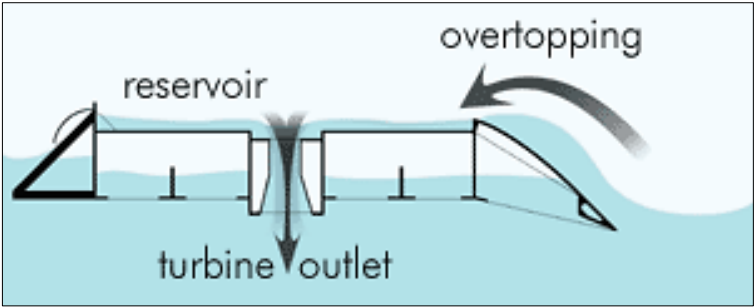

Figure 15. Wave dragon concept (Wave Dragon, 2005)

The Wave Dragon is very buoyant so that the water is stored sufficiently above the sea level to obtain enough pressure head. This method requires a turbine that is efficient at high volume flow rate, but low pressure-head. The Wave Dragon concept is simple but requires significant design effort to enable robust and efficient energy production.

2.6.4 Sea snake

The final concept summarized here is the sea snake concept and will mark the end of this chapter, to be followed by the examination of the student-developed concept. The sea snake is a slender system comprised of multiple tubular sections connected in series by rotary joints. This allows the WEC to follow the motion of the waves with little friction, and generates energy by utilizing the curving motion of the snake.

One of the most successful WEC projects is the Pelamis project. Located off the coast of Portugal, the project was completed in 2008 and initially comprised three Pelamis generators, producing an output of 2.25[MW] (Power-Technology, 2016).

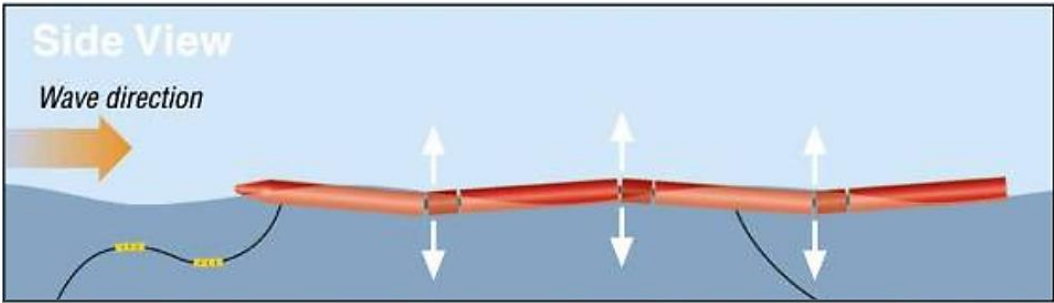

Figure 16. The Pelamis sea snake (Ocean Power Delivery LTD, 2013)

The Pelamis sea snake uses flexible joints between the tubular sections, see Figure 16, to absorb energy from the snake’s heave and sway motion. The absorbed energy drives pistons to circulate a fluid through hydraulic motors. The mechanical energy from the hydraulic motors produces electric energy.

Some major advantages with this concept is robustness, little on-site construction work and foreseeable energy production with minimal environmental impact, apart from the concern for wildlife being lodged in between the joints. On the downside, this WEC is quite vulnerable to corrosion.

CHAPTER 3 – THE CONCEPT

This chapter covers the student-developed concept for converting the energy of ocean waves. The pumping mechanism is explained in a stepwise manner and the chapter briefly discusses some benefits of the concept in relation to the concepts examined in the previous section.

3.1 CONCEPT NAME AND POTENTIAL TRADEMARK

The concept at whole is named AWACE Production. AWACE is an acronym pronounced by British-English ‘əˈweɪk’, otherwise phonetically written ‘awake’, and is the abbreviation of Autonomous Water And Clean Energy. Should the concept serve the purpose as a start-up company product then this name could function as the company name and trademark. The name emphasizes the idea that we, as a global society, need to “wake up” and realise that action must be taken in order to reduce pollution and global temperature increase. The name can also give the reader the impression that the people within the company has “awaken” and are working specifically to solve this issue, given that the reader is aware that the company is a renewable energy production company. Figure 17 shows a potential trademark logo for the theoretical company.



Figure 17. Potential AWACE Production logo

The logo shows the company name where the ‘w’ is written in the shape of three waves, to allude to the company’s connection with ocean waves. A frame connected into itself by two rings further encircles the name. The frame gives the reader more than the iconic ‘w-waves’ to use as a visual reference to the company, and also represents the concept of renewable energy in the style of “what goes around, comes around”.

3.2 CONCEPT DESCRIPTION

The concept at hand is the student’s proposal to partake in solving the issues of meeting the global demands of renewable energy and clean water production. The proposal consists of an ocean-wave energy converter comprising of a pump intended to transport fluid and/or to displace fluid to power hydraulic turbines for energy production. The initial intention for transporting fluid is to use the wave-driven pump as a continuous means of supplying a desalination plant with seawater.

One of the earliest drafts made to illustrate the concept is shown in Figure 18 and illustrates an offshore platform housing an ocean wave pump that transports seawater after the impact of a wave on a balloon-like unit, hereby referred to as balloon.

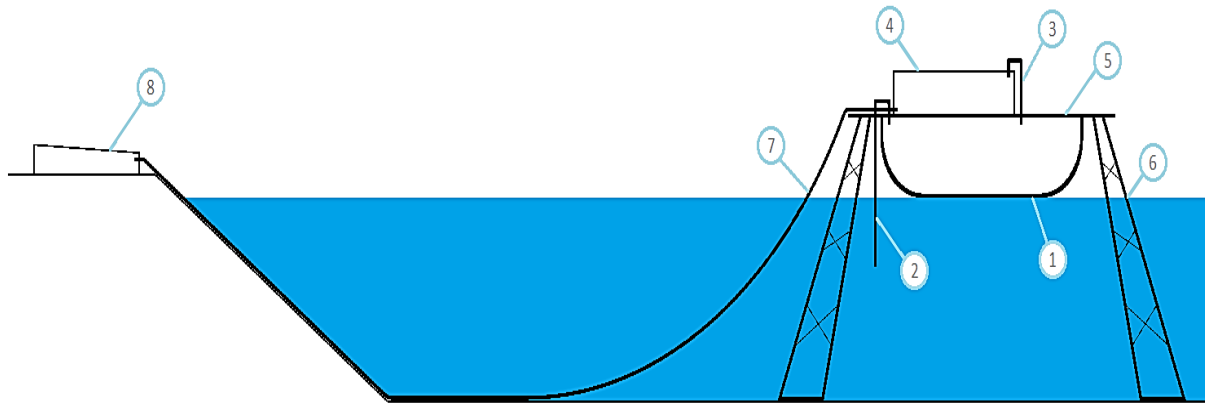

Figure 18. AWACE Production concept draft

When a wave hits the balloon (1), the balloon's volume compresses, thus forcing the water contained within through an outlet (3) and into a container (4). When the wave impact on the balloon subsides, the balloon returns to near its original volume by the weight of its remaining content and its own weight. This creates a low-pressure system within the balloon that allows seawater to be pushed through the inlet (2) and into the balloon. The cycle continues as long as there are waves of sufficient size.

The offshore wave energy converter unit, hereby be referred to as the AWACE unit, is in Figure 18 shown as a jacket platform. The jacket topside (5) supports the balloon hanging beneath and is installed on legs (6) that are anchored to the seafloor.

The fluid stored within the container is further transported through a pipe (7) to an onshore desalination plant (8). In the desalination plant the water is evaporated by heat. By an inclination in the roof-section of the desalination plant, the evaporated water relocates to a desired location and returns to a liquid state of fresh water as it cools down, leaving behind salt and other undesired matter in the desalination plant. In the event of washing out the content left behind in the desalination plant, more seawater can be accumulated within to be flushed out of the plant and back into the sea, thus removing the residual content.

The seawater can be evaporated by using sunlight that heats up the surfaces of the desalination plant. The water can also be artificially heated during the hours of little or no sun by electric energy produced at the platform. The electric energy can be produced by installing hydraulic turbines that are driven by the pumped seawater. In addition, the AWACE unit could produce electric energy by installing a windmill on the platform.

Depending on the size of the facilities, sea states of the geographic area and efficiency of the system, the concept could potentially function as both a fresh water supplier and supplier of electric energy for nearby municipalities and other communities all over the world. In addition, the concept could alone potentially be able to turn desolate areas arable, thus reducing the need for deforestation to make way for farmland.

3.3 THE PUMPING MECHANISM

The pumping mechanism as a concept consists of two versions. The first version regards production of both fresh water and electric energy. The second version excludes the desalination

plant and water production all together and focuses solely on production of electric energy. This section examines further the pumping mechanism of both versions for the AWACE unit described in the previous section.

3.3.1 Version 1. Dual purpose

The first version is an open system as illustrated in Figure 19. The balloon system is installed at a given height above the sea surface, hanging from a vessel or platform deck.

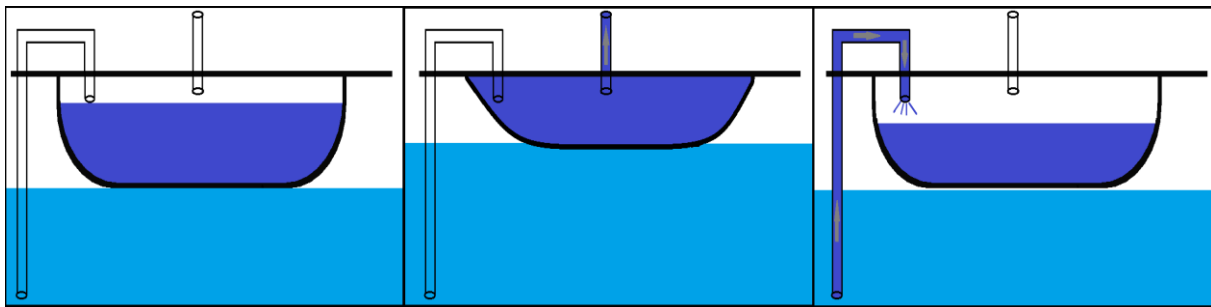

Figure 19. Pump mechanism for open system concept

- Initially, the balloon is in a state where the sea does not affect the balloon substantially, and contains a certain volume of seawater.
- Once a wave hits the balloon, the impact force in combination with buoyancy causes the balloon to be compressed. The compressed volume inside the balloon forces some of the seawater contained within the balloon to be pushed out through an outlet. The displaced water can then be transferred to a temporary storage before further transport.
- After the wave impact on the balloon subsides, the weight of the balloon and its remaining content causes the balloon to return to its original state. As the inner volume of the balloon increases, a low-pressure⁴ system occur within the balloon. The low pressure causes more seawater to be pumped into the balloon. A valve, for example a check valve, can manipulate the flow direction in the pipes.
- The process repeats as long as waves of sufficient size acts upon the balloon.

3.3.2 Version 2. Energy production

The second version of the pump concept is a closed system. In this version, the pump is purposely used only for driving hydraulic turbines for production of electric energy. The closed system does not use an inlet connected to the ocean as a reservoir, therefore the circulating fluid can be substituted from corrosive seawater to lubricating oil. Still, the system works in similar manner to that of the open system, see the illustration in Figure 20.

⁴ The pressure system is defined as low relative to the outer pressure system at atmospheric pressure.

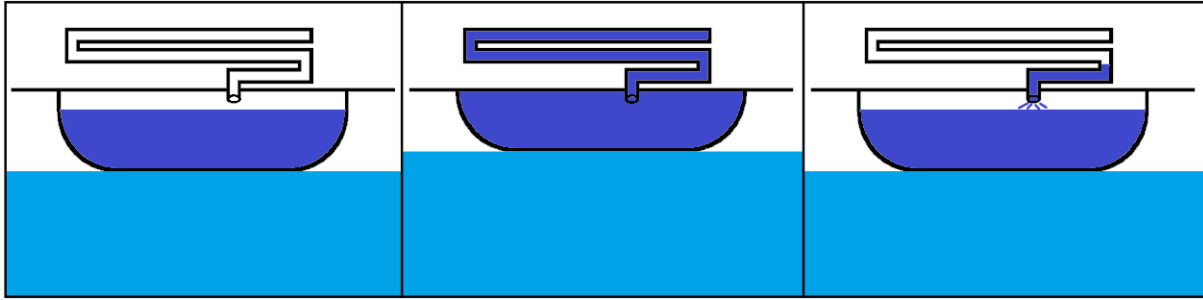

Figure 20. Pump mechanism for closed system concept

- Initially, the balloon is in a state where the sea does not affect the balloon substantially, and contains a certain volume of hydraulic fluid.
- Once a wave hits the balloon, the impact force in combination with buoyancy causes the balloon to be compressed. The compressed volume inside the balloon forces some of the fluid contained within the balloon to be pushed out through a pipe system. The fluid is transported through the pipe with a certain pressure and volume flow rate that drives at least one hydraulic turbine.
- After the wave impact on the balloon subsides, the weight of the balloon and its content causes the balloon to return to its original state. This causes the fluid in the pipe to return into the balloon and the return flow drives the turbine(s) in opposite direction.
- The process repeats as long as waves of sufficient size acts upon the balloon.

3.4 PUMP MECHANISM CONCEPTUAL CHALLENGES

The concept of using the heave motion of ocean waves to displace mass and thereby driving turbines for production of electric energy is not new. However, other similar concepts usually involves displacing air and not liquid. Displacing air or other gasses requires less energy than to displace liquid because the composition is much lighter. Still, the benefit of displacing liquid as opposed to gas is that liquid is practically incompressible, whereas gas is highly compressible.

The volumetric change caused by the wave motion is not fully exploited when the fluid is compressed, rather than displaced. One way of compensating for this problem is by building the production unit in large scale, as with the OWC discussed in the previous chapter, to ensure that the method is economically viable. However, this again causes another problem, sound. A small-scale liquid displacing system would not cause much sound, due to its size, but can still be beneficial since the displaced liquid utilizes more of the energy to drive the turbines. Still, there are numerous challenges with the AWACE Production pump mechanism that needs to be resolved in order to ensure that the pump works effectively and in a reliable manner.

It is vital for the overall efficiency of the pumping mechanism that the contained fluid is forced out of the balloon, rather than being displaced internally within the balloon, as shown in Figure 21. The balloon must be large enough to make the system able to pump and drive turbines, but not so large that the waves merely “massage” the balloon, as shown in the below illustration

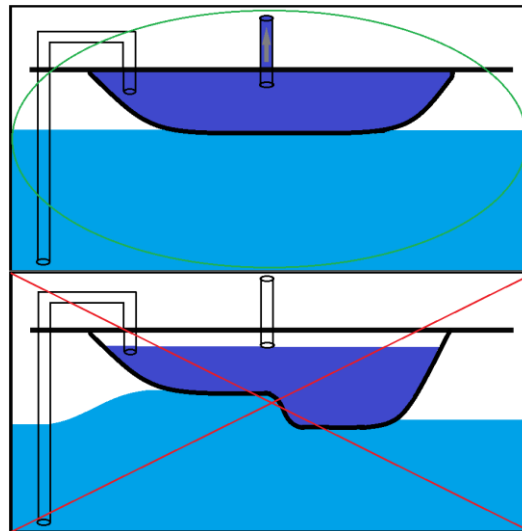

Figure 21. Desired vs. undesired balloon-wave interaction

The desired effect can be achieved, more or less, only when the waves affect the entire cross section of the balloon at once. One way to ensure the waves affect the entire cross section while still having a relatively large balloon is by designing the balloon tall, rather than broad, see Figure 22. This design enables use of several balloons for a given platform deck area. This design is also more feasible from a production and installation point of view. In addition, should the balloon be punctured or otherwise damaged from floating objects then the replacement cost would be less severe per balloon. The other balloons would also be able to function during the replacement process.

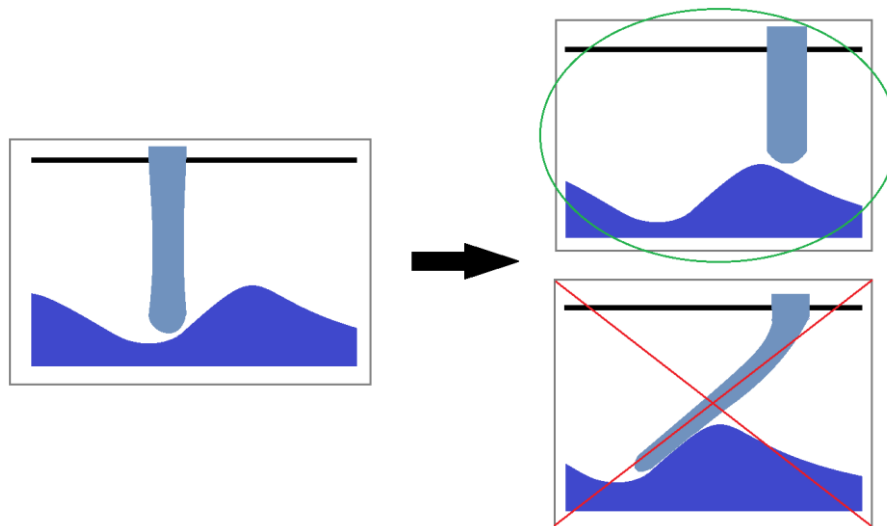

Figure 22. Balloon elongation and return

The tall-balloon design comes, however, with another issue to be resolved. As illustrated in Figure 22, the balloon must go from an elongated state to a retracted state during a wave-interaction cycle. If the balloon is merely pushed aside, then the displacement effect would not be achieved. The student's proposal to overcome this problem is by making the balloon very elastic. This would turn the balloon from a *force-absorption system* to a *spring system*.

Development of a Wave-Driven Pump for Energy Production

The spring system is thought to work as the balloon is initially elongated by weight forces. After which, the buoyancy from wave interaction in combination with the spring force would return the balloon to its original state, thereby pushing the contained fluid out of the balloon. The balloon can be made elastic through design, by using an elastic material or by a combination of both.

The groundwork for both a Norwegian and English patent application has been developed for this pumping method. The potential Norwegian patent document was written in case of applying for a national patent. The document was stamped at the Stavanger courthouse as proof of intellectual property, see Appendix C. However, a product based on this invention would benefit incomparably more from an international patent. For this reason is also the groundwork for an international patent document been developed, see Appendix D.

In closing, so far the reader has been presented with insight in the process of how an issue turned into an idea, and how the idea turned into a concept. Based on the concept described in this chapter, the next chapter presents potentially marketable product-ideas that may be sold as ideas or used as prototypes for building a new company.

CHAPTER 4 – PRODUCT CONCEPT GENERATION

This chapter initializes the development of the production unit based on the student-developed concept covered in the previous chapter. The chapter covers the description and evaluation of three developed housing concepts.

4.1 CONCEPT GENERATION

Concept generation is an early phase of the design process. It is an idea-generating phase and regards developing “the-big-picture” designs. Without going into much detail, engineers come up with a design based on the customer’s needs, while at the same time including a method to avoid the issues of similar current products. In other words, concept generation is the phase where market research and benchmarking comes together and is put to use. A typical method of initializing the concept generation phase is by brainstorming. The brainstorming session should include both experienced and inexperienced members, but can also include outside help, like kitchen staff, family members, etc. because:

The way to get good ideas is to get lots of ideas, and throw the bad ones away. (Pauling)

Whenever engineers or designers are creating something new, it is common practise to develop multiple conceptual versions or multiple versions of design. The versions are compared and graded, until a single version has been chosen for further development. Each version can be made by different teams or by the same team, but in this case, all by the same person. The reason for this multi-concept approach is due to the fact that most of the time; one concept is unable to meet all the desired specifications. Each developed concept has a unique combination of features that comprise both advantages and disadvantages. This method of developing multiple concepts has proven an efficient way to develop a concept that best meet the product requirements. Maybe, it is because the method requires the developers to approach a solution from different angles and thereby giving them a unique vantage point to see both the pros and cons of each concept by comparing and inspiring one another.

The concept explained in Chapter 3 described a jacket platform housing for the pumping mechanism. This not necessarily the ideal housing concept, but was only used to aid in the understanding of the concept at whole. The jacket platform concept was chosen due to its simplicity and also due to its familiarity to the target reader. However, should the pumping mechanism be used to develop a brand new product, then the housing concept must be developed with ingenuity and grace. Especially since the housing concept is a main contributor to the economic viability and also have environmental implications.

For this thesis, three housing concepts have been developed and are illustrated in Figure 23. The figure shows three concepts using the pumping mechanism examined in chapter three. The first concept is the jacket platform, already briefly introduced. The second concept, located upper right, is a jack-up platform, similar to the jack-up platforms used in the oil and gas (O&G) industry. The third concept, shown bottom left, is a floating buoy concept and may share most resemblance with the Pelamis sea snake, described in section 2.6.

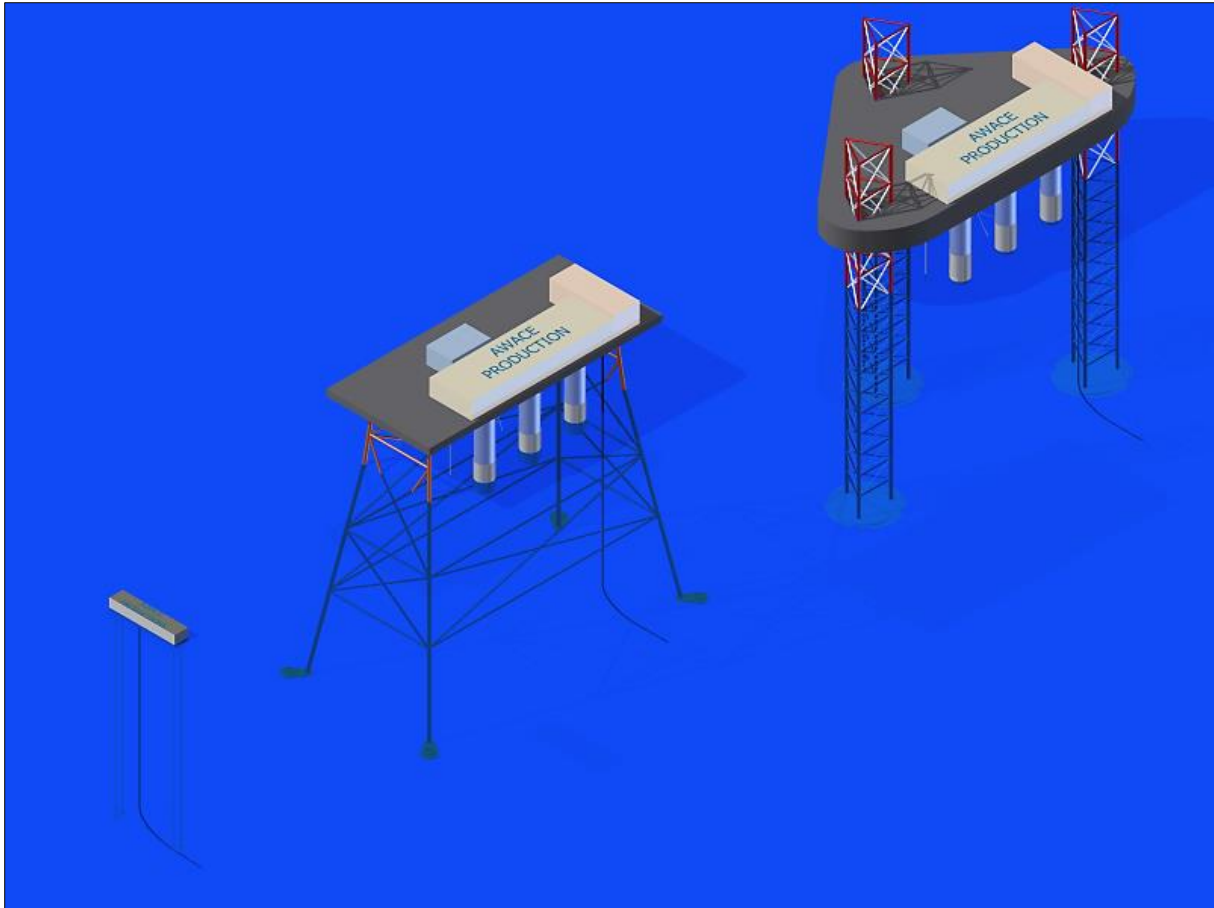

Figure 23. AWACE Production housing concepts

Each of the concepts are examined in closer detail in the following. However, no load calculations, productivity- or cost estimates support these illustrations. These illustrations, made in Autodesk Inventor 2015, serve only the purpose of explaining the individual concept.

4.2 THE JACKET PLATFORM CONCEPT

This platform concept, shown in Figure 24, is based on the conventional jacket structure commonly found in the oil and gas industry. The main difference separating this jacket structure from those of the O&G industry is that the support beams between the main column legs are excluded for a certain sectional length on the “backside” of the platform. This is to prevent the balloons from colliding into the support beams.

The jacket platform is a fixed structure, connected to the sea floor usually by piling or suction anchors. The platform hull is located above the MSL at a safe distance to prevent wave impact. This type of structure has become a standard concept with widespread utilization and varying detailed designs within the O&G industry. However, it requires comprehensive installation procedures and constructional costs that significantly increases with water depth.

The jacket structure is a robust structure granting the opportunity of implementing both windmills and ocean current-driven turbines, but elevation and air-gap requirements may constrain the design possibilities of the balloons. The jacket platform concept maintain most of the equipment above the sea, and mainly above deck, which is a far less corrosive environment

than the sea. This also allow for easy access during inspection and maintenance. A helicopter deck installed on the topside can grant quick and safe access to the platform.

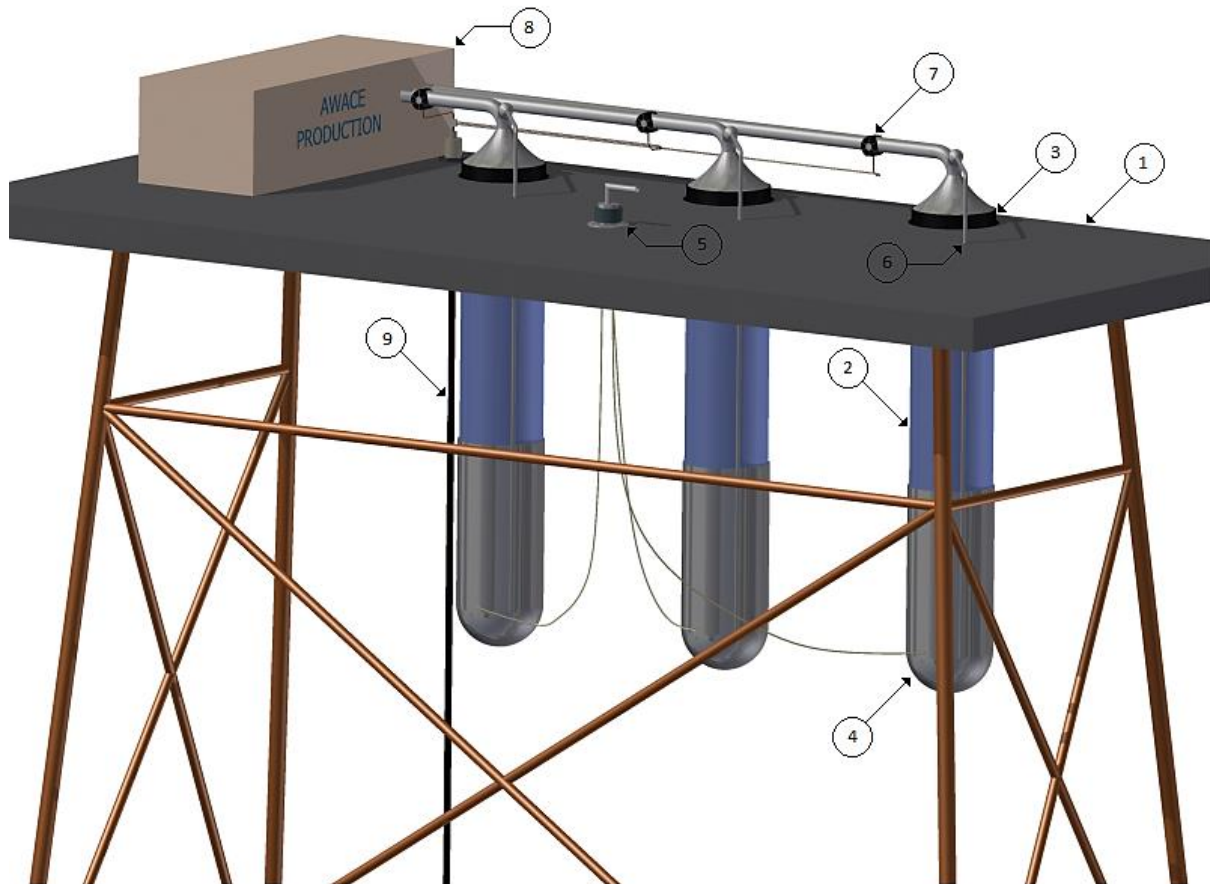

Figure 24. Jacket platform concept

Components

1. Jacket platform	2. Balloon	3. Clamp
4. Buoyancy module	5. Pump	6. Intake
7. Outlet + turbine	8. Storage	9. Umbilical

Jacket platform

A benefit from using a jacket platform concept is the ability to repurpose current jacket platforms used in the O&G industry today. Modularly installed, the standard topside of a jacket platform can also be lifted off, to be replaced by an AWACE Production topside. However, the jacket platform is normally designed in accordance with the expected lifetime of the oilfield. Meaning that the platform may no longer be safe to use once the wells are dry and the platform is ready for repurposing.

Since the production process of the AWACE Production unit is autonomous, no personnel are required to remain on-site during bad weather. Therefore, the risk picture for human injury and loss of lives is significantly reduced from the original jacket platform. In addition, the risk picture for the AWACE Production platform is significantly lower than that of a hydrocarbon-producing platform regarding environmental consequences. The AWACE Production topside

Development of a Wave-Driven Pump for Energy Production

equipment is also expected to weigh less than the original topside. Therefore, with the reduced load and reduced risk picture, the jacket structure may be allowed for further use.

Balloon

The balloons in this concept are designed as large cylinders. They are designed to be elastic by making them from a highly elastic material, like latex. Rubber materials come in a variety of compositions with both good yield strength and a sufficient ability to elongate. The elongation limit for the various rubber composites has a wide range, typically within 50 per cent to 1000 per cent, and this ability is kept intact in temperatures as cold as 50 degrees Celsius below zero (Rubber Style, 2016).

Clamp

The balloons are fixed to the platform hull with a clamp mechanism. The clamp mechanism, in contrast to other constraining methods like bolt mechanisms, does not require the balloon to be machined. Machining the balloon would be quite difficult or expensive to carry out accurately, but would also reduce the cross sectional strength of the balloon by stress concentration. The clamp mechanism may also prove ideal for an emergency release system, similar to the release method of turrets used on ship-shaped floating production, storage and offloading (FPSO) units.

Buoyancy module

Connected to the bottom of the balloon is a buoyancy module (BM). In this concept, the buoyancy module is the component that resides in the wave zone, thereby significantly reducing the risk of balloon puncture from floating objects. However, the main purpose of the BM is to act as a separate compartment of the balloon.

The BM can have fluids pumped in and out of the compartment to regulate the mass of the spring-system, thereby adjusting the Eigen-frequency of the system to match the natural frequency of the ocean heave motion to obtain optimal heave motion or even resonance. In contrast, this method is also used on semi-submersible platforms where fluids are pumped into the columns to add mass, or pumped out to raise the platform to float on its pontoons. Either way, the Eigen-frequency in heave is altered to refrain from resonance.

The BM should consist of not one large compartment, but of several smaller compartments. Thereby reducing or even eliminating sloshing effects within the module.

Another benefit by changing the mass of the buoyancy module is to regulate the initial elongation of the balloon to compensate for MSL changes caused by tidal effects. As a final note, the BM is designed with a circular cross section to limit the torsional and translational motions caused by wave impact on the module.

Conduits

In the case of utilizing the pump mechanism version 1, from section 3.3, the balloon connects to the sea via a seawater intake. An outlet with an integrated hydraulic turbine further connects the balloon to a water storage tank. The electric energy produced from the hydraulic turbines and the stored water is by a common umbilical transferred to land.

4.3 THE JACK-UP PLATFORM CONCEPT

The jack-up concept, shown in Figure 25, is based on the conventional jack-ups commonly found on the Norwegian continental shelf in the O&G industry. The jack-up is considered a fixed platform, but also include mobility. While set on location, the jack-up legs are fixed to the seabed, but these legs can be disconnected from the ocean floor and “jacked-up” by cogwheels and planetary gears hereby allowing the jack-up to float on its topside.

The jack-up platform is a self-installing structure, connected to the ocean floor during production. The jack-up’s ability to elevate its topside gives this structure, compared to other fixed offshore structures, a unique capability to adapt the air gap according to the current sea state. This type of structure is based on well-proven technology and is supported by many years of constructional experience in the oil and gas industry.

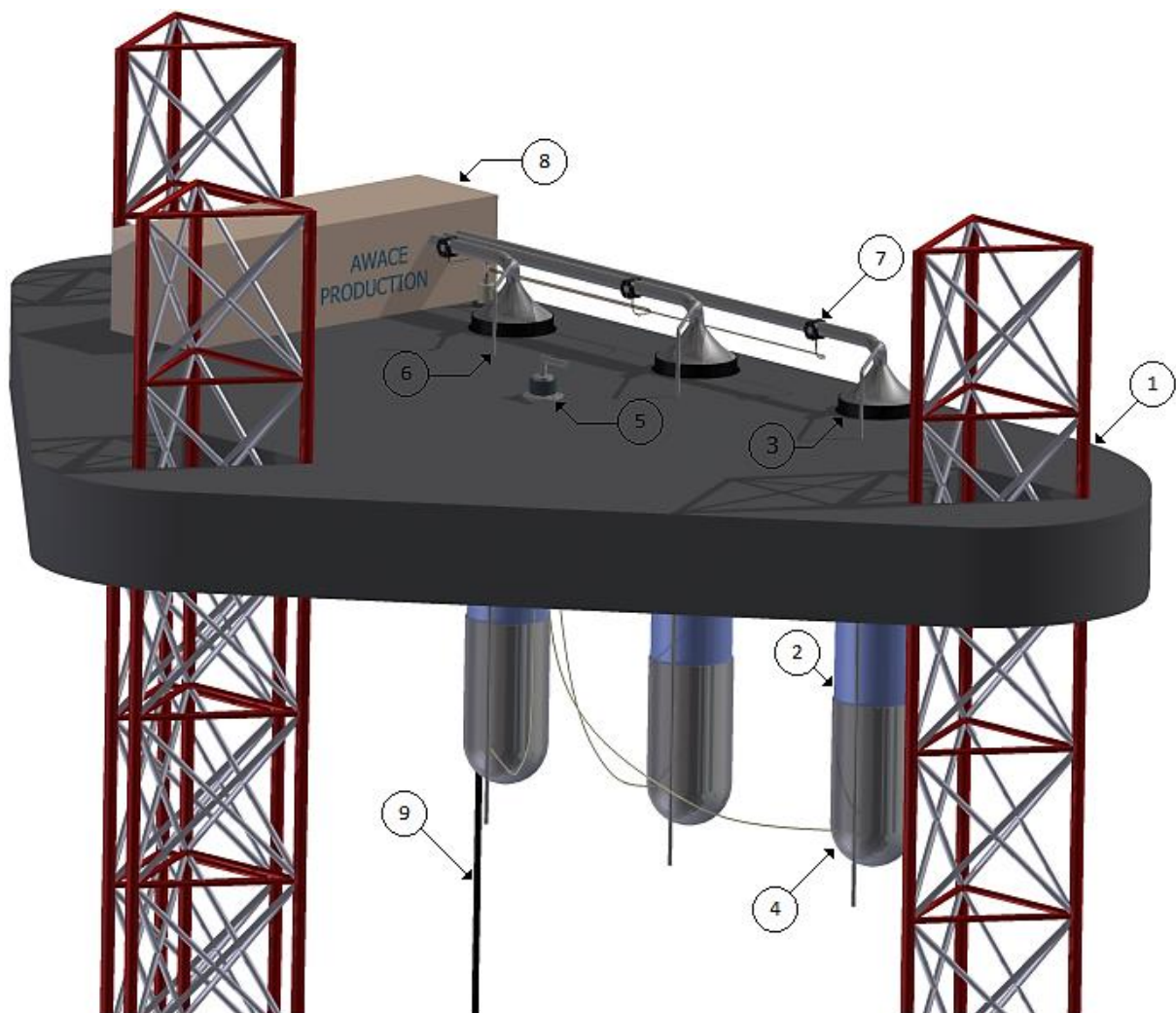

Figure 25. Jack-up platform concept

Components

1. Jack-up platform	2. Balloon	3. Clamp
4. Buoyancy module	5. Pump	6. Intake
7. Outlet + turbine	8. Storage	9. Umbilical

Development of a Wave-Driven Pump for Energy Production

Jack-up platform

An advantage of using the jack-up concept over the jacket concept is that its legs are easier to construct than the jacket structure. In addition, the topside can be installed at shore and in fjords with simple marine operations. However, this structure is more limited by water depth than the jacket platform. In the oil and gas industry, these are normally constrained to a depth between 120-170 metres, compared to the jackets of the O&G industry which are normally limited to a depth of 300 metres.

The jack-up's topside allow for installing windmills to increase electric energy production. Ocean current turbines may also be installed between the jack-up legs, though at this point not considered an option. The jack-up concept maintains most of the equipment above the sea, and mainly above deck, which is a much less corrosive environment. This also allows easy access during inspection and maintenance. A helicopter deck installed on the topside can grant quick and safe access to the platform. The topside's elevating ability allows the balloons to be designed for optimal productivity. By adjusting the topside according to the sea state instead of the balloon's initial elongated length, as with the jacket platform, can the natural heave frequency of the pump remain unchanged.

Another benefit from using the jack-up platform concept is the possibility to repurpose current jack-ups used in the O&G industry today. Modularly installed, the standard topside of a jack-up platform can also be replaced by an AWACE Production topside. Again, for this concept, the expected topside equipment weight is less than its predecessor, and have less human- and environmental risk. This may allow repurposing for further use of obsolete O&G jack-ups.

Balloon

The balloons of this concept are designed as large cylinders. They are designed to be elastic by making them from a highly elastic material, like latex. Rubber materials comes in a variety of compositions with both good yield strength and a sufficient ability to elongate. The elongation limit for the various rubber composites has a wide range, typically within 50 per cent to 1000 per cent, and this ability is kept intact in temperatures as cold as 50 degrees Celsius below zero.

Clamp

The balloons are fixed to the platform hull with a clamp mechanism. The clamp mechanism, in contrast to other constraining methods like bolt mechanisms, does not require the balloon to be machined. Machining the balloon would be quite difficult or expensive to carry out accurately and would also reduce the cross sectional strength of the balloon by stress concentration. The clamp mechanism may also prove ideal for an emergency release system, similar to the release method of turrets used on ship-shaped FPSO units.

Buoyancy module

Connected to the bottom of the balloon is a buoyancy module. In this concept, the buoyancy module is the component that resides in the wave zone, thereby significantly reducing the risk of balloon puncture from floating objects. However, the main purpose of the buoyancy module is to act as a separate compartment of the balloon. The buoyancy module can have fluids

pumped in and out of the compartment to regulate the mass of the spring-system, thereby adjusting the Eigen-frequency of the system to match the natural frequency of the ocean heave motion to obtain optimal heave motion or even resonance. The buoyancy module should consist of not one large compartment, but of several smaller compartments. Thereby reducing or even eliminating sloshing effects.

Conduits

In case of utilizing the pump mechanism version 1, from section 3.3, the balloon connects to the sea via a seawater intake. An outlet with an integrated hydraulic turbine further connects the balloon to a water storage tank. The electric energy produced from the hydraulic turbines and the stored water is by a common umbilical transferred to land.

4.4 THE BUOY CONCEPT

The third and final of the concepts introduced in this document is the buoy concept. This concept, based on the floating buoy principle, differs considerably from the foregoing concepts. Here, a container-like structure houses the pumping mechanism. The container is tethered to the sea floor, making it more suitable in deeper waters compared to the foregoing concepts. The buoy concept comprises pumping compartments, hereby referred to as *lungs*. As shown in Figure 26, the buoy comprises two lungs, but is in no way limited to this amount.

Inspired by the moon pool technology utilized on floating drilling units in the oil and gas industry, each lung has an open section that allow waves to enter. This design reduces transverse wave impact forces on the balloon, while maintaining the vertical impact- and buoyancy force.

The buoy does not include a method of transporting seawater, but is limited to the production of electric energy. The buoy is relatively small compared to the two other concepts. The small size makes the concept harder to spot from the coastline and thus more likely to be accepted by possible nearby communities.

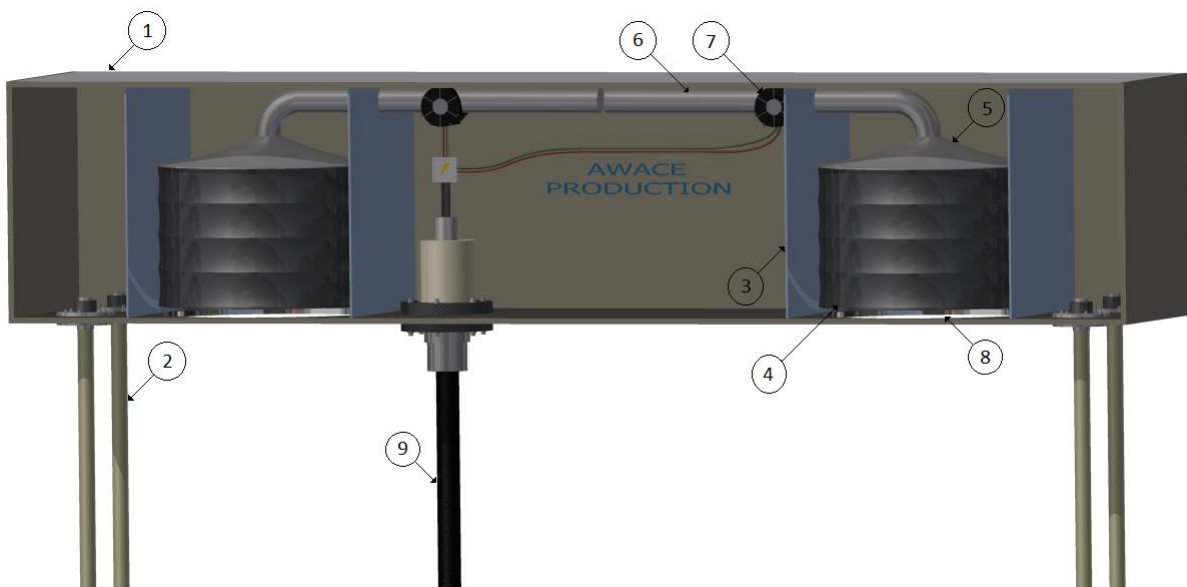

Figure 26. Floating buoy concept

Development of a Wave-Driven Pump for Energy Production

Components		
1. Container	2. Mooring line	3. Lung wall
4. Balloon	5. Funnel	6. Tube
7. Turbine	8. Moon pool	9. Umbilical

Container

The container housing shown in the above figure has a simple design. In case of further work, detailed engineering would consider a design more adapted to its environment, including a shape reducing hydrodynamic resistance from waves. The buoy resides on the ocean surface, making it far more susceptible to corrosion compared to the foregoing concepts. The container is the primary barrier for the rotating components and other equipment from the corrosive seawater. The container also protects the balloon's rubber material from sunlight corrosion, a feature unique to this concept.

Mooring line

Mooring lines connected to the ocean floor restrain the container. Depending on buoy size and the water depth of location, the mooring line type may vary. In the above figure, tether lines moor the container. Tether lines limit the container's heave motion and thus increases the pushing effect waves have on the balloon. However, with the tether line configuration the buoy is prone to the *set-down effect*. Detailed engineering would have to overcome the reduced pumping efficiency caused by this effect.

Balloon

In this concept, the balloons are designed as springs enveloped in an elastic material. The proposed elastic material is natural rubber. This is a material with good yield strength and sufficient elongating ability. Natural rubber is also corrosion resistant to seawater as well as to oils. The spring acts like a skeleton to maintain the balloons diameter during the various stages of elongation and limits the effect of hydrostatic pressure. The spring has more machinability than a single-component rubber balloon. The spring makes it thus possible to use bolted connections. The balloon in this concept has a solid flat bottom for optimal pushing-effect from the waves.

Funnel

The balloons hang from a funnel, fixed with a bolted connection to the spring. The funnel shape allows for better flow out the balloon and into the tube.

Tube

The tube conveys the hydraulic fluid back and forth through a turbine that produces electric energy regardless of flow direction. Retraction of the balloon forces fluid out through the funnel and into the tube. At which point the innermost part of the tube will then hold a section of compressed air. This air will act like a spring with potential energy that helps push the fluid back into the balloon when the balloon extends, improving flow rate and pressure through the turbine.

4.5 CONCEPT SELECTION

An easy misconception about concept selection is considering it as a way of selecting the best concept. However, concept selection is not a competition where a winner is chosen, but rather a process to develop the best concept (MIT, 2014). The combination of concept generation and concept selection can be a multi-step process. The process starts with a number of concepts screened to filter out the best concepts. These concepts are then further developed, which include combining the best features of the various concepts and removing the bad features. After development, the improved concepts are again screened to filter to out the best of the best. This process may be repeated until a single concept has been defined as the best-fit concept.

As for this thesis, the concepts that were generated did not include multiple screenings, but were developed in parallel with each other. The disadvantage of one concept became the inspiration for another concept, and at the same time, the advantage of one concept became the goal of the other concepts. Still, prior to further development, a single concept had to be filtered out.

The standard method of filtering out a final concept is by evaluating them in terms of scores. Usually by the [+ , 0 , -] principle where 0 is the point of reference or by numerical values, typically 1-5. The evaluation is either *qualitative* or *quantitative*. The latter refers to an evaluation where the concepts are graded by measureable values, such as energy output [MW], sales price [NOK], expected lifetime [Years] and so on. The qualitative evaluation regards specifications such as including features and abilities, handheld feeling, aesthetics, etc.

The selection criteria from which the concept evaluations are based upon generally reside within one of the following three aspects; see reference (MIT, 2014).

- Customer and other stakeholder needs
 - Based on market research and other stakeholders' input
 - Based on competitive or otherwise related products
 - Often qualitative – Example: Product looks good
- Technical demands or performance requirements
 - Often quantitative – Example: Product supplies energy equivalent to 200 average households
 - Early design evaluations of more complex products may be qualitatively based by addressing features and abilities
- Process or enterprise related issues
 - Manufacturing and development costs
 - Development time and time to market

A single person or team of concept developers can quickly develop sentimental feelings for a concept after working on it a certain amount of time. Particularly with a single person if it was his/her idea and pride may become a distractive element. When that happens, a concept-scoring matrix, like the one of Table 2, can easily be shaped to benefit the favoured concept by playing down disadvantageous criteria or promoting beneficial criteria. This can happen both intentionally or unintentionally, but regardless of intent perpetuates the development of perhaps not the best concept. One way to prevent this from happening is by including independent

individuals to take part in the selection process. This can be engineers working on different projects, hired expertise, etc.

Another preventive step is clearly defining the selection criteria prior to concept generation. However, concepts can gain unforeseen specifications during the development process that are important to consider. Meanwhile, the score evaluation performed in this section does not consider the actual pumping mechanism from Chapter 3, but rather the housing concepts for the pumping mechanism. This enables the screening to be conducted as a comparison of the concepts based on each other’s specifications, instead of comparing the concepts to predefined target specifications.

The screening of the three housing concepts described in this chapter is based on a qualitative evaluation using the [+ , 0 , -] ranking system, see Table 2. The individual scores are based on the concept descriptions and perceptive judgement related to future project aspects.

Table 2. Concept housing scoring matrix

Selection Criteria	Concept			Reference Value
	Jacket	Jack-up	Buoy	
Robust housing method	+	0	-	0
Expected project risk for single 1:1 prototype	-	0	+	0
Based on conventional technology	0	0	-	0
Simplicity of at-site maintenance and inspection	0	0	-	0
Storm survivability	0	0	-	0
Dual-purpose pumping potential	0	0	-	0
Adaptability to tide	0	+	+	0
Ability to regulate system’s natural frequency	0	+	-	0
Ability to include windmills	0	0	-	0
Ability to include ocean-current turbines	0	-	-	0
Constructional complexity	-	0	+	0
Topside installation complexity	-	0	+	0
At-site installation complexity	-	+	0	0
Disturbance to local communities or wildlife	0	0	+	0
Equipment corrosion exposure	+	0	-	0
Water depth dependent	0	-	+	0
Minuses	4	2	9	
Zeros	10	11	1	
Plusses	2	3	6	
Result	-2	1	-3	
Rank	2	1	3	
Continue?	No	Yes	No	

The table shows that the number one ranked concept stands above the concept ranked number two by three points. The conclusion to this evaluation process is therefore that concept number two, the jack-up concept, is the concept best suited for further development. Still, this does not necessarily have to be the case. The evaluation does not take into account the importance of each selection criteria, but assumes all as equally important.

A more detailed grading method may prove a different concept as best suited. The results of this evaluation, however, are deemed valid. The continuation of the development process in the next chapter comprises therefore the pumping mechanism, described in the previous chapter, housed with the jack-up platform concept.

CHAPTER 5 – PLATFORM ELEVATION

This chapter initializes the more detailed design of the pump mechanism. Based on the conclusion of the previous chapter, this chapter covers the elevation and air gap design for the jack-up platform.

5.1 ELEVATION AND AIR GAP OVERVIEW

The pumping mechanism, and more specifically, the balloon requires a preliminary design before establishing the energy production potential of the concept. The initial step of developing the design of the balloon is determining its most important dependencies. With platform housing, the balloon height depends strongly on the topside elevation requirement. Meanwhile, the initial idea is that the production unit will not be in operation during a storm. However, designing the balloon as hanging from the topside while in the elevated position corresponding to the storm requirement may prove a good reference point during detailed engineering. There are also other benefits to doing so as part of this thesis:

- The elevated height and air gap requirement for the platform during storm should be established nonetheless.
- *Det Norske Veritas* (DNV) has a straightforward method for determining the required elevation and air-gap of fixed, floating and self-elevating offshore units during storm.

The distance between the hull structure and the maximum surface elevation (SE) is the definition of air gap. The crest elevation defined as shown in Figure 27 below.

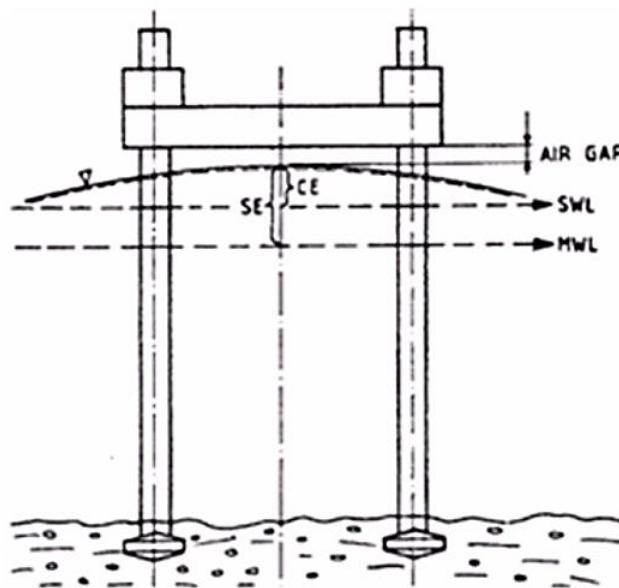

Figure 27. Illustration of crest elevation and air gap (DNV, 2011)

The sea elevation is the combination of wave crest at mean water level (MWL) plus highest astronomical tide and storm surge. The air gap requirement should be no less than ten per cent of the crest elevation, but need not exceed 1.2 metres.

5.2 CALCULATING ELEVATION

This section covers the calculation of the required topside elevation based on DNV's recommended practise and the parameters of the selected area for operation.

5.2.1 Location of operation

In case the invention would be a marketable product then the development process of the wave energy converter would eventually require a full-scale prototype. During the master's program, the inventor has developed numerous connections in Stavanger, including professors at the University of Stavanger and a consultancy firm. Stavanger would therefore be a good base from which to continue the development process. Since it is advantageous to locate the full-scale prototype close to base, the location of the unit is decided to be south-southwest of Stavanger, see encircled area of Figure 28.

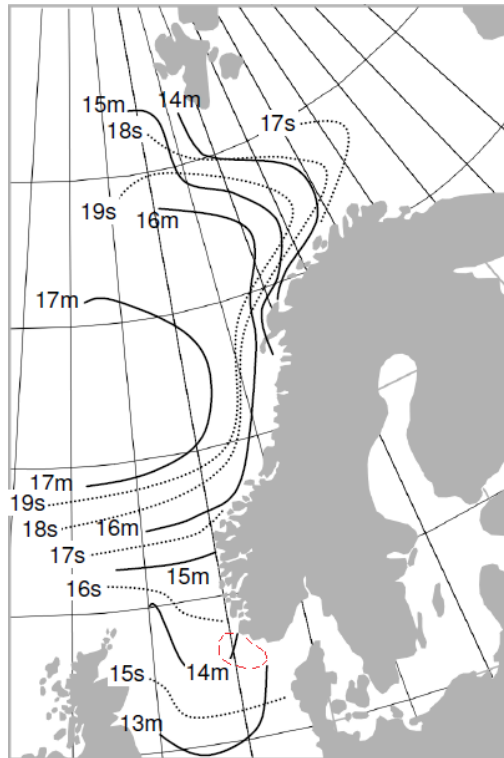

Figure 28. Proposed location of operation (NORSOK, 2007)

This area is part of the southern North Sea and is a relatively shallow area. The water depth generally does not exceed a depth of 50 metres, which is suitable for the jack-up structure (Institute of marine research, 2014). As part of further calculations, Eq. (5.1) expresses the assumed mean water depth at the location.

$$d = 50[m] \quad (5.1)$$

The height of storm surge for this area is based on the 200-year storm surge height measured at the coast of Stavanger, see Eq. (5.2) (Norwegian Environment Directorate, 2016).

$$h_{ss} = 1.2[m] \quad (5.2)$$

The highest astronomical tide for the area, expressed in Eq. (5.3), is based on the HAT-value for Stavanger according to measurements given in Appendix B.

$$h_{HAT} = 1.11[m] \quad (5.3)$$

With storm surge and tide determined, the last remaining parameter in estimating the required elevation and air gap is the wave crest. Figure 28 shows that the chosen area has, for a three-hour sea state in a 100-year storm, a significant wave height between 13 and 14 metres. As part of the calculations, the assumed wave height expressed in Eq. (5.4) is the average of these two values.

$$H_s = 13.5[m] \quad (5.4)$$

The figure also shows that the peak period of the waves for the chosen area ranges between 15 and 16 seconds. Expressed in Eq. (5.5), the average value is again assumed as part of the calculations.

$$T_p = 15.5[s] \quad (5.5)$$

Assuming an intermediate water depth for the sea with the above given parameters. The wavelength is determined by Eq. (5.6) (see Appendix A).

$$L = \frac{g}{2\pi} \cdot T^2 \tanh(kd) \quad (5.6)$$

With the wave number, k , determined by $k = \frac{2\pi}{L}$, iteration results in the wavelength given in Eq. (5.7).

$$L = 295[m] \quad (5.7)$$

The intermediate water depth assumption is true if the water depth over wavelength relation ranges between 0.05 and 0.5.

$$\frac{1}{20} < \left(\frac{d}{L} = 0.169 \right) < \frac{1}{2} \quad (5.8)$$

The relation in Eq. (5.8) lies between the criteria boundaries and therefore proves intermediate water depth. Lastly, Eq. (5.9) checks if the sea state is applicable for linear wave theory by comparing the relation of significant wave height over wavelength with the requirement.

$$\left(\frac{H_s}{L} = 0.0457 \right) < \frac{1}{7} \quad (5.9)$$

The wave height/wavelength relation is less than 0.142 and thus linear wave theory is applicable for calculation of the wave crest.

5.2.2 Calculating wave crest and elevation requirement

The wave crest calculations in this section are based on the parameters given in the foregoing section. The calculation method is standard practise given by DNV (source: (DNV, 2010a)).

If the criteria of Eq. (5.10) is met then the JONSWAP spectrum, shown in Figure 29, is applicable representation of wave spectrum for the given sea state.

$$3.6 < \frac{T_p}{\sqrt{H_s}} < 5 \quad (5.10)$$

Inserting the values results in the relation $T_p / \sqrt{H_s} = 4.22$. The spectrum is an appropriate model since this value lies within the criteria boundaries.

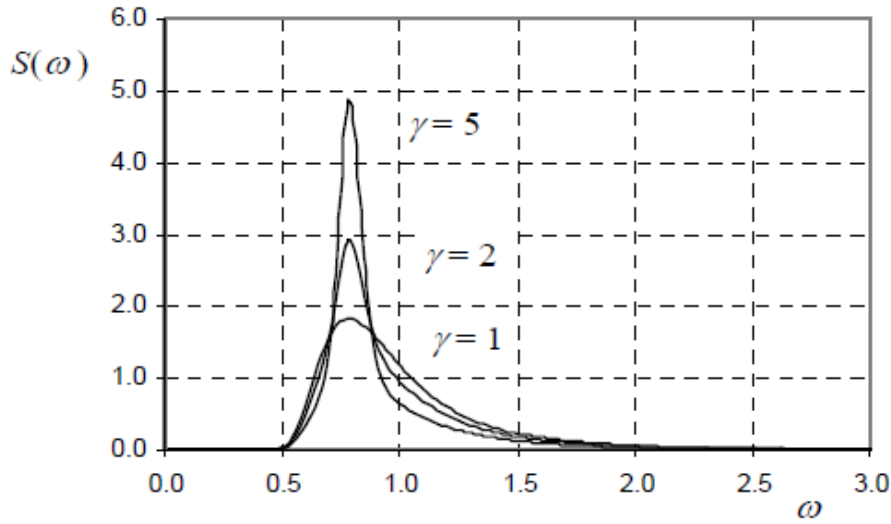

Figure 29. JONSWAP wave energy spectrum with shape parameters $\gamma=1$, $\gamma=2$ and $\gamma=5$

The JONSWAP shape parameter for this sea state is given by Eq. (5.11).

$$\gamma = \exp\left(5.75 - 1.15 \cdot \frac{T_p}{\sqrt{H_s}}\right) \quad (5.11)$$

$$\gamma = 2.45 \quad (5.12)$$

The parameter given in Eq. (5.12) lies between 1.0 and 7.0. The shape parameter is therefore appropriate to use in Eq. (5.13) to determine the relation between the zero-upcrossing wave period, T_z , and the peak period.

$$\frac{T_z}{T_p} = 0.667 + 0.0504\gamma - 0.00623\gamma^2 + 0.000334\gamma^3 \quad (5.13)$$

Rearranging and calculating results in Eq. (5.14) to express T_z from T_p .

$$T_z = 0.758 \cdot T_p \quad (5.14)$$

In the same manner, the mean wave period, T_l , is calculated in Eq. (5.15).

$$\frac{T_l}{T_p} = 0.730 + 0.0494\gamma - 0.00656\gamma^2 + 0.000361\gamma^3 \quad (5.15)$$

Again rearranging and calculating results in Eq. (5.16) as an expression for T_l .

$$T_1 = 0.817 \cdot T_p \quad (5.16)$$

Forristall, F_c , and second order theory, see Eq. (5.17), can sufficiently model the wave crest of the nonlinear behaviour of the ocean surface.

$$F_C(h_{wc}) = 1 - \exp\left(-\left(\frac{h_{wc}}{\alpha_c H_s}\right)^{\beta_c}\right) \quad (5.17)$$

Here, the Weibull parameters α_c og β_c are given as a function of the wave steepness, S_1 , and the Ursell number, U_{rs} . The steepness is given in Eq. (5.18).

$$S_1 = \frac{2\pi H_s}{g T_1^2} \quad (5.18)$$

$$S_1 = 0.0539 \quad (5.19)$$

The Ursell number is given by Eq. (5.20).

$$U_{rs} = \frac{H_s}{k_1^2 \cdot d^3} \quad (5.20)$$

Here, k_1 is the intermediate water wavenumber and given by Eq. (5.21).

$$\tanh(k_1 \cdot d) k_1 = \frac{4\pi^2}{g T_1^2} \quad (5.21)$$

$$k_1 = 0.0283 [m^{-1}] \quad (5.22)$$

Calculation of Eq. (5.20) by inserting the values of Eq. (5.1), (5.4) and (5.22) results in the Ursell number of Eq. (5.23).

$$U_{rs} = 0.135 \quad (5.23)$$

The Weibull parameters for two-dimensional long-crested waves can thus be calculated. The alpha values are given by Eq. (5.24).

$$\alpha_c = 0.3536 + 0.2892 \cdot S_1 + 0.106 \cdot U_{rs} \quad (5.24)$$

$$\alpha_c = 0.383 \quad (5.25)$$

Meanwhile, the beta values are given by Eq. (5.26).

$$\beta_c = 2 - 2.1597 \cdot S_1 + 0.0968 \cdot U_{rs}^2 \quad (5.26)$$

$$\beta_c = 1.885 \quad (5.27)$$

The extreme wave crest above mean water level can be calculated through the *environmental contour method* in Eq. (5.28). The method uses a fractal value between 0.75 and 0.9. Since the platform is designed to be unmanned during storm, the fractal is chosen to the lowest value.

$$F_C(h_{wc})^{N_{3h}} = 0.75 \quad (5.28)$$

Development of a Wave-Driven Pump for Energy Production

Here, N_{3h} is the number of wave crossing during a three-hour storm, as calculated by Eq. (5.29).

$$N_{3h} = \frac{10800[s]}{T_z} \quad (5.29)$$

$$N_{3h} = 919 \quad (5.30)$$

Rearranging Eq. (5.17) gives an expression for the height of maximum wave crest, see Eq. (5.31). The full calculation is given Appendix E.

$$h_{wc} = \alpha_C \cdot H_s \cdot \left(-\ln \left(1 - 0.75^{\frac{1}{N_{3h}}} \right) \right)^{\frac{1}{\beta_C}} \quad (5.31)$$

$$h_{wc} = 15.7[m] \quad (5.32)$$

The calculation process results in a wave crest elevation of 15.7 metres above the mean sea level. A value for the crest-elevated height is in Eq. (5.33) and is the result of adding the height of elevation from storm surge and tide to the wave crest height.

$$h_{ce} = h_{wc} + h_{ss} + h_{HAT} \quad (5.33)$$

$$h_{ce} = 18.0[m] \quad (5.34)$$

The air gap is required to be ten per cent of the crest-elevated height, which is 1.8 metres. However, the requirement does not need to exceed 1.2 metres. Therefore, the air gap expressed in Eq. (5.35) is in this case determined to 1.2 metres.

$$a = 1.2[m] \quad (5.35)$$

Adding the air gap to the crest-elevated height of the waves declares that the jack-up platform during storm must be elevated to a height of 19.2 metres, see Eq. (5.36). This value assumes ideal sea bottom characteristics.

$$h_e = 19.2[m] \quad (5.36)$$

This height functions in this document as the reference height for the preliminary balloon design.

CHAPTER 6 – PUMP DESIGN & THEORETICAL EFFICIENCY

This chapter introduces a suggested design for the pump. A set of criteria and operational boundaries forms the initial design of the pump mechanism. These criteria and boundaries are in this chapter examined, followed by the calculation of the theoretical electric energy production efficiency. An array of simplifying assumptions and set feasible parameters form the concluding theoretical efficiency of the suggested design.

6.1 PUMP DESIGN CRITERIA

From the previous chapter it was decided that the elevated height of the bottom of the platform hull was to be 19.2 metres above the MSL. This height is the reference height for the length of the pump section underneath the platform. In Figure 30, it is assumed that the entire balloon is situated underneath the platform hull. The pump can be viewed as consisting of five sections, illustrated in Figure 30 below. Clamps are in this chapter excluded.

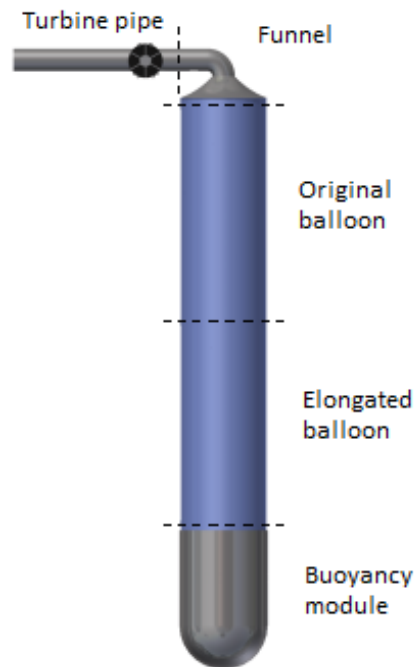

Figure 30. AWACE Production pump's sectional build-up

All five sections comprise a set of design criteria. Listed from top to bottom, these five sections are:

- Turbine pipe
 - Small⁵ diameter increases flow rate and dynamic pressure in the pipe
 - Small diameter increases effect of pipe friction
 - Large diameter reduces required funnel size
- Funnel
 - Larger funnel allows smoother flow out of balloon and into turbine pipe, thus reducing system damping caused by flow resistance

⁵ Small or large turbine pipe diameter is a descriptive term relative to the diameter of the balloon. The turbine pipe will always have a smaller diameter than the balloon.

Development of a Wave-Driven Pump for Energy Production

- Smaller funnel reduces elevation of flow, thus increasing flow pressure in turbine pipe
- Smaller funnel increases volume of flow through turbine
- Original balloon
 - Larger balloon length increases construction costs
 - Smaller balloon length requires more flexible material to obtain required elongated length
 - Smaller diameter reduces construction costs per unit
 - Larger diameter increases displaced fluid and thus efficiency of each wave period
- Elongated balloon
 - Less elongation means less strain on material
 - More elongation increases the ability to utilize higher waves
 - More elongation requires larger balloon or more flexible material
- Buoyancy module
 - Reducing size reduces construction costs
 - Increasing size increases volume for ballast, giving the pump a wider range of possible Eigen-frequencies
 - Increasing size increases available buoyancy to force fluid through the funnel

These criteria must be recognised and implemented in the design in a balanced fashion to obtain the best functioning pumping mechanism. In addition to these design criteria there are also hidden criteria. These are the criteria that have not yet been established. Detailed engineering and testing is likely to reveal more design criteria to be taken into account in future work.

6.2 PUMP DESIGN OPERATIONAL BOUNDARIES

Each AWACE unit requires the pump system to be designed in accordance with its intended operational area. An operational area was proposed in Chapter 5 with the intent to obtain a reference height of a suitable platform elevation. However, in this chapter the operational sea state is not determined from that area. Instead, this chapter assumes a number of feasible swell seas to project a range of possible energy production capabilities.

As part of establishing the operational boundaries, the largest of the swell seas in which the production unit can operate is assumed to consist of ten-metre waves. This wave system further assumes two-dimensional and perfect sinus-curved waves. This implies that every wave is of same height with five-metre trough and five-metre crest from the MSL. Figure 31 illustrates the wave system with its y-axis positive in the downward direction and with origin (zero) in the platform hull bottom. The balloon's maximum elongation during operation is assumed as 100 per cent of original length.

Based on the required platform elevation determined in Chapter 5, the distance from MSL to top of the balloon is 19 metres. The smallest air gap is thus 19 metres subtracted by the height of the wave crest. The smallest air gap equals 14 metres, see Eq. (6.1).

$$a_{\min} = 14[\text{m}] \quad (6.1)$$

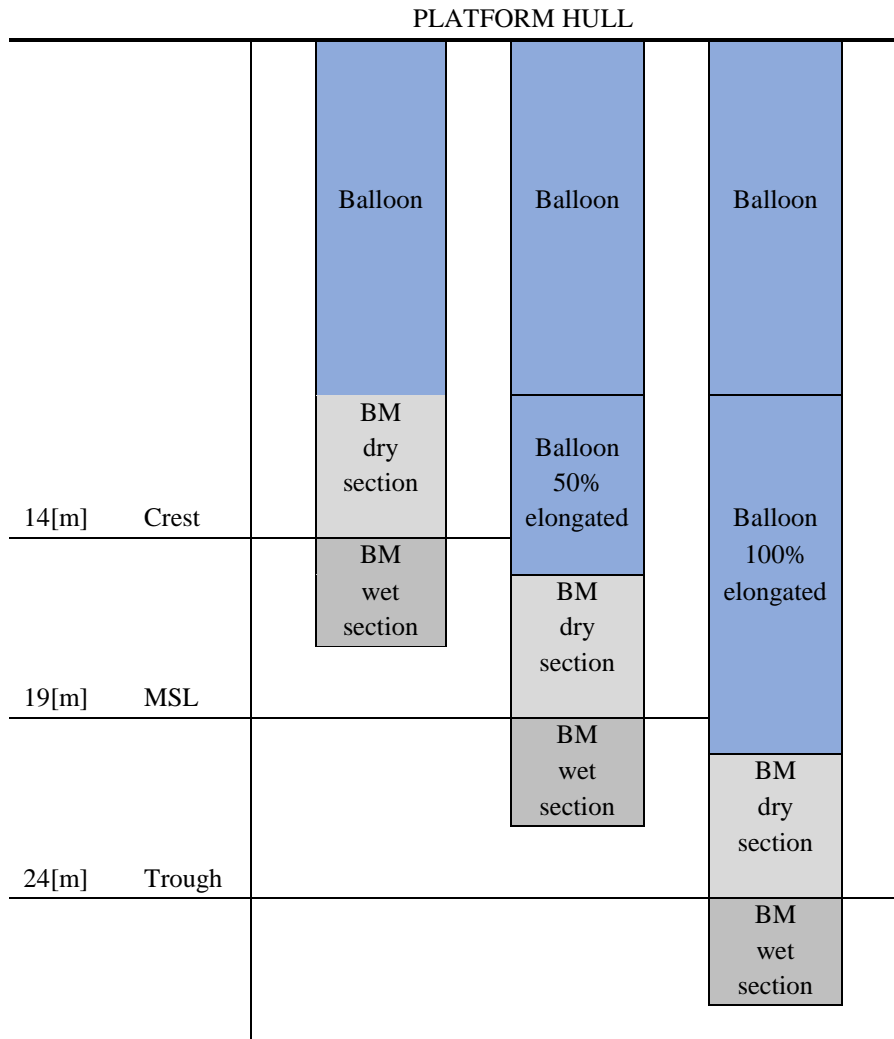

Figure 31. Illustration of pump mechanism operating in waves

The balloon should be designed to never fully retract, so there will always be a certain elongation to prevent buckling behaviour that is expected to occur when fully retracted. The combined length of the balloon and maximum dry section of buoyancy module is therefore designed smaller than the air gap, described by Eq. (6.2).

$$(l_b + l_{bm,dry}) < a_{\min} \quad (6.2)$$

The pump can only achieve its full potential if it utilizes the entire height of the waves. Therefore should the elongation during operation be at least equal to the wave height. In which case the minimum elongation requirement is the maximum operating wave height, see Eq. (6.3).

$$l_{e,\min} = h_{o,\max} \quad (6.3)$$

Even if the balloon is able to elongate throughout the entire wave height does not necessarily mean that the pump will be able to utilize the wave height fully. The pump will require synchronised motion with the waves in heave to achieve its full potential. The principle for how the pump mechanism could operate as desired is twofold.

6.2.1 Pump operating principle 1

The first suggestion is to design the pump with the balloon as thick-walled. With this design, the weight forces on the balloon will elongate the balloon approximately 100 per cent in air. In which case, the buoyancy module is designed small and rests upon the sea surface with a small draft.

The pump will operate in optimal conditions by having the buoyancy module floating upon the sea surface relatively lightly⁶. When the wave surface goes up, so does the buoyancy module with ease. However, the buoyancy module must be designed heavy enough to ensure that it also goes down with the wave surface, to ensure a synchronised motion.

To some extent, this principle disregards the Eigen-frequency of the spring system. Another benefit of this principle is that the buoyancy module can be designed relatively small, but this in turn may require a great volume of rubber to produce a single balloon. However, more flexible rubber requires less original balloon length, thus more flexibility demands less material.

Even though this system does not base its functionality on resonant motion, the design still needs to acknowledge the correlation between the Eigen-frequency of the pump and the heave frequency of the waves.

6.2.2 Pump operating principle 2

The second suggestion for how the pump should operate is to design the pump with the balloon as thin-walled. In this case, the weight forces on the balloon will elongate the balloon far beyond 100 per cent in air, but will be kept in equilibrium by the buoyancy force from the submerged volume of the buoyancy module.

The pump will operate in optimal conditions by designing the pump to have an Eigen-frequency close to the heave frequency of the waves. The resonant motion ensures that when the wave surface goes up, so does the buoyancy module. When the wave surface goes down, again, so does the buoyancy module. Ideally, this resonant motion will give the pump in perfect swell waves a reliable continuous pumping motion.

A benefit of this principle is that the balloon can be designed much cheaper, by not having it as the primary load bearer. This also means that the buoyancy module must be designed much larger to procure enough buoyancy. The buoyancy module must also be designed with enough compartment space to make the pump able to change its Eigen-frequency appropriate to a wide range of wave frequencies.

Another disadvantage of this principle are the numerous varying factors that influence the Eigen-frequency of the pump during a wave period, such as:

- Amount of fluid within the balloon - Mass [kg]
- Fluid flow restriction into and out of balloon - Damping [kg/s]
- Non-linear spring behaviour caused by varying stiffness of rubber materials - Spring constant [kg/s²]

⁶ The buoyancy module floats lightly means it is kept afloat with a spring force larger than the buoyancy force.

In addition to these factors are also hydrodynamic added mass and water line area. The combination of these factors complicates the analytical calculations to project an accurate model. The best way to obtain sufficient data to procure an accurate model of the spring system would be through prototype testing, both scaled and full-scale.

6.3 PUMP DESIGN PROPOSAL

The proposed design from which the theoretical efficiency is calculated is based on the second operational principle. The measurements given here are somewhat limited to those required to determine a theoretical efficiency.

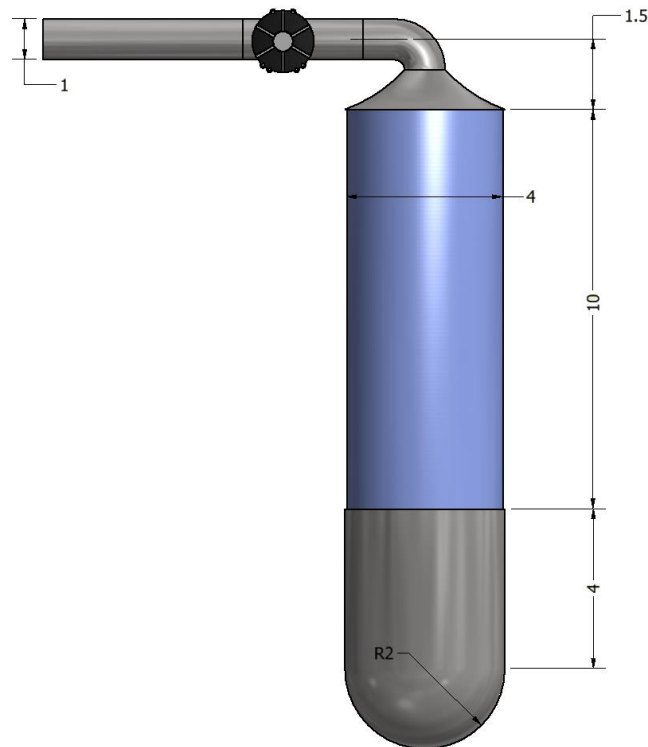

Figure 32. Measurements of pump design proposal

The measurements shown in Figure 32 are given in metres. Clamps are excluded here and in the calculations in the following.

6.4 THEORETICAL EFFICIENCY

This section presents the theoretical efficiency of the system for producing electric energy with a closed-system pumping mechanism. The calculations assume ideal conditions for the pump with the measurements described in the previous section. Instead of describing a defined maximum efficiency, it is determined more accurate to describe the efficiency for a range of possible sea states.

The wave period of swell seas lie primarily in the range between 6 and 16 seconds. The maximum wave height for the sinus-curved sea was determined at ten metres. Based on these values, a selection of sea states were picked out for calculation and comparison, see Table 3.

Development of a Wave-Driven Pump for Energy Production

Table 3. Feasible swell sea states

Wave height (H)	<1	1	2	3	4	5	6	7	8	9	10	[m]
Wave period (T)	6	7	8	9	10	11	12	13	14	15	16	[s]

The AWACE Production unit does not simply increase its productivity with increased wave height. Instead, the unit has increased productivity when the relationship between the wave height and wave period increases. The wave system effectiveness, η_w , is based on the above table and classified in Table 4.

Table 4. Wave system effectiveness classification

$\eta_w = \frac{H}{T}$	Description
$\eta_w \leq \frac{1}{3}$	Low
$\frac{1}{3} < \eta_w \leq \frac{1}{2}$	Mean
$\frac{1}{2} < \eta_w \leq \frac{2}{3}$	High
$\frac{2}{3} < \eta_w$	Very high

The theoretical efficiency of the system is calculated in the following. In the calculations, the wave system of five-metre waves and ten seconds period is used as example values. The assumed hydraulic fluid density is given in Eq. (6.4)

$$\rho_o = 869 \left[\frac{kg}{m^3} \right] \quad (6.4)$$

The balloon's internal diameter is assumed constant at four metres, see Eq. (6.5).

$$d_b = 4[m] \quad (6.5)$$

Eq. (6.6) calculates the cross sectional area of the balloon corresponding to a diameter of four metres.

$$A_b = \frac{\pi}{4} \cdot d_b^2 \quad (6.6)$$

$$A_b = 12.6[m^2] \quad (6.7)$$

The turbine pipe is one metre in diameter, see Eq. (6.8).

$$d_{tp} = 1[m] \quad (6.8)$$

The corresponding cross sectional area of the turbine pipe is given by Eq. (6.9).

$$A_p = \frac{\pi}{4} \cdot d_p^2 \quad (6.9)$$

$$A_p = 0.785 [m^2] \quad (6.10)$$

The five-metre wave height equals five metres of elongated balloon length. Assuming synchronised motion between the waves in heave and the pump in heave. Eq. (6.11) expresses the five metres of elongated balloon retracting in half the wave period.

$$v_1 = \frac{H}{\frac{T}{2}} = 2 \cdot \eta_w \quad (6.11)$$

$$v_1 = 1 \left[\frac{m}{s} \right] \quad (6.12)$$

Eq. (6.13) gives the volume flow rate into the funnel with the given cross-sectional area.

$$Q_1 = A_b \cdot v_1 \quad (6.13)$$

$$Q_1 = 12.6 \left[\frac{m^3}{s} \right] \quad (6.14)$$

The fluid through the funnel to the turbine assumes incompressible, unrestricted and steady flow with no leakage. The continuity equation is thus applicable, see Eq. (6.15) and (6.16).

$$Q_1 = Q_2 \quad (6.15)$$

$$A_b \cdot v_1 = A_p \cdot v_2 \quad (6.16)$$

Rearranging the above equation results in Eq. (6.17) to express the fluid flow rate into the turbine.

$$v_2 = \frac{A_b}{A_p} \cdot v_1 = \frac{A_b}{A_p} \cdot 2\eta_w \quad (6.17)$$

$$v_2 = 16.1 \left[\frac{m}{s} \right] \quad (6.18)$$

Fluid energy comprises three components of energy. These components are *pressure energy*, *kinetic energy* and *potential energy*. When the buoyancy module travels upwards, it is assumed that nearly all of the fluid's energy is transformed into kinetic energy. Based on the formula for kinetic energy, the dynamic pressure of the fluid into the turbine is given by Eq. (6.19).

$$P_{dynamic} = \frac{1}{2} \cdot \rho_o \cdot v_2^2 \quad (6.19)$$

$$P_{dynamic} = 113 [kPa] \quad (6.20)$$

The dynamic pressure can be expressed in terms of pressure head, see Eq. (6.21).

$$P_{head} = \frac{P_{dynamic}}{g \cdot \rho_o} \quad (6.21)$$

$$P_{head} = 13.2[m] \tag{6.22}$$

The volume flow rate into the turbine is the same as the volume flow rate out of the balloon. The conditions of the fluid travelling into the turbine can be charted in a “rule of thumb” chart of applicable turbines and likely production capability, see Figure 33.

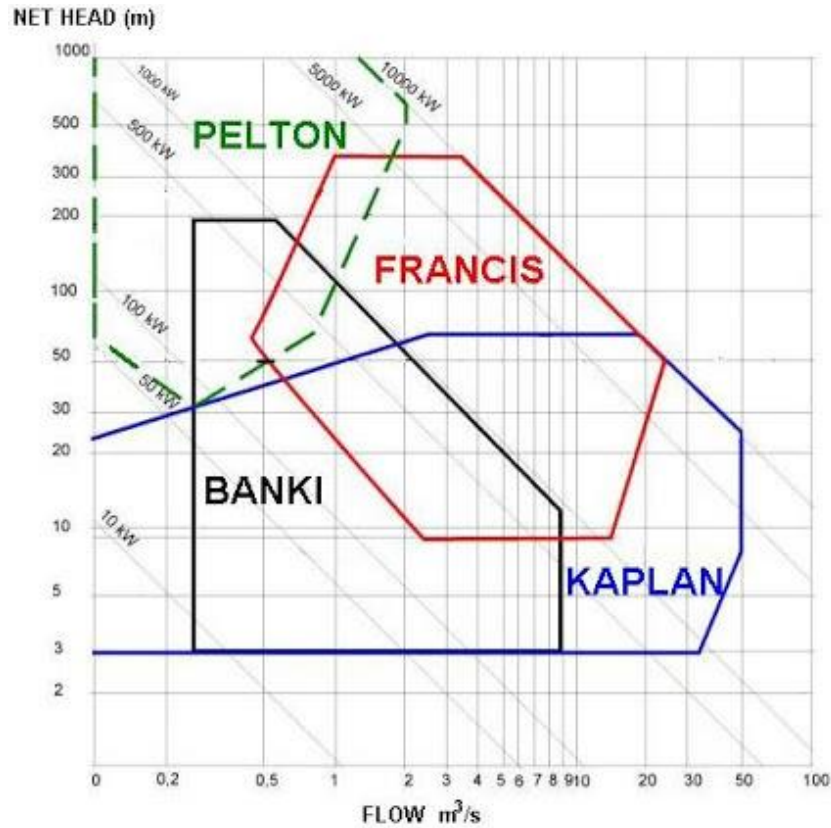

Figure 33. Hydraulic turbine selection chart and likely production rate (NaturEnergia, 2015)

The flow characteristics reveal from the chart that the Francis turbine is potentially applicable, but a more robust solution is the Kaplan turbine. However, since the fluid’s energy is dynamic energy, the system would most likely require an impulse turbine, while the Kaplan turbine is a reaction turbine. Yet to simplify, the calculations further assumes the Kaplan turbine applicable and Eq. (6.23) expresses the approximate expected power generated through this turbine with the given flow characteristic’s.

$$P_{pump} = 1.8[MW] \tag{6.23}$$

It is assumed that the start and stop of the turbine has negligible effect on the productivity. It is also assumed that the turbine only rotates when the balloon retracts, and not when it elongates. The effective power generation is then halved, see Eq. (6.24).

$$P_{pump,e} = 0.9[MW] \tag{6.24}$$

In contrast, the Pelamis sea snake with three generators has a total output of 2.25 [MW]. Furthermore, the world’s largest wave energy park outside Sotenäs will supply, once fully operational with 420 units, a total output of 10[MW].

Eq. (6.25) expresses the yearly effective pump power if the system works in the given sea state for a whole year, which is 8760 hours per year.

$$P_{pump,yearly} = P_{pump,e} \cdot 8760 \left[\frac{h}{year} \right] \quad (6.25)$$

$$P_{pump,yearly} = 7884 \left[\frac{MWh}{year} \right] \quad (6.26)$$

The average Norwegian family-household used approximately 20,000 [kWh] electric energy per 2012 (SSB, 2014). This means that a single AWACE Production pump is able to provide the yearly electric energy demand for 394 Norwegian family-households. In which case, the jack-up platform with the 3-balloon setup as shown in Figure 25 would theoretically produce the energy corresponding to the demand of 1182 family households.

In terms of wave energy utilization, the utilization of the wave section passing the balloon with same width as the internal diameter of the balloon can be calculated by Eq. (6.27).

$$\eta_u = \frac{P_{pump,e} \cdot T}{\frac{1}{8} \cdot \rho_{sw} \cdot g \cdot H^2 \cdot L \cdot d_b} \quad (6.27)$$

Eq. (6.28) expresses the utilization factor while the wavelength is given by $L = \frac{g}{2\pi} \cdot T^2$ and the seawater density is assumed to 1025[kg/m³].

$$\eta_u = 0.459 \quad (6.28)$$

The calculations state that the pump can theoretically produce electric energy equal to 45.9 per cent of the wave energy passing under the balloon.

The calculation process was run for the swell seas highlighted in Table 3. An overview of the sea state hydraulics is shown in Table 5. The values in the “Effective Power” column in the table below are approximations from the projection chart of Figure 33.

Table 5. Sea state description and hydraulics overview for balloon with 4[m] diameter

Wave height	Wave period	Effectiveness	Descriptive term	Volume flow rate	Pressure head	Effective Power
2	8	0.250	Low	6.30	3.30	0.110
2	7	0.286	Low	7.20	4.30	0.150
2	6	0.333	Low	8.40	5.80	0.220
5	12	0.417	Mean	10.5	9.10	0.375
5	11	0.455	Mean	11.4	10.8	0.575
5	10	0.500	Mean	12.6	13.2	0.900
9	15	0.600	High	15.1	18.8	1.40
9	14	0.643	High	16.2	21.6	1.70
9	13	0.692	Very High	17.4	25.0	2.10
[m]	[s]	[m/s]	-	[m ³ /s]	[m]	[MW]

Development of a Wave-Driven Pump for Energy Production

Even though the possible hydraulic conditions indicate the Kaplan turbine as appropriate does not mean that a single sized turbine is able to handle the range of conditions described above. The turbine and turbine pipe should be designed in accordance with the expected/dominating sea state of the area of interest. Alternatively, the pipe system could include alternate flow routes, thus directing flow into the appropriate turbine according to the acting sea state. The results also assumes that the Kaplan turbine is able to make use of the flow rate and pressure and that it is suitable for a pipe of one metre in diameter.

The calculation process was repeated with the diameter of the balloon changed from four to five metres to obtain a perspective of its significance in contribution.

Table 6. Sea state description and hydraulics overview for balloon with 5[m] diameter

Wave height	Wave period	Effectiveness	Descriptive term	Volume flow rate	Pressure head	Effective Power
2	8	0.250	Low	9.80	8.00	0.375
2	7	0.286	Low	11.2	10.4	0.500
2	6	0.333	Low	13.1	14.2	0.875
5	12	0.417	Mean	16.4	22.1	1.68
5	11	0.455	Mean	17.8	26.3	1.90
5	10	0.500	Mean	19.6	31.9	2.50
9	15	0.600	High	23.6	45.9	4.00
9	14	0.643	High	25.2	52.7	5.00
9	13	0.692	Very High	27.2	61.1	>5.00
[m]	[s]	[m/s]	-	[m ³ /s]	[m]	[MW]

Summing up the calculation process, the important factors to increase the effective power output are:

1. Increasing $\frac{A_b}{A_p} \left[\frac{m^2}{m^2} \right] \Rightarrow$ Increases dynamic pressure $[Pa] \Rightarrow$ Increases power $[W]$
2. Increasing $A_b [m^2] \Rightarrow$ Increases volume flow rate $\left[\frac{m^3}{s} \right] \Rightarrow$ Increases power $[W]$

From the values of Table 5 and Table 6, an overview of the relation between wave effectiveness and yearly production can be seen in Figure 34 below. The energy production values are in terms of average Norwegian family-households using 20[MWh] per year. The values show an approximation of electric energy that a single AWACE Production pump would supply during 100 per cent operation per year with the given effectiveness (wave height/wavelength).

There is a significant increase in electric energy production by increasing the diameter of the balloon. Given that the last column for the five-metre balloon diameter approximation is out of bounds, the graph shows that the productivity increases approximately threefold by increasing the balloon's diameter from four to five metres.

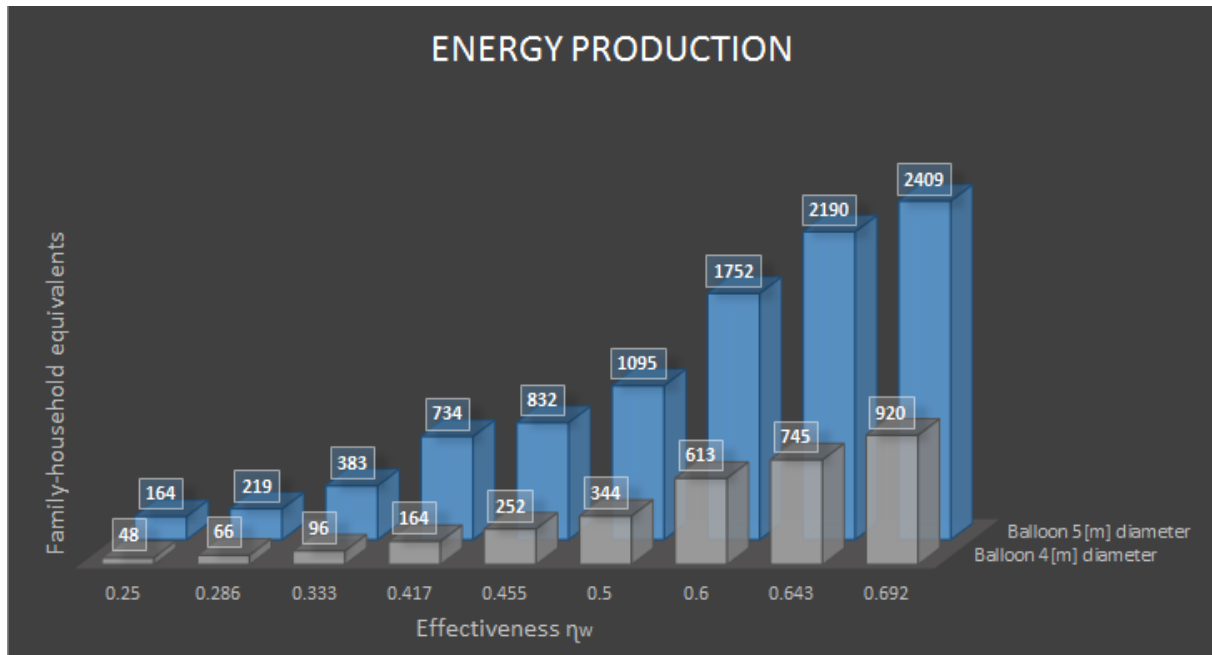

Figure 34. Yearly electric energy production

Yet one has to address flow restriction when dimensioning for optimal productivity. Larger area/area ratio reduces transition and smooth flow. Larger funnel height can grant a smoother flow transition, but increases hydrostatic pressure in the balloon, see next chapter for details. However, this issue of hydraulics can be its own thesis. Therefore, the dimensions of Figure 32 are only based on perceptive assumptions.

Computational fluid dynamics (CFD) analyses can be used to establish the optimal production design. The optimal design may give even better results than those of Table 6, and may give worse results than those of Table 5. However, running this type of analysis requires a thorough understanding of how the pump behaves during wave interaction to procure accurate simulations. The next chapter covers the development and testing of a prototype to further the understanding for how the pump operates in a relevant environment, which may strengthen the assumptions for a new round of establishing the production potential of this concept in the future.

Yet with the results from this chapter, it is possible to conclude that there are in fact a major energy production potential to this concept. Even if this potential is subject to large uncertainties due to the numerous and complex assumptions made. Nevertheless, this potential can give the inventor a chance to obtain government funding for continued development after thesis completion, but can also entice a company to buy the idea at a conceptual stage.

CHAPTER 7 – PROTOTYPE TESTING

The previous chapter covers an explanation regarding how the pump mechanism is supposed to operate with a wave-synchronised motion. This mode of operation forms the basis for estimating the electric energy production potential. However, perceptive thinking cannot alone support the assumption that the pump in reality will deliver on its promise. The pump's behaviour in the wave zone should be established scientifically, either through simulations or through testing with a prototype, to further determine the credibility of the concept. This chapter covers the design and testing of a prototype of the pump.

7.1 PROTOTYPE DESCRIPTION

A prototype of the pump mechanism was by the student designed and built with the intent to materialize the theoretical assumptions of the pump's operability. The prototype, see Figure 35, has a vague resemblance of the pump's appearance, but comprises the same modules and features.



Figure 35. Inventor model of the prototype

The buoyancy module was built as a square box instead of the cylindrical shaped module shown in Figure 32. The box shape was implemented with the intent to obtain more conclusive results to some of the tests conducted. The alternative shape is expected not to have significant impact on the results of the other tests conducted as part of this thesis. However, for future detailed testing it is recommended to use a prototype that is of the same shape as the full-scale unit and

Development of a Wave-Driven Pump for Energy Production

uniformly scaled. The buoyancy module is hollow and include a sealable opening to convey fluid into and out of the module.

The platform hull is a simple plate supported by stiffeners to reduce deflection. On top of the plate is a frame supporting a tube that conveys the fluid forced out of the balloon. The tube or “measuring tube” is the key component to measure the height of the displaced fluid. The tests conducted comprises four sizes of measuring tube: $\frac{1}{2}$ ”, $\frac{3}{4}$ ”, 1” and 1 $\frac{1}{4}$ ”.

The balloon connects to the plate and buoyancy module by hose clamps that fix the balloon in place between cylindrical pieces of steel.

Most of the prototype’s components are of constructional steel, S355. The exceptions are the nuts, bolts and washers, standard hydraulic components, the plastic measuring tube and the rubber balloon. Figure 36 show an exploded view of the prototype revealing all the comprising components.

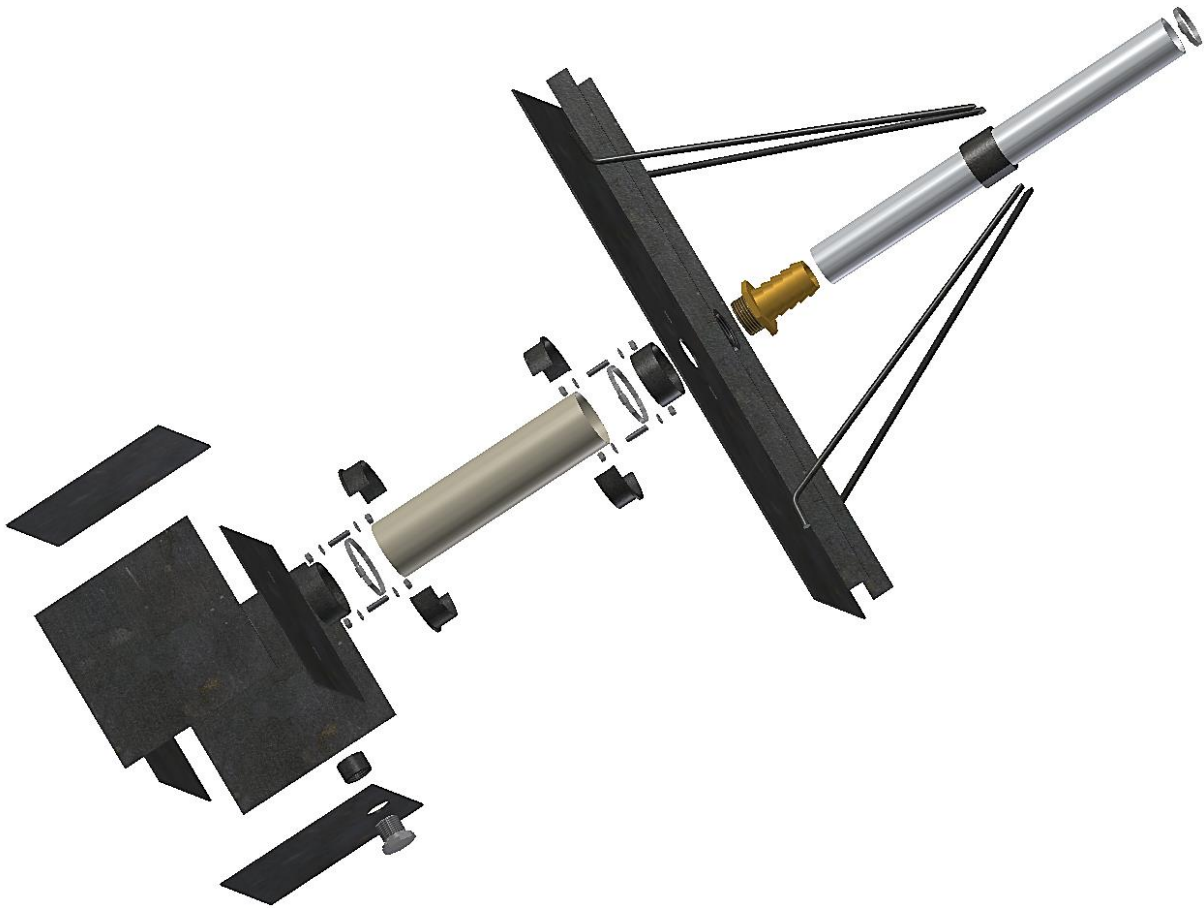

Figure 36. Inventor model of the prototype in exploded view

The technical drawings of the prototype are attached in Appendix E. The drawings include a list of components, detailed description of the individual components and an assembly description to explain sufficiently the constructional procedures so that an average-skilled artisan may repeat the work.

7.1.1 Buoyancy module motions

While floating on the water surface, the BM experience six types of motions during wave interaction. These motions are referred to as degrees of freedom (DOF) and are classified into translational and rotational motions. The translational motions are surge, sway and heave, while the rotational motions are roll, pitch and yaw. Figure 37 shows the DOF of the BM. For the tests conducted in the wave pool, surge is the translation aligned with the direction of the wave's propagation.

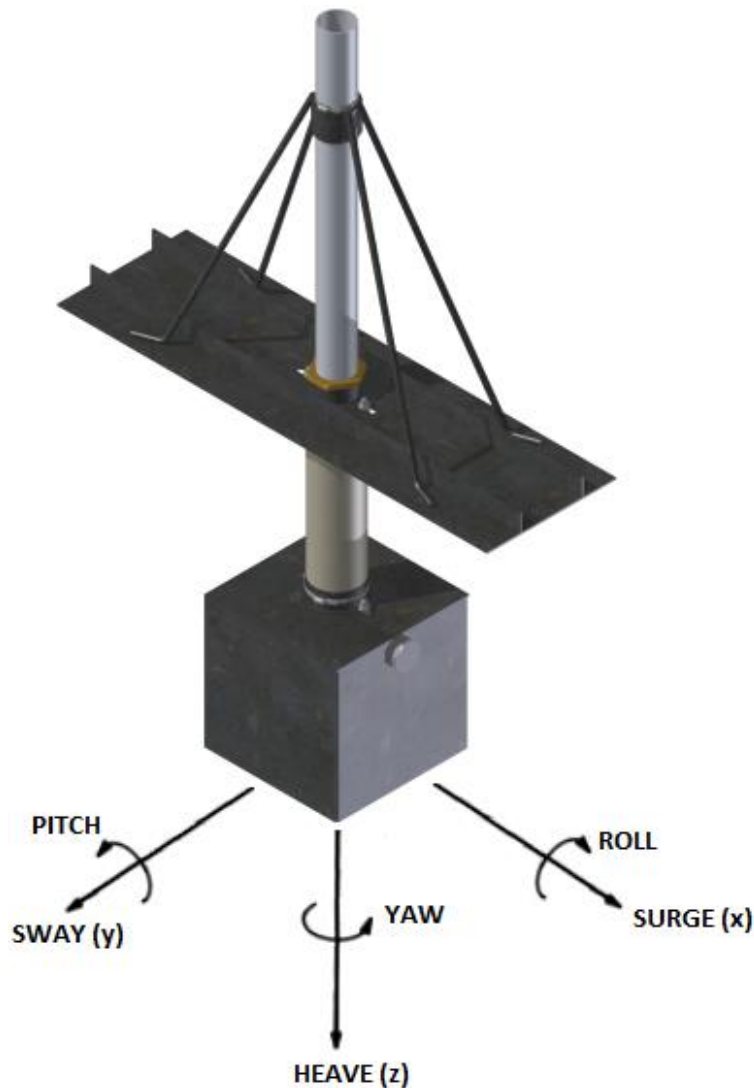

Figure 37. The buoyancy module's six degrees of freedom

The motions of the BM induces stresses on the balloon, particularly in the area directly above the bottom clamp. The heave motion creates tension stress, while the yaw motion creates torsional stress throughout the balloon. Sway and surge creates shear and bending stresses, while pitch and roll causes bending induced stress.

Waves- and therefore the motion-induced stresses are cyclic, which means fatigue damage is an important design aspect to the life expectancy of the AWACE Production pump. Limiting these motions is therefore important to the viability of the concept.

7.1.2 Balloon characteristics

The prototype's balloon could have been special-made. However, the projected cost of the casting mould alone was 25,000 [NOK]. This price exceeded the budgetary limit of this project, so the alternative was using an existing product. The component functioning as the balloon is a rubber membrane for containing earth samples for geological surveys. The prototype's design was based on this component.

The cost of the rubber membrane was less than 100 [NOK] each, but there were no description or data of its material properties. The solution was to procure several of these and obtain the data through tensile tests. Figure 38 is a picture of a balloon in the university's tensile test machine.



Figure 38. Balloon tensile test setup

Normally, this type of testing would require numerous test samples to procure a reliable conclusion of the result. The tensile tests conducted in this project, however, concerned only three samples. The results of the tensile tests are graphically displayed in Figure 39. Note that the test samples never broke during loading, the vertical line at the end of each curve marks where the tests were manually terminated.

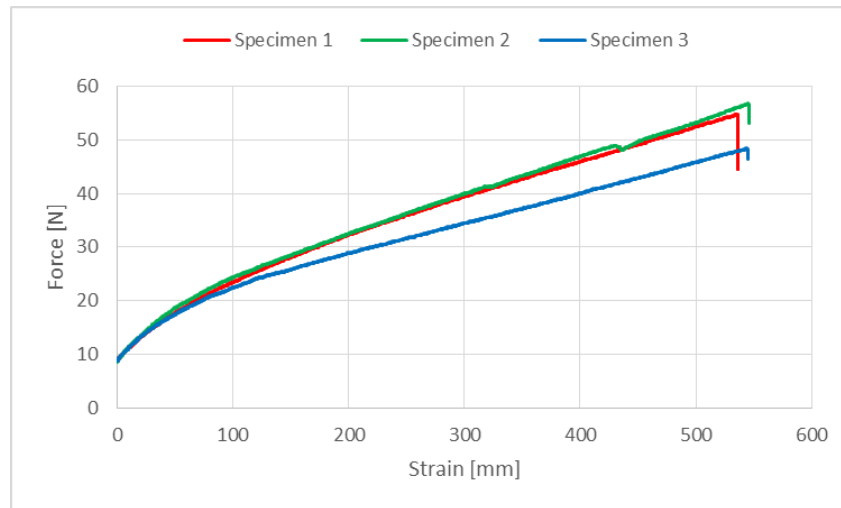

Figure 39. Test results of balloon tensile test

From the above graph, it can be shown that Specimen 1 and Specimen 2 show strong resemblance. Specimen 3, however, have a significant deviation from the other two test samples. There is reason to believe that the bottom clamp holding the balloon in place lost some of its grip on the balloon during the early stage of loading. This would also explain the altered curve. For this reason, Specimen 3 is excluded and the average of the first two specimens is used to describe the stress-strain curve of the material.

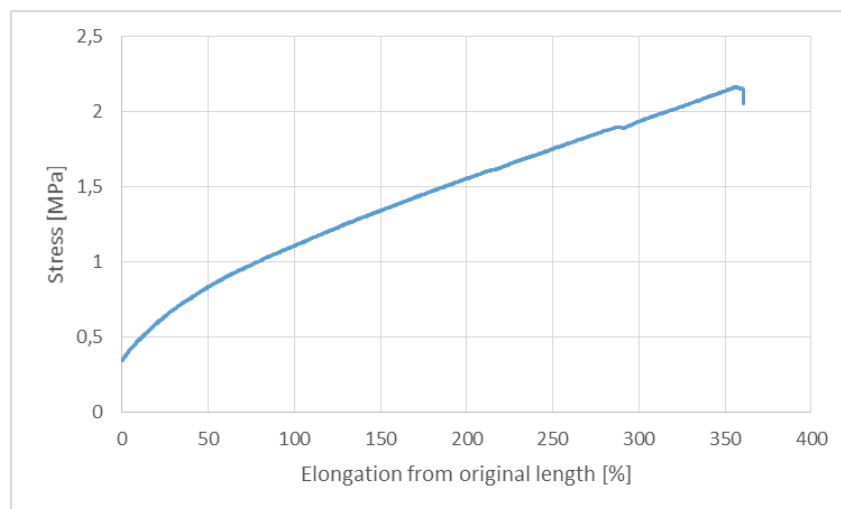

Figure 40. Average stress-strain curve of the balloon

Figure 40 shows the stress-strain curve of the rubber balloon based on the test results of Figure 39. The stress is calculated as the immediate force on the original cross-sectional area of the balloon, while the strain is expressed in terms of per cent elongation from the balloon's original length of the unclamped section (163 millimetres). The subjective accuracy of the graph is plus/minus four per cent elongation based on the method of which the balloon was constrained and variation from the first and second specimen.

There is a noticeable disturbance in the curve at 290 per cent elongation, likely caused by grip loss. The disturbance is disregarded since the balloon will not experience such elongation during prototype testing.

7.1.3 The pump's Eigen-period

The pump mechanism is designed initially not to operate in resonance, but to have synchronous motion with the waves in heave through vertical force variations from buoyancy. It is still valuable to recognise the prototype's natural frequency so that resonant behaviour can be brought forth during testing and be visualised to gain further knowledge of the pump's behaviour during wave interaction. This section covers the estimation of the prototype's natural heave period.

The water density at the test facility is assumed at 1000 kilograms per cubic metre, see Eq. (7.1).

$$\rho_w = 1000 \left[\frac{kg}{m^3} \right] \quad (7.1)$$

Eq. (7.2) gives the waterline area of the partially submerged buoyancy module.

$$A_w = 0.0231 \left[m^2 \right] \quad (7.2)$$

Based on this value, Eq. (7.3) gives the spring stiffness caused by the waterline area surrounding the buoyancy module.

$$k_w = \rho_w \cdot A_w \cdot g \quad (7.3)$$

$$k_w = 227 \left[\frac{kg}{s^2} \right] \quad (7.4)$$

The spring stiffness of the rubber material of which the balloon is made decreases with increased applied load. The stiffness curve is graphically displayed in Figure 41 and was developed from the stress-strain curve of Figure 40.

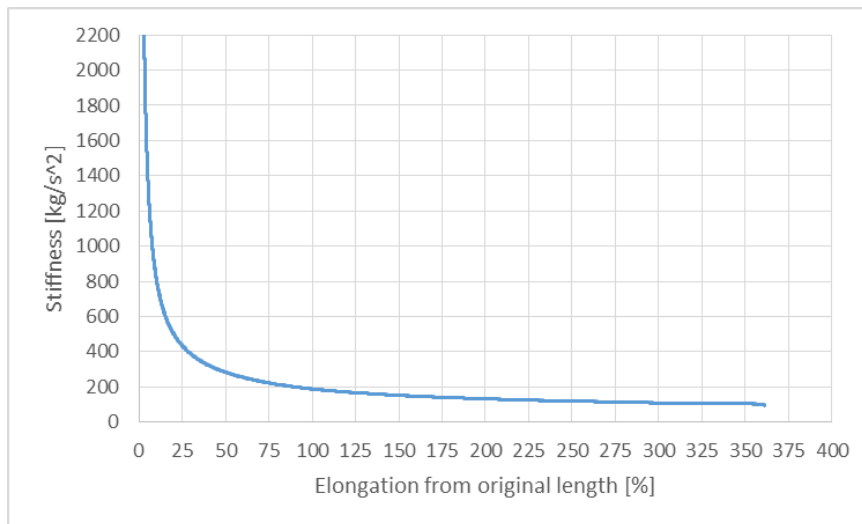

Figure 41. Balloon spring-stiffness curve

The material's stiffness changes dramatically with load increase as seen in the above figure. The stiffness is approximately halved from three to ten per cent elongation. For the calculation example, the reference value of balloon stiffness is at 100 per cent elongation and given in Eq. (7.5).

$$k_b = 188 \left[\frac{kg}{s^2} \right] \quad (7.5)$$

Eq. (7.6) expresses the mass of the pump and includes the mass of the buoyancy module, balloon and related equipment.

$$m_p = 2.40 [kg] \quad (7.6)$$

The hydrodynamic added mass caused by the submerged buoyancy module is assumed as the mass of water in a volume equal to a half cylinder with the same diameter and length as the bottom of the buoyancy module, see Eq. (7.7).

$$m_a = \rho_w \cdot \frac{\pi}{8} \cdot 152 [mm]^3 \quad (7.7)$$

$$m_a = 1.38 [kg] \quad (7.8)$$

While assuming the balloon's internal diameter as constant, Eq. (7.9) expresses the mass of water contained within the balloon when it is elongated 100 per cent.

$$m_c = 0.733 [kg] \quad (7.9)$$

The Eigen-period of the pump at 100 per cent elongation is estimated from Eq. (7.10).

$$T_h = 2\pi \sqrt{\frac{m_p + m_a + m_c}{k_w + k_b}} \quad (7.10)$$

$$T_h = 0.641 [s] \quad (7.11)$$

The calculation process was repeated for the various stages of elongation. The resulting period curve is displayed in Figure 42.

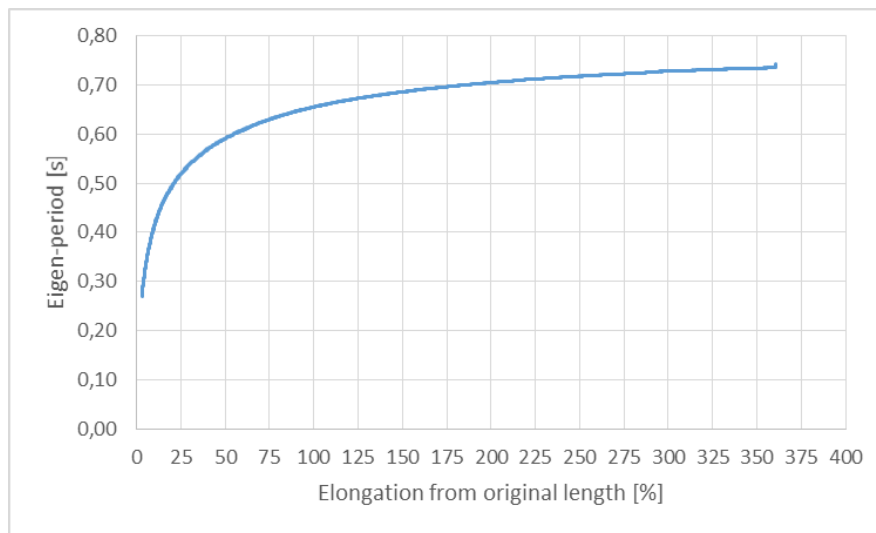

Figure 42. The Eigen-period of the pump at various stages of balloon elongation

The above graph shows that the pump's natural period in heave varies from 0.27 seconds at three per cent elongation to 0.73 seconds at 350 per cent elongation.

7.1.4 The balloon's circumference

When the balloon's unclamped section is elongated 100 per cent, the balloon experiences multiple loads and stresses which on an elastic material such as rubber causes substantial deformation. This deformation cannot be determined analytically through "regular" strain formulas since rubber is a viscoelastic material. Instead, *hyperelastic models* describe the material by assuming it behaves like a non-linear elastic, isotropic and incompressible material independent of strain rate (Bower, 2008).

When the balloon is elongated, the diameter decreases. When the balloon contains water, hydrostatic pressure causes the diameter to increase. Ideally, the strain on the balloon would be determined prior to building the prototype. Unfortunately, hyperelastic models require various material parameters, which were not recovered for the balloon component. The best option was therefore to build the prototype, then test and observe the deformation.

Figure 43 shows the diametrical change in the balloon during 100 per cent elongation while containing 0.7 litres of water. The maximum outer diameter of the balloon was measured at 75 millimetres, while the smallest diameter was measured at 39 millimetres.



Figure 43. Balloon bulging at 100 per cent elongation and containing 0.7 litres of water

The volumetric change inside the balloon is of vital importance for the efficiency of the pump. One of the defining assumptions in Chapter 6 was the assumption that the balloon's internal diameter would remain constant. In fact, the bulging of the balloon during testing proved so influential that in order to get decent results the balloon had to be circumferentially constrained.



Figure 44. The prototype with the balloon circumferentially constrained with shoelaces

Several methods to constrain the balloon's circumference were tried out. Such as compression bandage and various types of rubber bands. Proving the most efficient method, however, was tying shoelaces around the balloon to constrain its circumference, see Figure 44.

7.2 PURPOSE OF TESTS

The AWACE Production pump and especially the balloon experience far more loads and load effects than those briefly mentioned in the previous section. Table 7 lists the effects that the pump is prone to experience in full-scale operation.

In addition to the individual loads, the combinations of loads must also be accounted for. Even though computational simulations may prove a vital tool in determining the required design for load resistance, on a stand-alone basis, they may not be sufficiently accurate or even misleading. In addition, while developing something new, engineers must acknowledge the likeliness of unforeseen scenarios and unpredicted loads and load combinations. For these reasons, state regulations are recommending and may also require scaled or even full-scale test models, from which observations are acquired. The combination of both real observations and theoretical calculations thus forms the basis from which the product is designed.

Development of a Wave-Driven Pump for Energy Production

Table 7. Loads and effects on the AWACE Production pump

Category	Effects				
Permanent	Weight of balloon	Weight of buoyancy module (BM)	Weight of clamps and other equipment	Clamp forces	
Variable	Weight of fluid contained in balloon	Weight of fluid contained in BM	Damping from pumping fluid in/out of balloon	Hydrostatic pressure inside balloon	DAF ⁷
Environmental	Wave drag forces	Wave lift forces	Wind load	Current load	
Deformational	Longitudinal strain	Hoop strain	Temperature variations	Balloon bending	Balloon torsion
Accidental	Impact load from floating objects	Impact load from dropped objects off platform	Collision among pumps	Collision between pump and platform	

Model testing may purposely vary in detail from model to model, but according to the recommended practice of DNV and NORSOK N-003 (citation) “hydrodynamic model testing should be carried out to:

- confirm that no important hydrodynamic action has been overlooked (for new types of installations, environmental conditions, adjacent structure,---)
- support theoretical calculations when available analytical methods are susceptible to large uncertainties
- verify theoretical methods on a general basis

There may also be cases where model testing is necessary to demonstrate behaviour or effects that are simply impossible to predict theoretically”. (DNV, 2010b)

For the development process of the AWACE Production pump, it is not recommended to start model testing using a full-scale model. There should be at least one small-scale model to observe and document the rough aspects of the new technology. Again, DNV roughly divides small-scale hydrodynamic model testing into four purposes:

- To determine hydrodynamic coefficients for individual structural components.
- To study the behaviour of the global system.
- To validate new numerical models.
- To examine marine operations and demonstrate functionality or special effects.

Purpose two and four in particular, but also the third purpose, reflects the intentions of the model tests performed as part of this project.

⁷ DAF is the abbreviation of dynamic amplification factor.

The tests conducted with the prototype are not just important to the design aspect, but to the development process as a whole. In order for the student to attain government funding for further development, or have even a slight chance to sell the idea post thesis, the concept should have a technology readiness level (TRL) of level three, see Table 8.

Table 8. Technology Readiness Level (Validé, 2016)

TRL	Description
1	Basic principles observed
2	Technology concept formulated
3	Experimental proof of concept
4	Technology validated in lab
5	Technology validated in relevant environment
6	Technology demonstrated in relevant environment
7	System prototype demonstration in operational environment
8	System complete and qualified
9	Actual system proven in operational environment

Upgrading the TRL of the concept further from level two can only be achieved, generally, through testing with a model. The prototype of the pumping mechanism was developed for this reason, and of those expressed by DNV.

7.3 THE TESTS

This section examines nine tests conducted in this project and closes the chapter with an overall summary of the conclusions made. Each test describes what was tested and how the test was carried out. The expectation to the result of each test is described as well. Each test closes with a discussion and conclusion of the results. Table 9 provides an overview and brief description of all the tests conducted.

Table 9. Overview of the tests conducted with the prototype

Test number	Brief description
I	Heave motion of the buoyancy module (BM) is generated by hand to prove the concept.
II	Measuring the static and dynamic height of displaced water (head) with the various tubes.
III	Validating the concept in relevant environment by testing the prototype in a wave pool.
IV	Measuring the dynamic head produced with the various tubes while the prototype operates in a wave pool.
V	Producing waves in the wave pool so large that the balloon fully retracts to determine the effects.
VI	Determining if the pump operates with a synchronised heave motion in various wave systems.
VII	Checking the validity of the Eigen-period model of Figure 42 and determining the pump's second operating principle.
VIII	Testing the effects of sloshing when the pump operates with its BM half-filled with water.
IX	Checking the effects caused by uneven draft on the BM by relocating its centre of mass.

Test I and II was conducted in the laboratory of Stavanger University, while Test III to IX was conducted in the wave pool facility belonging to Bergen University College. The compact disc of Appendix G contains ten video clips from the tests conducted in the wave pool.

7.3.1 Test I – Validating the technology in laboratory

Description

For the first test, the prototype was placed between two tables, with the support plate resting upon them. The BM was limited from elongating the unclamped balloon section further than 100 per cent by placing a closed bucket below the BM. At 100 per cent elongation, the balloon was filled with water until the waterline reached the top of the tube coupling.

The purpose of the test was to validate the concept and prove that the heave motion of the buoyancy module displaces water and thus produces hydrodynamic energy.

Expectation

Lifting the BM was expected to lead to a retraction of the balloon, causing the fluid contained within the pump to be displaced, hereby proving the concept.

Results

Lifting the BM by hand forced the contained water up the measuring tube. Figure 45 shows the before-and-after photo for the first test conducted. The left-side photo shows where the initial water line is located. The right-side photo shows the new water line location after the BM was raised.

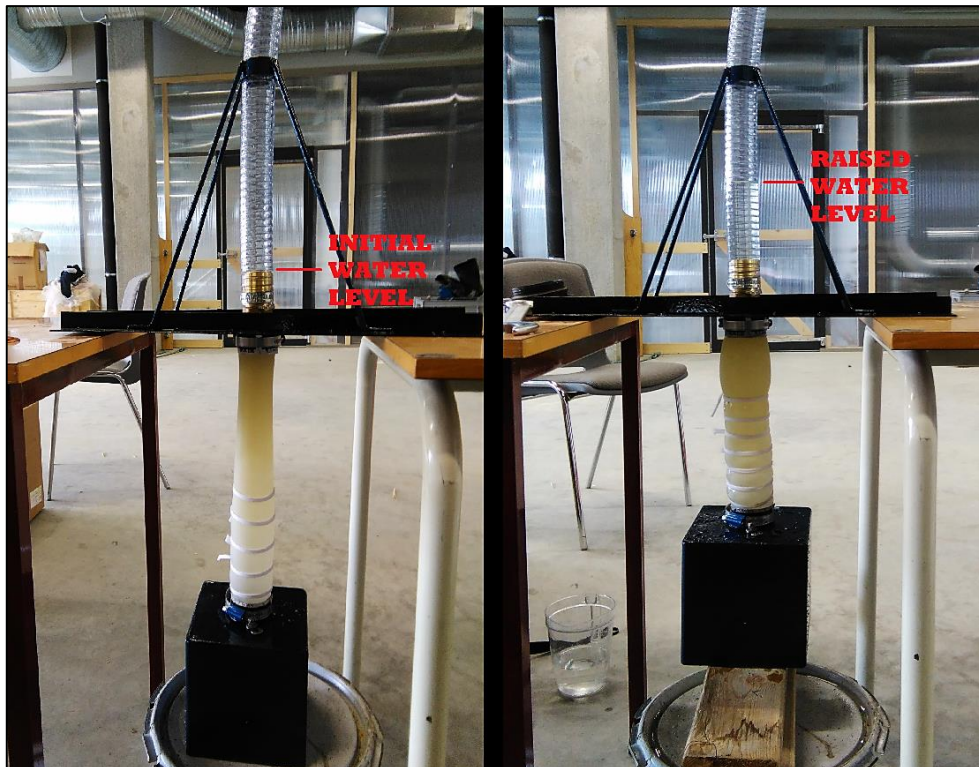

Figure 45. Water level in measuring tube as part of Test I and proof of concept

Discussion

The figure shows that retracting the balloon displaces water out of the balloon and into the tube. The raised water level increases the water column height and thus hydrostatic pressure inside the balloon, causing the balloon to bulge.

Conclusion

The test result proves the concept and hereby upgrades the TRL from two to four.

7.3.2 Test II – Determining the prototype’s productivity

Description

The second test was conducted with the same setup as in Test I. The balloon was constrained with seven strings of shoelace, as shown on the right of Figure 45. The prototype was tested with four measuring tubes, each of different diameters. Figure 45 shows the prototype comprising the measuring tube of 1 ¼”.

With each tube, the buoyancy module was lifted slowly by hand until the balloon returned to original length (no elongation). The height of the raised water level was then measured.

The raised water level was also measured in the scenario of lifting the buoyancy module quickly. The BM was lifted and lowered numerous times until the maximum head was established.

The purpose of this test was to determine the possible efficiency of the prototype in addition to determining the influence of varying heave velocity and the use of various tube sizes.

Expectations

1. The pump was expected to produce more head when the BM’s heave motion was increased, as the fluid’s kinetic energy would be converted into potential energy.
2. The pump was during ideal heave motion (heave motion created by hand) expected to be able to displace approximately the same volume of water into the measuring tube of 1 ¼” as the volume corresponding to 163 millimetres of undeformed balloon (0.326 litres).
3. Ideal heave motion with the pump was expected to produce more head with a tube of smaller internal diameter, but with smaller dynamic/static head ratio due to increased flow resistance and pipe friction.

Results

Figure 46 graphically displays the measured values from both the static and dynamic tests with the four tubes. The maximum pressure head produced by the pump was one third of a metre. The tests showed that increasing the velocity with which the buoyancy module was lifted displaced more water, thus confirming the first expectation.

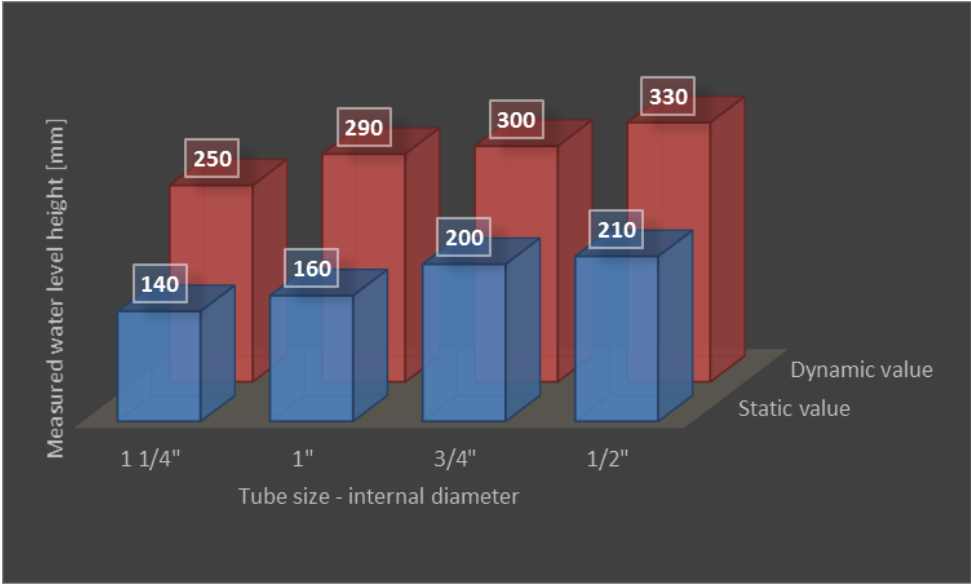

Figure 46. Maximum measured head in the various measuring tubes

The subjective accuracy of the measuring method is plus/minus three millimetres, but there is also inaccuracy due to variation in the way the balloon was constrained. From time to time, the shoelaces had to be rearranged as their position had a tendency to shift during the pumping motion. This could influence the results in the sense that the balloon may have been advantageously constrained while testing one tube size compared to another. In addition, there is inaccuracy caused by the heave motion made by hand. Therefore, the results with the various tube sizes should not be used for detailed comparisons, but only to describe tendencies.

The graph of Figure 46 shows that the measuring tube of 1 1/4" was capable of producing 0.25 metres of head in the dynamic scenario. In which case, the pump displaced 0.2 litres of water. The second expectation, however, was that the pump would be able to displace 0.326 litres. Figure 47 graphically displays the percentage of displaced volume in relation to the internal volume of 163 millimetres of undeformed balloon length from the measurements of Figure 46.

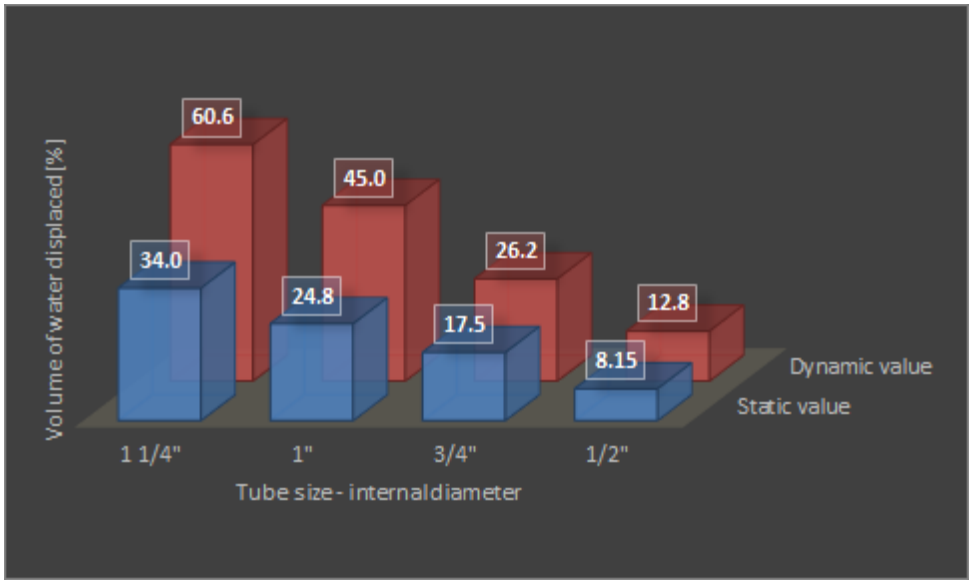

Figure 47. Displaced water volume compared to balloon's undeformed internal volume

The figure shows that the pump has a decay in displacement when using a tube of smaller diameter. The graph also shows that the prototype was not able to reach the desired efficiency, as the tube of 1 1/4" was only able to displace 60.6 per cent of its expectation.

The graph of Figure 46 shows that the water level height increases when using a tube with smaller internal diameter, as expected. It was also expected that the head ratio between the dynamic and static load case would decrease with reduced tube size. Figure 48 shows the ratio for the various tubes.

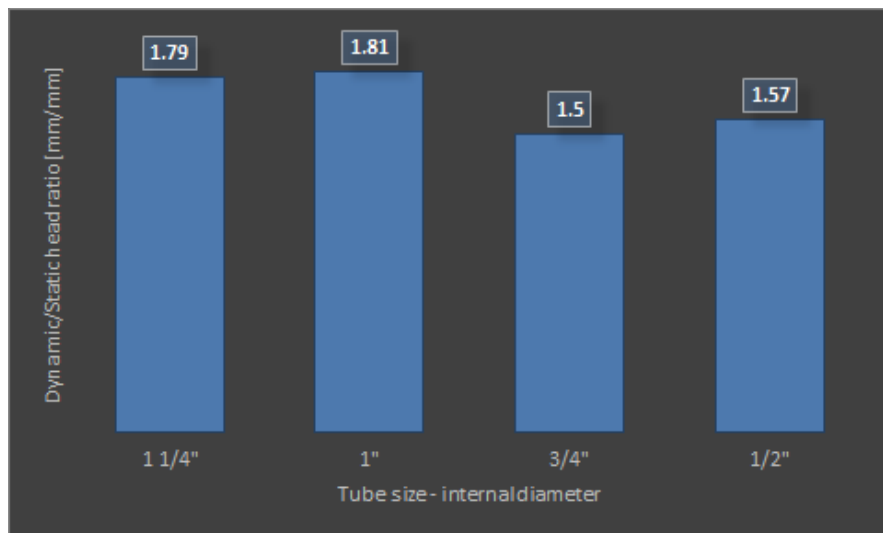

Figure 48. Ratio between the dynamic and static load case of water level height produced

By comparing the ratio for the first and second tube and comparing the third and fourth tube, the results show an effect contradictory to the expectation. However, as discussed earlier, the test results are exposed to too large inaccuracies to be used for direct comparisons. Instead, the two largest tubes are compared to the two smallest tubes. The graph of Figure 48 thus shows a tendency for ratio declination when reducing the tube diameter, thereby validating the third expectation.

Discussions

If the balloon's internal diameter had remained constant during the pumping motion, then the static displaced volume of Figure 47 would have been 100 per cent regardless of tube size. However, reducing the tube diameter increased the column height of the displaced fluid, thereby increasing the hydrostatic pressure within the balloon. The increased pressure caused an increase in the balloon's circumference. The pump's productivity is dependent on the balloon's ability to reduce its internal volume, so there is less water displacement when more of the balloon's internal volume is maintained throughout the motion.

As for the results of Figure 48, the primary contributor to the reduced ratio with reduced tube diameter is expected to be the rough transition when the water travels from a large to a smaller cross sectional area. Figure 49 is a picture showing the geometry within the tube couplings.



Figure 49. Tube couplings connected to tube of 1 1/4", 1", 3/4" and 1/2"

The figure shows the transition from large to smaller diameter the fluid must deal with when forced into the measuring tube. The two smaller couplings has a much rougher transition than the two larger couplings.

Conclusions

The results of this test does not reflect the possible efficiency of the concept as much as it is a reflection of the specific prototype's efficiency. The results were improved by constraining the balloon's circumference further, but these results were not documented. Running the same tests without the shoelaces constraining the balloon also showed that the pump was barely able to displace any water into the tube. Therefore, more than anything, the results of this test reflects the importance of reducing hoop strain, while maintaining the pump's ability to elongate.

The test also confirmed the first and third expectation to be true. Knowing the importance of the BM's heave velocity and fluid flow restriction is valuable to future design work on the AWACE Production pump.

7.3.3 Test III – Validating the technology in relevant environment

Description

In this and the following tests, the prototype was tested in the wave pool facility of Bergen University College. The prototype was installed hanging below a carriage, see Figure 50. Three threaded rods were fastened to the carriage by lock screws. The rods fixed the support plate by nut connection, encircled in the figure below. Three holes were drilled in the support plate at appropriate locations to accommodate the rods.

Duct taped to the BM is a steel angle bar of S235JR with the dimensions 30x3.5x158. The bar functions as payload and was attached with the intention to relocate the BM's centre of gravity (CoG) to its geometric centre, more on this in Test IX.

While hanging from the carriage, the balloon was elongated 50 per cent when the BM floated on the water at SWL. The measuring tube shown in the Figure 50 is the 1 1/4", while the 3/4" tube is shown in Figure 51. The waves in the pool travel from left to right.

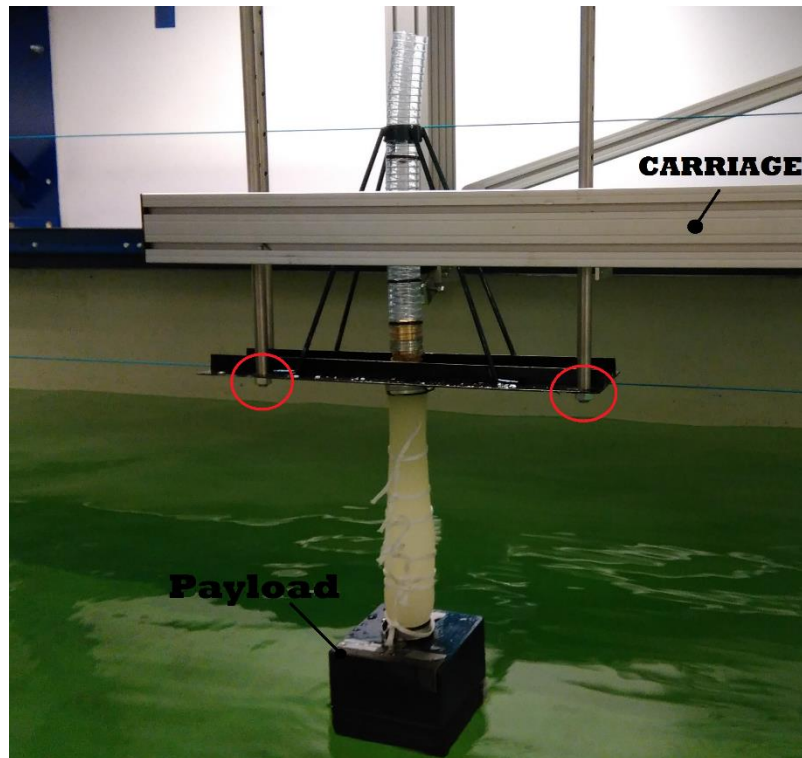

Figure 50. Picture of the prototype constrained to a carriage above the wave pool

The purpose of this test was to validate the concept in a relevant environment.

Expectations

1. The BM was expected to be carried off by the waves before returning towards original situation by the balloon's spring force.
2. The BM was also expected to be lifted and lowered in the wave zone by buoyancy.
3. During the cyclic motion, the pump was expected to displace the fluid contained within.

Results

The prototype was tested in different wave systems, varying in both peak period and height. The tests were filmed and photographed. Figure 51 displays two pictures. The picture on the left side shows the BM floating in the trough, while the picture on the right side shows the BM floating in the crest. The red lines mark where the water line is located in the measuring tube.

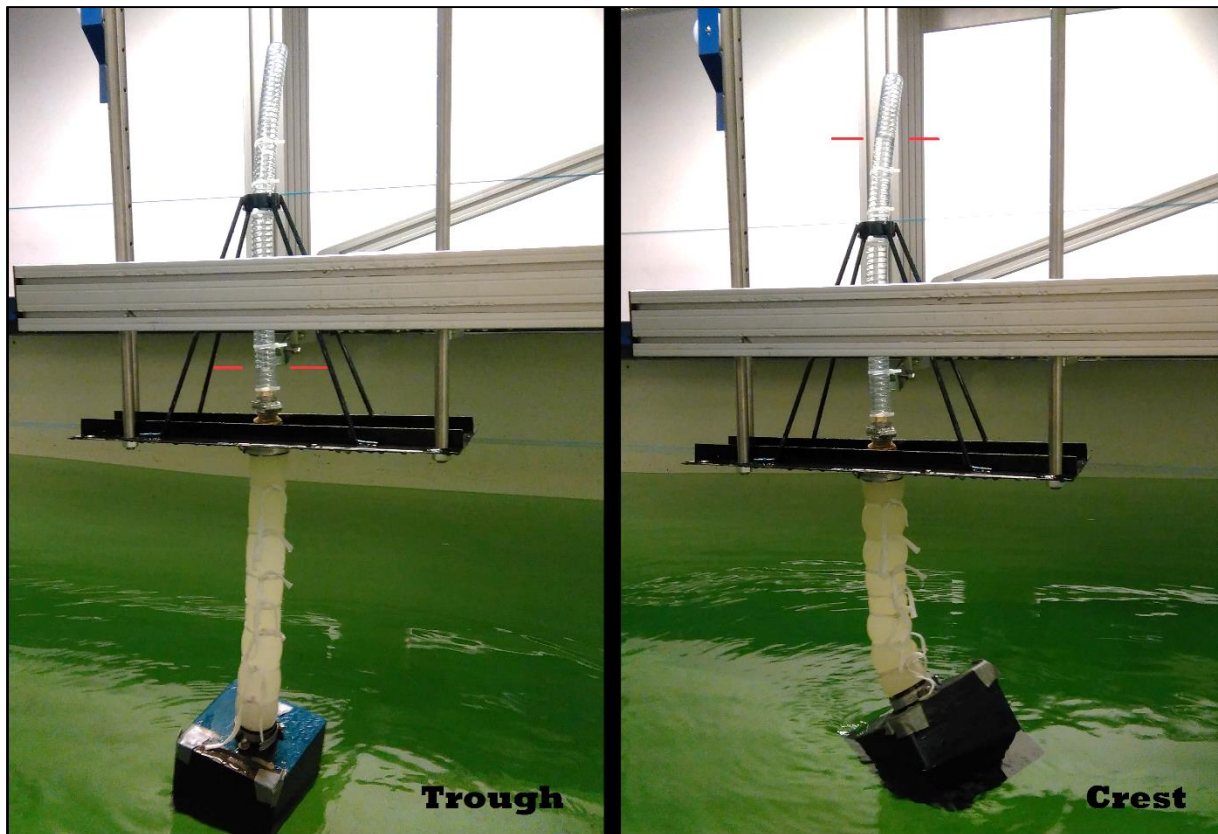

Figure 51. The pump operating with the BM in the trough and crest, respectively

Discussions

The extent to which the BM was carried off depended on both the wave height and period. The BM travelled further in higher waves, but also increasing the wave period increased the travel distance. Still, the BM always returned by the spring force in the balloon when the BM was located in and around the wave trough, and in the process, the pump displaced water. The observed behaviour validates the first expectation.

The pictures of Figure 51 together show the water is forced up the measuring tube when the BM travels upwards with the water surface. This validates the second and third expectation. The pictures also show that the increased pressure head increases hoop strain in the balloon, causing it to bulge.

Conclusion

The test validates the expectations and proves the concept in a relevant environment, hereby upgrading the TRL of the concept further to level five.

7.3.4 Test IV – Determining the prototype’s productivity in wave pool

Description

This test regards testing the prototype with the four different measuring tubes to determine its productivity in the wave system generated by the wave pool. The test was conducted with the same setup as in Test III. The balloon was constrained with seven strings of shoelace, same as shown in Figure 51.

The wave pool system was not calibrated, meaning that the input values for both wave height and frequency did not necessarily reflect the reality of the wave system. For this reason was the wave height manually measured through the glass wall, see Figure 52 for illustration.

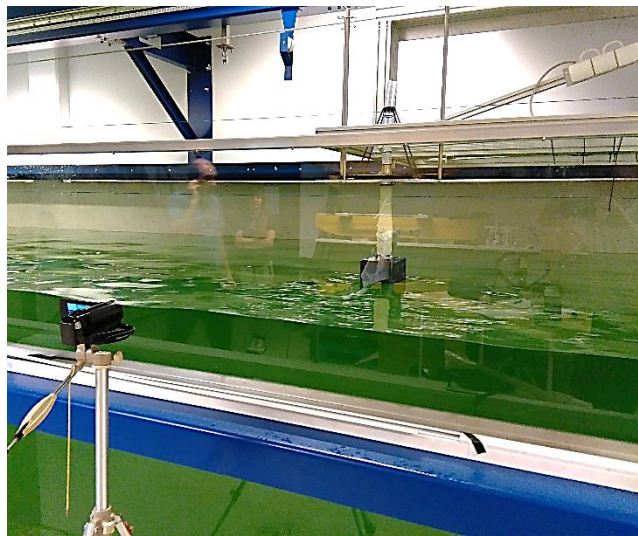

Figure 52. Picture of the prototype located behind a glass wall in the wave pool

The waves used for this test were measured to a height ranging between 160 and 170 millimetres. The input wave period was set to three seconds.

Expectation

The pump was expected to produce less head in the wave tank than with ideal loading.

Results

The same wave system was used to test the prototype with the various measuring tubes. The result is graphically displayed in Figure 53.

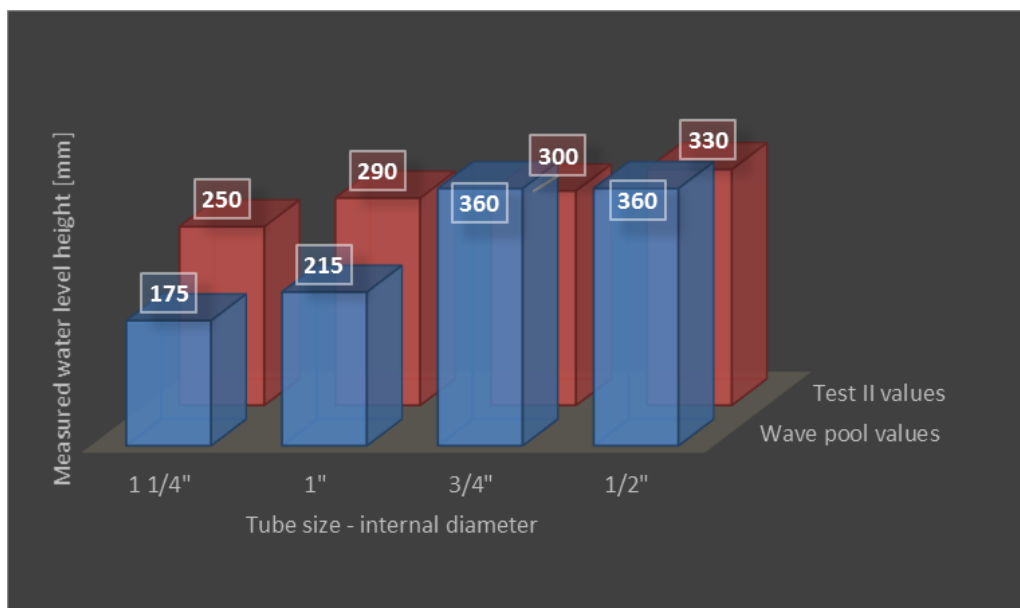

Figure 53. Head produced with various measuring tubes by hand and in wave pool

Development of a Wave-Driven Pump for Energy Production

The blue columns in the graph above shows the maximum values measured while testing in the wave pool. The subjective accuracy of the measuring method is plus/minus five millimetres.

The BM's heave motion in the wave pool is deemed more accurate in terms of consistency while testing the various tubes, than with the heave motion created by hand. The wave pool tests are therefore more appropriate for demonstrating the effects of using different tube sizes.

The results from using the two larger tube sizes validates the expectation to this test, while the results from using the two smaller tubes disproves the expectation. The results also show that using the two smaller tubes produces the same amount of head.

Discussions

The hoop strain in the balloon increases exponentially with the hydrostatic pressure. The tests showed that the balloon bulged outwards excessively while testing the pump with the two smaller tubes. So the reason the $\frac{3}{4}$ " and $\frac{1}{2}$ " tube resulted in producing the same amount of head is probably due to the combination of the tougher flow transition and the excessive circumferential deformation that occurred with this water column height. The pressure caused the balloon's internal volume to be preserved and thus preventing more water from being displaced.

Knowing that the circumferential change in the balloon increases exponentially with pressure can give a clue as to why the $\frac{3}{4}$ " and $\frac{1}{2}$ " tube produced more head in the wave pool than with ideal loading. It is likely that the balloon was better constrained while testing in the wave pool, even though the same amount of shoelace pieces were used to constrain the balloon. However, since the hoop strain increases exponentially, the constraining method was more important at 300+ millimetres of head than when testing with smaller head. The test results are therefore more susceptible to discrepancies while testing with the two smaller tubes than with the two larger tubes.

Conclusions

The results of these tests validate the expectation, but does so with high degree of uncertainty. The test results, both those obtained with ideal loading and those from the wave pool, are exposed to uncertainties and inaccuracies. Yet the results from the wave pool testing are deemed more accurate than those obtained in ideal loading. So the evaluation of efficiency of the prototype should be based on these values.

7.3.5 Test V – Checking for excessive bending in higher waves

Description

If the wave crest is higher than 50 per cent of the balloon's elongated length, then the wave continues to lift the buoyancy module after the balloon is fully retracted. This changes the balloon from a spring system with an acting spring force to a column structure exposed to pressure. When a slender structure is exposed to pressure, buckling can occur. The purpose of this test was to observe what happens when the pump operates in such high waves.

The test was conducted with the same setup as in Test III, with the 1 ¼” measuring tube. The input values for the wave system was a wave height of 200 millimetres and a period of two seconds.

Expectations

1. The balloon was expected to buckle when the wave continued upward even after the balloon was fully retracted.
2. Building on the previous expectation, the balloon was expected to buckle in the same direction as the wave’s propagation.

Results

The results were filmed with a video camera. Figure 54 shows six consecutive pictures taken from the video. Each picture is numbered in its bottom left corner.

Picture 1: The BM floats in the trough, hanging down and elongating the balloon more than 100 per cent.

Picture 2: The wave height is rising, lifting the BM and tilting it in the clockwise direction.

Picture 3: The BM floats in the crest. The balloon is fully retracted and bulges more with increased water column. There is no more available spring force in the balloon to maintain the BM’s orientation and the horizontal wave forces pushes on the bottom half of the BM, creating pitch motion.

Picture 4: The BM has to some degree followed the wave crest due to the horizontal wave forces acting on the module. The BM experiences significant pitch, which causes bending in the balloon in the area directly above the bottom clamp. The CoG and centre of buoyancy (CoB) has shifted to the left, creating a counter clockwise momentum, adding to the pitch motion.

Picture 5: The new wave trough has almost reached the BM and the balloon is about to reach its full elongation for this wave system. The revived spring force has rotated the BM almost back to the situation of Picture 1.

Picture 6: The BM travels upwards once more and the momentum created by the revived spring force has caused the BM to continue rotating (in pitch) and now bends in the opposing direction. The CoB has shifted to the right, creating a clockwise momentum. The situation of Picture 3 is about to be repeated.

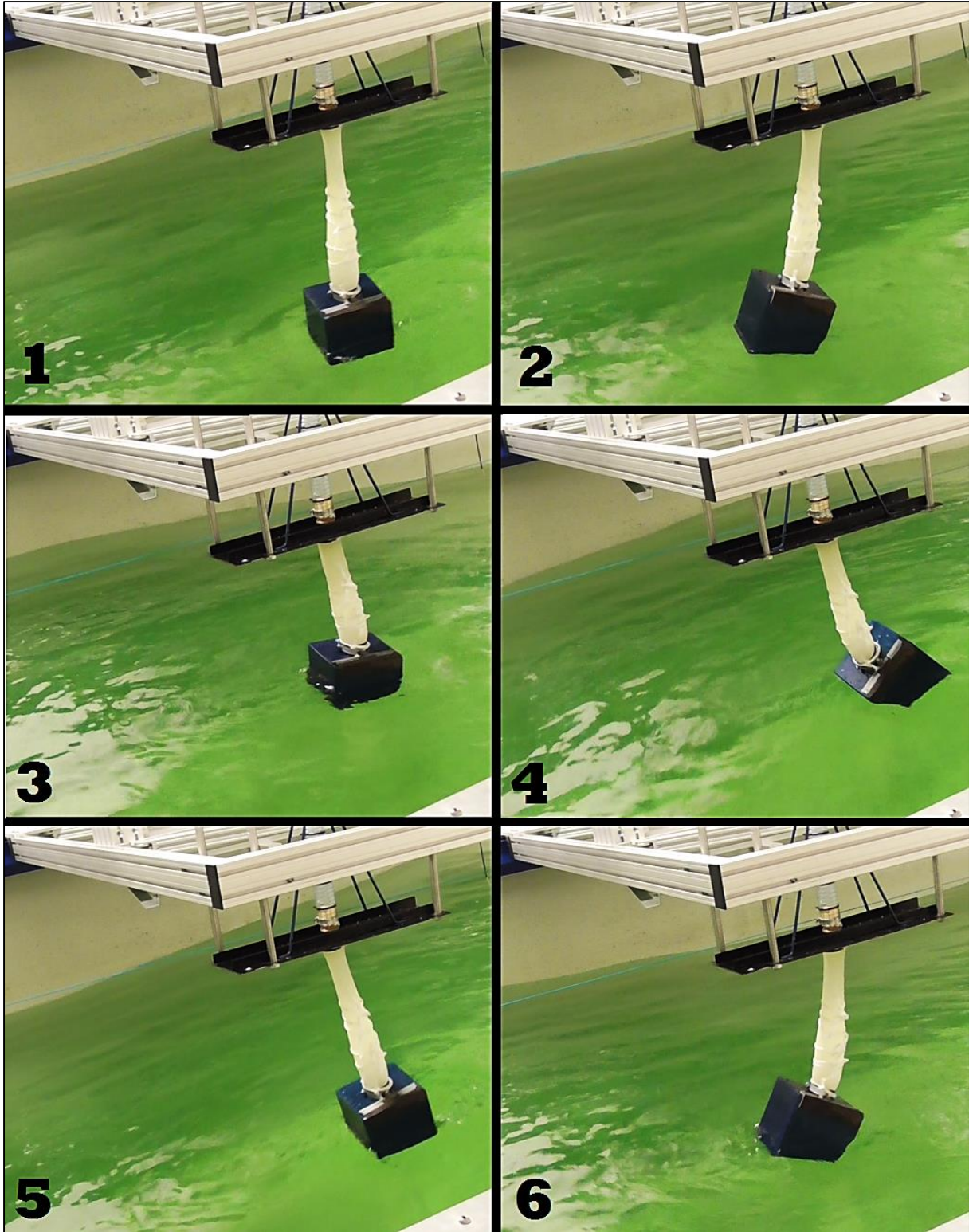

Figure 54. Picture sequence of the pump operating in wave system; $H=200[mm]$, $T=2[s]$

Discussions

In this scenario, the BM experienced significant pitch motion. The pitch motion was generated by the combination of horizontal wave forces and alteration of the CoB, which during the cycle created both clockwise- and counter clockwise momentum. Yet this also occurs with smaller

waves. The arguably most likely reason the BM experienced such pitch in this scenario is that, at some point during the cycle, there is no spring force to restrict the pitch motion.

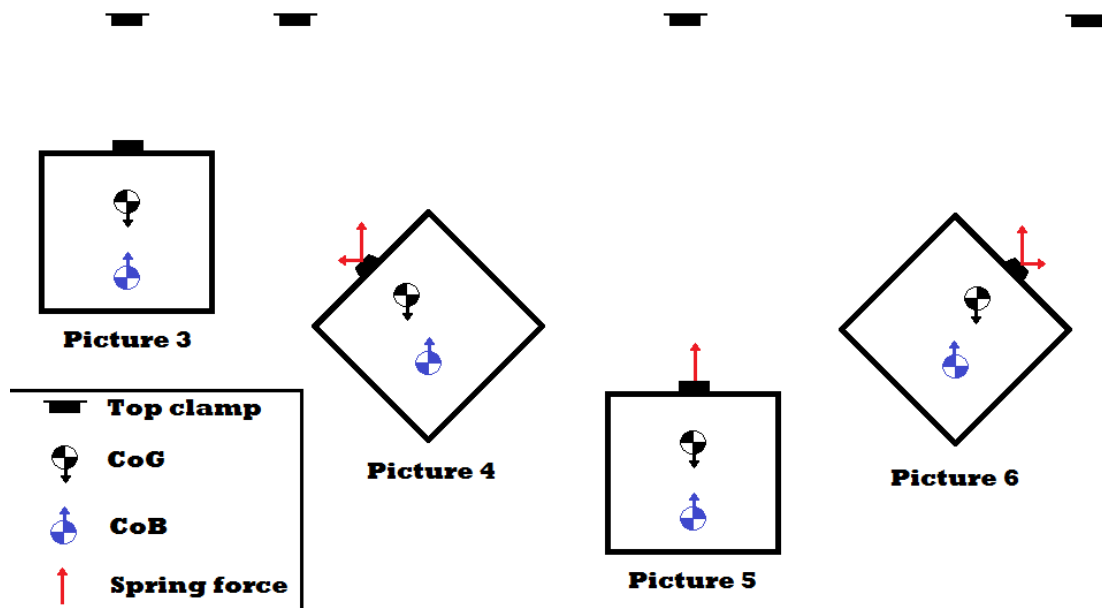

Figure 55. Illustration of BM orientation through a wave cycle in high waves⁸

When the BM floated in the wave crest and the balloon was fully retracted, there was no available spring force to restrict and correct the pitch motion, leading to excessive bending in the balloon directly above the bottom clamp. See the illustration of Figure 55 above.

The BM alone in this prototype is top heavy and initially unstable, but kept upright by balloon and its spring forces. The illustration of Figure 55 shows that momentum and pitch motion would be reduced by lowering the CoG so that the BM is initially stable through gravity-based stability.

Conclusions

The results of the test showed that the BM experienced excessive pitch motion and bending in the balloon while operating in waves that causes the balloon to retract fully. It is open to discussion whether this can be referred to as buckling, but the results validate the expectations. However, it was not foreseen that the BM would experience excessive pitch in the clockwise direction as well.

It may be concluded that the AWACE Production pump should not operate in waves that would cause the balloon to fully retract, but always have some magnitude of elongation.

The tests also revealed that having the BM gravitationally stable reduces pitch and roll motions and must be taken into consideration in future design work.

7.3.6 Test VI – Determining pump operating principle 1

Description

⁸ High waves refers here to waves of a height that would cause the balloon to fully retract.

Development of a Wave-Driven Pump for Energy Production

The first operating principle for the pump is based on the idea that the BM will follow the wave surface in heave with synchronised motion when the BM floats lightly in the water. The purpose of this test was to determine the validity of this principle.

The pump was observed and filmed while operating in various wave systems, varying in both wave- height and period. The test was conducted with the same setup as in Test III, with the 1 ¼” measuring tube.

Expectation

The buoyancy module was expected to have its heave motion synchronised with the waves’ heave motion.

Results

The results were filmed with a video camera. Figure 56 and 57 show four pictures each, taken from the video. Naturally, with static pictures, it is difficult to show that the BM follows the wave motion in a synchronised fashion. This can, in general, only be done by demonstration or video. Nevertheless, some tendencies can be observed by comparing Figure 56 and Figure 57. The pictures are numbered in the bottom left corner in both sequences.

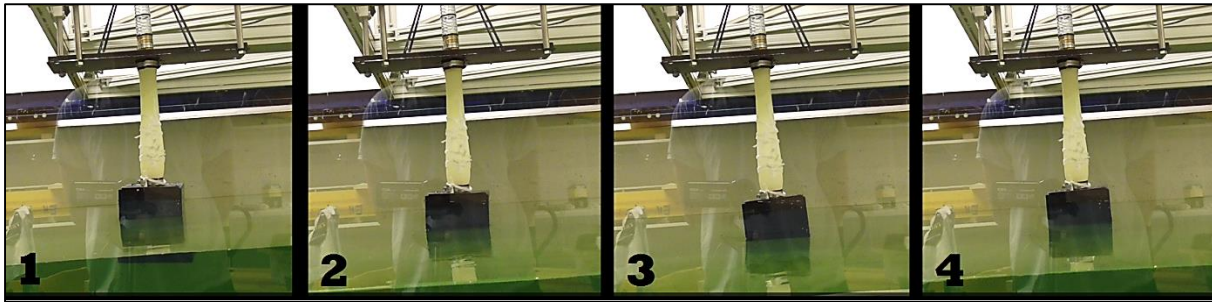

Figure 56. Picture sequence of pump in wave system; $H=40[mm]$, $T=3[s]$

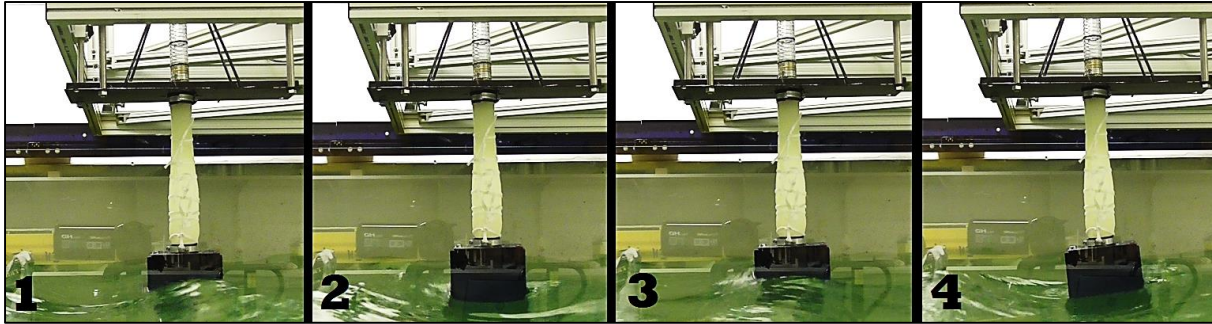

Figure 57. Picture sequence of pump in wave system; $H=40[mm]$, $T=0.58[s]$

The pump was observed operating in a wave system that had a three-second period with 40, 60 and 80 millimetre wave height. The tests showed that the BM had synchronous heave motion with the waves in all three cases, but a tendency for slight delay was observed with increasing wave height.

The BM showed significantly reduced heave motion when the period was reduced to 0.58 seconds. The tests showed that there was not enough time for the BM to go down into the wave trough before the wave was on the rise once more.

Discussions

Synchronised motion is primarily wave period dependant. The BM needs time enough to enter the trough before wave surface rises again. Yet, with increasing wave height, there was observed slight delay in the synchronised motion. Meaning the BM reached its heave motion peak after the wave crest had passed it with increasing distance, see the illustration of Figure 58.

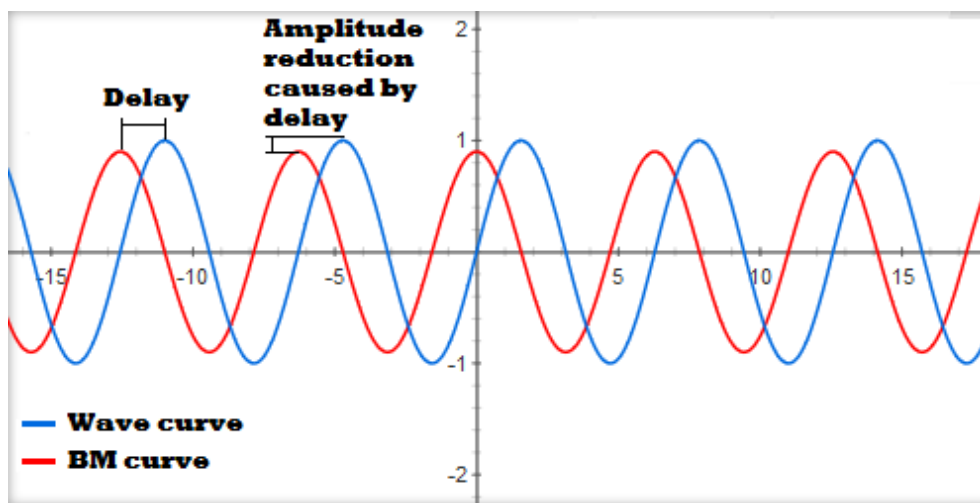

Figure 58. Illustration of the BM's heave motion in the wave zone

Delay limits the utilization of the wave height, which reduces the heave motion amplitude of the buoyancy module. The increased surge motion that the BM experiences in larger waves may be the cause of the delay. It may also be caused by the increased water displacement in higher waves. The moving water column may act as an opposing pendulum, causing the heave motion delay in the BM.

Conclusions

Synchronised motion is seemingly easy to achieve, but delay increases visibly with increased wave height. Delay may be reduced by reducing surge in the BM. However, the primary requirement for obtaining synchronised motion is to have the pump operating in a wave system with sufficiently large periods. A numerical description of the period requirement for synchronised motion was not attained.

7.3.7 Test VII – Determining pump operating principle 2

Description

The second operating principle for the pump is based on the idea that the BM will follow the wave surface in heave with resonant motion. Resonance occurs if the wave period is in and about the Eigen-period of the pump. The purpose of this test was to determine the validity of this principle and the validity of the Eigen-period model in section 7.1.3.

Development of a Wave-Driven Pump for Energy Production

The pump was filmed while operating in wave systems that varied in frequency in the attempt to converge to the correct wave period that caused resonant motion. The test was conducted with the same setup as in Test III, with the 1 ¼” measuring tube.

Expectation

The pump was expected to have resonant motion when the wave period was between 0.5 seconds and 0.65 seconds.

Results

The first attempt to reach resonance was with the wave system of Figure 57. In this wave system, the BM had very little heave motion and did not follow the wave surface.

The second attempt was with the wave system given in Figure 59, the red lines marks the location of the waterline. In this scenario, the BM did follow the wave motion in heave, but with significant delay. Yet the amplitude of the motion was significantly larger than in waves of same height, but longer period. The measured head in this system was 120 millimetres, which was surprising considering that the waves of 160-170 millimetres resulted in 175 millimetres of head, with the same tube size.

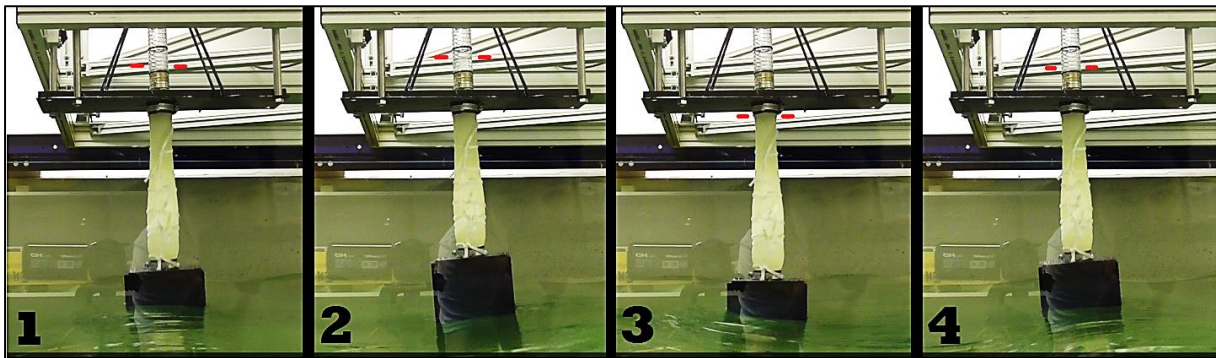

Figure 59. Picture sequence of pump in wave system; $H=40[\text{mm}]$, $T=0.71[\text{s}]$

The third wave system put to the test was with a wave height of 40 millimetres and a period of 0.833 seconds. In this wave system, the BM had what can be described as perfect synchronised motion with no visible delay. Yet the amplitude of the motion was significantly smaller than in the preceding system.

Discussions

Based on the results of the third wave system, the second wave system that was tested showed resonant behaviour. The amplitude of the heave motion and head produced was larger than in other wave systems with the same wave height, but larger period. After careful examination of the video from the test in this wave system, an attempt was made to recreate the module's motion in the wave surface. The motion is graphically displayed in Figure 60.

The graph shows that the peak of the BM's heave motion occurs just after the SWL passed it. In other words, there is much delay between the peak of the BM's heave motion and the crest of the wave. This delay limits the utilization of the wave height, but the pump still had more efficiency in this system, than in a system of longer period, where there was no visible delay.

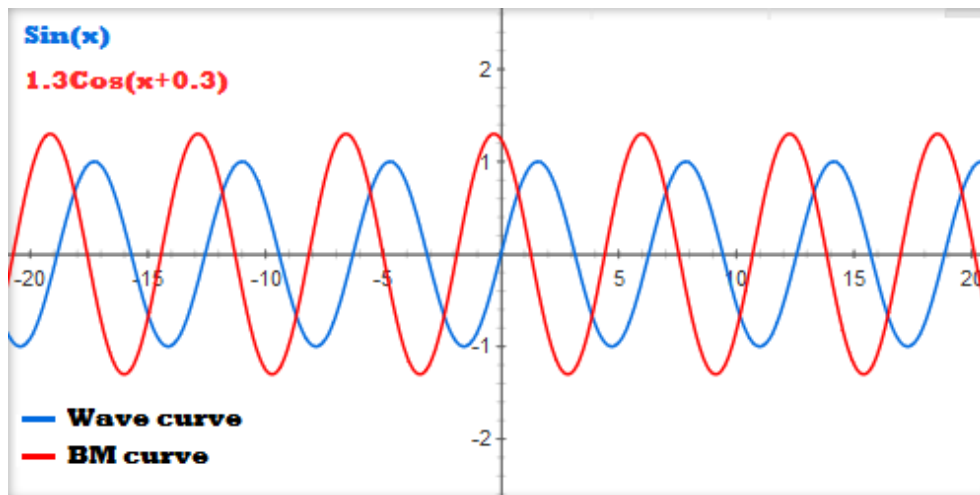

Figure 60. Illustrative recreation of the BM's heave motion curve in resonance

Resonant motion was achieved, but not with the expected period. Resonance was expected to occur with a wave period between 0.5 and 0.65 seconds, yet the results of the tests indicate resonance between 0.7 and 0.75 seconds. There are a number of influencing factors that may cause discrepancies from the model of section 7.1.3, such as:

- With the SWL causing the balloon to elongate 50 per cent and with a wave height of 40 millimetres would suggest that the BM was floating in the waves with the balloon elongated between 37.7 and 62.3 per cent. However, since the wave pool system was not calibrated, it is possible that the distance from SWL to crest was larger than the distance from SWL to trough. This would cause the balloon to operate with a different range of stiffness.
- There may be more water contained within the pump than what was assumed in the model. The additional mass would increase the Eigen-period of the pump.
- The model did not account for hoop strain in the balloon, only longitudinal strain. The additional strain on the balloon reduces the spring stiffness. The reduced stiffness increases the Eigen-period of the pump.
- The motion of the water contained within the pump may create a damping effect when forced into a tube of smaller diameter.
- The motion of the water contained within the pump may act as an opposing pendulum, affecting the Eigen-period of the pump.
- The wave pool system was not calibrated, so the input wave period may not be accurate.
- The hydrodynamic added mass may differ from the assumed value in the model.

Conclusions

Resonant motion was achieved, and the test results showed that the pump produces more head in resonance. Resonance occurred with a wave period larger than the expectation. A number of influencing factors that may cause discrepancies from the model has been established.

It is important knowledge for future design work to know that resonance in heave has a desired effect, and if managed, a highly valuable phenomenon for the concept.

7.3.8 Test VIII – Determining the impact of sloshing

Description

The buoyancy module experiences six different motions during wave interaction. Roll and pitch motion and acceleration in surge and sway, in particular, will create sloshing if the BM contains liquid with a free surface. Figure 61 illustrates sloshing in the scenario of having the BM partially filled with water during a wave cycle.

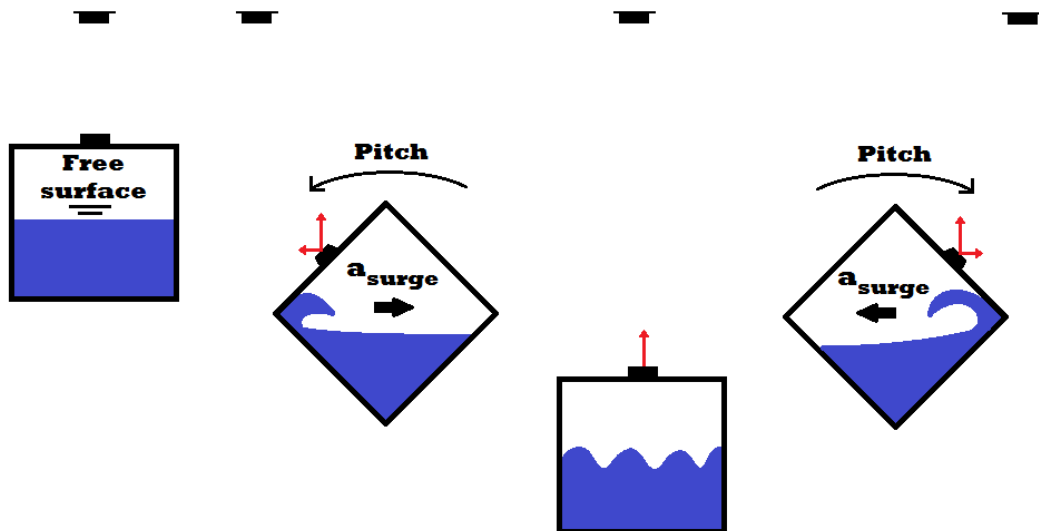

Figure 61. Illustration of sloshing in the BM during a wave cycle

The sloshing effect may enhance the roll and pitch motion, which increases bending induced stress in the balloon. Sloshing can potentially also disturb the cyclic motion of the BM, reducing the pump's productivity. The purpose of this test was to determine the effect which sloshing has on the pump.

Using the 1 ¼" measuring tube, the test was conducted with the same setup as in Test III, but the BM was in addition half-filled with water. The measured wave height of the wave system varied in between 160 and 170 millimetres. The input wave period was set to three seconds.

Expectation

Sloshing effects in the buoyancy module was expected to cause excessive bending in the balloon directly above the bottom clamp.

Results

The first part of the test was operating the BM dry. A picture sequence of the wave cycle is shown in Figure 62.

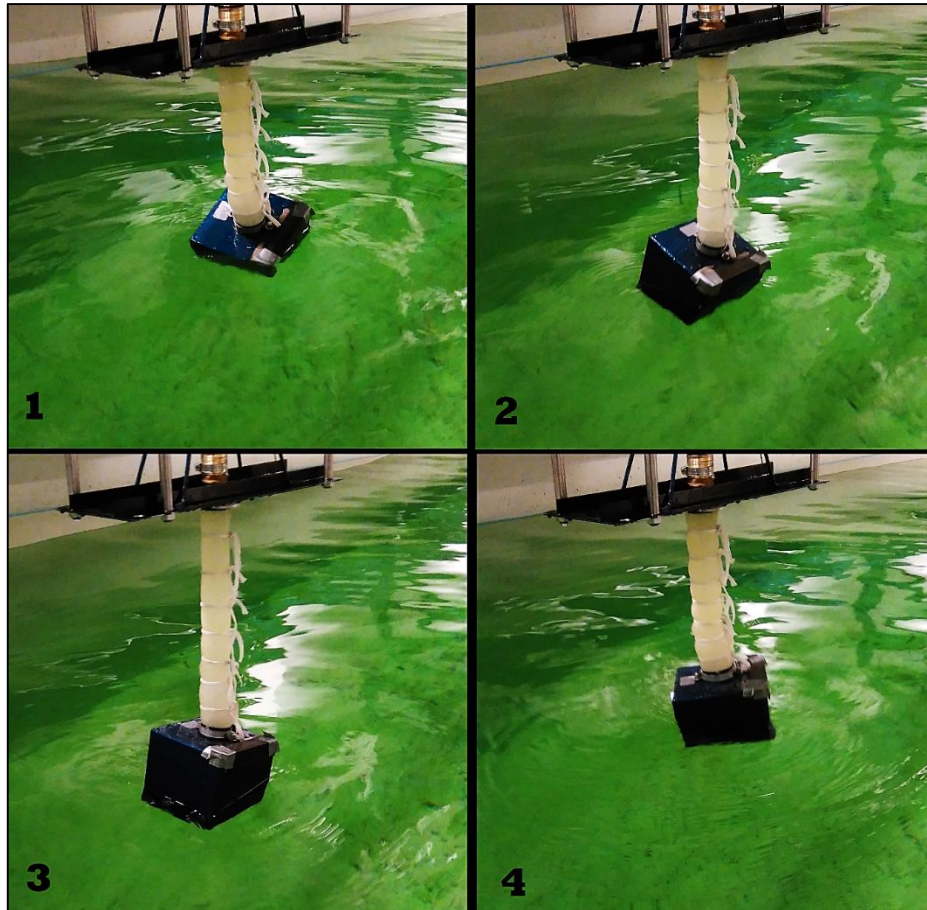

Figure 62. Picture sequence of pump with empty BM in wave system; $H=160[\text{mm}]$, $T=3[\text{s}]$

The second part of the test was operating the BM half-filled with water, but with the same wave system. A picture sequence of a wave cycle with the half-filled BM is shown in Figure 63.

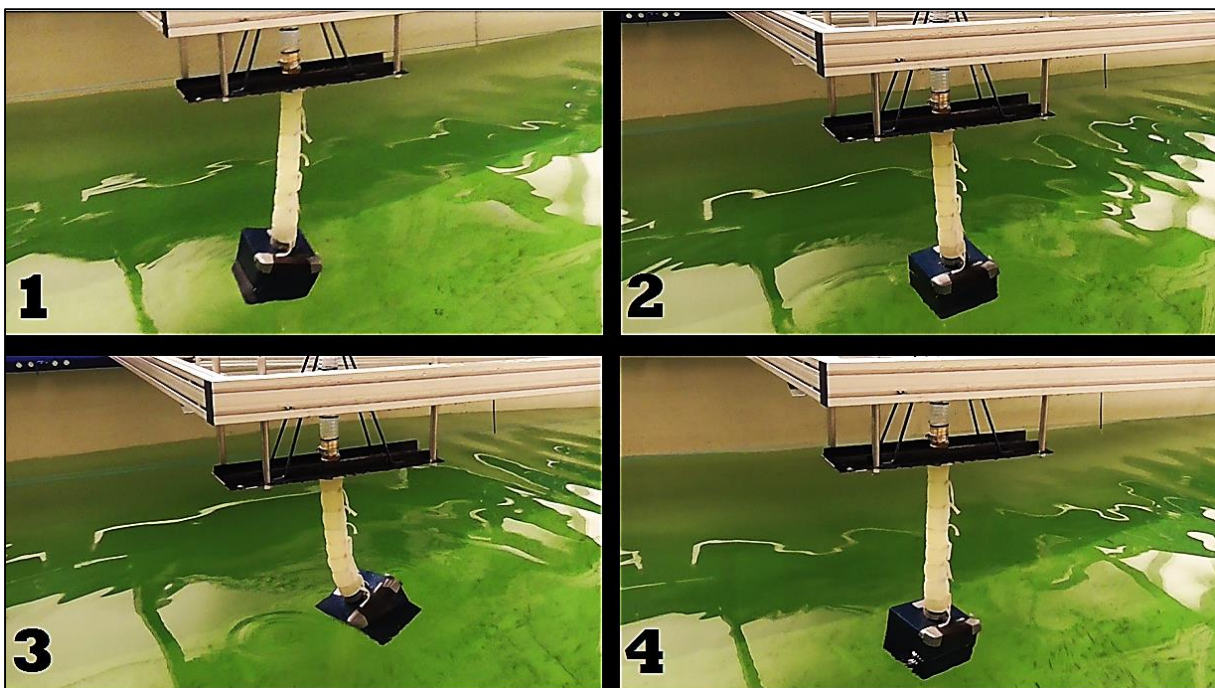

Figure 63. Picture sequence of pump with BM half-filled with water in wave system; $H=160[\text{mm}]$, $T=3[\text{s}]$

Development of a Wave-Driven Pump for Energy Production

Both parts of the test was filmed. A descriptive comparison for the six degrees of freedom could be concluded after close examination of the videos. The comparisons are given in Table 10 and are formed on a visual basis only.

Table 10. Comparison of BM motion between scenario with and without water in BM

	With water in buoyancy module	Without water in buoyancy module
Surge	Less surge motion	More surge motion
Sway	Less sway motion	More sway motion
Heave	No observed difference	No observed difference
Roll	Less roll motion	More roll motion
Pitch	More violent return-pitch ⁹	Steady motion
Yaw	Less than 45° motion	More than 45°, less than 60° motion

Discussions

As expected, the pitch motion was of a more violent nature with water inside the buoyancy module. Yet most other motions were reduced. The most likely explanation for why this was the case is arguably the influence of increased stability.

The water weight lowered the CoG and raised the CoB. The combination of which caused the BM to be gravitationally stable. The increased stability reduced surge, sway, roll and yaw motion. It is likely that the increased stability also reduced pitch motion, but the effect of sloshing was a more influential contributor. There was no observed difference in heave motion or head production.

Conclusions

The results of this test are partially inconclusive. Comparing the motions with and without water in the buoyancy module showed that pitch motion was increased by sloshing. This means that for future design work, the buoyancy module should be compartmentalised if the pump comprises the feature of pumping fluid in and out of the module with the intention of adjusting elongation or the Eigen-frequency.

The other motions (except heave) were reduced by the increased stability of the BM, which hid any conclusions as to how a free water surface in the BM influences these motions. The results of this test therefore also emphasize the importance of having the BM initially stable.

7.3.9 Test IX – Determining the influence of draft distribution

Description

Test III to, and including, Test VIII entail operating the prototype with an angle steel bar attached to the BM. The bar functions as payload, purposely situating the CoG in the geometric centre of the BM in order to attain a uniform draft distribution enclosing the BM, as illustrated in Figure 64.

⁹ Return-pitch refers to the motion that corrects the pitch motion caused by waves and returns the BM towards the still-water situation.

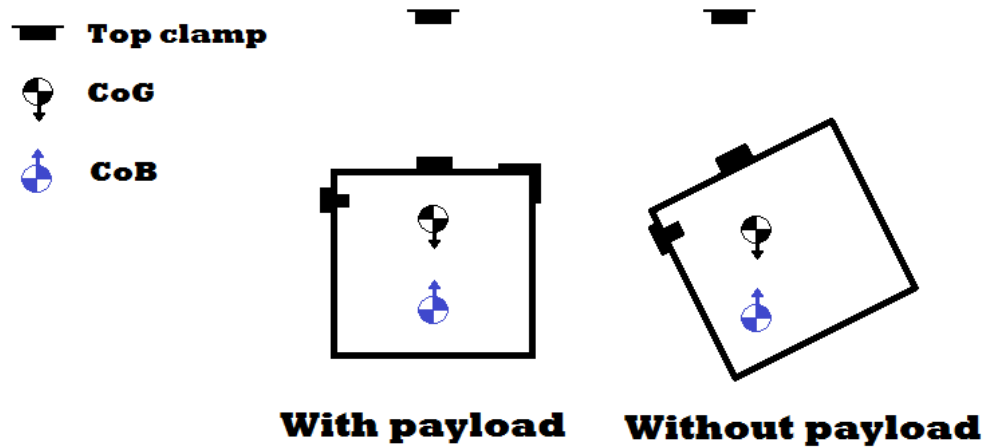

Figure 64. Illustration of the BM floating with and without payload

The orientation of the BM influences the magnitude of stress in the balloon, but also influence the effect of horizontal wave forces on the BM. The purpose this test was to determine how the buoyancy module’s motions are affected by non-uniform draft distribution.

The test was conducted with the 1 ¼” measuring tube and the same setup as in Test III, but now without the attached payload. The wave height was measured between 160 and 170 millimetres and the input value for the wave period was three seconds.

Expectation

Uneven draft on the buoyancy module has a visibly negative impact on the pump’s motion and productivity.

Results

Figure 51 displays a series of three consecutive pictures. Each picture is numbered in its bottom left corner.

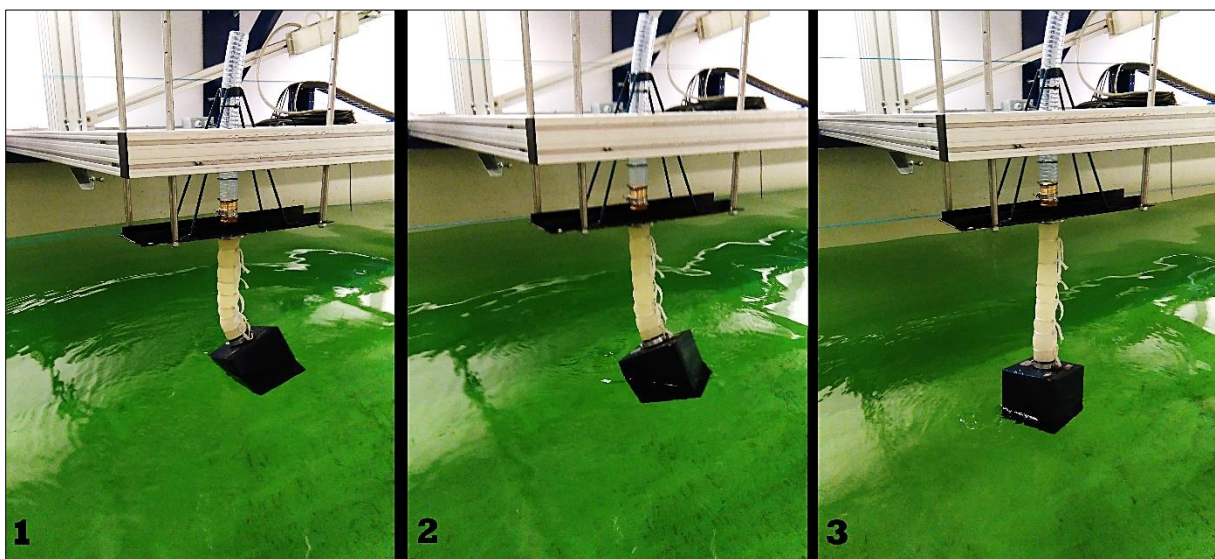

Figure 65. Picture sequence of pump without payload on BM in wave system; $H=160[mm]$, $T=3[s]$

Development of a Wave-Driven Pump for Energy Production

It is challenging to show the motions of the BM in this wave system with static pictures, and the motions should preferably be observed on video.

The test was filmed and the observed motions were compared with the motions observed from the video to Figure 62. A descriptive comparison of the six degrees of freedom could be concluded after close examination of the video. The comparisons are given in Table 11 and are formed on a visual basis only.

Table 11. Comparison of BM motion between scenario with and without payload on BM

	With payload	Without payload
Surge	No observed difference	No observed difference
Sway	Less sway motion	More sway motion
Heave	Max. 175[mm] head produced	Max. 165[mm] head produced
Roll	Less roll motion	More roll motion
Pitch	Less pitch motion	More pitch motion
Yaw	Much less yaw	Much more yaw

Discussions

There was no observed difference in surge motion from the two cases, but there was more motion observed in sway, roll and pitch without the payload attached to the BM. In regards to heave motion, there was no observed difference, but there was observed less head production. The reduced head may have come from reduced heave motion, but it may also be caused by the intensification of the other motions.

The yaw motion was significantly increased without the payload attached and was directed counter clockwise. The increased yaw motion was most likely caused by the geometric change of submerged BM area, see illustration of Figure 66. The wave force in the illustration is directed perpendicularly into the page.

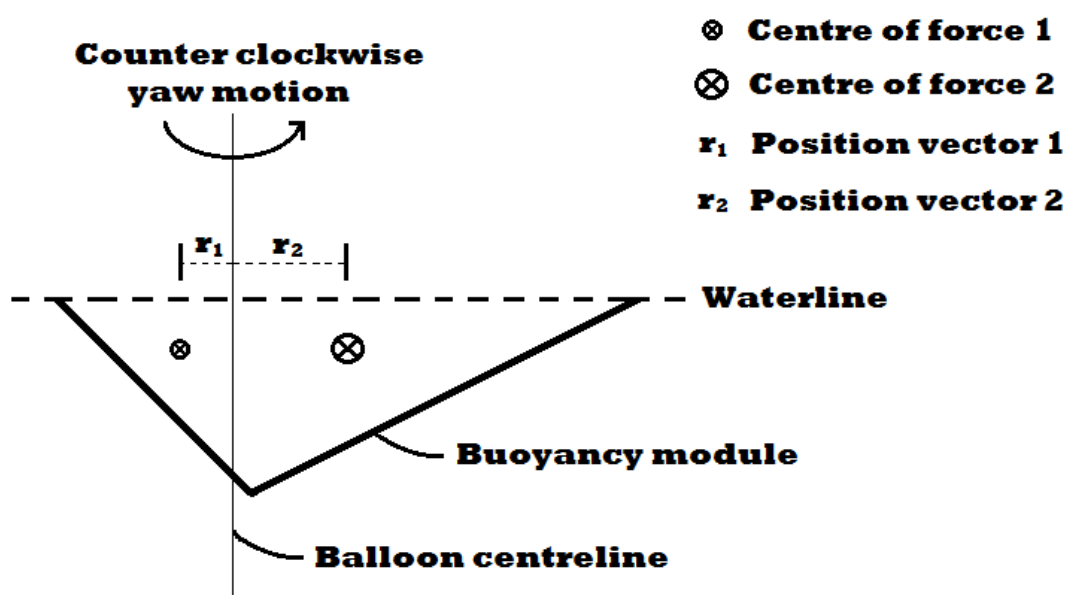

Figure 66. Illustration of wave force impact on submerged BM with uneven draft

The illustration shows the centre of horizontal wave force is larger and has a larger distance on one side of the balloon’s centreline, which creates torque.

Conclusions

The results of the test validate the expectation of increased yaw motion and reduced productivity, but also showed increased sway, roll and pitch motions. The motion of the BM is therefore proven dependent on draft distribution.

For future design work on the concept, the buoyancy module should be designed to have its CoG in its geometric centre in the x- and y-direction (return to Figure 37 for illustration).

7.3.10 Summarised conclusions

Nine tests were conducted with the prototype. Most of which reached a conclusion regarding how to improve productivity, limit undesired motions, or both. Table 12 summarizes the conclusions that are important for future design work, and marks the end of this chapter.

Table 12. Design recommendations for future design work based on test results

Number	Description
1.	The balloon must have sufficient ability to elongate, but the circumferential deformation must be limited as much as possible to achieve optimal efficiency.
2.	Increased heave velocity of the buoyancy module (BM) increases the contained fluid’s energy.
3.	The BM should be designed in a manner that minimizes hydrodynamic resistance.
4.	The balloon should be designed to always be elongated during production.
5.	The pump should be designed so that the balloon can elongate at sufficient rate to improve synchronised heave motion with the waves.
6.	The pump should be designed with an Eigen-frequency likely to cause resonant heave motion.
7.	The BM should be compartmentalised if the pump comprises the feature of pumping fluid in and out of the BM to regulate its weight.
8.	The BM should have its centre of gravity (CoG) below its centre of buoyancy.
9.	The BM should have its CoG in its geometric centre in the x- and y-direction.

In addition to reaching these design-important conclusions was the concept proven in a relevant environment. This alone is a valuable milestone on the road to turn the idea to a marketable product.

CHAPTER 8 – CONCLUDING REMARKS

This is the final chapter of the report and includes an overall discussion of the major aspects of the work performed in the project. The final conclusions are also covered in this chapter, and are followed by a description of a potential future scenario if the concept development continues post thesis.

8.1 DISCUSSIONS

From the beginning to the end of this report, the reader was brought along the course of turning an idea into a concept, into a potentially marketable product and all the way to proving the concept's functionality in a relevant environment.

Three concept suggestions for housing the pump were created based on the conceptual idea, from which a single concept stood out and was concluded as representing the best-fit solution for further development. This may not be the case had the same concept selection procedure been conducted by experienced product-development engineers. More importantly, engineers with experience in developing jacket structures, and similar, from the O&G industry may be able to come up with better solutions for housing the "AWACE Production" pump. The jack-up housing concept comprised three pumps, but improving the housing concept may result in a concept that can include even more pumps. Such an improvement can significantly reduce construction costs per installed pump, increase productivity and overall make the concept a more competitive solution.

If the AWACE Production pump is unable to deliver a sufficient energy output, then it will make little difference how many pumps there are installed on a single platform. An early estimation of the electric energy output was concluded with good results, but the calculation process included many assumptions prone to questioning. The underlying uncertainties therefore, in a sense, impair the estimation. Nevertheless, the estimated potential gave good results, which motivate the student to continue the work on the concept. Furthermore, by comparing the sheer size of the AWACE pump concept to the Pelamis concept, it does not seem far-fetched that an AWACE pump is able to deliver 0.9 megawatts when a Pelamis generator is able to deliver 0.75 megawatts.

The prototype that was built as part of this project was designed in a simple manner, yet the tests conducted showed quite conclusive results. These test results together formed an array of design requirements, which may be used if developing another prototype. The second prototype should then be designed as a scaled model of what would be considered the first full-scale product. Testing with such a prototype may uncover much information required to give a thorough estimation of the output potential of the full-scale product.

The tests also showed that balloon bulging is a destructive attribute with regard to productivity. The circumferential change caused by hydrostatic pressure revealed that the rubber balloon cannot alone function sufficiently, but must be constrained in a manner that allows the balloon to elongate. Therefore, future design work should place much attention to developing a balloon with good ability to elongate, but has limited ability to change circumferentially. This may be achieved by using a spring enveloped in a rubber or rubber-like material, or by developing a balloon in a stiffer material that is moulded in a shape allowing sufficient elongation.

8.2 CONCLUSIONS

This thesis regards the development of a new concept for harvesting the energy potential of ocean waves. The concept involves a new pumping mechanism comprising an elongating member, known as a balloon, which contains a liquid. The balloon hangs from an offshore platform in one end and floats on the ocean surface in the other. Buoyancy and vertically directed wave forces retracts the elongated balloon, causing it to displace the liquid contained within. This pumping method is thought to be able to transport seawater to a nearby onshore desalination plant for production of clean water, typically as a source for drinking water or irrigation. This document, however, maintains focus on the pump's ability to produce electric energy from the liquid's motion.

The pumping concept is apparently new, as no previous, current or pending patents were found to cover this technology. Nor does internet search find any products, drawings, etc. that would contradict the concept's novelty. This does not however exclude the possibility that others may have thought of the same, but until proven otherwise, the pumping mechanism is the invention and property of the student. A Norwegian patent draft was prepared, and at the Stavanger courthouse stamped as proof of intellectual property. An English-written international patent draft was also prepared as this concept potentially serves better purpose in the international market than just in Norway.

Concept idea-generation found that using the jack-up platform concept from the oil and gas industry as the best-fit solution to accommodate the pump offshore. This concept has numerous advantageous features, making it well suited to form part of a potentially marketable product. In addition to these features also comes the opportunity of repurposing old jack-ups that are no longer fit to serve their original purpose.

The pumping concept, being part of the student-developed concept dubbed "AWACE Production", was in this thesis considered to operate in two different modes of operation. The first mode of operation was having the elongating part of the pump follow the wave surface in heave in a synchronised fashion. The second mode of operation was ensuring the pump's Eigen-frequency to match the heave frequency of the waves to promote resonant motions.

The first mode of operation formed the basis for establishing an embryonic estimate of the pump's potential energy output. The estimate is subject to high degree of uncertainty, but the results support the decision in favour of continuing the development process. A sample value of the estimate is 0.9 megawatts with a balloon of four metres in diameter working in swell waves of five metres in height and a period of ten seconds.

A prototype of the pump was developed as part of the project. The prototype was tested in the wave pool facility of Bergen University College and the results proved the functionality of the concept in a relevant environment. Other tests were conducted at University of Stavanger and together the tests resulted in an array of design requirements for optimising production and life expectancy of the pump. These design requirements are quite useful in case the student gets the opportunity to continue working on the concept.

In closing, this project was the student's final piece of the educational puzzle spanning the course of 20 years. The student was given a rare opportunity to pursue the development of an

invention as part of the master's education program. The project also required the student to familiarize himself with much knowledge that largely reside outside the curriculum, such as the process of product development and the science of intellectual property and patenting. The development process required implementing knowledge gained from various courses from the past year and a half in order to achieve the goals of the project. The thesis can, in short, be described as educational and exciting.

8.3 FURTHER WORK

The student has decided to continue the development process after thesis completion. This means that there is still a lot to do. One of the major steps ahead is thoroughly designing the full-scale pump with particular focus on turbine selection and optimal fluid flow, not to mention the balloon. A scaled working model can be built once the foundation for the design is established. The model should be uniformly scaled and include all the required parts and functions. Testing with such a prototype should be able to procure the necessary information needed to determine the productivity of the full-scale unit, and thus the financial viability of the concept.

Unfortunately, the design part is the easy part. The hard part is to obtain the necessary means to put the plans into action. As mentioned earlier in the document, transforming an idea to a marketable product is unfeasible for one person to execute. The development project will converge to a point where the student will require the support of a dedicated project team. This will require the student to be able to encourage other companies or institutions to take part in this development project, either in the form of management, engineering support and/or financial support.

Knowing in full the personal strain such a project may demand, the student is aware that knowing when to quit is just as important as having the perseverance to continue.

REFERENCES

- Bower, A. F. (2008). *Constitutive models - Relations between stress and strain*. Retrieved June 2, 2016, from website of Applied mechanics of solids: http://solidmechanics.org/text/Chapter3_5/Chapter3_5.htm
- Carnegie. (2015, October). *CETO 6 garden island project western Australia*. Retrieved March 14, 2016, from website of Carnegie wave energy: http://carnegiwave.com/wp-content/uploads/2015/06/CP115-0020-0_PRS-CETO-6-Community-Information-Sheet_Web.pdf
- DNV. (2010a). Environmental conditions and environmental loads. In *Recommended practice DNV-RP-C205* (p. 33). Det Norske Veritas.
- DNV. (2010b). Environmental conditions and environmental loads. In *Recommended practice DNV-RP-C205* (p. 100). Det Norske Veritas.
- DNV. (2011, April). *Recommended practice DNV-RP-C104 - Self-elevating units*. Retrieved March 20, 2016, from website of DNV GL: <https://rules.dnvgl.com/docs/pdf/DNV/codes/docs/2011-04/rp-c104.pdf>
- Elert, G. (2016, March). *Bouyancy*. Retrieved April 19, 2016, from website of The physics hyper textbook: <http://physics.info/buoyancy/>
- Falcão, A. F. (2009, October 22). *Wave energy utilization: A review of the technologies*. Retrieved March 10, 2016, from website of ScienceDirect: <http://www.sciencedirect.com/science/article/pii/S1364032109002652>
- Fornybar. (2016, February 14). *Bølgekraft*. Retrieved March 10, 2016, from website of Fornybar: <http://www.fornybar.no/nye-teknologier/bolgekraft>
- Gardiner, P. D. (2005). The project manager, sponsor and other stakeholders. In P. D. Gardiner, *Project management* (p. 120). Hampshire: Palgrave Macmillan.
- Gough, M. (2015, February 23). *World's first grid-connected wave power station switched on in Australia*. Retrieved March 14, 2016, from website of Science alert: <http://www.sciencealert.com/world-s-first-grid-connected-wave-power-station-switched-on-in-australia>
- Gudmestad, O. T. (2015). Linear wave theory. In O. T. Gudmestad, *Marine technology and operations - Theory & practice* (p. 23). Southampton: WIT Press.
- Gudmestad, O. T. (2015). Wave loads. In O. T. Gudmestad, *Marine technology and operations - Theory & practice* (p. 83). Southampton: WIT Press.
- Institute of marine research. (2014, July 16). *Sirkulasjon og vannmasser*. Retrieved April 2, 2016, from website of Havforskningsinstituttet: http://www.imr.no/temasider/havomrader_og_okosystem/nordsjoen_og_skagerrak/sirkulasjon_og_vannmasser/nb-no

Development of a Wave-Driven Pump for Energy Production

- Johnson, N., & Olson, E. (2010). *What is an oscillating water column?* Retrieved March 14, 2016, from website of Oscillating water column (OWC): <http://owcwaveenergy.weebly.com/index.html>
- Kartverket. (2016). *Tidevannstabeller*. Retrieved April 21, 2016, from website of Kartverket: <http://www.kartverket.no/en/sehavniva/Tidevann-og-vannstand/Tide-Tables/>
- Kolsofszki, M. (2015, November). *Intellectual property rights*. Retrieved February 12, 2016, from website of Prekubator TTO: <http://prekubatortto.no/>
- Krogstad, H. E., & Arntsen, Ø. A. (2000). Linear wave theory. In H. E. Krogstad, & Ø. A. Arntsen, *Linear wave theory part a* (p. 32). Trondheim: Norwegian University of Science and Technology. Retrieved March 11, 2016, from NTNU: http://folk.ntnu.no/oivarn/hercules_ntnu/LWTcourse/lwt_new_2000_Part_A.pdf
- Lazinski. (2010, May 28). *Global wave resources*. Retrieved April 2, 2016, from website of Energy and the environment - A coastal perspective: <http://coastalenergyandenvironment.web.unc.edu/ocean-energy-generating-technologies/wave-energy/global-wave-resources/>
- MIT. (2014). *Concept selection*. Retrieved April 17, 2016, from website of Massachusetts institute of technology: <http://appinventor.mit.edu/explore/sites/all/files/teachingappcreation/unit4/DesignUnit4.pdf>
- MYCAPE. (2016). *Climate & ocean tides*. Retrieved April 21, 2016, from website of MYCAPE: <http://www.mycap.co.za/climate-ocean-tides/>
- NaturEnergia. (2015, May 22). *Posts*. Retrieved April 24, 2016, from website of Naturenergia: https://plus.googleapis.com/wm/4/+Naturenergia_impanti/posts
- NOAA. (2014, November 24). *Where is the highest tide?* Retrieved April 20, 2016, from website of National oceanic and atmospheric administration: <http://oceanservice.noaa.gov/facts/highesttide.html>
- NORSOK. (2007). Hydrodynamic actions. In *N-003 - Actions and action effects* (p. 13). Standards Norway.
- Norwegian Environment Directorate. (2016, February 22). *Sea level change for Norway: Past and present observations and projections to 2100*. Retrieved April 21, 2016, from website of the Norwegian environment directorate: <http://www.miljodirektoratet.no/no/Publikasjoner/2015/September-2015/Havnivaendring-i-Norge/>
- Norwegian ministry of oil and energy. (2014, December 8). *Fornybar energiproduksjon i Norge*. Retrieved February 15, 2016, from website of Regjeringen: <https://www.regjeringen.no/no/tema/energi/fornybar-energi/fornybar-energiproduksjon-i-norge/id2343462/>

- Næser, H. (2012). Bølgeenergi. In H. Næser, *ENE100 Fornybar energi* (p. 10.3). Grimstad: University of Agder.
- Ocean Power Delivery LTD. (2013, February 16). *The Pelamis wave energy converter*. Retrieved March 3, 2016, from website of Idaho national laboratory: http://hydropower.inl.gov/hydrokinetic_wave/pdfs/day1/09_heavesurge_wave_devices.pdf
- Patentstyret. (2015, July 31). *Hva er et patent?* Retrieved February 12, 2016, from website of Patentstyret: <https://www.patentstyret.no/no/Patent/Hva-er-et-patent/>
- Patentstyret. (2016, February 18). *Profesjonell hjelp i søknadsprosessen*. Retrieved April 19, 2016, from website of Patentstyret: <https://www.patentstyret.no/no/Patent/Hvordan-soke-patent/Hjelp-i-soknadsprosessen/>
- Pauling, L. (n.d.). *Quotations about ideas*. Retrieved April 16, 2016, from website of Quote garden: <http://www.quote garden.com/ideas.html>
- Power-Technology. (2016, March 5). *Pelamis, world's first commercial wave energy project, Agucadoura, Portugal*. Retrieved March 15, 2016, from website of Power-technology: <http://www.power-technology.com/projects/pelamis/>
- Robert Q. Riley Enterprises. (2016). *Product design & development*. Retrieved April 12, 2016, from website of Robert Q. Riley enterprises: <http://www.rqriley.com/pro-dev.htm>
- Rubber Style. (2016, March 16). *Naturgummi*. Retrieved April 9, 2016, from website of Rubber style: http://www.rubberstyle.com/?page_id=3473
- Ryan, V. (2013). *What is technology push ? what is market pull ? revision cards*. Retrieved April 14, 2016, from website of Technologystudent: <http://www.technologystudent.com/prddes1/revcardtec1.html>
- Seabased. (2015, September 18). *Seabased wave energy*. Retrieved March 15, 2016, from website of Seabased: <http://www.seabased.com/en/technology/seabased-wave-energy>
- SSB. (2014, July 14). *Energibruk i husholdningene, 2012*. Retrieved June 14, 2016, from website of Statistics Norway: <https://www.ssb.no/energi-og-industri/statistikker/husenergi/hvert-3-aar/2014-07-14>
- Techet, A. H. (2005). *Design principles for ocean vehicles*. Retrieved March 13, 2016, from website of Massachusetts institute of technology: http://ocw.mit.edu/courses/mechanical-engineering/2-22-design-principles-for-ocean-vehicles-13-42-spring-2005/readings/r8_wavespectra.pdf
- The Coca-Cola Company. (2016). *A short history of the Coca-Cola company*. Retrieved February 11, 2016, from website of The Coca-Cola company: http://www.coca-colacompany.com/content/dam/journey/us/en/private/fileassets/pdf/2011/05/Coca-Cola_125_years_booklet.pdf

Development of a Wave-Driven Pump for Energy Production

- USPTO. (2014, January). *Nonprovisional (utility) patent application filing guide*. Retrieved February 15, 2016, from website of United States patent and trademark office: <http://www.uspto.gov/patents-getting-started/patent-basics/types-patent-applications/nonprovisional-utility-patent#heading-19>
- Validé. (2016, May 18). *Project Plogen application*. Retrieved from website of Validé: <http://www.valide.no/en/>
- Wave Dragon. (2005). *Simple and robust construction - complex design*. Retrieved March 14, 2016, from website of Wave dragon: http://www.wavedragon.net/index.php?option=com_content&task=view&id=6
- Wikipedia. (2015, July 3). *Significant wave height*. Retrieved March 12, 2016, from website of Wikipedia: https://en.wikipedia.org/wiki/Significant_wave_height
- Wikipedia. (2016, April 18). *Buoyancy*. Retrieved April 19, 2016, from website of Wikipedia: <https://en.wikipedia.org/wiki/Buoyancy>
- Williams, A. (2016, February 3). *Sotenäs wave energy plant reaches grid connection milestone*. Retrieved March 15, 2016, from website of Maritime journal: <http://www.maritimejournal.com/news101/marine-renewable-energy/sotenas-wave-energy-plant-reaches-grid-connection-milestone>
- WIPO. (2015, September). *Patenting software*. Retrieved February 12, 2016, from website of World intellectual property organization: http://www.wipo.int/sme/en/documents/software_patents_fulltext.html
- WIPO. (2015, October). *The PCT now has 148 contracting states*. Retrieved February 12, 2016, from website of World intellectual property organization: http://www.wipo.int/pct/en/pct_contracting_states.html
- WIPO. (2016). *What is intellectual property?* Retrieved February 11, 2016, from website of World intellectual property organization: <http://www.wipo.int/about-ip/en/>

LIST OF APPENDICES

APPENDIX A – REVIEW OF LINEAR WAVE THEORY FORMULAS	106
APPENDIX B – TIDE PREDICTION TABLE OF STAVANGER COAST 2016	107
APPENDIX C – SIGNED DRAFT OF NORWEGIAN PATENT APPLICATION OF PUMPING MECHANISM	111
APPENDIX D – DRAFT OF ENGLISH PATENT APPLICATION OF PUMPING MECHANISM	115
APPENDIX E – CALCULATIONS OF ENVIRONMENTAL CONTOUR METHOD	120
APPENDIX F – TECHNICAL DRAWINGS OF THE PROTOTYPE	121
APPENDIX G – VIDEOS OF WAVE POOL TESTS	CD

APPENDIX A – REVIEW OF LINEAR WAVE THEORY FORMULAS

Linear Wave Theory Review			
Wave Property	Shallow Water $d/L < 1/20$	Intermediate Water $1/20 < d/L < 1/2$	Deep Water $d/L > 1/2$
Velocity potential	$\phi = \frac{\xi_0 \cdot g}{\omega} \cdot \cos(\omega t - kx)$	$\phi = \frac{\xi_0 \cdot g}{\omega} \cdot \frac{\cosh k(z+d)}{\cosh(kd)} \cdot \cos(\omega t - kx)$	$\phi = \frac{\xi_0 \cdot g}{\omega} \cdot e^{kz} \cdot \cos(\omega t - kx)$
Dispersion relation	$\omega^2 = g \cdot d \cdot k^2$ $L = \sqrt{g \cdot d} \cdot T^2$	$\omega^2 = g \cdot k \cdot \tanh(kd)$ $L = \frac{g}{2\pi} \cdot T^2 \cdot \tanh(kd)$	$\omega^2 = g \cdot k$ $L = \frac{g}{2\pi} \cdot T^2$
Wave profile	$\xi = \xi_0 \sin(\omega t - kx)$	$\xi = \xi_0 \sin(\omega t - kx)$	$\xi = \xi_0 \sin(\omega t - kx)$
Dynamic pressure	$P_d = \rho \cdot \xi_0 \cdot g \cdot \sin(\omega t - kx)$	$P_d = \rho \cdot \xi_0 \cdot g \cdot \frac{\cosh k(z+d)}{\cosh(kd)} \cdot \sin(\omega t - kx)$	$P_d = \rho \cdot \xi_0 \cdot g \cdot e^{kz} \cdot \sin(\omega t - kx)$
Horizontal particle velocity	$u = \frac{\xi_0 \cdot k \cdot g}{\omega} \cdot \sin(\omega t - kx)$	$u = \frac{\xi_0 \cdot k \cdot g}{\omega} \cdot \frac{\cosh k(z+d)}{\cosh(kd)} \cdot \sin(\omega t - kx)$	$u = \frac{\xi_0 \cdot k \cdot g}{\omega} \cdot e^{kz} \cdot \sin(\omega t - kx)$
Vertical particle velocity	$w = \frac{\xi_0 \cdot k^2 \cdot g}{\omega} \cdot (z+d) \cdot \cos(\omega t - kx)$	$w = \frac{\xi_0 \cdot k \cdot g}{\omega} \cdot \frac{\sinh k(z+d)}{\cosh(kd)} \cdot \cos(\omega t - kx)$	$w = \frac{\xi_0 \cdot k \cdot g}{\omega} \cdot e^{kz} \cdot \cos(\omega t - kx)$
Horizontal particle acceleration	$\dot{u} = \xi_0 \cdot k \cdot g \cdot \cos(\omega t - kx)$	$\dot{u} = \xi_0 \cdot k \cdot g \cdot \frac{\cosh k(z+d)}{\cosh(kd)} \cdot \cos(\omega t - kx)$	$\dot{u} = \xi_0 \cdot k \cdot g \cdot e^{kz} \cdot \cos(\omega t - kx)$
Vertical particle acceleration	$\dot{w} = -\xi_0 \cdot k^2 \cdot g \cdot (z+d) \cdot \sin(\omega t - kx)$	$\dot{w} = -\xi_0 \cdot k \cdot g \cdot \frac{\sinh k(z+d)}{\cosh(kd)} \cdot \sin(\omega t - kx)$	$\dot{w} = -\xi_0 \cdot k \cdot g \cdot e^{kz} \cdot \sin(\omega t - kx)$
Phase velocity c	$c^2 = g \cdot d$	$c^2 = \frac{g}{k} \cdot \tanh(kd)$	$c^2 = \frac{g}{k}$
$\omega = 2\pi/T, k = 2\pi/L$ T = wave period L = wave length ξ_0 = wave amplitude g = acceleration of gravity $c = \omega/k = L/T$ = phase velocity		t = time x = direction of propagation z = vertical co-ordinate, positive upward, origin at still water level d = water depth P_d = dynamic pressure P_0 = atmospheric pressure	
			NOTE : η is the new version of ξ

APPENDIX B – TIDE PREDICTION TABLE OF STAVANGER COAST 2016

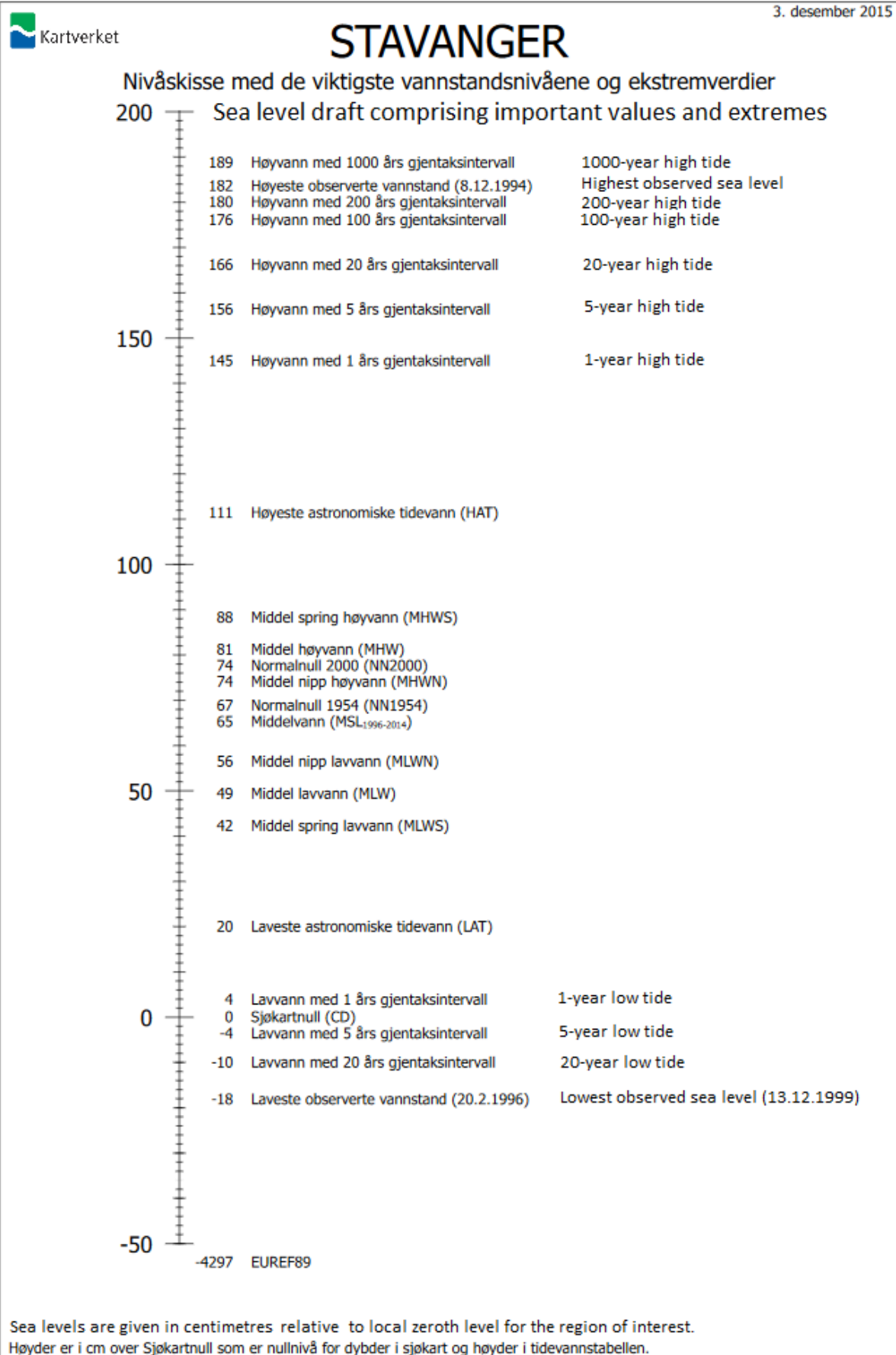



STAVANGER 2016

58°58' N 5°44' E

Tidspunkt og høyder for høy- og lavvann

Januar				Februar				Mars				April			
Tid	cm	Tid	cm	Tid	cm	Tid	cm	Tid	cm	Tid	cm	Tid	cm	Tid	cm
1	0241 87	16	0246 91	1	0318 81	16	0404 80	1	0244 79	16	0337 76	1	0350 71	16	0526 67
Fr	0809 60	Lø	0833 53	Ma	0847 56	Ti	0954 54	Ti	0822 47	On	0928 48	Fr	0937 47	Lø	1224 44
	1456 90		1507 95	☉	1531 81		1633 82		1500 78		1609 75		1621 68		1816 65
	2050 60		2106 51		2120 57		2239 55		2047 49		2200 52		2207 50		
2	0322 84	17	0336 87	2	0401 78	17	0507 77	2	0325 76	17	0438 72	2	0452 69	17	0046 49
Lø	0838 62	Sø	0923 57	Ti	0932 59	On	1127 56	On	0904 51	To	1110 51	Lø	1049 49	Sø	0648 68
☉	1536 87	☉	1600 91		1618 78		1743 78	☉	1545 74		1719 71		1737 66		1323 41
	2126 63		2204 55		2212 59				2133 52		2355 54		2338 51		1930 68
3	0408 81	18	0433 84	3	0459 76	18	0017 56	3	0416 73	18	0554 70	3	0614 69	18	0143 45
Sø	0917 65	Ma	1027 60	On	1031 61	To	0621 76	To	0958 54	Fr	1248 49	Sø	1317 46	Ma	0755 72
	1623 84		1700 88		1728 76		1302 54		1643 71		1842 70		1915 69		1413 37
			2320 58		2326 61		1902 77		2235 55						2024 72
4	0006 64	19	0538 82	4	0623 76	19	0132 54	4	0522 72	19	0113 51	4	0148 47	19	0231 40
Ma	0508 80	Ti	1155 61	To	1351 61	Fr	0739 78	Fr	1113 56	Lø	0718 72	Ma	0743 73	Ti	0844 76
	1010 67		1810 86		1914 76		1407 50		1810 70		1349 45		1416 40		1457 33
	1736 82						2014 80				1957 73		2025 74		2108 76
5	0108 63	20	0042 57	5	0211 57	20	0229 50	5	0135 55	20	0210 47	5	0238 40	20	0313 35
Ti	0636 81	On	0650 83	Fr	0755 79	Lø	0842 83	Lø	0658 72	Sø	0822 77	Ti	0844 79	On	0926 80
	1326 66		1316 58		1437 57		1500 45		1408 52		1440 40		1502 33		1537 30
	1912 82		1922 86		2032 80		2110 84		1957 73		2051 77		2115 81		2146 80
6	0155 60	21	0148 55	6	0252 53	21	0318 46	6	0226 50	21	0257 42	6	0322 34	21	0352 32
On	0749 83	To	0758 86	Lø	0853 84	Sø	0932 88	Sø	0821 77	Ma	0911 81	On	0932 86	To	1004 83
	1415 63		1420 54		1516 51		1546 40		1450 46		1524 35		1545 27		1614 28
	2014 85		2028 88		2120 85		2155 87		2057 79		2134 81		2159 86		2222 82
7	0236 58	22	0244 52	7	0332 48	22	0402 42	7	0308 44	22	0340 37	7	0404 28	22	0428 30
To	0837 87	Fr	0857 90	Sø	0939 89	Ma	1015 92	Ma	0914 84	Ti	0953 86	To	1017 91	Fr	1040 84
	1457 59		1514 49		1554 45	☉	1628 36		1531 39		1604 32		1626 22		1647 27
	2059 88		2123 91		2204 90		2237 90		2142 85		2213 85	☉	2241 90	☉	2257 84
8	0313 54	23	0334 48	8	0411 43	23	0442 38	8	0349 38	23	0419 34	8	0446 24	23	0500 29
Fr	0919 91	Lø	0947 94	Ma	1022 94	Ti	1055 94	Ti	0959 90	On	1031 88	Fr	1101 94	Lø	1114 84
	1535 54		1602 45	☉	1633 40		1707 34		1611 32	☉	1641 30		1707 20		1718 27
	2141 91		2211 94	☉	2246 94		2315 91		2224 90	☉	2250 87		2324 91		2330 84
9	0350 51	24	0419 46	9	0450 39	24	0519 37	9	0429 33	24	0454 32	9	0527 22	24	0530 29
Lø	1000 96	Sø	1033 97	Ti	1104 99	On	1133 95	On	1042 95	To	1107 89	Lø	1144 95	Sø	1147 83
	1612 50	☉	1646 41		1712 35		1743 34	☉	1651 27		1716 29		1748 21		1747 28
	2222 95		2256 96		2328 97		2352 97	☉	2306 94		2325 87				
10	0428 48	25	0501 44	10	0529 36	25	0553 37	10	0509 29	25	0527 31	10	0007 90	25	0004 83
Sø	1041 99	Ma	1116 99	On	1146 101	To	1209 94	To	1124 98	Fr	1141 89	Sø	0607 23	Ma	0600 29
☉	1650 46		1728 40		1752 33		1815 36		1731 25		1747 30		1228 92		1222 81
	2303 98		2337 96						2348 95		2358 87		1828 25		1816 30
11	0506 45	26	0540 43	11	0010 98	26	0027 90	11	0548 28	26	0556 32	11	0050 87	26	0040 81
Ma	1122 102	Ti	1156 99	To	0609 36	Fr	0623 38	Fr	1207 99	Lø	1215 87	Ma	0648 27	Ti	0631 31
	1729 43		1806 41		1229 102		1243 92		1811 25		1814 32		1313 87		1258 78
	2346 99				1832 33		1844 38						1909 30		1848 32
12	0546 44	27	0017 94	12	0053 96	27	0101 87	12	0030 94	27	0031 85	12	0135 83	27	0117 79
Ti	1205 103	On	0616 44	Fr	0649 37	Lø	0650 40	Lø	0628 29	Sø	0624 33	Ti	0730 32	On	0706 33
	1809 42		1235 98		1312 100		1316 89		1250 97		1247 85		1400 81		1337 75
			1842 43		1913 35		1911 41		1851 28		1841 34		1949 36		1923 35
13	0029 99	28	0055 92	13	0136 93	28	0134 85	13	0113 90	28	0105 83	13	0222 78	28	0158 76
On	0626 44	To	0648 46	Lø	0729 40	Sø	0717 42	Sø	0708 32	Ma	0652 35	On	0815 37	To	0745 36
	1248 103		1311 95		1356 97		1349 85		1334 93		1321 81		1450 75		1421 72
	1850 42		1914 46		1955 40		1938 43		1931 33		1910 36		2032 43		2003 39
14	0113 97	29	0131 89	14	0222 89	29	0207 82	14	0158 86	29	0140 80	14	0313 73	29	0242 73
To	0706 46	Fr	0716 48	Sø	0811 44	Ma	0747 44	Ma	0749 37	Ti	0724 37	To	0910 43	Fr	0829 39
	1332 101		1346 92		1443 92		1422 82		1420 87		1357 78		1547 70		1510 69
	1932 44		1943 49		2039 45		2009 46		2013 40		1943 39	☉	2126 48		2050 43
15	0158 95	30	0206 86	15	0310 84			15	0245 81	30	0217 77	15	0413 69	30	0333 71
Fr	0748 49	Lø	0743 51	Ma	0857 49			Ti	0834 42	On	0801 40	Fr	1055 46	Lø	0924 42
	1418 99		1420 88	☉	1534 87			☉	1511 81		1437 74		1655 66		1607 67
	2017 47		2010 52		2130 50			☉	2058 46		2021 43		2326 51	☉	2149 46
		31	0241 83							31	0300 74				
		Sø	0812 53								0843 44				
			1454 85								1524 70				
			2041 54								☉ 2107 47				

Månefasene er vist med følgende symboler: fullmåne ○, nymåne ●, voksende halvmåne ☉, og avtagende halvmåne ☾. Tidspunktene er gitt i norsk normaltid (UTC + 1 time). Sommertid fra siste søndag i mars til siste søndag i oktober. Da må tidene økes med 1 time. Høyder er gitt i cm over sjøkartnull.

APPENDIX C – SIGNED DRAFT OF NORWEGIAN PATENT APPLICATION OF PUMPING MECHANISM



Bølgedrevet pumpe

1

Oppfinnelsens anvendelsesområde

5 Den foreliggende oppfinnelsen vedrører en pumpe ved vannoverflaten, drevet av vannbølger, som forflytter væske, som for eksempel til å drive hydrauliske turbiner, eller transportere sjøvann til en avsaltingsplantasje.

Bakgrunn for oppfinnelsen

10 Drevet av pressende behov for elektrisk, fornybar, energi er metoder for omgjøring av havbølgeenergi til forbrukervennlig strøm et økende teknologisk fagfelt. Flere bølgeenergikonsepter, baserer seg på hivbevegelsen som kommer av oppdriftskraften ved den varierende vannhøyden i bølgesonen. Denne bevegelsen danner også grunnlaget for pumpemekanismen i den foreliggende oppfinnelsen.

15 I tillegg til behovet for produksjon av elektrisk strøm er det et økende behov for rent vann, som for eksempel til jordbruk eller som drikkevann. Et kjent konsept for produksjon av rent vann er å avsalte sjøvann, blant annet gjennom fordampning. En avsaltingsplantasje på land vil kunne ha behov for en drivende mekanisme for sjøvannstilførsel.

20 Når energi bytter faser, går en mengde energi tapt i prosessen. For å utvikle et tilstrekkelig effektivt strømproduserende, eller sjøvannstransporterende system kan det være gunstig å ha få energifaser. Ved å la bølgebevegelsen fra vannbølger være driveren for pumpemekanismen, kan energien fra bølgende potensielt bli effektivt utnyttet.

Tidligere kjent teknikk

25 Det er kjent teknikk å bruke vannbølger til å utøve en hivbevegelse på et stempel for å produsere en mekanisk bevegelse. Det vises til den tidligere kjente patentpublikasjonen med søknadsnummer 20092775, og klasse F03B13/18 (200601), som ansees å være den nærmest liggende kjente teknikken til den foreliggende oppfinnelsen. Den nevnte publikasjonen beskriver og viser en bølgedrevet dobbeltvirkende vertikalt selvjusterende pumpe som inkluderer en neddykket søyleplattform.



Sammendrag av oppfinnelsen

Den foreliggende oppfinnelsen tilveiebringer en metode for å forflytte væske ved bruk av energien til vannbølger, hvor hovedhensiktene er: a) utnytte væskebevegelsen til å drive turbin; og/eller, b) transportere væske til ønsket destinasjon.

Den foreliggende oppfinnelsen beskriver et organ som strekker seg ved økende væskeinnhold i organet. Påføring av vertikal energi fra vannbølger, som for eksempel oppdrift, på det gitte organet, vil bidra til å returnere organet til sin opprinnelige form før væskeinntak, derav forflytte en mengde av væsken i organet.

I form av et lukket system kan organet få tilbakeført den forflyttede væsken når energipåføringen fra vannbølgene avtar. I form av et åpent system kan den forflyttede væsken bli transportert til en ønsket destinasjon, og når energipåføringen fra vannbølgene avtar vil organet strekkes ut og danne et lavtrykk innad organet, som kan føre til pumping av mer væske inn til organet, gjennom for eksempel et rørsystem eller slangesystem fra en eksternt kilde, for eksempel havet.

Figur beskrivelse

Det er vedlagt en figur, Figur 1, som illustrerer en utførelsesform av pumpesystemet ifølge oppfinnelsen. Figur 1 er hensiktsmessig vedlagt som bidrag til forståelse av den foreliggende oppfinnelsen. Pumpen i Figur 1 er anordnet vertikalt stående.

Pumpesystemet (100), illustrert i Figur 1, kan innbefatte et lastbærende element (1), et pumpeorgan (4), et inn-/utløpselement (5), og et innfestningsorgan (2) som kobler det lastbærende elementet (1) og pumpeorganet (4).

Pumpeorganet (4) strekker seg ut med økt innhold av fluid. Når vannbølger (10) påvirker pumpeorganet (4) vil vertikale krefter bidra til å redusere utstrekningen, som vil føre til at mengder av fluiden i pumpeorganet (4) blir forflyttet gjennom inn-/utløpselementet (5). Når de vertikale kreftene fra vannbølgene avtar, vil fluiden returnere til pumpeorganet (4).



Videre kan pumpesystemet (100) også omfatte en oppdriftsmodul (7), som kan være koblet til pumpeorganet (4) med et innfestningsorgan (3). Oppdriftsmodulen (7) kan være utstyrt med et innløpselement (8) og et utløpselement (9).

Oppdriftsmodulen (7) kan tilføre mer oppdriftskraft til pumpeorganet (4).
Oppdriftsmodulen (7) kan være hul og ha et innløpselement (8) for tilførsel av fluid og et utløpselement (9) for uttak av fluid, til å regulere vekten av oppdriftsmodulen (7).

Pumpesystemet (100) kan også være utstyrt med et innløpselement (6). Innløpselementet (6) kan være ført til en ekstern fluid kilde, som for eksempel havet. Når pumpeorganet (4) da strekker seg kan pumpesystemet (100) pumpe inn fluid til pumpeorganet (4) gjennom innløpselementet (6). Deretter, når pumpeorganet (4) trekkes inn vil fluiden forflyttes videre gjennom inn-/utløpselementet (5).

Patentkrav

1. Pumpe, **karakterisert ved** at et elongert pumpeorgan (4) inneholder en fluid, hvor fluiden blir forflyttet av at krefter fra vannbølger reduserer den elongerte lengden av pumpeorganet (4).

2. Pumpe ifølge krav 1, hvor pumpeorganet (4) har en elongert lengde mer enn 5% av ubelastet lengde, foretrukket mer enn 10% av ubelastet lengde, mer foretrukket mer enn 50% av ubelastet lengde, mer foretrukket mer enn 100% av ubelastet lengde, med tilsatt fluid.

3. Pumpe ifølge krav 1 eller 2, hvor pumpen omfatter en oppdriftsmodul (7).

4. Pumpe ifølge krav 1-3, hvor oppdriftsmodulen (7) omfatter et fluidinntakselement (8) og et fluiduttakselement (9).

5. Pumpe ifølge krav 1 eller 2, hvor pumpen omfatter innløpselement (6) for tilføring av fluid til pumpeorganet (4) fra ekstern kilde.





Figur 1

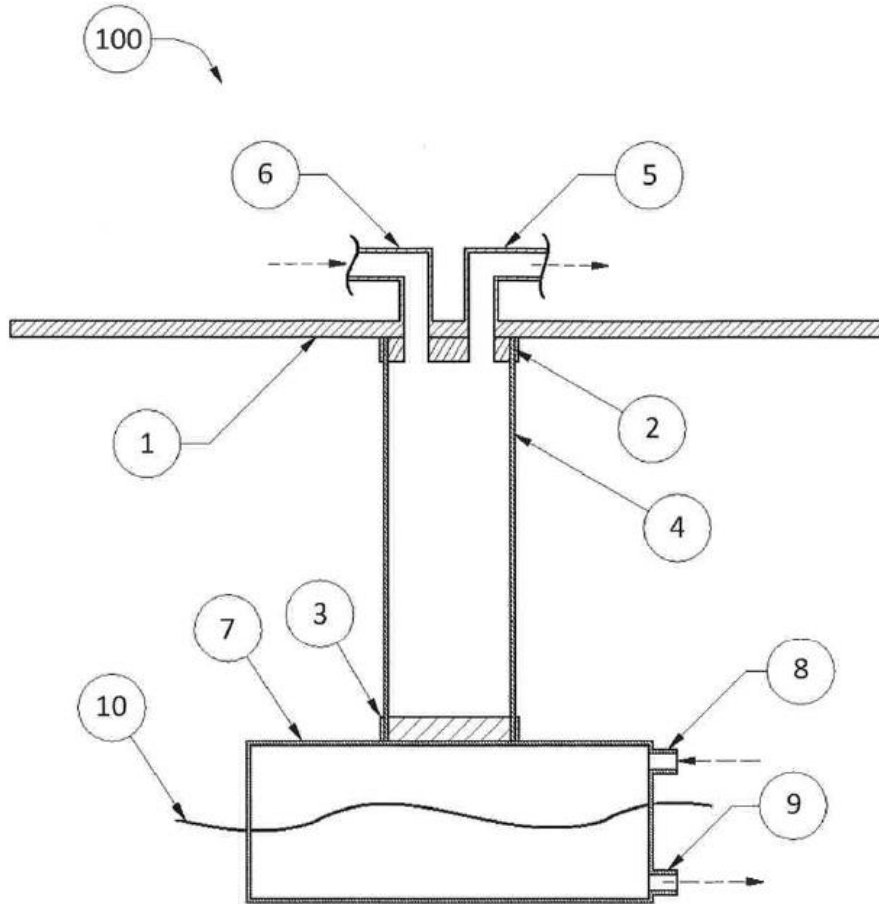

STAVANGER TINGRETT
STAVANGER DISTRICT COURT
BERGELANDSGATE 10
4012 STAVANGER
NORWAY

Presented as an original document
Stavanger tingrett, 18 April 2016

Elisabeth Nygaard
Notary Public
Elisabeth Nygaard
Førstekonsulent

LAE



APPENDIX D – DRAFT OF ENGLISH PATENT APPLICATION OF PUMPING MECHANISM

-1-

Wave driven pump**Abstract**

5 A wave-powered pumping device located in and above the water-wave surface area. The pumping device includes a partially submerged pumping mechanism hanging from an above support structure. The pumping mechanism contains a fluid that is displaced as the elongated length of the pumping mechanism changes due to varying vertical wave inflicted forces.

10 Technical field

This invention relates to pumps, and more specifically to offshore constructions for wave driven renewable energy, but is not limited to that application.

Background

15 Driven by the pressing need for renewable electric energy, methods for converting the energy from ocean waves to user friendly electricity is a technological field on the incline. There are a number of wave-energy conversion concepts that are based on the heave motion caused by the combination of buoyancy force and varying water surface height in the wave zone. This is also one of the major driving forces for this invention.

20 In addition to the increasing need for electrical energy there is an increasing need for clean water. A familiar concept for producing clean water is desalination of seawater, where one method is through evaporation. An onshore desalination plant may need a driving mechanism for intake of seawater, typically a pump.

25 When energy changes phase a certain amount of energy is lost in the process. In order to develop an effective electrical energy production system or seawater transportation system, it may be favourable to have few energy phases. By using the immediate wave motion from ocean waves as the driving force for the pump, the wave energy may potentially be effectively exploited.

Previously known technique

It is a familiar technique to use the combination of buoyancy force and varying sea surface height in the wave zone to exert a heave motion on a piston. This technique transforms hydrodynamic motion into mechanical force.

5

Summary of the invention

The invention provides a method for displacing fluid by exploiting the buoyancy force from a varying local sea surface height and the vertical forces of wave impact. The pump as a system comprises two primary functions.

10 The first primary function is a closed system where the varying elongated length of the pumping member causes the fluid within to move out of the pumping member while under the effect of the impacting wave, only to have the fluid to return to the pumping member when the wave impact dissipates.

15 The second primary function is an open system where the pump may be used to transport fluid from a fluid source, like the ocean. When the wave forces reduce the elongated length of the pumping mechanism, the contained fluid is displaced and transported to a desired location.

20 As the wave forces on the pumping mechanism dissipates, the pumping mechanism elongates and causes an internal low-pressure system, relative to the pressure at the fluid source, hereby allowing the ability to pump fluid from an external source to the pumping mechanism via an inlet.

Brief description of drawing

25 Figure 1 is a cross-sectional view of the pump system with a buoyancy module, an inlet and an outlet for either one-directional flow or two-directional flow.

-3-

Description of embodiment

The attached drawing, Figure 1, is a cross-sectional illustration of a proposed solution according to the invention. The drawing is attached with the intention of aiding in the understanding of said invention. The pump in Figure 1 is arranged vertically.

- 5 The pump (100), illustrated in Figure 1, may comprise a pump member (4), a load-bearing element (1), from which the pump member (4) is suspended, and a conduit (5) for dual directional flow for the fluid contained within the pump member (4). The pump member (4) may be connected to the load-bearing element (1) by means of a clamp mechanism (2).
- 10 The elongated length of the pump member (4) increases with increased amount of fluid contained within. Inflicted by vertical upward-directed forces from waves (10), the elongated length of the pump member (4) decreases and thereby displacing the contained fluid through the conduit (5). The fluid in the conduit (5) flows back into the pump member (4) when the wave impact subsides.
- 15 The pump (100) can further comprise a buoyancy module (7), connected to the pump member (4). The buoyancy module (7) may be connected to the pump member (4) using another clamp mechanism (3). The buoyancy module (7) may also be hollow and comprise an inlet (8) for fluid intake, and an outlet (9) for fluid removal, in order to regulate the weight of the buoyancy module (7).
- 20 In addition, the pump (100) may comprise an inlet (6) for fluid intake from an external source, like the ocean. With the inlet (6), the system may be arranged to transfer fluid out of the pump member (4) via the conduit (5) during wave impact, and when the wave impact subsides, the elongation of the pump member (4) causes the pump (100) to pump in external fluid via the inlet (6).

Claims

1. A pump comprising of an elongating pump member (4) that contains a fluid, where the fluid is displaced by the increase and decrease of volume due to variation of the elongated length of the pump member (4).
5
2. A pump of claim 1 where the varying elongated length of the pump member (4) is caused by ocean surface waves (10) acting directly or indirectly on the pump member (4).
- 10 3. A pump of any one of the preceding claims where the pump member (4) operates with an elongated length of more than 5%, preferably more than 10%, more preferably more than 50%, even more preferably more than 100% of the unstressed length of the pump member.
- 15 4. A pump of any one of the preceding claims where the pump comprises a buoyancy module (7).
5. A pump of claim 4 where the buoyancy module (7) comprises a fluid inlet (8) and a fluid outlet (9).
20
6. A pump of any one of the preceding claims where the pump comprises at least one inlet (6) for fluid intake into the pump member (4) from an external fluid source.

-5-

Figure 1

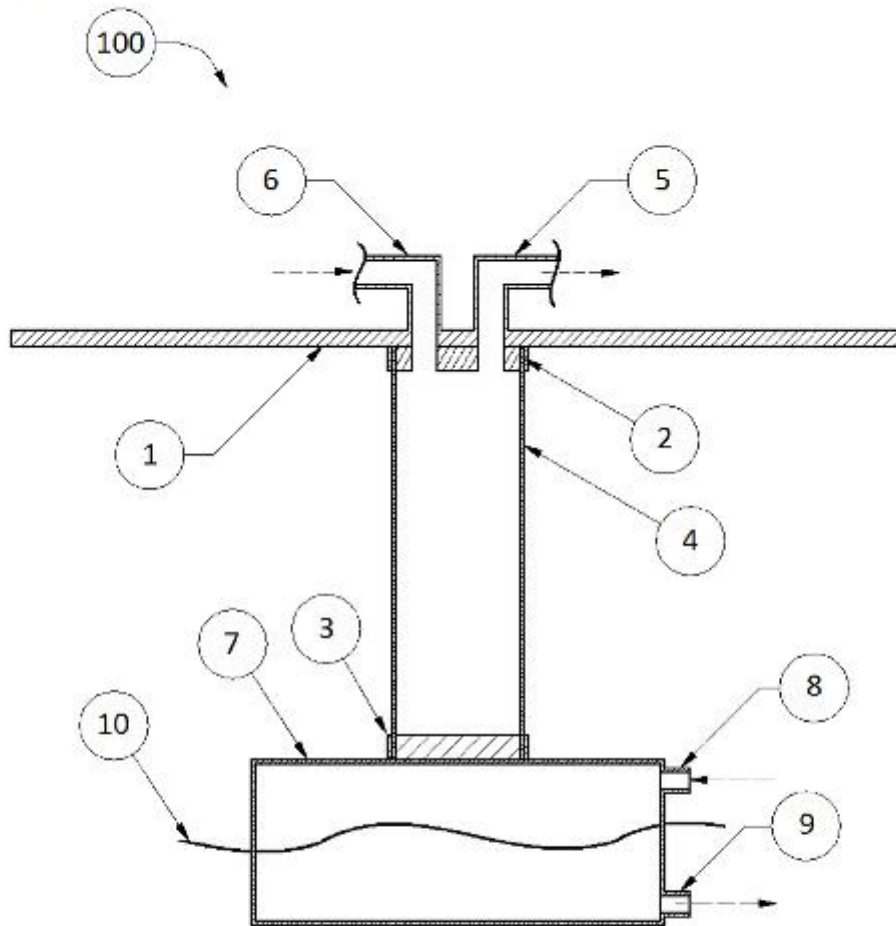

APPENDIX E – CALCULATIONS OF ENVIRONMENTAL CONTOUR METHOD

$$\begin{aligned}
 F_C (h_{wc})^{N_{3h}} &= 0.75 \\
 F_C (h_{wc}) &= 0.75^{\frac{1}{N_{3h}}} \\
 1 - \exp\left(-\left(\frac{h_{wc}}{\alpha_C H_s}\right)^{\beta_C}\right) &= 0.75^{\frac{1}{N_{3h}}} \\
 1 &= 0.75^{\frac{1}{N_{3h}}} + \exp\left(-\left(\frac{h_{wc}}{\alpha_C H_s}\right)^{\beta_C}\right) \\
 \exp\left(-\left(\frac{h_{wc}}{\alpha_C H_s}\right)^{\beta_C}\right) &= 1 - 0.75^{\frac{1}{N_{3h}}} \\
 -\left(\frac{h_{wc}}{\alpha_C H_s}\right)^{\beta_C} &= \ln\left(1 - 0.75^{\frac{1}{N_{3h}}}\right) \\
 \left(\frac{h_{wc}}{\alpha_C H_s}\right)^{\beta_C} &= -\ln\left(1 - 0.75^{\frac{1}{N_{3h}}}\right) \\
 \left(\frac{h_{wc}}{\alpha_C H_s}\right) &= \left(-\ln\left(1 - 0.75^{\frac{1}{N_{3h}}}\right)\right)^{\frac{1}{\beta_C}} \\
 h_{wc} &= \alpha_C H_s \left(-\ln\left(1 - 0.75^{\frac{1}{N_{3h}}}\right)\right)^{\frac{1}{\beta_C}} \\
 h_{wc} &= 0.383 \cdot 13.5 \left(-\ln\left(1 - 0.75^{\frac{1}{919}}\right)\right)^{\frac{1}{1.885}} \\
 h_{wc} &= 15.7 [m]
 \end{aligned}$$

APPENDIX F – TECHNICAL DRAWINGS OF THE PROTOTYPE

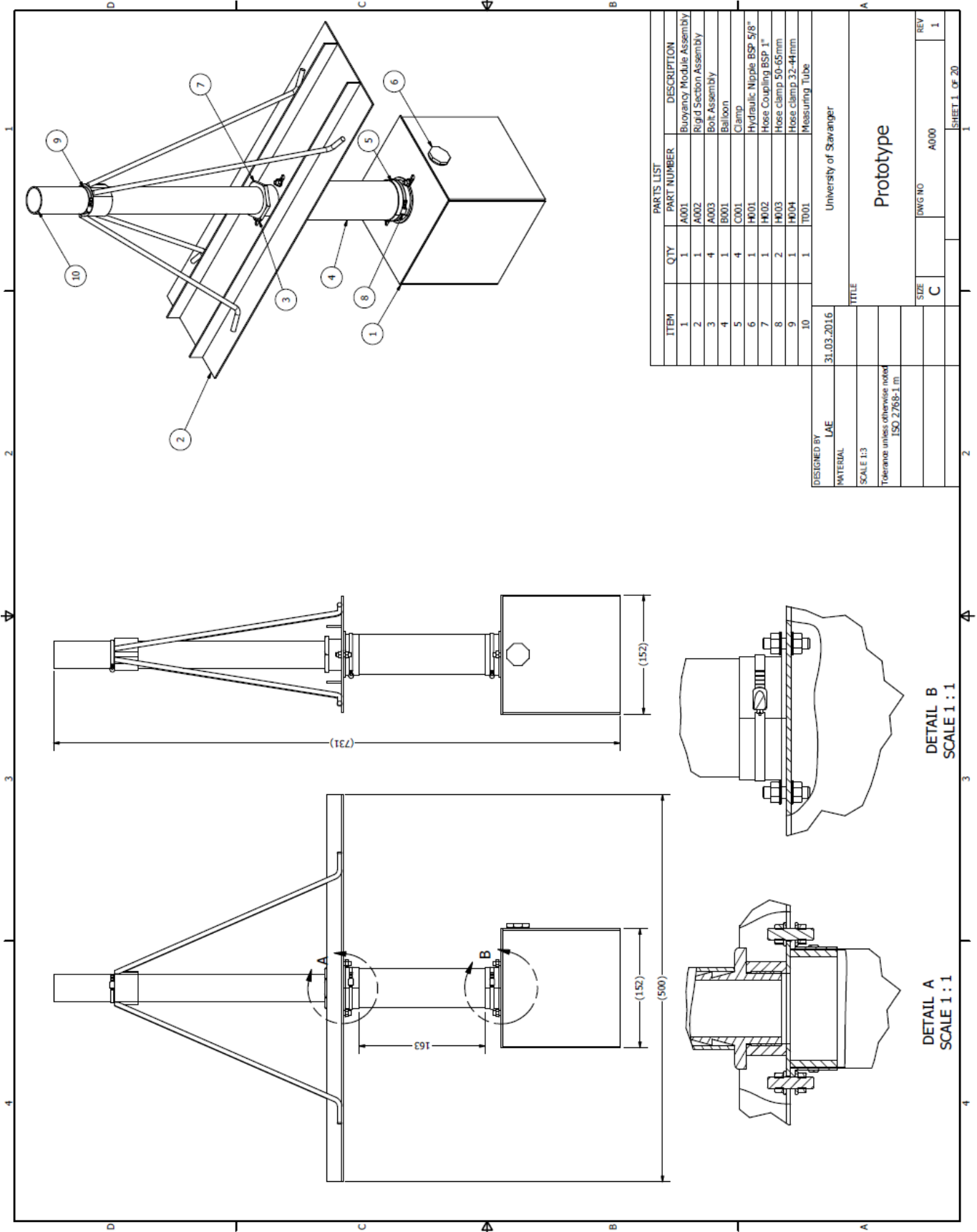

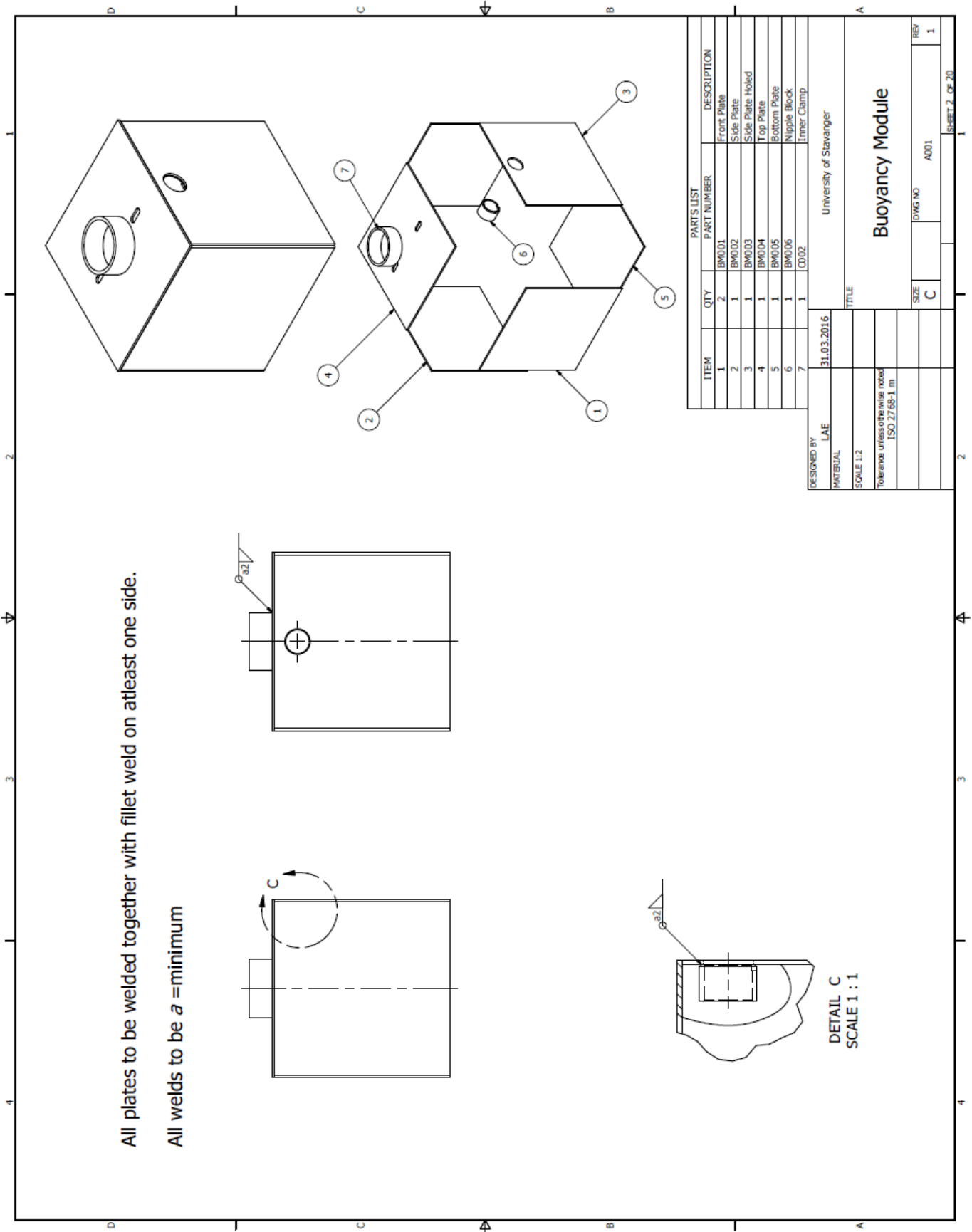

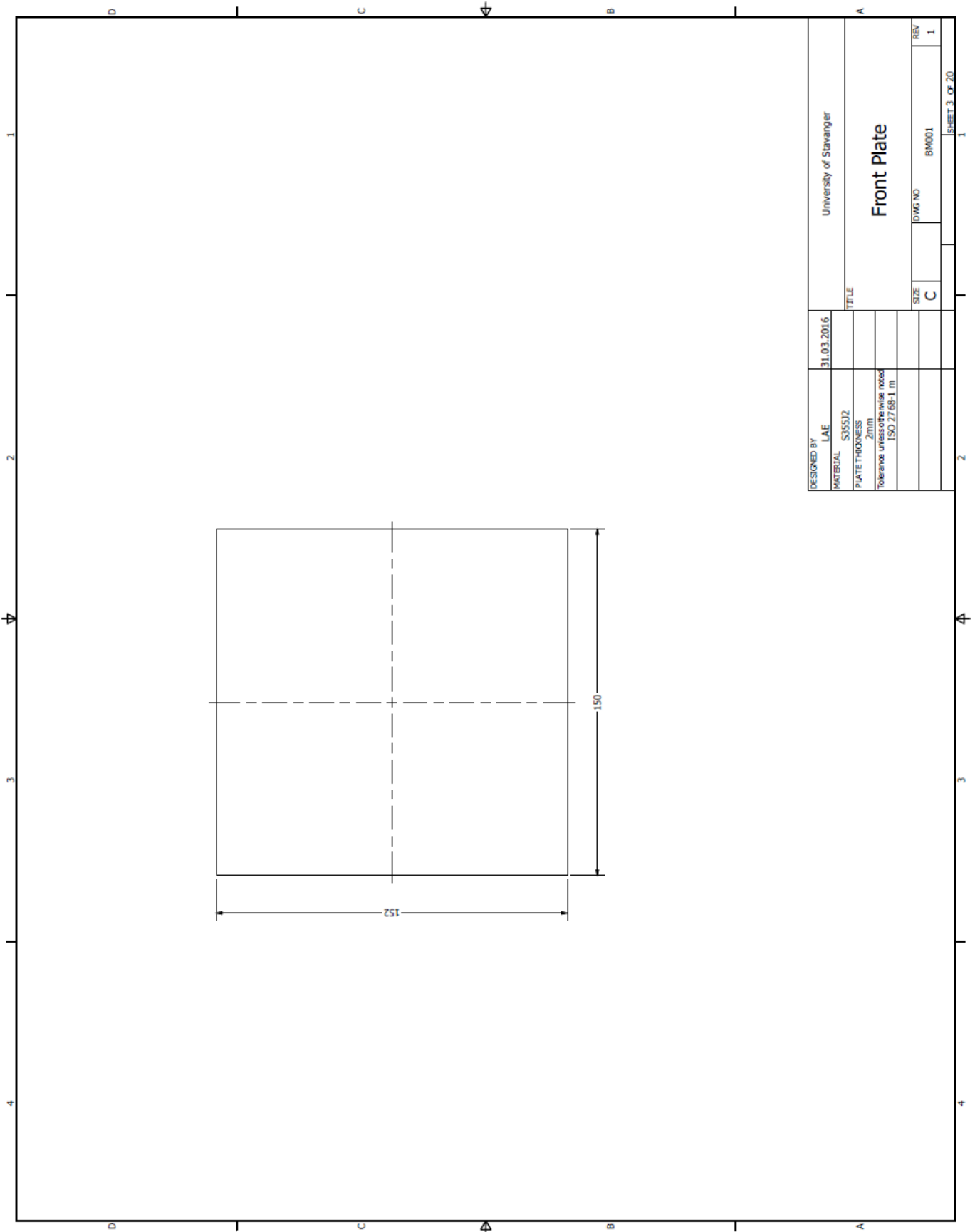

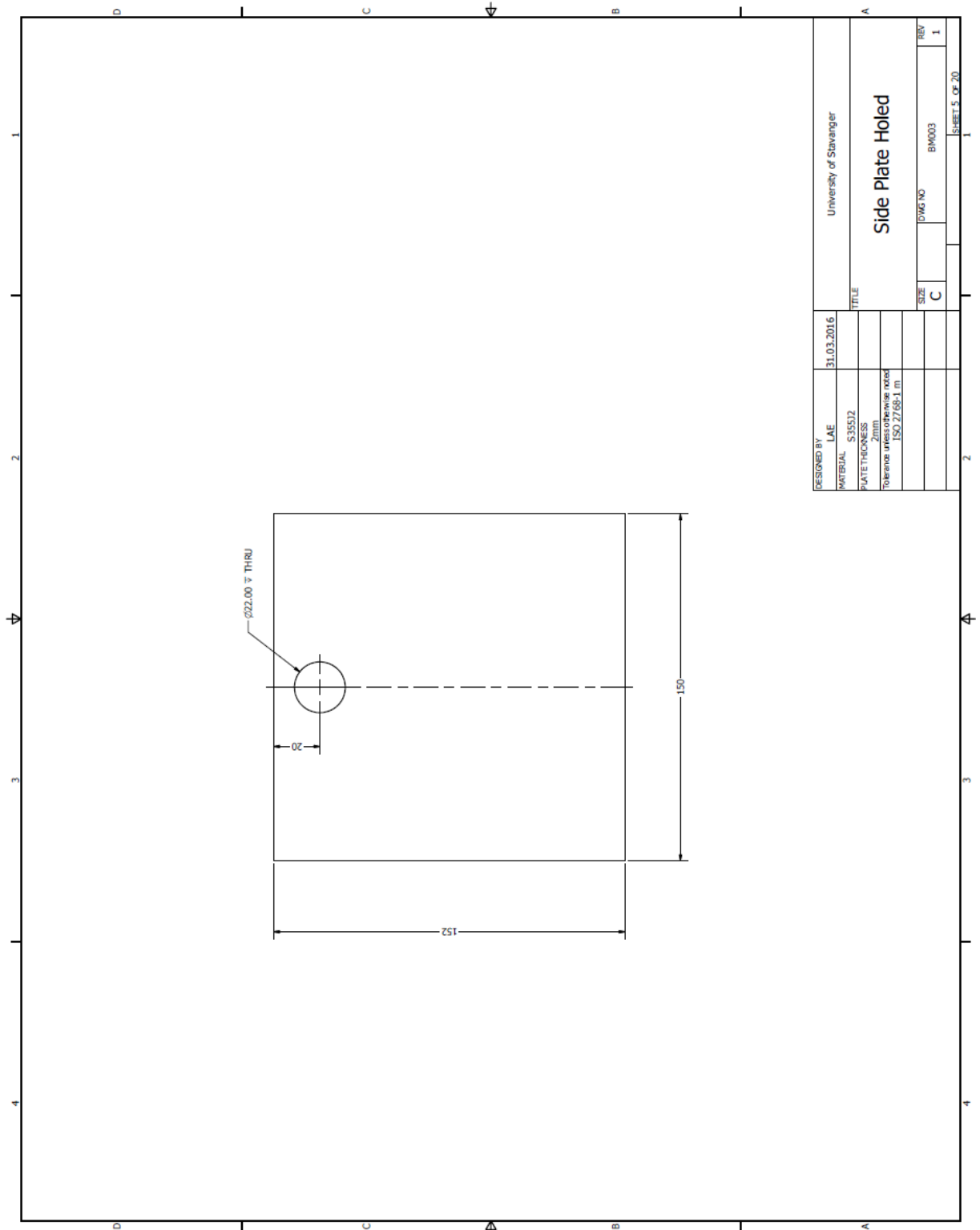

DESIGNED BY	LAE	31.03.2016	University of Stavanger
MATERIAL	S335J2		
PLATE THICKNESS	Zimm		
Reference standard	ISO 27/28-1		
SIZE	C		
DWG NO	BMC03		
REV	1		

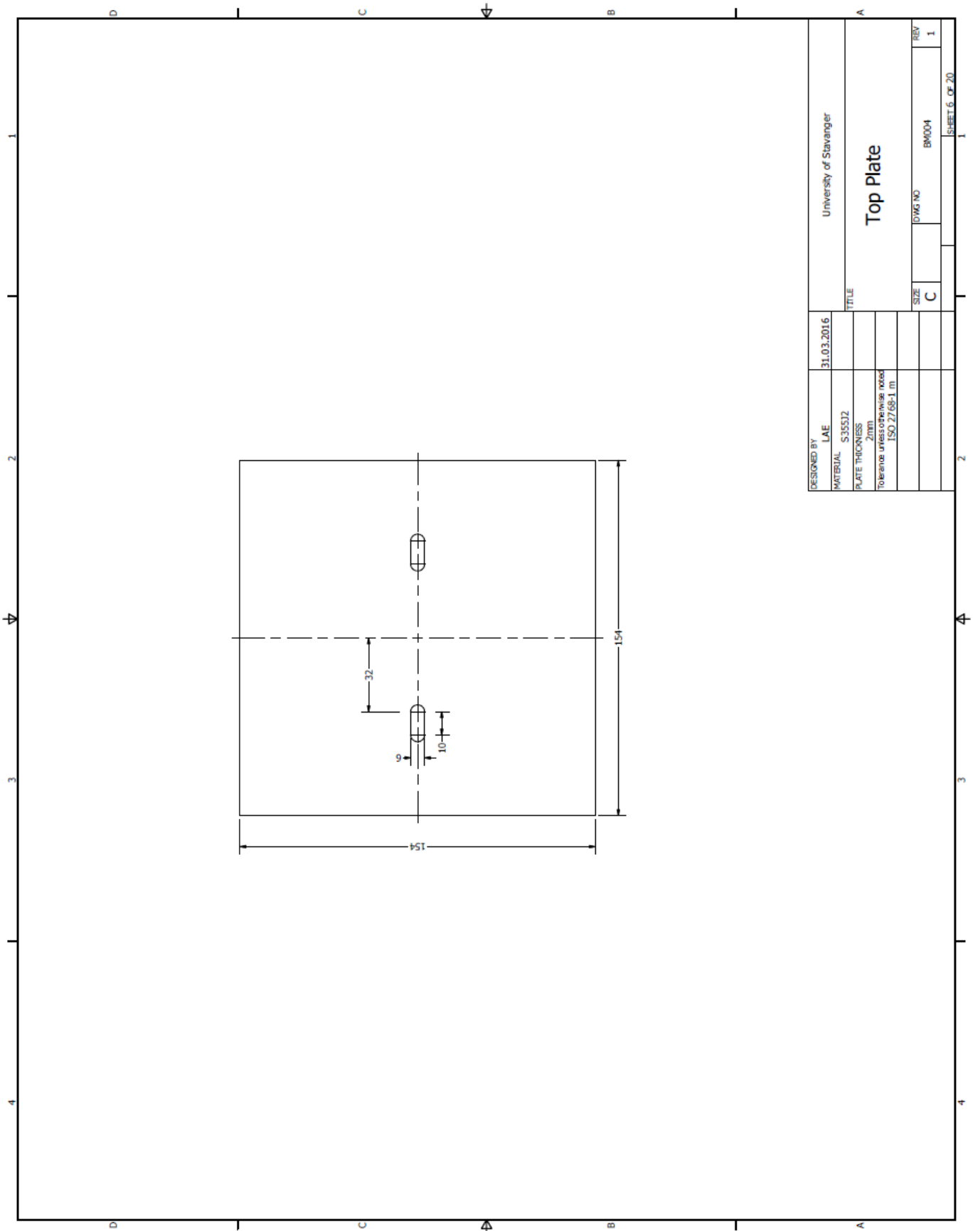

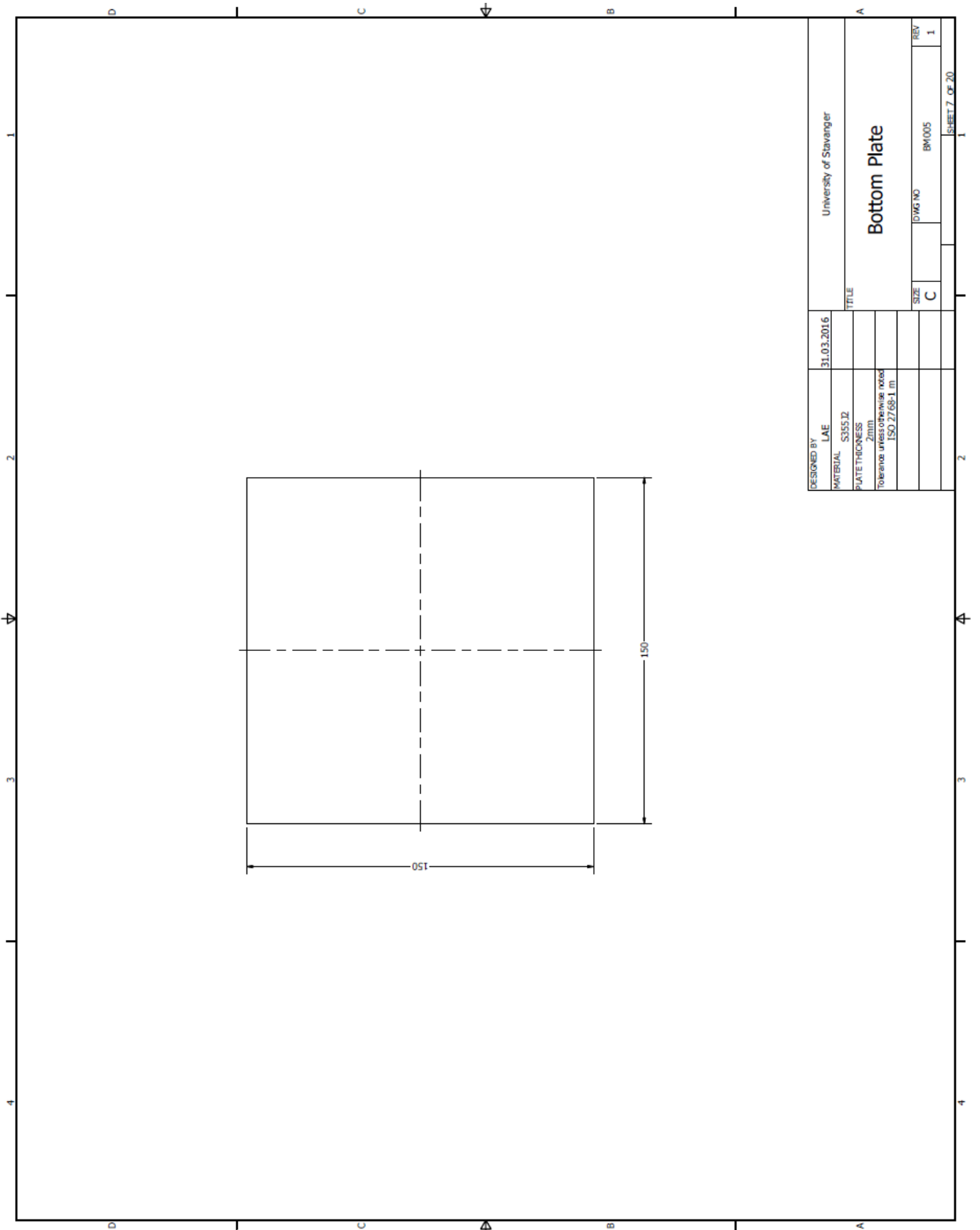

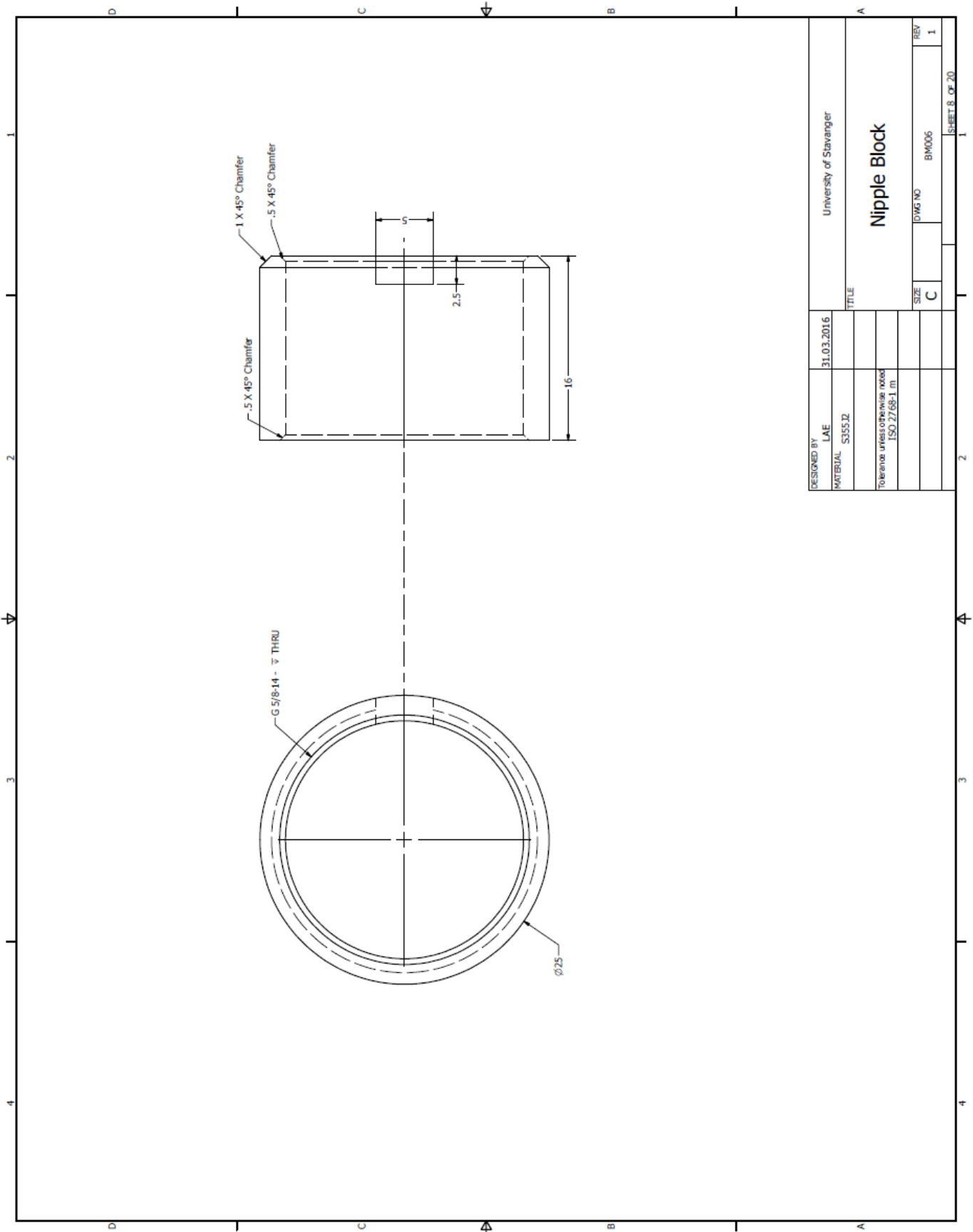

DESIGNED BY	LAE	31.03.2016	University of Stavanger
MATERIAL	S355J2		
Tolerances unless otherwise noted ISO 2758-1 m			
SIZE	C	DWG NO	BM006
REV	1		

Nipple Block

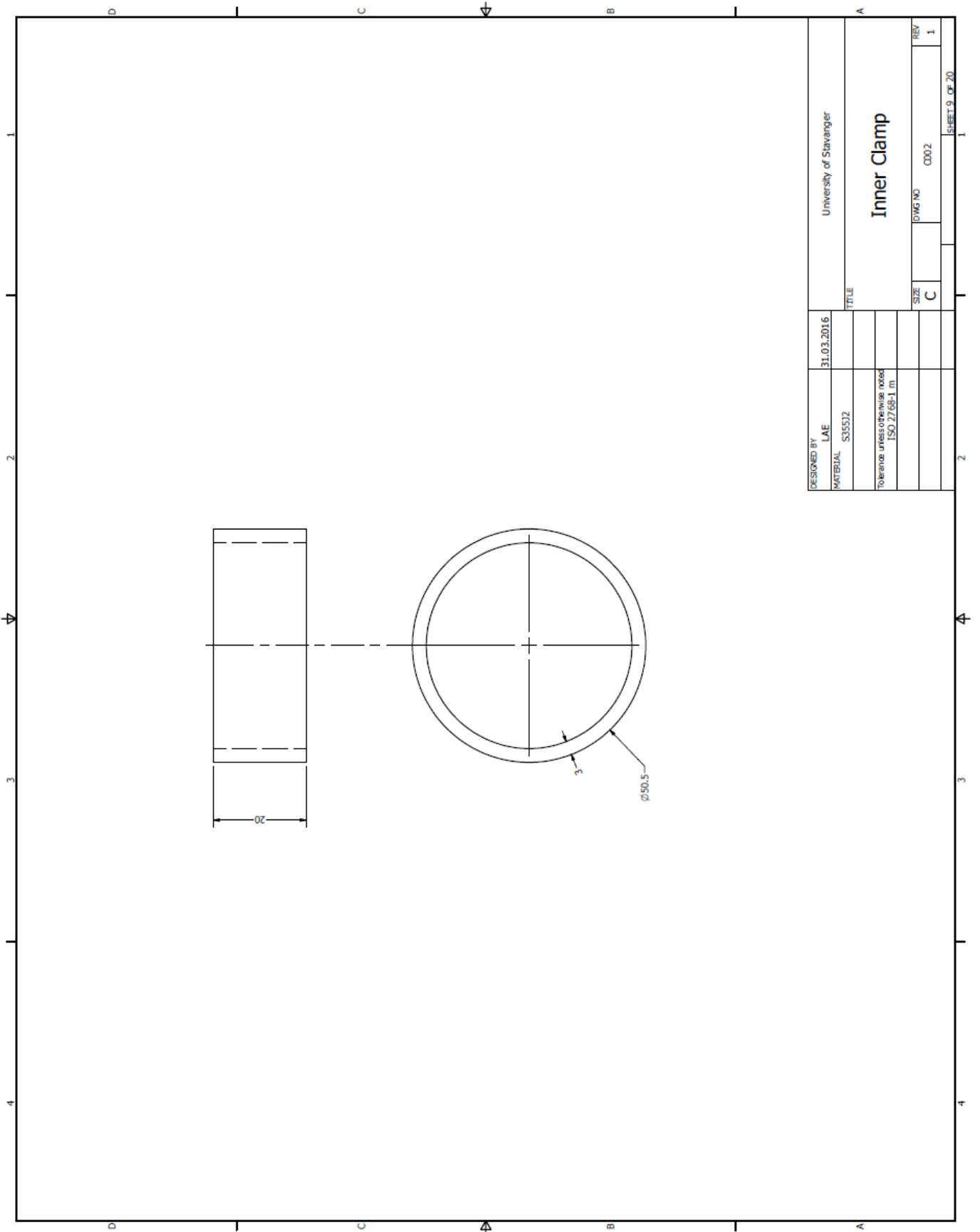

DESIGNED BY	LAE	31.03.2016	University of Stavanger
MATERIAL	S355J2		
Tolerances unless otherwise noted ISO 2768-1 m			
SIZE	C	DWG NO	C002
REV	1		

SHEET 9 OF 20

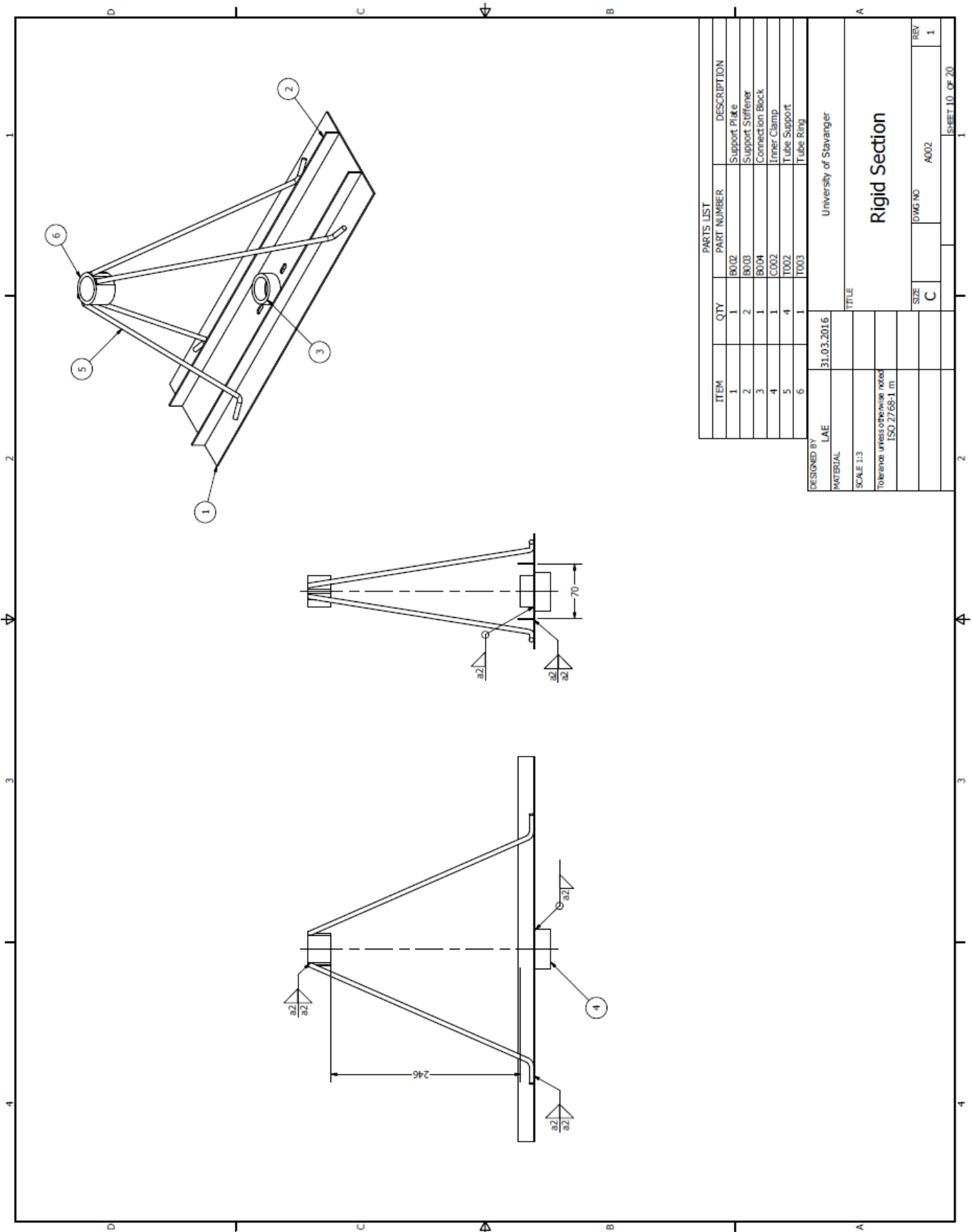

PARTS LIST	
ITEM	DESCRIPTION
1	Support Plate
2	Support Stiffener
3	Connection Block
4	Inner Clamp
5	Tube Support
6	Tube Ring

DESIGNED BY	LAE	31.03.2016	University of Stavanger
MATERIAL			
SCALE	1:3		
Tolerances	unless otherwise noted ISO 2768-1 m		
SIZE	C	DWG NO	A002
REV	1	SHEET 10 OF 20	

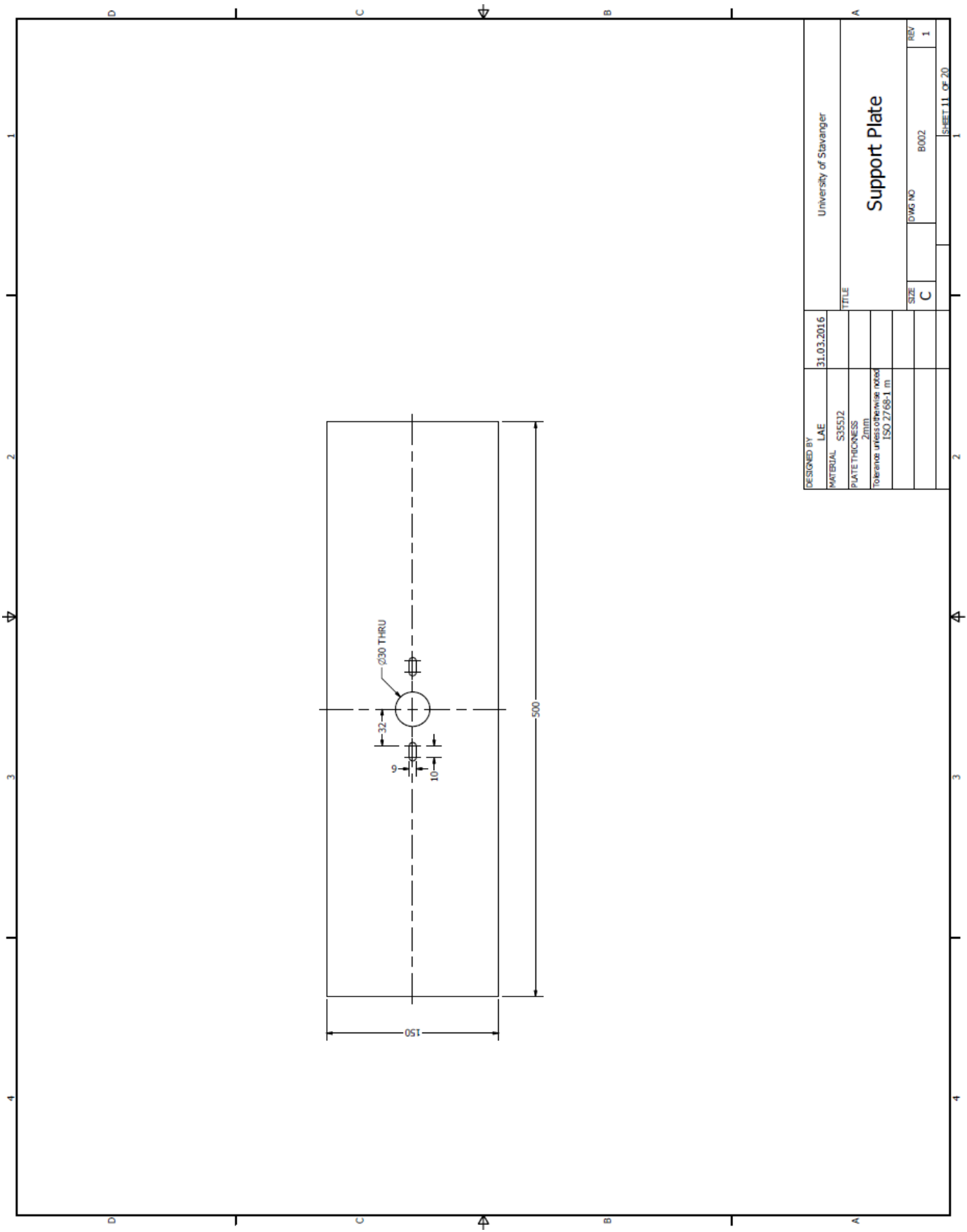

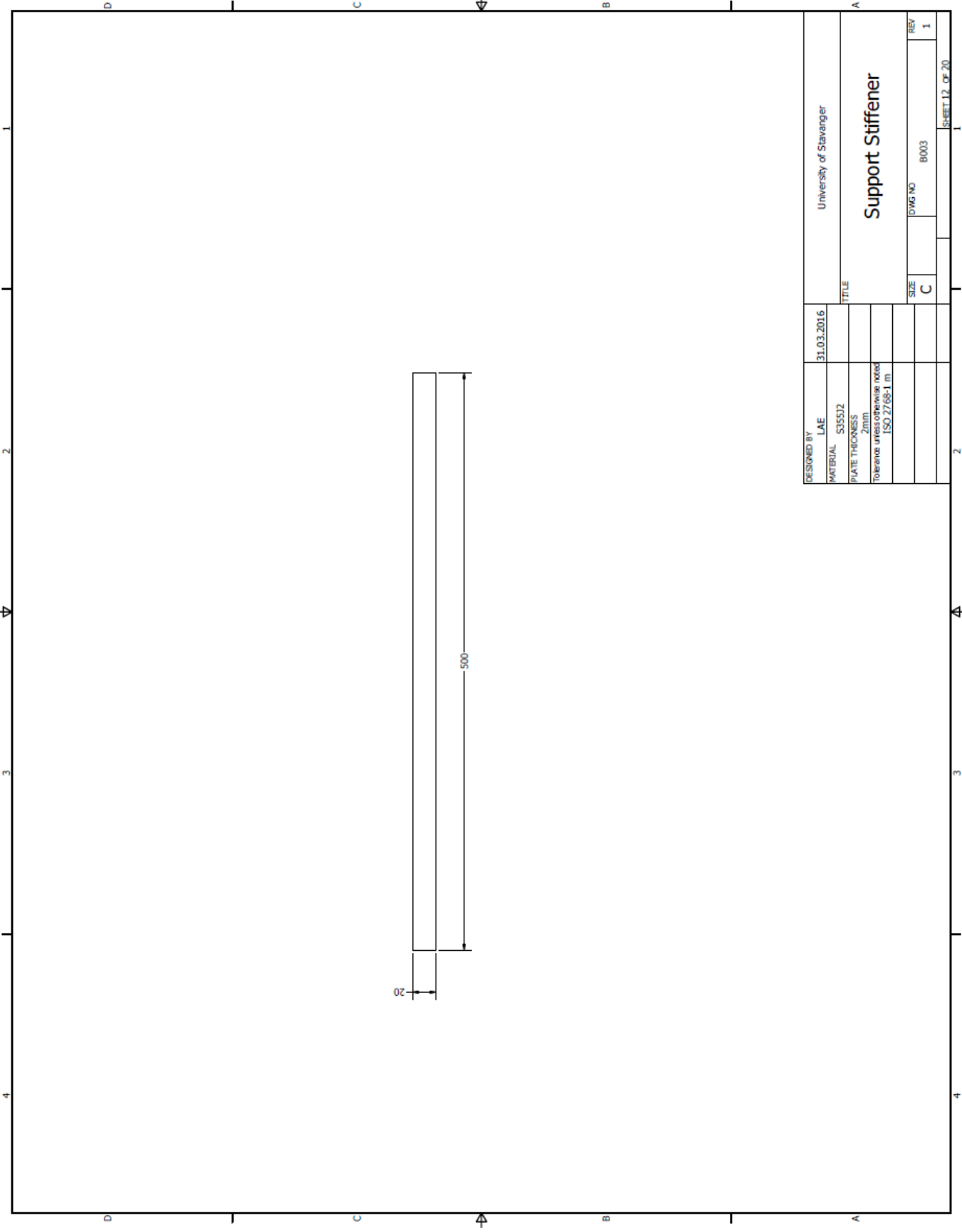

DESIGNED BY	LAE	31.03.2016	University of Stavanger
MATERIAL	S355J2		
PLATE THICKNESS	2mm		
Tolerance unless otherwise noted	ISO 2768-1 m		
TITLE	Support Stiffener		
SIZE	C	DWG NO	B003
REV	1		

SHEET 12 OF 20

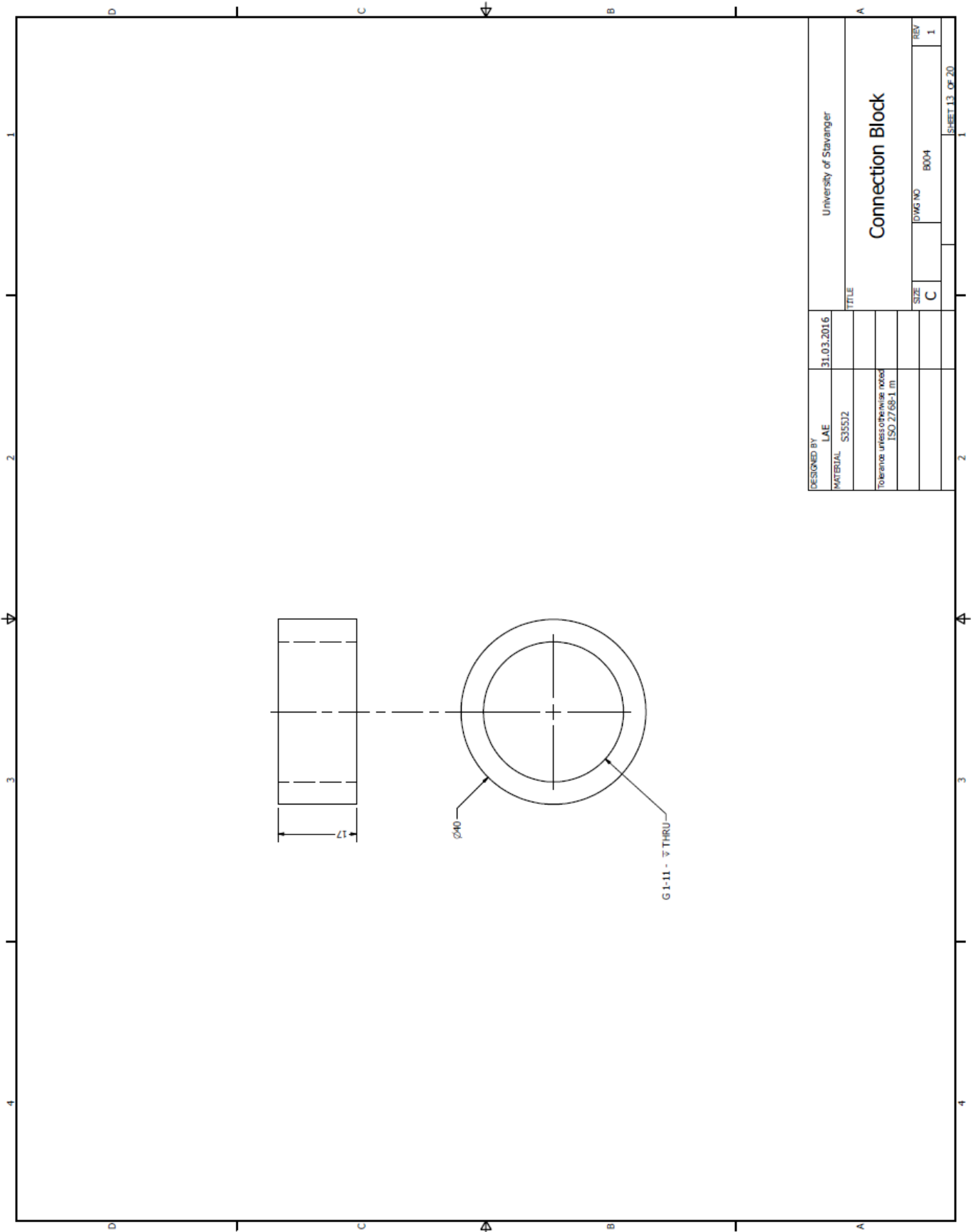

DESIGNED BY	LAE	31.03.2016	University of Stavanger
MATERIAL	S355J2		
Tolerances unless otherwise noted ISO 2768-1 m			
SIZE	C	DWG NO	B004
REV	1		

Connection Block

SHEET 13 OF 20

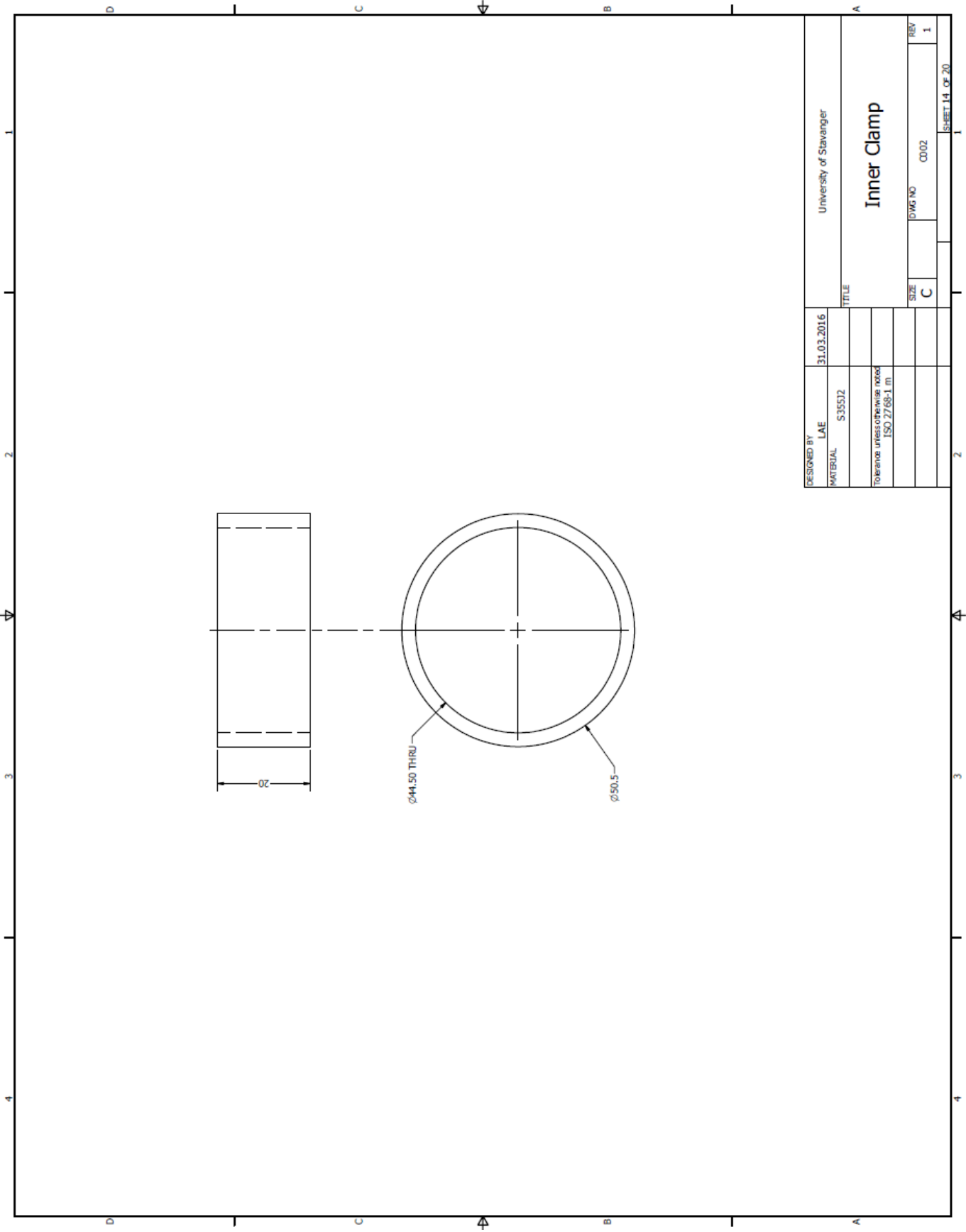

DESIGNED BY	LAE	31.03.2016	University of Stavanger
MATERIAL	S355J2		
Tolerances unless otherwise noted ISO 2768-1 m			
SIZE	C	DWG NO	CO02
REV	1		

Inner Clamp

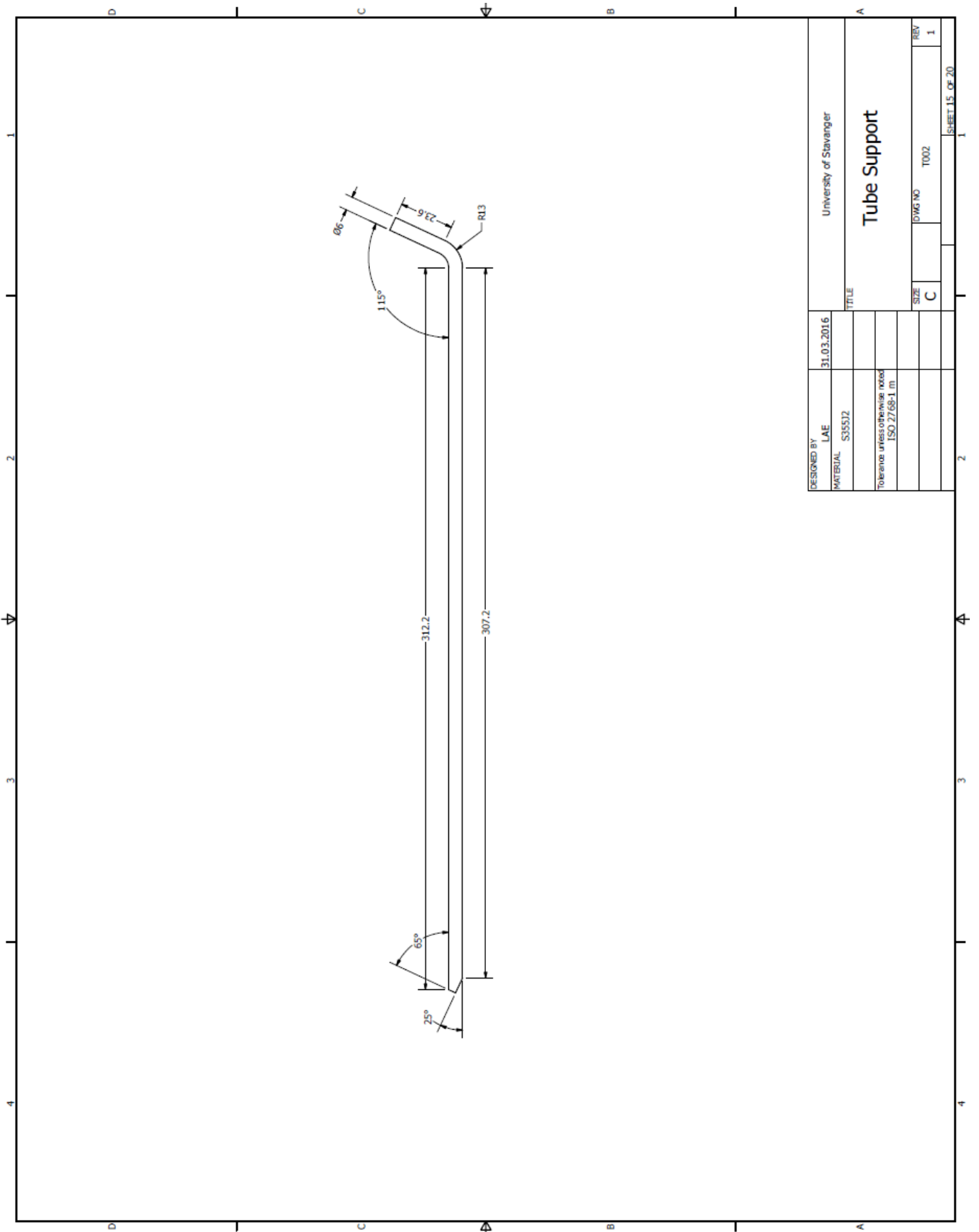

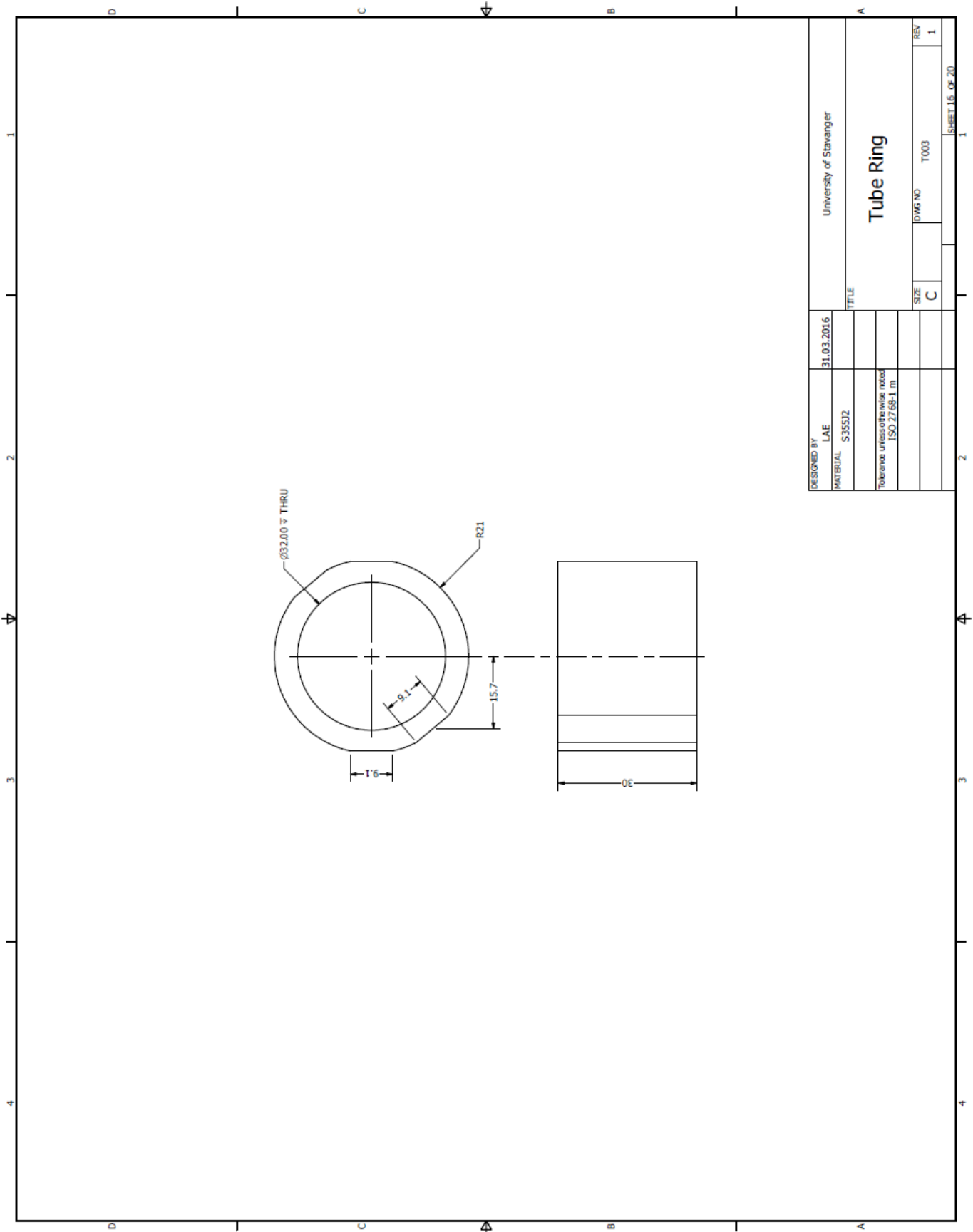

DESIGNED BY	LAE	31.03.2016	University of Stavanger
MATERIAL	S355J2		
Tolerances unless otherwise noted ISO 2758-1 m			
SIZE	C	DWG NO	T003
REV	1		

SHEET 16 OF 20

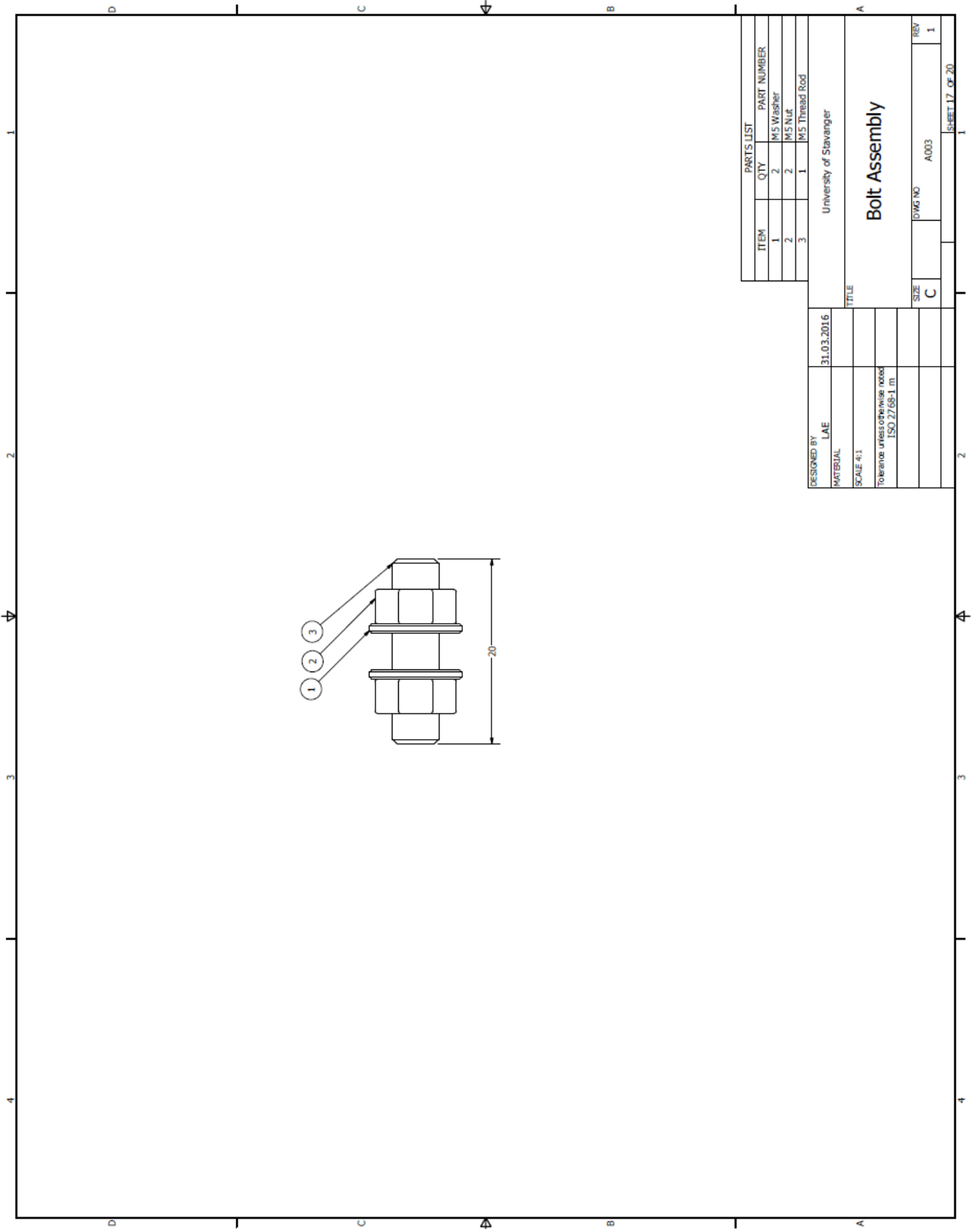

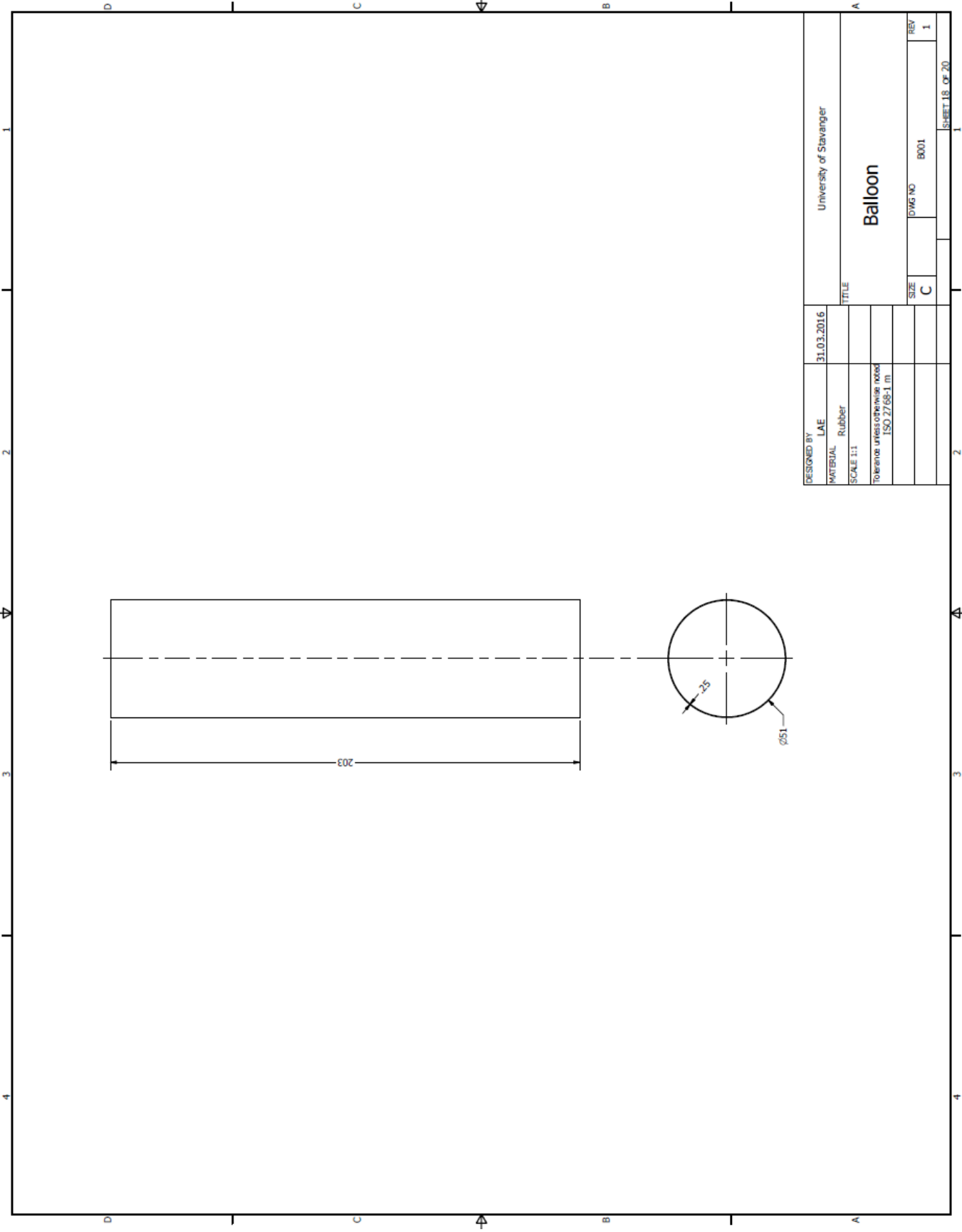

DESIGNED BY	LAE	31.03.2016	University of Stavanger
MATERIAL	Rubber		
SCALE	1:1		
Tolerance unless otherwise noted ISO 2758-1 m			
		SIZE	C
		DWG NO	B001
		REV	1

Balloon

SHEET 18 OF 20

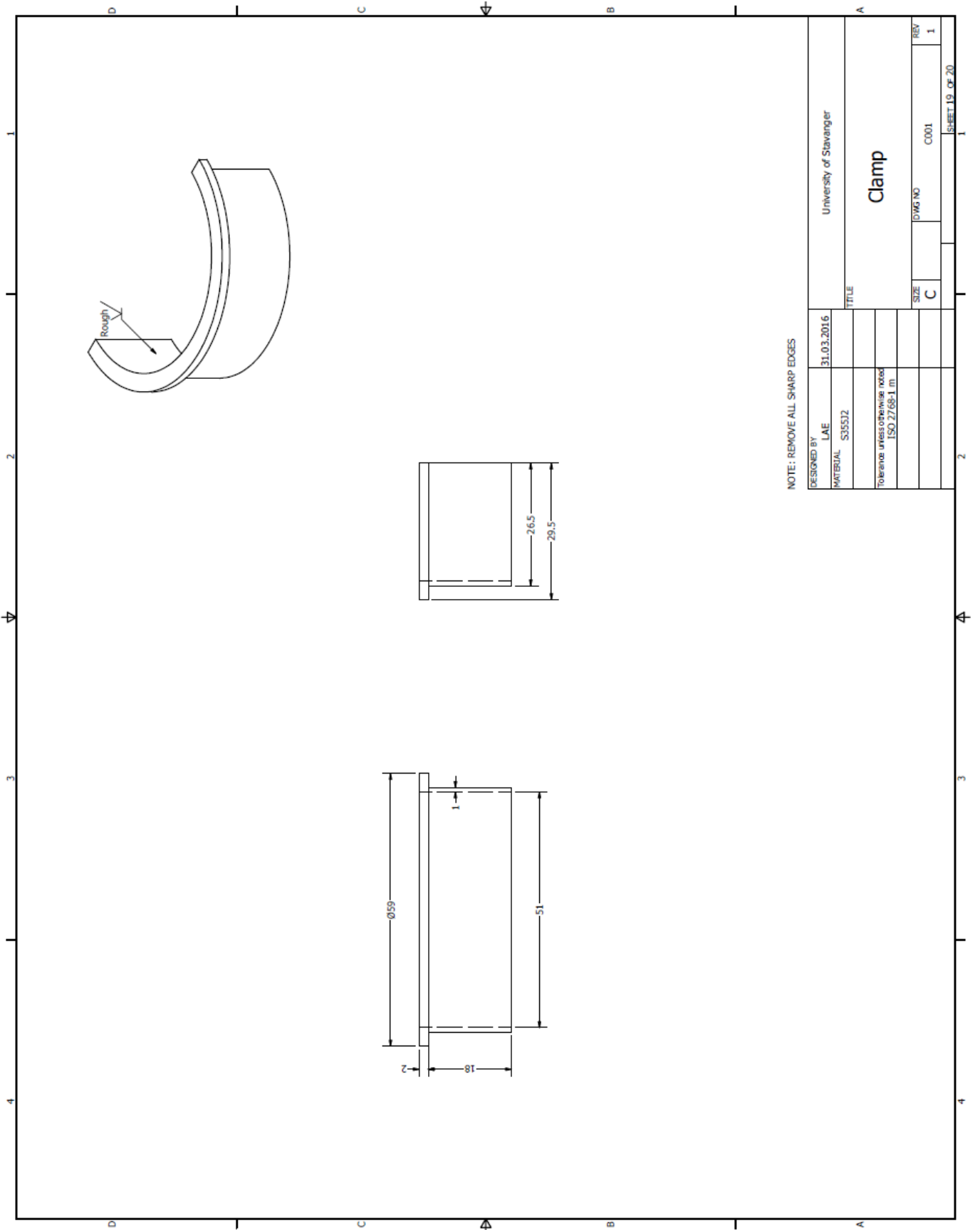

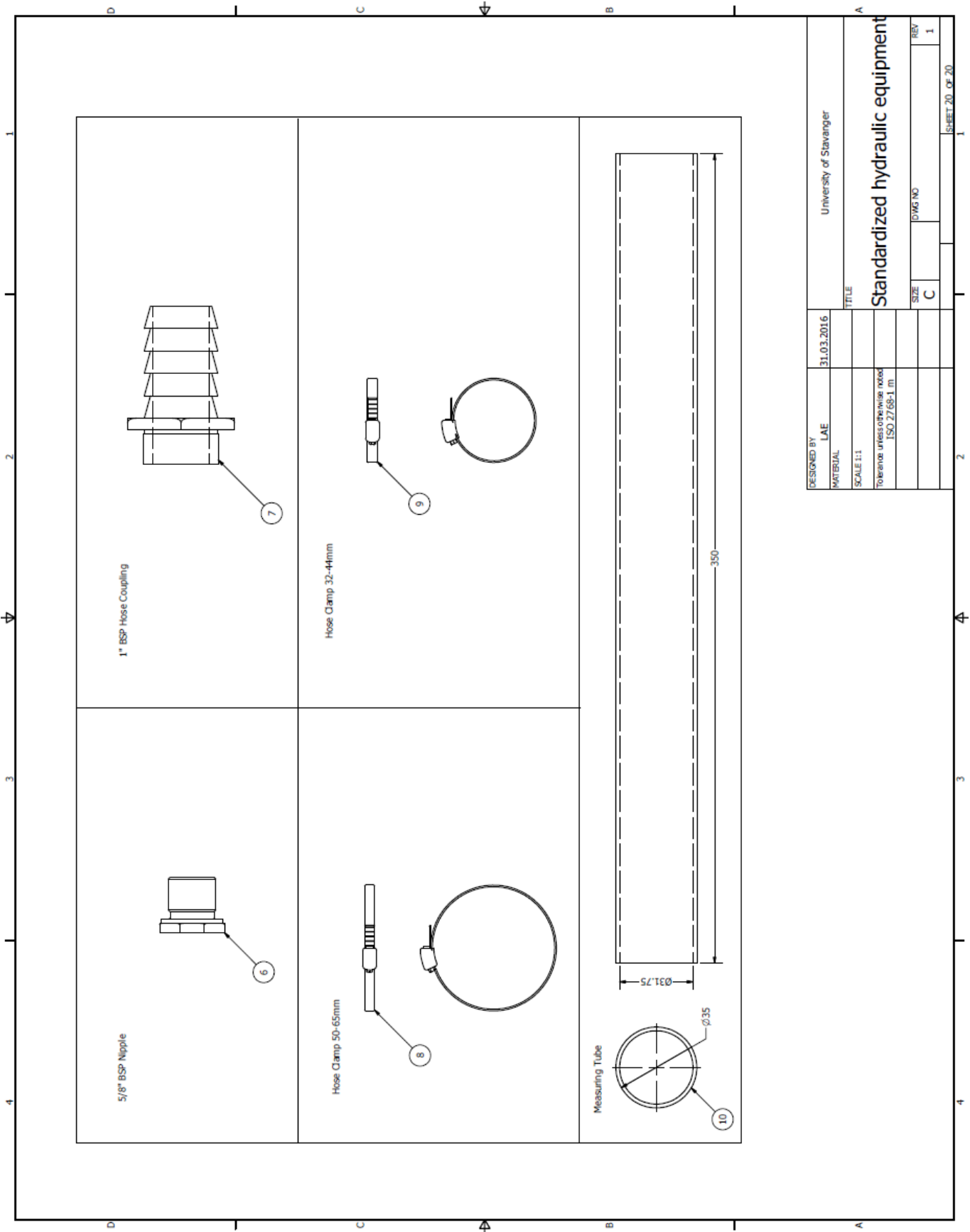

DESIGNED BY	LAE	31.03.2016	University of Stavanger
MATERIAL			
SCALE 1:1			
Tolerance unless otherwise noted ISO 27/58-1 in			
SIZE	C	DWG NO	
REV	1		

Standardized hydraulic equipment

SHEET 20 OF 20