



Faculty of Science and Technology

Master Thesis

Study program/Specialization: Offshore Technology/Marine and Subsea Technology	Spring semester, 2016 Open
Writer: Nadezhda Zheleva (Writer's signatures)
Faculty supervisor: Ole-Erik Vestøl Endrerud External supervisor:	
Title of thesis: “Challenges in Subsea Structures Design – Dropped Objects Analysis of Multiwell Template/manifold System”	
Credits (ECTS): 30	
Key words: FMECA Risk matrix Subsea system Dropped objects Template/manifold	Pages: 49 + enclosure: 25 Stavanger, 15.06.2016

ACKNOWLEDGEMENTS

Firstly I would like to thank my supervisor Ole-Erik Vestøl Endrerud, PhD student at University of Stavanger, for his supervision and support throughout my work and for valuable input in completing my master thesis. Also, I would also like to thank my friend Shivam for been helpful with answering my questions and providing me competence comments whenever needed.

ABSTRACT

Nowadays, the production of oil and gas has a major importance to the stability of the world's energy supply. Almost 80 percent of the world's energy consumption comes from fossil fuels (oil, gas, and coals), and around 30 percent of these fuels comes from offshore fields and will continue to increase in the future. Developing and exploration of the offshore fields lead to increasing the subsea facilities installed and the number of marine operations. Every offshore activity entails a risk of accidents with severe consequences. A great number of accidents are caused by falling free objects. This results in a damage of the subsea facilities and leads to a loss of containment, production time and financial assets. In some areas of the world, the regulations and legislations require a protection of the subsea system against dropped objects impact. In these regions multiwell template/manifold system is widely used as a part of subsea production system.

The main focus in this thesis is an estimation of the most critical components of the multiwell manifold/template system, with respect to the production if the system is exposed to dropped objects impact. For the purpose of the analysis, Failure Mode, Effects and Criticality Analysis (FMECA) is carried out. All the system elements are estimated and analyzed and according to their failure rate and severity of occurrence, they are plotted in a risk matrix. The most critical components, which have significant importance for the system reliability and performance, are obtained according to the risk level identification in the risk matrix.

The results derived from the analysis indicate that the template protective structure is the most critical unit in the system. A failure of the template may lead to damage of the equipment, which is important for the reliability of the system and the production of hydrocarbons. Thus the protection structure design is necessary for the subsea structures to ensure the safety of the system during installation and exploitation, and to minimize the risk.

TABLE OF CONTENTS

ACKNOWLEDGEMENTS.....	I
ABSTRACT.....	II
TABLE OF CONTENTS.....	III
LIST OF FIGURES	V
LIST OF TABLES	VI
LIST OF SYMBOLS	VII
TERMINOLOGY	VIII
1 CHAPTER: INTRODUCTION	1
1.1 BACKGROUND	1
1.2 PROBLEM FORMULATION	1
1.3 OBJECTIVES.....	2
1.4 STRUCTURE OF THE THESIS	3
2 CHAPTER: THEORITICAL BACKGROUND.....	5
2.1 DROPPED OBJECTS	5
2.2 FMECA	6
2.2.1 Reliability method.....	7
2.2.2 Reliability data	7
2.2.3 Failure modeling	9
2.3 RISK MATRIX	12
2.4 SUBSEA SYSTEM DESCRIPTION	13
2.4.1 Main components	13
2.4.2 Subsea system layouts and design aspects	25
2.4.3 Functional requirements.....	28
2.4.4 Installation of subsea multiwell template/manifold	29
2.5 STANDARDS AND REGULATIONS.....	30
3 CHAPTER: METHODOLOGY	31
3.1 ASSUMPTIONS	31

3.2 ANALYSIS PROCEDURE.....	32
4 CHAPTER: RESULTS.....	35
5 CHAPTER: DISCUSSIONS	43
6 CHAPTER: CONCLUSIONS AND RECOMENDATIONS	48
REFERENCES	50
APPENDIX A.....	52
APPENDIX B	54

LIST OF FIGURES

Figure 1: The bathtub curve (Rausand, et al., 2004).....	10
Figure 2: Template/manifold interface (Jansen, 2013).....	14
Figure 3: Template (Subsea 1 AS, 2013).....	14
Figure 4: Template interface (Subsea 1 AS, 2013).....	15
Figure 5: Manifold (Subsea 1 AS, 2013).....	16
Figure 6: Manifold interface (Subsea 1 AS, 2013).....	17
Figure 7: Xmas tree (Subsea 1 AS, 2013).....	18
Figure 8: Xmas tree interface (Subsea 1 AS, 2013).....	18
Figure 9: Subsea control module (Subsea 1 AS, 2013).....	19
Figure 10: Subsea control module (Subsea 1 AS, 2013).....	20
Figure 11: Flow control module (Subsea 1 AS, 2013).....	20
Figure 12: Flow control interface (Subsea 1 AS, 2013).....	21
Figure 13: Pigging launcher (Petrowiki, 2015).....	22
Figure 14: Subsea gate valve (Worldwide Oilfield Machine, 2016).....	23
Figure 15: Typical two – way subsea ball valve (Parker-Hannifin Inc., 2016).....	24
Figure 16: Flowline connector (FMC Technologies, 2006).....	24
Figure 17: Stand – alone manifold template (cluster) (Jansen, 2013).....	25
Figure 18: Multiwell manifold/template (Jansen, 2013).....	26
Figure 19: Summary of the risk level distribution.....	39
Figure 20: Distribution of the failure modes in high risk level region.....	40
Figure 21: Distribution of the failure modes in medium risk level region.....	41
Figure 22: Distribution of the failure modes in low risk level region.....	42
Figure 23: Breakdown structure of the system.....	53

LIST OF TABLES

Table 1: Failure rate classification	10
Table 2: Severity classification	11
Table 3: Severity classification	11
Table 4: Total risk	12
Table 5: Example of a risk matrix	13
Table 6: Risk matrix (Operational risk)	36
Table 7: Summary of the components' risk level	37
Table 8: Summary of the risk level evaluation	38
Table 9: FMECA	54

LIST OF SYMBOLS

ALARP	As Low As Reasonable Practicable
AVB	Annulus valve block
BOP	Blow out preventer
FCM	Flow control module
FMEA	Failure mode and effects analysis
FMECA	Failure mode, effects, and criticality analysis
HIPPS	High integrity pressure protection system
HPU	Hydraulic power unit
OREDA	Offshore reliability data
PC	Protection cover
PFL	Production flow loop
PMV	Production master valve
PVB	Production valve block
ROV	Remote operated vehicle
SCM	Subsea control module
VCM	Vertical connection module
WVB	Wing valve block
XMT	Christmas tree
XOFL	Crossover flow loop
XOV	Crossover valve

TERMINOLOGY

Accident	An unintended event or sequence of events that causes death, injury, environmental, or material damage.
Downtime	the period of time during which an item is not in a condition to perform its required function
Failure	termination of the ability of an item to perform a required function.
Failure mechanism	physical, chemical or other processes which lead or have led to failure.
Failure mode	effect by which a failure is observed on the failed item.
Failure rate	number of failures relative to the corresponding operational time.
Fault	state of an item characterised by inability to perform a required function, excluding the inability during preventive maintenance or other planned actions, or due to lack of external resources.
Hazard	situation that could occur during the lifetime of a product, system or plant that has the potential for human injury, damage to property, damage to the environment, or economic loss.
Reliability	the ability of an item to perform a required function, under given conditions and for a given time interval.
Repair time	that part of active corrective maintenance item during which repair is carried out on an item.
Risk	combination of the probability, (or frequency) of occurrence of a defined hazard and the magnitude of the consequences of the occurrence.
Severity	the consequences of a failure mode. Severity considers the worst potential consequences of a failure, determined by the degree of injury, property damage, or system damage that could ultimately occur.

1 CHAPTER: INTRODUCTION

A failure of the components in the subsea system can be critical for the oil and gas production. One of the reasons, which may cause these failures are accidents due to free falling objects during marine operations.

1.1 BACKGROUND

Nowadays, around 30 percent of oil and gas production comes from offshore fields and will continue to increase in the future. The high demand of oil and gas has forced the industry to look even deeper below the seabed. More and more subsea fields have been discovered, which have significantly increased the number of subsea facilities installed. Experiences show that the accidents related to subsea facilities, as all other offshore oil and gas activities, have a potential for major accidents, which are critical for the production of the field. Developing, exploration and production of hydrocarbons entail a risk of a catastrophic events with potentially severe consequences to the life and health of workers, pollution of the environment, direct and indirect economic losses, and deterioration of the security of energy supply (Christou & Konstantinidou, 2012).

1.2 PROBLEM FORMULATION

The oil and gas provision has a significant importance for the world's energy supply and for the economics. In recent years, a large amount of the oil and gas production comes from offshore fields. Deep water and ultra-deep water exploration and production have increased significantly, which has lead to an enlargement of the volume of the subsea facilities installed and increased the challenges in marine operations.

Offshore developing and exploration is related to very hazardous and risky operations. Many various accidents may occur during different offshore activities. A major part of these accidents are caused by accidental collisions and third party activities. Accidents due to falling free object during marine operation are considered to be the main cause among all accidental loads, which lead to production cease (Sari, et al., 2016). A dropped object can be any object that falls from its initial static position under its own weight and may cause death, injury or/and equipment damage (Leong, 2012). Dropped objects may have different shapes

and sizes, hence different impact load and impact energy. Impact from dropped objects is a typical accidental action and should be considered when an accidental limit state design is carried out. In lifting zone nearby platforms or tankers, a protective structure is necessary to protect the subsea equipment from impact load caused by dropped objects. These subsea structures are very vulnerable and difficult to repair; damage on some of the components may be critical and may lead to loss of production time and financial losses. So the protection structure design is necessary for all the subsea structures. The main purpose of the design is to ensure the safety of the system during installation and exploitation, and to minimize the risk. A safe design for offshore assets for accidental loads require a risk assessment for such an event (Sari, et al., 2016). In any risk assessment the frequency of the risk and the consequences of the event should be evaluated. A very powerful tool in reliability analysis for evaluation of the risk and criticality of the system is Failure Mode, Effects, and Criticality Analysis (FMECA). Using this approach, the consequences of an accidental collision event can be assessed in terms of human fatalities, asset damage, environmental impact and/or a reputation. For the criticality assessment of subsea exploration and production facilities, the consequences in terms of loss of production and production time are of interest.

In subsea field development, in areas, where third party activities protection is required, multiwell manifold/template system is widely used. In order to prevent failures of the system and the equipment, it is important to understand the purpose of the system and to determine the most critical components and their functions, because failures of some of the components can lead to severe consequences for the reliability of the system and the production of hydrocarbons, which will lead to loss of production time and financial assets.

1.3 OBJECTIVES

Main objective of this master thesis is an estimation of the most critical components of the multiwell manifold/template system, whom failure will cause stopping the production of hydrocarbons if it is exposed to dropped objects impact. For this purpose, FMECA is used to analyze the components of the system and a risk matrix is conducted to estimate the criticality level of the system. Main activities performed are:

- Review of the dropped objects impact on subsea structures;
- Review of the FMECA reliability method;
- Identification of the template/manifold system components and their function;

- Performance of FMECA of the template/manifold system;
- Performance of a risk matrix;
- Analyzing the results derived from FMECA and the risk matrix;
- Obtaining of the most critical components based on the analysis.

1.4 STRUCTURE OF THE THESIS

The main purpose of this thesis is to analyze the influence of dropped objects if they fall onto a subsea multiwell manifold/template and the consequences this may have on the production of hydrocarbons. The report is organized in six chapters as follows:

1	INTRODUCTION	Consists of background, problem formulation, and main objectives.
2	THEORITICAL BACKGROUND	Consists of introduction of dropped objects theoretical background, description of FMECA procedure, risk matrix, a description of the subsea system, and main standards and regulation used in subsea structure design and risk analysis.
3	METHODOLOGY	Consists of assumptions made to perform the analysis and sequences of the procedure.
4	RESULTS	Consists of a breakdown structure of the system, a FMECA sheet, a risk matrix.
6	DISCUSSIONS	Consists of analysis of the results obtained from FMECA and the risk matrix.
5	CONCLUSIONS AND RECOMENDATIONS	Consists of conclusions made due to the analysis of the results and recommendations for further work.

First chapter is an introduction to the main problem analyzed in the report. It gives description of the problem due to falling free objects that can occur during installation, intervention and/or production of oil and gas, discusses the need of FMECA analysis and why this problem is important for the industry. *Second chapter* presents a brief theory of dropped object study, a description of FMECA reliability method, a reliability data source, failure modeling, what is a risk matrix and how it is used for the purpose of the analysis. To understand the purpose of the template/manifold and its functions, in this chapter a typical

subsea production system is also described including main components, different layouts, design aspects, functional requirements, installation method, and main standards used in the subsea structure design and risk analysis. **Third chapter** is a review of the methodology used in the thesis. Here, the assumptions made to perform the analysis are listed and the FMECA procedure is described. In **fourth chapter** the breakdown structure of the system is obtained and all the system components that are exposed to falling objects are identified. FMECA sheet is conducted; all failures and their effect on the system are described and evaluated using failure rate and severity ranking. All the components are plotted in the risk matrix according to their failure rate and severity. In **fifth chapter** the analysis of the results obtained from FMECA and the risk matrix are discussed. Last **sixth chapter** contains the conclusions based on the analysis performed in the thesis and recommendations for further work.

2 CHAPTER: THEORITICAL BACKGROUND

In offshore operations there are three main types of accidents that may occur during different activities – dropped objects, helicopter collision, and ship impact. Dropped objects account for approximately 60% of high potential incidents (Sari, et al., 2016). The main aspect of the dropped objects design is to assess and minimize the risk associated with the consequences if such an event occurs and to ensure reliability of the system to achieve safety performance of the equipment during operations and installation. One of the most powerful tool to evaluate the reliability of the system is Failure Mode and Effect Criticality Analysis (FMECA). It can be used during design phase to choose the best of the design alternatives or/and during operations and maintenance planning to avoid failure of the equipment. This section represents a short introduction of the dropped objects and FMECA concept, including criticality matrix, qualification and use of reliability data, the main source of data for the analysis, standarts and regulations used for structural design and reliability analysis, description of the main components and different layouts of an integrated manifold system, functional requirements, installation and service conditions.

2.1 DROPPED OBJECTS

Dropped objects are defined as any object that fall under its own weight from a previously static position or fall due to an applied force from equipment or a moving object (Leong, 2012). Dropped objects can be small objects such as cable trays, tools, tree panel, and gravel infuser with impact energy less than 50kJ, or very large objects such as subsea tree, BOP, tanks, casings and gravel pack screens with impact energy larger than 50 kJ (Drops, 2010). In some cases the energy may reach values greater than 1700kJ, which will lead to catastrophic consequences for the subsea production system. The impact energy of dropped objects is influenced by several factors – the mass and the shape of the object, the water depth and the currents. In terms of the impact energy and the consequences, dropped objects can be classified in three groups (Drops, 2010);

- Dropped objects with impact energy less than 30kJ may cause equipment damage, but is very unlikely to cause severe consequences, such as release of hydrocarbons.

- Dropped objects with impact energy between 30kJ and 50kJ may cause significant damage to the equipment and release of hydrocarbons, but the subsea system integrity would most likely be maintained.
- Dropped objects with impact energy greater than 50kJ has the potential to cause significant damage on the subsea equipment and is likely to cause a release of hydrocarbons.

Based on the offshore activities, dropped objects can be categorized with following operations below:

- Drilling operations;
- Well service operations;
- Lifting operations;
- Vessel operations;
- Other operations.

Small dropped objects may have little or no consequences at all on the equipment. Large dropped object may have very high consequences for the equipment and the environment, because of the greater impact energy involved. Impact caused by dropped objects from nearby platforms or vessels have a high frequency of occurrence and uncertainty of the impact load. The most critical zone for the equipment exposed to falling objects is the lift zone, where lifting operations are carried out. Accidents caused by heavy falling objects may lead to losses of subsea equipment, which can be critical for the production. According to NORSOK U-002 (1998) for multiwell structures, the impact energy larger than 50kJ can be used as an initial design load for dropped objects with diameter 700mm, and 5kJ for objects with diameter 100mm. Dropped objects are considered to be an accidental action, therefore the protective structures are designed for accidental limit state. Main parameters that are determined when analyzing dropped objects are the impact energy, the impact load, and the impact area.

2.2 FMECA

Failure Modes and Effects Analysis (FMEA) is a simple analysis method, which is used to reveal and analyse possible failures modes of all components in the system, to predict the failure effects on the system as a whole and how these failures can be avoided. This method is a systematic analysis of each of the system components. It analyses all possible failure modes and how important they are for the system's performance. If FMEA describe or rank the criticality of the failures, the method is referred to Failure Modes and Effects Criticality

Analysis (FMECA) (Rausand & Høyland, 2004). FMECA is a detailed systematic approach, which provides opportunities to identify and mitigate potential risks and reduces potential failure costs. It identifies where improvements are needed to meet safety and reliability requirements. This can be achieved with detailed assessment of the probability of failure and severity of the consequences. FMECA should be carried out during the design phase and is updated in development and operational phase. An updated FMECA is an important basis for design reviews and inspections (Rausand & Høyland, 2004).

2.2.1 Reliability method

FMECA can be performed using two approaches: ‘top – down’ and ‘bottom – up’ approach. Top – down approach is also called “functional FMECA” and is often used in early design stages. The focus is on top-level system functions rather than on all system components. More accurate method is bottom – up approach. It is also called “detailed FMECA”. It identifies all potential failure modes on the lowest level and goes upwards in the hierarchy analyzing all components or subcomponents of a system. It is performed in two stages. First stage is to split system into subsystems and to identify all failure modes and failure effects for each of the systems. Next step is to analyse all of the components of each stage. If there is no critical failure mode for some of these subsystems, no further analysis is needed. Bottom – up approach is usually used in detailed design and operational and/or maintenance planning.

2.2.2 Reliability data

According to Norsok Z – 016 (1998) the following principles should be applied for selection of reliability data:

- *Data should originate from the same type of equipment.*
- *Data should originate from equipment using similar technology.*
- *Data should if possible originate from identical equipment models.*
- *Data should originate from periods of stable operation, although 1st year start-up problems should be given due consideration.*
- *Data should if possible originate from equipment which has been exposed to comparable operating and maintenance conditions.*
- *The basis for the data used should be sufficiently extensive.*
- *The amount of inventories and failure events used to estimate or predict reliability parameters should be sufficiently large to avoid bias resulting from 'outliers'.*

- *The repair and downtime data should reflect site specific conditions.*
- *The equipment boundary for originating data source and analysis element should match as far as possible. Study assumptions should otherwise be given.*
- *Population data (e.g. operating time, observation period) should be indicated to reflect statistical significance (uncertainty related to estimates and predictions) and "technology window".*
- *Data sources shall be quoted.*

The establishment of reliability data should be performed with attention to original source data, interpretation of available statistics and estimation methods. To meet the requirements above, OREDA database can be used to provide a relevant basis for the analysis. OREDA is a project sponsored by several companies in co-operation with the Norwegian Petroleum Directorate, collecting reliability data for safety equipment. The main objective of this project is to improve safety and provide cost effectiveness in design and operation of oil and gas exploration and production facilities (SINTEF, 2009).

OREDA contains information about topside and subsea equipment, but some onshore equipment is also included. For each subsea equipment unit, the following information is presented (SINTEF, 2009):

- *A drawing illustrating the boundary of the equipment unit, i.e., a specification of subunits and components that are part of the equipment unit;*
- *A listing of all components;*
- *The observed number of failures for each component;*
- *The aggregated observed time in service for the equipment unit, classified as calendar time;*
- *An estimate of the failure rate for each component with associated uncertainty limits;*
- *A repair time estimate, i.e., the elapsed time in number of hours required repairing the failure and restoring the function. This time is the active repair time, i.e. the time when actual repair work was done;*
- *Supportive information, e.g., number of items and installations;*
- *A cross-tabulation of component versus failure mode, of subunit versus failure mode, of equipment unit versus failure mode and of failure descriptor/-cause versus failure mode.*

Different components are classified in "Equipment classes", e.g. pumps, valves, manifolds, Christmas trees etc. Each equipment class is defined by a boundary drawing, which comprises

all sub-units and components belonging to this equipment class. The items in one class are classified as “Equipment unit”. Each equipment unit is subdivided into two lower levels: “sub-unit” and “maintainable item”. Each failure is linked to the relevant component accompanied with a corrective measure.

Subsea part is organized in four levels (SINTEF, 2009):

- **Field/Installation:** *This is an identifier for the subsea field and its installation(s). For each field several installations may be included;*
- **Equipment unit:** *An equipment unit on the highest equipment level used in OREDA which typically includes a unit with one main function, e.g. X-mas tree, control system, etc.;*
- **Sub-unit:** *An equipment unit is subdivided in several subunits, each with function(s) required for the equipment unit to perform its main function. Typical subunits are e.g. umbilical, HPU etc. The subunits may be redundant, e.g. two independent HPUs;*
- **Component:** *These are subsets of each subunit and will typically consist of the lowest level items that are being repaired or replaced as a whole (e.g. valve, sensor etc.).*

Information related to human errors is included in the failure rate estimates. Failures included in the failure data are collected from the maintenance records.

2.2.3 Failure modeling

The main purpose of reliability analysis and shown in OREDA 2002 is to present average failure rate estimates (SINTEF, 2009). A **failure rate** is a function of the time, the age of an item. According to NORSOK Z – 016 (1998) a failure is “*termination of an ability an item have to perform a required function*”. It represents the probability that an item that has survived up to time t , will fail during the next unit of time. The failure rate is also called “hazard rate” or “force of mortality”.

The failure rate is defined mathematically as (Rausand & Høyland, 2004):

$$z(t) \cdot \Delta t \approx \Pr(t < T \leq t + \Delta t | T > t)$$

where: $z(t)$ is a failure rate function;

T – a time to failure;

t – the time the item is still functioning.

The failure rate $z(t)$ can be presented by a “bathtub” curve (Figure 1), which is a realistic model for mechanical equipment. Usually it is high during the initial phase due to undiscoverable defects in the items, called “infant mortality”. They show up when the item is activated. After the infant mortality period, the failure rate stabilizes at some level where it remains for a certain amount of time and after that it starts increasing and begin to wear out.

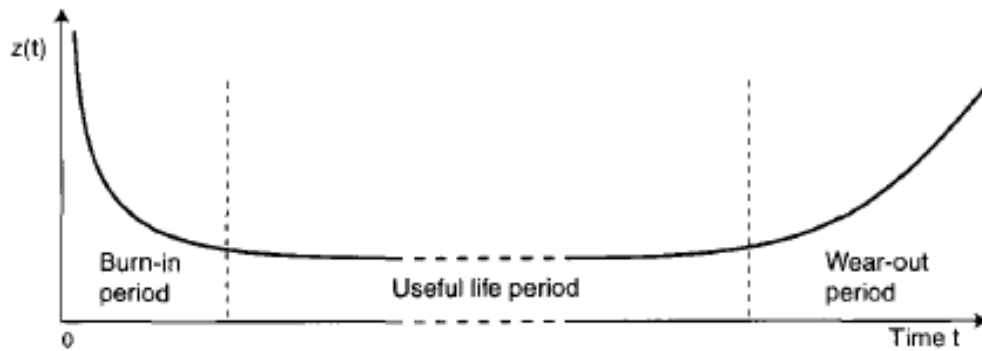

Figure 1: The bathtub curve (Rausand & Høyland, 2004)

Table 1: Failure rate classification

No	Level	MTBF	Description
1	Very likely	Once per 1000 years or more seldom	There is an extremely remote chance that the event might occur, but it probably never will.
2	Remote	Once per 100 years	Not expected, but a slight possibility it may occur at some time.
3	Occasional	Once per 10 years	The event may occur at some time.
4	Probable	Once per year	There is a possibility the event to occur as there is a history of occurrence within industry.
5	Frequent	Once per month or more often	The event is expected to occur as there is a history of regular occurrence within industry.

Lifetime of an item is divided into three periods: burn – in period, useful life period and wear out period. The burn – in problems may be caused by quality problems or installation problems. They can be avoided by quality testing prior to installation. Installation problems are not included in OREDA database. The collection of data for subsea equipment starts with “useful life period”, also called “chance failure period”, when the equipment is already installed. Many of the items in OREDA are subject to maintenance and replacement interventions and they are often replaced before the wear out period, so the failure events in

OREDA database come from the useful life phase, where the failure rate is close to constant. Therefore all the failure rates estimation in the book are assumed to be constants ($\lambda(t)=\lambda$) and independent of time (SINTEF, 2009). Based on this assumption, an item is considered to be “as good as new” as long as it’s functioning.

In many cases it is more suitable to classify the failure rate in rather broad classes (Rausand & Høyland, 2004). An example of such a classification is presented in Table 1, based on GE Oil & Gas (Stendebakken, 2014).

Severity of the failure mode represents the worst potential consequence of the failure. It is determined by the degree of injury, property damage, or system damage that may occur (Rausand & Høyland, 2004). The following ranking categories are often used (Table 2):

Table 2: Severity classification

No	Level	Description
1	Catastrophic	Any failure that could result in deaths or injuries or prevent performance of the intended mission.
2	Critical	Any failure that will degrade the system beyond acceptable limits and create a safety hazard (cause death or injury if corrective action is not immediately taken).
3	Major	Any failure that will degrade the system beyond acceptable limits but can be adequately counteracted or controlled by alternate means.
4	Minor	Any failure that does not degrade the overall performance beyond acceptable limits – one of the nuisance variety.

Table 3: Severity classification

No	Level	Description
1	Catastrophic	Any failure that could result in an irreparable damage of the equipment, or loss of containment and production time, or prevent performance of the intended mission.
2	Critical	Any failure that will degrade the system and will affect the production beyond acceptable limits and create a safety hazard (causes damage of the equipment or the production will stop if corrective action is not immediately taken).
3	Major	Any failure that will degrade the system and will affect the production beyond acceptable limits but can be adequately counteracted or controlled by alternate means.
4	Minor	Any failure that does not degrade the overall performance of the equipment and the production beyond acceptable limits – one of the nuisance variety.

The severity categories should be defined such that they are relevant for the practical application. When dropped objects are analyzed using FMECA, the severity categories can be defined according to the consequences they may have of the equipment and the production of hydrocarbons (Table 3).

2.3 RISK MATRIX

A risk matrix, or also called criticality matrix (Table 5), is used to estimate the criticality level of the system and the most critical failure modes and the consequences that the components' failure may have to the production. It is conducted based on data taken from FMECA. The criticality of the each failure mode is plotted in the matrix and presents the associated risk. The risk matrix consists of the failure rate and the severity. The failure rate rows present increasing severity of consequences of hazards and severity columns present increasing likelihood of these consequences (Gudmestad, et al., 2008). By combining these two categories, the ranking of the criticality of the different failure modes is obtained. The position in the matrix indicates the different level of a criticality of the components due to the production. A risk level is assessed in three categories in Table 4 (Gudmestad, et al., 2008). The high level is considered as the most critical failure mode for the components and is indicated by the brown area in the risk matrix. The medium region is also known as ALARP (As Low As Reasonably Practicable). The ALARP principle is based on “reversed burden of proof”, which means that an identified measure should be implemented unless it cannot be documented that there is an unreasonable disparity between disadvantages and benefits (Aven, 2008). In this area the criticality of the components should be treated and assessed, and risk reducing measures or detailed study should be performed. The medium region is in yellow area in the matrix. The low region is considered to be low critical and is indicated in the white area. This is the region with acceptable and insignificant risk, where risk reducing actions are not necessary.

Table 4: Total risk

Identification	Risk level	Evaluated risk	Description
	High	Intolerable	The risk must be reduced, a need for immediate actions.
	Medium	Tolerable (ALARP)	The risk should be reduced.
	Low	Acceptable	Acceptable risk, actions unnecessary.

An example of a risk matrix is shown in Table 5:

Table 5: Example of a risk matrix

FAILURE RATE	SEVERITY			
	Minor	Major	Critical	Catastrophic
Frequent				
Probable				
Occasional				
Remote				
Very unlikely				

When the most concern is safety or functionality of the system components, the topside area of the diagonal in the matrix is considered to be the most important and must be emphasized because the high severity is more critical than the high occurrence.

2.4 SUBSEA SYSTEM DESCRIPTION

Manifolds and templates are main part of the subsea infrastructure. They connect wells to the pipelines and risers and to the receiving floater, platform or onshore facilities. They can be installed as a stand – alone unit (single well) or an integrated system (multiwell).

2.4.1 Main components

Template/manifold system is a configuration where the manifold is integrated in the template. It is a drilled – through structure, which houses several Christmas trees (XMT) on top of it. The manifold is an arrangement of piping, valves, headers, chokes, hubs, subsea modules and control system, which distribute and control the fluid flow. The template provides a base for the manifold and subsea equipment. Typical template/manifold system consists of (Figure 2):

- 1 – Foundation on the seabed
- 2 – Protective structure (template)
- 3 – Manifold
- 4 – Christmas tree

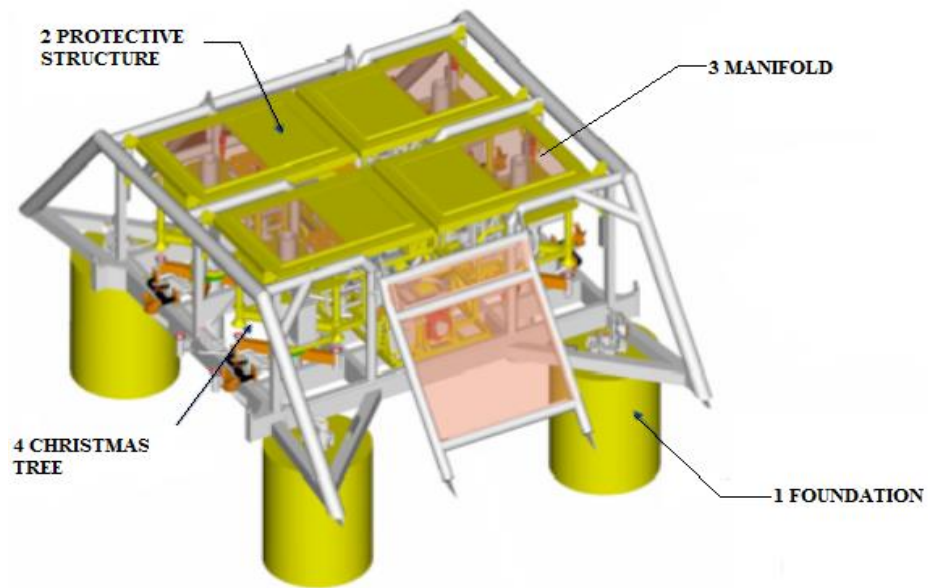

Figure 2: Template/manifold interface (Jansen, 2013)

- **Templates**

The purpose of the template is to provide an installation and protective structure for the subsea components such as manifolds, Christmas trees, drilling and completion equipment. Major components in template required to perform its functions can be seen below (Figure 3, Figure 4):

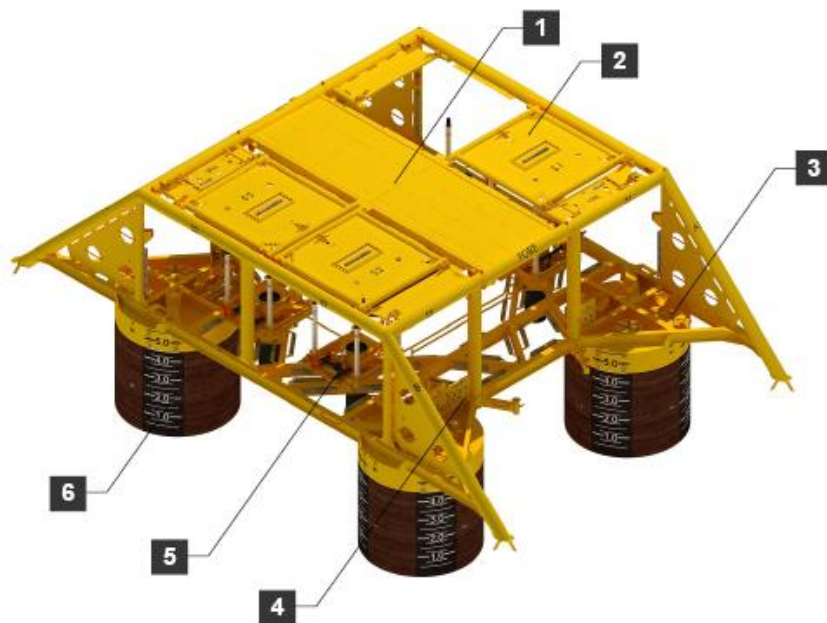

Figure 3: Template (Subsea 1 AS, 2013)

- 1 – Temporary Protection Cover
- 2 – Wellbay Hatches
- 3 – Ventilation Hatches
- 4 – Suction and Grout System
- 5 – Wellbay Inserts incl. Guide Posts
- 6 – Foundation System

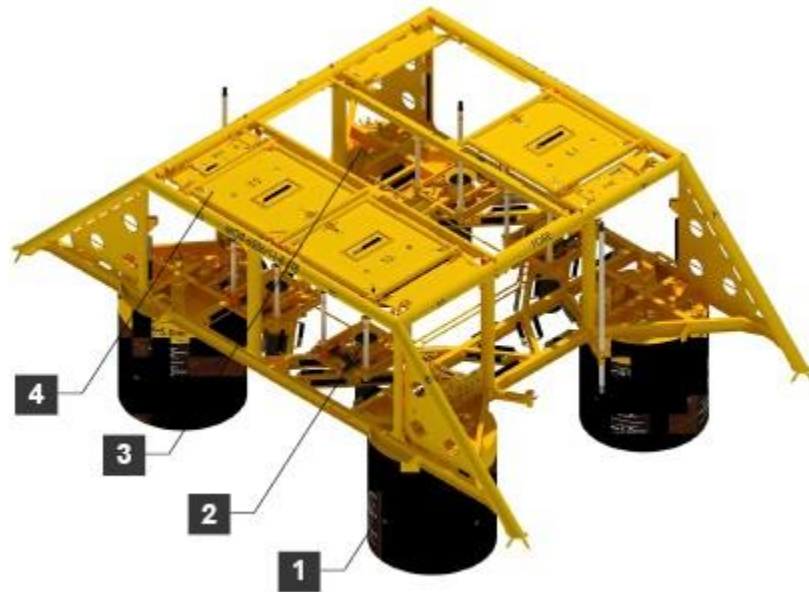

Figure 4: Template interface (Subsea 1 AS, 2013)

- 1 – Seabed
- 2 – Well bay insert/Guide base
- 3 - Manifold
- 4 – Hatches

- **Manifold module**

A manifold is a structural frame where pipelines are entering and leaving the distribution system. It is an arrangement of valves and piping to provide control and monitoring of the fluid flow. A manifold is structurally independent of the wells. The manifold support structure is an interface between the manifold and the foundation. The main functions of the manifold are to provide interface between the production pipelines and wells, to collect the produced fluids, to distribute electrical and hydraulic systems, to distribute injection fluids, to provide

lifting during installation, and to provide support platform for ROV operations. Major components in manifold required to perform its functions include (Figure 5, Figure 6):

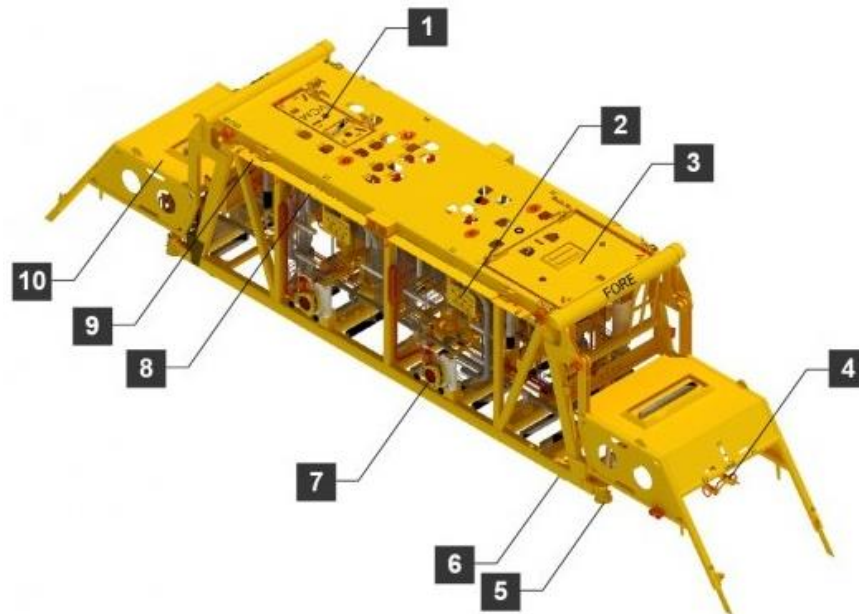

Figure 5: Manifold (Subsea 1 AS, 2013)

- 1 – Vertical Connection Module (VCM) Protection Cover
- 2 – ROV panel
- 3 – HIPPS Protection Cover (if required)
- 4 – Cable Bridges
- 5 – Guide Funnels
- 6 – Damper
- 7 – Horizontal Connection Module
- 8 – Flaps
- 9 – Sling Lock Mechanism
- 10 – Sealine Protector Cover

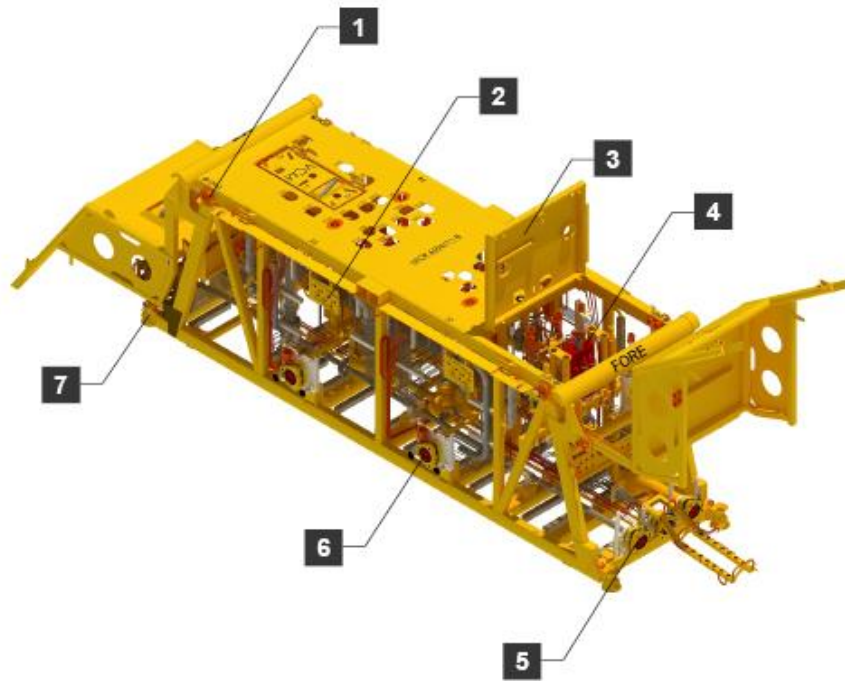

Figure 6: Manifold interface (Subsea 1 AS, 2013)

- 1 – Lifting point
- 2 – ROV interface
- 3 - Hatch
- 4 – Subsea control module
- 5 - Header
- 6 – XMT connection point
- 7 – Guide posts

- **Christmas tree**

A subsea Christmas tree is one of the most essential pieces of the subsea equipment. It is an assembly of valves installed on top of the subsea wellhead to provide a controllable interface between the well and the production facilities. The valves on XMT are used for testing, servicing, regulating, or choking the stream of produced oil, gas, or other liquids. Typical functions of XMT are to direct and regulate the produced flow to the flowline, to monitor the well parameters, such as temperature, pressure, sand detection etc., to stop the flow in a safe manner, and to inject fluids into the well or the flowlines. Main components of the XMT are (Figure 7, Figure 8):

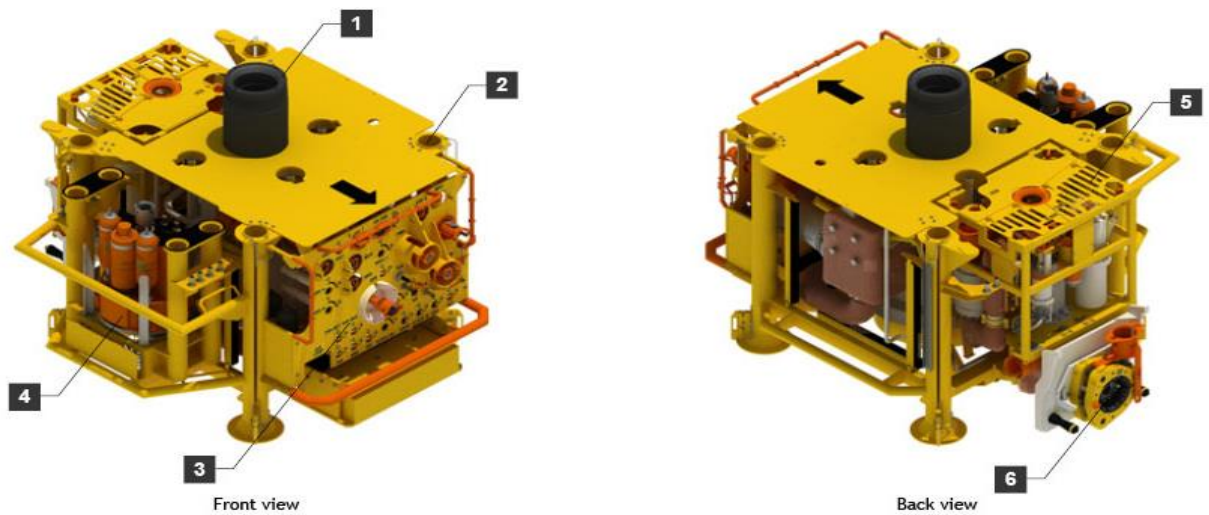

Figure 7: Xmas tree (Subsea 1 AS, 2013)

- 1 – Re – entry hub on top of the main valve block with gate valves and wellhead connector
- 2 – Frame
- 3 – ROV panel
- 4 – Subsea control module
- 5 – Flow control module
- 6 – Manifold connector

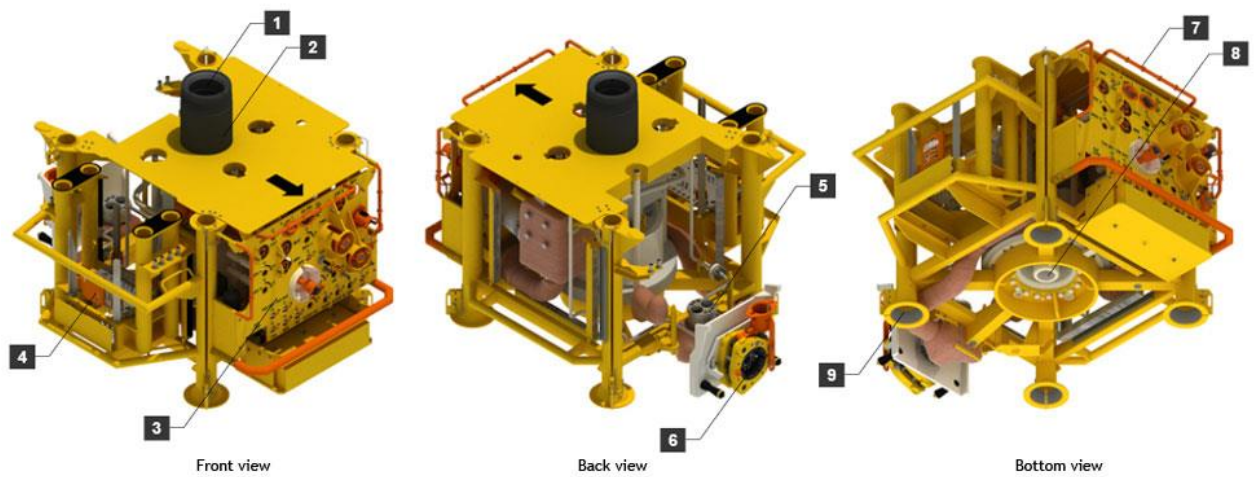

Figure 8: Xmas tree interface (Subsea 1 AS, 2013)

- 1 – High pressure cap
- 2 – To the well via tubing hanger
- 3 – ROV panel
- 4 – To the control system via SCM

- 5 – To the flow control module
- 6 – To the manifold via manifold connector
- 7 – ROV grabber bars
- 8 – To the wellhead via wellhead connector
- 9 – Guide system

There are two main types of XMT: horizontal and vertical. The main difference comes from the location of the valves installed. In case of a vertical XMT, all the valves are in vertical direction, whereas the valves on horizontal XMT are in horizontal direction. Vertical XMT is installed after the well is completed and it allows flexibility of installation and operations. Horizontal XMT is used for wells that need a high number of interventions since it allows simple well interventions and recovery. It is installed onto the wellhead before completion of the well. Configurations of XMT can be different according to the project and field development.

- **Subsea control module**

Subsea control module (SCM) is a part of subsea control system (SCS) and can be located on the XMT, or the manifold. It distributes signals from XMT and downhole sensors to the topside SCS. SCM controls the hydraulic supply and the downhole safety valves, monitors the well pressure and temperature and sand detection sensors. It contains all the control valves, hydraulic pressure monitoring transducers and electronics and enables the XMT to be operated from topside. A subsea control module is shown in Figure 9 and Figure 10:

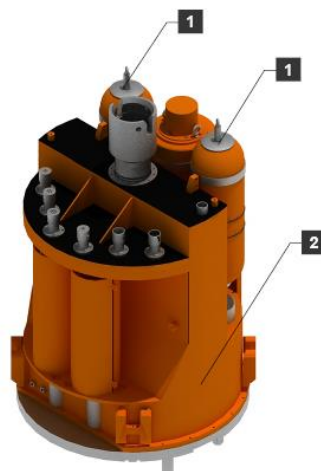

Figure 9: Subsea control module (Subsea 1 AS, 2013)

1 – Accumulators

2 - Housing



Figure 10: Subsea control module (Subsea 1 AS, 2013)

1 – Electrical/Optical jumper receptacles

2 – ROV/Tool interface to lock/unlock from mounting base

- **Flow control module**

The flow control module (FCM) is normally a part of the XMT to regulate and monitor the well flow. It can be installed and retrieved separately from the XMT. The FCM includes all the sensors to monitor the well and injection flow parameters, such as temperature, pressure, and sand. It acts as a mechanical interface between the XMT and the manifold to ensure the connection properties. A flow control module is shown in Figure 11 and Figure 12:

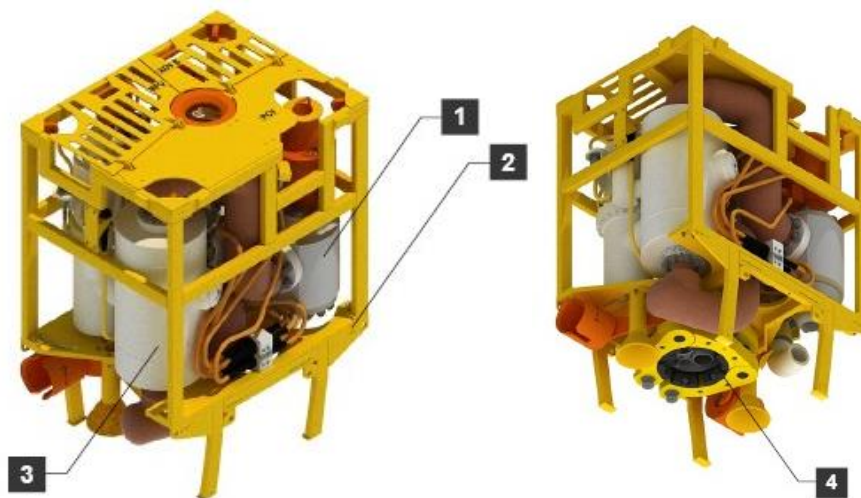

Figure 11: Flow control module (Subsea 1 AS, 2013)

- 1 – Choke
- 2 – Frame
- 3 - Flowmeter
- 4 - Connector



Figure 12: Flow control interface (Subsea 1 AS, 2013)

- 1 – ROV interface
- 2 – Connector for XMT interface
- 3 – Flow control module running tool interface
- 4 – ROV interface
- 5 – ROV interface
- 6 – Junction box for control system interface

- **Pigging system**

Pigging facilities are incorporated in subsea pipeline design. Pigging system consists of pig launcher and pigging pipes that are placed inside the pipe and traverse the pipeline. Pigging system is used in wax management to retrieve the deposition in the pipelines by injecting wax dispersant chemicals. The launcher is made of a short segment of pipe and is two times larger than the main pipe. It consists of blowdown valves, vent valves and pressure gauges on the top and drain valves on the bottom (Figure 13).

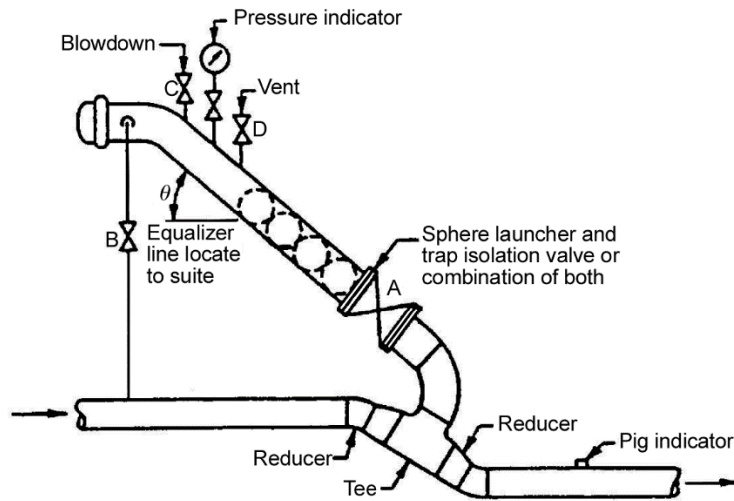

Figure 13: Pigging launcher (Petrowiki, 2015)

- **Remote operated vehicle panel**

Remote operated vehicles (ROV) are required to carry out tasks that divers cannot reach, such as site survey, drilling assistance, installation assistance, operation assistance, inspection, maintenance, and repair. ROV panel is located on the XMT, manifold, or other subsea equipment and it is an ROV interface for operating the subsea valves manually.

- **Subsea valves**

Reliability of the subsea equipment is strongly dependent on subsea valves because they control the flow of the production and injection fluids. They are mounted within the piping system. One of the main design requirements is that all remotely controlled valves should be located within retrievable frames or modules (Bai & Bai, 2012).

There are two main types of valves used in the manifolds: gate valves and ball valves. Usually gate valves are used for liquid pipelines, and ball valves are specified for gas pipelines. Valves are designed according to API 6A and 17D and can be used up to a water depth of 4000m. Figure 14 shows a subsea gate valve, which can provide a thru – conduit, upstream and downstream seal. It can operate with pressure up to 15000psi and water depth up to 4020m (13200 feet).

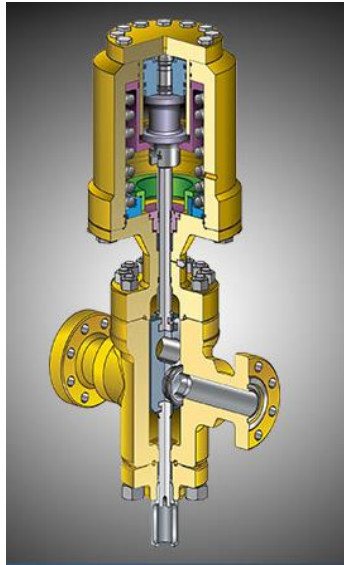

Figure 14: Subsea gate valve (Worldwide Oilfield Machine, 2016)

Figure 15 shows a typical two – way subsea ball valve, which is designed to facilitate operation by an ROV. The valve can be used in a water depth of 3810m (12500 feet) and pressure up to 20000psi. Ball valves can be installed both as isolation valves and as check valves to prevent back flow in the system.

There are three main types of valves located on the XMT: production master valves, production wing valves, and annulus valves. Production master valves (PMVs) provide fully operational during normal production. These valves are high – quality gate valves and must be capable to hold the whole pressure of the well safely, because they represent the second pressure barrier. A production choke is used to control the flow rate and reduce the flow pressure. They are used to completely shut down the production tubing and the annulus.

Annulus valves are used to equalize the pressure between the upper space and lower space of the tubing hanger during normal production.

Crossover valve (XOV) is located in the crossover loop. It is an optional valve that allows communication between the annulus and production tree path when it is opened. It may be used for fluid passage for well kill operations or to overcome obstructions caused by hydrate formation.

Wing valves are used to control the production of hydrocarbons, injection of fluid or gas for reservoir control or annulus bore. In case of emergency, they are used to shut down the flow from the well.

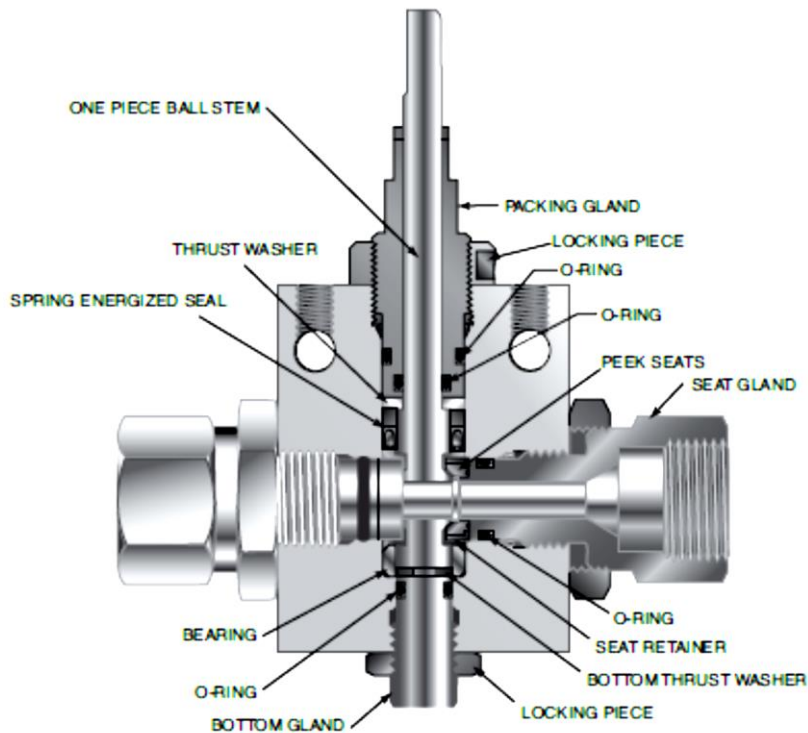

Figure 15: Typical two – way subsea ball valve (Parker-Hannifin Inc., 2016)

- **Flowline connectors**

Flowline connectors are used to connect XMT and manifold to the pipelines and in some cases to provide a mean for disconnecting and removing the XMT or manifold without retrieving the flowline to the surface. There are three main types of connectors: manual, operated by ROV; hydraulic with integrated hydraulics, or mechanical with the hydraulic actuators contained in a separate running tool. A typical flowline connector is shown in Figure 16:



Figure 16: Flowline connector (FMC Technologies, 2006)

- **Piping system**

The piping system is usually dependent on the manufacturers' criteria. Flanged components or welded one can be used. The flow loops may be fabricated using forged fittings or pre-bent pipe sections, or may be formed in a continuous piece of pipe.

2.4.2 Subsea system layouts and design aspects

Subsea wells can be installed individually in clusters as a stand – alone units, or in multiwell/manifold templates. Stand – alone manifold template consists of individual satellite wells connected to the template via jumpers. Jumpers can be flexible or rigid pipes. Each module has its own foundation. The template has a connection point from the manifold to a host facility (Figure 17).

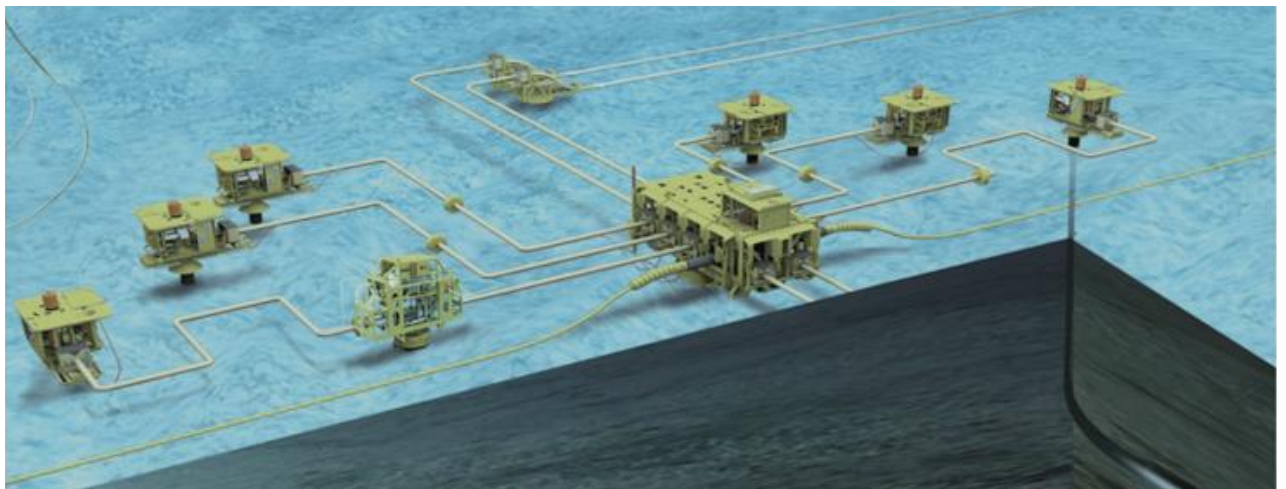

Figure 17: Stand – alone manifold template (cluster) (Jansen, 2013)

Multiwell manifold/template is an integrated template, where multiple wells are drilled and completed through it, and the manifold system is also included. Flowline or production riser connects the template to a host facility (Figure 18).

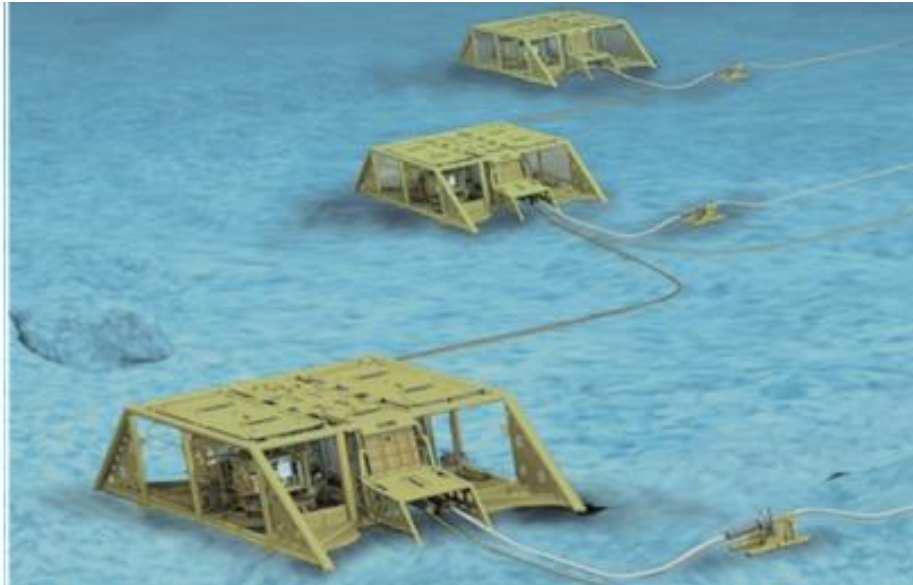

Figure 18: Multiwell manifold/template (Jansen, 2013)

Main design drivers for choice of system configuration are local legislations and cost. In areas where there are no requirements for overtrawlability of the equipment (Gulf of Mexico), typical solution is cluster configuration, where each module has its own foundation on the seabed. This solution is also suitable for large reservoirs where there are a large numbers of subsea module units. From a financial perspective, cluster configuration can be expensive with complex subsea footprint according to the large number of stand – alone structures, umbilicals and jumpers. Installation and drilling is quite complicated due to a remote well location. In other parts of the world, where there is a requirement for overtrawlability of the equipment, e.g. Norwegian Continental Shelf (NCS), typical subsea field development consists of multiwell manifold/templates. All the subsea equipment is installed in one template and protected by one protective structure. This configuration provides easy installation and drilling methods, simple subsea footprint and cost saving alternative.

The template/manifold system should provide a sufficient amount of piping, valves, to control and collect the reservoir fluids and injection fluids such as gas, water, or chemicals in a safe manner (Bai & Bai, 2012). The equipment should be designed to allow pigging and monitoring of the operations. It may also include a distribution system for hydraulic or electrical supplies for the control system. The addition of spare well slots should be considered in the design. Accidental damage loads and a maintenance approach should be taken into account during the initial design. Manifold design and analysis should address the following issues (Bai & Bai, 2012):

- *Steel frame structures and painting design;*
- *Pipework and valve design;*
- *Connection equipment and control equipment;*
- *Flow assurance and hydraulics.*

- **Steel frame structures**

Structural design of template/manifold follows relevant standards for subsea structures. Structural frame should provide support and protection for header piping and control tubing, guidance and alignment of the manifold onto the foundation, sufficient space for the manifold piping and valves, well/flowline jumper interface with access to pipeline end connector running tools, ROV access, pile foundation, and operational interfaces for installation, lifting and handling. It should consist of all anodes necessary for cathodic protection and external drainage and corrosion protection.

- **Piping**

Piping system comprises straight pipes, bends, tees, and reducers. It should be designed to satisfy the requirements for internal pressure, thermal loads, hydrostatic collapse, and external operational loads and fabricated requirements. Stress analysis may be performed using a finite element software package. The following issues should be considered: internal pressure, hydro testing, thermal loads, jumper loads, environmental loads, external and internal corrosion, piping supports for anticipating loading, deflections and vibrations.

- **Pigging loop**

The manifold pigging loop provides round – trip pigging of the flowlines from the production platform and allows passage of pigs through the main headers. It is mounted on the inlet hubs of the production manifold. Pigging loop design includes determination of piping size, bend radius, valve types, pig launcher/receiver, and pig location determination. The pigging loop should provide facilities for chemical injection through two parallel hydraulically operated gate valves with integrated check valves. The full – bore gate valve should allow a pig to pass without any restrictions and should be hydraulically operated. The pigging loop should be made of the same material and size as the production manifold pipeline header piping. Bend radius is five times the nominal pipe diameter.

- **Control system**

The production control system operates valves and chokes on subsea trees and manifold/templates. The hoses materials should be tested in stressed conditions for actual working pressure. The insulation materials for electric cables should be qualified for all relevant fluids. The materials for electrical termination should be of similar type to ensure good bonding between different layers. The materials for outer protection and distribution system should have qualified compatibility with respect to dielectric fluid/pressure – compensation fluid and seawater.

- **Flow assurance**

Flow assurance maintenance should be carried out for subsea equipment exposed to harsh environmental conditions and stagnant fluids under normal or transient flow conditions. The potential risk of hydrate formation should be considered in wellbores, subsea pipelines, and subsea equipment during drilling and production operations. The hydrate management philosophy for subsea systems should ensure that no continuous inhibition of the subsea system is required in flowing conditions or no part of the fluid system is allowed to enter the hydrate formation domain during flowing and shutdown and startup operations. Also, the cold production fluid released by the well shall be inhibited at the wellhead until the production temperature reaches a temperature high enough to ensure sufficient cooldown time if another shutdown occurs (Bai & Bai, 2012).

2.4.3 Functional requirements

Subsea template/manifolds are installed on the seabed within an array of wells. It is a system structurally independent of the wells. Subsea manifold system is designed to meet the specific functions such as control and testing the flow, injection of gas into the riser base, gas lift injection into the tubing, water injection and well operation control. The main functional requirements can be summarized as follows (Bai & Bai, 2012):

- *Provide an interface between the production pipeline and well.*
- *Collect produced fluids from individual subsea wells.*
- *Distribute production fluids.*
- *Inject gas and chemicals into the well.*
- *Control fluids.*
- *Distribute electrical and hydraulic systems.*

- *Support manifold wing hubs, pipeline hubs, and umbilical hubs.*
- *Support and protect all pipe work and valves.*
- *Provide lifting points for the manifold system during installation and retrieval.*
- *Provide sea – fastening interfaces.*

Each template/manifold is designed for specific field conditions. The configuration, weight and size depend on the specific design requirements.

2.4.4 Installation of subsea multiwell template/manifold

In deep water fields, the risk associated with installation and the contribution of installation activities to project costs are higher than the shallow water developments. The metocean condition of deep water is a key factor for the installation of subsea structures (Bai & Bai, 2012). In some regions (Brazil) high currents are the dominating factor, but in other areas (GOM) the swell motion influences the vessel motion resonance. A subsea development may have more than 30 wells, with large number of individual items and heavy manifolds, which required a long installation program and can be a huge challenge. The capability of the subsea installation system is strongly dependent of the components limitations (Bai & Bai, 2012):

- *Lifting and lowering system, which includes vessels, lift time, and overboarding/ lift line deployment system;*
- *Load control and positioning system, including motion compensation system, buoyancy hook/payload control/positioning, and communications.*

The installation of subsea structures should be planned carefully and coordinate with workboats, a crane barge or floating drilling vessel. The choice of installation vessel depends on vessel availability, crane capacity and existing mooring equipment. The installation method and equipment should provide saved and reliable operation, and should satisfy the following issues (Bai & Bai, 2012):

- *Be video recorded during installation operations.*
- *Use installation tools with a fail – safe design.*
- *Allow flushing of hydraulic circuits subsequent to connection of interfaces.*
- *Not be dependent on unique vessels.*
- *Have position indicators on all interface connections.*
- *Be installable utilizing a minimum number of installation vessels.*
- *Require installation within a defined practical weather window that is consistent with the specific type of installation equipment and vessel to be used.*

- *Require a minimum number of installation tools.*
- *Facilitate fully reversible sequential installation techniques/operations.*

The installation analysis is usually performed during the final phase of the project to ensure that the subsea manifold structure can handle the installation, leveling, and lowering forces using proper safety factor. The installation procedure normally includes the following steps (Bai & Bai, 2012):

- *Lifting from the deck of the crane vessel.*
- *Lowering through the splash zone.*
- *Load from the manifold is transferred from the crane to A&R wire due to water depth.*
- *Lowering analysis at critical resonance depth.*
- *Landing on the seabed when control velocity and heave amplitude of the manifold.*

Usually software is used to perform installation analysis and dynamic simulations, e. g. Orcaflex.

2.5 STANDARDS AND REGULATIONS

Law and regulations specify the industrial and design requirements of every project. Standards are developed to ensure adequate safety, value adding and cost effectiveness for petroleum industry developments and operations (Norsok Standards, 2015). International (ISO) and European (DNV) Standards form the activities in the industry. The climate conditions and the safety frame work, require specific Norwegian standards or additions developed due to the specific needs. The code requirements vary with customer preference and local legislation. The standards used in this thesis for template/manifold design of dropped objects are:

- NORSEK U – 002 Subsea structures and piping design (1998);
- NORSEK N – 004 Design of steel structures (2004).

Standards used for reliability design and structure integrity are:

- NORSEK Z – 008 Criticality analysis for maintenance purposes (2001);
- NORSEK Z – 016 Regularity Management and Reliability Technology (1998);

These standards are used for FMECA and Dropped objects calculations and for understanding of the functions and requirements of manifold/template system.

3 CHAPTER: METHODOLOGY

To perform reliability analysis procedure, it is important to understand the purpose of the system, the functions of each component, what causes the failures, how they can be detected, and what can be done to avoid failures. A typical integrated template/manifold is chosen and some necessary assumptions are made for the purpose of the analysis. The construction of FMECA is systematically created in a sheet containing parameters that can vary from one sheet to another, but in general the parameters include a name of the component, function, operational mode, failure mode, failure mechanism, detection of failure, local effect, global effect, corrective measures and failure rate (frequency), severity (failure effect ranking) (Rausand & Høyland, 2004). Last step of the analysis is to create a risk matrix based on the FMECA sheet and estimate the criticality of the system components.

3.1 ASSUMPTIONS

Analysis of dropped objects' effect on the subsea production system is based on some assumptions and parameters as follows:

- A typical multiwell template/manifold is chosen that consists of:
 - 6 wells;
 - 6 vertical XMTs;
 - a protection cover;
 - a manifolds module;
 - a pigging module with a pig launcher.
- Only the system components that can be exposed and affected by falling objects are described and analyzed in Table 9, APPENDIX B.
- The FMECA is conducted only due to dropped objects' impact and the consequences this impact will have on the production of hydrocarbons.
- The analysis is performed based on “bottom – up” approach.
- The analysis in FMECA sheet is performed for one well with the corresponding XMT.
- If one of XMT fails, the rest cannot continue and the system will stop producing.
- Each component has one failure mechanism caused by impact load due to dropped object.

- One component may have more than one failure modes, each of these failure modes may leads to each of the local effect listed for the corresponding component.
- One component may have more than one failure modes, each of these failure modes may leads to each of the global effect listed for the corresponding component.
- According to the previous two assumptions, the referent number of a component matches the risk index of the corresponding failure mode(s);
- Only operational risk is considered since the purpose of the analysis is focused on the criticality of the system due to the production.

It is important to be noted that not all of the component of the multiwell template/manifold system are analyzed. Some of them are protected by different structure elements and it is considered that even if the system is hit by a falling object, they cannot be damaged. Another important consideration is the protective level of each component. An integrated manifold is protected by a template against third party activities, such as dropped objects. It is assumed that only if the template structure fails then the manifold, pigging module and XMT and their components will be exposed to free falling objects, which will reflect in the failure rate and the component criticality.

3.2 ANALYSIS PROCEDURE

A detailed FMECA procedure includes various entries in a worksheet and in a risk matrix.

The analysis is performed in a following sequence:

1. Create a system breakdown structure to identify all system components for analysis to identify system functions.
2. List all functions of the component.
3. List the operational modes of the component.
4. List all potential failure modes associated with every component or function.
5. For each of the failure modes identified, identify failure mechanisms or other causes that contribute to the failure.
6. List the different possibilities for detection of the identified failure modes to identify possible hidden failures.
7. Identify the local effects each failure mode may have on the other components if only this failure mode occurs.
8. Identify the global effects each failure mode may have on the system as a whole.

9. For each failure mode qualitatively determine the failure rate.
10. For each failure mode qualitatively determine the severity if it should occur.
11. List measures to correct the failure or mitigate serious consequences and/or measures to lower the likelihood of occurrence.
12. Give all failure modes a risk index.
13. Perform a risk matrix.

The various parameters in the FMECA sheet can be best illustrated by going through column by column (Rausand & Høyland, 2004):

- Component The name of an item.
- Function The description of an item function, its working task in the system.
- Operational mode The condition under which the item operates.
- Failure mode The possible way the component can fail to perform its function. Failure mode can be observed from “outside”. For each component’s function and operational mode, all the failure modes are identified and recorded.
- Failure mechanism Basic physical process that can be lead to failure. The possible failure mechanisms that may produce the identified modes are recorded in this column. Other failure causes are also recorded.
- Detection of failure The various possibilities for detection of the identified failure modes are recorded.
- Local effect Effects on other units in the same subsystem are recorded.
- Global effect All the main effects of the identified failure mode on the function of the system are recorded. The resulting operational status of the system after the failure is also recorded; whether the system is functioning or not.
- Failure rate An assigned probability for the specific failure mode and consequence. Failure rates for each component are recorded according to Table 1.
- Severity The failure is ranked according to its effect with respect to reliability and safety. Severity of a failure mode is the worst potential consequence of the failure. Severity is identified

according to Table 3.

- Risk reducing measure Possible actions to correct the failure and restore the function or prevent serious consequences are recorded.

Defining the system elements gives clarity of the purpose of the system and the operational details. A system breakdown structure is a representation of an interrelationship and interdependences of the functional components, which are involved in the operations. It also helps to analyze the failure modes and their effects. According to NORSOK Z-008 (2001), a failure is *the termination of the ability of an item to perform a required function*. Further, a failure mode can be described as effect by which a failure is observed on the failed item. It can be identified by studying the output of the function. Failure modes depend on the specific component, system and environment. Failure mechanism can be described as a physical, chemical or other process which lead or have led to failure. Local effect is the specific effect and the result from the failure mode of the component. Global effect influences other failure modes. Risk reducing measures are considered in terms of dropped objects accidents that may occur.

4 CHAPTER: RESULTS

The main purpose of this thesis is an evaluation of the most critical components of the multiwell template/manifold system with respect to the production if the system is exposed to falling free objects during different operational conditions. An important part of the reliability analysis is to determine and estimate the possible consequences and the effect of the failures. All possible failure modes are considered in the analysis since accidents caused by falling objects can occur during various offshore activities, such as lifting, drilling, vessel operations and many others. The consequences of the failure modes are estimated based on the possible outcome of the failure. It is considered the worst possible outcome of consequences for the production if a potential failure occurs. All of the failure mechanisms are caused by the impact load due to dropped objects; an exception is only the failure mechanism of cable bridges, which is caused by fatigue damage as a result of continuously action of falling objects. That may results in damage of the cables and loss of electricity supply of the system.

FMECA is conducted to identify the possible failure modes and the effect they may have on the reliability of a multiwell manifold/template if it is exposed to dropped objects and what the consequences will be to the oil and gas production. The analysis performed is based on the description of the subsea production system in Chapter 2 and assumptions made in Chapter 3. All the components of the system exposed to dropped objects are identified according to the breakdown structure of the system and the system's failure modes are analyzed using FMECA method and plotted in the criticality matrix. The analysis made is based on the results obtained from the FMECA sheet and the risk matrix.

A breakdown structure is used in the detailed FMECA to identify all the components of the system. The multiwell template/manifold system is divided into four main equipment subunits according to OREDA Offshore Reliability Data Handbook:

- Template (protective structure);
- Manifold module;
- Pigging module;
- Christmas tree.

Each of these four subunits consist of different components, which can be seen in the breakdown structure of the system shown in Figure 23, APPENDIX A. The system includes six XMTs, but according to the assumptions made in Chapter 3, only one XMT is considered to be analyzed, for as much as one out of six XMTs fails, the system will stop producing. Therefore, the breakdown structure includes one XMT as a subunit with the corresponding components.

FMECA is performed using “bottom – up” approach or also called “detailed FMECA”. The analysis is conducted to identify the impact of dropped objects on the components and the influence this impact may have on the ability of the multiwell template/manifold system to produce hydrocarbons. The system is broken down into components taken from the breakdown structure, which have a significant importance for the system performance. Only one well with the corresponding XMT is analyzed in FMECA sheet according to the assumptions made in Chapter 3. Parameters listed in Chapter 3, section *ANALYSIS PROCEDURE* are used in FMECA sheet. For each of the components, all possible failures are described and evaluated using a failure rate and a severity ranking in terms of the worst potential consequences they may have to the system performance and the production. The categories classified in Chapter 2, section *Failure modeling*, Table 1 and Table 3 are used.

Table 6: Risk matrix (Operational risk)

FAILURE RATE	SEVERITY			
	Minor	Major	Critical	Catastrophic
Frequent				
Probable				1, 3, 6
Occasional	20, 21, 54	18, 19, 39, 40, 48		2, 4, 5, 7, 11, 12, 15, 31, 55
Remote	25	17, 38, 46, 49, 50		8, 9, 10, 13, 14, 16, 32, 33, 34, 56
Very unlikely	24	35, 44, 45	22, 26, 27, 28, 29, 30, 41, 42, 43	23, 36, 37, 47, 51, 52, 53, 57, 58, 59, 60

In the risk matrix all system components are presented by their referent numbers from the FMECA sheet (Table 9, APPENDIX B), which corresponds to the failure mode risk index for the relevant component. Failure modes are plotted in the matrix (Table 6) according to their failure rate and severity ranking estimated in the analysis. Criticality of the components is ranked according to Table 4 in Chapter 2. A risk matrix is conducted in terms of the operational risk, since a point of interest is only the consequences due the production of hydrocarbons.

Table 7: Summary of the components' risk level

Identification	Risk level	Subunit	Ref. No	Components
	High	Template (protective structure)	1	Top plate
			2	Side plate
			3	Horizontal beam
			4	Column
			5	Welds
			6	Wellbay hatches
		Manifold module	7	Top plate
			11	HIPPS protection cover
			12	VCM Protection cover
		Pigging module	15	Sealine PC top plate
31	Top plate			
XMT	55	Protection cover		
	Medium	Manifold module	8	Horizontal beam
			9	Column
			10	Welds
			13	Vertical connection module
			14	Horizontal connection module
			16	Sealine PC side plate
			18	ROV frame
			19	ROV grabber bars
			23	Flowline connector
			Pigging module	32
		33		Column
		34		Welds
		36		Pig launcher
		37		Piping (hard pipe)
		XMT	39	ROV frame
			40	ROV grabber bars
			47	SCM jumpers
			48	FCM frame top plate
			51	XOFL
			52	PFL
53	Piping (hard pipe)			

			56	Re – entry hub
			57	Manifold connector
			58	SCM connector
			59	FCM connector
			60	Flowline connector
	Low	Manifold module	17	ROV panel
			20	Lifting points
			21	Guide posts
			22	Cable bridges
			24	Flap
			25	Sling lock mechanism
			26	Piping (hard pipe)
			27	Control valve
			28	Check valve
			29	Utility isolation valve
		30	Process isolation valve	
		Pigging module	35	Flowline connector
			38	ROV panel
		XMT	41	PVB
			42	WVB
			43	AVB
			44	SCM housing
			45	SCM accumulators
			46	SCM ROV interface
			49	FCM frame column
			50	FCM frame beam
		54	Tree cap	

According to the results obtained in *Table 6: Risk matrix*, major part of the components and their associated failure modes are estimated with medium frequency of occurrence and severity – 26 out of 60 failure modes are in the yellow area and required further evaluation and reducing the risk to acceptable limit. Only 12 of the failure modes are in the high risk level area and required risk reducing measures to be performed. 22 out of 60 failure modes are in the white area, where risk reducing actions are not necessary and the risk is insignificant (Table 8).

Table 8: Summary of the risk level evaluation

Identification	Risk level	Evaluated risk	Number of components
	High	Intolerable	12
	Medium	Tolerable (ALARP)	26
	Low	Acceptable	22

It can be seen from Figure 19 that the failure modes, which are not critical for the system, are 37% of all failure modes and are estimated with an acceptable risk level. 43% are in the medium region and required further evaluation and risk reducing measures, where the risk should be reduced to a level that is As Low As Reasonably Practicable, and 20% of the failure modes are estimated with a high risk level, which requires immediate actions to be taken to reduce the risk to an acceptable level.

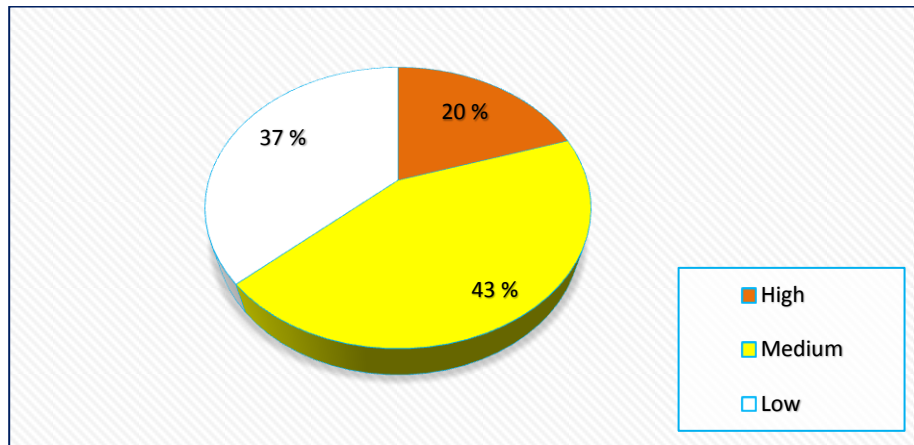

Figure 19: Summary of the risk level distribution

The results obtained from the risk matrix show that 12 components are in *the high risk level area* (Table 7). Most of them (six) are elements of template protective structure, four – of manifold module, one – of pigging module and one is a part of the XMT (Figure 20). All the components of the template protective structure are found in this area. A top plate, a horizontal beam and wellbay hatches are the components with the highest frequency of failure and severity of occurrence. The probability of each of these elements to be exposed to dropped objects' impact is very high – at least once per year. The consequences on operations are considered to be with catastrophic for the production. They are the main and most important components of the protective structure; if they fail, that will lead to damage on the rest of the main subunits (XMT, manifold, pigging module) and inability of the system to produce.

The rest of the components (with ref. number 7, 11, 12, 15, 31 and 55) in the brown region are with the same severity, but less frequency of failure – at least once per 10 years. It can be seen that all of these components are protective structural elements, which are part of the main protective structures or support these structures. A failure of any of them will lead to damages

on the XMT, manifold and pigging module, loss of structure integrity, which will cause to loss of containment and will prevent further production.

A template protective structure and protection elements of manifold, pigging and XMT are very difficult to repair and/or to retrieve. The repair and retrievable time is a long and a costly process. If failure of some of these components occurs, repair cannot be initiated immediately. That will result in a loss of production time, which will lead to financial losses.

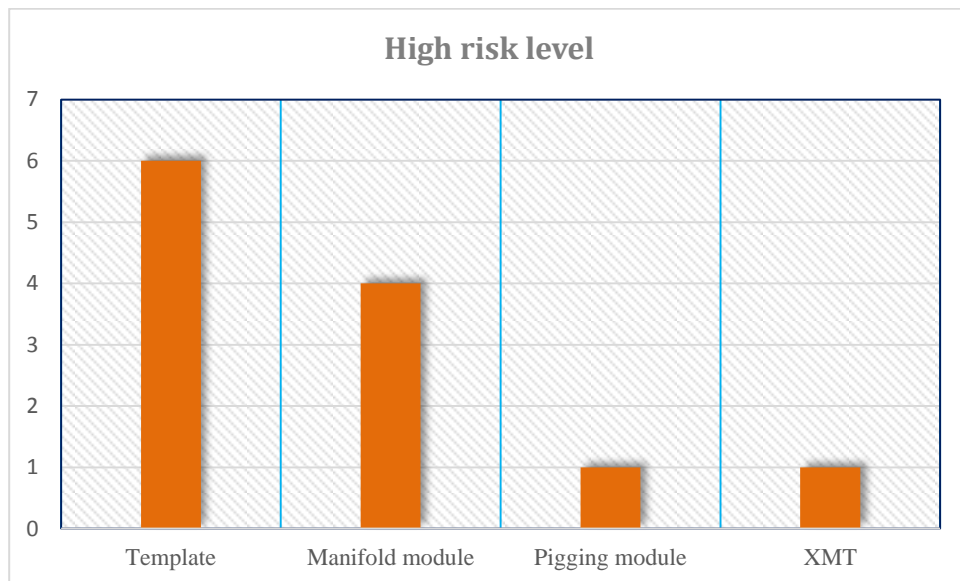

Figure 20: Distribution of the failure modes in high risk level region

A medium risk level area contains 26 items (Table 7) including components of a XMT, a manifold and a pigging module. Nine of these components are situated in the manifold module, five – in pigging module, and twelve – in the XMT (Figure 21). Two of the manifold module components (with ref. number 18 and 19) and three of the XMT (with ref. number 39, 40, 48) are estimated with moderate probability of occurrence – at least once per 10 years, and with consequences for the production, which will not result in a production loss and/or a downtime. Some of these items, such as ROV frames and grabbers situated on the manifold and the XMT, are supporting element for ROV activities during operations and installation. A failure of the ROV frame and/or grabbers will lead to damage on the ROV panel and hence inability to operate the main valves remotely, which will result in difficulties in some of the subsea activities during installations and operations. That will increase the time needed for installation of the equipment and delays in offshore operations executed after installation, such as drilling and well service activities. A FCM top plate is a part of the FCM protective

structure. If the top plate fail that will lead to damage of the FCM and inability to regulate the wellflow, thus the FCM is installed separately from the XMT. If failure occurs, repair should be initiated as soon as possible.

Ten of the components in the yellow region (with ref. number 8, 9, 10, 13, 14, 16, 32, 33, 34, 56) are with very high severity, but less frequency, thus situated in the lower right area in the risk matrix. Nine of them are a part of a protective structure or support the protection of the manifold and the pigging module. The re – entry hub is situated on the XMT. It connects the XMT to the wellhead and is responsible for the flow control. These ten elements are classified with severe consequences for the operations. A failure of some of them will lead to damage of the major components critical for the production, such as manifold, pigging module and XMT, which, as mention above, are difficult to repair. Since the manifold, pigging and XMT are protected by the template, the frequency of failure is estimated to be low. It is considered that these components will fail, if the template protective structure fails due to dropped object impact and it is not capable to protect the equipment.

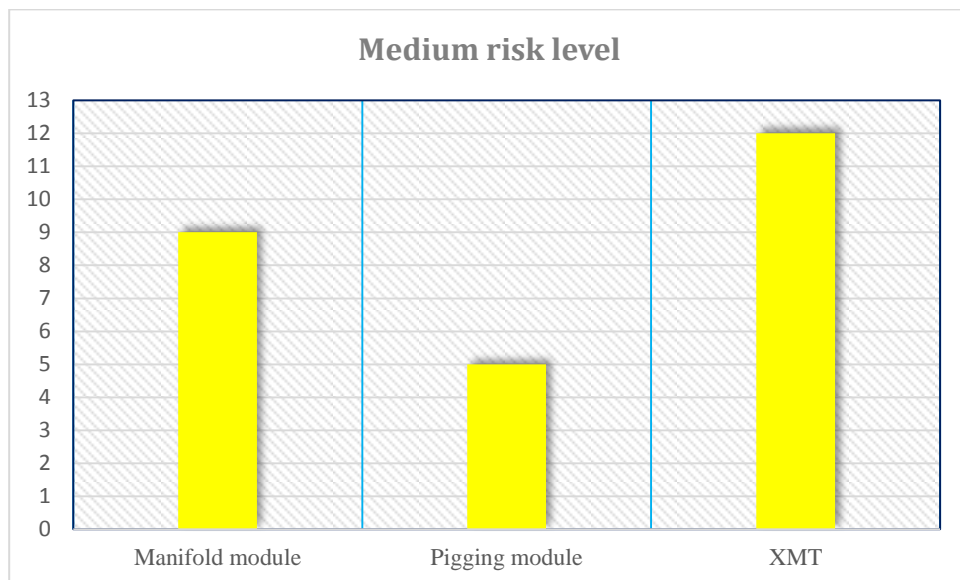

Figure 21: Distribution of the failure modes in medium risk level region

Eleven elements are plotted in the lowest right corner of the risk matrix (ref. number 23, 36, 37, 47, 51, 52, 53, 57, 58, 59, 60) – one is situated on the manifold, two on the pigging module, and the rest (eight) on the XMT. They have high severity of occurrence, but very low probability of failure – once per 1000 years. If one of these elements fails, the consequences will be severe for the production. They connect different elements of the system and conduit

the flow. Any failure will result in loss of containment, external leakage, which will lead to stopping of the production, production time loss, thus financial losses. All components in the medium area required further evaluation and reducing the risk to an acceptable level.

There are 22 components in *the low risk level area* (Table 7). Half of these components (11) are situated on the manifold module, one on the pigging module, and 10 are part of the XMT (Figure 22). This is an area with acceptable and insignificant risk, where risk reducing measures are not necessary. Components' failures are considered to be not critical for the production with very low severity of occurrence and very low frequency of failure. Some of the components are valves situated in separately retrievable modules with very low probability of failure, but with high severity of occurrence classified as "critical". If failure occurs in some of the main valves (ABV), repair should be initiated immediately. Components with lowest probability of failure and severity are the flap, sling lock mechanism, flowline connector of the pigging module, SCM housing and SCM accumulators.

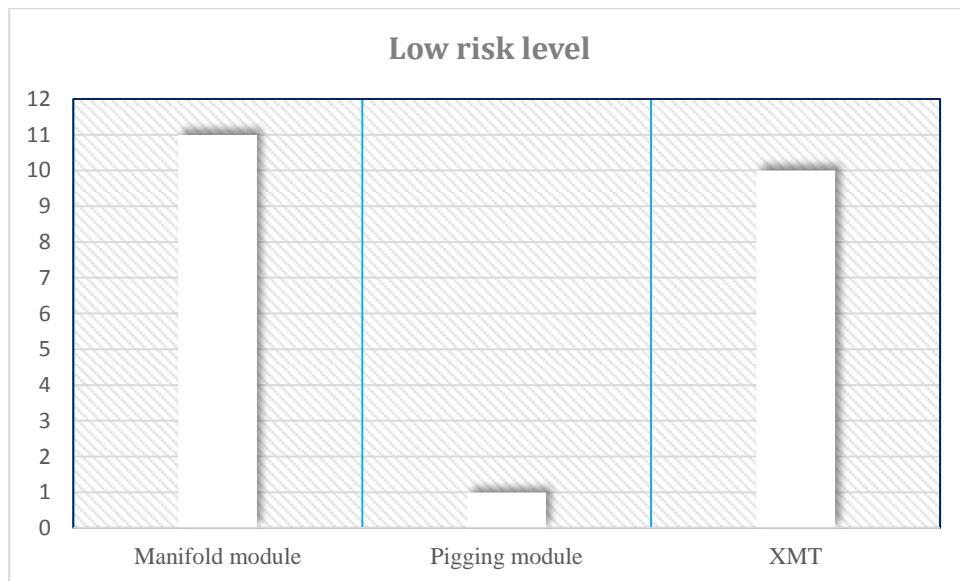

Figure 22: Distribution of the failure modes in low risk level region

5 CHAPTER: DISCUSSIONS

The results obtained from the reliability analysis show that the most critical components of the system are top plate, horizontal beam and wellbay hatches situated on the template protective structure. This is a result based on a general case analyzed with some assumptions considered. There are many factors, which can be also supplemented in addition to the reliability and dropped objects analysis with significant importance and which can be used to assess criticality of the subsea production system.

The main functions of the template/manifold are to provide an interface between the production pipeline and well, collect, distribute and control produced fluids from the subsea wells, support and protect the manifold, XMTs, pipelines, umbilicals and valves. It is a very complex system, which consists of a great number of items with various functions. In this study some limitations and assumptions are made to simplify the system for the purpose of the reliability analysis. Only the components, which are considered to be critical for the production and reliability of the system and can be exposed to falling free objects are used in the FMECA assessment. Many components from OREDA Reliability Data Handbook are not used in the analysis, such as XMT's items including a tubing hanger, a wellhead, injection valves, corresponding connectors and instrumentation for monitoring and measuring the flow.

For the purpose of the analysis, a typical template/manifold system is chosen which consists of six wells and six XMTs respectively. It is considered that if one XMT fails due to dropped object impact, the system will stop producing, which implies that the reliability analysis is performed with respect to one XMT. Maybe this scenario is not the most practicable and there might be different scenarios, which can be analyzed and assessed. It can be considered that if one or more XMT fails, the rest will continue to produce. That might improve the reliability of the system and will reduce the criticality of some of the components.

Typical functions of XMT are to direct and regulate the produced flow to the flowline, to monitor the well parameters, such as temperature, pressure, sand detection etc. One of the main functions is to act as a barrier between the reservoir and the environment during operations by controlling and monitoring the well. This is not taken into consideration in the

analysis. All monitoring devices on the XMT are eliminated, such as pressure and temperature transmitters. The monitoring equipment is considered to be not critical for the system performance in terms of dropped objects analysis and with very low probability of failures. Also the instrumentation equipment can be designed redundant to the degree close to negligible. The scope is limited based on the personal judgment and decision. This might influence the overall evaluation of the system due to reliability performance of the template manifold as a whole.

Pigging system is used in wax management to retrieve the deposition in the pipelines by injecting wax dispersant chemicals. It is very important for the system performance. A failure of some of the components will lead to inability of the system to reduce the depositions and will cause blockages and stop of the production. This is an event, which can be detected after long period, since the depositions need time to compose. If the failure is found in a short time, the accident can be avoided and the consequences can be reduced, hence a loss of production time and assets. The detection includes only visual inspection, which should be planned in the maintenance schedule. Moreover, most of the components' failures can be detected only by visual inspection. This makes the maintenance a very important part of the subsea structure design.

Most of the pigging module and XMT's components are plotted in the medium and low risk level region (connectors, valves, piping, FCM, SCM, etc.). The reason is that they are covered by protective structures and the template. The probability of failure of these components is low or very low, but the consequences if some of these items fail, might be severe for the production. However, the pigging module and the XMT components are estimated with medium or low risk level. An exception is the pigging module top plate and the XMT protection cover, which is not an unexpected finding, since their function is to protect the equipment.

The main functions of the manifold are to provide interface between the production pipelines and wells, to collect the produced fluids, to distribute electrical and hydraulic systems, and to distribute injection fluids. It has a significant importance for the production of hydrocarbons. In the risk matrix most of the manifold components are evaluated with medium and low risk level, such as connection modules, piping, and valve blocks. These components are very

significant for the production, but in terms of failure due to dropped objects, the probability of some of them to fail is low, since they are covered by the template and the manifold protective structure. A damage of these structures will cause failure of the components. So the protective elements of the manifold are estimated with high frequency of occurrence and severity and they are located in the high risk level region.

The main source for reliability data described in this report in Chapter 2 is OREDA Offshore Reliability Data Handbook. It contains information about the subsea equipment, failure modes and failure rates for a wide range of equipment used in oil and gas exploration and production. During the work execution, it was found that the database from OREDA is not relevant to this study, since the main purpose of this thesis is estimation of the most critical components of the system with respect to dropped objects impact. The collected data includes information about the components and corresponding failure modes, which are recorded, during the period of surveillance. The failure event is defined as a physical failure of the equipment during its lifetime, which implies that the failure does not occur due to any external impact. Also it can be seen that failure modes are obtained with respect to physical failures of the items and a failure rate is estimated as a function of time or an age of an item due to the probability that an item has survived up to specific time.

In FMECA sheet in APENDIX B, failure modes are listed due to dropped object impact and the damage they will cause to the components. The failure rate is estimate due to the potential frequency of falling object on the equipment and also very important consideration is the location of the equipment item. The template is the construction, which is exposed to direct impact of dropped objects, hence the failure rate of its elements is with highest probability of occurrence. The manifold, the pigging module and the XMTs and their components are actually protected by the template, thus the frequency of failure is estimated with lower magnitude than the protection structure. Properly speaking these three subunits will fail due to dropped objects impact only if the protection cover failed and it is not capable to perform its protective functions.

Also many components, such as connectors, piping, jumpers, valves, are housed in the subunits (a manifold, a pigging module and XMTs), which means they are double protected, firstly by the corresponding subunit and secondly by the template. The probability of failure

of the template and the manifold (and/or other subunit) to occur at the same time is very low. This implies the low frequency of failure of these components in the reliability analysis and locates them in the medium or low risk level in the risk matrix.

Failures, which are caused by dropped object are not observed and recorded in the database. There is no reliability and maintenance data collect due to the industry's experience. As there is a lack of relevant information about failure modes and failure rates, these parameters are estimated according to personal judgments and consideration, which includes a lot of uncertainties and subjective assessments.

The analysis performed in FMECA sheet shows that the template protection cover, unlike the rest of the components, has three operational modes – production, intervention and installation. This implies it is involved in any offshore operations and is important not only for the production, but also when to install the equipment and when maintenance and repair activities are performed. It is considered in the analysis that all operational modes will lead to each of the local and global effects described for one component. However, this is not applicable in case of installation mode. When the template is lifted during installation, it does not perform as a protection function and the rest of the template/ manifold's equipment is actually not protected. In this case, the template can be considered to be a dropped object with very large impact and catastrophic consequences for the production. This is not taken into account in the analysis, since the focus is on the template reliability assessment.

Dropped objects may have different impact energy, which is influenced by several factors, including the mass and the shape of the object, the water depth and the currents. In the analysis the different impact of dropped objects is not taken into account. It is considered that any dropped object will cause the same effect. In practice it is applicable to estimate the reliability of the system according to different impact energy. Not all of the falling objects may cause catastrophic damage on the equipment, which will lead to production cease. Some of the objects have very small size and mass, hence the impact energy is negligible. Others may cause damage on the equipment, but this will not result in a catastrophic consequence for the production of hydrocarbons. Only dropped objects with impact energy larger than 50kJ have a potential to cause a significant damage on the system with severe consequences for the production.

The results obtained show that the template protection cover has a significant importance for the system protection and the system performance. All of the template components are estimated as critical components for the production with the highest severity and frequency and are located in the high risk level region in the criticality matrix. It is an expected finding considering the main function of the template is to protect the equipment. Accidents due to dropped object during offshore activities are frequently seen. Subsea equipment structures are very vulnerable and difficult to repair. Any accident may cause heavy property losses on subsea structures and hence loss of production time and funds. Large part of the multiwell system components are estimated with “catastrophic” consequences for the production of oil and gas. If these components fail, the production will stop and that will lead to loss of production time and financial losses. The risk reducing measure, which can be implemented to avoid failure if such kind of event occurs is adequate dropped object design of the protective structure. Hence a protection structure design for subsea equipment is necessary.

The standards used for design (for example NORSOK U – 002) only provide a reference point for dropped object load and impact determination, but do not clearly specify the design method. The results obtained from this study prove that the design method and database are instantly needed and they will have extensive application in the subsea field development.

6 CHAPTER: CONCLUSIONS AND RECOMENDATIONS

In this master thesis, the main objective was an estimation of the most critical components of the multiwell template/manifold system with respect to the production if the system is exposed to dropped objects impact. The assessment was performed by using Failure Modes and Effects Criticality Analysis (FMECA). This approach allowed detailed study to be performed and all system components to be estimated and analyzed. According to the failure rate and the severity of occurrence, the components were plotted in the criticality matrix. The results obtained from the matrix indicated three components, which were most critical for the production – top plate, horizontal beam and wellbay hatches situated on the template protective structure. Also it can be seen that not only these components but all the element of template protective structure had a high risk level. This is an expected conclusion, which explains the protective functions of the template.

The results obtained from the analysis, indicates that the subsea protection design has a significant importance for the offshore industry. Accidents due to dropped objects during different offshore activities, such as installations of subsea structures, lifting the equipment, drilling and other operations, are frequently experienced. A damage of the subsea equipment in most of the cases leads to a production loss, a downtime and has severe consequences for the environment, which also reflects the financial assets. An adequate protection structure design is the only measure that can be implemented to avoid risk of failure due to dropped objects. Therefore the design method for subsea protection structures should be improved and clearly specified in standards and regulations.

It also might be useful if a reliability database will be created with respect to dropped object failure of the equipment. So thus the failure rate and severity can be obtained for each items based on maintenance data and offshore experience and can be properly used in the analysis. Then FMECA can be adequately applied for evaluation of the risk related not only to dropped objects accidents, but also to other third party activities.

When estimating the impact of dropped objects on the subsea structures, the various shapes and mass might be taken into account for the analysis. This will influence the results for the

reliability of the system and will lead to different consequences for the production when the system is hit by falling objects.

Several assumptions are made through the analysis in this study. Only one XMT is considered for evaluation the risk. It might be useful if all possible cases are considered and analyzed with two, three or more XMTs. This may give a different picture of the reliability of the system and the criticality.

REFERENCES

- 1 Aven, T., 2008. *Risk Analysis*. Chichester: John Wiley & Sons Ltd..
- 2 Bai, Y. & Bai, Q., 2012. *Subsea Ingeneering Handbook*. Kidlington: Elsevier Inc..
- 3 Christou, M. & Konstantinidou, M., 2012. *Safety of offshore oil and gas operations: Lessons from past accident analysis*, Italy: Joint Research Centre of the European Commission.
- 4 Drops, 2010. *Dropsonline*. [Online]
Available at: <http://www.dropsonline.org/assets/documents/DROPS-SubseaDROPS.pdf>
[Accessed 8 June 2016].
- 5 FMC Technologies, 2006. *Subsea Tie-in system*, Kongsberg: FMC Technology.
- 6 Gudmestad, O., Trbojevic, V. & Rettedal, W., 2008. *Risk Analysis for Offshore Installation, Modification and Removal Projects*, Stavanger: s.n.
- 7 Jansen, E., 2013. *Subsea Structures*, Stavanger: University of Stavanger.
- 8 Leong, W., 2012. *Dropped Object Prevention Scheme (DROPS) - An Asia Pacific Perspective*, Perth: Society of Petroleum Engineers.
- 9 NORSOK N-004, 2004. *Design of steel structures*. Lysaker: Standarts Norway.
- 10 Norsok Standards, 2015. *Norsok Standards*. [Online]
Available at: <https://www.standard.no/en/sectors/energi-og-klima/petroleum/norsok-standards/#.Vvpz0-J97Dc>
[Accessed 29 March 2016].
- 11 NORSOK U-002, 1998. *Subsea structures and piping system*. Oslo: Norwegian Technology Standart Institution.
- 12 NORSOK Z - 008, 2001. *Criticality analysis for maintenance purposes*. Oslo: Norwegian Technology Centre.
- 13 NORSOK Z - 016, 1998. *Regularuty Management and Reliability Technology*. Oslo: Norwegian Technology Centre.
- 14 Parker-Hannifin Inc., 2016. *High Pressure Subsea Ball Valves*. [Online]
Available at:
http://www.autoclave.com/products/ball_valves/subsea_ball_valves/index.html
[Accessed 2 April 2016].

- 15 Petrowiki, 2015. *Pipeline pigging*. [Online]
Available at: http://petrowiki.org/Pipeline_pigging
[Accessed 15 May 2016].
- 16 Rausand, M. & Høyland, A., 2004. *SYSTEM RELIABILITY THEORY: Models, Statistical Methods, and Applications*. Second ed. Hoboken: John Wiley & Sons, Ltd.
- 17 Sari, A., Azimov, U. & Nguyen, H., 2016. *Dropped Objects Assessment of Subsea Assets and Pipeline Protection System*, Kuala Lumpur: Offshote Technology Conference.
- 18 SINTEF, 2009. *OREDA: Offshore Reliability Data*. Fifth ed. Throndeim: OREDA Participants.
- 19 Stendebakken, O. I., 2014. *A reliability study of a Deep water vertical Xmas tree with attention to XT retrieval rate*, Trondheim: NTNU Trondheim.
- 20 Subsea 1 AS, 2013. *Subsea facilities overview*. [Online]
Available at: http://subsea1.com/index/page?keyword=xmas_tree
[Accessed 4 May 2016].
- 21 Worldwide Oilfield Machine, 2016. *Magnum Subsea Gate Valve*. [Online]
Available at: <http://www.womusa.com/wom-product/magnum-subsea-gate-valve/>
[Accessed 2 April 2016].

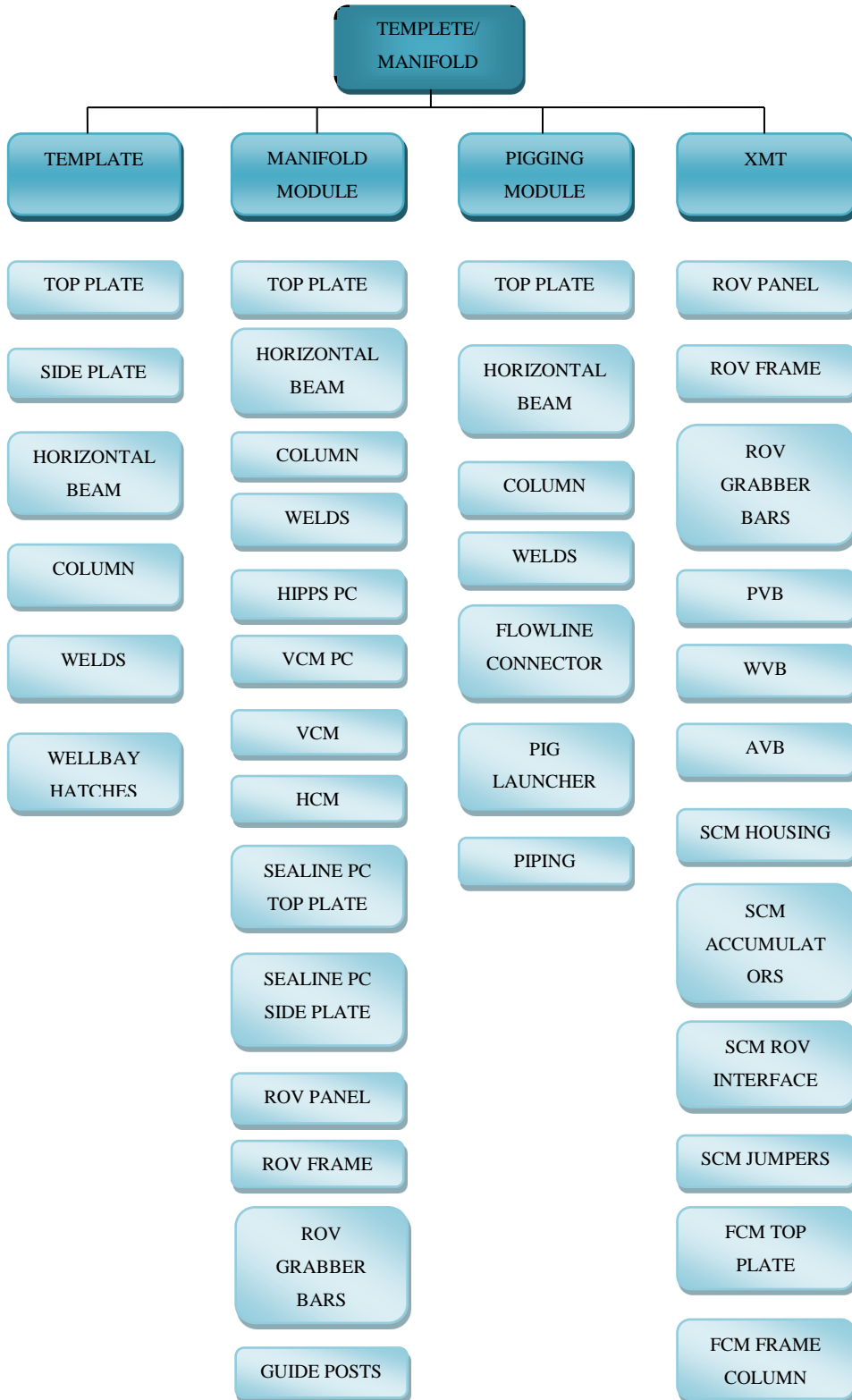

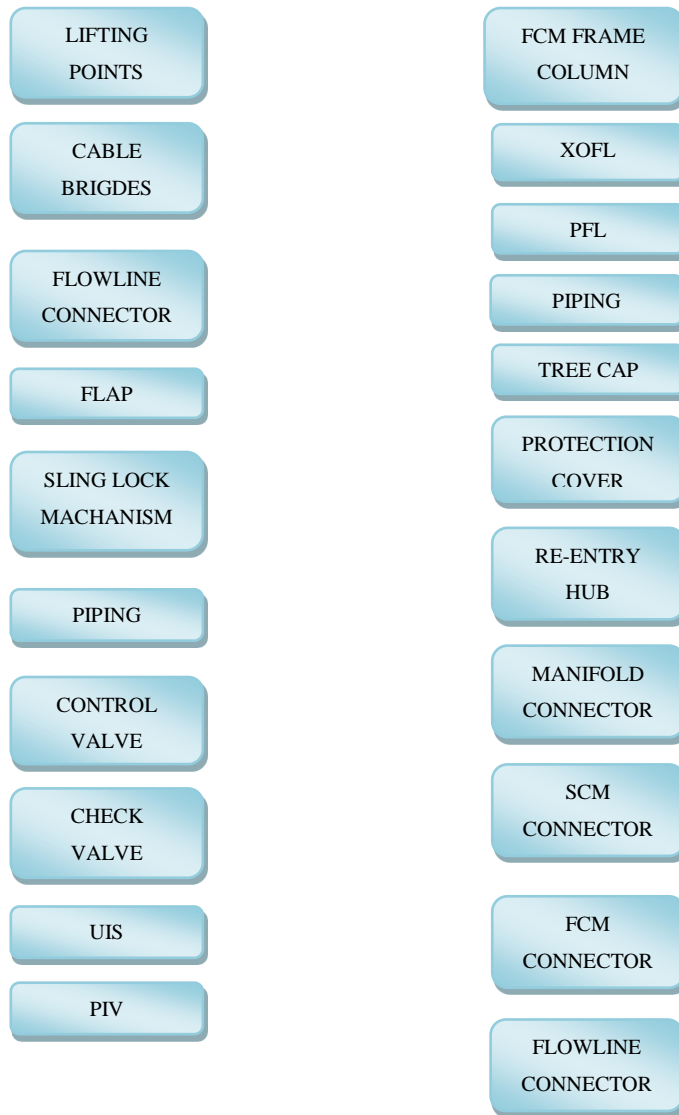

Figure 23: Breakdown structure of the system

Table 9: FMECA

Subunit	Description of components				Description of failure			Effect of failure		Failure rate	Severity ranking	Risk reducing measure
	Ref. no	Component	Function	Operational mode	Failure mode	Failure mechanism	Detection of failure	Local effect	Global effect			
Template (protective structure)	1	Top plate	Protect the equipment	1. Production 2. Intervention 3. Installation	1. Buckling 2. Shearing	Impact load due to dropped object	Visual inspection	1. Deformation of the structural element 2. Shearing off of the structural element 3. Tearing off of the structural element	1. Damage on the XMT components 2. Damage on the manifold components 3. Damage on the pigging module components 4. Stop production	Probable	Catastrophic	Dropped object design
	2	Side plate	Protect the equipment	1. Production 2. Intervention 3. Installation	1. Buckling 2. Shearing	Impact load due to dropped object	Visual inspection	1. Deformation of the structural element 2. Shearing off of the structural element 3. Tearing off of the structural element	1. Loss of structure integrity 2. Damage on the XMT components 3. Damage on the manifold components 4. Damage on the pigging module components 5. Stop production	Occasional	Catastrophic	Dropped object design

3	Horizontal beam	Support the equipment protection plate	1. Production 2. Intervention 3. Installation	1. Buckling 2. Shearing	Impact load due to dropped object	Visual inspection	1. Deformation of the structural element 2. Shearing off of the structural element 3. Tearing off of the structural element	1. Loss of structure integrity 2. Damage on the XMT components 3. Damage on the manifold components 4. Damage on the pigging module components 5. Stop production	Probable	Catastrophic	Dropped object design
4	Column	Support the equipment protection plate	1. Production 2. Intervention 3. Installation	1. Buckling 2. Shearing	Impact load due to dropped object	Visual inspection	1. Deformation of the structural element 2. Shearing off of the structural element 3. Tearing off of the structural element	1. Loss of structure integrity 2. Damage on the XMT components 3. Damage on the manifold components 4. Damage on the pigging module components 5. Stop production	Occasional	Catastrophic	Dropped object design
5	Welds	Connect the equipment elements	1. Production 2. Intervention 3. Installation	Cracking	Impact load due to dropped object	Visual inspection	1. Cracking of the element 2. Distortion of the element	1. Loss of structure integrity 2. Damage on the XMT components 3. Damage on the manifold components 4. Damage on the pigging module components 5. Stop production	Occasional	Catastrophic	Dropped object design

	6	Wellbay hatches	Protect the equipment	1. Production 2. Intervention 3. Installation	1. Buckling 2. Shearing	Impact load due to dropped object	Visual inspection	1. Deformation of the structural element 2. Shearing off of the structural element 3. Tearing off of the structural element	1. Loss of structure integrity 2. Damage on the XMT components 3. Damage on the manifold components 4. Damage on the pigging module components 5. Stop production	Probable	Catastrophic	Dropped object design
Manifold module	7	Top plate	Protect the equipment	Operation	1. Buckling 2. Shearing	Impact load due to dropped object	Visual inspection	1. Deformation of the structural element 2. Shearing off of the structural element 3. Tearing off of the structural element	1. Damage on the manifold components 2. Stop production	Occasional	Catastrophic	Dropped object design
	8	Horizontal beam	Support the equipment protection plate	Operation	1. Buckling 2. Shearing	Impact load due to dropped object	Visual inspection	1. Deformation of the structural element 2. Shearing off of the structural element 3. Tearing off of the structural element	1. Loss of structure integrity 2. Damage on the manifold components 3. Stop production	Remote	Catastrophic	Dropped object design
	9	Column	Support the equipment protection plate	Operation	1. Buckling 2. Shearing	Impact load due to dropped object	Visual inspection	1. Deformation of the structural element 2. Shearing off of the structural element 3. Tearing off of the structural element	1. Loss of structure integrity 2. Damage on the manifold components 3. Stop production	Remote	Catastrophic	Dropped object design
	10	Welds	Connect the equipment elements	Operation	Cracking	Impact load due to dropped object	Visual inspection	1. Cracking of the element 2. Distortion of the element	1. Loss of structure integrity 2. Damage on the manifold components 3. Stop production	Remote	Catastrophic	Dropped object design

11	HIPPS protection cover	Protect the equipment	Operation	1. Buckling 2. Shearing	Impact load due to dropped object	Visual inspection	1. Deformation of the structural element 2. Shearing off of the structural element 3. Tearing off of the structural element	1. Damage on the HIPPS 2. Stop production	Occasional	Catastrophic	Dropped object design
12	VCM Protection cover	Protect VCM	Operation	1. Buckling 2. Shearing	Impact load due to dropped object	Visual inspection	1. Deformation of the structural element 2. Shearing off of the structural element 3. Tearing off of the structural element	1. Damage on the VCM 2. Stop production	Occasional	Catastrophic	Dropped object design
13	Vertical connection module	Provide connection for flowlines	Operation	1. Structural damage 2. Misalignment	Impact load due to dropped object	Visual inspection	1. Deformation of the component 2. Fracture of the component	1. Loss of containment 2. External leakage 3. Stop production	Remote	Catastrophic	1. Protective structure 2. Dropped object design
14	Horizontal connection module	Provide connection for flowlines	Operation	1. Structural damage 2. Misalignment	Impact load due to dropped object	Visual inspection	1. Deformation of the component 2. Fracture of the component	1. Loss of containment 2. External leakage 3. Stop production	Remote	Catastrophic	1. Protective structure 2. Dropped object design
15	Sealine PC top plate	Protect the equipment	Operation	1. Buckling 2. Shearing	Impact load due to dropped object	Visual inspection	1. Deformation of the structural element 2. Shearing off of the structural element 3. Tearing off of the structural element	1. Damage on the tie-in system 2. Stop production	Occasional	Catastrophic	Dropped object design
16	Sealine PC side plate	Protect the equipment	Operation	1. Buckling 2. Shearing	Impact load due to dropped object	Visual inspection	1. Deformation of the structural element 2. Shearing off of the structural element 3. Tearing off of the structural element	1. Damage on the tie-in system 2. Stop production	Remote	Catastrophic	Dropped object design

17	ROV panel	Operate manifold valves	1. Operation 2. Installation	1. Structural damage 2. Misalignment	Impact load due to dropped object	1. Visual inspection 2. Difficulty in executing the operation	Fracture of the component	Inability to operate the valves remotely	Remote	Major	1. Protective structure 2. Dropped object design
18	ROV frame	Support ROV panel	1. Operation 2. Installation	1. Buckling 2. Shearing	Impact load due to dropped object	1. Visual inspection 2. Difficulty in executing the operation	1. Deformation of the structural element 2. Shearing off of the structural element 3. Tearing off of the structural element	1. Damage on the ROV panel 2. Inability to operate the valves remotely. 3. Difficulty in executing the operation	Occasional	Major	1. Protective structure 2. Dropped object design
19	ROV grabber bars	Support ROV operations	1. Operation 2. Installation	1. Buckling 2. Shearing	Impact load due to dropped object	Visual inspection	1. Deformation of the structural element 2. Shearing off of the structural element 3. Tearing off of the structural element	Inability of the ROV to operate	Occasional	Major	1. Protective structure 2. Dropped object design
20	Lifting points	Support lifting operations	1. Installation 2. Intervention	1. Buckling 2. Shearing in the welds	Impact load due to dropped object	1. Visual inspection 2. Difficulty in successful lifting	1. Deformation of the component 2. Fracture of the component	Inability to lift the manifold module	Occasional	Minor	1. Protective structure 2. Dropped object design
21	Guide posts	Guide the manifold during installation	Installation	1. Buckling 2. Misalignment	Impact load due to dropped object	1. Visual inspection 2. Difficulty in installation of manifold	1. Deformation of the component 2. Fracture of the component	Inability to install the manifold module	Occasional	Minor	1. Protective structure 2. Dropped object design
22	Cable bridges	Rout the cables	Operation	Structural damage	Fatigue damage	Visual inspection	1. Deformation of the component 2. Fracture of the component	1. Damage of the cables 2. Loss of electricity supply 3. Stop production	Very unlikely	Critical	1. Protective structure 2. Dropped object design
23	Flowline connector	Connect the flowlines	Operation	1. Shearing of the bolts 2. Misalignment of the flanges	Impact load due to dropped object	Visual inspection	1. Deformation of the component 2. Fracture of the component	1. Loss of containment 2. External leakage 3. Stop production	Very unlikely	Catastrophic	1. Protective structure 2. Dropped object design

24	Flap	Increase the access to the hubs	Operation	Structural damage	Impact load due to dropped object	Visual inspection	1. Deformation of the component 2. Fracture of the component	Difficulty in accessing the hubs	Very unlikely	Minor	1. Protective structure 2. Dropped object design
25	Sling lock mechanism	Lock the lifting sling	1. Installation 2. Intervention	Structural damage	Impact load due to dropped object	Visual inspection	1. Deformation of the component 2. Fracture of the component	1. Inability to lock the slings 2. Inability to install the manifold module 3. Inability to lift the manifold module	Remote	Minor	1. Protective structure 2. Dropped object design
26	Piping (hard pipe)	Conduit for flow	Operation	1. Buckling 2. Shearing of the welds 3. Rupture 4. Misalignment at the flanges	Impact load due to dropped object	1. Visual inspection 2. Abnormal pressure loss in sensors	1. Deformation of the component 2. Fracture of the component	1. Loss of containment 2. External leakage. 3. Stop production	Very unlikely	Critical	1. Protective structure 2. Dropped object design
27	Control valve	1. Regulate the flow 2. Regulate the pressure	Operation	1. Structural damage 2. Misalignment of the flanges 3. Shearing of the bolts	Impact load due to dropped object	1. Visual inspection 2. Topside monitoring 3. Abnormal pressure loss in sensors	Fracture of the component	1. Uncontrolled flow in the system 2. Uncontrolled pressure in the system 3. External leakage	Very unlikely	Critical	1. Protective structure 2. Dropped object design
28	Check valve	Prevent back flow	Operation	Structural damage	Impact load due to dropped object	1. Visual inspection 2. Topside monitoring 3. Abnormal pressure loss in sensors	Fracture of the component	1. Occurrence of backflow 2. External leakage	Very unlikely	Critical	1. Protective structure 2. Dropped object design
29	Utility isolation valve	1. Conduit for flow 2. Isolate the system from back flow	Intervention	Structural damage	Impact load due to dropped object	1. Visual inspection 2. Topside monitoring 3. Abnormal pressure loss in sensors	Fracture of the component	1. Loss of containment 2. External leakage 3. Occurrence of backflow	Very unlikely	Critical	1. Protective structure 2. Dropped object design

	30	Process isolation valve	1. Conduit for flow 2. Isolate the system from back flow	Intervention	Structural damage	Impact load due to dropped object	1. Visual inspection 2. Topside monitoring 3. Abnormal pressure loss in sensors	Fracture of the component	1. Loss of containment 2. External leakage 3. Occurrence of backflow	Very unlikely	Critical	1. Protective structure 2. Dropped object design
Pigging module	31	Top plate	Protect the equipment	Operation	1. Buckling 2. Shearing	Impact load due to dropped object	Visual inspection	1. Deformation of the structural element 2. Shearing off of the structural element 3. Tearing off of the structural element	1. Damage on the pigging module components 2. Inability to reduce the deposition in the system 3. Blockage in the system 4. Stop production	Occasional	Catastrophic	Dropped object design
	32	Horizontal beam	Protect the equipment	Operation	1. Buckling 2. Shearing	Impact load due to dropped object	Visual inspection	1. Deformation of the structural element 2. Shearing off of the structural element 3. Tearing off of the structural element	1. Loss of structure integrity 2. Damage on the pigging module components 3. Inability to reduce the deposition in the system 4. Blockage in the system 5. Stop production	Remote	Catastrophic	Dropped object design
	33	Column	Protect the equipment	Operation	1. Buckling 2. Shearing	Impact load due to dropped object	Visual inspection	1. Deformation of the structural element 2. Shearing off of the structural element 3. Tearing off of the structural element	1. Loss of structure integrity 2. Damage on the pigging module components 3. Inability to reduce the deposition in the system 4. Blockage in the system 5. Stop production	Remote	Catastrophic	Dropped object design

34	Welds	Connect the equipment elements	Operation	Cracking	Impact load due to dropped object	1. Visual inspection 2. Vibrations	1. Cracking of the element 2. Distortion of the element	1. Loss of structure integrity 2. Damage on the pigging module components 3. Inability to reduce the deposition in the system 4. Blockage in the system 5. Stop production	Remote	Catastrophic	Dropped object design
35	Flowline connector	Connect the pipelines	Operation	1. Shearing of the bolts 2. Misalignment of the flanges	Impact load due to dropped object	1. Visual inspection 2. Vibrations	1. Deformation of the component 2. Fracture of the component	1. Loss of containment 2. External leakage of chemicals 3. Inability to reduce the deposition in the system 3. Blockage in the system 4. Stop production	Very unlikely	Major	1. Protective structure 2. Dropped object design
36	Pig launcher	Launch the pig	Maintenance	1. Buckling 2. Shearing of the welds 3. Rupture 4. Misalignment at the flanges	Impact load due to dropped object	Visual inspection	1. Deformation of the component 2. Fracture of the component	1. Loss of containment 2. External leakage of chemicals 3. Inability to reduce the deposition in the system 4. Blockage in the system 5. Stop production	Very unlikely	Catastrophic	1. Protective structure 2. Dropped object design
37	Piping (hard pipe)	Conduit for flow	Operation	1. Buckling 2. Shearing of the welds 3. Rupture 4. Misalignment at the flanges	Impact load due to dropped object	Visual inspection	1. Deformation of the component 2. Fracture of the component	1. Loss of containment 2. External leakage of chemicals 3. Inability to reduce the deposition in the system 4. Blockage in the system 5. Stop production	Very unlikely	Catastrophic	1. Protective structure 2. Dropped object design

XMT	38	ROV panel	Operate XMT valves	1. Operation 2. Installation	1. Structural damage 2. Misalignment	Impact load due to dropped object	Visual inspection	Fracture of the component	Inability to operate the valves remotely	Remote	Major	1. Protective structure 2. Dropped object design
	39	ROV frame	Support ROV panel	1. Operation 2. Installation	1. Buckling 2. Shearing	Impact load due to dropped object	Visual inspection	1. Deformation of the structural element 2. Shearing off of the structural element 3. Tearing off of the structural element	1. Damage on the ROV panel 2. Inability to operate the valves remotely	Occasional	Major	1. Protective structure 2. Dropped object design
	40	ROV grabber bars	Support ROV operations	1. Operation 2. Installation	1. Buckling 2. Shearing	Impact load due to dropped object	Visual inspection	1. Deformation of the structural element 2. Shearing off of the structural element 3. Tearing off of the structural element	Inability of the ROV to operate	Occasional	Major	1. Protective structure 2. Dropped object design
	41	PVB	1. Conduit for flow 2. House the valves	Operation	Structural damage	Impact load due to dropped object	1. Visual inspection 2. Topside monitoring 3. Abnormal pressure loss in sensors	Fracture of the component	1. Loss of containment 2. External leakage	Very unlikely	Critical	1. Protective structure 2. Dropped object design
	42	WVB	1. Conduit for flow 2. House the valves	Operation	Structural damage	Impact load due to dropped object	1. Visual inspection 2. Topside monitoring 3. Abnormal pressure loss in sensors	Fracture of the component	1. Loss of containment 2. External leakage	Very unlikely	Critical	1. Protective structure 2. Dropped object design
	43	AVB	1. Conduit for flow 2. House the valves	Operation	Structural damage	Impact load due to dropped object	1. Visual inspection 2. Topside monitoring 3. Abnormal pressure loss in sensors	Fracture of the component	1. Loss of containment 2. External leakage in annulus line	Very unlikely	Critical	1. Protective structure 2. Dropped object design

44	SCM housing	House the SCM	Operation	Structural damage	Impact load due to dropped object	Visual inspection	1. Deformation of the component 2. Fracture of the component	1. Damage of the SCM components 2. Inability to operate the system	Very unlikely	Major	1. Protective structure 2. Dropped object design
45	SCM accumulators	Provide hydraulic supply	Operation	1. Cracking 2. Rupture	Impact load due to dropped object	1. Visual inspection 2. Topside monitoring 3. Abnormal pressure loss in sensors	Fracture of the component	1. Loss of hydraulic supply 2. Inability to operate the system	Very unlikely	Major	1. Protective structure 2. Dropped object design
46	SCM ROV interface	Lock/unlock from the base	Operation	1. Structural damage 2. Misalignment	Impact load due to dropped object	Visual inspection	Fracture of the component	Inability to operate the SCM remotely	Remote	Major	1. Protective structure 2. Dropped object design
47	SCM jumpers	Conduit for flow	Operation	1. Buckling 2. Shearing of the welds 3. Rupture 4. Misalignment at the flanges	Impact load due to dropped object	Visual inspection	1. Deformation of the component 2. Fracture of the component	1. Loss of containment 2. External leakage 3. Stop production	Very unlikely	Catastrophic	1. Protective structure 2. Dropped object design
48	FCM frame top plate	Protect the equipment	Operation	1. Buckling 2. Shearing	Impact load due to dropped object	Visual inspection	1. Deformation of the structural element 2. Shearing off of the structural element 3. Tearing off of the structural element	1. Damage on the FCM components 2. Inability to regulate the wellflow	Occasional	Major	1. Protective structure 2. Dropped object design
49	FCM frame column	Support the equipment protection frame	Operation	1. Buckling 2. Shearing	Impact load due to dropped object	Visual inspection	1. Deformation of the structural element 2. Shearing off of the structural element 3. Tearing off of the structural element	1. Loss of structure integrity 2. Damage on the FCM components 3. Inability to regulate the wellflow	Remote	Major	1. Protective structure 2. Dropped object design

50	FCM frame beam	Support the equipment protection frame	Operation	1. Buckling 2. Shearing	Impact load due to dropped object	Visual inspection	1. Deformation of the structural element 2. Shearing off of the structural element 3. Tearing off of the structural element	1. Loss of structure integrity 2. Damage on the FCM components 3. Inability to regulate the wellflow	Remote	Major	1. Protective structure 2. Dropped object design
51	XOFL	Conduit for flow	Operation	1. Buckling 2. Shearing of the welds 3. Rupture 4. Misalignment at the flanges	Impact load due to dropped object	Visual inspection	1. Deformation of the component 2. Fracture of the component	1. Loss of containment 2. External leakage 3. Stop production	Very unlikely	Catastrophic	1. Protective structure 2. Dropped object design
52	PFL	Conduit for flow	Operation	1. Buckling 2. Shearing of the welds 3. Rupture 4. Misalignment at the flanges	Impact load due to dropped object	Visual inspection	1. Deformation of the component 2. Fracture of the component	1. Loss of containment 2. External leakage 3. Stop production	Very unlikely	Catastrophic	1. Protective structure 2. Dropped object design
53	Piping (hard pipe)	Conduit for flow	Operation	1. Buckling 2. Shearing of the welds 3. Rupture 4. Misalignment at the flanges	Impact load due to dropped object	1. Visual inspection 2. Vibrations	1. Deformation of the component 2. Fracture of the component	1. Loss of containment 2. External leakage 3. Stop production	Very unlikely	Catastrophic	1. Protective structure 2. Dropped object design
54	Tree cap	Barrier against the bores	Operation	1. Structural damage 2. Misalignment	Impact load due to dropped object	Visual inspection	1. Deformation of the component 2. Fracture of the component	Sea water ingress	Occasional	Minor	1. Protective structure 2. Dropped object design
55	Protection cover	Protect the equipment	Operation	1. Buckling 2. Shearing	Impact load due to dropped object	Visual inspection	1. Deformation of the structural element 2. Shearing off of the structural element 3. Tearing off of the structural element	1. Damage on the XMT components 2. Stop production	Occasional	Catastrophic	1. Protective structure 2. Dropped object design

56	Re-entry hub	1. Regulate the flow 2. Connect to the wellhead	Operation	1. Structural damage 2. Misalignment	Impact load due to dropped object	1. Visual inspection 2. Vibrations 3. Loss in pressure	1. Deformation of the component 2. Fracture of the component	1. Inability to regulate the wellflow 2. External leakage 3. Stop production	Remote	Catastrophic	1. Protective structure 2. Dropped object design
57	Manifold connector	Connect XMT to the manifold	Operation	1. Shearing of the bolts 2. Misalignment of the flanges	Impact load due to dropped object	1. Visual inspection 2. Vibrations	1. Deformation of the component 2. Fracture of the component	1. Loss of containment 2. External leakage 3. Stop production	Very unlikely	Catastrophic	1. Protective structure 2. Dropped object design
58	SCM connector	Connect the XMT to the SCM	Operation	1. Shearing of the bolts 2. Misalignment of the flanges	Impact load due to dropped object	1. Visual inspection 2. Vibrations	1. Deformation of the component 2. Fracture of the component	1. Loss of containment 2. External leakage 3. Stop production	Very unlikely	Catastrophic	1. Protective structure 2. Dropped object design
59	FCM connector	Connect the XMT to the flowlines	Operation	1. Shear of the bolts 2. Misalignment of the flanges	Impact load due to dropped object	1. Visual inspection 2. Vibrations	1. Deformation of the component 2. Fracture of the component	1. Loss of containment 2. External leakage 3. Stop production	Very unlikely	Catastrophic	1. Protective structure 2. Dropped object design
60	Flowline connector	Connect the flowlines	Operation	1. Shearing of the bolts 2. Misalignment of the flanges	Impact load due to dropped object	1. Visual inspection 2. Vibrations	1. Deformation of the component 2. Fracture of the component	1. Loss of containment 2. External leakage 3. Stop production	Very unlikely	Catastrophic	1. Protective structure 2. Dropped object design