

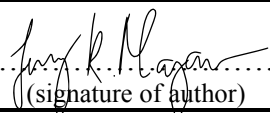

Universitetet  
i Stavanger

FACULTY OF SCIENCE AND TECHNOLOGY

## MASTER'S THESIS

Study programme/specialisation: <b>Environmental Monitoring and Nature Management in the Northern Oil and Gas Producing Regions</b>	Spring / <del>Autumn</del> semester, 2018..  Open/ <del>Confidential</del>
Author: <b>Jenny Kristine Mazarino</b>	.....  (signature of author)
Programme coordinator: <b>Roald Kommedal</b>  Supervisor(s): <b>Roald Kommedal and Anders Wold</b>	
Title of master's thesis: <b>Anaerobic Co-digestion of Aquaculture and Municipal Waste</b>	
Credits: <b>30</b>	
Keywords: <i>Anaerobic digestion</i> <i>Co-digestion</i> <i>Biogas production</i> <i>Waste management</i> <i>Aquaculture waste</i> <i>Municipal waste</i>	Number of pages: <b>70</b> .....  + supplemental material/other: <b>0</b> .....  Stavanger, <b>June 15th/2018</b> ..... date/year

**ANAEROBIC CO-DIGESTION OF AQUACULTURE AND MUNICIPAL WASTE**

MASTER'S THESIS



Universitetet  
i Stavanger

Jenny Kristine Mazarino

ENVIRONMENTAL MONITORING AND NATURE MANAGEMENT  
DEPARTMENT OF CHEMISTRY, BIOSCIENCE AND ENVIRONMENTAL ENGINEERING  
UNIVERSITY OF STAVANGER  
2018

## Abstract

This study describes anaerobic co-digestion of aquaculture waste from Fister Smolt and municipal waste from IVAR SNJ. Both waste types are in rapid increase worldwide, yet production of biogas has mainly considered municipal waste as substrate thus far. There is a knowledge gap in the current understanding of co-digestion of aquaculture and municipal waste, and research and development are required.

The main objective of this study was to evaluate the biogas production potential and the stability of this co-digestion process. The biogas production potential and methane yield were assessed in anaerobic batch tests using the AMPTS II system. Produced methane corresponded to the amount of COD entering the batch test system, and around 70% COD of the aquaculture waste from Fister Smolt and the primary sludge from IVAR SNJ was converted to methane.

Results from the batch tests showed a 1% increase in methane yield when aquaculture waste and activated sludge from IVAR SNJ was co-digested. However, this value was regarded as too low to confirm an actual increase in methane yield. No increase in methane yield was observed when aquaculture and municipal waste was co-digested. Results from the daily fed stirred tank reactor showed a 6% increase in methane yield when aquaculture and municipal waste was co-digested. However, this value was also regarded as too low to confirm an actual increase in methane yield.

The process stability and performance were evaluated using daily fed stirred tank reactors. Four different reactors were set up with a SRT of 15 days. The primary sludge reactor and the co-digestion reactor experienced no inhibition. The aquaculture waste reactor experienced ammonia induced inhibition with an ammonia concentration of 50 mg/l, at a pH of 7.3 and an ammonium concentration of 1.6 g/l. An inhibited steady state was assumed when an increase in VFA concentration to 2100 mg/l reduced the ammonia concentration to 30 mg/l, as the pH was decreased. Methane was produced at a satisfying level. The pH adjusted aquaculture waste reactor on the other hand did not reach ammonia levels that were high enough to inhibit the performance of the reactor, and a more stable process was achieved.

It is possible to anaerobically digest aquaculture waste from Fister Smolt without adjustment of pH or co-digestion with primary sludge. However, nitrogen concentrations need to be closely monitored to avoid accumulation of ammonia.

## Acknowledgements

I would first and foremost like to thank my main advisor, Dr. Anders Wold, for his professional expertise, profound support and brilliant sense of humour.

I would also like to express my gratitude to my supervisor Assoc. Prof. Roald Kommedal, and the project participants IVAR IKS (Dr. Leif Ysdtebø), Aquateam COWI and Fister Smolt.

Special thanks to the employees and students at the University of Stavanger laboratories, in particular Hans Kristian Brekken, Liv Margareth Aksland, Anissa Sukma Saftiri, Eystein Opsahl, Nurul Aufa and Liva Mørenskog Luth-Hanssen.

Many thanks to my wise and encouraging colleagues at Skretting ARC.

## Table of Contents

Abstract .....	i
Acknowledgements .....	ii
List of figures .....	v
List of tables .....	vi
List of equations .....	vii
Abbreviations .....	viii
1. Introduction .....	1
2. Literature review and theoretical background .....	3
2.1 Waste production in aquaculture systems .....	3
2.1.1 Fister Smolt as .....	6
2.2 Microorganism growth and process parameters in anaerobic systems .....	9
2.3 Anaerobic digestion overview .....	13
2.4 Anaerobic digestion of aquaculture sludge .....	15
3. Objectives and scope of work .....	18
4. Materials and methods .....	20
4.1 The Automatic Methane Potential Test System (AMPTS) II .....	20
4.2 Anaerobic batch tests .....	21
4.3 Daily fed stirred tank reactors .....	24
4.4 Analytical methods .....	25
4.4.1 pH and conductivity measurements .....	25
4.4.2 Total solids and total volatile solids measurements .....	25
4.4.3 Total COD measurements .....	26
4.4.4 Volatile fatty acids and alkalinity measurements .....	27
4.4.5 Orthophosphate and total phosphorus measurements .....	27
4.4.6 Ammonium and total nitrogen measurements .....	28
4.5 Error and accuracy analysis .....	29
5. Results .....	30
5.1 Section 1: Sludge characteristics .....	30
5.2 Section 2: Batch tests .....	31
5.3 Section 3: Daily fed stirred tank reactors .....	37
5.3.1 Alkalinity and pH .....	37
5.3.2 Ammonium .....	39
5.3.3 Methane production and VFA .....	40
5.3.4 Steady state characteristics .....	42
5.3.5 Extended performance test .....	44
6. Discussion .....	49

6.1	Biogas production potential and sludge removal .....	49
6.1.1	Alkalinity and pH .....	51
6.2	Ammonia inhibition and operational strategies.....	53
7.	Conclusion.....	56
8.	References .....	58

## List of figures

Figure 1 Wastewater production from aquaculture industries (Siddiqui, 2003) .....	3
Figure 2 Sketch of recirculating aquaculture system (RAS) setup (Khater et al., 2011) .....	6
Figure 3 Distribution of ammonia and ammonium as a function of pH (Kunz & Mukhtar, 2016) .....	12
Figure 4 Metabolic pathways and microbial groups (Gueterbock & Sangosanya, u.d.).....	13
Figure 5 Substrate options for the methanogenesis step of anaerobic digestion (Vaccari, Strom, & Alleman, 2006) .....	14
Figure 6 Sketch of the Automatic Methane Potential Test System (AMPTS II) setup.....	21
Figure 7 Faith of COD influent in an anaerobic reactor (Henze et al., 2008) .....	22
Figure 8 Daily fed stirred tank reactor A1: Bioreactor, A2: Side ports, A3: Stopper with tube connection to unit B, A4: Feeding inlet (with clamp), A5: Sludge outlet (with clamp) .....	24
Figure 9 Methane production in batch test 1.0 .....	32
Figure 10 Flowrate of the methane production in batch test 1.0 .....	33
Figure 11 Methane production in batch test 2.0 .....	34
Figure 12 Flowrate of the methane production in batch test 2.0 .....	35
Figure 13 pH of the daily fed stirred tank reactors as a function of time .....	37
Figure 14 Alkalinity (as CaCO <sub>3</sub> ) of the daily fed stirred tank reactors as a function of time .....	38
Figure 15 Ammonium concentrations of the daily fed stirred tank reactors as a function of time .....	39
Figure 16 Methane production in the daily fed stirred tank reactors at day 16.....	40
Figure 17 Methane production (g COD/d) of the daily fed stirred tank reactors as a function of time .....	41
Figure 18 Volatile fatty acid concentrations(mg/l) of the daily fed stirred tank reactors as a function of time .....	41
Figure 19 pH of the daily fed stirred tank reactors 2 and 4 as a function of time .....	45
Figure 20 Volatile fatty acids concentration (mg/l) in the daily fed stirred tank reactors 2 and 4 as a function of time .....	46
Figure 21 Ammonia concentrations (mg/l) in the daily fed stirred tank reactors 2 and 4 as a function of time .....	47
Figure 22 Methane production (g COD/d) of the daily fed stirred tank reactors 2 and 4 as a function of time .....	48
Figure 23 pH as a function of pCO <sub>2</sub> estimated for the alkalinity in Table 13, Henrys constant of 0.0270 M/bar and CO <sub>2</sub> dissociation constant of $4.9431 \times 10^{-7} \text{M}$ .....	52
Figure 24 Estimated FAN based on pH measured in the DFSTR and a constant TAN of 1.6g/l .....	54

## List of tables

Table 1 Sludge characteristics determined by Aquateam for project purposes .....	4
Table 2 Composition of Atlantic salmon smolt sludge (Gebauer and Eikebrokk, 2006).....	5
Table 3 Estimation of produced dry sludge yearly in fish production (Matias del Campo, et al., 2010).....	5
Table 4 Characterization of sludge from Fister Smolt .....	7
Table 5 Biological function of some essential inorganic nutrients in fish feed (Food and Agriculture Organization of the United Nations u.d.) .....	8
Table 6 Operational conditions and sludge digestion efficiency of anaerobic digestion systems of sludge from RAS (Mirzoyan, Tal, & Gross, 2010) .....	17
Table 7 Setup of batch test 1.0 .....	22
Table 8 Setup of batch test 2.0 .....	23
Table 9 Setup of the DFSTR system .....	25
Table 10 Characteristic quality data and characteristic procedure data of cell test kits from Merk Spectroquant	29
Table 11 Sludge characteristics of substrates used in the experiments of this study .....	30
Table 12 Biomethane potential (BMP) of batch test 1.0 .....	35
Table 13 Biomethane potential (BMP) of batch test 2.0 .....	36
Table 14 COD steady state evaluation .....	42
Table 15 Total nitrogen steady state evaluation .....	42
Table 16 Total phosphorus steady state evaluation .....	43
Table 17 Sludge removal in the DFSTR .....	43
Table 18 Environmental conditions during steady state.....	44
Table 19 Measured alkalinity and calculated alkalinity from ammonium concentrations in the DFSTR .....	51
Table 20 Measured pCO <sub>2</sub> , calculated expected pH and measured overall pH in DFSTR .....	53



## List of equations

Equation 1 Equilibrium of total ammonia nitrogen, governed by pH and temperature .....	10
Equation 2 Production of carbonic acid, bicarbonate and carbonate from the release of carbon dioxide in water .....	11
Equation 3 Equilibrium between ammonia and ammonium .....	12
Equation 4 Equilibrium between ammonia and ammonium ions in water .....	12
Equation 5 Production of ammonium and bicarbonate from the release of ammonia and carbon dioxide in water .....	13
Equation 6 Theoretical methane production.....	21
Equation 7 Universal gas law .....	21
Equation 8 Calculation of TS .....	26
Equation 9 Calculation of TVS .....	26
Equation 10 Determination of $H^+$ concentration where $K_H$ is Henry's law constant expressed as $Mbar^{-1}$ and $K_C$ is the dissociation coefficient for $CO_2/HCO_3$ .....	52

## Abbreviations

AD	Anaerobic Digestion
ADM1	Anaerobic Digestion Model No.1
AMPTS II	Automatic Methane Potential Test System
COD	Chemical Oxygen Demand
CSTR	Continuous stirred tank reactor
DFSTR	Daily fed stirred tank reactor
FA	Free Ammonia
HAc	Acetic Acid
HRT	Hydraulic Retention Time
IVAR	Interkommuntalt vann, avløp og renovasjon
OLR	Organic Loading Rate
RAS	Recirculating Aquaculture System
R&D	Research and Development
SNJ	Sentralrenseanlegg Nord-Jæren
SRT	Solid/Sludge Retention Time
TAN	Total Ammonia Nitrogen
TN	Total Nitrogen
TP	Total Phosphorus
TS	Total Solids
TSS	Total Suspended Solids
UASB	Upflow Anaerobic Sludge Blanket Digestion
VFA	Volatile Fatty Acid
VS	Volatile Solids
VVS	Volatile Suspended Solids

# 1. Introduction

This study was a part of a project initiated by the municipality of Bergen (project manager), in cooperation with several other institutions including: Aquateam COWI (project supervisor), IVAR IKS, Bergen University College, the University of Stavanger, Norwegian Seafood Centre and Blue Planet. The project title was defined as “*Utilization of waste from marine food production for regional renewable energy*” with the aim of optimizing the utilization of organic resources (waste) available in the Western regions of Norway. The main goals of the project were:

- Finding the optimal co-digestion ratios for aquaculture waste and municipal waste.
- Finding the potential for increasing methane production by utilization of aquaculture waste.
- Improving the quality and the nutrient content in the waste products of the biogas process.

The Norwegian government has developed a strategy aiming to increase Norwegian biogas production and extract excess values from waste fractions that are currently not recycled (Klima- og miljødepartementet, u.d.). The focus of the strategy is on co-digestion of sludge and other co-substrates than only domestic waste, and waste fractions from the processing industry or the aquaculture industry are of current interest. According to the project application Norwegian fisheries were producing more than 550 000 ton of by-products in 2012, which accounts for more than 20% of all fish caught and farmed in Norway. The by-products include both whole fish and fish entrails (intestines, bones, skin, etc.). A majority of these by-products are currently being used as raw material for feed production, while an estimated 200 000 ton are dumped in the ocean (Rubin, 2012). However, there are no validated overview over the amount of waste from the aquaculture industry or land-based fish hatcheries. The quality of the fish sludge varies from facility to facility, based on water concentrations and salt contents. Sludge from fish hatcheries tend to have a lower salt concentration than other fish farming facilities, because fish hatcheries operates by using land-based vessels containing freshwater (Matias del Campo et al., 2010).

Biogas is an alternative energy resource under constant development in the Western regions of Norway. The amount of municipal and biological waste from industries such as aquaculture is

in increase, yet production of biogas has mainly considered municipal waste as substrate this far. Both Bergen (Water and wastewater governmental agency) and Stavanger (IVAR IKS) have biogas facilities under establishment that have capacity for including additional waste substrates in their operations, and both facilities are localized in areas that are well fit to receive aquaculture waste. Co-digestion of aquaculture and municipal waste could possibly increase biogas production and decrease operational costs of the biogas facilities. There is a knowledge gap in the current understanding of this co-digestion process, and research and development (R&D) is required. The final goal for the project is to promote use of co-digestion of municipal waste, domestic waste and aquaculture waste, by utilizing current capacity at existing biogas production facilities and to contribute to making anaerobic digestion the main waste treatment process in Norway.

During the run-time of the project, fish waste fractions and fish sludge will be evaluated and tested together with sludge from municipal wastewater treatment facilities. The main challenges the research of the project aims to solve includes:

- To obtain a stable biogas production process where substrates that are high in nitrogen are present.
- To obtain a stable biogas production process where substrates that are high in fats are present.
- To control other inhibiting components such as sulphur.
- To improve the availability of certain nitrogenous and phosphorus components in the process and in the by-products and recycle these.
- To establish a robust inoculum that is fit for aquaculture waste.
- To establish co-digestion ratios that will optimize the organic load and prevent accumulation of organic acids.
- To establish good operational procedures that continuously monitor parameters such as pH, alkalinity, volatile fatty acids (VFA), nitrogen, chemical oxygen demand (COD), sulphur and phosphorus.

To this date a similar study has not been conducted in Norway, however some R&D about utilization of aquaculture waste for biogas production and some studies regarding co-digestion with animal manure have been accomplished (Solli, Sørheim, & Briseid, 2014; Estevez et al., 2014; Fjørtoft et al., 2014). Different substrate ratio potentials can be investigated using the

Automatic Methane Potential Test System (AMPTS II) and succeeding ratios can be further investigated and tested using a continuous stirred tank reactor (CSTR). Data obtained from these experiments can prove relevant for full scale facilities. In this study the biogas potential and process stability of anaerobic treatment of aquaculture waste and municipal waste, with a particular focus on co-digestion, will be evaluated using these methods.

## 2. Literature review and theoretical background

### 2.1 Waste production in aquaculture systems

Waste production in aquaculture systems results from hatcheries and farming system operations (Figure 1). In 2016 there were a total of 117 companies licenced (187 licenses) for production of juvenile fish in Norway, with varying production authorizations from 1 000 000 to 13 000 000 smolts yearly (Fiskeridirektoratet, 2017). In 2013, 168 of the hatcheries had flow through systems, and 25 of these had recirculating systems (Mattilsynet, u.d.).

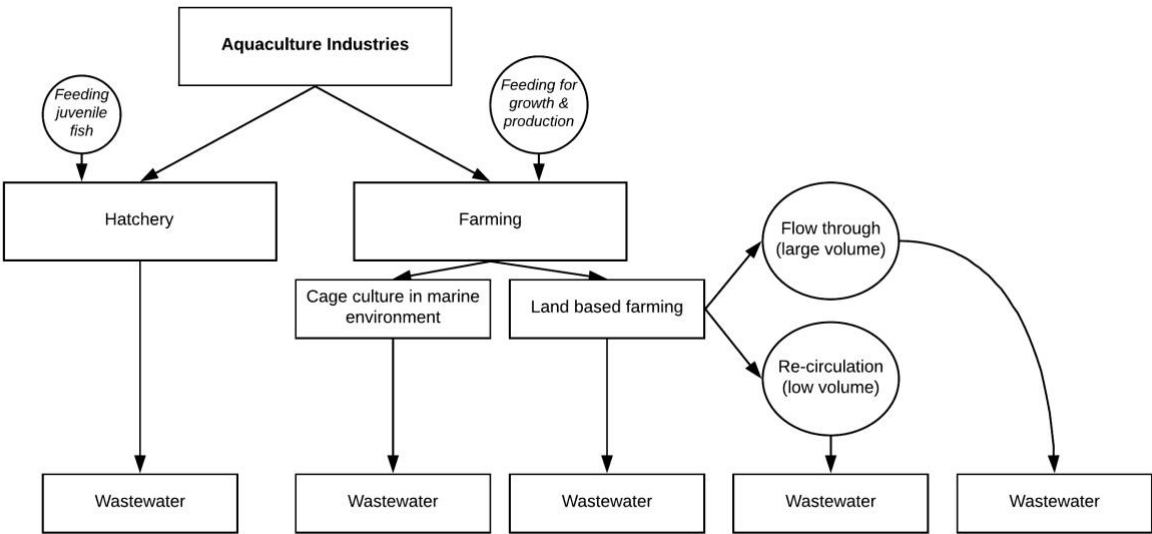

Figure 1 Wastewater production from aquaculture industries (Siddiqui, 2003)

Aquaculture waste mainly consist of feed waste and metabolic waste products, as feed must be consumed, digested and assimilated before it can be utilized (Board on Agriculture, National Research Council, 1993; Mugg et al., 1991). As feed pellets are supplied to the fish tanks in the different systems, it will either be consumed by fish or left to decompose. When consumed, by-products from fish metabolism comes in dissolved form or suspended form: dissolved waste includes BOD, COD, ammonia, nitrate and phosphorus, while suspended waste on the other

hand is directly generated from faeces, bacterial flocks and food particles (Couturier et al., 2009; Timmons and Ebeling, 2007; Chen, Coffin and Malone, 1997). In fish tank effluents, wastewater constituents include dissolved and particulate organic matter, TSS, nitrogen and phosphorus (Piedrahita, 2003). Waste generated in a Recirculating Aquaculture System (RAS) originates mainly from feed with particular matter (measured as TSS) as the main form of waste. The amount of TSS produced can thus be proportionally connected to the feeding rate and sludge production in a RAS can be estimated as the sum of TSS. Settleable solids in RAS will accumulate as sedimentation in storage tanks (APHA, 1999).

Sludge characteristics for the sludge used in this project were performed by one of the project participants, Aquateam (Table 1). The results were not published. The aquaculture sludge from Preline were collected in sludge tanks and consisted mainly of faeces and feed debris. A drum filter was used to filtrate the sludge from seawater, and the filter was washed with fresh water. The sludge was concentrated in a storage tank. The aquaculture sludge from Lerøy were of salt water origin and contained mainly feed debris and some faeces. The sludge was filtrated using a drum filter and pumped to an offshore container for concentration and storage.

*Table 1 Sludge characteristics determined by Aquateam for project purposes*

	<b>TS (%)</b>	<b>TVS (%)</b>	<b>Total N (g/kg)</b>	<b>Total P (g/kg)</b>
Aquaculture sludge, <i>Preline</i>	13.4	12.3	7.6	1.3
Aquaculture sludge, <i>Lerøy</i>	10.4	9.2	5.1	0.9
<i>Municipal sludge, Ivar</i>	2.1	1.8	1.6	0.4
<i>Municipal sludge, Bergen</i>	4.8	3.5	2.2	0.7

Gebauer and Eikebrokk, 2006, performed a characterization of fish farming sludge collected at a high feed-coefficient (1.38) from particle traps that were mounted on fresh water production tanks for Atlantic salmon smolts in a smolt hatchery (Table 2).

Table 2 Composition of Atlantic salmon smolt sludge (Gebauer and Eikebrokk, 2006)

Parameter	Range
TS (%)	6.3-12.3
VS (% of TS)	78.6-86.9
COD (g/l)	110-193
Total N (mg/l)	5450-10630
Total Phosphorus (mg/l)	1424-2780

A study of Norwegian waters' quality showed that smolt production utilizes surface waters as inlet sources, both lake water inlets and river water inlets, and this will result in large seasonal variations in water temperature (Kristensen et al., 2009). Fish are poikilothermic vertebras and their metabolic rate is thus a function of temperature. Feed intake and growth rate has been shown to increase when temperature is increased, and as waste production by fish can be determined as waste produced per unit of feed input, waste production will also increase as temperature increases (Matias del Campo et al., 2010; Koskela, Pirhonen, & Jobling, 1997). In a report produced by Nofima (Matias del Campo et al., 2010), a projection of sludge production in a RAS was made based on predictions of the capacity for fry and smolts during a period of ten years (Table 3). Trends of growth were estimated by the annual increase in biomass production capacity. The associated sludge production was shown from three production levels and the average production of 500 000 fish was used only as a minimum reference. A common production plan in RAS is 3-5 cycles to ensure production all year round.

Table 3 Estimation of produced dry sludge yearly in fish production (Matias del Campo, et al., 2010)

Fish weight (g)			Biomass (tons)			FCR* (kg of feed/kg of biomass)	Produced dry sludge (tons)		
Initial	Final	Gain	500 000 fish	1 000 000 fish	5 000 000 fish				
0	20	20	10	20	100	0.8	2.2	4.4	21.9
20	50	30	15	30	150	0.9	3.3	6.6	32.8
50	100	50	25	50	250	0.9	5.5	10.9	54.7
100	200	100	50	100	500	0.95	10.9	21.9	109.4
		Total	100	200	1000		21.9	43.8	218.8

\*FCR represents the Feed Conversion Rate

### 2.1.1 Fister Smolt as

Fister Smolt is a Norwegian smolt supplier localized in Hjelmeland. Their production is based on RAS: RAS system breed fish using indoor tanks at high densities in a controlled environment (Figure 2). Mechanical and biological filter systems are used to ensure purified water, removal of waste and feed remains, aeration of water currents and disinfection (Helfrich & Libey, 2013). The water currents provide oxygen for the fish, while also leading harmful waste out of the tanks. The water currents are supplied with oxygen and recycled back into the tanks after the process. The total amount of recycled water is expected to be at 95-99% (Aarhus et al., 2011). In the hydrocyclone, spinning water are lost to the sides of a cone by a centrifugal force. Here the velocity is slower, and solids are separated from the water and sink to the bottom (The University of Tennessee, Knoxville , u.d.). From the hydrocyclone, solids are further transferred to storage tanks where sedimentation occurs. Sludge samples can be obtained from these storage tanks.

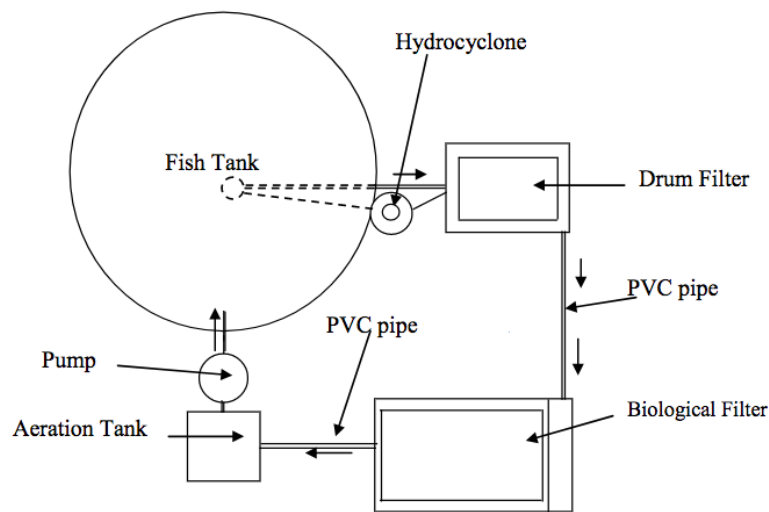

Figure 2 Sketch of recirculating aquaculture system (RAS) setup (Khater et al., 2011)

A considerable amount of sludge is produced using RAS. These solids are mainly composed of fish excretions and uneaten feed. The organic fraction (VS) can range from 50-92%. Fish sludge is typically characterized by a low total solid (TS) content when compared to other animal production wastes or to wastewater, however this might vary depending on fish type (Mirzoyan, Tal og Gross, 2010; Matias del Campo, et al., 2010). On behalf of Fister Smolt, Eurofins Agro-testing produced an analytical report based on a sludge sample from Fister Smolt (Table 4).



*Table 4 Characterization of sludge from Fister Smolt*

<b>Parameter</b>	<b>Value</b>	<b>Unit</b>
Dry matter	11.2	g/100g
pH	5.2	
Ammonium	0.5	kg/ton
Nitrogen	3.5	kg/ton
Sulphur	0.42	kg/ton
Phosphorus	4.1	kg/ton
Potassium	0.2	kg/ton
Magnesium	0.7	kg/ton
Calcium	11.5	kg/ton
Sodium	1.8	kg/ton
Copper	240	mg/kg TS
Zinc	580	mg/kg TS
Boron	30	mg/kg TS
Manganese	210	mg/kg TS
Iron	1600	mg/kg TS
Cadmium	1.0	mg/kg TS
Lead	3.7	mg/kg TS
Mercury	0.077	mg/kg TS
Nickel	28	mg/kg TS
Chromium	16	mg/kg TS

Feed provided in breeding systems contains several inorganic nutrients and energy sources (Table 5). These elements are essential for the growth, reproduction and health of the fish. By making nutrient recycling an element of the biogas production process, one could have a sustainable solution that will close the resource cycle.

*Table 5 Biological function of some essential inorganic nutrients in fish feed (Food and Agriculture Organization of the United Nations u.d.)*

<b>Macroelement</b>	<b>Biological function</b>
Calcium	Essential component of bone, cartilage and skeleton. Key role in cell membrane permeability.
Phosphorus	Essential component of bone, cartilage and skeleton. Essential component of phospholipids, nucleic acids and ATP. Key role in cell metabolism.
Magnesium	Essential component of bone, cartilage and skeleton. Stimulates muscle and nerve contraction.
Sulphur	Essential component of key amino acids, vitamins, the insulin hormone and the skeleton.
<b>Microelement</b>	<b>Biological function</b>
Iron	Essential component of haemoglobin and myoglobin. Essential for oxygen and electron transport.
Zinc	Essential component of enzymes and cofactor in enzyme systems. Key role in metabolism of lipids, proteins and carbohydrates.
Manganese	Enzyme activator and essential component of pyruvate carboxylase. Essential for bone formation and the reproductive cycle.
Copper	Essential component of enzyme systems. Involved in iron metabolism and haemoglobin synthesis.

## 2.2 Microorganism growth and process parameters in anaerobic systems

Most microorganisms, including methanogens, reproduce asexually by binary fission. In this process, a single cell can divide itself physically into two new genetically identical cells. If these bacteria were to grow without removal or any other outside involvement, they would follow the exponential growth pattern (Vaccari, Strom, & Alleman, 2006).

Anaerobic microbial systems can be divided into two specific categories: batch systems or continuous systems. A batch system is one in which all nutrients are present at the start and there is no deliberate inflow or outflow. This system involves the transfer of substrate into a reactor filled with only inoculum and will thus involve new conditions for the substrate organisms. This process is referred to as the lag phase and defines the time before the organisms become adapted to the new environment and optimal growth conditions are established. Once the organisms have adapted they will grow exponentially: substrate and nutrients are in excess, and no potentially inhibitory products have accumulated yet. However, exponential growth cannot endure for a long period of time in a batch system, as depletion of substrates and/or build-up of inhibitory products will cause decreasing or stationary growth, and thus will most of the microorganisms in this system not be growing at their maximum growth rate (Vaccari, Strom, & Alleman, 2006).

A continuous system on the other hand, has both inflow and outflow during the system running time: it receives inputs of substrate at a specific rate, as well as it loses substrate at a specific rate to ensure that the total volume is constant. It is of great interest to recognize any reactions that might occur inside the bioreactor, and to keep track of inputs and outputs. This can be organized in means of a mass balance equation (Vaccari, Strom, & Alleman, 2006). The bioreactor (chemostat) in the system will need to have continuous stirring or mixing, to ensure a homogenous environment. Once the reactor is inoculated with microorganisms that will utilize the substrate for growth, the system can move towards a stable steady state condition. In the steady state condition, the net growth is equal to the dilution rate: when the microorganism growth rate increases the substrate concentration will naturally decrease, which in turn slows down the growth. When the growth is too slow, the microorganism will leave the system at a faster rate than the growth rate, and such the substrate concentration will increase. This increase in substrate concentration will again lead to an increased growth rate (Vaccari, Strom, & Alleman, 2006). Solid retention time (SRT) is related to the growth rate of the biomass, and in a microbial population the minimum applied SRT is inversely proportional to the maximum rate of growth. To prevent a washout of methanogenic organisms the STR must be maintained

at a higher number than the minimum SRT (Wold, 2017). In full scale reactors, a maximization of biogas production can be achieved by increasing the organic loading rate. Even though higher organic loading rates will allow for higher kinetic rates, an overload of substrate might also unbalance kinetic rates in the AD reaction steps (Figure 4). Substrate overloading might cause an accumulation of VFA, which in a case of low buffer capacity in the system can cause a drop in the pH. The drop in pH can lead to inhibition of methanogenic microorganisms and thus cause further accumulation of VFA (Polizzi, Alatrisme-Mondragon, & Munz, 2018).

For methanogens, the optimum temperature for growth lies around 35 °C but methanogenesis can occur at temperatures far lower and far higher than this (Wiese & Kvenvolden, 1992) (Zeikus & Winfrey, 1976). Methanogens prefer a narrow pH range between 6 and 8, but the organisms are also known to occur at pH ranges far lower and far higher than this (Wiese & Kvenvolden, 1992). The pH will affect the form (charge), availability and toxicity of organic and inorganic substrates such as ammonia and ammonium ions ( $\text{NH}_3/\text{NH}_4^+$ ) and hydrogen sulfide and bisulfide ( $\text{H}_2\text{S}/\text{HS}^-$ ). The role of ammonia in anaerobic digesters is multiple; ammonia and ammonium will at an optimal level ensure a nutrient supply of nitrogen for anaerobic biomass in addition to increasing the buffer capacity of the system and thus counteract the acidification caused by production of VFAs (Vaccari, Strom, & Alleman, 2006; Polizzi, Alatrisme-Mondragon, & Munz, 2018). However, an ammonia and ammonium concentration exceeding a certain threshold might act as inhibitory agents to the system. Total ammonia nitrogen (TAN) in an aqueous systems accounts for the unionized free ammonia (FA),  $\text{NH}_3$ , and  $\text{NH}_4^+$ . The equilibrium of FA is governed by pH and temperature (Equation 1) (Polizzi, Alatrisme-Mondragon, & Munz, 2018).

$$FA = TAN \left( 1 + \frac{10^{-pH}}{10^{-(0.09018 + \frac{272.92}{T})}} \right)^{-1}$$

*Equation 1 Equilibrium of total ammonia nitrogen, governed by pH and temperature*

The main inhibitory mechanisms of FA include direct inhibition on the methanogenic biomass enzyme production and passive diffusion effects when FA cross cellular membranes into bacterial cells and interfere with cell pH. This can lead to unbalance of protons and an increase in energy requirements. Still, these effects will depend on the methanogenic biomass

physiology (Polizzi, Alatrisme-Mondragon, & Munz, 2018). In several studies, ammonia inhibition is recognized as one of the prime causes of system failure in AD, however the toxic threshold of ammonia concentrations are widely varied in current reports possibly due to different substrate characteristics, inoculums, temperatures and pH values. Gallert, Bauer, & Winter, 1998, accentuates the lack of distinction between levels of FA and TAN, which probably increases the varying concentration range even further.

An inhibited steady state is the consequence of ammonia inhibition that has been reported most frequently prior to complete failure of the AD system. An inhibited steady state can be characterized by a stable process at a lower methane production that results from interaction between FA, VFA and pH effects. To prevent or control the inhibition by ammonia, co-digestion has been presented as a successful solution because it allows for carbon/nitrogen optimization and dilution of inhibitory compounds (Polizzi, Alatrisme-Mondragon, & Munz, 2018).

The digester performance relies on a proper control of pH, and sufficient alkalinity in the digesters can serve as a buffer that prevents a rapid pH change. As VFA are produced and accumulated, the pH of the system will initially decrease. An increasing concentration of VFA will lead to an unstable system. However, when VFAs are consumed by methanogenic bacteria alkalinity is produced and the pH will increase, and the process stabilizes (Gerardi, 2003). A pH of between 6.8 and 7.2 is reached in the reactor when VFAs are converted to methane and carbon dioxide. The alkalinity of the system is present as bicarbonates in equilibrium with carbon dioxide in the biogas at a specific pH. Carbon dioxide is released when organic compounds are degraded, similarly are carbon dioxide and ammonia released when amino acids and proteins are degraded (Gerardi, 2003). Release of carbon dioxide produces carbonic acid, bicarbonate (alkalinity) and carbonate (Equation 2). The carbon dioxide content of the biogas will significantly affect the pH of the system, as it dissociates into bicarbonates, carbonates and hydrogen ions.

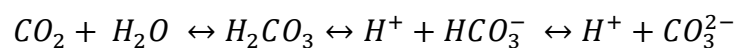

*Equation 2 Production of carbonic acid, bicarbonate and carbonate from the release of carbon dioxide in water*

Release of ammonia from degradation of organic compounds produces ammonium (Equation 3) (Gerardi, 2003).

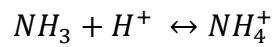

*Equation 3 Equilibrium between ammonia and ammonium*

The pH of the system affects the degree of which ammonium is formed from ammonia (Figure 3) (Kunz & Mukhtar, 2016).

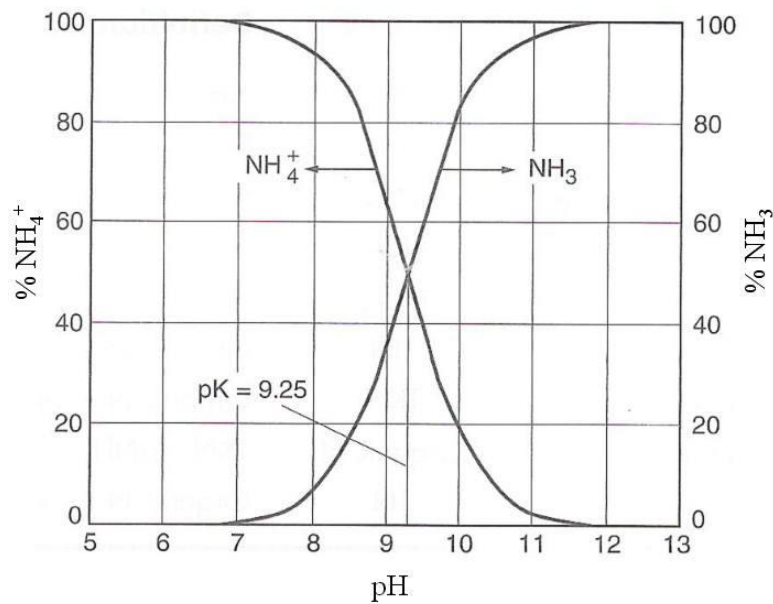

*Figure 3 Distribution of ammonia and ammonium as a function of pH (Kunz & Mukhtar, 2016)*

At a low pH (high concentration of hydrogen ions) more ammonia is converted to ammonium, while when the pH is higher (low concentration of hydrogen ions) ammonia is generated when the hydroxide ion removes a proton from the ammonium ion (Equation 4) (Gerardi, 2003).

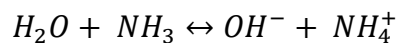

*Equation 4 Equilibrium between ammonia and ammonium ions in water*

The ammonia also dissolves in water together with carbon dioxide and form ammonium ions and bicarbonate (Equation 5), (Gerardi, 2003).

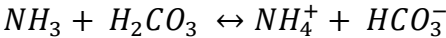

Equation 5 Production of ammonium and bicarbonate from the release of ammonia and carbon dioxide in water

### 2.3 Anaerobic digestion overview

Anaerobic digestion (AD) is the stabilisation and degradation of organic materials. Anaerobic processes are microbial processes that take place in the absence of oxygen, and in which organic raw material is converted to biogas. AD is a common technology for the treatment of wastewater, slurries, sludges, digestion of organic municipal solid waste and for production of renewable energy (Wellinger, Murphy, & Baxter, 2013). The coordinated activity of four different trophic groups ensures the process stability during AD (Figure 4):

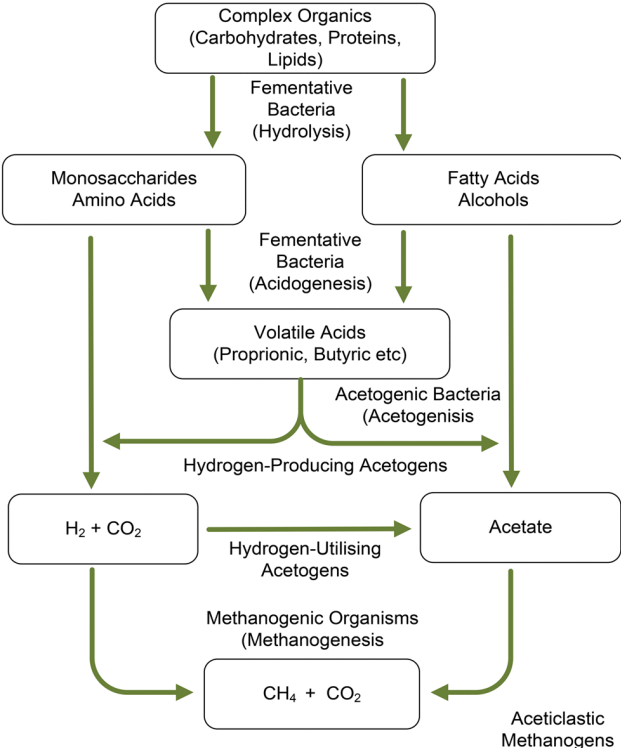

Figure 4 Metabolic pathways and microbial groups (Gueterbock & Sangosanya, u.d.)

The first step of the AD process is hydrolysis. The anaerobic acidogenic bacteria group consists of hydrolytic bacteria that breaks down large macromolecular organic compound

(polymers) into monomers by producing extracellular enzymes. The hydrolysis is considered to be the rate-limiting step for a stable anaerobic digestion process (Wold, 2017; Vaccari, Strom og Alleman, 2006).

The monomers from the hydrolysis are subsequently fermented in acidogenesis, the second step of the AD process, to VFA, carbon dioxide and hydrogen. The VFAs are converted to acetate and hydrogen by acetogenic bacteria. Acidogenesis is the fastest step in the AD process, while the acetogenic bacteria on the other hand are slower growing and might also be inhibited by hydrogen (Wold, 2017; Vaccari, Strom og Alleman, 2006).

The last step of the sequence is the methanogenesis, where methane is produced. Methanogens have a low growth rate on acetate and is thus a limiting factor in. Methanogenesis converts the acetate and hydrogen from the earlier steps into gaseous end products. These end products include reduced methane and oxidized carbon dioxide. Methanogens rely on three options for available substrate forms (Figure 5). Option 1, the dominant option, is where carbon dioxide serves as an acceptor for donated electrons from hydrogen, carbon monoxide or formate. Option 2 includes the genres *Methanosarcina* and *Methanotherix* and use acetate that serves as both electron acceptor and donor, in a metabolic acetoclastis process. Option 3 is similar to option 2 as it uses substrates such as methanol or amines that serves as both electron acceptors and donors, however, option 3 includes several methanogen genres and hydrogen gas can also be used as a source of reduction (Wold, 2017; Vaccari, Strom og Alleman, 2006).

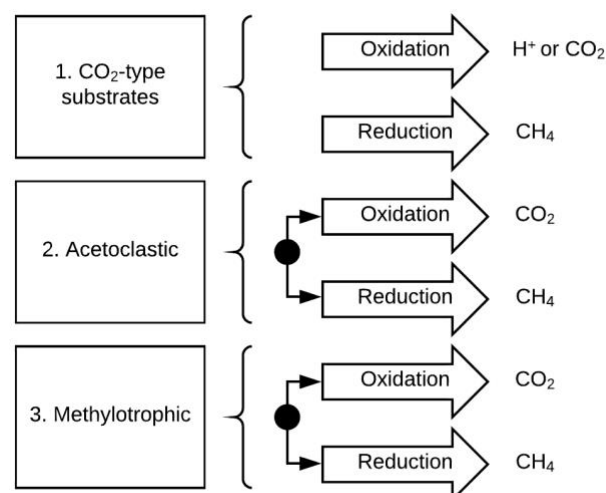

Figure 5 Substrate options for the methanogenesis step of anaerobic digestion (Vaccari, Strom, & Alleman, 2006)



## 2.4 Anaerobic digestion of aquaculture sludge

Several investigations of anaerobic treatment of aqua culture sludge has been conducted. Kugelman og Van Gorder, 1991, used CSTRs to study the treatment of freshwater concentrated sludge (4-6% TS) and diluted sludge (2-3% TS) at 35 °C. The study found that the AD process with concentrated sludge was strongly inhibited by ammonia and had high VFA concentrations. The methane yields corresponded only to 35-47% of the theoretical methane yield. Based on these observations, the authors suggested a CSTR system with diluted wastewater under mesophilic conditions for aquaculture sludge digestion. The diluted wastewater was suggested as a way to overcome inhibition by free ammonia.

In a study conducted by Lanari and Franci, 1998, an upflow cylindrical digester was used to digest freshwater sludge from a RAS. The sludge was generated at different feeding rates with an average TS of 1.4-2.4%, and digested anaerobically at 25 °C with a 22-28-day hydraulic retention time (HRT). A >90% digestion of TS, TSS and VS was observed, and a high degree of organic matter stabilization was concluded. In addition to this, high quantities of biogas were achieved with >80% methane produced in the reactor. A zeolite column in the treatment system removed the effluent of nitrogen. There was no observed inhibition of the process nor the system.

Gebauer and Eikebrokk, 2006, investigated the anaerobic treatment of concentrated sludge (6.3-12.3% TS) collected from storage tanks in a salmon smolt hatchery. The sludge was treated in semi-continuous stirred tank reactors at 35 °C, with a 55-60-day SRT. The process was strongly inhibited by free ammonia. In addition, high long chain fatty acids and VFA concentrations were observed and also indicated a strong inhibition of the process. However, the digested sludge had a high enough alkalinity and avoided process failure due to acidification of the contents of the reactor. The buffer capacity kept the pH value at 7.4-7.55 during 155 operation days. The study also found that aquaculture waste from a full-scale smolt hatchery, 1 000 000 smolts, could be treated in a continuously operating anaerobic treatment plant, and by burning the produced biogas one could achieve a returning net energy production of 43-47 MW h/year (2-4% of energy demand in a hatchery with flow through system).

Mirzoyan, et al., 2008 investigated sludge digestion and methane production in three Upflow Anaerobic Sludge Blanket Digestion (UASB) reactors over four months. 400 ml of fresh brackish aquaculture sludge was introduced daily, with an average retention time of 15 days.

Produced biogas were volumetrically collected and methane content was analysed by gas chromatography. A reduction in sludge mass from 35 to 70% was observed. An average of 70ml of biogas was produced daily (40%), 0.021 g COD, was achieved. No inhibitory compounds such as nitrites, nitrates or sulphides were observed.

In their review *Anaerobic digestion of sludge from intensive recirculating aquaculture systems: Review*, Mirzoyan, Tal, & Gross, 2010, stressed that RAS produce high volumes of biosolid waste that can be a source of pollution if it is not treated properly. They concluded that anaerobic digestion results in stabilization of sludge, sludge-mass reduction, biogas production and a possible source for water and energy savings in a RAS. A summary of current reports and research on anaerobic digestion of sludge produced in RAS were presented (Table 6).

Based on the literature review, future perspectives might also include investigating the possible energy recovery from anaerobic digestion of aquaculture waste.

Table 6 Operational conditions and sludge digestion efficiency of anaerobic digestion systems of sludge from RAS (Mirzoyan, Tal, & Gross, 2010)

Authors	Fish culture	Digester type	Digestion efficiency (% TS)	Digestion efficiency (% VS)	Digestion efficiency (% COD)	Biogas (%)	Methane production (1CODg <sup>-1</sup> added)	Inhibition
Kugelman & Van Gorder, 1991	Atlantic salmon (Fresh water)	Batch fill and draw reactors	-	-	34-47 (Undiluted) 57-71 (Diluted)	36-71	0.125-0.164	NH <sub>3</sub>
Lanari & Franci, 1998	Rainbow trout (Fresh water)	Upflow cylindrical digester	92	93-97	-	>80	0.198-0-250	No
Gebauer, 2004	Salmon (Brackish water)	CSTR	-	47-62	37-55 (Undiluted) 60 (Diluted)	49-58	0.114-0.184	Na
Gebauer & Eikebrokk, 2006	Salmon smolt (Brackish water)	CSTR	-	74-79	45-53	59-61	0.14-0.151	NH <sub>3</sub> , long-chain fatty acids
Mirzoyan, et al., 2008	Prawn (Brackish water)	UASB	-	-	-	30-60	0.02	No
Mirzoyan N., 2009	Striped bass (Brackish water)	UASB	-	92-98	99.6	4-53	0.04-3.6	No
Tal, et al., 2009	Seabream (Brackish water)	UASB	80	-	-	60	-	No
Sharrer, Tal, Ferrier, Hankins, & Summerfelt, 2007	Rainbow trout (Brackish water)	Membrane bioreactor	99.7-100	>99.8	-	-	-	No

### 3. Objectives and scope of work

The main objectives of this study were to evaluate the biogas production potential and the process stability when co-digesting aquaculture and municipal waste. There is a knowledge gap in the current understanding of this process, and this study aimed to investigate this by the use of a batch system and a CSTR system (Referred to as a daily fed stirred tank reactor, DFSTR, in this thesis). In the experiments, aquaculture waste from Fister Smolt and municipal waste from IVAR SNJ was analysed.

Substrate characteristics were performed prior to the experiments. Parameters measured included pH, alkalinity, TS, TVS, COD, nitrogen and phosphorus. As these parameters were measured on both the influent and the effluent, a mass balance could be set up to give an overview the system. Such calculations can be used in error analysis, and to evaluate the faith of the substrate contents. As the substrates in this study were of fresh water origins, the effect of high salinity and sulphate was not measured or evaluated. Neither was elements such as calcium and magnesium, in relation to calcium carbonate formation and struvite precipitation. These are both aspects for further research.

An aim for this study was to investigate co-digestion of aquaculture sludge from Fister Smolt and the municipal waste from IVAR SNJ, and the initial batch test 1.0 was based on the results of Aquateam COWI (project participant): In April 2017 Aquateam COWI reported an increase in methane production of 46% when 25% (volume) aquaculture sludge (*Preline*) was co-digested with municipal waste (*Bergen*) using a batch test system. Further, in June 2017, they observed a 12% increase in methane production when 10% (volume) aquaculture sludge (*Lerøy*) was co-digested with municipal waste (*Bergen*) using a batch test system. However, in June 2017 co-digestion of aquaculture sludge (*Preline*) with municipal waste (*IVAR Grødaland*) using a batch test system, did not show an increase in methane production.

Batch system tests were performed in this study to determine the biogas production potential and methane yield of the substrates, using the AMPTS II. In the batch system, biogas potential and methane yield for aquaculture waste, municipal waste, active sludge, mixes of aquaculture waste and municipal waste and mixes of aquaculture waste and active sludge were determined. Methane yields were calculated based on the COD load. The substrates were treated with COD

loads of 1 g and 2 g while the mixes had defined, but varying, COD loads. As the 25% addition of aquaculture sludge achieved the most positive results in the Aquateam COWI tests, the same ratio was chosen for the co-digestion processes in this study, in addition to a 50/50 COD ratio mix.

Potential restraints were identified in the literature review: nitrogenous compounds can serve as inhibitory agents to anaerobic processes and lead to process failure during anaerobic digestion of aquaculture waste. In order to evaluate the process stability as well as the biogas production, a semi-continuous test system was used. Further, the DFSR system could also be used as a reference and control to the findings in the batch test. In the DFSTR system, four reactors were set up with varying substrate compositions (Table 9). Reactor 1 was fed only municipal waste and was expected to behave as a positive control that would produce methane at a stable rate with no to little inhibition. Reactor 2 was fed aquaculture waste as the only substrate and based on the literature review this reactor was expected to encounter problems and possibly also undergo a complete system failure. The high level of nitrogen was anticipated to be a limiting factor as the ammonia might inhibit the methanogenic processes. In addition to this, increased alkalinity as a result of accumulation of ammonia could lead to an unstable operational process. To overcome these possible problems reactor 3 was fed 25% aquaculture waste and 75% municipal waste. Aquaculture waste has a high nitrogen content while municipal waste tends to have a low nitrogen content. Thus, these substrates could prove to function well in co-digestion. In addition, reactor 4 was fed aquaculture waste as the only substrate but the pH was adjusted to maintain neutral by adding hydrochloric acid (HCl). As a result, the nitrogen would primarily be present as ammonium, which are less inhibiting to the process. The process stability and of reactor 4 was therefore expected to exceed that of reactor 2.

This study did not focus on recycling of nutrients from the waste products of the anaerobic process, such as nitrogen and phosphorus. The potential use of liquid and solid digestion effluents as a fertilizer could be an aspect for further research.

## 4. Materials and methods

Aquaculture waste from Fister Smolt, and primary sludge (municipal waste), inoculum and waste activated sludge (referred to as activated sludge) from IVAR SNJ, was analysed and utilized in the experiments presented in this study. The aquaculture waste was collected immediately after the hydrocyclone step. The primary sludge was collected from the bioreactor feeding tank. The activated sludge was collected directly after the thickening from the anaerobic process. In the tables and graphs in the following sections, the aquaculture waste samples will be indicated with “F”, the primary sludge samples will be indicated with “K” and the activated sludge samples will be indicated with “AS”.

### 4.1 The Automatic Methane Potential Test System (AMPTS) II

A biochemical methane potential (BMP) test provides an indication of the biodegradability of a specific substrate, and of the methane production potential via anaerobic digestion of that substrate. The AMPTS II instrument, developed by Bioprocess Control, provides a laboratory scale online measurement of biogas produced from the anaerobic digestion of a biological degradable substrate (Bioprocess control, u.d.). The setup of the instrument (Figure 6) includes the Sample Incubation Unit (unit A), the CO<sub>2</sub>-absorbing Unit (unit B) and the Gas Volume Measuring Device (unit C). The bioreactors in unit A were 500ml glass bottles with a stopper with two tubing ports, with one tube connected to unit B, and a rotating shaft. Up to 15 bioreactors containing anaerobic inoculum and substrate sample can be incubated at a specific temperature in a thermostatic water bath. The contents are mixed by slow rotating motors connected to the rotating shafts. In unit B, biogas that have been produced in the bioreactors will pass through an individual glass container filled with an alkaline solution, such as NaOH. This solution will retain gas fractions such as carbon dioxide and allow biogas to pass through to unit C. In unit C, the biogas released from unit B is measured by means of a wet gas flow measuring device with a multi-flow cell arrangement. When a defined volume of gas flows through the device, a digital pulse is generated. An integrated software system is used for

recording of the results. The software system is also used to display and analyse the results (Bioprocess control, u.d.).

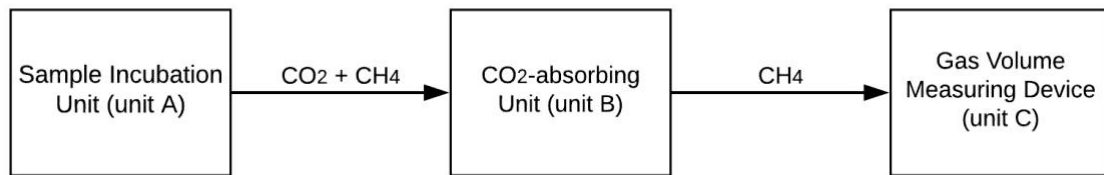

Figure 6 Sketch of the Automatic Methane Potential Test System (AMPTS II) setup

In an anaerobic reactor inlet COD transformed into gaseous COD can be measurement of methane production: 1 kg of COD can theoretically be converted to 0,35 m<sup>3</sup> methane at standard conditions (Equation 6) (Henze et al., 2008; Rakotonomenjanahary, 2017)

$$V_{CH_4} = \frac{22,4 \frac{l CH_4}{mole CH_4}}{64 \frac{g COD}{mole CH_4}} = 0,35 \frac{l CH_4}{g COD}$$

Equation 6 Theoretical methane production

Expected methane production values (volume) was calculated using the universal gas law (Equation 7). In the equation, V is defined as volume occupied by the gas in liter, n is the moles of gas, R is the constant 0.082057 atm.L/mole.K, T is the temperature (kelvin) and P is the pressure (atm).

$$V = \frac{nRT}{P}$$

Equation 7 Universal gas law

## 4.2 Anaerobic batch tests

Batch tests were conducted using the AMPTS II instrument to test the biodegradability and methane potential of the aquaculture waste from Fister Smolt and the primary sludge from IVAR, SNJ. Two days before the batch test start up, a start medium containing 400ml inoculum and 0,046 ml acetic acid (HAc) was introduced to all the 14 bioreactors. The inoculum was added to prepare an optimal growth medium for the substrate in the batch test. HAc (Sigma-Aldrich) was added as control, as this acid is biodegradable and expected to be fully oxidized.

COD entering an anaerobic reactor will either be chemically digestible organics that leaves the reactor as methane gas and can be used as a measurement of the biodegradability of the substrates, or undegradable solids that will leave the reactor as liquid effluent (Figure 7) (Henze et al., 2008).

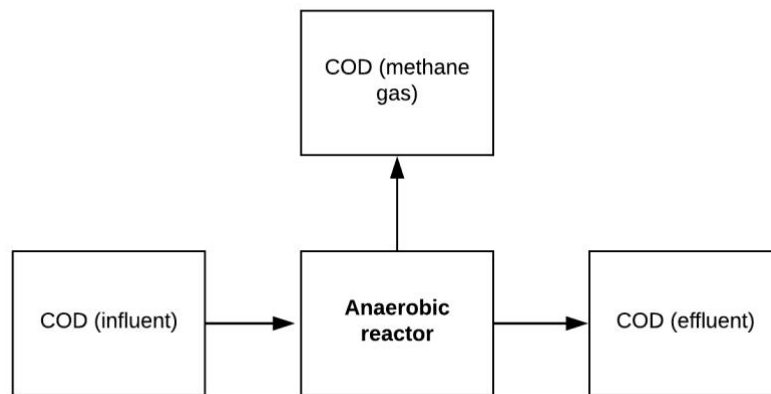

Figure 7 Faith of COD influent in an anaerobic reactor (Henze et al., 2008)

The substrates were analysed by means of COD: the initial 1.0 batch test setup (Table 7) included reactors with duplicates of control/reference samples (blank), aquaculture waste samples of different COD loads and primary sludge samples of different COD loads. Two reactors (12 and 13) were set up as duplicates of a 50% COD/COD mix, while two other reactors (14 and 15) were set up as duplicates of a mix of 25% aquaculture waste and 75% primary sludge.

Table 7 Setup of batch test 1.0

Reactor	Name	Conditions
1	Blank	20 ml inoculum
2	Blank	20 ml inoculum
3	F 1 g COD	14.3 g aquaculture waste + 20 ml inoculum
4	F 1 g COD	14.3 g aquaculture waste + 20 ml inoculum
5	F 2 g COD	28.6 g aquaculture waste + 20 ml inoculum
7	F 2 g COD	28.6 g aquaculture waste + 20 ml inoculum
8	K 1 g COD	33.4 g primary sludge + 20 ml inoculum
9	K 1 g COD	33.4 g primary sludge + 20 ml inoculum
10	K 2 g COD	66.7 g primary sludge + 20 ml inoculum
11	K 2 g COD	66.7 g primary sludge + 20 ml inoculum



12	F+K 2 g COD	14.3 g aquaculture waste + 33.4 g primary sludge + 20 ml inoculum
13	F+K 2 g COD	14.3 g aquaculture waste + 33.4 g primary sludge + 20 ml inoculum
14	F+K 2,7 g COD	16.7 g aquaculture waste + 50.0 g primary sludge + 20 ml inoculum
15	F+K 2,7 g COD	16.7 g aquaculture waste + 50.0 g primary sludge + 20 ml inoculum

The temperature of the water bath for incubation of the batch tests was set to 35 °C. The CO<sub>2</sub>-absorbing unit (unit B) was prepared using 3M NaOH (Sigma-Aldrich) and 0,4% Thymolphthalein pH indicator solution (Sigma-Aldrich). The biogas produced was measured by the AMPTS II and the results were presented and stored online by the software system. The test was terminated when the methane production entered a stationary phase.

Batch test 2.0 was run based on the principles and methods described for batch test 1.0, however different samples and sample concentrations were analysed (Table 8). The test was terminated when the methane production was less than 5Nml/day.

*Table 8 Setup of batch test 2.0*

<b>Reactor</b>	<b>Name</b>	<b>Conditions</b>
1	Blank	20 ml inoculum
2	Blank	20 ml inoculum
3	F 2 g COD	29.4 g aquaculture waste + 20 ml inoculum
4	F 2 g COD	29.4 g aquaculture waste + 20 ml inoculum
10	AS 2 g COD	37.6 g activated sludge + 20 ml inoculum
11	AS 2 g COD	37.6 g activated sludge + 20 ml inoculum
12	F+AS 2 g COD	14.8 g aquaculture waste + 18.8 g activated sludge + 20 ml inoculum
14	F+AS 2 g COD	14.8 g aquaculture waste + 18.8 g activated sludge + 20 ml inoculum

### 4.3 Daily fed stirred tank reactors

An anaerobic DFSTR system was set up using the AMPTS II instrument to test the methane production process stability of the aquaculture waste from Fister Smolt and the primary sludge from IVAR, SNJ. The bioreactors were four 1000 ml bottles with two side ports (Figure 8). The ports were fitted with Tygon laboratory tubes for sludge feeding (inlet) and sludge withdrawal (outlet). The laboratory tubes had fitted plastic tubing clamps for opening and closing. Each bioreactor had a stopper with two tubing ports, with one tube connected to unit B, and a rotating shaft for continuous sample mixing.

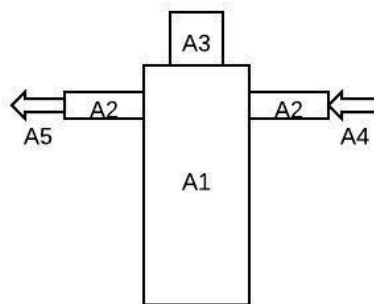

Figure 8 Daily fed stirred tank reactor A1: Bioreactor, A2: Side ports, A3: Stopper with tube connection to unit B, A4: Feeding inlet (with clamp), A5: Sludge outlet (with clamp)

The bioreactors were incubated with 750 ml of inoculum for 10 days. During this time, primary sludge was fed to all four reactors. The 10-day start up period was performed as a control to detect system faults such as gas leaking, reactor performance and inoculum quality.

The inoculum had a pH of 7.38 when the different substrates (Table 9) were introduced to the bioreactors. The stopper tube connected to unit B was closed using a plastic clamp to stop the pressured gas from entering during the feeding process. The bioreactors were fed daily with a 100 ml plastic syringe through the feeding inlet. 50 ml of sample was injected and 50 ml of sample was withdrawn. A volumetric cylinder was used to collect the sludge effluent from the outlet tube. Care was taken to maintain a stable liquid volume, and at times when the total volume exceeded 750 ml, a necessary sample volume was extracted and added to the daily produced methane log. In CSTR, the HRT is equal to the SRT and is thus referred to as SRT in this study (Wold, 2017). The DFSTR was operated at a 15-day SRT. Conductivity and pH were measured daily on the effluent samples. VFA, nitrogen, phosphorus, total COD and carbon dioxide analyses were conducted several times during the DFSTR running time. The biogas

produced was measured by the AMPTS II and the results were presented and stored online by the software system.

*Table 9 Setup of the DFSTR system*

Reactor name	Substrate	Daily organic load	
		g COD/d	g COD/l/d
1	Primary sludge	1.5	2.0
2	Aquaculture sludge	3.4	4.5
3	75% primary s + 25% aquaculture waste	2.0	2.6
4	Aquaculture waste (pH adjusted*)	3.4	4.5

\* 4.4 g CaCO<sub>3</sub> removed (0.01M HCl). Ammonia IC<sub>50</sub> = 25 mg N/l (30.6 mg/L NH<sub>3</sub>)

#### 4.4 Analytical methods

In order to characterize sludge before (the inlet sludge), during and after (the outlet sludge) the experiments, several analytical methods were performed. In some of the measurements, the sludge samples were diluted so that the end concentrations would fit the concentration ranges of the test kits. The end concentrations were pre-calculated based on the established sludge characterisations. For measurement of dissolved sludge, filtration was initially used to prepare the samples. However, clogging of filter and poor quality of prepared sample was observed. For dissolved sample analysis centrifugation at 10000 RCF for 10 minutes provided a clear supernatant and gave valid parallels.

##### 4.4.1 pH and conductivity measurements

Measurements of pH and conductivity were conducted in the laboratory using a WTW Multi 340i. pH was measured using a SenTix 41 pH-Electrode. The pH was measured directly after sample collection. Conductivity was measured using a TetraCon 325 Conductivity Cell. The conductivity was measured directly after sample collection.

##### 4.4.2 Total solids and total volatile solids measurements

This measurement method was conducted based on the standard method for characterization of wastewater (SM 2540 B, C and E) (Clesceri, Greenberg, & Eaton, 1998). Evaporating dishes

for three parallels of each sludge were pre-combusted and cooled in a desiccator. Gloves was used, and care was taken to avoid touching the dishes. The tara weight of each dish was weighed on an analytical balance and noted as  $m_{dish}$ . Homogenised sludge was transferred to the dishes and the exact volume was noted as  $V_{sample}$ . The dishes were then placed in a Termaks 9000 laboratory drying oven at 105 °C for 24 hours. After this, the dishes were cooled in a Sicco Star-Vitrum desiccator with borosilicate glass to room temperature. The dishes and residual were weighed on an analytical balance, and the weight was noted as  $m_{dish+residual}$ . The dishes were placed back in the desiccator for 15 minutes and the measurement was repeated to ensure a stable and constant weight. TS of the sample was calculated (Equation 8).

$$TS \left[ \frac{mg}{l} \right] = \frac{m_{dish+residual} - m_{dish}}{V_{sample}}$$

*Equation 8 Calculation of TS*

After this step, the dishes were combusted for 30 minutes in a Nabertherm muffle oven. The dishes were then cooled for a short time in air before they were transferred to de desiccator until the temperature had cooled to room temperature. The dishes and ignited residual were weighed on an analytical balance, and the weight was noted as  $m_{dish+ignited\ residual}$ . The dishes were placed back in the desiccator for 15 minutes and the measurement was repeated to ensure a stable and constant weight. TVS of the sample was calculated (Equation 9).

$$TVS \left[ \frac{mg}{l} \right] = TS - \frac{m_{dish+ignited\ residual} - m_{dish}}{V_{sample}}$$

*Equation 9 Calculation of TVS*

#### 4.4.3 Total COD measurements

COD test kits from Merck Spectroquant were used to perform COD measurements on the sludge samples in this study. Two different measuring ranges were used: 100-1500 mg/l and 500-10000 mg/l. The COD expresses the amount of oxygen from potassium dichromate that will react with 1l of water containing oxidizable substances, under specific conditions. 1 mole potassium dichromate is equivalent to 1.5 mole oxygen. The diluted sludge sample is oxidized with a sulfuric solution of potassium dichromate. Silver sulphate is used as catalyist. Chromium,

in the form of  $\text{Cr}^{3+}$  ions, can be determined photometrically (*further information can be found in the Merck Spectroquant instruction manual*).

As described in the Merck Spectroquant instruction manual, 1-2 ml (depending on the concentration range of the kit) diluted sludge sample were pipetted into the reaction cell. The contents of the cell were vigorously mixed. The prepared cell was then heated at 148 °C for 120 minutes in a Merck TR 620 thermoreactor. After 10 minutes of cooling, the mg/l COD was determined using a Merck Spectroquant Pharo 300 spectrophotometer.

#### 4.4.4 Volatile fatty acids and alkalinity measurements

A manual titration set-up was used in this study. The VFA analysis followed the 5-point titration procedure (Lahav & Loewenthal, 2000). 15 ml sample was centrifuged using a Thermo Fisher Heraus Sepatech Biofuge 17RS centrifuge. 10 ml of the centrifuged sample were diluted to 50 ml using deionized water and placed on a magnetic stirrer. The rotation was set to a low phase to minimise the input or loss of carbon dioxide. Conductivity and temperature measurements were conducted (4.4.1). The initial pH was recorded. 0.05M and 0.1M hydrochloric acid (Sigma-Aldrich) were prepared and used as titrant. The titrant was added through a 50 ml glass burette. Volume of acid added were read at pH values at approximately 6.7, 5.9, 5.2 and 4.3. The actual volume and pH value was noted.  $\text{CaCO}_3$  (alkalinity) and VFA concentrations were calculated using the computer program TITRA 5.

#### 4.4.5 Orthophosphate and total phosphorus measurements

Phosphate test kits from Merck Spectroquant were used to perform orthophosphate and total phosphorus measurements on the sludge samples in this study. A measuring range of 0.05-5.00 mg/l  $\text{PO}_4\text{-P}$  were used. Orthophosphate ions in a sulphuric solution will react with molybdate ions to form molybdophosphoric acid. The ascorbic acid in the cell will reduce this to phosphomolybdenum blue that can be determined photometrically. As this test only measures orthophosphate, the sludge samples must be decomposed by digestion before one can measure the total phosphorus concentration (*further information can be found in the Merck Spectroquant instruction manual*).

As described in the Merck Spectroquant instruction manual, digestion for the determination of total phosphorus is done by pipetting 5ml of diluted sludge sample into a reaction cell and

adding 1 dose of the included reagent P-1K. The reaction cell was then heated at 120 °C for 30 minutes in a Merck TR 620 thermoreactor. After cooling to room temperature, 5 drops of reagent P-2K and 1 dose of reagent P-3K was added and the cell was shaken vigorously. The cell was left to stand for 5 minutes and then the mg/l PO<sub>4</sub>-P was determined using a Merck Spectroquant Pharo 300 spectrophotometer. For the determination of orthophosphate, the digestion step was excluded.

#### 4.4.6 Ammonium and total nitrogen measurements

Ammonium and total nitrogen test kits from Merck Spectroquant were used to perform ammonium and total nitrogen measurements on the sludge samples in this study. A measuring range of 4.0-80.0 mg/l NH<sub>4</sub>-N were used for ammonium testing, and two different measuring ranges were used for total nitrogen testing: 0.5-15.0 mg/l and 10-150 mg/l. In a thermoreactor, organic and inorganic nitrogen compounds are transformed to nitrate by treatment with an oxidizing agent. This nitrate reacts with 2,6-dimethylphenol to form 4-nitro-2,6-dimethylphenol which can be determined photometrically to establish the total nitrogen value (*further information can be found in the Merck Spectroquant instruction manual*). As described in the Merck Spectroquant instruction manual, 10 ml of diluted sample was pipetted into an empty cell. 1 level of reagent N-1K was added and the cell was mixed. After mixing, 6 drops of reagent N-2K was added and the cell was mixed additionally. The prepared cell was left to heat at 120 °C in a thermoreactor for 1 hour. 1 ml of sample was extracted from the digested, cooled sample and pipetted into a reaction cell. 1 ml of reagent N-3K was added and the cell contents were mixed. The reaction cell was left to stand for 10 minutes and then measured in a Merck Spectroquant Pharo 300 spectrophotometer.

Ammonium nitrogen will occur as ammonium and as ammonia. Ammonium nitrogen is present almost utterly as ammonia when in a strongly alkaline environment. This ammonia reacts with hypochlorite ions and forms monochloramine. Monochloramine reacts with substituted phenol to form a derivative indophenol that is blue in colour and can be determined photometrically to establish the ammonium value (*further information can be found in the Merck Spectroquant instruction manual*). As described in the Merck Spectroquant instruction manual, 0.10ml of diluted sample was pipetted into a reaction cell and mixed. To the diluted sample, acid was added until a pH of under 6 was reached. In this way, no loss of nitrogen in form of NH<sub>3</sub> in

the gas will occur. After mixing, 1 dose of reagent NH<sub>4</sub>-1K was added and the reaction cell was shaken vigorously. The cell was left to stand for 15 minutes and then measured in a Merck Spectroquant Pharo 300 spectrophotometer.

Ammonia concentrations were calculated based on the determined ammonium concentrations and the pH (Equation 1).

#### 4.5 Error and accuracy analysis

The WTW Multi 340i, used for pH and conductivity measurements, provided the following instrument specifications: pH accuracy;  $\pm 0.01$  pH,  $\pm 1$  mV. Conductivity accuracy;  $\pm 1\%$  of value. The pH accuracy value is also applicable for the VFA measurements.

The AMPTS II CO<sub>2</sub>-absorbing Unit (unit B) had a measured absorption efficiency of  $>98\%$ . the Gas Volume Measuring Device (unit C) had a measured accuracy of  $5\%$  (relative accuracy error) and a precision of  $1\%$  (coefficient of variation) (Bioprocess control, u.d.).

The cell test kits from Merck Spectroquant provided analytical quality assurance in their instruction manuals (Table 10).

*Table 10 Characteristic quality data and characteristic procedure data of cell test kits from Merck Spectroquant*

<b>Cell test</b>	<b>Measuring range</b>	<b>Unit</b>	<b>Standard deviation of the method</b>	<b>Accuracy of measurement value</b>
COD	50-500	mg/l COD	$\pm 2.0$	max $\pm 13$
COD	500-10000	mg/l COD	$\pm 31.3$	max $\pm 143$
Phosphate	0.05-5.00	mg/l PO <sub>4</sub> -P	$\pm 0.024$	max $\pm 0.08$
Ammonium	4.0-80.0	mg/l NH <sub>4</sub> -N	$\pm 0.49$	max $\pm 1.9$
Nitrogen (Total)	10-150	mg/l N	$\pm 1.1$	max $\pm 5$
Nitrogen (Total)	0.5-15	mg/l N	$\pm 0.14$	max $\pm 0.6$

## 5. Results

The results of the experiments performed in this study are presented in the order that they were executed. The results are presented in three main sections: section 1 is the sludge characteristics and includes an analysis of the substrates that were used in all the experiments. The results from this section were further used for both the experiments in section 2 and section 3. Section 2 includes the results from the batch tests and section 3 includes the results from the daily fed stirred tank reactors. Some of the results from section 2 were further used for the experiments in section 3.

### 5.1 Section 1: Sludge characteristics

The substrates used in this study were analysed to define the sludge characteristics (Table 11). TS, TVS, COD, total dissolved nitrogen and total dissolved phosphorus were determined. The standard deviation of the results was calculated using Microsoft Excel.

*Table 11 Sludge characteristics of substrates used in the experiments of this study*

Substrate	TS (%)	TVS (%)	COD (g/kg)	Total N (g/kg)	Total P (g/kg)
Aquaculture waste, Fister Smolt	$6.17 \pm 0.02$	$4.86 \pm 0.02$	$68 \pm 5$	$2.93 \pm 0.05$	$1.4 \pm 0.3$
Primary sludge, IVAR	$2.32 \pm 0.05$	$1.92 \pm 0.05$	$30 \pm 2$	$0.98 \pm 0.02$	$0.198 \pm 0.05$
Activated sludge, IVAR	$4.16 \pm 0.01$	$3.18 \pm 0.01$	$53 \pm 0.5$	$0.73 \pm 0.03$	$0.205 \pm 0.01$

The aquaculture waste from Fister Smolt had a 2.7 times more concentrated COD value than the primary sludge from IVAR. However, when measured as fraction of TVS, the COD (g/kg) of the aquaculture sludge and the primary sludge were fairly similar (1.4 and 1.6 respectively). In addition to this the aquaculture waste had a greater level of nitrogen and phosphorus, yet when compared as a fraction of TVS the concentrations of nitrogen were fairly similar (0.60 and 0.51 respectively). The phosphorus on the other hand had a larger difference when compared as fractions of TVS (0.28 and 0.10 respectively). The activated sludge from IVAR had higher TS, TVS and COD concentrations than the primary sludge, however when measured as fractions of TVS, the COD (g/kg) were almost similar (1.7 and 1.6 respectively). The



nitrogen and phosphorus levels of the activated sludge were considerably lower when compared as fractions of TVS (0.22 and 0.51 respectively, and 0.06 and 0.10 respectively).

In comparison to the aquaculture waste from Fister Smolt, the aquaculture waste analyzed by Aquateam COWI (Table 1) had a much larger TS and TVS content. However, the nitrogen levels (compared as fraction of TVS) were almost the same (0.60 and 0.61 respectively). The phosphorus levels were significantly lower in the Aquateam COWI waste compared to that of Fister Smolt (0.10 and 0.51 respectively).

## 5.2 Section 2: Batch tests

The accumulated methane production and the methane flowrate during digestion of the substrates in the two batch tests were determined using the AMPTS II system (Figure 9, Figure 10, Figure 11 and Figure 12). Each series represent the average of two parallels of the specific reactor, and the standard deviation of the results from the parallels was calculated using Microsoft Excel. The figures present the total methane production, as the methane produced in the blanks has not been subtracted.

The co-digestion of 25% aquaculture waste with 75% primary sludge (F+K 2,7 g COD) showed the highest methane production in batch test 1.0 (Figure 9). However, this mix also had the highest COD load. Accordingly, the primary sludge (K 2 g COD) and the 50% COD/COD mix (F+K 2 g COD) produced approximately the same amount of methane. As did the aquaculture waste (F 2 g COD), although it was briefly lower than the two other series with the same COD concentration. Further on, the primary sludge (K 1 g COD) and the aquaculture waste (F 1 g COD) also produced approximately the same amount of methane. The blank had the lowest methane production in batch test 1.0.

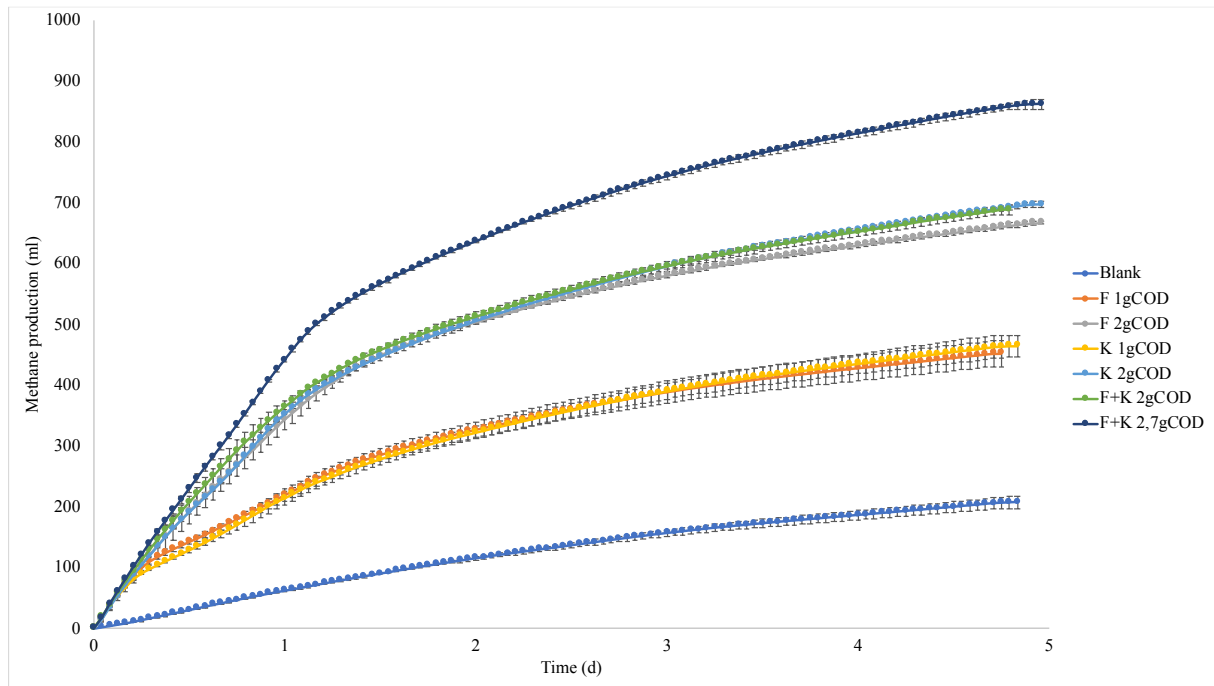

Figure 9 Methane production in batch test 1.0

The flowrate of the methane production (Figure 10) in batch test 1.0 is the methane production rate given in ml/h. All series, except the blank, experienced a decrease in the flowrate at around 1 day. The series with the highest loading (COD) showed the highest production rate. The test was terminated at day 5 when the methane production of all series entered a methane production phase similar to that of the blank.

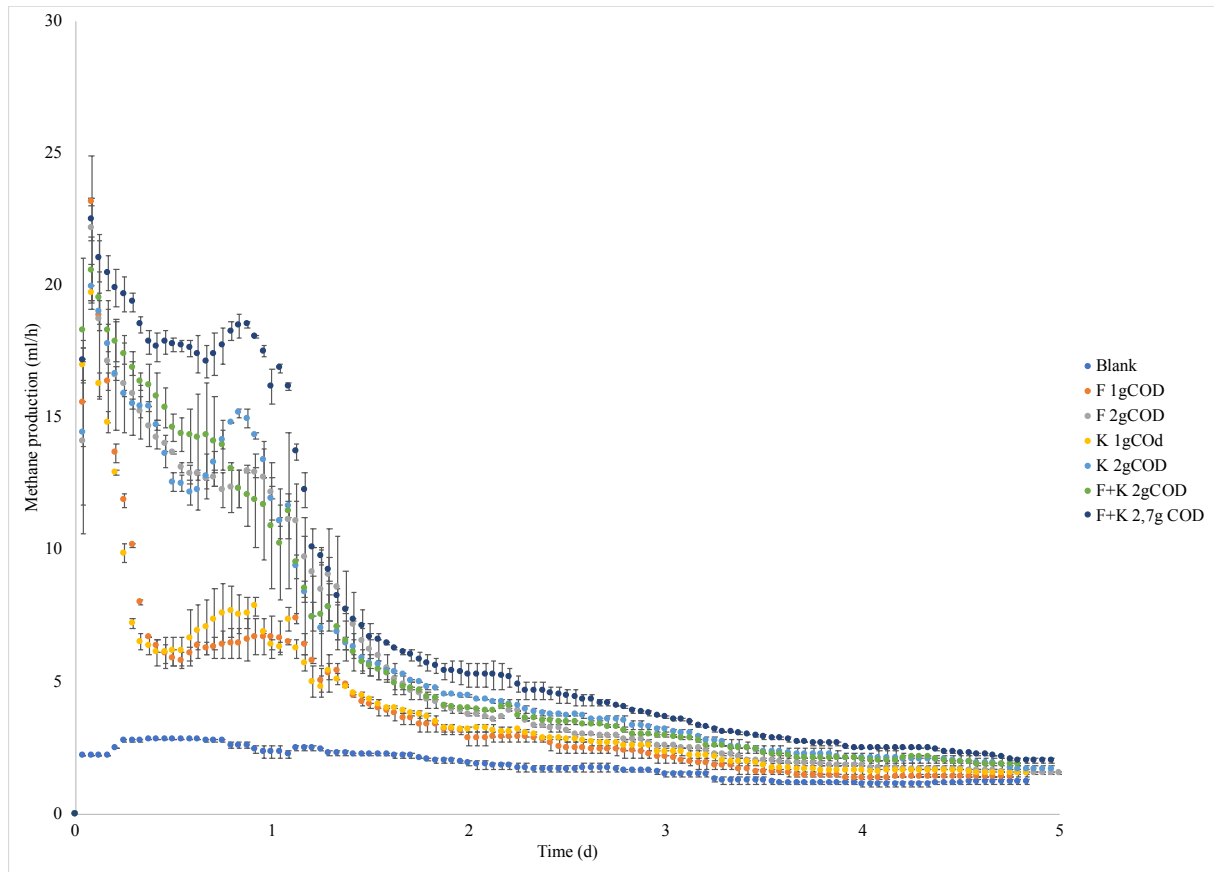

Figure 10 Flowrate of the methane production in batch test 1.0

The co-digestion mix (50% COD/COD) of aquaculture waste with activated sludge (F+AS 2 g COD), and the aquaculture waste (F 2 g COD) showed the highest methane productions in batch test 2.0 (Figure 11). The activated sludge (AS 2 g COD) however, produced a lower volume of methane than the two other series with the same COD load. The blank had the lowest methane production in batch test 2.0.

The average methane production of the aquaculture sludge (F 2g COD) in batch test 2.0 was 650 ml on day 5 (Figure 11), which corresponded well with the average methane production of the aquaculture sludge (F 2g COD) in batch test 1.0, which was 668 ml on day 5 (Figure 9).

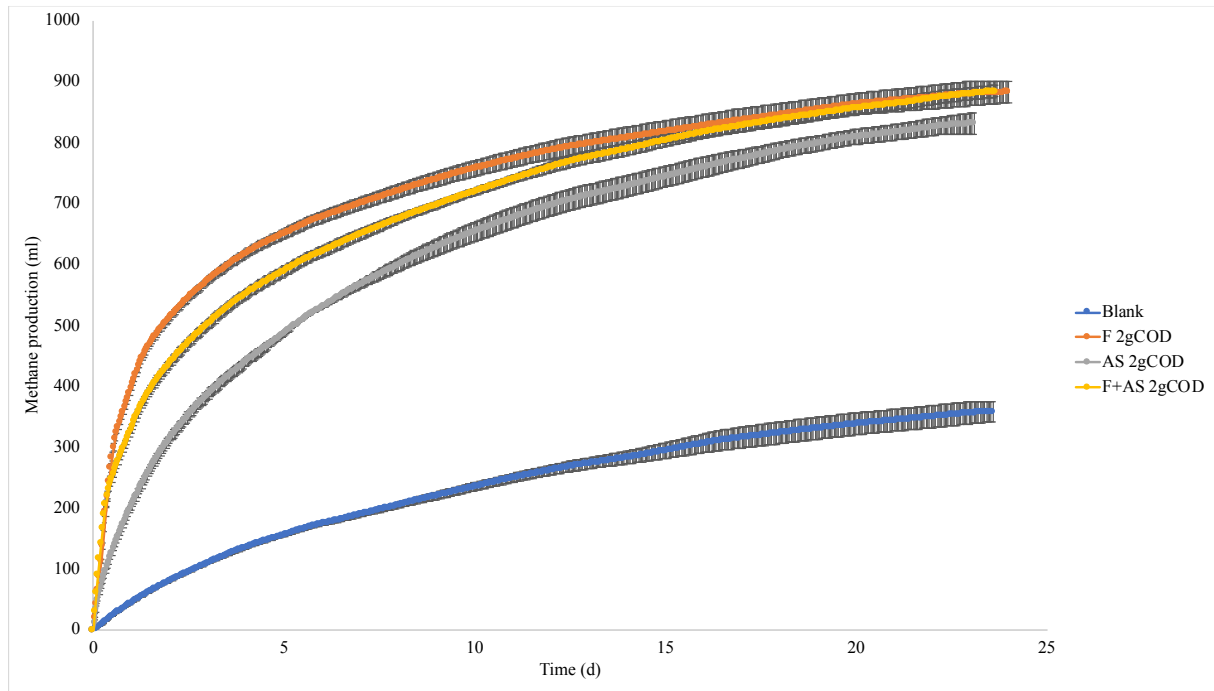

Figure 11 Methane production in batch test 2.0

The flowrate of the methane production in batch test 2.0 (Figure 12) is the methane production rate given in ml/h. The test was terminated when the methane production from all series was less than 5Nml/day, which occurred after 25 days. All series, except the blank, experienced a decrease in the flowrate at around 1.5 days. The activated sludge (AS 2 g COD) had a lower methane production rate compared to the aquaculture sludge (F 2 g COD), and the co-digestion mix (F + AS 2 g COD) had a methane production rate that were in the middle of these two (Figure 11).

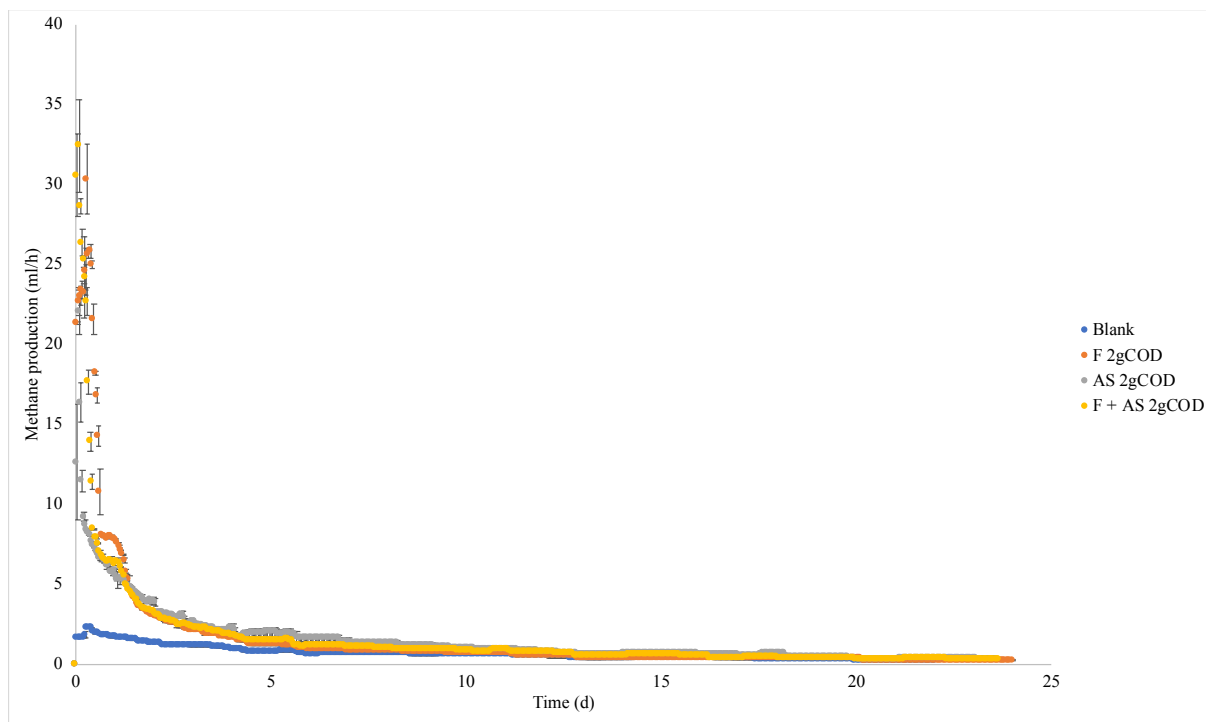

Figure 12 Flowrate of the methane production in batch test 2.0

The BMP (g COD/g COD) of the substrates utilized in batch test 1.0 were fairly similar, with an average BMP of 0.70 g COD/ g COD (Table 12). However, the primary sludge from IVAR achieved the highest yield as 0.72 g COD/g COD were converted to methane, and thus this sample also had the highest degradation. The BMP (ml CH<sub>4</sub>/g TVS) also follows the trend from the g COD/g COD measurements. However, due to the high sludge concentration, the aquaculture waste from Fister Smolt showed the highest methane production when compared as m<sup>3</sup> CH<sub>4</sub>/ m<sup>3</sup>. Co-digestion of aquaculture waste and primary sludge did not give an increased methane yield in batch test 1.0.

Table 12 Biomethane potential (BMP) of batch test 1.0

Substrate	BMP (g COD/g COD)	BMP (ml CH <sub>4</sub> /g TVS)	BMP (m <sup>3</sup> CH <sub>4</sub> / m <sup>3</sup> )
Aquaculture waste, Fister Smolt	0.69 ± 0.05	340 ± 13	17 ± 1
Primary sludge, IVAR	0.72 ± 0.04	391 ± 12	7.5 ± 0.4
50% COD/COD mix	0.69 ± 0.01	356 ± 4	10.0 ± 0.1
25% aquaculture waste and 75% primary sludge	0.70 ± 0.01	367 ± 3	9.7 ± 0.1

The 50% COD/COD mix showed the highest BMP (g COD/g COD) in batch test 2.0, and thus co-digestion of aquaculture waste and active sludge gave a 1% increase in methane yield (Table 13). However, when the standard deviations were taken into account the BMP (g COD/g COD) of the 50% COD/COD mix and the aquaculture waste were quite similar.

When compared as ml CH<sub>4</sub>/g TVS, the 50% COD/COD mix still showed the highest methane yield. On the other hand, the aquaculture waste showed the highest methane yield when the results were compared as m<sup>3</sup> CH<sub>4</sub>/m<sup>3</sup>.

*Table 13 Biomethane potential (BMP) of batch test 2.0*

<b>Substrate</b>	<b>BMP (g COD/g COD)</b>	<b>BMP (ml CH<sub>4</sub>/g TVS)</b>	<b>BMP (m<sup>3</sup> CH<sub>4</sub>/ m<sup>3</sup>)</b>
Aquaculture waste, Fister Smolt	0.75 ± 0.04	367 ± 13	18 ± 1
Active sludge, IVAR	0.67 ± 0.04	395 ± 15	12.5 ± 0.7
50% COD/COD mix	0.76 ± 0.01	406 ± 2	15.9 ± 0.2

Compared to the results from batch test 1.0 which showed the methane yield of the aquaculture waste as 0.69 g COD/g COD (Table 12), the aquaculture waste results from batch test 2.0 were higher (0.75 g COD/ g COD).

### 5.3 Section 3: Daily fed stirred tank reactors

The DFSTR was operated at a 15-day SRT. The results presented in 5.3.1-5.3.4 represent the initial 45 days of the experiment. The results in 5.3.5 represent the next 45 days that were used as a performance test of the system after the steady state condition had been reached.

#### 5.3.1 Alkalinity and pH

The pH of all reactors was measured every day during the system running time (Figure 13). Reactor 1 experienced a slight increase in the pH at day 2, but then returned to a stable pH. The average pH of reactor 1 was  $6.93 \pm 0.09$ . Reactor 2 showed the highest increase in pH of all the reactors, and the pH was rapidly increasing all through the running time, until it reached around 7.3. At day 37 the system encountered an electrical power failure and a pH of 7.50 was measured in reactor 2, which was a deviation to the trend line. Reactor 3 and 4 showed no significant measurement deviations around this day. Similar to reactor 2, reactor 3 also experienced an increase in pH, yet not as large as reactor 2. Reactor 4 showed the lowest pH of all the reactors, with an average pH of  $6.86 \pm 0.09$ .

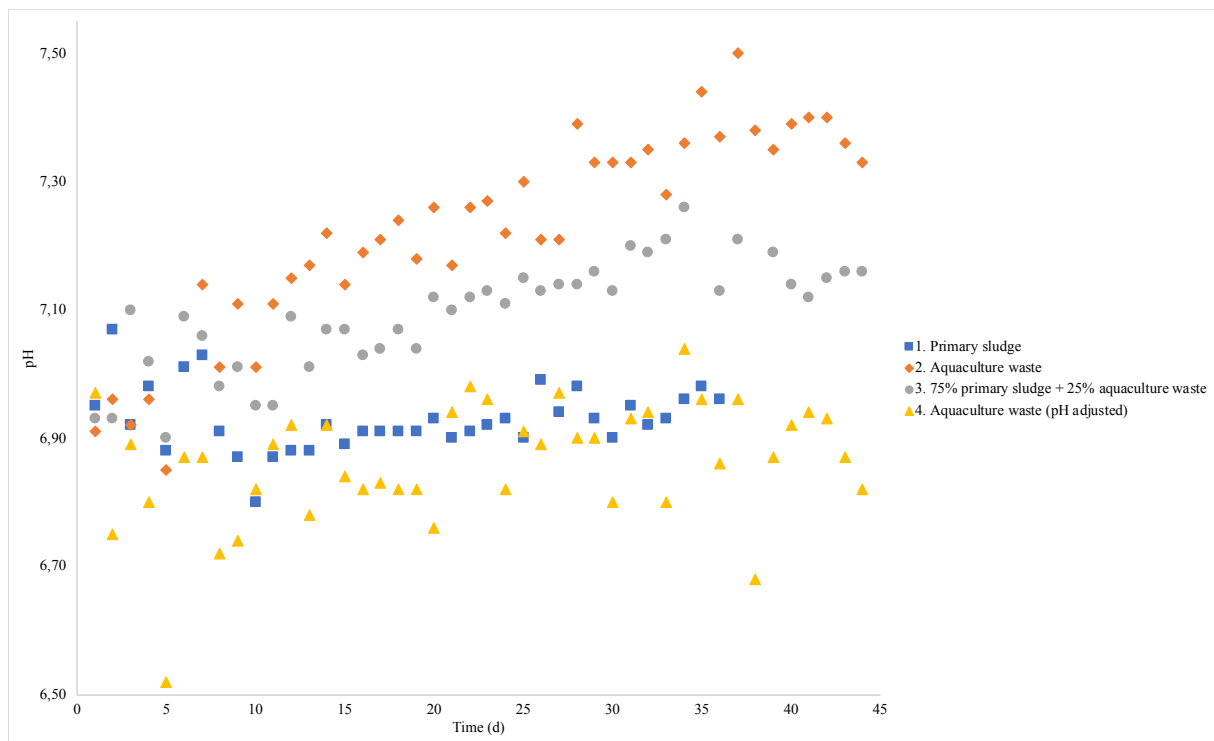

Figure 13 pH of the daily fed stirred tank reactors as a function of time

The alkalinity of all the reactors was measured randomly during the system running time, with more frequent measurements during the 10 first days of the experiment (Figure 14). Reactor 1 had a relatively stable alkalinity during the whole experiment, except for a small decrease around day 33. Reactor 2 showed a rapid increase in alkalinity, which continued during the majority of the experiment. Similar to reactor 1, reactor 3 also had a relatively stable alkalinity during the system running time, however a small decrease was experienced at day 25. During the running time of the system, reactor 4 had a significantly lower alkalinity compared to reactor 2. Both reactor 2 and reactor 4 experienced a decrease in alkalinity at day 40. Reactor 3 showed no significant measurement deviations around this day.

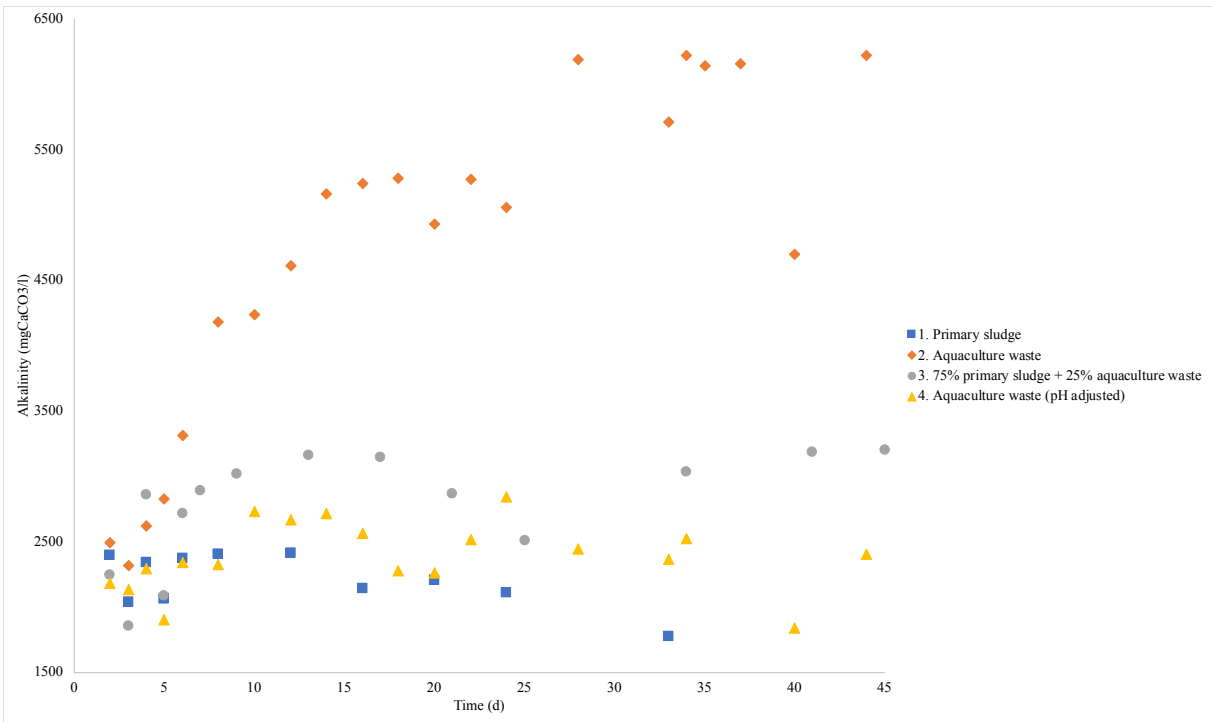

Figure 14 Alkalinity (as CaCO<sub>3</sub>) of the daily fed stirred tank reactors as a function of time



### 5.3.2 Ammonium

Ammonium concentrations ( $\text{mg/l NH}_4^+$ ) of all the reactors was measured randomly during the system running time (Figure 15). Both reactor 2 and 4 showed an increase in the concentration of ammonium during the experiment, however with some individual differences. Reactor 1 and 3 on the other hand showed a significantly lower ammonium concentration, and reactor 1 had the lowest and most stable amount of ammonium of all the reactors.

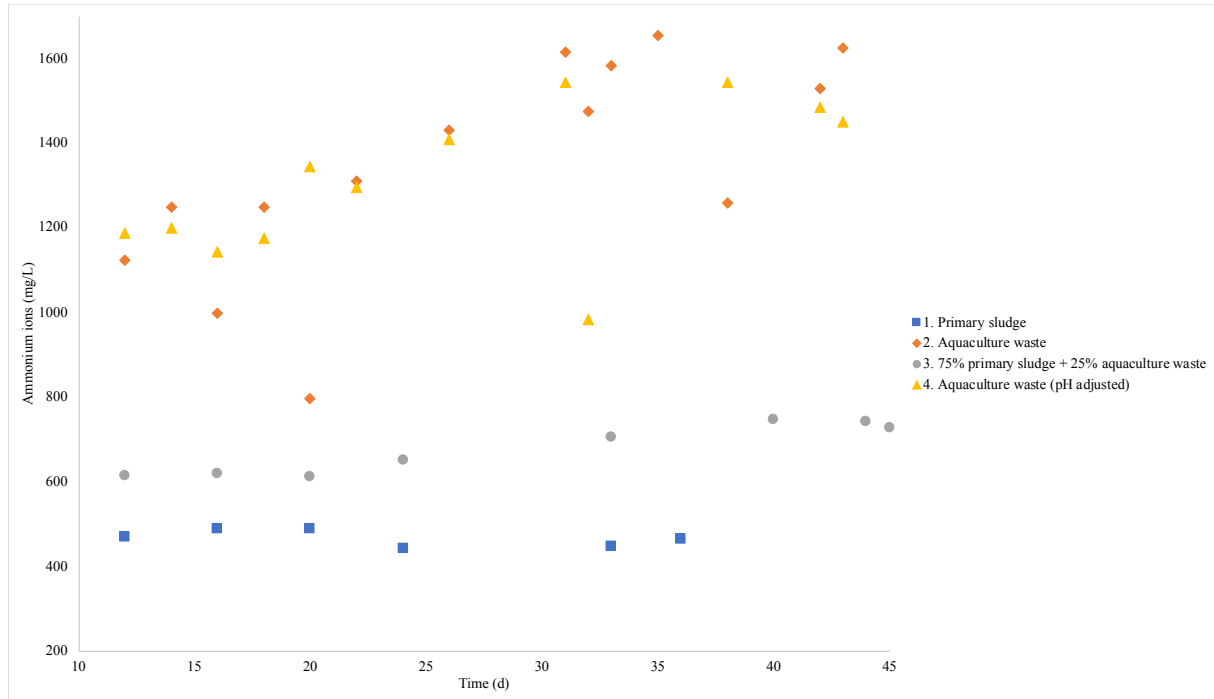

Figure 15 Ammonium concentrations of the daily fed stirred tank reactors as a function of time

### 5.3.3 Methane production and VFA

The aquaculture waste reactors (2 and 4) showed the highest daily methane production. These reactors also had the highest loading rate (3.4 g COD/d). A similar pattern was shown with reactor 3 (2.0 g COD/d) that produced less than reactor 2 and 4, yet more than reactor 1 (1.5 g COD/d). Stationary growth was reached for all reactors approximately 24 hours after feeding, and the daily methane production (ml) could be determined (Figure 16).

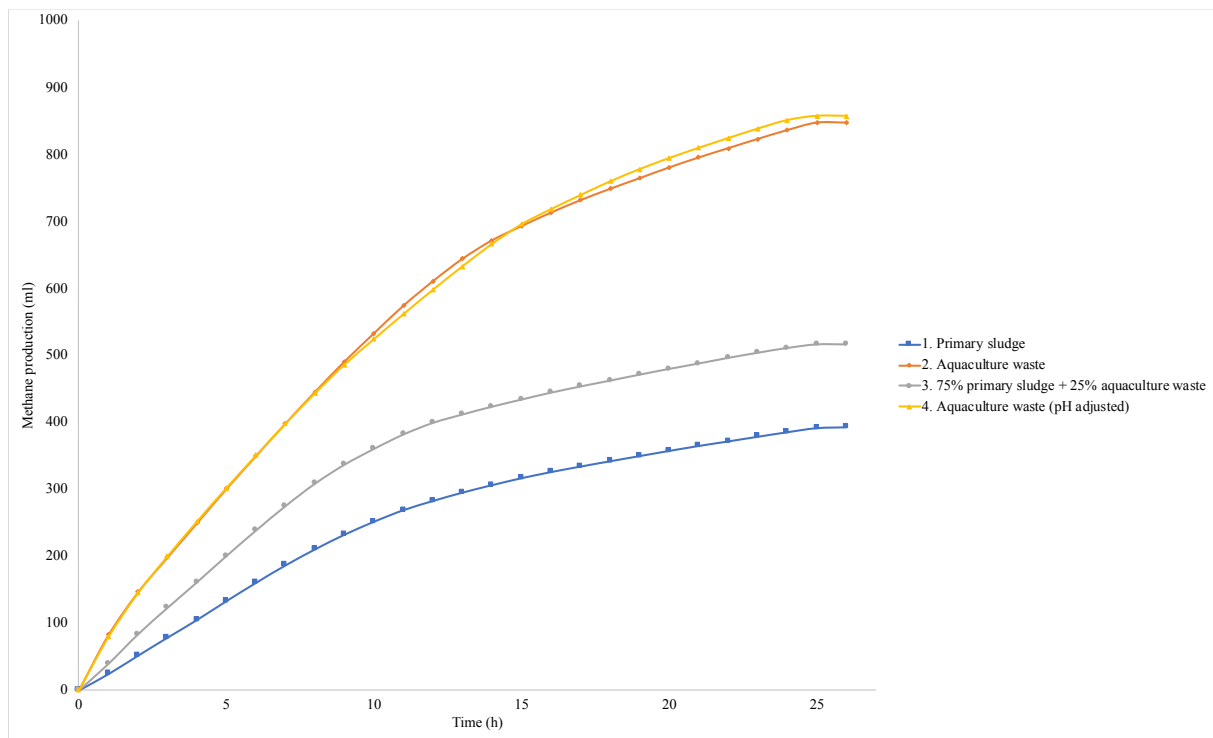

Figure 16 Methane production in the daily fed stirred tank reactors at day 16

The reactors were fed at different times each day, and therefore the produced methane (ml) values were standardized to be the methane produced for 24 hours (ml/day). Measuring errors or feeding accuracy errors were expected, and this might have caused variations in the overall measurements when methane production in ml was calculated to methane production in g/COD/d (Figure 17). All reactors produced approximately the same amount of methane (g COD/d) in the first 2 days, however reactor 2 and 4 experienced a rapid increase in methane production (g COD/d) at day 3 (Figure 17). Reactor 2 had an average methane production of  $2.32 \pm 0.39$  g COD/d, while reactor 4 had an average methane production of  $2.27 \pm 0.35$  g COD/day. On average, these results were 2.21 times more than the methane production from reactor 1 and 1.63 times more than the methane production from reactor 3.

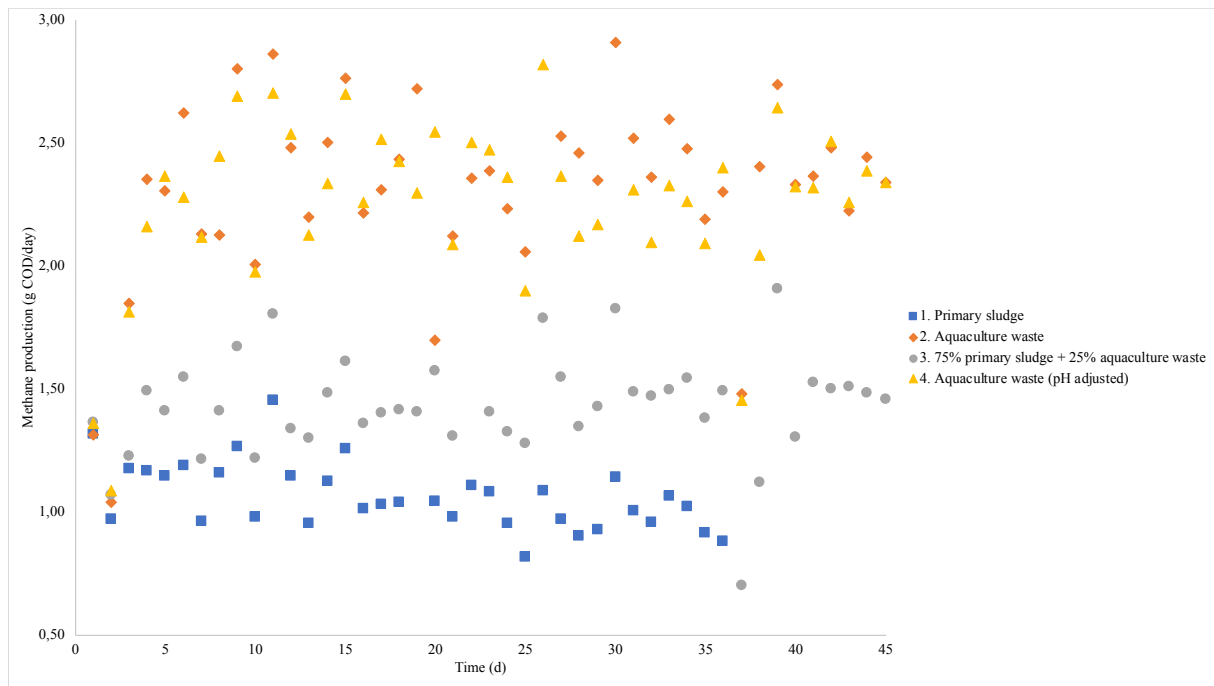

Figure 17 Methane production (g COD/d) of the daily fed stirred tank reactors as a function of time

The VFA concentrations (mg/l) of all the reactors was measured randomly during the system running time, with more frequent measurements during the 10 first days of the experiment (Figure 18). Reactor 1 and 3 showed relatively low and stable VFA concentrations, compared to reactor 2 and 4 that had higher and more unstable VFA concentrations.

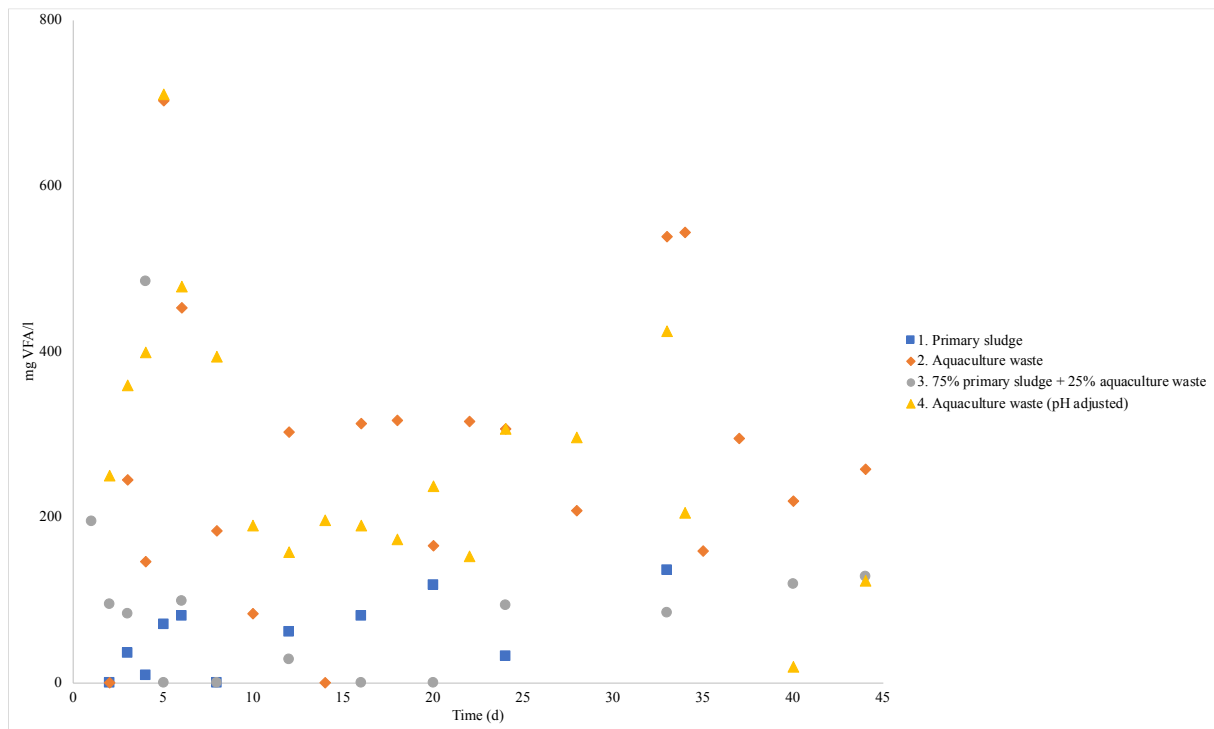

Figure 18 Volatile fatty acid concentrations (mg/l) of the daily fed stirred tank reactors as a function of time

### 5.3.4 Steady state characteristics

Steady state conditions were assumed after 45 days (3 x SRT), and COD, nitrogen and phosphorus mass balances were determined (Table 14 Table 15 Table 16).

At steady state, reactor 1 had a COD removal of 71% (Table 14). The COD mass balance of the reactor was 97%. Reactor 2 and 3 both had a total mass balance of 101%, however reactor 2 showed a COD removal of 69%, while the COD removal in reactor 3 was 73%. Reactor 4 achieved a 68% COD removal and an overall mass balance of 99%.

*Table 14 COD steady state evaluation*

Substrate	Influent (g COD/d)	Methane production (g COD/d)	Methane yield (g COD/gCOD)	Effluent (g COD/d)	COD removal (%)	Mass balance (%)
Primary sludge, IVAR	1.5	1.0	0.68	0.44	71	97
Aquaculture sludge, Fister Smolt	3.4	2.4	0.70	1.06	69	101
75% primary s + 25% aquaculture waste	2.0	1.5	0.74	0.53	73	101
Aquaculture waste (pH adjusted*)	3.4	2.3	0.67	1.09	68	99

72% of the nitrogen in reactor 1 was accounted for, while the aquaculture reactors, 2 and 4, showed a nitrogen mass balance of 87-88% (Table 15). Reactor 3 achieved a nitrogen mass balance of 82%. None of the mass balances reached 100%, which was not expected as NH<sub>3</sub> was in the gas phase and could also possibly have been lost under storage and sampling. The nitrogen in the reactor that was dissolved as ammonia could be determined from the total influent nitrogen: 51% of the total ammonium was converted to ammonia in reactor 1, 55% in reactor 2, 48% in reactor 3 and 48% in reactor 4.

*Table 15 Total nitrogen steady state evaluation*

Substrate	Influent N (g/l)	Effluent N (g/l)	Measured ammonia (g N/l)	Mass balance (%)
Primary sludge, IVAR	0.98	0.71	0.5	72
Aquaculture sludge, Fister Smolt	2.93	2.55	1.6	87
75% primary s + 25% aquaculture waste	1.47	1.20	0.7	82
Aquaculture waste (pH adjusted*)	2.93	2.59	1.4	88

The total phosphorus content of reactor 1 was at 117% compared to the influent at day 0 (Table 16). Reactor 3 had a mass balance of 100%, while reactor 2 and 4 achieved a phosphorus mass balance of 68-88%. Determination of phosphorus was difficult as the substrate consistency of the aquaculture waste and primary sludge was thick and hard to properly homogenize.

*Table 16 Total phosphorus steady state evaluation*

<b>Substrate</b>	<b>Influent P (g/l)</b>	<b>Effluent P (g/l)</b>	<b>Mass balance (%)</b>
Primary sludge, IVAR	0.198	0.23	117
Aquaculture sludge, Fister Smolt	1.4	0.948	68
75% primary s + 25% aquaculture waste	0.5	0.502	100
Aquaculture waste (pH adjusted*)	1.4	1.235	88

A sludge removal of 73% TVS was achieved in reactor 1, 65% in reactor 2, 71% in reactor 3 and 59% in reactor 4 (Table 17). The sludge removal percentages of reactor 1,2 and 3 corresponded with the COD removal from the COD steady state evaluation (Table 14).

*Table 17 Sludge removal in the DFSTR*

<b>Substrate</b>	<b>Influent TS (%)</b>	<b>Influent TVS (%)</b>	<b>Effluent TS (%)</b>	<b>Effluent TVS (%)</b>	<b>TS removal (%)</b>	<b>TVS removal (%)</b>
Primary sludge, IVAR	2.3	1.9	0.9	0.5	61	73
Aquaculture sludge, Fister Smolt	6.2	4.9	3.6	1.7	42	65
75% primary s + 25% aquaculture waste	3.3	2.7	1.4	0.8	57	71
Aquaculture waste (pH adjusted*)	6.2	4.9	3.5	2.0	44	59

pH, VFA, alkalinity and CO<sub>2</sub> fractions in the biogas during the steady state was determined (Table 18). Reactor 2 showed the highest pH, VFA and alkalinity while reactor 4 on the other hand showed the lowest pH and VFA. The CO<sub>2</sub> in gas phase was higher in the reactors fed aquaculture waste (2 and 4).

Table 18 Environmental conditions during steady state

Substrate	pH	VFA (mg/L)	Alkalinity (g/L)	CO <sub>2</sub> in gas phase (%)
Primary sludge, IVAR	6.96	135	1.8	43±0.03
Aquaculture sludge, Fister Smolt	7.33	258	6.2	47±0.02
75% primary s + 25% aquaculture waste	7.16	128	3.2	43±0.01
Aquaculture waste (pH adjusted*)	6.82	123	2.4	50±0.02

### 5.3.5 Extended performance test

The aquaculture waste reactors 2 and 4 were continued for 45 additional days (3 x SRT) to test the performance when a constant ammonium concentration of around 1.6 g/l was reached. The same parameters as described earlier were evaluated.

During the first days of the experiment, the pH was around 7.4-7.6 in reactor 2 and 6.9 in reactor 4. A small decrease to a pH of around 7.3 was experienced in reactor 2 after this. On day 73, 2 g COD HAc (Sigma Aldrich) was added as a positive control together with 2.27 mg/l CaCO<sub>3</sub> (Sigma Aldrich). The addition of HAc and CaCO<sub>3</sub> increased the pH in both reactors (Figure 19). On day 75, 2.83 ml 37% HCl was added to remove the excess CaCO<sub>3</sub>, and 1g COD HAc was added as a positive control. A decrease in the pH of both reactors was seen after this addition.

A clear trend was observed in that when the pH increased, so did the ammonia concentrations. Furthermore, when the pH decreased as did the ammonia concentrations. Ammonium concentrations were constant at around 1.6 g/l in both reactors, and the only parameter observed to affect ammonia concentrations was the pH. An inhibited steady state was assumed when accumulation of VFA lead to a decrease in pH which again lead to a decrease of ammonia (Figure 19, Figure 20, Figure 21).

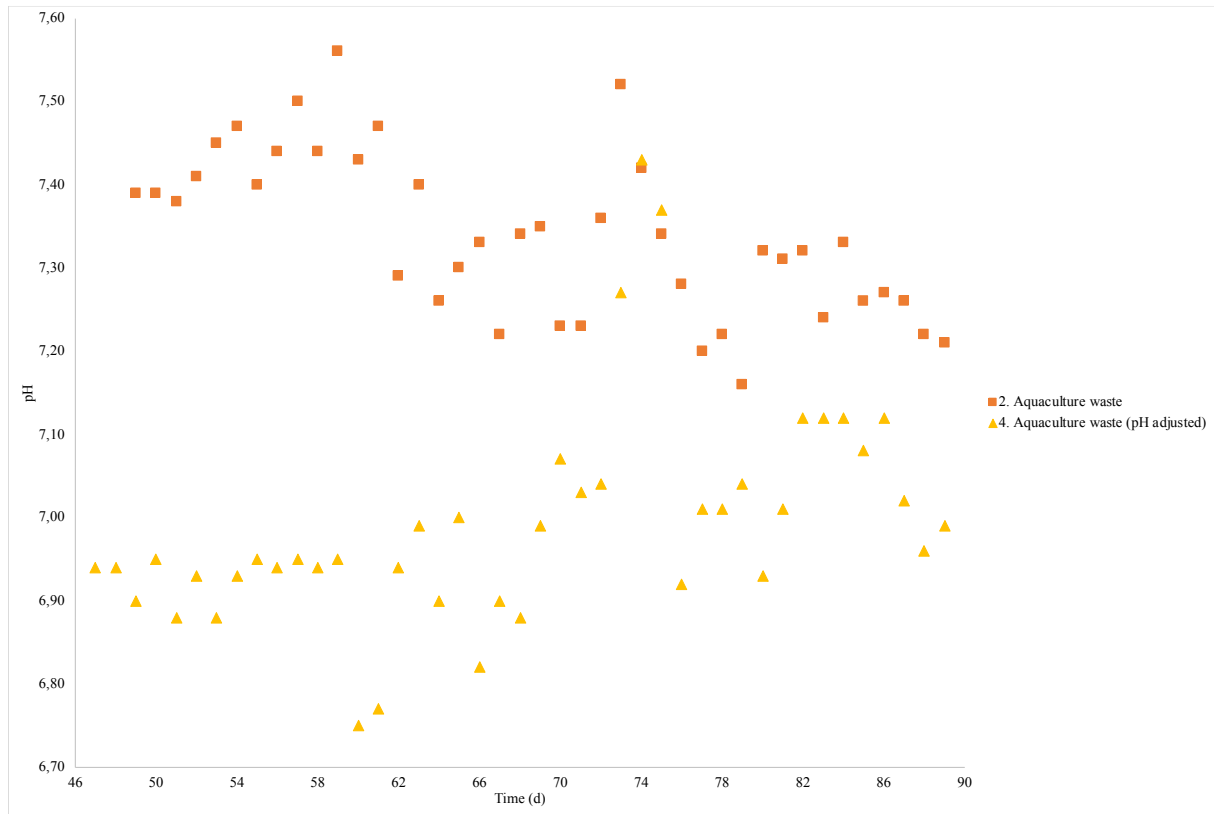

Figure 19 pH of the daily fed stirred tank reactors 2 and 4 as a function of time

An increase in VFA concentration from an average of  $688 \pm 101$  to  $2767$  mg/l was observed in reactor 2 on day 74 (Figure 20). A decrease was observed after day 75, however the VFA concentration in reactor 2 remained high for the remainder of the experiment. An increase in VFA concentration was also observed in reactor 4 on day 74, however not as significant as in reactor 2. The VFA concentration in reactor 4 was to some extent re-stabilized after day 75.

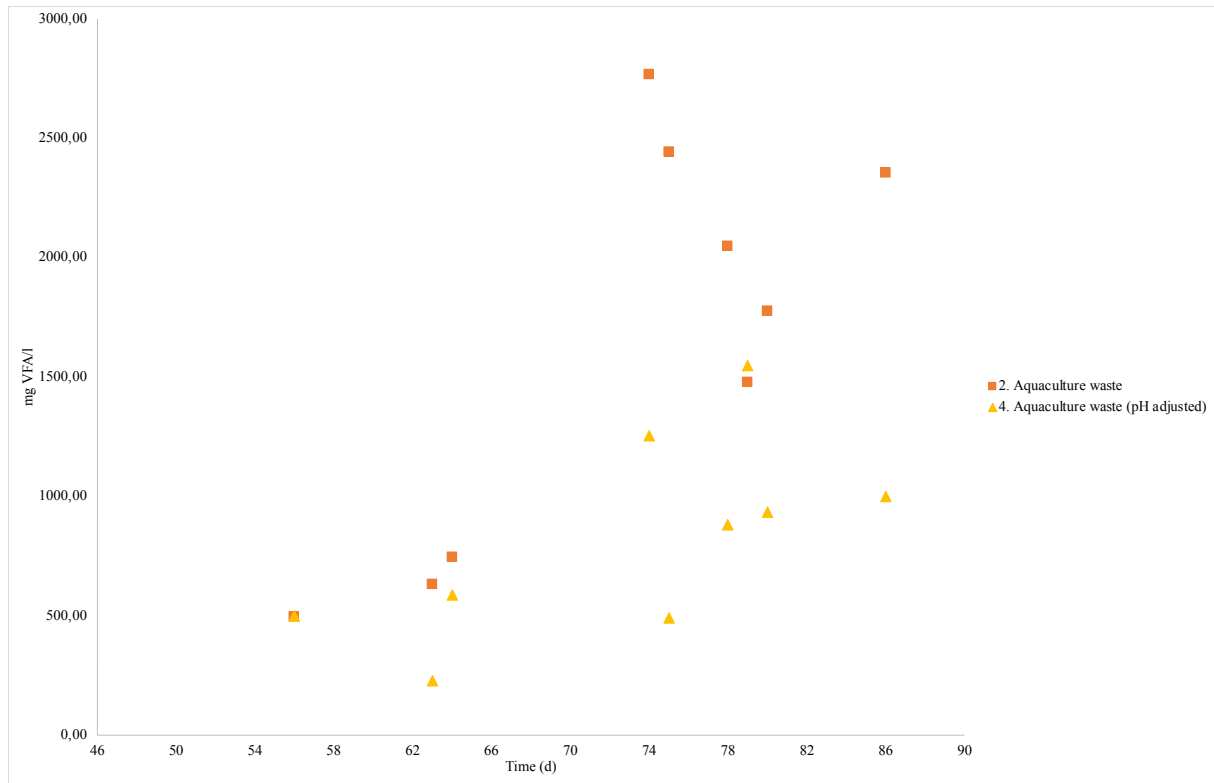

Figure 20 Volatile fatty acids concentration (mg/l) in the daily fed stirred tank reactors 2 and 4 as a function of time

Both reactors had a stable ammonium concentration during the extended performance test. Reactor 2 had an average of  $1656 \pm 116$  mg/l  $\text{NH}_4^+$  and reactor 4 had an average of  $1561 \pm 124$  mg/l  $\text{NH}_4^+$ .

During the first part of the experiment, reactor 2 had an average ammonia concentration of  $42 \pm 5$  mg/l  $\text{NH}_3$  (Figure 21). A decrease in ammonia was observed on day 78 (26 mg/l  $\text{NH}_3$ ), and the ammonia concentration was 34 mg/l  $\text{NH}_3$  when reactor 2 was terminated. Reactor 4 however had an average ammonia concentration of  $13 \pm 2$  mg/l  $\text{NH}_3$  during the first part of the test, yet a large increase was observed on day 74 (48 mg/l  $\text{NH}_3$ ). The ammonia concentration was 18 mg/l  $\text{NH}_3$  when reactor 4 was terminated.



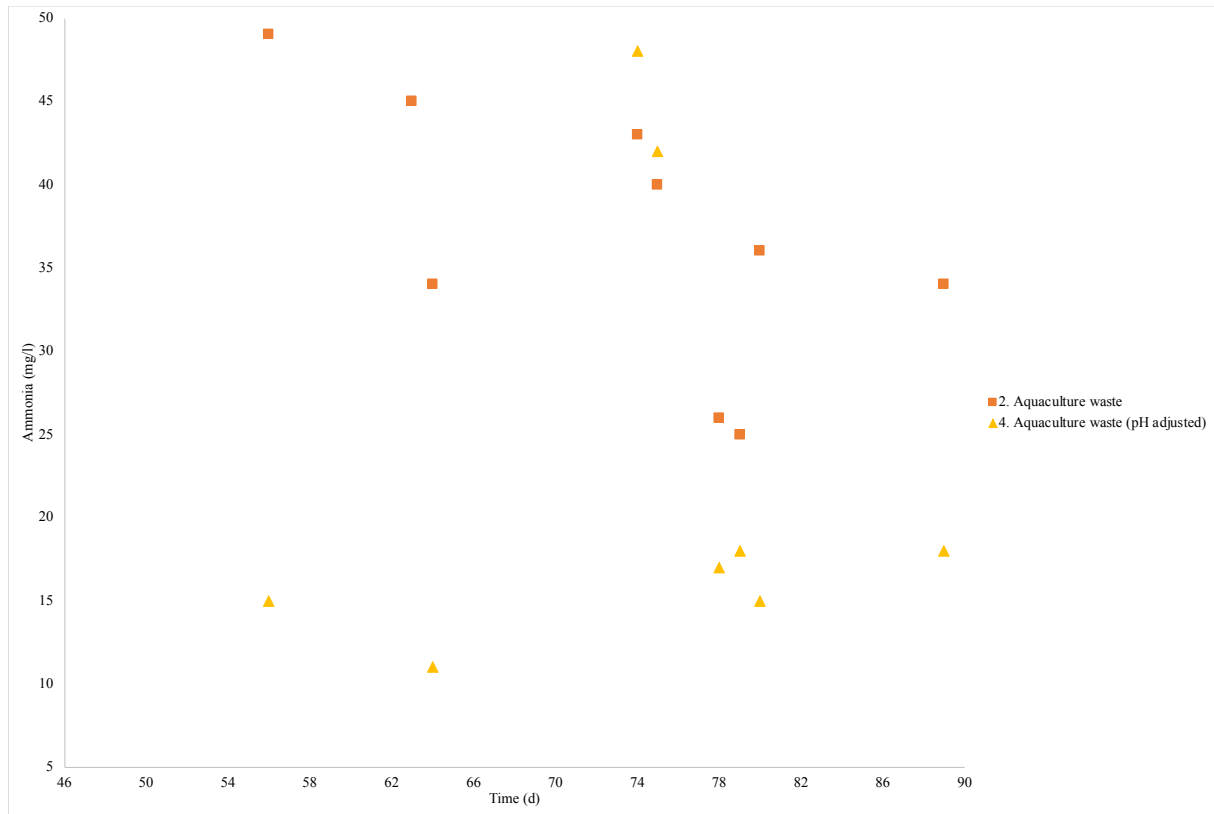

Figure 21 Ammonia concentrations (mg/l) in the daily fed stirred tank reactors 2 and 4 as a function of time

Methane was produced at a stable rate for the majority of the experiment in both reactors (Figure 22). Due to measuring errors, some measurements from day 82-90 have been removed. A significant decrease in methane production was observed in both reactors on day 73 as a result of the positive control. Further, an increase in methane production was observed in both reactors after day 75.

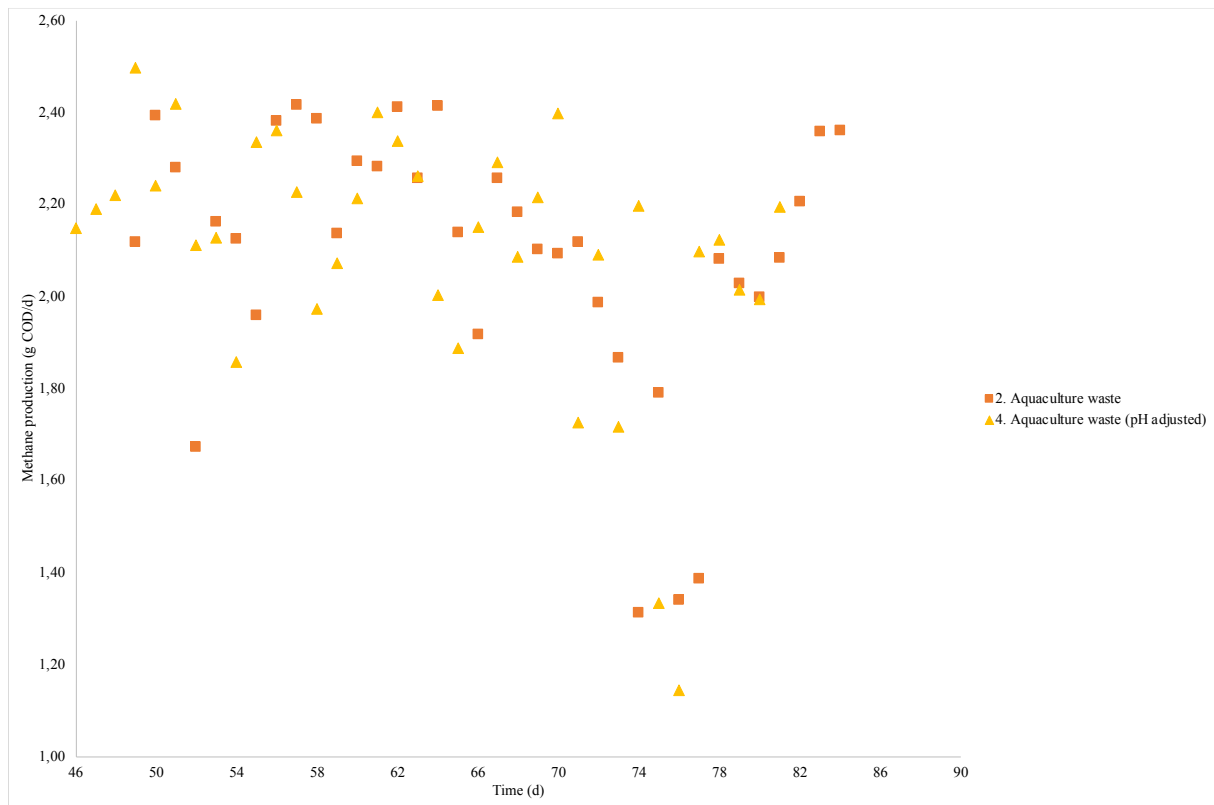

Figure 22 Methane production (g COD/d) of the daily fed stirred tank reactors 2 and 4 as a function of time

## 6. Discussion

### 6.1 Biogas production potential and sludge removal

A hypothesis for this study was that aquaculture waste has a higher nitrogen content than municipal waste. However, when compared as fractions of TVS the aquaculture waste and primary sludge were quite similar in regard to nitrogen content (Table 11). Large differences in TS (%) concentrations of the substrates utilized in this study were observed. The aquaculture waste from Fister Smolt had a TS concentration of  $6.17\% \pm 0.02$ , while the primary sludge from IVAR had a TS concentration of  $2.32\% \pm 0.05$ . The activated sludge from IVAR on the other hand, had a TS concentration of  $4.16\% \pm 0.01$ . These differences were caused by the dewatering process in the facilities.

The results from batch test 1.0 showed a clear trend in that the substrate series with the highest loading (COD) also had the highest methane production (Figure 9). This confirmed that the output COD is directly related to the input COD. In addition to this, the methane flow rate also seemed to follow the loading trend, and the series with the highest loading (COD) also had the highest methane production flowrates (Figure 10). This finding might indicate that it is the hydrolysis step of the anaerobic digestion that is the limiting factor for the batch process.

The primary sludge gave the highest BMP (g COD/g COD) in batch test 1.0, and even though the BMP results of all four substrates and substrate mixes had a BMP of around 0.70 g COD/g COD, co-digestion of aquaculture waste and primary sludge did not result in an observed increased methane yield (Table 12).

The results from batch test 2.0 confirmed the results from batch test 1.0 in that the series with the highest COD load achieved the highest methane production (Table 13). One exception from this was that the 2 g COD activated sludge which produced a lower amount of methane than the other 2 g COD series. This indicated that activated sludge has a higher non-biodegradable fraction compared to primary sludge and aquaculture waste. However, this was expected: Zhou, Wang, & Jiang, 2015 stressed that methane production from waste activated sludge during anaerobic digestion is limited by the slow rate of hydrolysis and/or possibly also by a poor methane potential of the waste activated sludge substrate.

The aquaculture waste in batch test 2.0 achieved a higher BMP than the same aquaculture waste in batch test 1.0 (0.69 g COD/g COD). This is likely due to the fact that batch test 1.0 was

terminated after only 5 days while batch test 2.0 was run for 25 days. At long time operations, the growth rate will be reduced, and more methane will be produced from biomass decay.

In batch test 2.0 co-digestion of aquaculture waste and activated sludge (50% COD/COD mix) achieved a 1% increase in methane yield compared to that of aquaculture waste alone (Table 13). However, this value was too low to confirm an actual increase in methane yield. Some measurement errors related to the weighing and transfer of substrate, and analytical accuracy, might have affected the results. Such errors might be a reason for substrates of the same COD load not producing exactly the same amount of methane.

The DFSTR was operated at a 15-day SRT, with a total of 45 days. During the first days the methane produced from all the reactors were approximately the same, however a rapid increase in methane production was observed in the aquaculture waste reactors (2 and 4) on day 3, and reactor 2 and 4 produced 2.21 times more methane than reactor 1, and 1.63 times more methane than reactor 3 (Figure 17). This was expected as the daily organic load of reactor 2 and 4 were 2.27 times higher than that of reactor 1, and 1.7 times higher than that of reactor 3. These results further confirm the findings from the batch test: the higher the COD load the higher the methane production.

BMP calculations from the DFSTR showed that co-digestion of aquaculture waste and primary sludge (0.74 g COD/g COD) showed a 6% increase in methane yield compared to that of the aquaculture waste alone (0.70 g COD/g COD) and the primary sludge alone (0.68 g COD/g COD) (Table 14). However, this value (6%) was not regarded as significant enough to confirm an actual increase in methane yield.

The reactors were fed at different times every day, and therefore the produced methane (ml) values were standardized to be the methane produced for 24 hours (ml/day). In addition to this, the feeding process with the syringe might have affected the daily load, and the daily load might thus have varied from day to day. These factors might have been sources of error or inaccuracy.

All the reactors achieved a COD removal of around 70% (Table 14). These numbers corresponded well with both the BMP results from batch test 1.0 (Table 12), and also with the BMP results from the DFSTR (Table 14). Even though the ideal mass balance of all reactors is 100%, it is expected that some measurement errors will occur, and it is of great difficulty to achieve a 100% value. This was further confirmed by the sludge removal results (Table 17),

which corresponded well to the COD removal of all reactors, with exception for reactor 4 that had a fairly lower TVS removal (59%) than COD removal (68%). Even though parallels were used for the TVS analysis, some measurement errors which might cause uncertainty to the values are to be expected.

Around 70% COD of the aquaculture waste from Fister Smolt and the primary sludge from IVAR SNJ was converted to methane. By assuming a total growth yield of 0.1 g COD/g COD, the non-biodegradable organics would be around 20%.

### 6.1.1 Alkalinity and pH

A rapid increase in alkalinity was observed in reactor 2 from the start of the experiment, and the alkalinity continued to increase for the remainder of the experiment, with some exceptions (Figure 14). An explanation to this trend is the ammonia release from the breakdown of organics in the aquaculture waste: at a neutral pH ammonia will obtain a proton from the dissolved carbon dioxide to form ammonium ions (Equation 5) (Gerardi, 2003). Based on this, the released ammonia will produce an alkalinity of 3.6 g HCO<sub>3</sub><sup>-</sup>/g NH<sub>3</sub> that equals to 3.6 g CaCO<sub>3</sub>/g NH<sub>4</sub><sup>+</sup>-N. The measured alkalinity and calculated alkalinity from the ammonium concentrations in the DFSTR were determined based on these calculations (Table 19).

*Table 19 Measured alkalinity and calculated alkalinity from ammonium concentrations in the DFSTR*

Substrate	Measured ammonium (g N/l)	Calculated alkalinity produced from ammonia (g/l CaCO <sub>3</sub> )	Measured alkalinity (g/l CaCO <sub>3</sub> )
Primary sludge, IVAR	0.5	1.8	1.8
Aquaculture sludge, Fister Smolt	1.6	5.8	6.1
75% primary s + 25% aquaculture waste	0.7	2.5	3.1
Aquaculture waste (pH adjusted*)	1.4	5.4	2.3*

\*The alkalinity was reduced by addition of HCl

As an effect of the ammonia release, the initial total nitrogen concentrations in the sludge samples and the amount of nitrogen released as ammonia inside the reactors will have a large impact on the total alkalinity, and as a consequence also the pH, of the reactor. In reactor 2 55% of the total ammonium was converted to ammonia (Table 15). In comparison, 48% of the total ammonium was converted to ammonia in reactor 4. These findings correspond well to the alkalinity of reactor 2 and 4 (Figure 14). The pH in the reactor is defined by the alkalinity and the carbon dioxide content of the biogas (P<sub>CO2</sub>). pH, as a function of pCO<sub>2</sub>,

estimated for the alkalinity measured in the DFSTR was presented graphically (Figure 23) using Equation 10.

$$[H^+] = \frac{pCO_2 K_H K_c}{[HCO_3^-]}$$

Equation 10 Determination of  $H^+$  concentration where  $K_H$  is Henry's law constant expressed as  $Mbar^{-1}$  and  $K_c$  is the dissociation coefficient for  $CO_2/HCO_3$ .

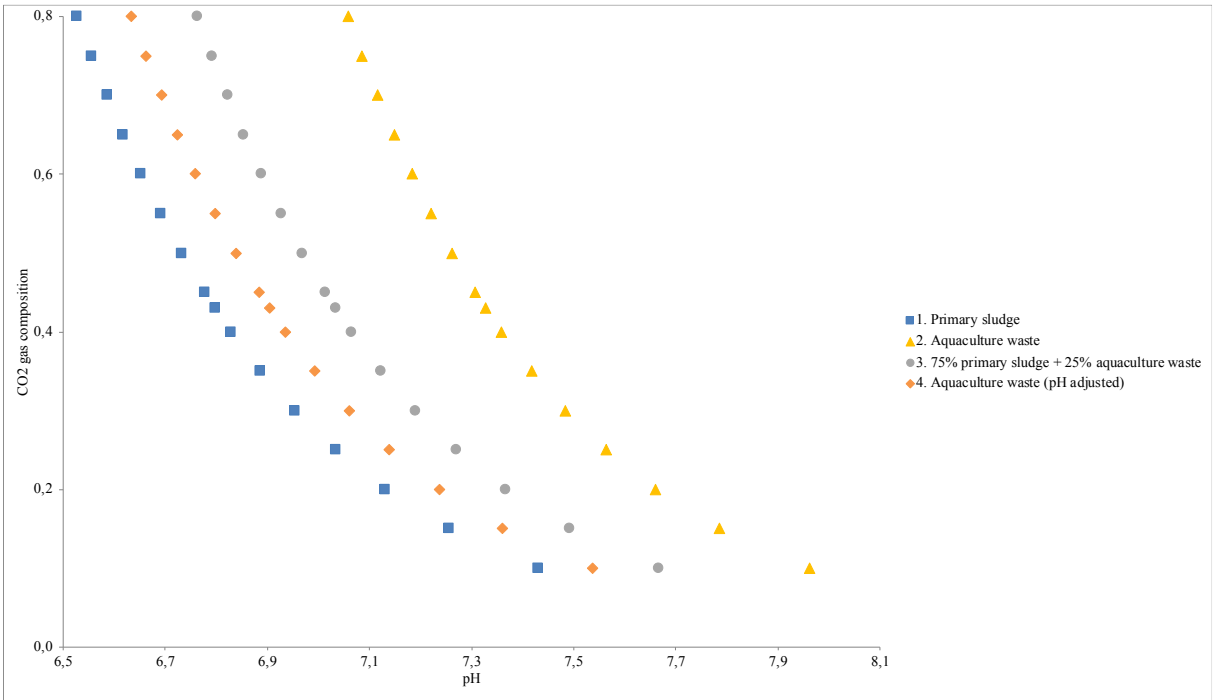

Figure 23 pH as a function of  $pCO_2$  estimated for the alkalinity in Table 19, Henry's constant of  $0.0270 M/bar$  and  $CO_2$  dissociation constant of  $4.9431 \cdot 10^{-7} M$ .

High  $pCO_2$  were observed to give a lower pH (Figure 23). The  $pCO_2$  measured in the aquaculture waste reactors 2 and 4 were much higher compared to reactor 1 and 3, which neutralized the high alkalinity and provided a relatively low pH (Table 20).

Table 20 Measured pCO<sub>2</sub>, calculated expected pH and measured overall pH in DFSTR

Substrate	Measured pCO <sub>2</sub>	Calculated expected pH	Measured average overall pH	Measured average pH for the extended performance test
Primary sludge, IVAR	0.43	6.80	6.93±0.09	
Aquaculture sludge, Fister Smolt	0.47	7.29	7.20±0.015	7.34±0.10
75% primary s + 25% aquaculture waste	0.43	7.03	7.09±0.10	
Aquaculture waste (pH adjusted*)	0.50	6.84	6.86±0.19	6.99±0.13

A higher pCO<sub>2</sub> during anaerobic digestion of aquaculture waste compared to anaerobic digestion of primary sludge was an unexpected result, as the bicarbonate production from ammonia should induce a higher content of produced carbon dioxide in the form of bicarbonate, which in turn would provide a reduction of pCO<sub>2</sub>. As this effect was not observed, it indicates that a very high bicarbonate production is needed to influence the pCO<sub>2</sub>. However, several other processes could increase the pCO<sub>2</sub>, such as the release of phosphorous and precipitation of calcium carbonate and struvite. The pCO<sub>2</sub> is also substrate specific and depends on the oxidation state of the organic carbon (Sotemann, Ristow, Wentzel, & Ekama, 2005). Thus, the reason for the relatively high pCO<sub>2</sub> for the anaerobic digestion of aquaculture waste should be further investigated. This is relevant because pCO<sub>2</sub> affects the pH of the reactor and thus also influence the nitrogen dissociation to ammonia and possibly also the inhibition of the methanogens.

## 6.2 Ammonia inhibition and operational strategies

In the extended performance test, reactor 2 and 4 had a constant ammonium concentration of around 1.6 g/l. The ammonia content however varied depending on the pH. Ammonia has been reported to be inhibiting to the methanogens by reducing the growth rate (Mirzoyan, Tal, & Gross, 2010). When this occurs VFA will accumulate and the pH will decrease and so will the concentration of ammonia. This event could be characterized as an inhibited steady state. An inhibited steady state was observed in reactor 2 when the ammonia concentration was around 50mg/l. A decrease in pH was observed at the same time, and in addition to this an increase in VFA was also observed. The VFA concentration was around 2.5 g/l when the experiment was terminated. This indicates an inhibition of the methanogens. During the inhibited steady state, it was observed that at a pH of 7.3, the system could tolerate an ammonium concentration of

1.6g/l. An estimation of ammonia was determined based on pH measurements in the DFSTR and a constant TAN of 1.6 g/l (Figure 24).

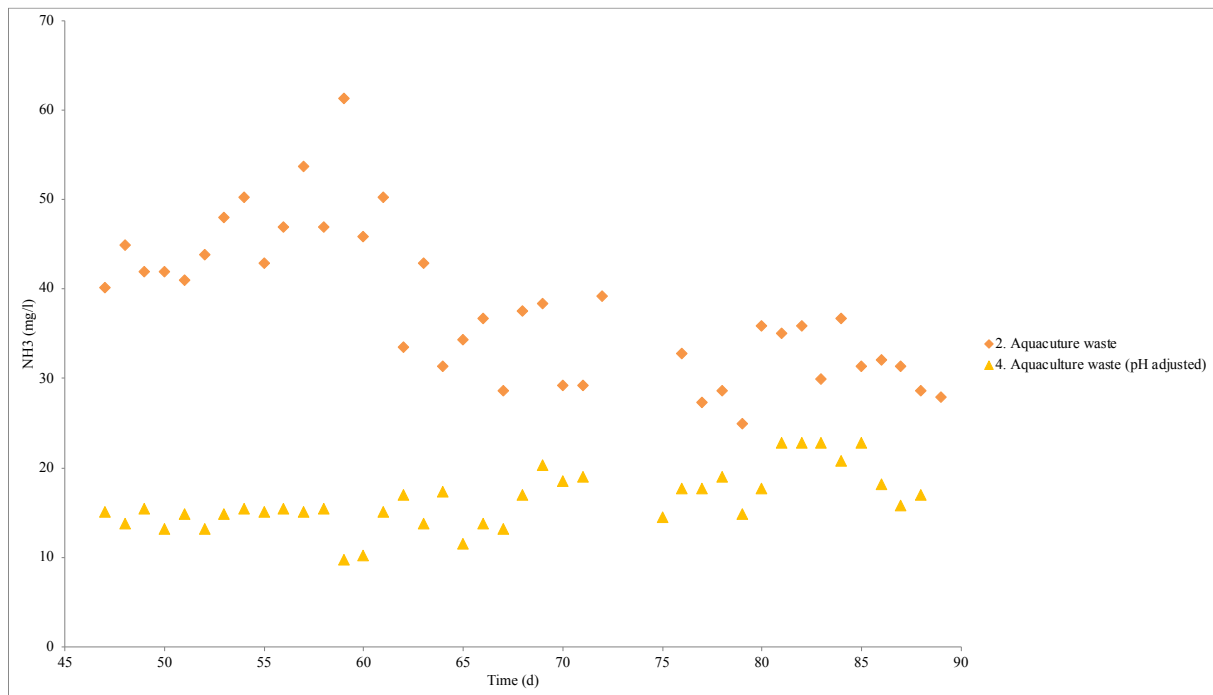

Figure 24 Estimated FAN based on pH measured in the DFSTR and a constant TAN of 1.6g/l

Ammonia induced inhibited steady states have been reported in similar experiments: in their experiment with anaerobic treatment of RAS sludge using a CSTR system with an HRT of 55-60 days Gebauer & Eikebrokk, 2006, discovered a process inhibition during the whole operation period with VFA concentrations of 18-28 g/l. However, the high protein content caused a high enough alkalinity to avoid digester failure and the experiment reached a stable pH of 7.4-7.5. They stressed that based on previous investigations (Kugelman & Van Gorder, 1991), the inhibition was most likely due to the high ammonium concentration as the concentration of unionized ammonium exceeded the reported inhibitory threshold of 55 mg (Bhattacharya & Parkin, 1989).

In their review “*Ammonia inhibition in anaerobic digestion*” Yenigun & Demirel, 2013 reported that when above threshold concentrations, FAN is an inhibitor in anaerobic digesters that might cause instability in the process which can be indicated by a decrease in biogas and methane yields. However, they also found that when the bacteria were able to gradually acclimate to the ammonia levels, the digester could operate at high concentrations of ammonia without being inhibited. They suggested that dilution of the substrate or adjustment of the



process pH could potentially increase the biogas and methane yields and to achieve a stable process. Further research should be conducted on the inhibitory threshold of ammonia.

From the results, it is possible to say that pH adjustment of the aquaculture waste from Fister Smolt has been a successful strategy for avoiding ammonia induced inhibition and to achieve a more stable process. In addition to this, diluting the aquaculture waste from Fister Smolt with primary sludge from IVAR also proved to be a successful strategy for keeping the ammonia concentration at a low level, as well as experiencing a more stable process. Though this were achieved at a 15-day STR, another possible alternative would have been to double the STR to 30 days. In such case, one would have to double the size of the reactor or halve the COD load. This is an aspect for further research.

## 7. Conclusion

Anaerobic co-digestion of aquaculture waste from Fister Smolt and municipal waste from IVAR SNJ. The biogas production, sludge removal, and ammonia inhibition has been evaluated. Some operational strategies and future perspectives were discussed. Based on the results from the experiments in this study, the following conclusions have been made:

- Batch testing of aquaculture waste from Fister Smolt (6.17% TS, 68 g/kg COD) gave a BMP of 69% in batch test 1.0 and 75% in batch test 2.0. Primary sludge from IVAR SNJ (2.32% TS, 30 g/kg COD) achieved a BMP of 72% in batch test 1.0. Co-digestion of the aquaculture waste with active sludge from IVAR SNJ (4.16% TS, 53 g/kg COD) achieved a BMP of 76% in batch test 2.0.
- Anaerobic treatment of the aquaculture waste from Fister Smolt and the primary sludge from IVAR SNJ, using a daily fed stirred tank reactor at a 15-day SRT, gave a 68-71% COD reduction and 67-70% methane yield. Co-digestion of the substrates achieved a 73% COD reduction and a methane yield of 74%.
- The results from the batch tests and the continuous daily fed stirred tank reactor showed approximately the same methane yield. Co-digestion gave an increased methane yield of 1% in batch test 2.0 and 6% in the daily fed stirred tank reactor system. Both values were regarded as too low to confirm an actual increase in the overall methane yield. No increase in methane yield were achieved during co-digestion in batch test 1.0.
- Contrary to the hypothesis of this study, the aquaculture waste from Fister Smolt and the primary sludge from IVAR SNJ had quite similar nitrogen content when compared as fractions of TVS: 0.60 and 0.51 respectively.
- Anaerobic digestion of the aquaculture waste from Fister Smolt was inhibited by ammonia to some extent when the ammonia concentration was around 50 mg/l. The system entered an inhibited steady state and at a pH of 7.3 and ammonium levels of 1.6 g/l, methane was still produced at a satisfying level. An increase in VFA concentration to 2100 mg/l reduced the ammonia concentration to 30 mg/l, as the pH was decreased. A high level of CO<sub>2</sub> in the biogas might have been involved in keeping the pH of the aquaculture waste from Fister Smolt low.

- pH adjustment of the aquaculture waste from Fister Smolt and the co-digestion of aquaculture waste from Fister Smolt with primary waste from IVAR SNJ were recognized as successful operating strategies to reduce the ammonia concentration of the systems and achieve a more stable anaerobic digestion process.
- It was shown to be possible to anaerobically digest aquaculture waste from Fister Smolt (with a total nitrogen concentration of 2.9 g/l) without pH adjustment or co-digestion with primary sludge. However, close evaluation of the nitrogen concentration was found to be an important factor in order to avoid accumulation of ammonia.
- Further research should be conducted on anaerobic treatment of aquaculture waste and anaerobic co-digestion of aquaculture waste with other organic substrates, as these processes can be highly beneficial methods for sludge stabilization and energy recovery.

## 8. References

- APHA. (1999). *Standard methods for the examination of water and wastewater* (Vol. 20 th ed.). Washington: American Public Health Association, American Water Works Association, Water Environment Federation.
- Aarhus, I., Høy, E., Fredheim, A., & Winther, U. (n.d.). *SINTEF*. Retrieved April 17, 2018, from Kartlegging av ulike teknologiske løsninger for å møte de miljømessige utfordringene i havbruksnæringen: [https://www.regjeringen.no/globalassets/upload/fkd/vedlegg/rapporter/2011/sintef\\_kartlegging\\_uliike\\_teknologiske\\_losninger2011.pdf](https://www.regjeringen.no/globalassets/upload/fkd/vedlegg/rapporter/2011/sintef_kartlegging_uliike_teknologiske_losninger2011.pdf)
- Bhattacharya, S., & Parkin, G. (1989). The effect of ammonia on methane fermentation process. *Journal Water Pollution Control Federation*, 61(1), 55-59.
- Bioprocess control. (n.d.). *Operation and Maintenance Manual*. Retrieved April 30, 2018, from <http://www.bioprocesscontrol.com/media/1511/bioprocess-control-manual-ampts-ii-ampts-ii-light.pdf>
- Board on Agriculture, National Research Council. (1993). *Nutrient Requirements of Fish*. Washington, D.C: National Academy Press.
- Chen, S., Coffin, D., & Malone, R. (1997). Sludge production and management for recirculating aquaculture systems. *J. World Aquacult. Soc.*, 28, 303-315.
- Clesceri, L., Greenberg, A., & Eaton, A. (1998). *Standard methods for the examination of water and wastewater*. Washington: American Public Health Association.
- Couturier, M., Trofimencoff, T., Buil, J., & Conroy, J. (2009). Solids removal at a recirculation salmon-smolt farm. *Aquaculture Engineering*, 41, 71-77.
- Estevez, M., Sapci, Z., Linjordet, R., & Morken, J. (2014). Incorporation of fish by-product into the semi-continuous anaerobic co-digestion of pre-treated lignocellulose and cow manure, with recovery of digestate's nutrients. 66.
- Fiskeridirektoratet. (2017, 10 16). *Akvakulturstatistikk (tidsserier)*. Retrieved from Laks, regnbueørret og ørret (Settefiskproduksjon): <https://www.fiskeridir.no/Akvakultur/Statistikk-akvakultur/Akvakulturstatistikk-tidsserier/Laks-regnbueoerret-og-oerret>
- Fjørtoft, K., Morken, J., Hansen, J., & Brised, T. (2014). Methane production and energy evaluation of a farm scaled biogas plant in cold climate area. 169, 72-29.
- Food and Agriculture Organization of the United Nations. (n.d.). *The nutrition and feeding of farmed fish and shrimp - a training manual*. Retrieved April 17, 2018, from The essential nutrients: <http://www.fao.org/docrep/field/003/ab470e/ab470e06.htm#ref6.1>
- Gallert, C., Bauer, S., & Winter, J. (1998). Effect of ammonia on the anaerobic degradation of protein by a mesophilic and thermophilic biowaste population. *Applied Microbiol. Biotechnol.*, 50, 495-501.
- Gebauer, R. (2004). Mesophilic anaerobic treatment of sludge from saline fish farm effluents with biogas production. *Bioresour. Technol.*, 93, 155-167.
- Gebauer, R., & Eikebrokk, B. (2006). Mesophilic anaerobic treatment of sludge from salmon smolt hatching. *Bioresource Technology* 97, 2389-2401.
- Gerardi, M. (2003). The Microbiology of Anaerobic Digesters. In G. Bitton, *Wastewater Microbiology* (pp. 99-105). Hoboken, New Jersey: John Wiley & Sons, Inc.
- Gueterbock, R., & Sangosanya, B. (n.d.). *E&T Energy and Power Hub*. Retrieved April 15, 2018, from Developing on-site anaerobic digestion for smaller businesses in the food and drink sector : <https://energyhub.theiet.org/users/61586-richard-gueterbock/posts/19556-developing-on-site-anaerobic-digestion-for-smaller-businesses-in-the-food-and-drink-sector>

- Helfrich, L., & Libey, G. (n.d.). *Department of Fisheries and Wildlife Sciences*. Retrieved April 17, 2018, from Virginia Tech: <http://fisheries.tamu.edu/files/2013/09/Fish-Farming-in-Recirculating-Aquaculture-Systems-RAS.pdf>
- Henze, M., van Loosdrecht, M., Ekama, G., & Brdjanovic, D. (2008). *Biological wastewater treatment : Principles, modelling and design*. London, UK: IWA Publishing.
- Khater, E.-S., Samir, A., Bahnasawy, A., & Montasser, A. (n.d.). *Solids removal in a recirculating aquaculture system*. Moshtohor: Agric.eng.dept. Faculty of Agric., Benha University.
- Klima- og miljødepartementet. (n.d.). *Regjeringen (plan og strategi)*. Retrieved April 12, 2018, from Nasjonal tverrsektoriell biogasstrategi: <https://www.regjeringen.no/no/dokumenter/Nasjonal-tverrsektoriell-biogasstrategi/id2005701/>
- Koskela, J., Pirhonen, J., & Jobling, M. (1997). Effect of low temperature on feed intake, growth rate and body composition of juvenile Baltic salmon. *Aquaculture International*, 5(6), 479-488.
- Kristensen, T., Åtland, Å., Rosten, T., Urke, H., & Rosseland, B. (2009). Important influent-water quality parameters at freshwater production sites in two salmon producing countries. *Aquaculture Engineering*(41), 53-59.
- Kugelman, I., & Van Gorder, S. (1991, April 4-6). Water and energy recycling in closed aquaculture systems. *Engineering Aspects of Intensive Aquaculture*(49), pp. 80-87.
- Kunz, A., & Mukhtar, S. (2016). Hydrophobic membrane technology for ammonia extraction from wastewaters. *Eng.Agric.*, 2, 377-386.
- Lahav, O., & Loewenthal, R. (2000). Measurement of VFA in anaerobic digestion: The five-point titration method revisited. 26(0378-4738).
- Lanari, D., & Franci, C. (1998). Biogas production from solid wastes removed from fish farm effluents. *Aquat.Living Resour.*, 11, 289-295.
- Matias del Campo, L., Ibarra, P., Guitierrez, X., & Takle, H. (2010). *Utilization of sludge from recirculation aquaculture systems*. Tromsø: Nofima.
- Mattilsynet. (n.d.). *Vannkvalitet og vannbehandling i settefiskanlegg*. Retrieved May 2018, from Nasjonalt tilsynsprosjekt 2012-2014: [https://www.mattilsynet.no/fisk\\_og\\_akvakultur/akvakultur/drift\\_av\\_akvakulturanlegg/sluttrapport\\_vannkvalitet\\_og\\_vannbehandling\\_i\\_settefiskanlegg\\_2014.17293/binary/Sluttrapport:%20Vannkvalitet%20og%20vannbehandling%20i%20settefiskanlegg%202014](https://www.mattilsynet.no/fisk_og_akvakultur/akvakultur/drift_av_akvakulturanlegg/sluttrapport_vannkvalitet_og_vannbehandling_i_settefiskanlegg_2014.17293/binary/Sluttrapport:%20Vannkvalitet%20og%20vannbehandling%20i%20settefiskanlegg%202014)
- Mirzoyan, N. (2009). *Waste treatment for brackish water recirculated aquaculture systems: reduction of organic load followed by methane production*. Beer Sheva, Israel: Ben Gurion University of the Negev.
- Mirzoyan, N., Parnes, S., Singer, A., Tal, Y., Sowers, K., & Gross, A. (2008). Quality of brackish aquaculture sludge and its suitability for anaerobic digestion and methane production in an upflow anaerobic sludge blanket (UASB) reactor. *Aquaculture*, 35-41.
- Mirzoyan, N., Tal, Y., & Gross, A. (2010). Anaerobic digestion of sludge from intensive recirculating aquaculture systems: Review. 306(1-4), 1-6.
- Mugg, J., Serrano, A., Liberti, A., & Rice, M. (1991). *Aquaculture Effluents: A Guide for Water Quality Regulators and Aquaculturists*. North Dartmouth, Massachusetts: Aquaculture Center, University of Massachusetts Dartmouth.
- Piedrahita, R. (2003). Reducing the potential environmental impact of tank aquaculture effluents through intensification and recirculation. *Aquaculture*, 226, 35-44.

- Polizzi, C., Alatrisme-Mondragon, F., & Munz, G. (2018). The role of organic load and ammonia inhibition in anaerobic digestion of tannery fleshing. *Water Resources and Industry*, 19, 25-34.
- Rakotonomenjanahary, R. (2017). *Biogas potential of municipal sludge, industrial waste, livestock manure and preliminary study of Røysland farm biogas plant*. Faculty of Science and Technology. Stavanger: University of Stavanger.
- Rubin. (2012). *Statistikk (Varestrøm)*. Retrieved April 12, 2018, from Analysis of flows in aquaculture:  
[http://www.rubin.no/images/files/documents/varestrm\\_2011\\_nettsversjon1.pdf](http://www.rubin.no/images/files/documents/varestrm_2011_nettsversjon1.pdf)
- Sharrer, M., Tal, Y., Ferrier, D., Hankins, J., & Summerfelt, S. (2007). Membrane biological reactor treatment of a saline backwash flow from a recirculating aquaculture system. *Aquacult. Eng.*, 36, 159-176.
- Siddiqui, S. (2003). Wastewater treatment technology in aquaculture. *World Aquaculture*, 49-52.
- Solli, L., Sørheim, O., & Briseid, R. (2014). Effects of a gradually increased load of fish waste silage in co-digestion with cow manure on methane production. 34, 1553-1559.
- Sotemann, S., Ristow, N., Wentzel, M., & Ekama, G. (2005). A steady state model for anaerobic digestion of sewage sludges. *Water SA*, 31(4), 511-528.
- Tal, Y., Schreier, H., Sowers, K., Stubblefield, J., Place, A., & Zohar, Y. (2009). Environmentally sustainable land-based marine aquaculture. *Aquaculture*, 286, 28-35.
- The University of Tennessee, Knoxville . (n.d.). *WFS 493/556 Recirculation Aquaculture*. Retrieved April 17, 2018, from Solid Waste: <http://web.utk.edu/~rstrange/wfs556/>
- Timmons, M., & Ebeling, J. (2007). *Recirculating Aquaculture*. Ithaca, NY: Cayuga Aqua Ventures.
- Vaccari, D., Strom, P., & Alleman, J. (2006). *Environmental Biology for Engineers and Scientists*. Hoboken, New Jersey: John Wiley & Sons.
- Wellinger, A., Murphy, J., & Baxter, D. (2013). *The Biogas Handbook* (Vol. 52). Oxford : Elsevier Science & Technology.
- Wiese, K., & Kvenvolden, K. (1992). The future of energy gases (Introduction to Microbial and Thermal Methane). Denver, CO: U.S Geological Survey.
- Wold, A. (2017). *Anaerobic slop water treatment (impact of high salt concentrations)*. Stavanger: Faculty of Science and Technology, Department of Mathematics and Natural Science, University of Stavanger.
- Yenigun, O., & Demirel, B. (2013). Ammonia inhibition in anaerobic digestion: A review. *Process Biochemistry*, 901-909.
- Zeikus, J., & Winfrey, M. (1976). Temperature limitation of methanogenesis in aquatic sediments. *Applied and Environmental Microbiology*(31(1)), 99-107.
- Zhou, X., Wang, Q., & Jiang, G. (2015). Enhancing methane production from waste activated sludge using a novel indigenous iron activated peroxidation pre-treatment process. *Bioresource Technology*, 267-271.