



Universitetet  
i Stavanger

**FACULTY OF SCIENCE AND TECHNOLOGY**

## **MASTER'S THESIS**

Study programme/specialisation: Petroleum Engineering/ Well Engineering and Drilling Technology	Spring / Autumn semester, 20.18..  Open/Confidential
Author: Ida Morberg Sommernes & Elisabeth Vik	..... (signature of author)
Programme coordinator:  Supervisor(s): Faculty supervisor: Kjell Kåre Fjelde External supervisor: Thorbjørn Martin Kaland	
Title of master's thesis:  An Overview and Discussion of MPD Systems used in Offshore Operations	
Credits: 30	
Keywords: Managed Pressure Drilling Conventional Drilling Challenges Constant Bottomhole Pressure Controlled Mud Level Pressurized Mud Cap Drilling	Number of pages: .....115.....  + supplemental material/other: .....1.....  Stavanger, ...12.06.2018..... date/year

## Acknowledgement

We would like to thank professor Kjell Kåre Fjelde, our academic supervisor at the University of Stavanger. He has been of great assistance with this thesis, not only has he helped us academically by sharing his knowledge. He has also, with his enthusiasm and encouragement, given us confidence and motivation.

Our external supervisor at Halliburton, Thorbjørn Kaland, has also been a great help. He has, with his vast network, provided us with valuable information from the industry. We were lucky enough to be invited to the SPE Norway One Day Seminar in Bergen, which he was in the committee of. This was a very educational and pleasurable experience.

It would have been difficult to write this thesis without their advice, guidance and availability throughout the process.

We would also like to thank Eric Claudey from Enhanced Drilling for giving us information and helping us with Chapter 3.

## Summary

Globally, established fields are reaching maturity and easily accessible reserves have already been exploited. The remaining reserves are generally more difficult to drill and attempting to drill them using conventional methods may cause problems in form of increased NPT, safety risks as well as increased costs. Due to the problems these wells face, exploring them may be uneconomic as the expenses may absorb the profits. This development calls for a new and improved drilling technique.

There are several types of problematic formations and there is no single technique that can address all the challenges that arise from drilling in such formations. Therefore, several different methods have been developed to mitigate these challenges and collectively these techniques are referred to as *Managed Pressure Drilling (MPD)*.

This thesis explains how the different MPD methods work, what equipment is needed and in which cases the methods can provide more productive drilling. The technologies that will be discussed are called; Constant Bottom Hole Pressure drilling, Controlled Mud Level drilling and Pressurized Mud Cap Drilling. As the name Manage Pressure Drilling implies, the key principle for all these methods is to manage the pressure.

The petroleum industry can, in many ways, be considered conservative and many companies are reluctant to test new drilling technologies. In some cases, it can be rewarding to give new and untried methods such as MPD a chance. However, MPD cannot be used on every well to increase efficiency, there must be an actual need for this technology for it to be profitable.

“MPD – More Productive Drilling” [58]

## Table of Contents

<b>Acknowledgement</b> .....	<b>2</b>
<b>Summary</b> .....	<b>3</b>
<b>Table of Figures</b> .....	<b>7</b>
<b>Nomenclature</b> .....	<b>9</b>
<b>Introduction</b> .....	<b>13</b>
<b>Chapter 1 – Conventional Drilling Challenges and MPD Definition</b> .....	<b>14</b>
<b>1.1 Conventional Drilling</b> .....	<b>15</b>
<b>1.2 MPD Definition</b> .....	<b>16</b>
<b>1.3 Advantages of MPD</b> .....	<b>16</b>
1.3.1 Pipe Sticking.....	17
1.3.2 Lost Circulation.....	18
1.3.3 Kick/Influx Detection.....	19
1.3.4 Number of Casing Sections.....	19
<b>1.4 Disadvantages of MPD</b> .....	<b>20</b>
<b>1.5 The Two Basic Approaches</b> .....	<b>20</b>
1.5.1 Reactive MPD.....	20
1.5.2 Proactive MPD.....	20
<b>1.6 MPD Methods</b> .....	<b>21</b>
<b>Chapter 2 – Constant Bottom Hole Pressure Method (CBHP)</b> .....	<b>22</b>
<b>2.1 Historic Development of the CBHP Technique</b> .....	<b>22</b>
<b>2.2 Pressure Control Principles of SBP CBHP</b> .....	<b>23</b>
<b>2.3 Surface Backpressure (SBP)</b> .....	<b>26</b>
<b>2.4 Continuous Circulation Method (CCM)</b> .....	<b>27</b>
<b>2.5 Equipment</b> .....	<b>29</b>
2.5.1 Rotating Control Device (RCD).....	30
2.5.2 Choke.....	31
2.5.3 Drill-Pipe Non-Return Valves (NRV).....	32
2.5.4 Coriolis Flowmeter.....	33
2.5.5 Multiphase Separator.....	33
2.5.6 Downhole Annular Valves (DHAV) and Casing Isolation Valve (CIV).....	33
2.5.7 Backpressure Pump (BPP).....	34
2.5.8 Rig Pump Diverter (RPD).....	34
2.5.9 GeoBalance® Optimized Pressure Drilling Services.....	36
2.5.10 Continuous Circulation Valve.....	37
2.5.11 Continuous Circulation System (CCS).....	38
<b>2.6 Barriers</b> .....	<b>39</b>
<b>2.7 Well Control</b> .....	<b>40</b>

2.7.1 IME (Influx Management Envelope).....	42
2.7.2 NORSOK Standard .....	43
2.7.3 Oil Based Mud vs. Water Based Mud .....	44
<b>2.8 CBHP Applied from Floaters .....</b>	<b>45</b>
<b>2.9 Case Studies .....</b>	<b>47</b>
2.9.1 Continuous Circulation Method: E-CD™.....	47
2.9.2 Surface Backpressure + Continuous Circulation Method: ENBD™.....	48
2.9.3 Surface Backpressure .....	49
2.9.4 Surface Backpressure .....	49
2.9.5 Surface Backpressure + Continuous Circulation Method.....	50
<b>2.10 Challenges and Benefits.....</b>	<b>51</b>
2.10.1 Handling Tight Drilling Margins and Unknown Formation Pressures.....	51
2.10.2 Handling ECD Issues & Wellbore Stability.....	52
2.10.3 Improved Well Control.....	53
2.10.4 Saving Casing Strings .....	53
2.10.5 Reduced NPT .....	53
2.10.6 Challenges.....	53
<b>Chapter 3 – Controlled Mud Level (CML).....</b>	<b>55</b>
<b>3.1 Dual Gradient Drilling (DGD) .....</b>	<b>55</b>
<b>3.1.1 Historic Development.....</b>	<b>57</b>
<b>3.1.2 Principle of DGD .....</b>	<b>58</b>
<b>3.2 Equipment .....</b>	<b>59</b>
3.2.1 Subsea Equipment.....	60
3.2.2 Surface Equipment.....	61
<b>3.3 Dynamics of the System.....</b>	<b>62</b>
<b>3.4 Pressure Control Principle.....</b>	<b>64</b>
3.4.1 The s.g. vs. Depth Plots.....	66
3.4.2 The Bar vs. Depth Plots .....	67
<b>3.5 Barriers .....</b>	<b>69</b>
<b>3.6 Well Control .....</b>	<b>70</b>
3.6.1 Kick Detection.....	70
3.6.2 U-Tube Effect and Fingerprinting .....	72
3.6.3 Gas Kick Migration Velocity.....	73
<b>3.7 Controlled Mud Cap Drilling (CMCD).....</b>	<b>74</b>
<b>3.8 Case Studies .....</b>	<b>75</b>
3.8.1 Offshore Cuba, Gulf of Mexico .....	75
3.8.2 Statoil, Norwegian Continental Shelf and Gulf of Mexico .....	76
3.8.3 Lundin, Barents Sea .....	77
<b>3.9 Challenges and Benefits .....</b>	<b>79</b>
3.9.1 Compensate for the ECD Effect .....	79
3.9.2 Early Kick Detection .....	79
3.9.3 No Need to Modify the Riser System .....	80

3.9.4 Possible to Drill Longer Hole Sections .....	80
3.9.5 Avoiding Mud Losses .....	80
3.9.6 Riser and Trip Margin.....	80
3.9.7 Challenges.....	81
<b>Chapter 4 – Pressurized Mud Cap Drilling (PMCD) .....</b>	<b>82</b>
<b>4.1 Historic Development of PMCD .....</b>	<b>83</b>
<b>4.2 Pressure Control Principles of PMCD.....</b>	<b>85</b>
4.2.1 Pressure Control Example.....	86
<b>4.3 Equipment .....</b>	<b>89</b>
<b>4.4 Barriers .....</b>	<b>90</b>
<b>4.5 Well Control .....</b>	<b>90</b>
<b>4.6 Case History .....</b>	<b>91</b>
4.6.1 Offshore Sarawak, Malaysia.....	91
4.6.2 Onshore South Sumatra, Indonesia.....	92
4.6.3 Offshore Santos, Brazil .....	93
<b>4.7 Challenges and Benefits .....</b>	<b>94</b>
4.7.1 Handling fractured formations .....	94
4.7.2 Cost .....	95
4.7.3 Safety.....	96
4.7.4 Fluids and Logistics.....	96
<b>Chapter 5 – Discussion.....</b>	<b>97</b>
<b>5.1 Applications .....</b>	<b>97</b>
5.1.1 Constant Bottom Hole Pressure.....	97
5.1.2 Controlled Mud Level.....	98
5.1.3 Pressurized Mud Cap Drilling.....	99
<b>5.2 Systematic Overview of Challenges and Benefits .....</b>	<b>100</b>
<b>Conclusion .....</b>	<b>103</b>
<b>Table of References.....</b>	<b>105</b>
<b>Appendix – Job Distribution.....</b>	<b>116</b>

## Table of Figures

### Chapter 1

Figure 1. 1 Drilling Windows, Inspired by [74] .....	14
Figure 1. 2 MPD Variants Overview, Inspired by [64] .....	21

### Chapter 2

Figure 2. 1 Pressure vs. TVD, High Mud Weight .....	24
Figure 2. 2 Pressure vs. TVD, Low Mud Weight .....	25
Figure 2. 3 Illustration of SBP MPD Set-Up, Inspired by [22] .....	26
Figure 2. 4 Continuous Circulation Illustration, Inspired by [74] .....	28
Figure 2. 5 Tool Configuration.....	29
Figure 2. 6 Marine Sentry RCD 3000 [19].....	30
Figure 2. 7 Choke Manifold [19].....	32
Figure 2. 8 Coriolis Flowmeter [20].....	33
Figure 2. 9 RPD 800 [14].....	35
Figure 2. 10 Tool Configuration with RPD .....	36
Figure 2. 11 Continuous Circulation Flow Illustration.....	37
Figure 2. 12 E-CD™- Circulating Sub [101] and Diversion Manifold [102] .....	38
Figure 2. 13 Well Barrier Schematic with Underbalanced Fluid [12].....	40
Figure 2. 14 Influx Management Envelope [57].....	42
Figure 2. 15 Gas Rate Out vs. Time for WBM and OBM [56] .....	44
Figure 2. 16 Choke Pressure vs. Time for WBM and OBM [56] .....	45
Figure 2. 17 Pit Gain vs. Time for WBM and OBM [56].....	45
Figure 2. 18 BTR RCD, Inspired by [64].....	46

### Chapter 3

Figure 3. 1 Static and Dynamic Conditions for Dual and Dingle Gradient Drilling, Inspired by [74] .....	56
Figure 3. 2 Depiction of Wellbore Pressure Profile for Single and Dual Gradient Drilling, Inspired by [70].....	59
Figure 3. 3 EC-Drill Overview, Inspired by [46] .....	59
Figure 3. 4 Subsea Pump Module Placed in Launch System Prior to Docking to Riser [76] .....	60

Figure 3. 5 Modified Riser Joint, Shown with Subsea Pump Module During Interface Test [76].....	60
Figure 3. 6 Umbilical Winch and Hose Handling Platform on Deck [76].....	61
Figure 3. 7 Liquid Mud Seal [45] .....	62
Figure 3. 8 Tool Configuration CML, Inspired by [75] .....	64
Figure 3. 9 Real Data of Anonymous NCS Well Drilled in 2017 .....	65
Figure 3. 10 s.g. vs. Depth, Low MW & High Riser Level – 200 m.....	66
Figure 3. 11 s.g. vs. Depth, High MW & Low Riser Level – 500 m.....	66
Figure 3. 12 Bar vs. Depth, Low MW & High Riser Level – 200 m.....	67
Figure 3. 13 Bar vs. Depth, High MW & Low Riser Level – 500 m.....	68
Figure 3. 14 Well Barrier Schematic for CML [12].....	69
Figure 3. 15 Three Levels of Volume Control [73] .....	71
Figure 3. 16 Fingerprinting Functionality [45] .....	72
Figure 3. 17 Well Barrier Schematic for CMCD [76].....	74
Figure 3. 18 "Statoil Success Factors" [73].....	76
Figure 3. 19 Loss Reduction in Volume [106].....	77

#### **Chapter 4**

Figure 4. 1 MCD Variations and Zones [94] .....	83
Figure 4. 2 PMCD Pressure Example, Illustration 1 [99] .....	87
Figure 4. 3 PMCD Pressure Example, Illustration 2 [99] .....	88
Figure 4. 4 PMCD Equipment Configuration .....	89
Figure 4. 5 Well Barrier Elements of a PMCD Operation [97].....	90
Figure 4. 6 Bullheading Influxes, Inspired by [78].....	91



## Nomenclature

AFL – Annular Friction Loss

AFP – Annular Friction Pressure

BHA – Bottom Hole Assembly

BHP – Bottom Hole Pressure

BOP – Blow Out Preventer

BTR – Below Tension Ring

CBHP – Constant Bottom Hole Pressure

CC – Control Container

CCM – Continuous Circulation Method

CCS – Continuous Circulation System

CIV – Casing Isolation Valve

CMCD – Controlled Mud Cap Drilling

CML – Controlled Mud Level

CMS – Control & Monitoring System

DDV – Downhole Deployment Valve

DGD – Dual Gradient Drilling

DHAV – Downhole Annular Valve

DMCD – Dynamic Mud Cap Drilling

DOB – Diesel Oil Bentonite

DP – Dynamically Positioned

DSV – Drillstring Valve

ECD – Equivalent Circulating Density

E-CD - Eni Circulating Device

E-NBD - Eni Near Balance Drilling

ERD – Extended Reach Drilling

FIT – Formation Integrity Test

FMCD – Floating Mud Cap Drilling

GOM – Gulf of Mexico

GOR – Gas Oil Ratio

HHP – Hose Handling Platform

HSE – Health Safety Environmental

HPHT – High Pressure High Temperature

IADC – International Association of Drilling Contractors

ID – Inner Diameter

IME – Influx Management Envelope

JIP – Joint Industry Projects

LAM – Light Annular Mud

LCM – Lost Circulation Material

LWD – Logging While Drilling

MD – Measured Depth

MFC – Micro Flux Control

MODU – Mobile Offshore Drilling Unit

MPD – Managed Pressure Drilling

MRJ – Modified Riser Joint

MRL – Mud Return Line

MWD – Measurement While Drilling

NCS – Norwegian Continental Shelf

NPT – Non-Productive Time

NRV – Non-Return Valve

OTC – Office Tool Container

P - Pressure

P&A – Plug & Abandonment

PLC – Programmable Logic Controller

PMCD – Pressurized Mud Cap Drilling

POOH – Pull Out of Hole

PWD – Pressure While Drilling

QTV – Quick Trip Valve

RCD – Rotating Control Device

ROP – Rate of Penetration

RPD – Rig Pump Diverter

SAC – Sacrificial Drilling Fluid

SBP – Surface Backpressure

SMP – Subsea Mudlift Drilling

SPM – Subsea Pump Module

SPS – Subsea Pump Station

SS - Subsea

SW – Seawater

TD – Target Depth

TDP – Tubing Disappearing Plug

TVD – True Vertical Depth

UBD – Underbalanced Drilling

VFD – Variable Frequency Drive

WOB – Weight on Bit

## Introduction

An increasing amount of oil and gas fields are reaching maturity all over the world. Mature fields often suffer from depletion, which makes it difficult or impossible to reach the targets by drilling conventionally. Attempting to apply conventional drilling to such fields is typically very uneconomic and sometimes impossible due to the drilling problems and NPT (Non-Productive Time) which is often experienced. As the fields are maturing, most of the “easy” reserves have already been exploited and the remaining reserves may be located in challenging geological formations. This is forcing the areas of exploration to expand into deeper waters and more challenging formations, such as highly fractured carbonates, pre-salt layers and HPHT (High Pressure High Temperature). Wells in HPHT areas are often characterized by narrow drilling windows between the pore- and fracture pressures. Drilling HPHT reservoirs conventionally may require an amount of casing strings which could make drilling to TD (Target Depth) impossible or uneconomic.

MPD (Managed Pressure Drilling) makes it possible to drill the wells that are undrillable with conventional methods. This is made possible by utilizing technology which can manipulate the wellbore pressure to avoid challenges that may occur in conventional drilling projects. MPD is an umbrella term covering several types of technologies that manipulate the pressure in different ways. Each method has its own area of application and different problems that they solve.

The main objective of this thesis is to give insight into the tools and methods used to overcome issues with conventional drilling challenges. The knowledge on the subject is spread out in SPE papers, journals and text books, and a comprehensive summary of the information is missing or outdated. This thesis will collect the information needed to understand this new way of looking at drilling hydraulics, creating an encyclopedia.

The first chapter is meant to give a presentation of the drilling challenges conventional drilling may experience and MPD is defined. Chapters 2 – 4 go into detail about CBHP (Constant Bottom Hole Pressure), CML (Controlled Mud Level) and PMCD (Pressurized Mud Cap Drilling), respectively. This includes historic development, the pressure control principle, equipment, barriers, well control, challenges and benefits. In the concluding chapter the different application areas for the technologies mentioned are discussed. The Appendix contains an overview of how the work has been distributed between the two authors.

*“MPD - Make Problems Disappear”* <sup>[53]</sup>

## Chapter 1 – Conventional Drilling Challenges and MPD Definition

During drilling operations, knowledge of both the pore and fracture pressure is important. The pore pressure can be determined by petrophysical logs. A leak-off test can be performed to determine the fracture pressure. If the pressure in the well is lower or close to the formation pressure, formation fluid can start flowing into the well, which can result in a kick. Worst-case scenario, the kick gets out of control and leads to a blowout. Low wellbore pressure can also lead to formation instability and wellbore collapse, which can lead to stuck pipe. If the wellbore pressure is too high and exceeds the fracture pressure, differential sticking or formation fracturing can occur. When the margin between the pore pressure and the fracture pressure is very small, balancing the pressure in the wellbore becomes very difficult. The operating window between pore pressure and fracture pressure becomes narrow, especially in depleted reservoirs, HPHT wells and deepwater wells.

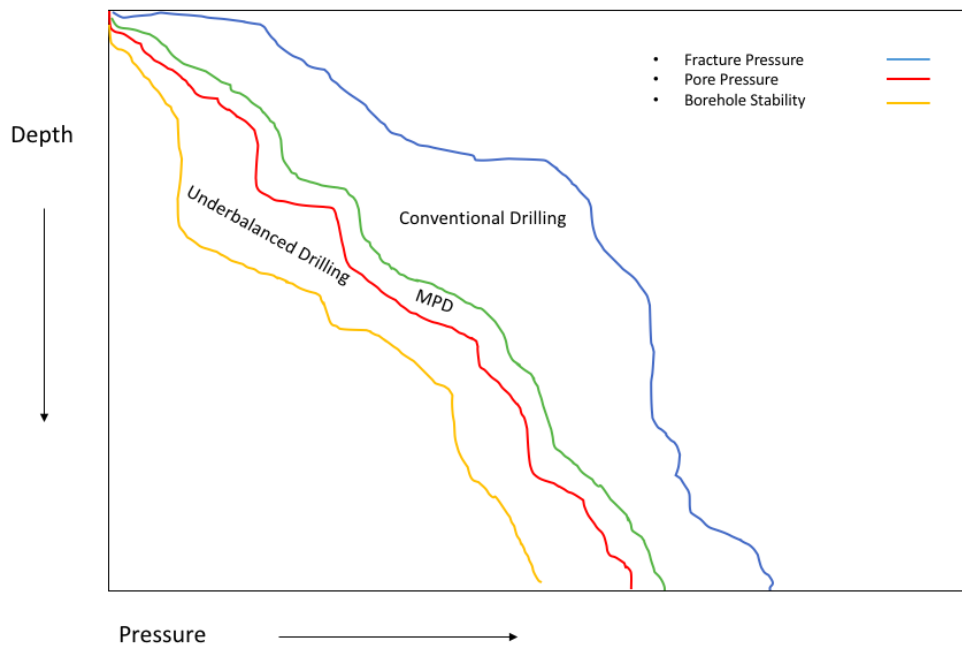

Figure 1. 1 Drilling Windows, Inspired by [74]

Even for a carefully planned well, challenges may occur while drilling. To successfully reach the target zone and for overall well-cost control, it is important to be able to understand and anticipate the drilling challenges. It is important to understand what causes problems and how to solve them. [1]

## 1.1 Conventional Drilling

In order to understand the advantages MPD can have regarding the drilling process, it is beneficial to include a short overview of the conventional drilling concepts and their limitations.

Conventional wells are usually drilled overbalanced, i.e. a condition where the wellbore pressure is greater than the pore pressure of the exposed formation. The wellbore pressure is adjusted by the mud weight and the flowrates for the pumps. When the pumps are switched off and the mud is not circulating, the well is in a static condition and the well must be overbalanced. Once the pumps start again, the system becomes dynamic and another pressure component is introduced; the annular friction pressure. The bottomhole pressure is a function of the hydrostatic pressure in the static condition. When the pumps are circulating, both the hydrostatic pressure and the annular friction pressure dynamically contribute to control the bottomhole pressure. The ECD (Equivalent Circulating Density) is another term that describes the wellbore pressure, and it is, according to Schlumberger's oilfield glossary, "*the effective density exerted by a circulating fluid against the formation that takes into account the pressure drop in the annulus above the point being considered.*" This parameter is particularly important in wells with a narrow operational window between pore- and fracture pressure in terms of avoiding losses and kicks. [15] [2]

In an open well, a kick is detected from an increase of the mud level in the pit tanks. However, a kick cannot be detected before a certain volume has entered the tank. Kick management requires that the well is being shut in during conventional drilling, this means that the drilling operation is stopped until the kick is circulated out and the mud weight is adjusted. All this NPT is very expensive and will also expose the formation to mud, which could cause additional problems and increased NPT. Today, many reservoirs have such a narrow operating window that solving one drilling problem may often create another one, which again creates another problem when solved. This becomes an expensive vicious circle of NPT. [3]

Using conventional methods, reservoirs may become unavailable when the pressure margin becomes too narrow. In addition to unavailable reserves, a project can become uneconomic from NPT. NPT, which results from kicks and lost circulation has several consequences in addition to the immediate impact. These consequences include unplanned sidetracking, additional casing strings, stuck pipe and additional mud costs. MPD is an evolving technique in the drilling industry that is used to overcome these problems. [4]

## 1.2 MPD Definition

The history of MPD goes back several decades and was used to control kicks and lost circulation from the early 1900s. In 1937, rotating control devices were put on the market, and effectively using the ECD became part of well control measures in the 1970s. Today's MPD technology utilizes the original items that were developed and combines them with new technologies. [7]

According to the IADC (International Association of Drilling Contractors), MPD is defined as:

*“An adaptive drilling process used to precisely control the annular pressure profile throughout the wellbore. The objectives are to ascertain the downhole pressure environment limits and to manage the annular hydraulic pressure profile accordingly. It is the intention of MPD to avoid continuous influx of formation fluids to the surface. Any influx incidental to the operation will be safely contained using an appropriate process.*

- 1 MPD process employs a collection of tools and techniques which may mitigate the risks and costs associated with drilling wells that have narrow downhole environmental limits, by proactively managing the annular hydraulic pressure.*
- 2 MPD may include control of backpressure, fluid density, fluid rheology, annular fluid level, circulating friction, and hole geometry, or combinations.*
- 3 MPD may allow faster corrective action to deal with observed pressure variations. The ability to dynamically control annular pressures facilitates drilling of what might otherwise be economically unattainable prospects.” (IADC, December 2011) [5]*

With MPD, one can be dealing with a closed system, which makes it easier to control the bottomhole pressure based on e.g. surface pressure adjustments. The effective BHP (Bottom Hole Pressure) can significantly and quickly be changed with fewer interruptions to drilling ahead, compared to conventional drilling. [3][6]

## 1.3 Advantages of MPD

MPD is a general description of methods for management of the wellbore pressure, and the main target is to avoid any NPT incident due to a narrow operating window. The operating window between pore pressure and fracture pressure becomes, as mentioned earlier, narrow especially in depleted reservoirs, HPHT wells and deepwater wells.



MPD solves a lot of the drilling problems contributing to NPT, which may include the following:

- Pipe sticking
- Lost circulation
- Influx detection
- Wellbore instability

MPD is also a method to reduce the number of casing strings required to reach the total depth. [7]

### 1.3.1 Pipe Sticking

There are two kinds of pipe sticking that are going to be addressed here; differential sticking and mechanical sticking. A pipe is considered stuck if it cannot be pulled out without getting damaged and without exceeding the maximum hook load allowed on the drilling rig. [1]

#### 1.3.1.1 Differential Sticking

Differential sticking is caused by the pressure difference between a permeable zone and the wellbore, forcing a portion of the drillstring to be embedded into the filter cake. The filter cake forms on the wall of the permeable formation during drilling. [7] The risk for differential sticking increases during connections and surveys, when the string is stationary.

With MPD, the differential pressure between the wellbore and the formation is smaller and the chance of differential sticking is therefore reduced.

#### 1.3.1.2 Mechanical Sticking

Mechanical sticking is caused by inadequate removal of drilled cuttings, wellbore collapse, formation swelling or key seating. [1] This problem can partly be mitigated by using MPD, as the pressure can then be kept close to constant. When the pressure is constant, the formation will not be weakened due to pressure fluctuations. Hence, the chance of mechanical sticking due to wellbore collapse will be reduced.

### Drilled Cuttings

Accumulation of excessive drilled cuttings in the annulus, caused by improper cleaning of the hole, can be a reason for mechanical sticking, especially when drilling directional wells. Large amounts of suspended

cuttings settling to the bottom when the pump is shut down can pack the BHA (Bottom Hole Assembly) and lead to pipe sticking. It is very likely that pipe sticking will occur while tripping out of a directionally drilled well, where a stationary cuttings bed is formed on the low side of the borehole. It is therefore common to flush out any cuttings bed that may be present before tripping out. This is done by circulating several times bottom up with the drill bit off bottom. An increase in torque and drag is a sign of a potential pipe sticking due to large accumulations of cuttings in the annulus.

### Borehole Instability/Collapse

Drilling in shale may cause problems. Shale can react with the mud and swell. This can lead to mechanical pipe sticking. Salt formations may cause problems as well. When drilling through salt with too low mud weight and its plastic behavior under overburden pressure, the salt has a tendency to flow into the hole. This may cause mechanical pipe sticking. Another risk of mechanical pipe sticking is drilling through coal. It is especially sensitive to pressure fluctuations, which may lead to wellbore collapse. If the mud weight is too low, it can cause the hole to collapse in all formation types. When the borehole collapses, there is a high risk of mechanical pipe sticking. If there is an increase of the circulating drillpipe pressure, an increase in torque or no fluid return to the surface, these are indications a potential pipe sticking due to borehole instability. [1]

### Key Seating

Key seating is when the drillstring is worn into the side as an additional hole into the wellbore with a smaller diameter. The diameter of this additional hole will typically have the same or similar diameter as the drillpipe. Hence, the drill collars and larger tools might become stuck when tripping out. The risk for key seating increases when drilling with a high dogleg. [8]

### 1.3.2 Lost Circulation

One of the major causes of NPT is lost circulation, which occurs when the formation fracture pressure is exceeded due to an increased drill fluid density, or due to surge pressures, when pumps start up or when tripping in. In worst case, it may occur when trying to circulate out a kick. Lost circulation is a very costly problem, both due to the NPT and the mud losses. During conventional drilling, mud loss is detected at the pits and observed losses can be associated to more than just loss to the formation. It could also be

associated to partial losses such as downhole losses, surface leaks or loss from the shakers. Hence, partial losses which occur downhole may go undetected and the appropriate actions may not be taken, e.g. decreasing pressure. As a result, a fracture downhole may be permitted to propagate, which in turn may lead to severe, or total, losses. With some MPD methods, the system is closed, and any observed loss is only associated with the formation. Even small losses can be detected early, and the corrective measures can be taken. The bottomhole pressure can be kept approximately constant, which reduces pressure fluctuations and the risk of lost circulation. In both conventional drilling and MPD, the mud weight must be maintained below the fracture pressure to prevent losses. Some MPD types enable the use of lighter drilling fluids, by applying annular backpressure during connections, making it is possible to stay below the fracture pressure even during the presence of friction. Therefore, MPD can be used as a preventative solution for lost circulation. [7] [9]

### 1.3.3 Kick/Influx Detection

A kick may occur if the formation pressure is higher than the hydrostatic annular pressure, and formation fluids are forced into the wellbore. If the formation also has high permeability and porosity, the chances for a severe kick increase. A kick may result in a blowout if it is not successfully controlled. [10]

The volume in the pits will increase when a kick is taken. In conventional drilling, a kick can be detected by monitoring the return system or if the well is still flowing after the pumps are turned off. The well is often shut in for monitoring of the wellhead pressure to be sure that a kick has actually been taken before well control actions are initiated. [11]

### 1.3.4 Number of Casing Sections

In conventional drilling, the well is drilled with a lighter drilling fluid density in the upper sections. In the lower sections, the pressure will normally become higher, caused by increased overburden and higher formation pressures. The drilling fluid density must be increased to avoid a well pressure lower than the pore pressure. When the weight is increased, problems may occur in the higher levels of the well, as the pressure might exceed the fracture pressure at this level. To solve this, a casing must be set at the depth where the mud changes to a higher density. The problem with many casing sections is reduced hole size and lower production rate.

Some methods within MPD extend the casing point and may reduce the number of casing sections. This means that the target is reached with a wider hole for completion and production, which adds economic value to the operation. The drilling cost is also reduced due to the decrease in the casings itself, cement and time associated with cementing, and running casings. [7]

#### 1.4 Disadvantages of MPD

Here are some of the disadvantages with MPD, they will be discussed further in later chapters.

- Expensive
- Advanced
- More technology causes more vulnerability
- More crew onboard

#### 1.5 The Two Basic Approaches

There are two different approaches of how to apply MPD; reactive and proactive, both will briefly be mentioned in the following.

##### 1.5.1 Reactive MPD

Reactive MPD is when MPD methods are used to mitigate drilling problems as they arise in a well that is planned to be conventionally drilled. It is sometimes described as the HSE (Health Safety Environmental) variation as it allows the driller to react safely and efficiently to drilling problems. [3]

##### 1.5.2 Proactive MPD

Proactive MPD is when MPD methods are used to precisely and actively control the annular pressure profile for the exposed wellbore. With this approach, the effectiveness of avoiding a wide range of drilling challenges, by reducing the NPT, is maximized. Proactive MPD makes it possible to drill the most operationally challenged, economically challenged and the undrillable wells. [3]

## 1.6 MPD Methods

MPD is application specific, i.e. one MPD method does not solve all problems. The following figure is an overview of the different MPD methods that will be described in this thesis.

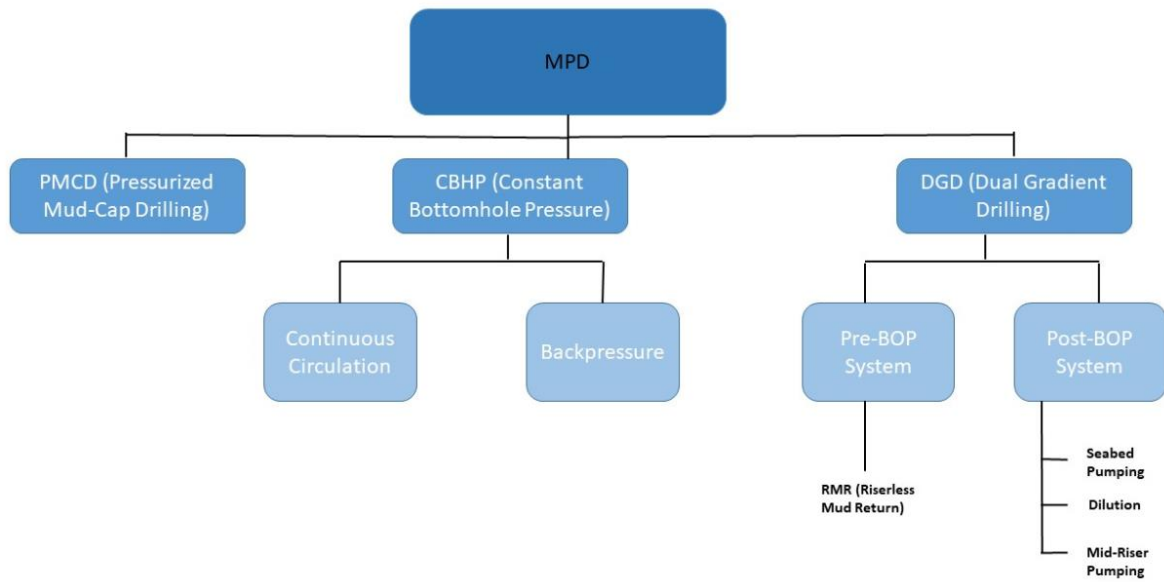

Figure 1. 2 MPD Variants Overview, Inspired by [64]

## Chapter 2 – Constant Bottom Hole Pressure Method (CBHP)

CBHP is a branch within MPD and is used world-wide, both on land rigs and offshore. This technique has a wide range of applications such as, but not limited to, exploration drilling with unknown formation pressures, HPHT wells and most importantly wells with narrow operating windows. The CBHP method is also known as “walking the line”, between the narrow pore- and fracture pressure gradients. The concept of this method is to keep the BHP constant to avoid pressure fluctuations during the drilling operation. In conventional drilling, pressure fluctuations can cause several drilling problems such as loss of circulation, influx, collapse and differentially stuck pipe. The CBHP method, to a large extent, mitigates these problems and aims to decrease excessive mud costs caused by loss of circulation, provide safer drilling operations by closely controlling the pressure, decrease rig costs and NPT by reducing collapse- and stuck pipe incidents and enable the use of fewer and deeper casing strings. [6]

CBHP can be achieved by applying SBP (Surface Backpressure) to a closed system and/or by providing continuous circulation throughout the drilling operation. Both techniques are designed to compensate for the annular pressure loss during connections and when the pumps are shut off. [21]

### 2.1 Historic Development of the CBHP Technique

The SBP MPD technique gradually evolved from UBD (Underbalanced Drilling). UBD utilizes a lot of the same equipment as MPD, but as the intention of UBD is to invite influx into the well while drilling, extra equipment is needed, for example extensive separation equipment and flaring possibilities. [51] This is why the CBHP technique is often referred to as the “original” MPD technique and was the first to be implemented in the field since it used already proven tools and technologies from UBD. [52] This specific MPD type has been practiced for decades, and the first RCD (Rotating Control Device) made for pressure control was manufactured in Fort Smith in 1968, by Weatherford. The method originated on land and has slowly worked its way to offshore operations. [53] The Continuous Circulation System was used for the first time in 2003, which will be further explained in subchapter 2.5.11.

Statoil and Halliburton introduced UBD to Norway in 2004, when they encountered drilling related challenges while drilling the C-05A well into the cap rock of the Gullfaks field. The drilling window was too narrow to be drilled conventionally, and they planned to use a full UBD-set-up and used clear brine as drilling fluid. This was based on the assumption that the produced fluid would be either oil or gas, which turned out to be incorrect. The well started producing water which caused the salt concentration

and mud weight in the active water-based fluid to decrease. The solution for this problem was to switch from UBD to MPD mode, and thereby the first application of MPD on the NCS (Norwegian Continental Shelf) was performed. This way they avoided further influx, and in turn avoided further thinning of the mud and increasing backpressure requirements. The second application of MPD on the NCS was the C-09A well drilled in 2005 which also utilized a fully underbalanced set-up. The Gullfaks reservoir is highly permeable and productive and use of UBD to reduce formation damage was therefore not needed and MPD appeared to be sufficient. [51]

The automation of the CBHP technique started in 2003 – 2006. Nogueira, Lage et al., presented the MicroFlux Control Method in 2006 [52] and D. Reitsma et al. presented the DAPC (Dynamic Annular Pressure Control) method in 2005 [54], with prototype testing starting already back in 2003. The MFC (MicroFlux® Control) method and DAPC method were tested offshore Brazil and in the North Sea (UK sector), respectively.

In 2008, Statoil planned to implement CBHP MPD from a floating drilling installation on the HPHT Kristin field. They encountered several challenges with the implementation, and the project was set on hold. [55] The same year, Transocean announced that their GSF Explorer, a DP (Dynamically Positioned) drillship, had received a contract for drilling some deepwater exploration wells in Indonesia. These wells demanded an MPD approach and the CBHP and PMCD methods were selected. This project was the first ever CBHP MPD operation to be completed from a DP floater with a BTR (Below Tension Ring) RCD worldwide. [65][66]

## 2.2 Pressure Control Principles of SBP CBHP

The principle of pressure control for the SBP CBHP technique is to keep the bottom hole pressure constant. During drilling there is a pressure difference between static and dynamic conditions which comes from the additional friction pressure that arises from fluid moving in the wellbore. In narrow drilling windows, the difference in static and dynamic pressure may cause the BHP to exceed the fracture pressure or to drop below the pore pressure, resulting in fractures or kicks. The SBP variant of CBHP applies a backpressure to the closed MPD system during connections, to counteract the pressure fluctuations. Following are the equations for bottomhole pressure, in dynamic and static conditions:

$$BHP_{stat} = P_{hyd} + SBP$$

$$BHP_{dyn} = P_{hyd} + AFP$$

$$BHP_{stat} = BHP_{dyn} \text{ when } SBP = AFP$$

Where:

- $BHP_{stat}$  = bottom hole pressure during static conditions
- $BHP_{dyn}$  = bottom hole pressure during dynamic conditions
- $P_{hyd}$  = hydrostatic pressure
- AFP = annular friction pressure
- SBP = surface backpressure

It should be noted that a surface backpressure can also be used while circulating, but this has for simplicity been omitted in the formulas above.

The following figures are graphical representations of the pressure profiles during conventional drilling and SBP MPD:

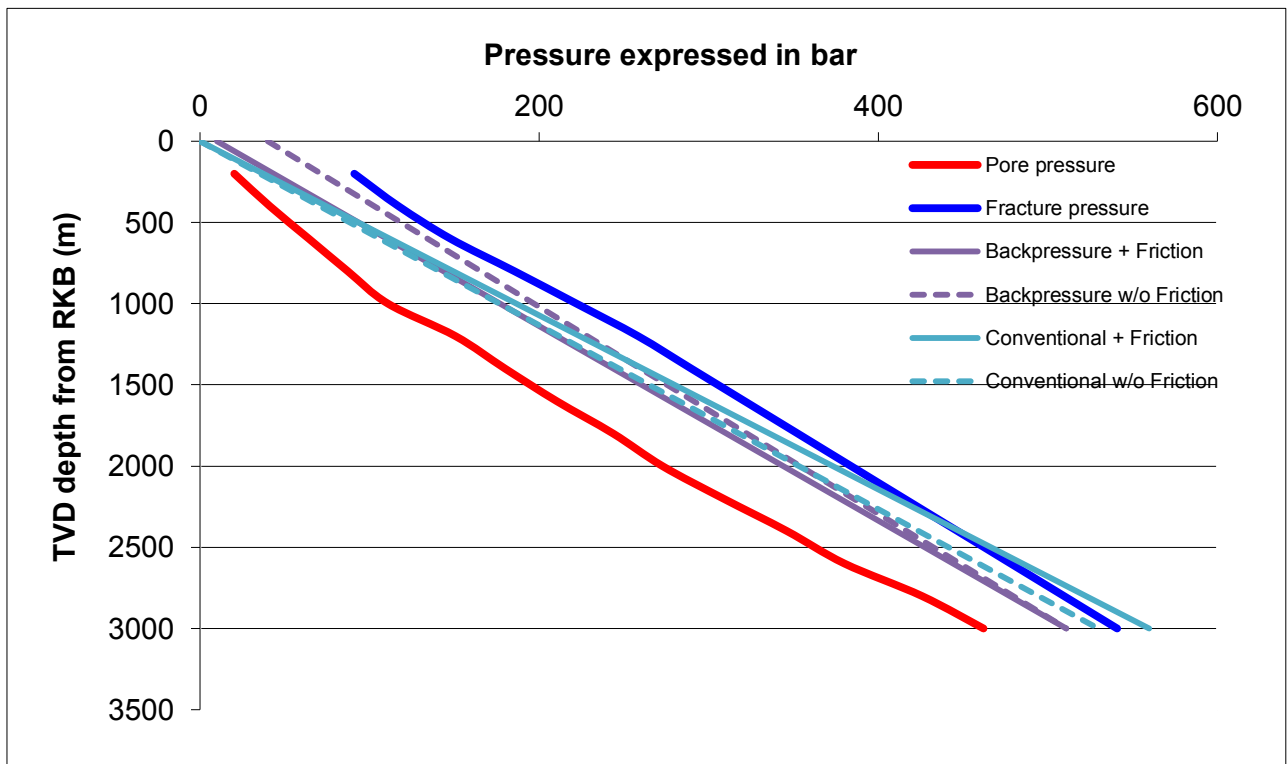

Figure 2. 1 Pressure vs. TVD, High Mud Weight



In this example, a mud weight of 1.8 s.g. is used for the conventional case and 1.6 s.g. for the backpressure case. Applying SBP allows a lower mud weight to be used, which gives more room with regards to adjusting the pressure with choke control. The backpressure being applied in this case is 10 bar during circulation and 40 bar for the static condition. The graph shows how for the conventional system, the BHP exceeds the fracture pressure towards the bottom of the hole once friction is added to the system. With backpressure applied, the BHP remains constant at 3000 m, because the backpressure is counteracting the loss of friction during connections. The gap between the top of the backpressure curves represents the amount of backpressure being applied. This method therefore allows the pressure to be held constant and enables drilling in narrow pressure windows.

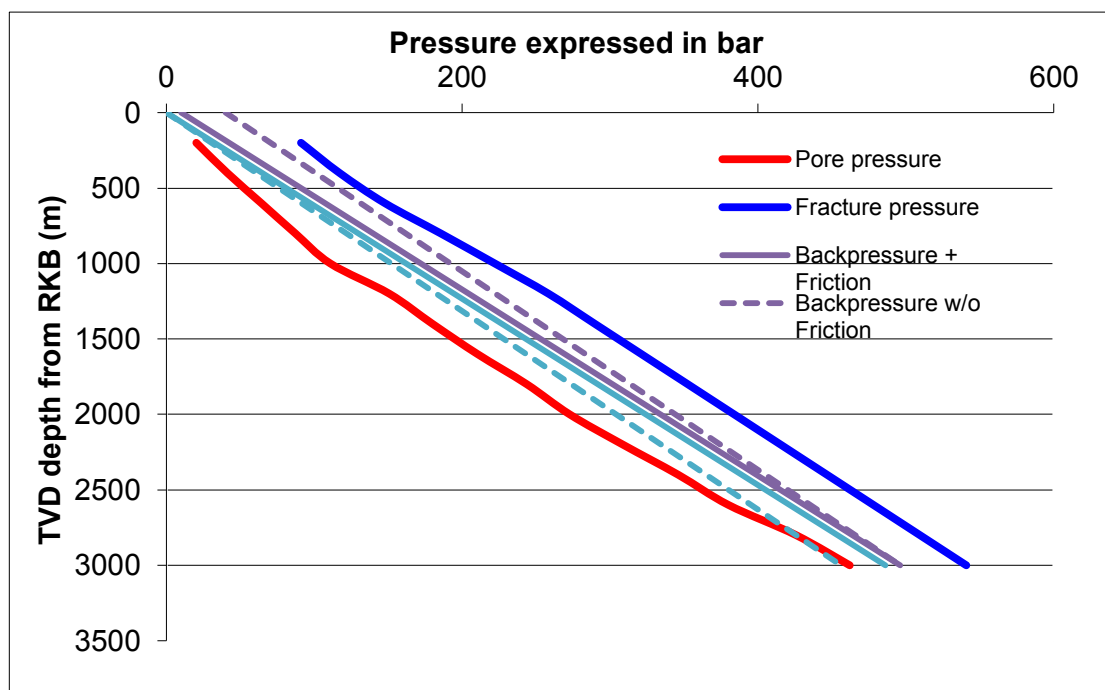

Figure 2. 2 Pressure vs. TVD, Low Mud Weight

In the next example, Fig 2.2., the same amounts of backpressure are applied, but a mud weight of 1.55 s.g. is used for both the conventional and the MPD case. In the conventional scenario, the BHP drops below the pore pressure during connections when there is no annular friction pressure present, which may cause a kick. However, while still using the same MW, the BHP is kept safe inside the drilling window by applying backpressure to counteract the loss of frictional pressure during connections. It can therefore be seen how MPD enables the use of lower mud weights.

## 2.3 Surface Backpressure (SBP)

SBP is the most common MPD variant and it can be used either by itself, or in combination with other MPD techniques. [22] The IADC has the following definition for SBP:

*“A managed pressure drilling technique used to actively apply a pressure to obtain a target pressure at a selected point in the wellbore during all drilling operations (drilling, connections, tripping, etc.).”* [23]

As mentioned in the previous subchapter, the concept of this method is to control the BHP by applying backpressure to the well during connections. The increase in backpressure applied is equivalent to the annular friction pressure which ceases during static conditions. The well is often hydrostatically underbalanced, such that the friction pressure contribution, or backpressure contribution, makes the well only slightly overbalanced. This means that the pressure in the well is at, or slightly above, the formation pressure in the surrounding area. The applied backpressure is often around 14-20 bar, which is well below the RCDs pressure ratings. If the need for backpressure increases, the mud density is often increased in order to keep the backpressure within the pressure limits of the RCD. [24]

The process of SBP can be divided in two; estimating the BHP and controlling SBP to maintain constant BHP. PWD (Pressure While Drilling) provides BHP measurements while drilling, but one cannot depend on these measurements alone due to slow transmission rates and possible tool failures. Therefore, a hydraulic model is introduced in order to provide real-time estimation of the BHP. When available, the PWD measurements go into the hydraulic model and are used to calibrate the estimates. When PWD measurements are unavailable, for instance during connections or during low flow rates, when the transmission of the measurements is not possible, the model runs based solely on surface parameters. [25] Based

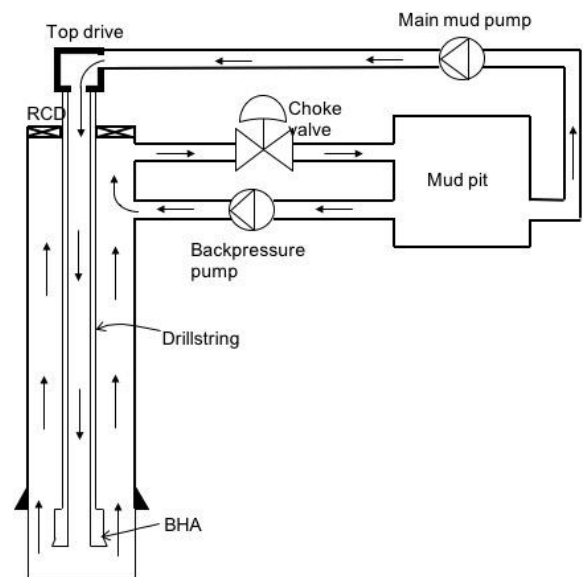

Figure 2. 3 Illustration of SBP MPD Set-Up, Inspired by [22]

on these measurements and estimates, the required SBP in order to maintain constant BHP, is calculated. The SBP is applied to the well by controlling the chokes, which can be done either manually or automatically. Today, automatic choke control is the most common and preferred method as it has a faster response time, higher reliability, and eliminates the possibility of human error. Therefore, the BHP can be adjusted almost instantaneously, providing more accurate pressure control. [22]

The following technologies can be used to achieve backpressure: [26]

- Dynamic Annular Pressure Control (DAPC) – Shell
- DAPC with modified choke manifold
- DAPC without BP pump
- MPD system without Coriolis flow meter
- MPD system with Rig Pump Diverter (RPD) – Halliburton
- MicroFlux® Control System (MFC) – Weatherford
- MPowerD™ – National Oilwell Varco

The different vendors have different means to the same end. The MicroFlux® Control System from Weatherford, for example, looks at the flow in and out and evaluates the need for intervention from these readings. A difference between inlet and outlet will indicate a gain or loss situation and the need to adjust pressures. [84] The Halliburton system however, utilizes downhole pressure sensors and compares the pressure readings with the target pressure. If the sensor reading and the target pressure differs, the pressure is adjusted accordingly. [19]

## 2.4 Continuous Circulation Method (CCM)

Continuous circulation enables drilling operations to proceed with no circulation interruptions, even during connections. The annular friction pressure is kept constant at all times and pressure fluctuations due to the ECD are therefore removed. [21] In addition to keeping the BHP constant, the continuous flow helps maintaining fluid rheology and temperature, and enables continuous hole cleaning. The continuous circulation approach is often used in combination with SBP and during conventional drilling. [19] The IADC has the following definition for the CCM:

*“An MPD technique used to maintain flow down the drill pipe while making a connection, thereby maintaining equivalent circulating density (ECD) and thus keeping a constant pressure profile in well annulus to prevent an influx of formation fluids or potential hole collapse due to instability.” [27]*

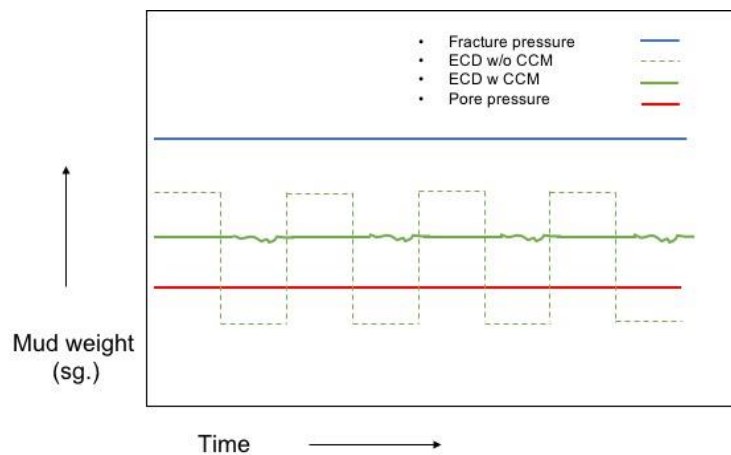

Figure 2. 4 Continuous Circulation Illustration, Inspired by [74]

There are two main approaches on how to obtain continuous circulation; CCS (Continuous Circulation System) and CCV (Continuous Circulation Valve). These technologies have some differences regarding reliability, set-up and rig footprint. The CCS, for instance, is a large piece of equipment and consequently has a large rig footprint.

Following are some of the continuous circulation technologies available:

- E-CD™ (Eni Circulating Device) - Eni/Halliburton [19]
- E-NBD™ (Eni Near Balance Drilling) - Eni/Halliburton [28]
- SteadyState™ - Weatherford [29]

## 2.5 Equipment

The illustration below is a simplified process flow diagram that shows how the various tools and equipment is tied together to form the SBP MPD system.

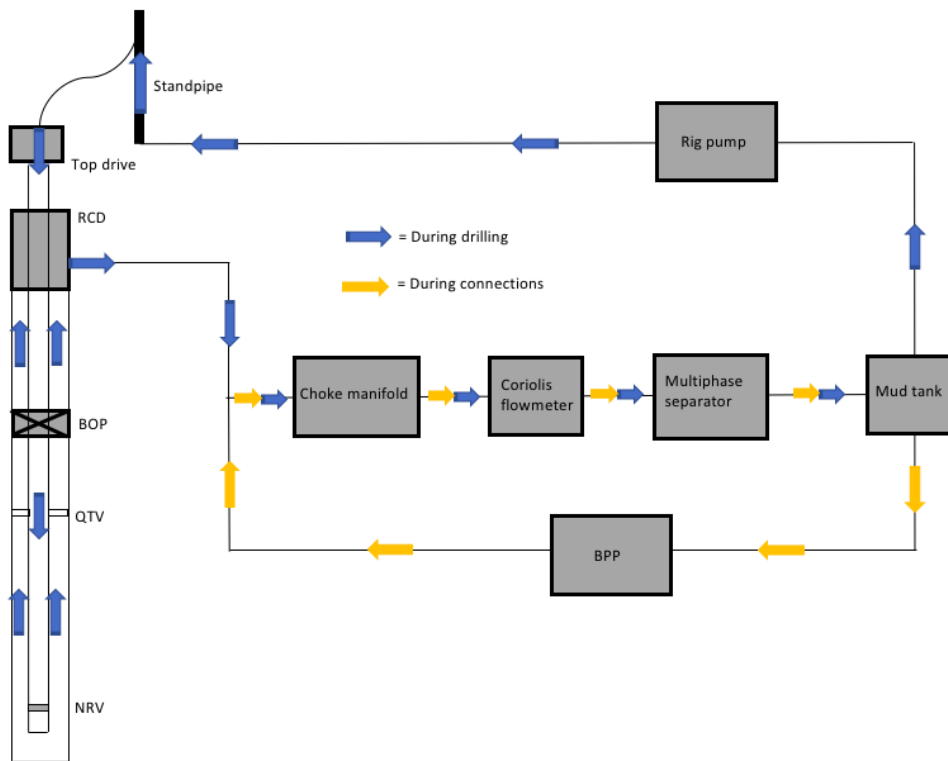

Figure 2.5 Tool Configuration

### 2.5.1 Rotating Control Device (RCD)

The RCD is key to most drilling operations where the pressure needs to be carefully controlled. This includes drilling underbalanced, near-balanced and overbalanced, when there is a known possibility for gas kicks. In MPD operations the RCD is part of the primary well barrier. It is a rotating packer which seals around the drill-pipe while allowing rotational movement. The fluid is diverted through the choke, via the RCD, and is sent to the separators. There are several types of RCDs, and their use depends on the drilling operation. The placement of the RCD differs depending on the type of drilling unit, floating or fixed, pipe dimensions etc. On floating rigs, the placement depends on both the rig design and the water depth. The RCD can be placed subsea, above the BOP, or above or below the tension ring. Placing it below however, allows for better heave compensation. For fixed installations and onshore operations, it is placed directly above the BOP at surface. However, this will be further discussed in chapter 2.8.

As previously mentioned, the RCD was an established tool already in the 1930s. The only difference from the first tools and the ones used today, is that its original purpose was to divert air and gaseous mud and now its primary purpose is to control the pressure. Modern RCDs may have operating pressures up to 5000 psi (345 bar) at static conditions and 2500 psi (172 bar) while rotating. The RCD can be passive or active, depending on the application. [7] The MPD equipment vendors have variations of similar tools, for example Halliburton has the RCD 5000, -2000, -1000 (for land operations) and the Marine Sentry™ 3000 (offshore), while Weatherford has the SeaShield® RCDs. The technology differs, but the main purpose is the same. [16][17]

#### *Passive System*

The passive RCD system is the most used in MPD operations. It consists of a rubber element which seals the annulus. The rubber element is chosen to be smaller than the drillpipe, e.g.  $\frac{1}{2}$ " to  $\frac{7}{8}$ " smaller, in order to create an effective pressure-seal in zero-pressure conditions. Since the rubber element is chosen to fit the drillpipe, one must change the rubber element when changing the drillpipe dimension. The pressure-seal is sealed further when annular pressure is applied. This sealing pressure exerted by the annular



Figure 2. 6 Marine Sentry RCD 3000 [19]

pressure against the rubber element is why it is described as passive. Since the “stripper rubber”, as it is also called, is undersized compared to the drillpipe it must be force-fit onto the pipe. The stripper rubber is installed into the bearing assembly and is locked and sealed. The stripper rubber rotates along with the pipe. Failure associated with the passive RCD, is usually linked to wear on the rubber elements causing leaks in the seal at low pressures. The leak is usually discovered by an observation on the drill-floor, but it may also show up on a pressure test. [7]

### *Active System*

The active system is sealed by hydraulic activation, in addition to the annular pressure. Since it is hydraulically activated, the stripper rubber is pressed against the drillpipe independent of the drillpipe dimension. The hydraulic pressure is adjusted according to the dimension of the drillpipe, tool joints etc. If the stripper rubber is too tight, one can experience excessive wear, problems with stripping the pipe and problems with the WOB (Weight on Bit) The active system is less used offshore due to its larger rig footprint and other technical issues, even though the packer element is more durable than in the passive system. It is not actually called a rotating control device when it is active, it is then called a Rotating Annular Preventer. [7]

### **2.5.2 Choke**

In MPD operations, the chokes are used to control the pressure, rather than the flow, as in conventional drilling systems. It is therefore a part of the drilling system and not the well control system. During such operations, the MPD choke is used continuously and it is therefore necessary with additional well control chokes, although they are not the focus here. There are several different choke types used in MPD operations and they are classified by how they are operated; manual, semi-automatic or automatic, and their closing system; choke gates, sliding plated or shuttles. On the NCS, manual chokes systems are not approved as a part of the primary well barrier, and automated systems are mandatory, according to NORSOK D-010. These automatic systems have advanced control systems. The choke openings are automatically adjusted to meet the pressure requirements in the well and are hydraulically controlled by a PLC (Programmable Logic Controller). This is done by continuously measuring the in- and outflow, pit volume, mud weight and using MWD (Measurement While Drilling) data and real-time control system software to use as input in a dynamic hydraulic flow model and then opening or closing the choke

according to the desired pressure outcome. The flow model is continuously updated as new measurements are provided. The MPD chokes are made to withstand higher flow and more wear, compared to the well control chokes. There are two chokes installed parallel to one another, in order to be able to maintain the pressure and circulation if one of them is e.g. plugged by cuttings. [7] [12]



*Figure 2. 7 Choke Manifold [19]*

### 2.5.3 Drill-Pipe Non-Return Valves (NRV)

All MPD operations require a drillpipe NRV since backpressure is often applied to the annulus. If pressure was to be applied in the annulus without a non-return valve, the drilling fluid and cuttings would be forced back up through the drillpipe, risking plugging, and in the worst case, risking blowing out the pipe. The non-return valve's basic function is to allow flow in the desired direction only, which is why it is also commonly called a one-way valve. NRVs are often placed directly above the bit, and as close together as possible. [12] There are two types of NRVs, the flapper type and the plunger type. The flapper type's advantage is that it allows for wireline operations. [7]



#### 2.5.4 Coriolis Flowmeter

The Coriolis flowmeter is an important component in most MPD systems. It is a mass flowmeter which measures mass flow, volumetric flow, density and temperature, with high accuracy. Other types of flowmeters have difficulties measuring correctly when there are cuttings present in the fluid. The flowmeter has a distinctive U-shape which consists of two parallel tubes. An electromagnetic exciter causes an oscillation of the tubes. When no mass is flowing, the two tubes oscillate symmetrically. When there is flow, the two tubes deform proportionally to the mass flowrate, in a twisting motion. This deformation is registered by two sensors, one at the inlet and one at the outlet. A phase shift occurs between the two sensors and the mass flow rate is derived from this phase difference. The density is computed by the frequency of the oscillations. Denser media have lower oscillating frequencies. The volumetric flow is then calculated by dividing mass flow by density. [13]



Figure 2. 8 Coriolis Flowmeter [20]

#### 2.5.5 Multiphase Separator

MPD does not invite fluid influx, but since drilling is only slightly overbalanced one must have separators at hand to take care of any unintentional influx. There is always a risk of influx when performing managed pressure drilling, as the well is only slightly overbalanced compared to the formation. There are three types of separators; horizontal, spherical and vertical. The latter is most common in offshore operations due to space limitations. [18] The separators used for MPD, are often of the standard type, with regular capabilities, and the process is the same as for conventional drilling. [3] It is common practice to decrease the pump rate in order to stay within the operating range of the separator, when approaching maximum capacity.

#### 2.5.6 Downhole Annular Valves (DHAV) and Casing Isolation Valve (CIV)

Controlling the BHP when pulling out of the well can be problematic during MPD, due to the narrow pressure window. Down-hole annular valves can mitigate this problem. They remove the need for stripping all the way out of the well. Once one has stripped out until right above the valve, the valve is

closed, and one can then proceed to trip out normally. The pressure in the well below the valve will then equalize with the reservoir pressure. The valve must be set as deep as possible in order to decrease pressure build-up, due to eventual gas migration, and decrease stripping distance. There are several different types of DHAV's, Weatherford has the DDV® (Downhole Deployment Valve) and Halliburton has the QTV® (Quick-Trip Valve), which will be focused on here. The difference lies mostly in the required casing size, and the activation type. The QTV® is run as part of the casing, and does not need a larger casing string, but it therefore decreases the ID (Inner Diameter) of the casing. The set-up is purely mechanical, and it is cracked open by applying a slight overpressure above the valve. It is then further opened by pushing the bit through the valve. An engaging sleeve is mounted on the bit, and when passing the valve, it is pulled off, and it locks the valve in an open position. The valve is closed by the same but opposite process. Since the process is mechanical it allows for the valve to be installed at any depth. It also does not need to be retrieved after drilling and completion, which is an advantage. The limiting factor for this type of valve is the reduction of the ID. [7]

### 2.5.7 Backpressure Pump (BPP)

When performing CBHP MPD, with pressure as primary control, the choke cannot be used to apply backpressure unless there is a constant flow across the choke. If the mud flow stops, the choke must be closed completely in order to trap the backpressure in the well. The amount of trapped pressure depends on the control system or the operator's ability to close the choke fast enough. However, an immediate loss of pressure caused by a pump failure or human errors requires action faster than the control system or human operator is capable of. A solution to this problem has been to use a dedicated backpressure pump. The BPP is turned on automatically when the flow from the well is insufficient to apply backpressure by itself, e.g. during connections. [7] It works by pumping fluid into the annulus upstream of the choke manifold. The BPP has several disadvantages, such as a large rig footprint and complexity regarding system control. This complexity can lead to BHP fluctuations during pump start-up and shut-down. [25]

### 2.5.8 Rig Pump Diverter (RPD)

Halliburton's Rig Pump Diverter replaces the role of the traditional backpressure pump and is part of their GeoBalance® MPD Service. In MPD operations, the backpressure pump previously had to provide

adequate fluid supply and flow for keeping the chokes operating during connections. The RPD simplifies the operation by removing the human element during the complex interaction between the rig pump and the backpressure pump.

The RPD is a valve manifold containing a choke which diverts the flow from the rig pumps in order to maintain continuous flow during connections. The flow is diverted to the automatic choke skid via the stand pipe. This allows for precise control of the BHP while performing managed pressure drilling.

With the RPD, the pressure control is improved through the whole pressure range, from low to high pressure connections, by utilizing the rig pumps capacity to keep the chokes within operating range. This reduces the possibility of pressure spikes occurring by reducing connection-time and smoothing the transitions through connections.

The RPD is less complex, which in turn increases reliability. This is due to its simple instalment, smaller rig footprint, ability to fit into a work basket, which eases the transportation offshore, and it requires less power than the backpressure pump. It can be operated manually, step-automated or fully automated. [14]

It has decreased ramp-up and – down time compared to the BPP which has enabled faster MPD connections. In some cases, a 75% decrease in connection time has been seen when comparing the RPD and the conventional backpressure pump. [19]

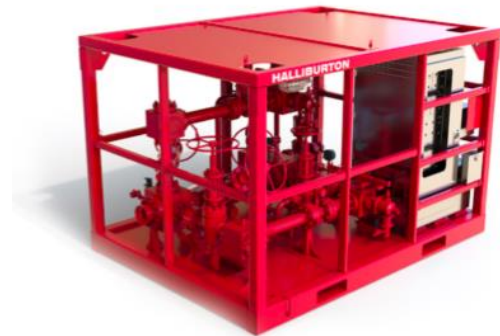

**RPD 800**

*Figure 2. 9 RPD 800 [14]*

The following figure shows how the RPD is set-up in the backpressure system:

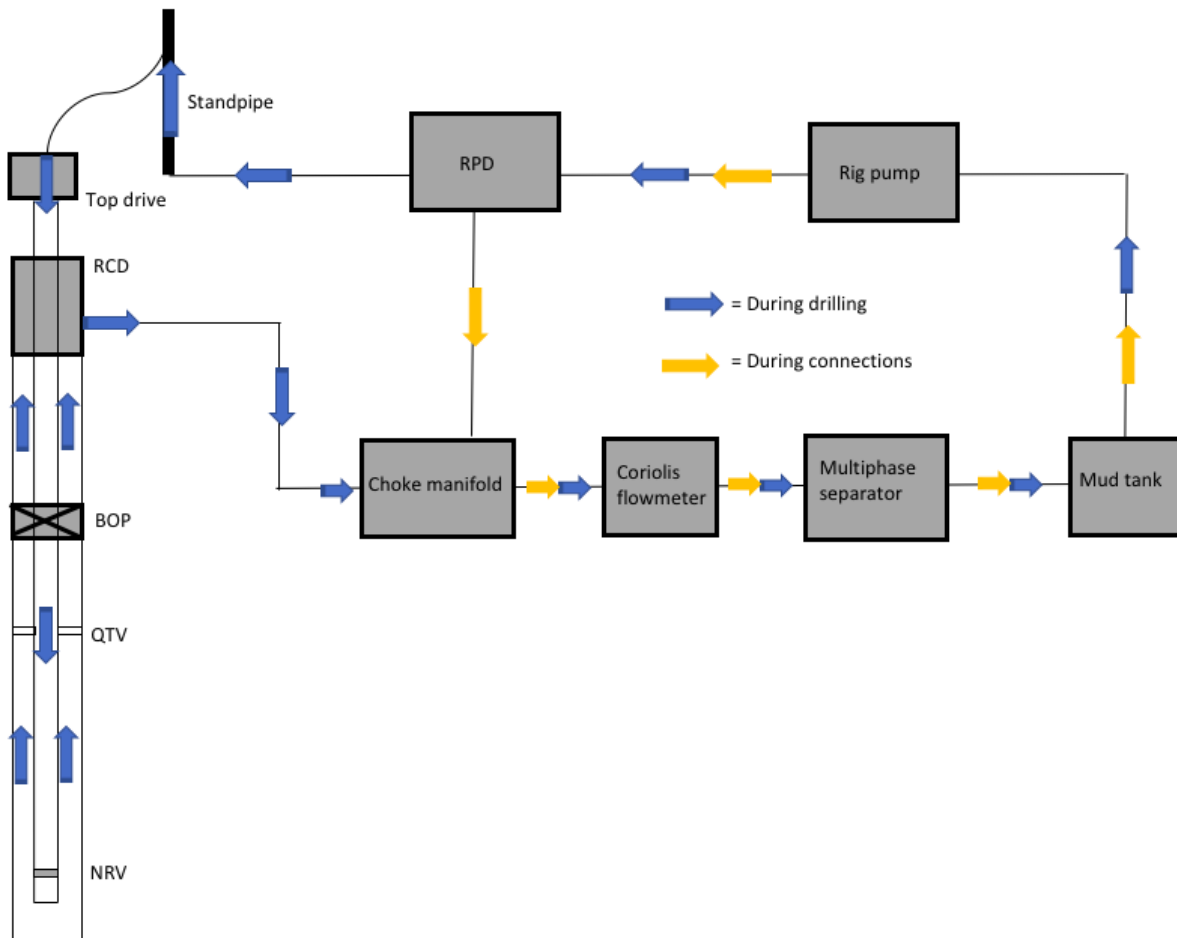

Figure 2. 10 Tool Configuration with RPD

### 2.5.9 GeoBalance® Optimized Pressure Drilling Services

The GeoBalance® Optimized Pressure Drilling Services provided by Halliburton includes both MPD and UBD (Underbalanced Drilling). Based on geomechanical and petrophysical data, the approach is to determine which GeoBalance® option is the most fitting solution for the specific scenario. Once the optimal technique has been selected, advanced hydraulic simulations are performed, and the prospect is economically evaluated. The potential results and benefits are then compared to the cost of the technique, and its limitations. The GeoBalance® package offered is therefore tailor-made to fit the exact reservoir, or drilling operation, in question. Some cases may only require surface pressure control delivered by a simple RCD with a manual choke, but if BHP control is also needed, an automatic choke

system is suggested. For each layer of complexity present in the formation or well operation, the package is expanded to account for the increased need for pressure control. [68]

The Continuous Circulation Method, described in section 2.4, can involve use of the following equipment:

### 2.5.10 Continuous Circulation Valve

Depleted reservoirs on the NCS spurred the development of a CCV (Continuous Circulation Valve). It is designed to withstand full HPHT pressures, including gas filled casings, bull heading and max pressure during standard drilling operations. The valve is a two-position three-way ball valve and enables flow either through the top drive and down the drillstring, or through a side port and down the drillstring. The CCV must be installed on top of each stand of drillstring which is going to be drilled with the CCM. The stands, with the valve on top, are stored in the derrick ready to use. When the length of a stand is drilled down, and a connection is forthcoming, a hose with drilling fluid is connected to the side entry port. The hose supplies fluid flow from the side entry in addition to the flow through the top drive. The ball valve, located inside the cylindrical CCV, is then rotated in order to close off the flow from the top drive and open flow from the side entry. When fluid is flowing through the side inlet, the top drive may be disconnected and a new stand of drillpipe is installed on top of the valve. When the connection has been made, the top drive is connected again, the valve is shifted, and fluid flow through the top drive resumes. Afterwards, when drilling ahead the valve becomes part of the drillstring. [30]

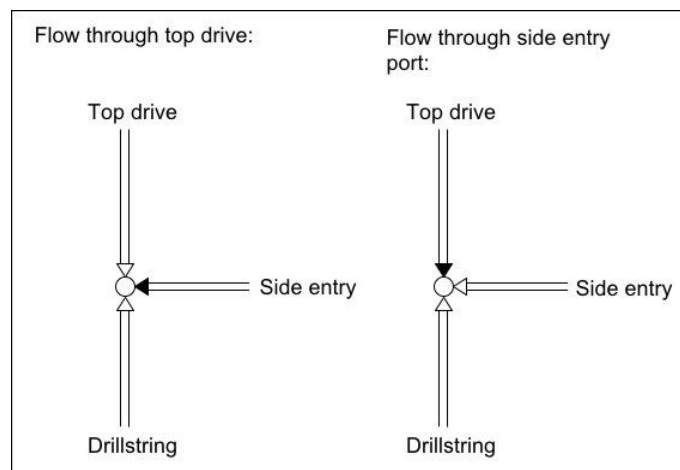
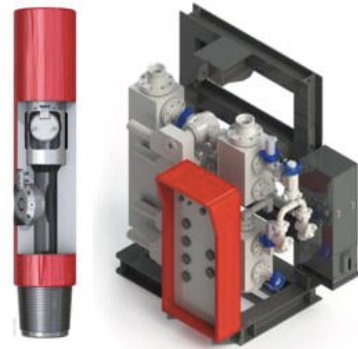

Figure 2. 11 Continuous Circulation Flow Illustration

### *Eni's Circulating Device*

The different vendors have several variations of this valve, but the principle remains the same. Eni's Circulating Device (E-CD™), provided by Halliburton, is one example. The system is comprised of two main items, the E-CD™ Sub and the E-CD™ Manifold. This system utilizes a dual flapper tool, instead of the three-way ball valve. The E-CD™ Manifold diverts flow from the stand pipe manifold to the E-CD™ Sub and is installed close to the stand pipe manifold on the rig floor. The E-CD™ system is often used in combination with backpressure, supplied by an active choke system. This distinctive MPD system is called E-NBD™ (Eni Near Balanced Drilling). [21] [19]



*Figure 2. 12 E-CD™- Circulating Sub [100] and Diversion Manifold [101]*

### **2.5.11 Continuous Circulation System (CCS)**

The CCS was developed by a joint industry project funded by Shell, Statoil, BP, BG, Total, Eni, Coupler Development Ltd. and Varco, supported by the U.K.'s Industry Technology Facilitator and managed by Maris Intl. The development took three years and was used for the first time in July 2003. The CC-coupler is an essential part of the CCS, many times referred to as "the heart of the system". It is located on the rig floor above the rotary table and acts as a pressure chamber around the drillpipe. The system consists of two pipe rams, with one blind ram in between. When performing connections, the pipe rams are closed, and the space between is filled with drilling fluid at circulating pressure. Thus, equalizing the pressure inside and outside the drillstring. The tool-joint pin is then disconnected from the drillpipe and raised clear of the box. The blind ram is closed, dividing the coupler into two sections. Pressure is then bled off in the upper section and the pin connection is removed. In the lower section, circulation through the drillpipe is maintained without interruptions. The new drillpipe stand, which is connected to the top drive, is then run into the upper section of the coupler. The upper pipe ram seals around the pipe, and the upper section is re-pressurized with drilling fluids. The blind ram is then opened, and the connection is performed while starting circulation through top drive and down the new drillpipe. Finally, the pressure in the coupler is bled off, all seals are opened, and drilling resumes. [31]

## 2.6 Barriers

In the previous subchapter, MPD was said to increase the safety aspect of drilling operations. As this is the case in most scenarios, the increased complexity of the drilling system also introduces new risks that must be fully understood and planned for. Performing hazard identifications and consequence analyses are especially important when performing MPD, as the operations are more complex and diverse.

In conventional drilling, the primary well barrier is the hydrostatically overbalanced mud column. The mud weight in the well is high enough in order to exert pressure on the formation, eliminating influx into the well. However, when using MPD, and specifically SBP, an underbalanced mud column is often used in order to drill through narrow pressure windows. This is because when using an underbalanced mud, the pressure in the well is below the pore pressure, but when you apply the backpressure to the system, it is possible to bring the well only slightly overbalance, allowing the pressure in the well to stay almost equal to the pore pressure, with the possibility of easily increasing or decreasing the pressure while you drill by applying backpressure. Well pressure may be corrected faster and easier by changing backpressure, than by changing mud density.

This however, eliminates the possibility of using the mud column as the primary well barrier. If so, the MPD pressure control equipment becomes the primary well barrier. The secondary well barriers are the same for conventional- and MPD. They have the criteria of independency from the primary well barrier and should be designed to be able to contain and circulate an eventual kick. Increasing SBP however, causes additional stress on the equipment and the MPD design definition limits the pressure that can be applied to the annulus to be 80% of the weakest elements pressure limit. [38] The secondary well barrier consists of an envelope of several different well barrier elements, such as casings, liners, cement, wellheads and BOPs. In MPD, a well barrier element is *“an object that alone cannot prevent flow from one side to the other side of itself”*. [39]

The well barrier acceptance criteria for MPD is explained in NORSOK D-010, subchapter 13.3.3, and written for MPD/UBD operations using a surface BOP. It includes information about RCD placement, choke regulations, surface equipment criteria, BHP limits, kick tolerance etc. The following is an example of a wellbore schematic for drilling and tripping of string with an underbalanced fluid. [12]

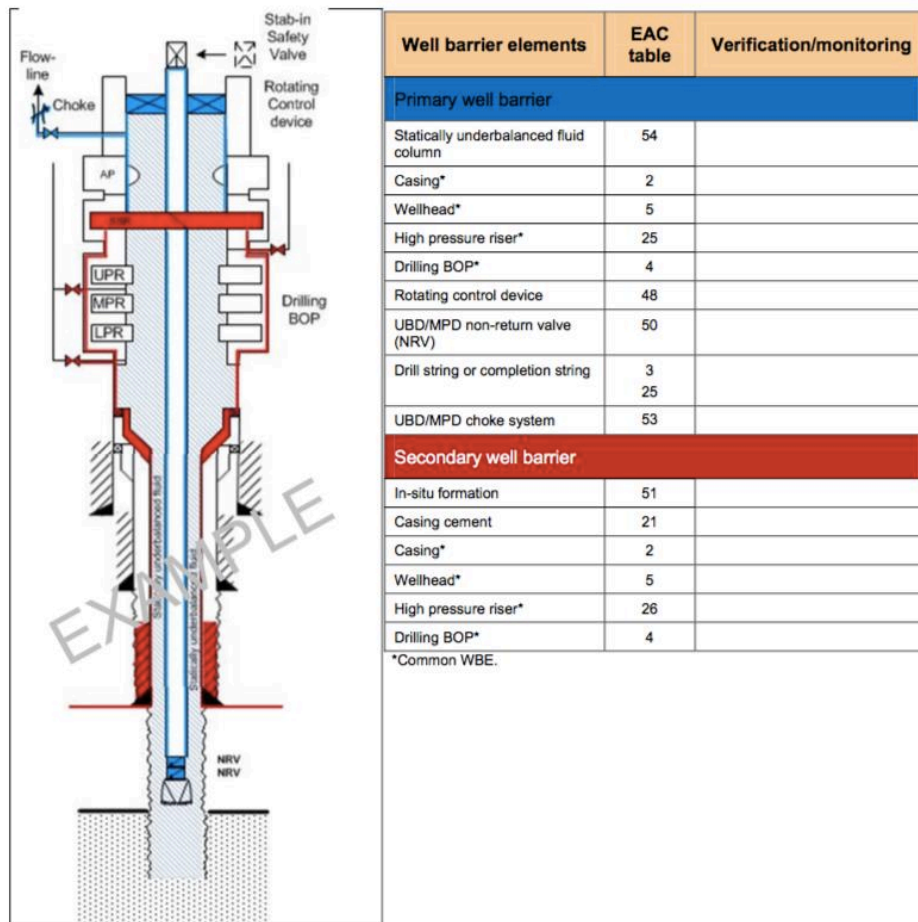

Figure 2.13 Well Barrier Schematic with Underbalanced Fluid [12]

## 2.7 Well Control

When using MPD, kick incidents can be detected at a much earlier stage and a much lower volume. This is due to the increased instrumentation (downhole pressure sensors, Coriolis flowmeter etc.) compared to the traditional detection via evaluation of pit gain. The traditional well control procedures require the well to be shut in to avoid further influx. The rig pumps are shut off and the well is checked for flow. Turning the rig pumps off, however, eliminates the frictional pressure in the annulus which decreases the BHP and invites further influx. [37] The influx itself is then allowed to flow into the wellbore until the pressure is stabilized. When the pressure in the well is stabilized, the formation pressure can be read off, and the required mud weight needed to regain overbalance can be calculated. There are several kill methods available, with differences regarding the circulation process, but the pressure in the well cannot



be increased to exceed the pore pressure and prevent further influx until the pressure has been determined by well stabilization and the kill mud is in place. This process is slow and increases the risk of further complications, e.g. stuck pipe. [40]

In SPB MPD the reduction in BHP is avoided by keeping the rig pumps on and applying backpressure instead. [37] The influx size is therefore minimal compared to using conventional procedures and the influx may be removed in hours instead of days. [40] Small influxes can, as mentioned, be circulated out via the MPD equipment without having to close the BOP. The system can be controlled by having a requirement that the inflow must equal the outflow, or by having a set-point pressure downhole which automatically regulates the choke to meet the desired pressure conditions. There are limitations for how large kick volumes the MPD system can handle. The RCD and the MGS are the usual weak links regarding pressure and flow limits and will be further discussed later in this subchapter. The kick will expand when travelling up the well, and the choke-pressure must be increased to compensate for the decline in hydrostatic pressure. The enhanced kick detection with SBP MPD enables the possibility of performing DPPT's (Dynamic Pore Pressure Test) to find the pore pressure of the open hole in a safe and controlled manner. The true pore pressure however, can only be found if the mud in the wellbore is underbalanced. The DPPT is performed with fluid flowing through the drillstring while rotating, which makes the situation very similar to drilling conditions. The test is performed by decreasing the SBP until an influx is detected, the pressure is then read off, and the SBP is brought back to the initial value and the influx is circulated out with the MPD equipment. [38][67] Performing this test and finding the true pore pressure greatly improves the ability to drill only slightly overbalanced in very narrow pressure windows.

Applying MPD well control procedures offshore provides a great improvement in kick detection as the closed system and placement of the RCD below the slip joint removes the effects of rig heave from influx volume measurements. However, in many cases, the application of MPD is only implemented as part of the drilling process, and conventional well procedures are still used without considering the impact of using them in combination with each other. Therefore, the application of MPD on rigs is not automatically beneficial. For example, MPD equipment is able to detect very low influx volumes that otherwise would have gone undetected without any issues. If the process is set-up such that upon influx detection the control is handed over to the conventional well control procedures, the NPT would increase drastically due to unnecessary shut-ins, and with NPT comes the increased risk of other related problems, such as stuck pipe. This enhanced detection can also lead to ballooning and thermal effects being wrongly interpreted as influxes. Another issue with handing the well control procedures over to

the rig upon influx detection, is the reduction in annular friction pressure due to pump shut down. The practice should then be to use the choke for maintaining CBHP and prevention of further influx. It is very important to have a clear picture of how the MPD system will work together with the rig's well control system, and the basis of well control must be shifted from thinking that total shut-down and handover to the secondary well barriers is the only way to proceed after influx detection. [40] The Influx Management Envelope is one such method that guides the process of deciding whether conventional well control must be applied, or if using the MPD equipment is sufficient.

### 2.7.1 IME (Influx Management Envelope)

In 2016, Culen et al. [85] introduced the IME (Influx Management Envelope) Concept which offers more detail than the traditional well control matrix. The IME is used to rapidly analyze influx events in order to take the correct action when influxes occur in MPD operations. It is based on kick tolerance concepts and is a graph which shows the relationship between the influx size and the surface pressure to be expected while circulating the kick (post influx). The graph, Figure 2.13, is divided into three or four color-coded regions for making the decision-making process easier. It depicts if there is an influx present, and if so, it calculates whether it can be circulated to surface within the primary wellbore barrier or if the secondary wellbore barriers should be activated (BOP closed). The green region stands for normal MPD operation and no influx detected, yellow stands for detected influx, but possible

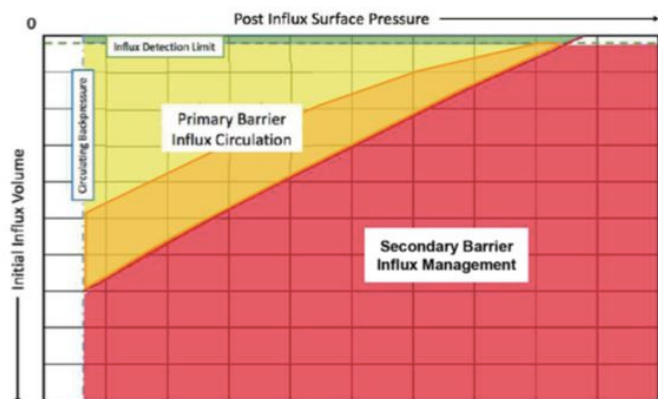

Figure 2. 14 Influx Management Envelope [57]

equipment), orange stands for influx detected and can be circulated out within primary barrier if one or more parameters are adjusted (e.g. mud flow rate reduced to not exceed MGS limits) and the red region stands for influx detected and secondary wellbore barrier must be activated (BOP closed). [57]

The pressure limits and the surface flow limits for the system are used for calculating the limits for the IME between the different regions. It is very common that the pressure rating of the RCD is the weak link on surface. The following values are extracted from SPE 185289 and the case they investigated. The dynamic/stripping pressure rating of the RCD in this case [57] was 1500 psi, and a 20% safety margin is widely used resulting in a surface pressure limit of 1200 psi. However, it is also common that the most

restrictive pressure is the loss initiation pressure in the subsurface. The flow limits are typically restricted by the MGS flow capacity. In this case, with a 20% safety factor included, the MGS flow capacity was at 5.28 MMSCFD. [57]

In order to implement the IME safely, the designer and the operators must fully understand the concept; how it works and how to use it and take appropriate considerations. Specific IME's should for instance be planned for each section of the well, while also adjusting it continuously when changes arise in the system or new information is available (mud weight, SBP, drilling rates, FIT/LOT). It is also important that the IME should only be used upon influx detection, and then the recommended action from the color-coded region should be followed through. It should not be referenced further during the circulation process. This because the influx will expand while travelling up the well, which may cause the control parameters (influx volume, SBP) to be increased and cross the red limit, which in turn would lead to unnecessary shut-ins. [57]

In this article [57], an arbitrary maximum influx value of 20 bbl was chosen as the limit before the second barrier must be activated. This because the system should detect influxes at less than 2 bbl and be able to control them in less 10 bbls , which could suggest that if the influx is not handled before reaching 20 bbl there may be a fault in the equipment or incompetent personnel involved. In [57], a transient flow model was used to develop the IME charts. The chosen maximum value before the conventional well control procedures are initiated depends on the specific well, a HPHT well on the Mandarin EAST Field on the NCS for example had 1 bbl as the maximum value. [33]

### 2.7.2 NORSOK Standard

The NORSOK D-010 standard states under 13.5, "Well control action procedures and drills", that the main operational risks are to be identified and contingency procedures made, with regards to the specific equipment and well data. Subchapter 13.6 "Well control matrix" states that a well specific well control matrix shall be prepared based on the equipment and design limitations which are present for the operation. The matrix shall include criteria for when to stop the operation, the definition of a well control incident and first action procedures. [12]

### 2.7.3 Oil Based Mud vs. Water Based Mud

Kick detection and handling is also mud-type sensitive. In SPE 191345 [56], the authors simulated a kick in a HPHT SBP MPD scenario. The goal of the simulation was to compare and highlight the differences arising from the choice of mud-type. The simulated kick entered the well at 4 kg/s during 120 s and was circulated with a rate of 1500 lpm. The BHP was chosen to be 700 bar, the mud density 1.7 s.g. and the kick size 2 m<sup>3</sup>. The chosen flow conditions, fluid properties and other inputs affected the results of the simulation and it is important to keep this in mind when analyzing the results.

The simulations showed that a kick in WBM will reach surface faster than a kick in OBM. This due to the kick not dissolving in the mud, and the gas will therefore travel up the well faster since it has much lower density. The kick will dissolve in the mud in the OBM case and will therefore travel up the well at the pump velocity.

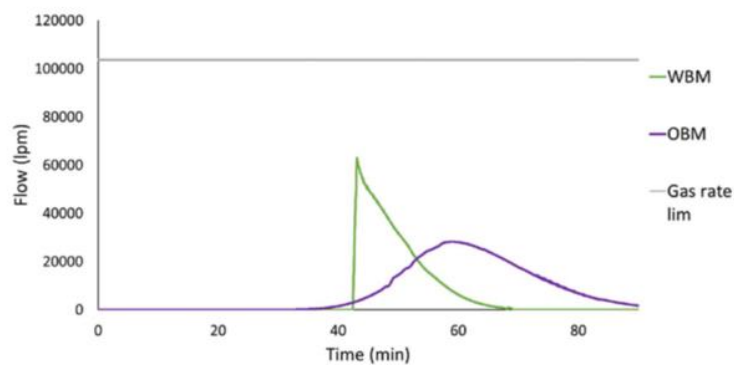

Figure 2. 15 Gas Rate Out vs. Time for WBM and OBM [56]

When using WBM a higher backpressure must be applied to compensate for a less effective hydrostatic column. The hydrostatic column of fluid is less effective in WBM than in OBM, due to the larger amount of free gas present in the well. Using OBM is therefore beneficial since it lessens the load on the equipment. As mentioned before, the weak link in the backpressure system is often the RCD, and the chance of reaching its limit is reduced.

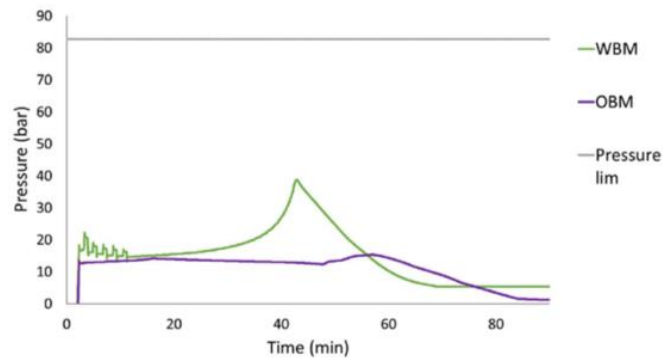

Figure 2. 16 Choke Pressure vs. Time for WBM and OBM [56]

The simulation also showed that the pit gain when the kick reached surface was a lot less for the OBM case, which is an indication of less gas boiling out of the mud.

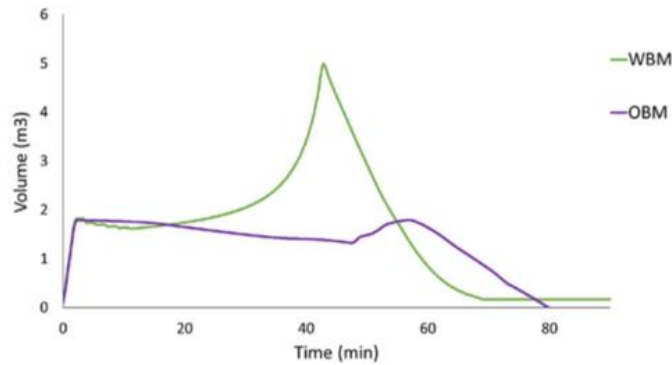

Figure 2. 17 Pit Gain vs. Time for WBM and OBM [56]

The mud rate out of the well was therefore lower for the OBM case. Hence, the chosen mud system will also have a large impact on how influxes affect the pressure and flow conditions in an MPD system and transient flow models can be used for obtaining more insight. [56]

## 2.8 CBHP Applied from Floaters

CBHP MPD from floaters is a relatively new technological development. The placement of the RCD is the main difference between the various options for enabling such drilling. The RCD can either be installed at surface together with a surface BOP, above the slip joint (collapsed and locked or with the inner barrel removed), below the tension ring and slip joint or at the subsea stack below the lower marine riser package. [58] The optimum placement of the RCD depends on the MPD type, the heave, current and

weather conditions and the associated pressure ratings. [59] [60] There are advantages and disadvantages associated with each variation, however there is one solution that has the best track record and is considered the most viable option for the CBHP variation of MPD, especially in rough waters, and that is the RCD installed below the marine riser tension ring. [61]

As briefly mentioned in subchapter 2.7 (Well Control), using floaters for CBHP MPD can be very beneficial with regards to influx volume measurements and thereby kick detection resolution. When the water is rough and there is significant rig heave, the volume of fluids going through the slip joint can vary a lot. By placing the RCD below the slip joint, this volume is eliminated from the flow loop and more precise volume measurements can be made. [62] Placing the RCD below the riser tension ring and slip joint also enables higher SBP application compared to installing it above, which increases drilling flexibility.[63] The system is only limited by the marine riser and RCD's pressure rating.[64] This placement eliminates the need of modifying the rig's existing upper marine riser system and allows significant drillship rotation in accordance with the prevailing wind, current and wave directions, as the MPD hoses are kept clear of the tension lines. [64] [61] Rapid shift from conventional drilling to MPD drilling is another benefit with this design.[61]

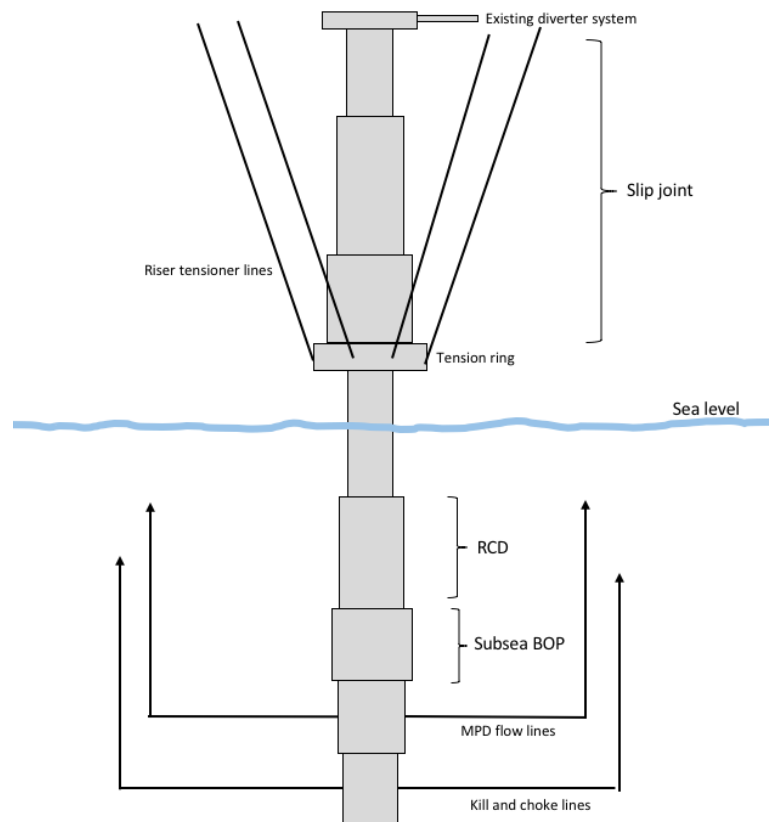

Figure 2. 18 BTR RCD, Inspired by [64]

Before this technological advancement, many operations were performed with the RCD installed in the other possible locations. The first application of an RCD from a floating structure, as mentioned in 2.1, was performed by Weatherford in 2004, with a concept called RiserCap™.[86] However, this technique had several limitations. The system required the slip joint to be collapsed and locked due to pressure ratings, which compromised the heave compensation of the floater. The set-up also did not have an

upper flange, which prevented the ability of the returns to go to the rig diverter. Weatherford introduced the SeaShield® RCDs in 2008, as a remedy for the RiserCap™'s limitations. This RCD made it possible to connect at the top and bottom and was called a DS (Docking Station). This set-up allowed the returns to flow to the rig diverter at all times and enabled easy transition between conventional- and MPD mode, but it still had several limitations. After this, a subsurface RCD was developed and was installed below the tension ring. This made it possible to use the telescopic joint, and heave motion could be compensated. However, the flowlines etc. prevented the floater from being able to change heading. Finally, they landed on the BTR RCD which was aforementioned and is considered “state of the art”. [8686]

## 2.9 Case Studies

### 2.9.1 Continuous Circulation Method: E-CD™

The CBHP technique was successfully applied to the Temsah Field in the Mediterranean Sea. In this case the CCM (Continuous Circulation Method) was used. In this area Eni's E-CD™ system has been the preferred method to achieve CBHP and was used to drill the TEMSAH 4-13 well in 2009. The main objective of applying the E-CD™ system was to decrease the number of casings and thereby the operations time and -cost. The Temsah 4-11 well was drilled conventionally in the same area and was used as a comparison to highlight the benefits of using the E-CD™ system. The 4-13 (MPD) well was mainly drilled through layers of shale and sandstone, with some depletion present in the formations. When drilling the 4-11 well (conventional), losses were experienced during cementing and while running casing and liner. The comparison showed that with the conventional method two casings (11 ¾" liner and a 9 5/8" casing) were required to get from 2909 m MD (Measured Depth) to 4209 m MD. With the E-CD™ system applied on the 4-13 well, only one casing was required to get from 2894 m MD to 3827m MD and no losses were experienced during the operation. This was possible due to the CBHP method which overcame the depletion problem in the formation. The CBHP method removed the need for the 11 ¾" liner and its cement job, which cost 446,075.00 USD on the conventionally drilled well. The conventional well also experienced losses, totaling to 248 m<sup>3</sup>. The E-CD™ system used on the 4-13 well saved 13 days of operation and 1,226,866 USD compared to the 4-11 well. [21]

### 2.9.2 Surface Backpressure + Continuous Circulation Method: ENBD™

The E-NBD™ method (E-CD™ + MFC) was used to drill exploratory HPHT wells in the Lower Mediterranean Sea. Here the CCM was combined with surface backpressure system. This method made it possible to reach these targets for the first time. The wells in this area are prone to kick-loss situations and the HPHT environment makes drilling these wells challenging. Eni used a step-wise approach to face these challenging wells. Firstly, an RCD was installed to reduce the risk of gas on the rig. Continuous circulation was also implemented, but the uncertainty in pore pressure estimation created drilling challenges, and lead to unnecessary casings and abandonment before reaching TD. It was when these attempts failed, they decided to use the MFC method and the CCM in combination, called ENBD™. The MFC method's ability to accurately understand the downhole conditions and provide a quick response to any changes together with the CCM's ability to avoid temperature and pressure fluctuations during connections proved to be the solution that was needed.

The well in focus here was the first well where Eni applied the MFC method. In the beginning, the well was drilled with the E-CD™ valves only and after some time the MFC was installed (E-NBD™) which made this well very suitable for comparing the two methods. They chose to keep the MFC offline in the beginning due to surface backpressure concerns. They experienced several kicks while drilling with the E-CD™ which were handled conventionally, and it was when they experienced the kicks in the 8 ½" section they finally decided to use the MFC. They experienced a significant improvement with respect to drilling time, NPT and kick/loss events.

To compare, when drilling the beginning of the 8 ½" section with only the E-CD™ valves, they spent 17 days drilling 29 m. During this time, 2 kicks were detected which caused 13 days of NPT. After implementing the ENBD™, they were able to drill 408 m and reached TD in the same time frame (17 days), even when five of these days were spent on a tripping operation to fix LWD (Logging While Drilling) issues. During this interval, no kicks or losses were detected. A 2.4 m<sup>3</sup> pit reduction was observed, but the MFC did not show any losses downhole and drilling therefore proceeded since no cause was identified. The conventional well control most likely wrongly interpreted gas expansion close to surface, connection gas or ballooning as kicks, but the MFC method accurately interprets such events, and therefore enables drilling to reach TD.

Reaching TD made it possible to drill the 5 7/8" section and evaluate the formation for the first time. The ENBD™ proved its reliability and capability in this section as well. To sum up, 39 m<sup>3</sup> were taken during



kick events with the MFC offline, compared to 3.8 m<sup>3</sup> when it was online. It took 1, 3 and 11 days of NPT before drilling could resume after kick incidents with the MFC offline and it took 1 day when it was online. [35]

### 2.9.3 Surface Backpressure

MPD was used to drill an exploration well on the HPHT Mandarin East field. [33] HPHT fields often suffer from wellbore breathing, which is a phenomenon that happens due to the pressure difference when turning the rig pumps on and off. When the pumps are on, the ECD is larger than the fracture pressure which induces small fractures in the formation, which are filled with mud. When the pumps are turned off, the ECD decreases and the fractures close up forcing the mud back into the wellbore. When the mud flows back into the wellbore, it is sometimes accompanied by formation water and gas which can cause a need for extra circulation time. [36] This well was especially prone to wellbore breathing, which made pore pressure evaluation and kick detection critical. Although, by keeping the BHP constant the need for extra circulation time was eliminated. SBP was decided to be the preferred MPD method, but in this case an overbalanced mud weight was selected since the extreme HPHT environment demanded cautiousness. Using an overbalanced mud decreases risks accompanied by influxes and acts as an extra safety in cases with abnormally high temperature and pressure. Surface backpressure was therefore only applied if an influx was detected and was not required to be applied constantly to keep the well at balance. Modifications to the rig were needed to implement MPD, but the amount of time and money that went into training, risk assessments, modifications, etc., were an important factor in the success of the MPD techniques. The MPD setup consisted of closed circulation system by use of an RCD, Coriolis flowmeter for accurate flow detection, automatic chokes and early kick detection algorithms. The application of SBP saved time and money, increased safety and minimized the effects of wellbore breathing. It was estimated that using the MPD system saved them 10 days, and 7.5 MM\$. The well was drilled with a very narrow pressure window of 0.04 s.g. Using MPD increased the safety of the operation and enabled drilling to TD which gave significant value to the formation evaluation program. [33]

### 2.9.4 Surface Backpressure

Halliburton successfully drilled the A-10B well on the Gullfaks field using a SBP MPD system with an advanced transient hydraulic model. SBP MPD was primarily chosen as a risk mitigating factor. Part of

the field is overpressurized due to water injection which has removed the drilling window in many areas. The first goal of this well was therefore to drill through the overpressurized area and confirm drillability.

Initially, the plan was to drill only one section with the SBP MPD system, however, due to its success in detecting losses and BHP flexibility it was ultimately used to drill three sections and run and cement two liners. Several losses were detected while drilling, however they were quickly detected and reduced with the SBP MPD system. The SBP MPD system also allowed for determination of the unknown drilling window. The SBP MPD system was fully automatic due to the hydraulic model, and consisted of a choke skid, control cabin, flow meter and a BPP. For this case a pressure variation of  $\pm 5$  bar was allowed, and made possible, by the SBP MPD system together with the hydraulic model. The hydraulic model calculated the choke pressure from the control cabin. The A-10B well was the first MPD well to be drilled from the Gullfaks A platform, and the first MPD cementing operation to be performed on the Gullfaks field. Using SBP MPD on this well allowed the well to be drilled and completed 54.3 days ahead of plan. [87]

#### 2.9.5 Surface Backpressure + Continuous Circulation Method

The Kvitebjørn field is a severely depleted, gas condensate HPHT field. The pressure depletion is caused by early production during development drilling. The field suffers from 0 to 170 bar depletion, which has created a convergence between the pore- and fracture pressure, making it impossible to reach TD using conventional drilling without suffering massive losses. [32] By utilizing the CBHP method on the remaining wells, the undrillable wells have become drillable. The system was able to keep the BHP within a  $\pm 2.5$  bar window. The CCM and SBP methods were successfully used in combination with each other and significantly improved the safety aspect of drilling. Using the MPD equipment for well control allowed influxes to be detected at a much earlier time and they were kept at a smaller volume compared to conventional drilling. The kick could be routed through the MGS without decreasing BHP which increased safety for personnel on the rigs. [34] NPT due to well control incidents decreased, and in turn saved rig time.

## 2.10 Challenges and Benefits

CBHP has many benefits and a wide range of applications, some of which were briefly mentioned in the introduction to this chapter. The wells that benefit most from CPHP techniques are wells in mature-, HPHT- and depleted fields with narrow pressure windows, wildcats with unknown formation pressures and coal formations. There are pros and cons associated with the CBHP method, and how the different techniques are used. If only CCM is used, the pressure fluctuations due to pumps on/off are avoided which is very beneficial in sensitive formations where the mud loss/gain boundary is very narrow. Unfortunately, the flexibility of the mud weight is reduced and CCM alone also does not allow for the BHP to be controlled as closely as with SBP and small kicks cannot be circulated out of the system via the MPD equipment.

### 2.10.1 Handling Tight Drilling Margins and Unknown Formation Pressures

Depleted- and HPHT fields often suffer from very tight drilling margins. HPHT fields which are in addition suffering from depletion have even more limited drilling windows. (32) Drilling in these fields is difficult or even impossible with conventional drilling. Wells in such areas are often abandoned due to high costs and inability to reach TD. They are especially sensitive with regards to BHP variations, which temperature changes, drillpipe rotation and swab/surge contribute to, significantly. Using the E-CD™ and MFC (E-NBD™) on such wells has proven to mitigate these temperature and pressure fluctuations while providing a clear picture of the BHP and has made it possible to stay within the tight drilling window. [35]

Exploration wells can be challenging to drill due to the uncertainties in the formation pressures and geology. The need to drill and explore challenging environments is becoming more and more common, as most of the “easy” reserves have already been found and produced. Many of the present fields, in previously “easy” environments have reached maturity and are suffering from depletion which is making further drilling difficult. Drilling in these environments however, has been enabled with the closed-loop MDP system. The use of MPD, especially E-NBD™ has enabled drilling to TD which was not possible using the conventional method. This has allowed the wells to meet their commercial and technical objectives by collecting valuable information about the possible hydrocarbon reserves. The pore- and fracture pressure can easily and accurately be determined while allowing the mud weight to be properly adjusted. This has several benefits, such as avoiding loss of circulation, stuck pipe and low ROP (Rate of

Penetration). The simplicity of the E-CD™ valve and the MFC is highly beneficial as there is not much additional equipment needed and can be deployed both on- and offshore, on floating or fixed rigs. [35]

### 2.10.2 Handling ECD Issues & Wellbore Stability

Wellbore breathing is a phenomenon that happens due to the pressure difference when turning the rig pumps on and off. When the pumps are on, the ECD is larger than the fracture pressure which induces small fractures in the formation. These fractures are filled with mud, and when the mud pumps are turned off, the fractures close up and the mud is then forced back into the wellbore. When the mud flows back into the wellbore it is often accompanied by formation water and -gas which can cause a need for extra circulation time. [36] This is a common problem in HPHT wells, exemplified in the HPHT Mandarin East Field case study. In such fields, pore- and fracture pressure evaluation and kick detection are critical. The CBHP mitigates this issue by eliminating the change in ECD during pumps on/off, either by applying SBP or by providing continuous circulation. The need for extra circulation time due to wellbore breathing is therefore eliminated. [33]

In highly deviated wells and ERD (Extended Reach Drilling) the effect of the ECD can be prominent and cuttings cleaning is a common issue. If the well in addition has high temperature, the temperature change in the bottom of the well can be large during connections. The more effects that are present, i.e. the longer the well, the more horizontal the well, the more benefit continuous circulation has to these situations. Continuous circulation prevents cuttings from settling in the low side of the well and accumulating during pumps off, reducing the risk for e.g. stuck pipe. ERD wells are defined as having a “step-out of more than two-to-one”, meaning that for every foot drilled vertically, deviation in the horizontal direction is at least two feet. [37] The main risk when drilling extended reach wells, is exceeding the fracture pressure. This because the fracture pressure gradient remains relatively constant in the horizontal direction while the ECD increases with MD. SBP mitigates this problem by enabling the use of a lower density fluid and thereby keeping CBHP. [37] Another issue with extended reach wells is that oil- or synthetic based mud is often preferred for its high lubrication effect, but these muds are highly compressible and may cause delays in pressure propagation when performing MPD operations. [37]

Drilling in sensitive formations, e.g. through coal layers, may be improved by MPD. These formations are prone to wellbore collapse if the BHP is not maintained above the borehole stability limit. They are also

sensitive to cyclical changes in the wellbore pressure, which may worsen the unstable zones. Keeping the BHP constant when drilling through such formations is therefore beneficial in trying to keep the borehole intact. [8888]

### 2.10.3 Improved Well Control

As explained in the Well Control chapter (2.7), the closed loop drilling system provided by the RCD and the Coriolis Flowmeter both significantly increase safety in such operations. The SBP MPD equipment enables very quick influx detection and keeps the influx to a minimum by applying SBP and the influx (depending on the size) can then be circulated out via the MGS without reducing the BHP by stopping the mud pumps. Losses to the formation are also easier to detect due to the high accuracy of the in- and outflow measurements performed by the Coriolis flowmeter, and SBP is then reduced accordingly to prevent further losses. [4]

### 2.10.4 Saving Casing Strings

The CBHP method also allows for the use of fewer casing strings. This because the BHP is kept constant, avoiding pressure fluctuations due to pumps on/off which enables drilling for longer periods of time before reaching the pore- and fracture pressure limits. Both SBP and continuous circulation contribute to this effect. The Temsah field case described in case studies exemplifies just this with the E-CD™ system and shows how it contributed to decreasing the number of casing strings required to reach TD. [21]

### 2.10.5 Reduced NPT

Many of the above benefits, such as improved kick detection and -handling, reduced circulation time due to wellbore breathing, reduced number of casings and improved cuttings cleaning result in a final benefit of reduced NPT. As the NPT on the wells go down, so does the cost of the well.

### 2.10.6 Challenges

Although it can seem like the CBHP is only beneficial, some challenges do exist. For instance, enhanced kick detection may initiate well control procedures prematurely on influxes that would have gone

unnoticed during conventional drilling and could have been circulated out with no problems. [40] There is an increased amount of equipment needed to make up the MPD system. This may be a challenge on offshore rigs as they may suffer from space limitations and integration with the existing equipment may be difficult. Though, the application of CBHP decreases costs in most wells, if applied to wells that don't necessarily require MPD, the cost of implementation may exceed the savings.

## Chapter 3 – Controlled Mud Level (CML)

The CML technology is a Dual Gradient Drilling (DGD) method. Although there are many different DGD methods that can be used for drilling depleted reservoirs and deepwater wells, the focus in this chapter is going to be on CML and mostly Enhanced Drilling's technology; EC-Drill™. The reason for this is that EC-Drill™ has been used on the NCS.

Comparing the EC-Drill™ method with the conventional backpressure MPD method, one can better understand the effect of the method. The backpressure method "extends" the fluid column by applying backpressure, which leads to a steep mud pressure gradient. The EC-Drill™ method, however, reduces the actual height of the mud column, which causes a flatter mud pressure gradient. This allows for a significantly lower pressure applied on the weak casing shoe, yet one is able to maintain the pressure required to prevent influx deeper in the drilled interval.

EC-Drill™ is a CML technology that was developed in order to provide economic and improved benefits during all subsea well operations. The method can be applied in all operations during the life of the field after the riser is run, this includes drilling, completion, well interventions and work overs. The design and development of this technology is well suited for the harsh and challenging metocean (meteorology and (physical) oceanography) and environmental conditions, which is experienced on the NCS. This deepwater MPD method has no need for major modifications of the components of the riser system. This means that the weather capability of the rig is not changed, which often can be a problem when using the RCD system. [44] [45] [46]

### 3.1 Dual Gradient Drilling (DGD)

An increasing number of subsea fields on the NCS are entering maturity. The NCS is the largest, most mature subsea area in the world. Although the structure of the formations will stay the same over time, the formation pressure will change over time due to production. This pressure depletion causes a reduction in the drilling window; in fact, the drilling window can close entirely and make depleted fields undrillable with conventional procedures and technology. As mentioned earlier, MPD is considered as a solution for narrow operating windows. However, the original backpressure MPD method was developed from land drilling and with a closed loop system and is not yet applicable for floaters on the NCS. The reasons for this are mostly related to well integrity and safety, rules, regulations and operational environment. [45] Technologically, it is possible and it is used in other places in the world. Other

methods are needed to cater for floaters and their special operating conditions. Deepwater wells also need different methods. This is because of the pressure difference between the annular hydrostatic pressure and the formation pressure, which is typically defined by the column of seawater above. This pressure differential may cause problems with overbalance when using conventional riser return drilling methods. Another problem that can occur with conventional methods is that it can be difficult to reach TD because of too many casings as mentioned in chapter 1.3.4. DGD is an MPD method developed to help fix these issues caused by deepwater wells and depleted reservoirs. [41]

The idea of DGD was introduced in the 60's. When utilizing DGD, a fluid with lower weight than the mud (e.g. mud with lower weight, seawater or gas/air) is introduced to obtain a lower bottomhole pressure. There are several methods to achieve this dual gradient condition, and they all trick the formation to think that the rig is closer to the seabed than it actually is. [41]

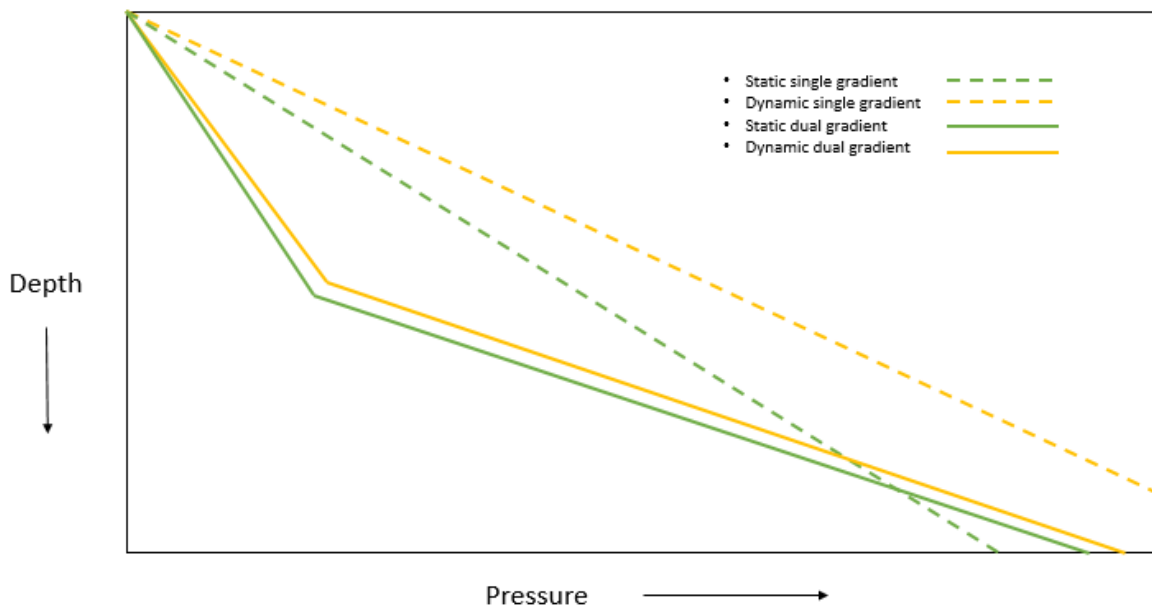

Figure 3. 1 Static and Dynamic Conditions for Dual and Dingle Gradient Drilling, Inspired by [74]



### 3.1.1 Historic Development

The development of the DGD system started in the early 1960s. The goal was then to eliminate the riser and it was originally labeled Riserless Drilling. The technology which existed at that time was not sufficient to do so and the need was not that big as the conventional riser-based technology was capable for the considered water depths. The need for DGD became more urgent after several deepwater discoveries in the Gulf of Mexico. The interest of lease sales of the deepwater blocks increased and the competition for drilling rigs with the capability for deepwater drilling was intense. Operators and contractors were motivated to find ways to extend the capabilities of drilling rigs for shallow waters because the deepwater rigs were in short supply. The concept of DGD reduced the weight of the riser and the volume of mud, which allowed smaller rigs to be used for deepwater wells. Ultimately, the need to manage narrow drilling operational windows in deepwater became the driver to developing DGD. [71]

Early in 1996, a number of deepwater contractors, service companies, operators and one manufacturer gathered together to discuss some potential approaches to riserless drilling, which today is known as dual gradient drilling. Conoco and Hydril were the ones that started investigating the concept of riserless drilling and, as they realized that this was a task too big for only two companies to take on, they organized a oneday workshop, hosted by Hydril. The purpose was to confirm and show that DGD could be the solution for the needs of deepwater operations; they wanted to show that it was in everyone's best interest to support the development of this technology. Approximately 25 operators, contractors and service companies attended. This initial meeting turned out to become one of the largest and most significant JIP (Joint Industry Projects) in the history of this industry. This project started as the "Riserless Drilling JIP" and continued as three overlapping phases, it is now called the SMD (Subsea Mudlift Drilling) JIP. The main goal was to provide a total solution for dual gradient drilling. This solution had to include the hardware and the methodology to safely use this hardware in an efficient way. This goal was succeeded after five years and 50 million dollars. [71]

There are many different types of DGD methods. Therefore, it is difficult to track the development of DGD as a whole. This chapter is going to focus on the CML method within DGD. This system arose when a JIP was run under the Research Council of Norway's Demo 2000 program, where they examined the expansion of an existing pre-BOP DGD system for use in post-BOP operations. [70]

### 3.1.2 Principle of DGD

DGD enables drilling beyond the shoe depth limits of single gradient drilling [43]. With conventional single gradient drilling, the hydrostatic bottomhole pressure is a result from a single mud column from the rig to TVD (True Vertical Depth) with a single mud weight. The pressure gradients are referenced to the rig floor. With DGD, the bottomhole pressure is achieved with a combination of two fluid gradients; a lighter fluid in the riser from the mudline back up to the rig and a heavier mud in the wellbore below the mudline. Hence, the pressure gradients are referenced to the seabed instead of the rig. In this way, a pressure profile close to the pressure surrounding the wellhead is created. The resultant well-pressure profile matches the pore- and fracture pressure gradients better, which allows longer sections to be drilled and deepwater drilling can be performed with a lower risk. [43] [41] [42]

As mentioned, there are different approaches to achieve DG conditions [74]:

- A lighter fluid or gas can be injected in the riser or at seabed.
- The riser or part of the riser can be displaced with SW, while cuttings and mud are redirected to a pump at seabed and transported in a separate return line.
- A mud return pump can be mounted on the riser to lower the riser's mud level, leaving the top of the riser filled with air.
- A riserless application can also be used, where a suction module and an annulus return pump on seabed handling cuttings and mud returns before the marine riser is run.

[74]

Introducing DGD to conventional drilling rigs has given the opportunity to actively manage the hydrostatic pressure acting on the formation and selectively control the bottomhole pressure together with the pressure at any other point in the wellbore. This is achieved by the use of a subsea pump package together with a mud return line. Although the hydrostatic head in the upper hole sections can be reduced compared to conventional methods, the desired bottomhole pressure, defined by the pore- and fracture gradient window, can still be maintained. During disconnecting of the riser, the bottomhole pressure is maintained in the correct window without the need for overpressure at the BOP. [41]

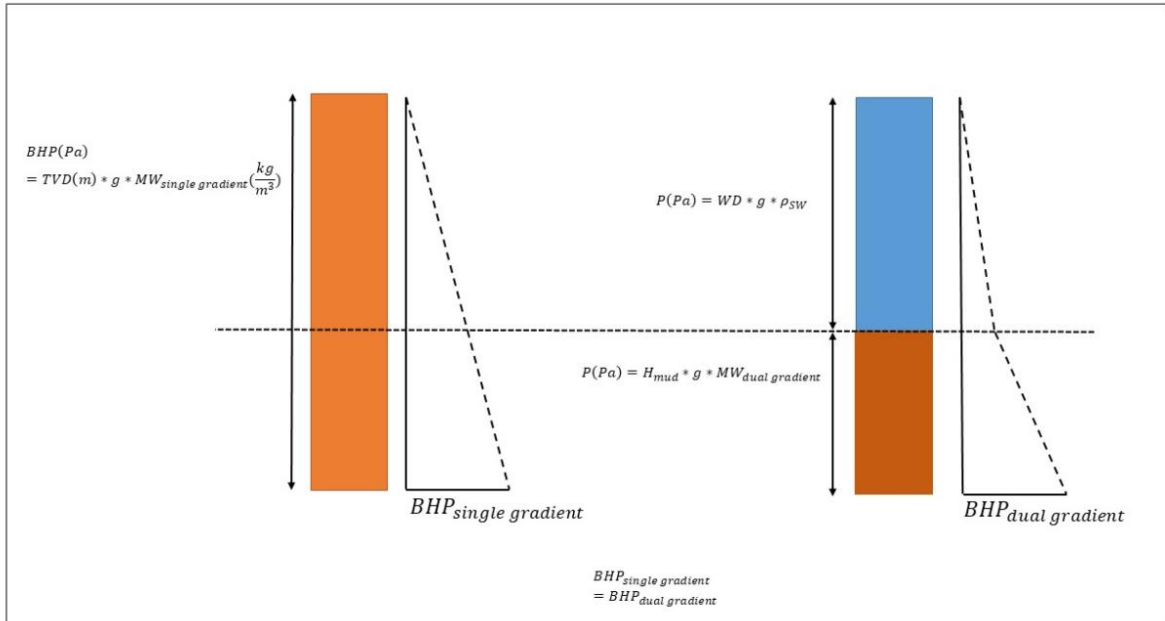

Figure 3. 2 Depiction of Wellbore Pressure Profile for Single and Dual Gradient Drilling, Inspired by [70]

### 3.2 Equipment

The EC-Drill™ technology needs extra equipment compared to the ones described in chapter 2, both subsea and surface equipment. They will briefly be described in the following.

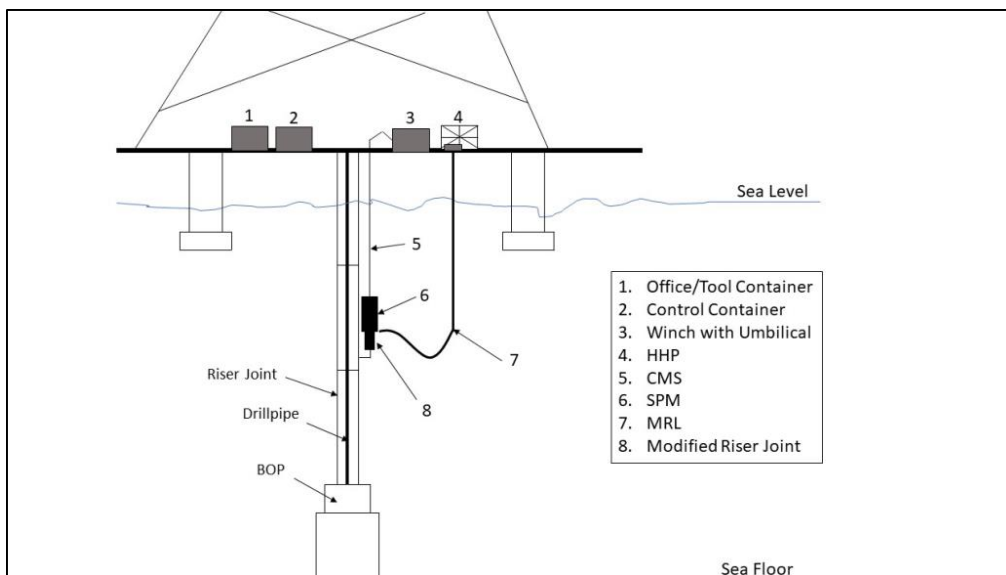

Figure 3. 3 EC-Drill Overview, Inspired by [46]

### 3.2.1 Subsea Equipment

- **SPM (Subsea Pump Module):**

The module is connected to the riser, and pumps with motors and other electrical and hydraulics equipment are integrated. The SPM also contains necessary sensors, valves and subsea control modules. It is the hub for sensor input and subsea control signals.

- **MRL (Mud Return Line):**

MRL is a return conduit for transportation of drilling fluid and cuttings to the rig. It can be a flexible hose hanging from the side, or a steel pipe conduit fixed on the riser.

- **MRJ (Modified Riser Joint):**

This riser joint includes isolation valves and acts as a tie-in point to the riser. The MRJ has sensors that communicate with the control system via the SPM and umbilical. It is designed to feed the subsea pump and to support the weight of the SPM.



*Figure 3. 4 Subsea Pump Module Placed in Launch System Prior to Docking to Riser [76]*



*Figure 3. 5 Modified Riser Joint, Shown with Subsea Pump Module During Interface Test [76]*

- **Riser Pressure Sensor:**

This sensor is placed on the MRJ and shows the atmospheric pressure plus the hydrostatic pressure of the mud column above the sensor. Hence, the volume and level of mud above this

sensor in the riser can be calculated from the pressure at the sensor. This pressure can also be used to calculate the pressure at any point in the wellbore, including the BHP, by the help from the hydraulics model.

- **Inlet and Outlet Pressure Sensor on the SPM:**

Additional sensors are connected to the subsea pump module and it measures the subsea pump suction discharge pressure.

### 3.2.2 Surface Equipment

- **OTC (Office/Tool Container):**

Holds the electrical equipment used to connect the EC-Drill™ system to the rig and other sensors. It also holds the control system and monitor interfaces. The pump operator can control and monitor crucial parameters from the OTC via the CMS (Control and Monitoring System). These crucial parameters include the electrical power used by the subsea pumps, riser pressure, suction pressure, rig pump rate, return flow, frequency and the position of the isolation valves.

- **CC (Control Container):**

This container houses the equipment for the SPM (Subsea Pump Module) power supply. Together with ventilation and air conditioning, gas detection system is also installed.

- **Winch with Umbilical:**

This power umbilical is used to transmit the required electric power to operate the motors on the SPM. It also transmits pressure data and signals between the SPM and the CC.

- **HHP (Hose Handling Platform):**

This allows a safe and smooth stationing of the MRL (Mud Return Line) Hose. When all hoses have been stationed, the last one is secured permanently at the hang-off point on the HHP.

- **CMS (Control & Monitoring System):**

Controlling the SPM to maintain the selected riser level and the desired return fluid rate are the main functions of the computerized CMS. To keep the mud level in the riser constant, the pressure in the riser is monitored and the VFD (Variable Frequency Drive), which is housed in the Control Container, is adjusted to change the speed of the subsea motors and pumps.



*Figure 3. 6 Umbilical Winch and Hose Handling Platform on Deck [76]*

[47] [46]

- **Top Fill Pump:**

This pump provides a constant flow from the top of the riser. The additional flow is used for lubrication of the riser and as additional safety if gas should accumulate in the riser, to ensure that no gas will reach the surface and ignite. The top fill pump provides mud and the nozzles spray mud on the drill pipe, like shown in figure 3.7, a mud wall barrier is created to stop the gas from reaching the drill floor. [45] The pump speed must be higher than the gas migration velocity. This pump also has the function of increasing the mud level in the riser if required.

- **Flowmeter:**

The flowmeter is installed at the MRL outlet and accurately measures the return flowrate from the mud return line. [45]

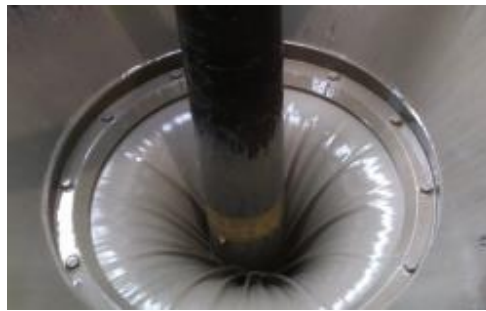

*Figure 3. 7 Liquid Mud Seal [45]*

### 3.3 Dynamics of the System

The EC-Drill™ system is an open to atmosphere system and it uses the subsea pump installed on the MRJ to change the mud level in the riser. The EC-Drill™ provides a dual gradient system by creating a void at the top part of the riser, so that the two gradients are mud and air. By manipulating the height of the mud level, it is possible to adjust the hydrostatic pressure in the wellbore and hence, controlling the ECD while drilling is possible. The EC-Drill™ technology also helps to reduce formation damage, makes it possible to evaluate pore- and fracture pressure gradient, and gives early kick and loss indication. The advantages will be discussed later in this chapter. [46]

Problems with getting the fluid column all the way back to the rig increases when the water depth increases because the hydrostatic pressure will be very high. With DGD, this problem has been

eliminated and significantly improved the drilling performance. Another problem is the dynamic pressure loss effect that occurs while circulating drilling mud through the wellbore for transportation of cuttings back to the rig. When the well is in a static condition, the mud weight has to be heavy enough to get a wellbore pressure higher than the pore pressure. The wellbore pressure increases when the mud pumps start and fluid is circulating in the well, this is because of the friction it creates. For deepwater wells, the margin between pore and fracture pressure is small. It is therefore a risk that the fracture pressure may be exceeded when circulation starts and results in lost circulation, which again may lead to a kick. This dynamic effect, ECD, is a drilling challenge that EC-Drill™ is able to eliminate. Lowering the riser's mud level compensates for the frictional pressure loss. Using this technology, the bottomhole pressure can be kept close to constant and the pressure changes between static and dynamic condition are very small, as one can see in figure 3.1. The system both controls the pressure precisely and via the riser pressure sensor, it detects small changes in the fluid column height and the flow. [48]

The fluid level in the riser is dynamically adjusted through the control system by the subsea pump. The pump accesses the wellbore below the conventional flowline. The circulating drilling mud is, at this point, sucked and pumped via a return line back to surface, as an alternative route back to the rig. [47]

EC-Drill™ can be run in different modes. With automatic mode, a chosen riser pressure is kept constant, the corresponding riser pressure is calculated and set as the riser pressure set-point. If a difference between the riser pressure and the set-point pressure occurs, the control system will increase or decrease the speed of the subsea pump so that set-point pressure is achieved. [47]

In automatic mode with constant bottomhole pressure, however, a constant bottomhole pressure is maintained by the control system and the system will compensate for the loss of friction when the driller stops the mud pumps. In manual mode, the EC-Drill™ is run at constant speed, and the riser level and return flow will be dictated by the mud weight in the riser and the pump output power provided.

When applying the EC-Drill™ method, a static overbalanced mud weight is to be used. EC-Drill™ can also be used in underbalanced conditions, however, if the circulation is planned to be stopped, the fluid level in the riser should be increased until static overbalance is reached. If the circulation unexpectedly stops, the annular preventer needs to be closed so that static underbalance can be avoided. Well specific procedure needs to be developed to ensure a correct operation. [48]

EC-Drill™ can be used on every rig, from fixed platforms to floating rigs, without the need of making many modifications. The technology can be used to drill two types of wells, which are [47];

- **Standard Wells**

In standard wells, the hydrostatic pressure of the drilling mud does not exceed the formation strength when the riser is full. However, the mud level in the riser must be lowered for ECD-control purposes if conventional mud density is to be used.

- **Special Wells**

Here, the hydrostatic pressure will exceed the formation strength when the riser is full and the level of mud in the riser should be below the flow line. This makes it possible to drill with a higher mud weight, “EC-Drill mud”, which closely matches the natural formation pressure gradient. The operational and well control procedures differ from conventional for special wells.

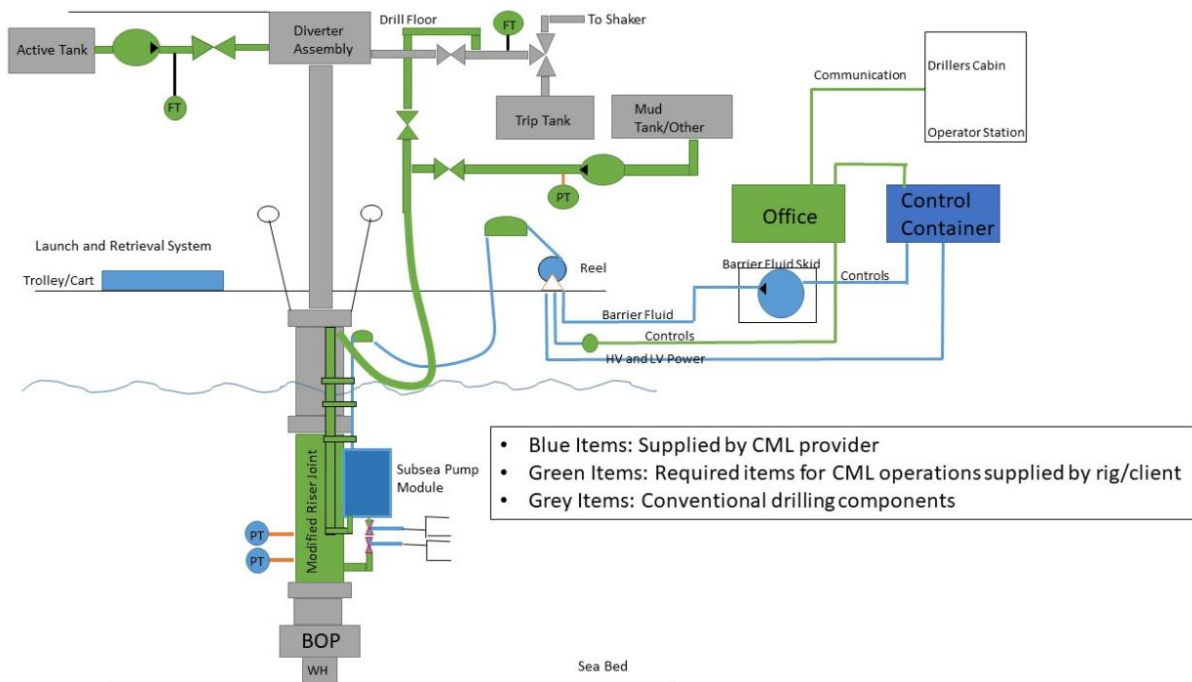

Figure 3. 8 Tool Configuration CML, Inspired by [75]

### 3.4 Pressure Control Principle

In the CML method, target pressure can be achieved by adjusting the mud level in the riser. Reduction of the fluid level in the riser can for instance be an effective way of omitting problems related to the fracture gradient and the ECD's in depleted reservoirs or extended reach wells. One can also circulate



with higher rates if cuttings transport is problematic. In addition, it is possible to maintain the same bottomhole pressure both during drilling/circulation and during connections. When the pumps are stopped, the fluid level in the riser has to be increased to compensate for the lost well friction. For instance, in [76], the riser level was 30 meters below the RKB during connections and 60 meters below RKB once full circulation is achieved. [76] The riser can be filled using for instance the top fill pump, boost line or by returning less fluid through the subsea pump than what is pumped in through the drillstring.

If a fixed mud level is to be achieved, a pressure sensor in the riser will monitor the hydrostatic pressure of the mud above and subsequently the mud level. The speed of the subsea pump will then be regulated in order to achieve this. [45] This is how the control system for the CML works.

The reduced mud level in the riser makes the average fluid density in the riser different from what the density is below the subsea BOP. Hence, effectively there are two fluid gradients in the well making this dual gradient system. The annular pressure profile is piecewise linear when measured in bar vs. depth and it forms a curved pattern when measured in s.g. vs. depth. The latter is beneficial since it will fit better in between the pore and fracture curves.

The graph below shows how the mud level is adjusted with time in a real well.

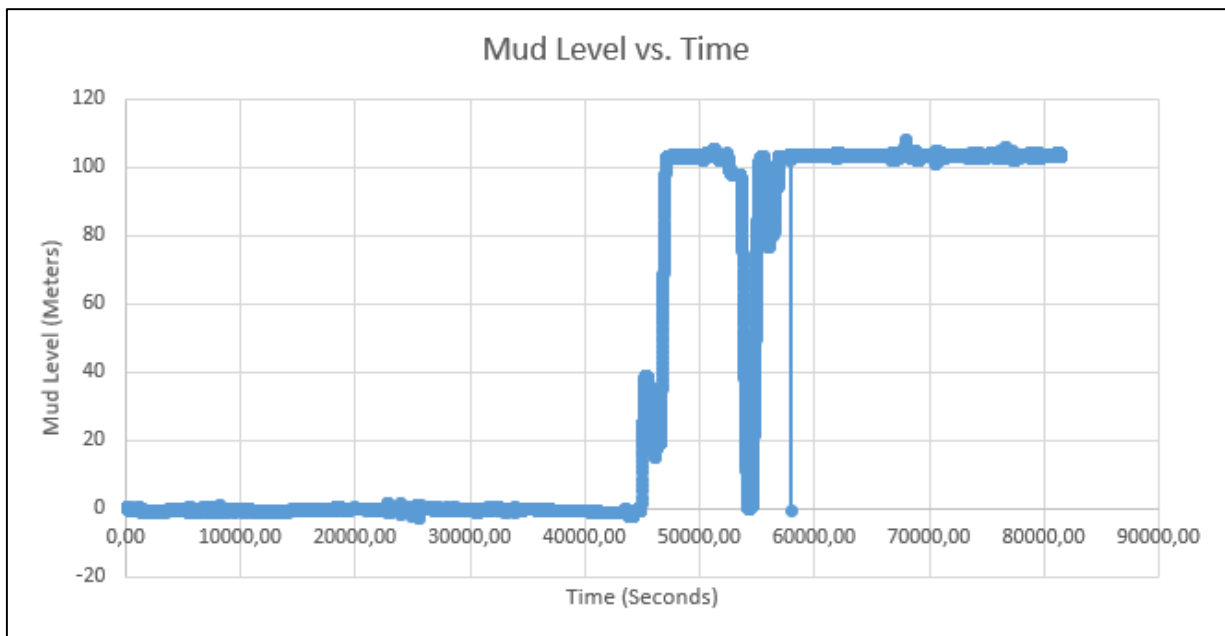

Figure 3. 9 Real Data of Anonymous NCS Well Drilled in 2017

### 3.4.1 The s.g. vs. Depth Plots

The following figures are graphical representations of the pressure profiles during conventional drilling and CML drilling, expressed in s.g.

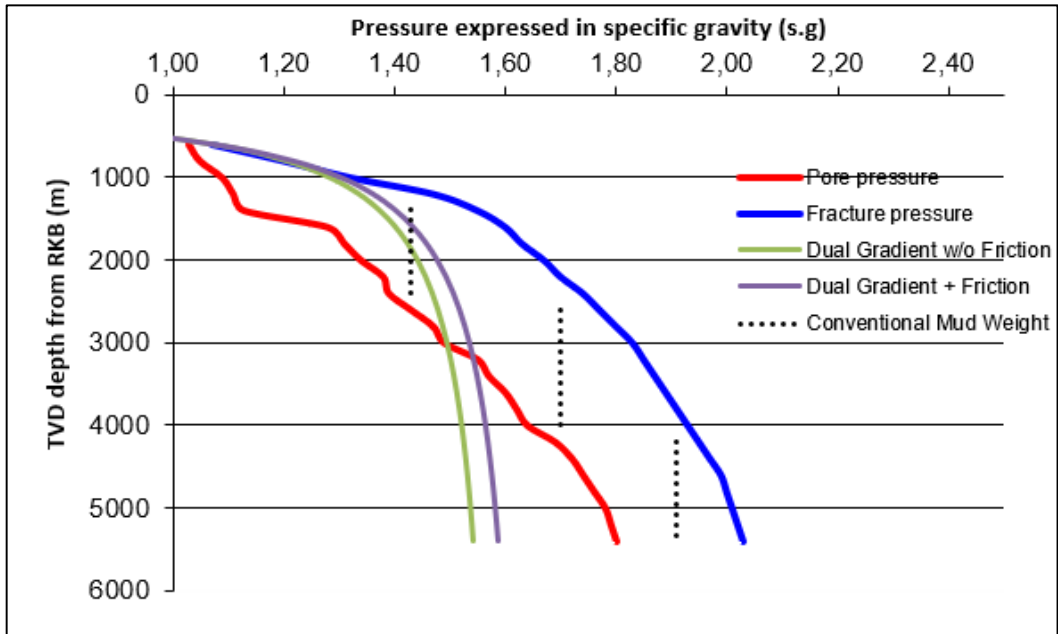

Figure 3. 10 s.g. vs. Depth, Low MW & High Riser Level – 200 m

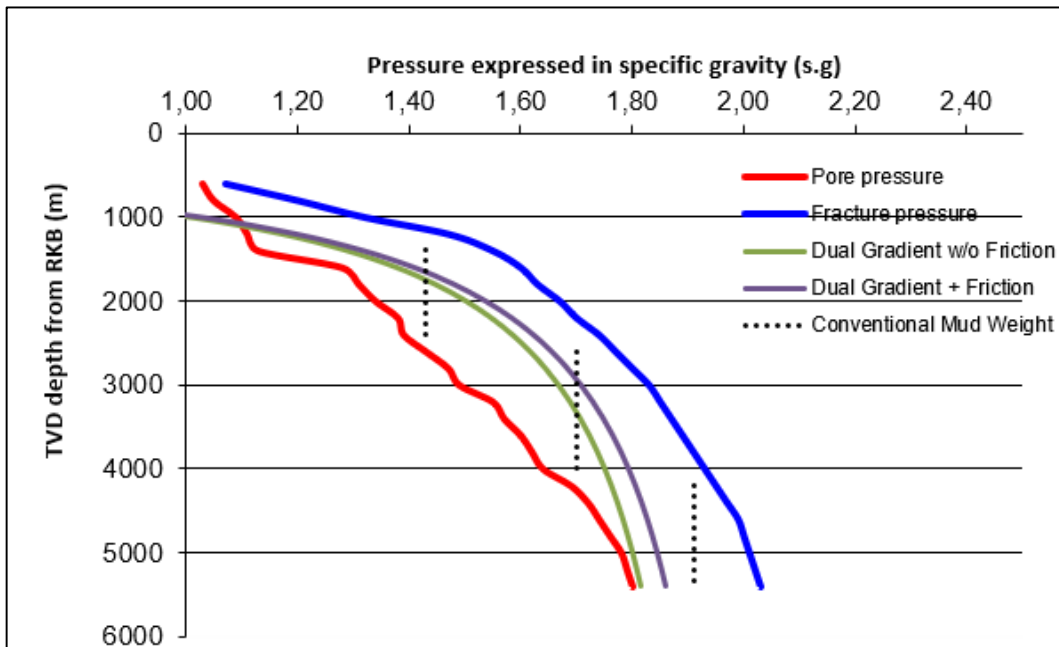

Figure 3. 11 s.g. vs. Depth, High MW & Low Riser Level – 500 m

Figure 3.10 has a 200 meter mud level from RKB and a mud weight of 1.6 s.g, whilst in figure 3.11, a mud weight of 2.0 s.g. is used and the mud level from RKB is 500 meters. A mud level of 500 meters is not commercial yet but is used here as a theoretical example to show the effect of changing the mud level in the riser. It is assumed that a 20" casing is set at 1200 meters.

From the graphs, it shows that the CML method gives curves that fit much better between the pore pressure and fracture pressure compared to conventional methods. From this it follows that it is possible to drill longer sections before setting a new casing when using the CML method. The vertical dotted lines show where one would have to set casings in the conventional case. It can also be seen that from lowering the mud level in the riser in figure 3.11, one can drill longer compared to the case in figure 3.10, where the mud level in the riser is higher.

### 3.4.2 The Bar vs. Depth Plots

The following figures are graphical representations of the pressure profiles during conventional drilling and CML drilling, expressed in bar.

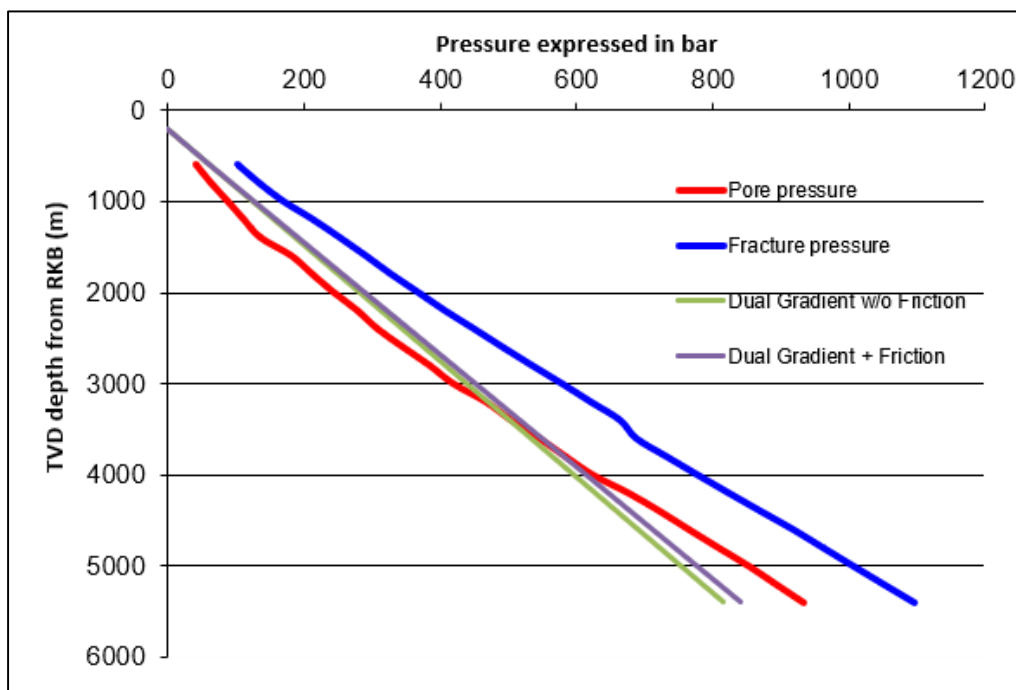

Figure 3. 12 Bar vs. Depth, Low MW & High Riser Level – 200 m

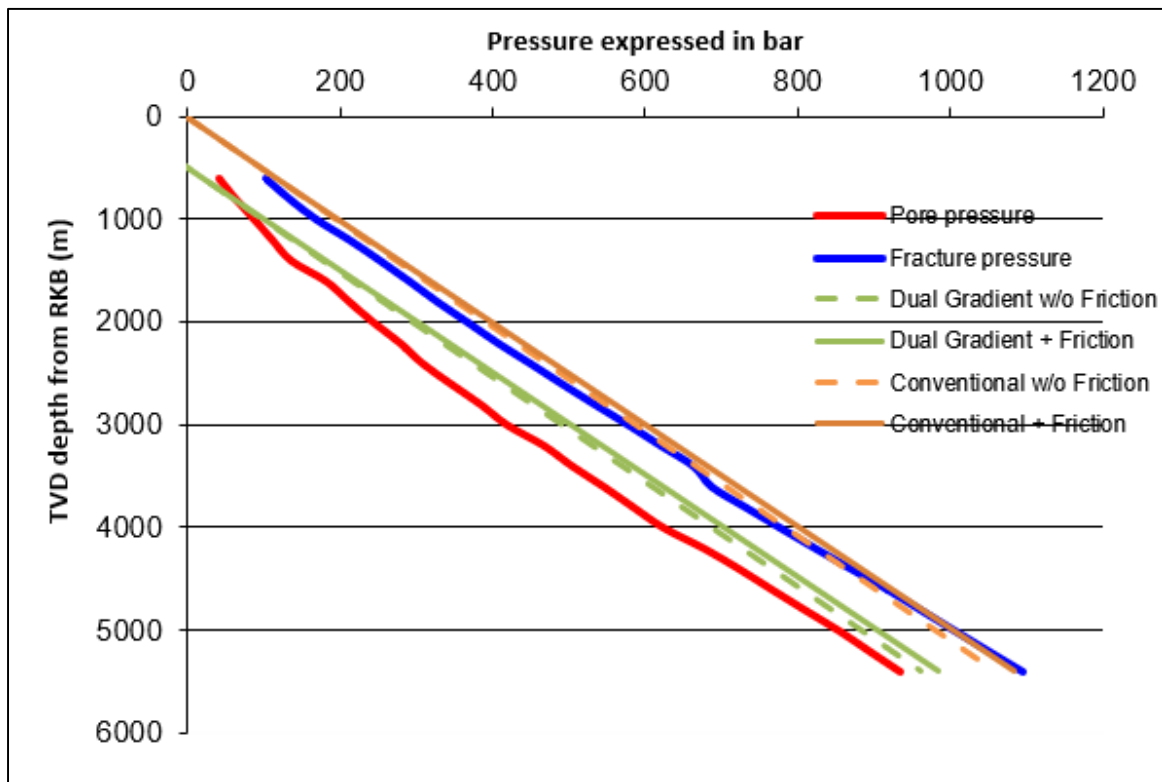

Figure 3.13 Bar vs. Depth, High MW & Low Riser Level – 500 m

Still, it is assumed that a 20" casing is set at 1200 meters.

Both figure 3.12 and 3.13 show that the mud level determines where the curve crosses the y-axis. This can be used to steer the well pressure profile better in between the pore and fracture pressure profiles. The slope of the well pressure line will depend on the mud weight (higher mud weight → lower slope). This will also impact how the curve fit in between the pore and the fracture pressure. Finally, figure 3.13 shows how one easily can adjust the pressure profile if the ECD or mud weight is too large by just lowering the mud level instead of changing the whole fluid system.

### 3.5 Barriers

This technology has the intention to improve the industry's way of managing wellbore and underground formation pressures more efficient, without having to sacrifice barriers and compromise well integrity. The EC-Drill™ was designed with better flexibility and ability to manage pressure uncertainties in the well than conventional drilling. It was, however, designed with the same barrier and well control principles as in conventional drilling. Hence, it is an open system, as conventional drilling, so that all type of tubular and equipment can be run into the well. [45]

The well barrier diagram is the same as in conventional drilling because the primary barrier is the drilling mud and the secondary barrier is the subsea BOP. The riser isolation valves can be closed if needed at any time during the operation; the riser fills up and conventional drilling can be applied. Here comes an overview of the barriers [50]:

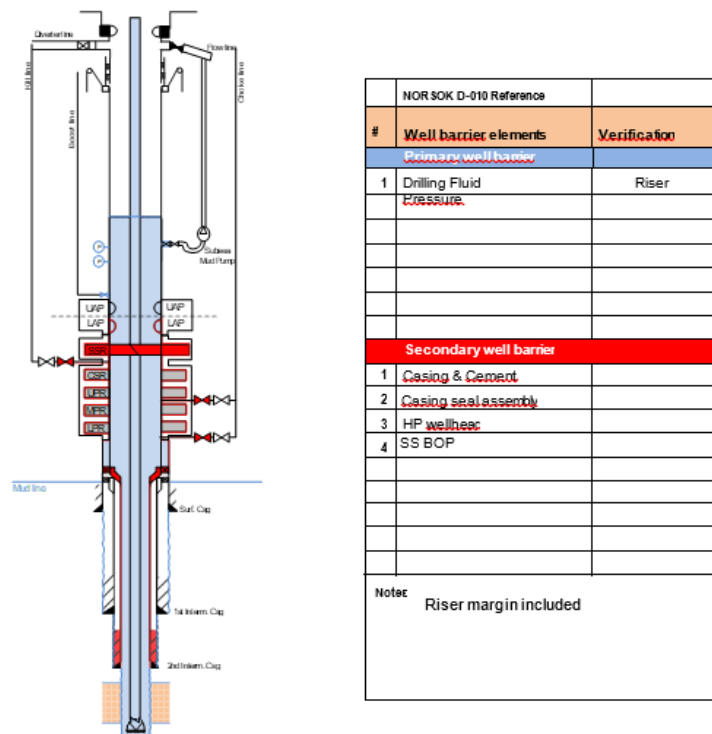

Figure 3.14 Well Barrier Schematic for CML [12]

The figure above shows the barrier program for an exploration well drilled in the Barents Sea, with a formation consisting of naturally fractured and weathered carbonate. [76] With the CML system, the

drilling fluid should always be in overbalance, so that if the pumps are stopped, there will be no influx from the formation.

### 3.6 Well Control

The pressure regime when using the CML method will almost be the same as for conventional drilling, except the use of a lower mud level in the riser and a heavier mud. The pressure in the mud/air interface in the riser will be close to atmospheric pressure. This is an advantage as it makes it possible to compensate for the ECD-effect and to adjust the BHP quickly. Higher circulation rates are allowed when using the CML method. This is because the limitations caused by the highly increasing annular friction pressures are being neutralized. [72] The CML method was designed to have the same well control principles as conventional drilling. If a kick is taken, the BOP will be closed and conventional well control procedures will be followed. [45]

With the higher mud weight and the lower mud level in the riser, the possibility for a riser margin in deepwater wells is introduced. Utilizing the CML method can, in many cases, result in a positive riser margin, which means that the well will stay overbalanced also in the case where a riser disconnect event takes place. It is difficult to include a riser margin in most conventional deepwater drilling. [72]

#### 3.6.1 Kick Detection

One of the main benefits of the CML system is early kick detection and improved volume control. By keeping an eye on volumes, flows and pressures, it is quite easy to detect a kick when everything should be in steady state. However, 70 % of all kicks are taken when connections are made and many drilling parameters are changing at the same time. During a connection, the pumps are ramped down to zero and the bottomhole pressure has its lowest value because there is no flow up the annulus that is adding friction. [73]

To measure the return flowrate from the MRL, an accurate flow meter is installed at the MRL outlet. In addition, the pump controller will respond quickly to flow variations. These measurements enable early detection of influx and losses. The MRL will always be full of mud, which will result in continuous flow measurements with improved accuracy. Adjustments to the well's pressure profile can be made, by adjusting the mud level in the riser, if losses are detected. In conventional drilling, it is not possible to make these types of changes. [45] The principle is that one decides a certain level for the fluid in the

riser, this fluid level will correspond to a certain hydrostatic pressure on the pressure sensor in the riser. The rate from the subsea pump will be adjusted so that this pressure, i.e. riser level, will be kept constant. When a kick occurs, the volume and the fluid level in the riser will increase, which will lead to an increased pressure on the sensor before an increased flowrate from the pump follows to try to adapt to the decided pressure/fluid level. This will also show on the Coriolis flowmeter on the outside of the MRL and then lastly in the active pit tanks. Hence, kicks and losses can be detected early.

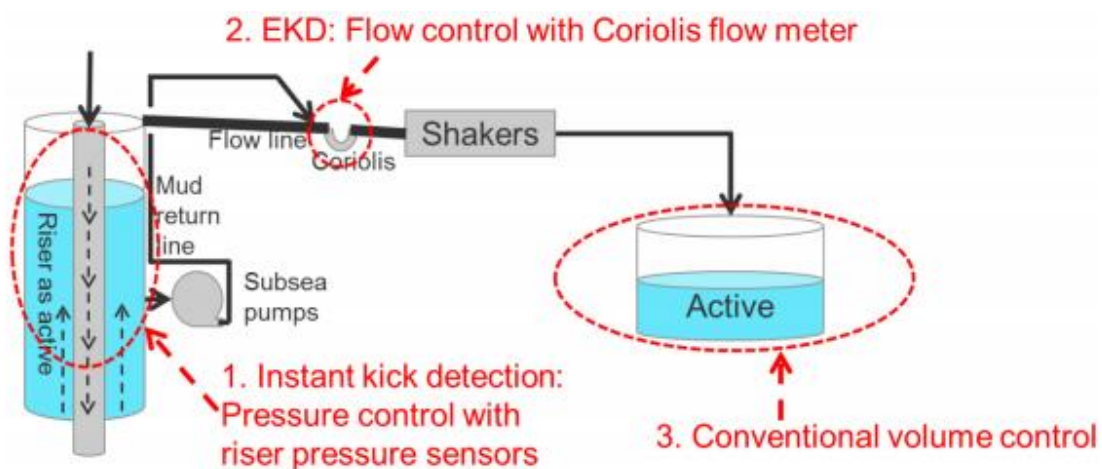

Figure 3.15 Three Levels of Volume Control [73]

Figure 3.15 shows how the riser pressure and pump speed, can provide instant kick detection as an influx or a loss can be seen here before being measured by the Coriolis flow meter and the level sensors in the active system. The first indication is an increase in the riser pressure followed by the second indicator, which is an automatic increase in the pump speed and an increased return flowrate. The third level is conventional volume control based on pit volumes. [73]

A reduction in the riser level can be interpreted as a kick as variations in the riser level have an impact of the total volume control. E.g. a 600 ft (183 m) reduction in riser level will give an increase of approximately 200 bbls (32 m<sup>3</sup>) in the active pits on the rig. To take this into account, the riser can be added as an active pit by using EC-Drill level calculation based on the riser pressure sensors. This will also improve the capability of kick detection based on volumes because an increased return will give an almost immediate increase in the riser. When conventional, the added volume must propagate down the topside lines before it can reach the active pits. These measurements of the level in the pits are very

accurate, but they are influenced by rig tilt and motion. Due to this, the measurements are sometimes filtered to reduce the natural variations, which takes time and can delay detection of volume instabilities in case of a kick. However, the volume changes in the riser will be unaffected by rig movements, which is an advantage.

### 3.6.2 U-Tube Effect and Fingerprinting

When the rig pumps are stopped the U-tube effect from the drillstring can make it difficult to distinguish an influx from the flow taking place due to hydrostatic imbalance between the drillstring and the annulus during connections. The solution to this is fingerprinting. The CML technology is equipped with a fingerprinting function that detects gain and losses when U-tubing is present. This is done by comparing the current trend (parameters changing in time during the connection) with the last saved trends at previous connections. If there are any deviations, the operator will receive a warning. The following figure shows an example of fingerprinting during a connection. [45]

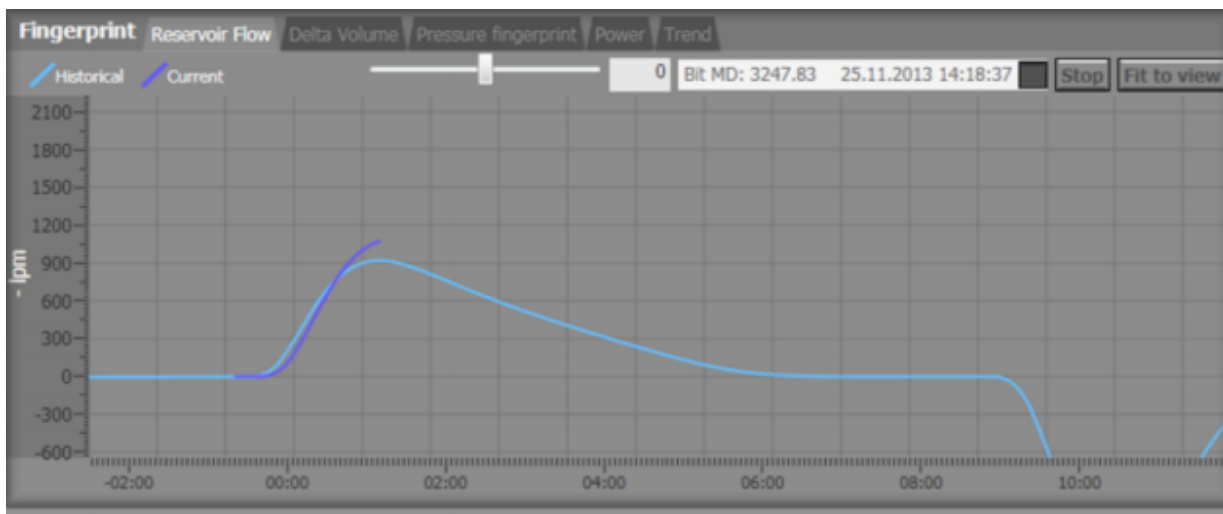

Figure 3. 16 Fingerprinting Functionality [45]

The light blue line shows the recorded baseline for flow back from an earlier connection and the dark blue line shows the real time signal. These two lines are the lines that are compared to each other and one can see that the dark line deviates from the light line around one minute after the rig pumps are stopped. This is probably caused by an influx and by fingerprinting the accumulated volume and the flowrate, one gets an overview of the volume in the system during connections. [45]



### 3.6.3 Gas Kick Migration Velocity

If a kick occurs, an important question to answer could be how fast the gas rises. This is because the migration velocity will affect how fast the pressure in the well builds up, if the system is closed. This velocity will affect when the kick is arriving at surface and can affect how the gas is distributed in the well, which again can affect the calculations of kick tolerance. Knowing the migration velocity is important when planning a bullheading operation. The minimum liquid rate must be higher than the gas kick migration velocity. In the CML method, one has installed a top fill pump in case some gas should migrate into and accumulate in the riser while drilling. [45] The downward flow velocity caused by the top fill pump should be larger than the gas migration velocity to avoid gas to surface. In addition, the mud is sprayed into the annulus to form a liquid seal. [45] In the CMCD method developed for handling severe losses, one was also concerned with gas migration of potential kicks. Hence, continuous annulus injection was required here. [76] In case total mud losses occurred, the idea was to pump down from both the top fill and the boost line to ensure that kicks did not migrate up from the reservoir.

The following equation (Zuber and Findlay, 1965) shows the gas slip relation [69], which can be used for estimating required rates to overcome gas migration:

$$V_g = K * v_{mix} + S = K * (v_l \alpha_l + v_g \alpha_g) + S = K * \left( \frac{q_g}{A} + \frac{q_l}{A} \right)$$

Where:

- $q_g$  and  $q_l$  – Volumetric flow rates for the gas and liquid phase, respectively.
- $K$  – Parameter related to the distribution of the gas across the pipe or the annulus.
- $S$  – Gas rise velocity, which represents the velocity of gas relative to liquid.
- $v_g$  – Gas kick migration velocity
- $\alpha$  – Volume fraction
- $A$  – Cross-sectional area

The flow regime in the well will affect the  $S$  and  $K$  values. The flow regime is dependent on the volume of gas in the well. The different flow regimes for non-Newtonian fluids, such as drilling fluids, are bubble, slug, dispersed bubble, churn, annular flow and the gas bubbles can be trapped in the mud when lower gas concentrations are present (lower than 10%). When the gas bubbles get trapped, there will be no slip conditions, i.e.  $K=1$  and  $S=0$ . In some cases, the kick can come fully suspended and will then only arrive to surface when it is circulated out. Because of this, the interpretation of the wellhead pressure during

shut-in can be misunderstood as a slow gas migration velocity. In 2005 (Rommetveit et al.), a riser field test was done using multiple sensors in the well for a better approach for measuring gas migration velocity. [104] It can be mentioned that when considering gas migration velocities and the CML method, there were some discrepancies between what the theoretical models said and what supposedly had been seen in operations. This discussion can be seen in [76].

### 3.7 Controlled Mud Cap Drilling (CMCD)

In [76], one has taken the control system a bit further. The CMCD (Controlled Mud Cap Drilling) system has been developed to handle severe losses that can take place during drilling of Karst. The system employs basically the same type of equipment as CML, but the control system is different. In this case, the objective is to control the filling of the well in case of severe losses such that mud level still remains stable. So here one controls the annulus injection rate (top fill + boost line – return flow) based on the measurements of the mud level (i.e. pressure readings) in the riser and a predetermined injection rate that is well dependent. In CMCD mode, the control is based on the return flow delivered by the subsea pump. [76] The following is a figure of the CMCD barriers.

- **Primary Barrier Envelope**
  1. Drilling fluid
  2. Drill string, BPV (Back Pressure Valve)
- **Secondary Barrier Envelope**
  1. Casing and Cement
  2. Casing seal assembly
  3. HP Wellhead
  4. SS (Subsea) BOP
  5. Drill string, BPV

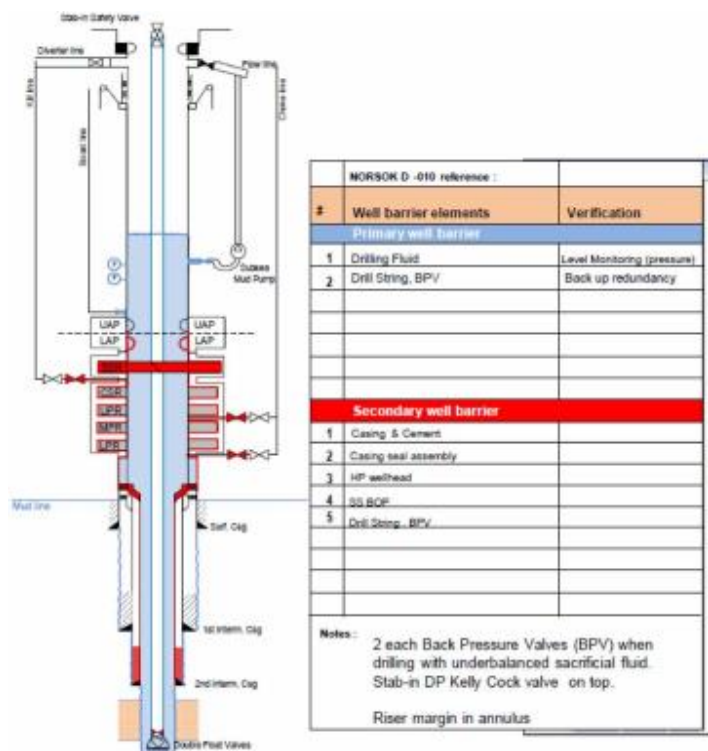

Figure 3. 17 Well Barrier Schematic for CMCD [76]

## 3.8 Case Studies

### 3.8.1 Offshore Cuba, Gulf of Mexico

The world's first successfully ultra-deepwater well drilled with the CML method was drilled from May to July in 2012 in the Cuban water of the GOM. [46] A previous attempt in GOM to drill an exploration well in ultra-deepwater did not reach its target due to total loss of circulation. The reason for this was that they used the CBHP method and were not able to have a drilling fluid that was light enough to manage the AFL (Annular Friction Loss) with the added backpressure that had to be applied. [44] The naturally fractured carbonate reservoir started to take fluid when circulation started. Usually when circulation stops or the ECD drops, an annular backpressure can be added. However, this first exploration well had a very low reservoir pressure and did not allow for any surface backpressure. Together with 2D- and 3D seismic data, well data and log information from the first well predicted that the same structure of the reservoir, with much cavities, would be found in the second well of this campaign. To reduce the risk of severe loss, Enhanced Drilling introduced the EC-Drill™ technology. [47] The project started in 2011 and was to be used on Saipem's Scarabeo-9 MODU (Mobile Offshore Drilling Unit), a new-built sixth generation semi-submersible drilling rig. Based on the previous offset well, the EC-Drill™ system was considered the tool to reach the planned target depth. The system was specifically designed for the Scarabeo-9, it was designed in the final stages of construction and commissioning in the Keppel FELS shipyard in Singapore. The delivery of the system occurred during October and the installation took place over a two-month period, while Scarabeo-9 transited from Singapore to the GOM. [46]

The second exploration well was located at 1778 meters water depth, 50 km away from the first well. The objective was to reach the total depth at 4830 meters for calibration of seismic data, formation evaluation and collection of geological data in the carbonate reservoir. The EC-Drill™ system was only considered for drilling 630 meters of 8 ½" hole into the reservoir, but the system was tested successfully and it was possible to use it for drilling 17 ½" and 12 ¼" hole sections as well in case of an event of severe losses. [47]

The CML method that was successfully applied on a well in 2012 had a water depth of 2260 meters and the formation was generally carbonates, which has the potential of severe losses. The ECD effects were eliminated. When the riser was run, the EC-Drill™ pump was launched and attached to the riser for the last 400 meters. The riser level was decided after PWD readings and was maintained between 150 and

200 meters below flowline during drilling of the 17 ½” hole section. The riser level was kept constant during connections. During connections in the 12 ¼” section, the riser level was raised 50 meters to account for the reduced BHP when the rig pumps were shut down. Some gas bearing formations were penetrated with a reduced riser level in this section and no gas was seen in the riser top. The drilling of the reservoir section had no losses and the hole was in good condition with no indication of fill or drag. [46]

### 3.8.2 Statoil, Norwegian Continental Shelf and Gulf of Mexico

In 2013, Statoil selected CML for a drilling campaign in the GOM. [73] [106] The objective was to qualify the CML and demonstrate its ability to improve drilling process in deepwater wells. The following table summarizes Statoil’s testing criteria to use the CML system in this drilling campaign with the Maersk Developer rig. [73]

No	Activity	Accepted
1.	Able to control riser pressure within +/-75 psi	V
2.	Enable early kick detection	V
3.	Operate with conventional well control	V
4.	Verify methodology to avoid gas in riser	V
5.	Volume control during operation	V
6.	Stable riser level control	V
7.	Verify control system functionality	V
8.	Verify ECD table calculations	V

Figure 3. 18 "Statoil Success Factors" [73]

In 2014, two Statoil wells at the Troll field on the NCS was successfully drilled with the EC-Drill™ technology. The first well was then plugged and used for 48 hours of several control tests. Each test was designed to determine the functionality of the system. They tested how to detect and handle losses and influx, gas migration in the riser and circulation of gas through the SPM. All these tests were performed with reduced riser level and as an open system to determine how the system could detect volume imbalances while drilling. [70] The reason that the EC-Drill™ method was used here was because the Troll field is a very mature field and has a narrow window between pore pressure and fracture pressure. Hence, it was not possible to use a mud weight with low enough density to reach TD with the

conventional method. Utilizing CML, there was no need to change to a lower mud weight, because the pressure could be lowered by having a lower mud level in the riser. In the second well, reducing the ECD during operation allowed drilling through a fracture zone and extended the horizontal section by an additional 1500 meters. After the commercialization and implementation of EC-Drill on the Troll field in the summer of 2017, 2 record wells of more than 8000 meters MD have been drilled with the Songa Equinox rig, in December 2017 and January 2018. The following graph is from the Troll Pilot Well drilled in 2014 and shows loss reduction given in volume. [106]

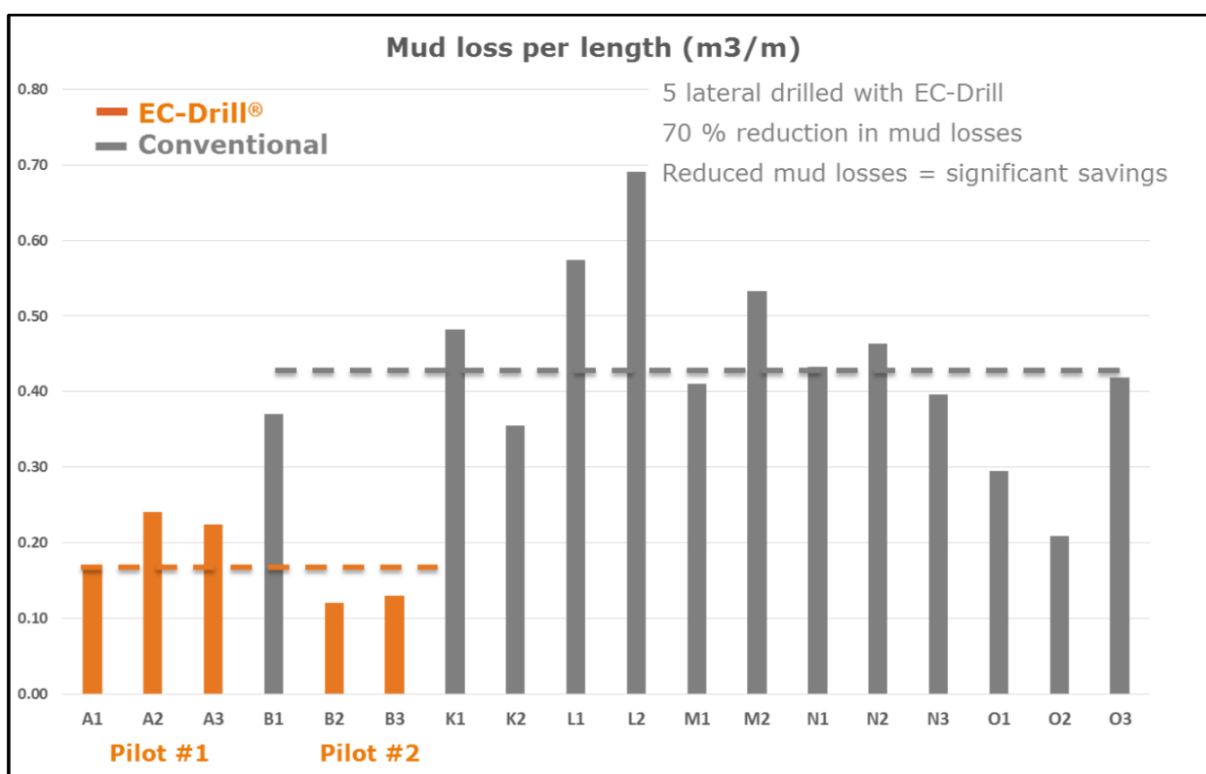

Figure 3. 19 Loss Reduction in Volume [106]

### 3.8.3 Lundin, Barents Sea

In the summer of 2015, an exploration well was drilled in the Barents Sea from a semi-submersible drilling unit. Severe mud losses occurred during coring of the 8 ½” hole in the reservoir formation, which consisted of carbonate. The rig crew was not able to keep the riser full of mud, so the well had to be shut

in with the subsea BOP. Various concentrations of LCM (Lost Circulation Material) pills were pumped in as an attempt to cure the loss zone. However, gas started migrating up the annulus and the annulus had to be bullheaded with a high viscous mud pill followed by seawater to reduce the casing pressure. 23 LCM pills were pumped down the drillstring in total, this without any signs of improvement with regards to losses. To enable further data acquisition, a sidetrack was drilled from the actual well. The TD for the sidetrack was set above the karstified zone. After investigating this well control incident, several of MPD and mud cap drilling methods were evaluated. CML and CMCD were deemed to be the most robust solution to be used on a floater in a harsh environment. Late in the summer of 2016, a re-entry of the exploration well was planned to be drilled in the same region with the Leiv Eirikson rig. Karstified carbonate was expected in the 6" section of the well. It was decided to prepare the rig for use of the CML and CMCD technology as a risk mitigation tool and to test out the principles and procedures. The main reason for choosing the CML technology was to reduce the risk of mud losses. The plan was to introduce the CMCD method if an event of total mud losses would occur, to control the situation. The well had a water depth of 412 meters. The plan was to always be statically overbalanced with the highest predicted pore pressure in the reservoir because there was an uncertainty as to the reservoir depth, content, pressure at the top of it and potentially being karstified. The 7" liner was drilled conventionally and the 6" hole was drilled with the CML system down to the top of the reservoir, having the riser level at 30 meters below the RKB during connections and 60 meters below RKB while circulating. Once the reservoir top was confirmed and coring started, the riser level was reduced to 80 meters below RKB during circulation. No significant losses were encountered. However, very accurate and instant loss detection was proved as very small losses were clearly detected by the CML system which corresponded with coring through natural fractures in the carbonate reservoir. These losses were cured with the mud itself and did not require any LCM materials and no CMCD drilling procedures were practiced, as no open karsts or large fractures were encountered. [76]

Following this initial well in the Barents Sea, 8 additional wells have been drilled in the 2016-2018 using the CML technique. CML has been used in varied operations, such as drilling 17 ½" to 6" hole, under reaming, coring, wireline, cementing liner and casing, setting kick off plug providing added efficiency and more accurate volume control. [105]

### 3.9 Challenges and Benefits

There are many advantages by using the EC-Drill™ technology and there are some challenges as well, both the advantages and the challenges will be described in the following.

#### 3.9.1 Compensate for the ECD Effect

EC-Drill™ operations can, as mentioned earlier, compensate for the ECD effect by lowering the fluid level in the riser. This can be very useful in depleted fields where there is not possible to change to a lower mud weight without going lower than the pore pressure gradient. The fluid level can also be increased to keep the pressure constant during circulation or connection. However, a certain amount of water depth is required to be able to achieve this. The ECD component is dependent on the length of the well, the type of fluid, density and circulation rate, among other things. On the NCS, the ECD component will typically vary between 20 to 50 bars, which will require a water depth of 200-300 meters to be able to fully compensate for this effect. Since EC-Drill™ can compensate for the effect of ECD, one is able to drill with higher rates than it is possible with conventional methods. Hence, the hole cleaning is improved, buildup of cuttings bed in deviated wells and pack-offs are avoided, one may also be able to drill faster (higher ROP) due to the possibility of compensating for cutting loading. The ability to compensate for the ECD effect will permit longer wells to be drilled, increase the drainage area of the reservoir and make it possible to reach new, conventionally unattainable targets. This can be a great advantage when dealing with mature depleted fields, like Troll, where it is difficult to have a sufficiently low mud weight. Another application area is extended reached drilling. [45]

#### 3.9.2 Early Kick Detection

One of the main benefits of the EC-Drill™ is early detection of gains or losses and improved well control. To measure the return flow rate from the return line, an accurate flow meter is installed. In addition, the pump controller responds fast to flow variations. With these measurements, an influx or a loss will be registered more accurate and much earlier than with the conventional setup. The return line will always be full of mud, which results in continuous flow measurements. If a loss is detected, the pressure profile in the well can be adjusted by changing the riser level. In addition, no influxes or losses are being camouflaged by heave motion due to the riser acting like a pit gain. [45]

### 3.9.3 No Need to Modify the Riser System

Another major benefit of EC-Drill™ is that the surface components of the riser system do not need to be modified; this means that the rig's weather capability is not changed. [46]

### 3.9.4 Possible to Drill Longer Hole Sections

As mentioned before, the system is able to keep a constant BHP and to keep the wellbore pressure within the operational window since the riser level is being controlled with the control system. Because of this, there is no need to keep changing the mud weight while drilling and a lot of NPT is avoided. The natural pressure gradients are better matched with EC-Drill™, which makes it possible to drill longer hole sections. Because of this, the number of casing strings necessary to complete the well can be reduced. It can make it possible to reach depths that were impossible to reach in a conventional manner. [45] This can be especially useful for deepwater applications where it can be a problem to reach TD since all casings have been used before reaching target.

### 3.9.5 Avoiding Mud Losses

In conventional riser operations, an unplanned or emergency disconnect leads to a sudden mud loss in the riser, which will reduce the hydrostatic pressure and resulting the wellbore to be in underbalance. A kick will then occur if the BOP does not function in time. [45] If one experiences mud losses, one can quickly decrease the pressure by lowering the mud level in the riser. This is a big advantage compared to conventional drilling, where the mud needs to be changed to a lower mud weight, which takes a lot of time and is expensive. In addition, the CMCD method has been developed from the CML technology as an alternative to Pressurized Mud Cap Drilling to be able to handle drilling in karst where severe mud losses can occur. [76] In addition to karst formations, problems with losses may occur in depleted field, as Troll, where there is no option of using lower mud weight.

### 3.9.6 Riser and Trip Margin

With a dual gradient system, the riser margin is always present. *"A riser margin is the additional fluid density required to compensate for the differential pressure between the fluid in the riser and seawater, in the event of a riser disconnect."* [45] [49] With EC-Drill™, trip margin can be initiated in minutes by



adjusting the fluid level. Circulation is not required. Hence, tripping can be more efficient. *“Trip margin is the additional fluid density required to compensate for swab effects when pulling out of the open hole.”*

[45]

### 3.9.7 Challenges

Since EC-Drill™ periodically will operate with a lower riser level, U-tubing can be a problem that does not exist in conventional drilling.

During connections, or other circulation stops, the hydrostatic pressure imbalance between the drillstring and the annulus may lead to U-tubing and result in mud flow from the drillstring into the annulus. It can be difficult to distinguish this effect from a kick influx. To help solve this challenge, the EC-Drill™ system is equipped with a fingerprinting function. The idea behind this, is to first map what is the “normal” behavior during U-tubing and use this information later to detect abnormal situations when the conditions are otherwise the same. This function monitor gains and losses when U-tubing is present. The fingerprinting detection mode compares the last saved trend with the current trend, and if any deviations occur, a warning will appear to the operator. It is therefore very important that the driller follows the same pump ramp schedule at every connection. [45]

## Chapter 4 – Pressurized Mud Cap Drilling (PMCD)

PMCD is an MPD technique that is used to control wells with heavy losses. PMCD allows drilling to continue with losses, without having large drilling mud costs associated with these losses. Extreme losses are a challenge in conventional drilling but is turned into something positive in PMCD; better well control, higher ROP and reduced mud costs, among others. The PMCD technique is often used in carbonate structures and uses the carbonates natural highly fractures or caves to swallow the drilling fluid and cuttings. Example of karst structures can e.g. be found on Svalbard, as can be seen in Figure 4.7. Rather than trying to cure the losses with LCM, the PMCD method uses a weighted mud cap, called LAM (Light Annular Mud), in the annulus to keep the pressure in the reservoir in balance. Simultaneously, SAC (Sacrificial Drilling Fluid) is pumped down the drill pipe. There are no returns to the surface as all the cuttings and SAC are lost to the formation. Minor losses are fixed conventionally with LCM and when the losses reach unmanageable levels, the operation change to PMCD. [89][91]

*According to IADC, PMCD is defined as “A variation of MPD, drilling with no returns to surface where an annulus fluid column, assisted by surface pressure, is maintained above a formation that is capable of accepting fluid and cuttings. A sacrificial fluid with cuttings is accepted by the loss circulation zone. Useful for cases of severe loss circulation that preclude the use of conventional wellbore construction techniques.” (IADC, December 2011, [95])*

PMCD is one of three MCD (Mud Cap Drilling) variations. The other variations are called FMCD (Floating Mud Cap Drilling) and DMCD (Dynamic Mud Cap Drilling). In FMCD the mud cap fluid “floats” in the annulus and the well is open to atmosphere at surface, thus eliminating the need for an RCD and other equipment. The hydrostatic pressure of the mud cap fluid itself is sufficient to balance the formation pressure. In DMCD, mud cap fluid is continuously injected into the annulus and is used in cases where FMCD and PMCD are not feasible. For instance, if the formation is highly underpressurized and FMCD is unsafe, or if PMCD requires too many bullheading operations, this method is preferred. [94]

Since all methods have no returns to surface, the fluid column in the annulus can be divided into four zones which will be explained in the following, starting from the top of the well. Part b) of the figure below also shows these zones. [94]

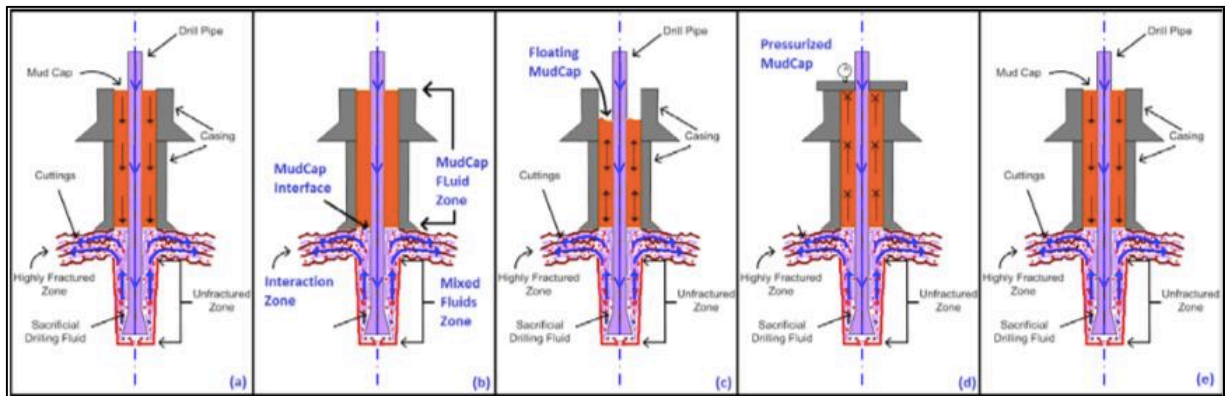

Figure 4. 1 MCD Variations and Zones [94]

**MudCap Fluid Zone:** This zone consists of the MudCap Fluid, called LAM. It is common that these fluids have high viscosity in order to restrict fluid migration. [94]

**MudCap Interface:** The interface is a dynamic boundary between the MudCap Fluid Zone and the Interaction Zone. It depends on e.g. downhole dynamics, surface dynamics and changes in the rig operations. [94]

**Interaction Zone:** This zone is where the fluids interact with the formation. The formation here is characterized by fractures, caves etc. and is capable of accepting the SAC fluid, drilled cuttings and eventual formation fluids from other flowing zones. [94]

**Mixture Zone:** The mixture zone consists of a mix of fluids, e.g. drilled cuttings, formation fluids and drilling fluids. [94]

#### 4.1 Historic Development of PMCD

The term *mud cap drilling* has been widely used for a long time and was first applied around year 2000 in the Austin Chalk fields, in Central and South Texas. This was fractured carbonate that was drilled with horizontal wells. Depending on the mud weight and the pore pressure, either a kick was taken or circulation was lost when the first of the fractures was experienced. The fracture could not be balanced statically and dynamically, simultaneously. In the beginning, it was attempted to plug the fractures with LCM, but this was impossible in many cases. Drilling then had to be continued underbalanced. To maintain circulation and to control the influx, the mud weight and/or the choke pressure was adjusted. Deeper in the well, the pressures got higher and the production was gas. Hence, things got more

complicated but there was still only one open fracture, or the open fractures were close, so it was still possible to adjust the mud weight and the choke settings to the point that the surface pressures and production rates were manageable. However, it was when several, widely spread fractures occurred along the horizontal wellbore that things got really complicated. It became impossible to maintain circulation while balancing all the fractures because of the differences in wellbore pressure caused by the friction from circulation. The multiple fractures were exposed to different ECDs and mud losses were experienced, which made the operation very time consuming and expensive because of all the heavy mud lost to the formation and all the time spent on circulating instead of drilling the hole. Mud cap drilling, in this case Floating Mud Cap Drilling (FMCD), was developed to reduce the losses of mud and time and was first used in a simple form where kill mud was bullheaded down the annulus until the well was in vacuum. Then, drilling continued with fresh water pumped down the drill string and no returns to the surface. The well would periodically kick and more kill mud had to be pumped down the annulus until there was vacuum in the well again. When drilling like this, quite a lot of mud was lost, but compared to the amount lost to the hole and the time spent on circulating when using the conventional method, it was a lot less. [7]

When this technique was applied to formations with very wide fractures, the next step of mud cap drilling, PMCD, was developed. Another reservoir contained either oil or gas with a very different hydrostatic gradient compared to the drilling fluid, so simultaneously balancing fractures separated by a significant vertical distance was impossible. The same method used in the Austin Chalk was considered, but the formation was quite sour and this gas could not be allowed to reach the surface. In addition, there were always some concerns that the fluid level was unknown and kicks could appear quite suddenly and forcefully. PMCD was developed to be able to continuously monitor the pressure at surface. [7] Here an RCD was placed on top of the well and the annulus below was filled with a fluid with a density such that a pressure was needed on top of the well to balance the fractures. This made it possible to monitor pressure changes in the well which for instance could be caused by a migrating kick. PMCD grew out of practical experience with the FMCD technique used in the deeper parts of the Austin Chalk. [90] In year 2000, this technique was explored on platform wells with Tender Assist- and Jack-Up rigs and has since then evolved to be the safest method to be used for controlling carbonate losses. The subsea developments increased and there were still some carbonates that were left unexplored, this gave the idea of utilizing the PMCD set-up on semi-submersible drilling rigs. Installing an RCD on top of the drilling riser could be done relatively easy due to the previous learnings made from underbalanced drilling and surface BOP techniques. [91]

## 4.2 Pressure Control Principles of PMCD

The primary objective of PMCD is to maintain a constant BHP and reach the TD while avoiding uncontrolled events and minimizing drilling complications. The light annular mud should have a weight that leads to a hydrostatic pressure that is slightly below the reservoir pressure. The reason for this is to prevent any mud losses into the loss circulation zone. To prevent fluid from being pushed out of the hole, the annulus is closed with an RCD. A small backpressure, generated by the LAM, will be monitored to record any changes in the reservoir pressure and to make sure that no significant volumes of gas will enter the wellbore. An increasing backpressure is also a sign of a kick that migrates upwards in the annulus. The required backpressure is described by [96]:

$$BP_{req} = RP_{top} - AHP$$

Where:

- $BP_{req}$  = Predetermined backpressure [psi]
- $RP_{top}$  = Reservoir pressure on top of loss zone [psi]
- $AHP$  = Annular hydrostatic pressure [psi]

The hydrostatic pressure, generated from the height of the LAM column, is determined by:

$$AHP = 0.052 * D_{top} * AFD$$

Where:

- $D_{top}$  = Vertical depth of loss circulation zone [ft]
- $AFD$  = Annular fluid density = LAM density [ppg]

The formulas above are in oilfield units because they are extracted from an SPE article originating from Indonesia.

If a kick is taken, the pressure in the annulus will start to increase. When the pressure at top reaches a pre-determined limit, the entire region with LAM and the migrating kick will be bullheaded back into the formation. The operation is finished when the initial surface pressure is reached again. One should note that bringing the kick to surface just below the RCD would possibly threaten the pressure capacity of the RCD. Hence, during the drilling process, there will be periodic repetitions of this bullheading process. It is

therefore important to have sufficient volumes of LAM available. In offshore operations, the SAC fluid used for drilling can e.g. be seawater where there are unlimited volumes available. The wellbore is circulated to LAM density with a weighted pill to maintain primary well control before any tripping is done. [96]

#### 4.2.1 Pressure Control Example

The following example is based on an exam exercise given in [98]. It is included for increasing the understanding of the method.

An imaginary well is drilled through a carbonate formation with seawater as the sacrificial fluid. The fracture is positioned at 3500 m depth and has a pressure of 1.5 s.g. This means that if the wellbore pressure is slightly above 1.5 s.g. the fluids will be forced into the fractures, and if slightly below an influx from the formation will occur. In other words, the pore and fracture pressure are the same and equal to 1.5 s.g.

The LAM fluid should be designed such that with a 10 bar RCD pressure the annular pressure will balance the fracture pressure at 3500 m depth. Hence, the LAM density should be:

$$10 \text{ bar} + \rho_{LAM} * 3500 \text{ m} * 0.0981 = 1.5 \text{ s.g.} * 3500 \text{ m} * 0.0981$$

$$\rho_{LAM} = 1.47 \text{ s.g.}$$

Assuming the bit is at 4000 m and the friction in the annulus is 14 bar, the ECD at the bottom will be:

$$P_{frac} = 1.5 \text{ s.g.} * 3500 \text{ m} * 0.0981 = 515 \text{ bar}$$

$$P_{h_{sw}} = 1.03 \text{ s.g.} * 500 \text{ m} * 0.0981 = 50.5 \text{ bar}$$

$$\begin{aligned} P_{bottom} &= P_{frac} + P_{h_{sw}} + P_{fric} \\ &= 515 \text{ bar} + 50.5 \text{ bar} + 14 \text{ bar} \\ &= 579.5 \text{ bar} \end{aligned}$$

$$ECD = \frac{579.5 \text{ bar}}{4000 \text{ m} * 0.0981} = 1.48 \text{ s.g.}$$

Further assuming that a 12 ¼" well is being drilled through a rock with a density of 2.6 kg/dm<sup>3</sup> with an ROP equal to 31 m/h. The drilled cuttings are transported along with the seawater, which is incompressible, and the flowrate is 1500 lpm. During a 10-minute time period, the following amount of mass, consisting of cuttings and seawater, will be injected into the fractures:

$$12.25 \text{ " } = 12.25 * 2.54 \text{ cm} = 0.31115 \text{ m}$$

$$A_{hole} = \frac{\pi}{4} * 0.31115^2 = 0.076 \text{ m}^2$$

$$ROP = \frac{31 \text{ m/h}}{3600} = 0.00861 \text{ m/s}$$

$$Volume \text{ rate cuttings} = A_{hole} * ROP = 0.076 \text{ m}^2 * 0.00861 \text{ m/s} = 0.000654 \text{ m}^3/\text{s}$$

$$\begin{aligned} Mass \text{ rate cuttings} &= volume \text{ rate cuttings} * density \text{ of cuttings} \\ &= 0.000654 \text{ m}^3/\text{s} * 2600 \text{ kg/m}^3 = 1.7 \text{ kg/s} \end{aligned}$$

$$Volume \text{ rate seawater} = 1500 \text{ lpm} = 0.025 \text{ m}^3/\text{s}$$

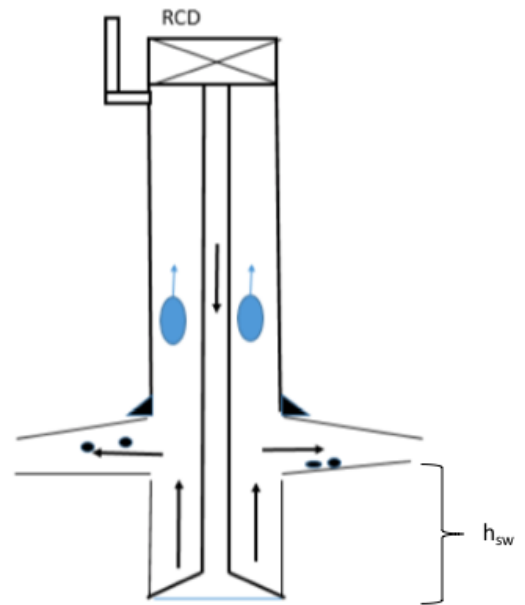

Figure 4. 2 PMCD Pressure Example, Illustration 1 [98]

$$\begin{aligned} \text{Mass rate seawater} &= \text{volume rate seawater} * \text{density of seawater} \\ &= 0.025 \text{ m}^3/\text{s} * 1030 \text{ kg}/\text{m}^3 = 25.75 \text{ kg}/\text{s} \end{aligned}$$

$$\text{Total mass injected into fractures} = (1.7 + 25.75) \text{ kg}/\text{s} * 600 \text{ s} = 16470 \text{ kg}$$

Assuming a kick enters the well and starts to migrate up the well, an increase in the RCD pressure will be seen. A kick migrating in a sealed wellbore will lead to increased pressure since the gas is not allowed to expand as it normally would have done when not fully sealed. When the kick migrates upwards some liquid will be forced downwards and into the fractures. Hence, there will be room for some gas expansion of the kick and the pressure build up will be a bit different compared to a situation where the formation cannot take fluids. A model for this was presented in SPE 185276 [102]. It was also discussed in the master's thesis of Eirik Aas Lind [103]. The pressure at any point in the annulus above the fracture will be equal to the pressure in the fractures minus the hydrostatic pressure of the mixture between the fracture and the point of interest.

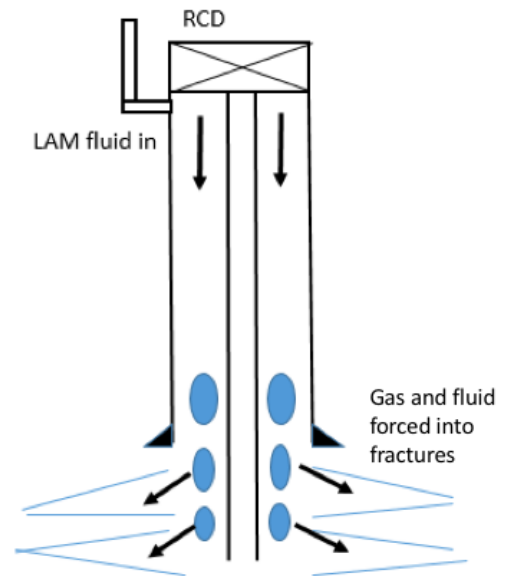

Figure 4. 3 PMCD Pressure Example, Illustration 2 [98]

It is important to stop the kick from migrating up to the RCD, as the increased pressure may exceed the RCD's pressure rating and cause it to fail. In order to prevent the kick from migrating, a bullheading operation is performed by pumping LAM into the annulus and thereby forcing the kick downwards and back into the fractures. It is assumed that the inside diameter of the casing is 12,5", the drillstring outer diameter is 5" and the gas volume fraction is 0.30. The flowrate required to be able to force the kick back into the fractures will then be:

$$\text{Gas slip relation: } v_g = K(v_l \alpha_l + v_g \alpha_l) + S$$

$$\text{Setting } v_g = 0 \text{ gives: } v_l = \frac{-S}{K * \alpha_l} = \frac{-0.5}{1.2 * 0.70} = -0.595 \text{ m}/\text{s}$$

$$12.5" = 0.3175 \text{ m}$$

$$5" = 0.127 \text{ m}$$



$$\text{Area between casing and drillstring} = \frac{\pi}{4} * (0.3175^2 - 0.127^2) = 0.0665 \text{ m}^2$$

$$\text{Bullhead flowrate} = 0.595 \text{ m/s} * 0.0665 \text{ m}^2 = 0.0396 \text{ m}^3/\text{s} * 1000 * 60 = 2376 \text{ l/min}$$

The last calculation shows the importance of using a sufficiently large flowrate to overcome gas migration when bullheading. This has to be considered in all types of bullheading operations as gas will tend to migrate upwards.

### 4.3 Equipment

The CBHP method and PMCD both require a closed system in order to apply backpressure. The RCD is key in creating the closed system and is the main component in both methods. The difference lies in the return flow since the PMCD method does not have any returns to surface. The Downhole Annular Valves and Non-return Valves, mentioned in chapter 2.5, are also utilized when performing PMCD. If the CBHP- and PMCD methods are combined, the MGS must also be in place. The following figure is an illustration of a PMCD set-up, but some standard rig equipment has been excluded for simplicity. [81] [77]

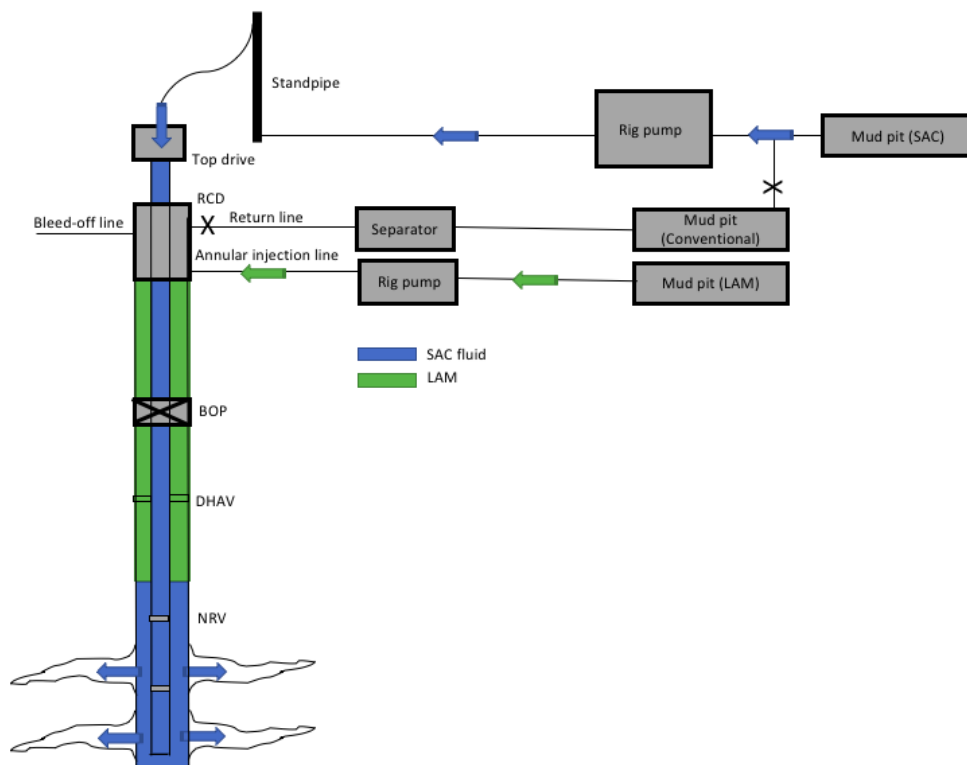

Figure 4. 4 PMCD Equipment Configuration

#### 4.4 Barriers

PMCD has not yet been performed on the NCS and is therefore not included in the Norsok D-010 Standard. The following well barrier figure is an example from a PMCD well in East Malaysia.

Conventional Drilling	Pressurized Mud Cap Drilling	
<b>Primary Well Barrier Elements (WBE)</b>		
Fluid Column	Fluid Column	<i>Underbalanced MW</i>
	Casing Cement	<i>Common WBE</i>
	Casing String	<i>Common WBE</i>
	Wellhead	<i>Common WBE</i>
	BOP's (Body)	<i>Common WBE</i>
	Marine Riser	<i>Subsea BOP</i>
	Rotating Control Device (RCD)	
	PMCD Flowlines & Valves	
	Work String	<i>Above NRV's</i>
	Non Return Valves (NRV)	<i>Minimum two</i>
<b>Secondary Well Barrier Elements (WBE)</b>		
Annular Cement Casing	Annular Cement Casing	<i>Common WBE</i>
Casing String	Casing String	<i>Common WBE</i>
Wellhead (incl Hanger)	Wellhead (incl Hanger)	<i>Common WBE</i>
BOP's	BOP's	<i>Common WBE</i>

Figure 4.5 Well Barrier Elements of a PMCD Operation [97]

#### 4.5 Well Control

During PMCD, pressure in the annulus and in the drillpipe is monitored. If there is an influx into the well, the pressure in the annulus will increase, but not the pressure in the drillpipe. There is a limit for how much the pressure in the annulus is allowed to increase. This depends on several things, such as the surface equipment's pressure ratings, e.g. the RCD. The well annulus is filled with LAM which is hydrostatically underbalanced, and the amount of SBP applied is the difference between the hydrostatic pressure caused by the LAM and the formation pore pressure. If there is a hydrocarbon influx into the well, the annular hydrostatic pressure caused by the LAM would decrease as the lighter hydrocarbons would replace the LAM in the annulus. By reducing the hydrostatic pressure, the SBP would have to increase in order to keep the well at balance. [67]

If this pressure limit is reached, the procedure is to start pumping LAM into the annulus in order to force the influx back into the formation. This must be done at a higher rate than the gas migration rate and is

often done in several cycles. The volume of the LAM to be bullheaded in during a cycle depends on the gas migration rate, the required bullheading rate and the desired safety factor. If the gas migration rate is high, the SBP will increase fast and the time before the pressure limits are reached is shorter, meaning that the bullheading procedure must be actuated at an earlier time, thus increasing the cycle frequency. [67]

The following figure shows how the SBP increases when an influx migrates up the annulus. When the SBP reaches the predefined maximum pressure limit, bullheading starts and LAM is pumped down the annulus, forcing the influx back into the formation. The SBP then decreases until it resumes the stable value it had prior to the kick. Bullheading is then stopped and the cycle is repeated when necessary. This figure is based on simulations and it is important to keep in mind that it not necessarily represents reality. [67]

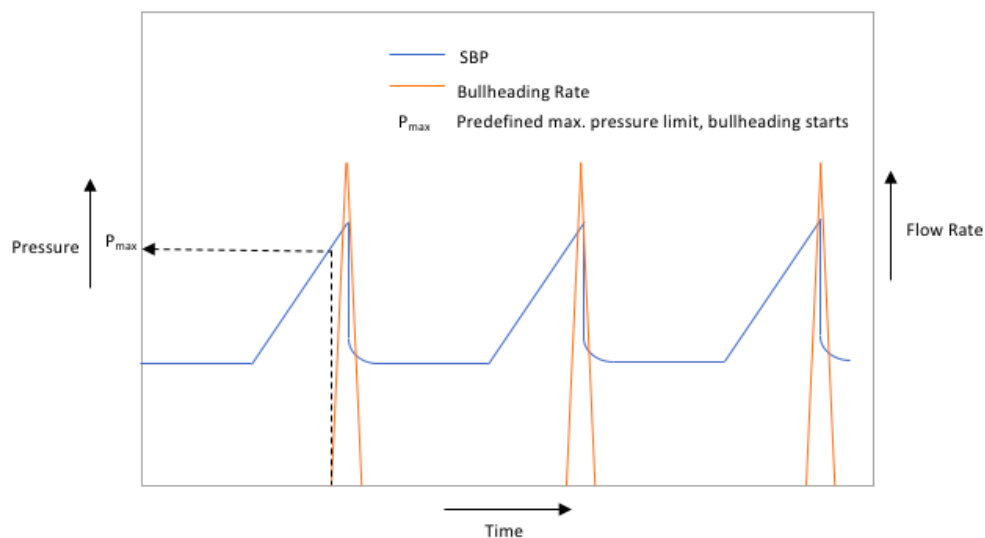

Figure 4. 6 Depiction of Bullheading Influxes, Inspired by [77]

## 4.6 Case History

### 4.6.1 Offshore Sarawak, Malaysia

Shell Malaysia has since the 1970's drilled more than 150 wells into the carbonate structures offshore Sarawak. Historically, one out of six wells in this area experience total losses. The losses are mainly caused by karsts. These losses were controlled by placing Diesel Oil Bentonite (DOB) plugs. Later these plugs were replaced by more sophisticated fiber cement plugs. However, these plugs lead to a risk of

even worse well control situations; the drill string could get plugged and stuck. After the PMCD technology was developed in year 2000, no significant losses have been recorded in over 20 carbonate wells offshore Sarawak. [91]

#### 4.6.2 Onshore South Sumatra, Indonesia

The wells in the Soka field onshore South Sumatra are drilled through the Baturaja formation, which is a fractured carbonate reservoir where severe losses and kicks are common while drilling. Due to total losses and gas kicks, drilling the Soka 2006-1 well was temporarily abandoned for two years. After the total loss of circulation occurred, almost two months were spent to try to control and drill this well, but without any results. In July 2006, the well was plugged and abandoned. Then, it was planned to be re-entered when the right approach to be able to overcome the drilling issues was developed. PMCD was the chosen method to finish the operations in Soka 2006-1. [92]

PMCD have two basic criteria to be met before applying it. It requires a highly conductive formation exposure and a large fluid supply. Soka 2006-1 had a highly conductive formation exposure, which means that the reservoir formation was largely fractured, enough to accept the amount of fluids and cuttings that were pumped into it. A river, two kilometers away from the rig site, was used for fluid supply. The PMCD system was set up in stages. The RCD, valves and pipework needed were installed before the 6" hole section, but the PMCD system was not used until fractures or mud losses were encountered. A 6" bit was run to penetrate the two plugs from when the well was temporarily abandoned. Total circulation losses were experienced when the last plug was penetrated. From this, gas migration up the annulus followed and it was decided to switch to PMCD mode. High viscosity pills were pumped after every connection and after reaching TD, a LCM pill was pumped to try to plug the zone that was causing circulation losses. The reason for pumping this LCM pill was that they thought the fractures were already filled up with cuttings from drilling. However, there were no indications that the pill had any effect, so a DOB plug was injected as an attempt to seal off losses and prevent gas kicks. This was done three times and at the third attempt, the casing was successfully isolated from the gas, preventing the gas from migrating up to the surface. Circulation was normal when running the liner. However, total losses were again experienced when reaching a depth of 1015 meters and it was decided to use the PMCD mode while running the liner. Despite problems with the annular packers, the liner was successfully installed and cemented in PMCD mode. There was no NPT associated with PMCD. There was sufficient hole cleaning and good ROP during drilling of the re-entry operation. This operation was made in only 19

hours with PMCD technology, compared to the one and a half months in the previous attempt to control and drill the well with conventional methods, which ended up in temporary abandonment for two years. [92]

#### 4.6.3 Offshore Santos, Brazil

While drilling a well in the Santos Basin, major losses occurred when using conventional drilling methods. This well was the first well in this part of the Lula's field in Santos Basin and was designed to be a production well but was unable to reach all objectives. The well was successfully re-entered and reached target reservoir when combining the CBHP and PMCD technologies. This was the first time PMCD had been used on a DP (Dynamic Positioning) rig in an offshore well in Santos Basin. [93]

Operations started on the 15<sup>th</sup> of August in 2012 with West Taurus rig. The project was drilled without problems until the top of the reservoir was reached. The reservoir phase started with a Formation Integrity Test (FIT) and was followed by coring operations. 84 meters were cored without problems, but then a 210 bph (33.39 m<sup>3</sup>/h) fluid loss occurred. 3850 bbls (612.1 m<sup>3</sup>) of cement were injected to try to control the loss of fluid, 30 000 bbls (4769.62 m<sup>3</sup>) of mud were lost to the formation in 22 days and only 29 meters of formation were drilled in 12 hours during these 22 days. It was decided to run the production casing before reaching TD to secure and test the already drilled production zone. A cement plug was used to isolate the last 26 meters and the production casing was cemented without any problems. A production test was completed to evaluate this first zone and the well was temporarily abandoned with two cement plugs; one in front of the perforations and a surface plug. [93]

The opportunity to re-enter the well and evaluate deeper zones arose when installation of MPD system on the rig was done and when finishing the first CBHP drilling operation. The type of fluid to be used in drilling and completion operations was chosen to be synthetic oil base fluid. After the fluid was selected, the completion program and drilling and completion sequences were defined to achieve the following objectives: [93]

1. *“Drill the cement plugs, in CBHP mode;*
2. *Reperforate the upper production zone, that was already perforated and tested, in CBHP mode;*
3. *Drill in CBHP/PMCD mode until 30 m above the oil/water interface;*
4. *Run in lower completion consisting of a slotted liner + Packer Seal Bore + TDP (Tubing Disappearing Plug), in CBHP or PMCD mode.”* [93]

The perforation in MPD (CBHP) mode was a pioneer operation in Petrobras and one of the first in the world. It was chosen to be in CBHP mode to avoid changing the fluid several times during the operations. The LAM for the PMCD operations was proposed so that it was not required to change the mud weight after the CBHP operation. The SAC chosen for the PMCD mode was water with additives. A loss control management flow diagram and change from CBHP mode to PMCD mode was made. [93]

Perforating in CBHP mode was successful, although there was an observed damage in the NRVs that could cause a problem while POOH (Pulling Out of Hole) after the perforations. It was proved that drilling in CBHP mode was very effective in minimizing fluid losses. The fluid loss was decreased to be 520 bbls (82.67 m<sup>3</sup>) in 27 hours, during drilling of 89 meters. In PMCD mode, 70 meters were drilled with 12 500 bbls (1987.34 m<sup>3</sup>) of SAC and 180 bbls (28.62 m<sup>3</sup>) of LAM were injected into the loss zone. It was proved that bullheading cycles of LAM was successfully preventing any reservoir fluid migration to surface. In the first circulation after the lower completion was set, however, a small amount of influx in front of the perforated zone was detected. All in all, the operations were concluded successfully. [93]

## 4.7 Challenges and Benefits

### 4.7.1 Handling fractured formations

The main benefit with PMCD is the ability to drill with total losses. [78] This is, as mentioned previously, the only way to drill certain formations, such as highly fractured, vugulated and cavernous carbonates. With 60 % of the world's oil and 40 % of the world's gas reserves being held in carbonates, it is obvious that this method has a high range of applications and can unlock reserves that otherwise would have been impossible to exploit. [79] These formations form a dilemma as it is the formations fractures which make them highly productive, but at the same time, the fractures make it very difficult, or even impossible, to drill through the formation.[80] The following is a picture of karst formations taken in Billefjorden on Svalbard. This is the same carbonate structure exists in the Barents Sea.



*Figure 4. 7 Karst formation on Svalbard [99]*

PMCD was developed so that drilling can proceed while losing all drilling fluids to the formation and enables drilling to TD in such areas. The application of PMCD is however only possible if the specific formation is able to accept the drilling fluid and cuttings. In order to determine the formation's capability of accepting fluids, an injectivity test is performed. This is done by injecting fluids into both the drillstring and the annulus in increments until the desired drilling rate is achieved. The annular- and standpipe pressure is monitored throughout the test and if they are too high it means that the formation is not accepting the fluid. The density of the sacrificial fluid can then be increased to see if it solves the problem. If the formation still does not accept the fluid, conventional drilling must be resumed. The maximum allowable pressure monitored in the annulus or in the standpipe is limited by the equipment's maximum pressure rating. [81]

#### 4.7.2 Cost

Using PMCD is also, in many ways, beneficial with regards to costs. Firstly, using PMCD reduces NPT significantly by being able to continue drilling while "suffering" from losses. Sacrificial fluid is also much cheaper than LCM and cement squeeze operations. PMCD is also in many cases preferred over adding LCM because the risk of formation damage is reduced, which is very important with regards to the productivity of the reservoir, and thereby also its profitability. [8282]

### 4.7.3 Safety

Using PMCD instead of conventional drilling is safer when suffering from losses since loss of circulation during conventional drilling may lead to complex well control situations. This because a kick may be taken, and when the mud column is not controlled or known it is difficult to perform the kill operation as the mud column is what one is trying to recover. Another safety benefit arising from PMCD is the ability to drill through formations with hazardous gases present, e.g. H<sub>2</sub>S and CO<sub>2</sub>, while preventing them from reaching the surface since all returns are forced into the formation. Though drilling with no returns is a lot safer under such conditions, the geologists are not particularly fond of the lack of cuttings samples which make their job of evaluating the subsurface difficult. [78]

### 4.7.4 Fluids and Logistics

An aspect of PMCD that is more of a challenge, is the logistics connected to the massive amounts of different drilling fluids. With PMCD 19-24 000 m<sup>3</sup> of fluid may be needed for a single week of drilling, [78]. Offshore PMCD has easy access to seawater if that were to be used as the sacrificial fluid but has limited space for storing the more complex LAM. Onshore facilities, however encounter the opposite situation. The fluid program for PMCD can be very complex and has many requirements. For instance, the fluid must be non-damaging to the formation, it must be inexpensive and easy to weight up on the rig site and it must be mixable in high volumes. [8383]



## Chapter 5 – Discussion

This chapter will include a discussion of the different MPD methods described in the previous chapters.

The challenges each of these methods address will be mentioned and connected to the case studies from chapter 2-4, where it has been proven successful.

### 5.1 Applications

The following table is meant to give an overview of application areas for the different MPD methods.

<b>Applications</b>	<b>CBHP</b>	<b>CML</b>	<b>PMCD</b>
Depleted fields	X	X	
Ultra-deep water		X	
HPHT wells	X	X	
ERD wells	X	X	
Highly deviated wells	X	X	
Highly fractured formations/ karst		X	X
In use on NCS	X	X	

#### 5.1.1 Constant Bottom Hole Pressure

CBHP has a wide range of applications, such as drilling in depleted fields suffering from narrow pressure windows, HPHT fields, unstable formations and highly deviated wells in need of enhanced hole cleaning. The benefit of improved hole cleaning applies specifically to the continuous circulation variation of the CBHP method.

The main benefit of this system is that one is able to maintain a precise constant pressure that is the same both during connections and drilling/circulation. This makes it especially useful for handling tight pressure margins effectively.

Using the CBHP method (E-NBD™) on a HPHT field in the Lower Mediterranean Sea proved to be very beneficial considering both kick events and NPT. The influx size was reduced with 35 m<sup>3</sup> compared with conventional drilling, and NPT was reduced with 14 days. HPHT fields are especially prone to wellbore breathing, and the Mandarin East field on the NCS is an example of such a case. This phenomenon may cause the need for extra circulation time due to the influx of formation fluid into the wellbore. However,

keeping the pressure constant reduces this effect and thereby decreases NPT. An estimated 10 days and 7.5 MM\$ were saved by applying the CBHP method to this field.

In unstable formations, such as coal, removing pressure fluctuations due to pumps on and off can prevent the wellbore from collapsing and thereby decrease the risk of mechanical sticking.

Providing continuous circulation in long, highly deviated wells greatly improves hole cleaning as the cuttings are kept moving and are not allowed to settle in the well when the pumps are not running.

When applying conventional drilling in ERD wells, the friction will become large and the difference between the ECD and the static mud weight may become larger than the drilling margin. The CBHP aids in solving this problem by being able to maintain the same pressure both during dynamic and static conditions.

#### 5.1.2 Controlled Mud Level

The CML method also has a wide range of applications, but is especially beneficial in deepwater operations, in long wells and in HPHT wells.

The CML method was successfully applied to a well located at 2260 meters water depth. The ECD effects in this well were eliminated, the reservoir section was drilled with no losses to the formation and hole cleaning was sufficient with no indication of fill or drag.

This is a system which makes it possible to manage wells where the ECD is a problem and wells where there is a risk of exceeding the fracture pressure and thereby inducing losses. These challenges may occur in wells where the pressure is severely depleted or for instance in ERD wells where the friction is large. The solution is then to reduce the mud level in the riser to induce a lower effective mud weight in the system. This way it is possible to lower the hydrostatic pressure while maintaining the required circulation needed to achieve important functions, such as cuttings transport. It is possible to keep the pressure constant both during dynamic and static conditions by adjusting the mud level. This is, for instance, very beneficial in HPHT wells which have very narrow pressure margins. The system is very effective in loss scenarios as it is possible to reduce the mud level without reducing the flow rate and threatening the cuttings transport. This is much more effective than circulating a new mud through the system. The Controlled Mud Cap Drilling method has been developed from the CML method to be able to handle severe loss situations.

It is also beneficial for ultradeep water application since it has an inherent dual gradient effect that makes the well pressure fit better in between the pore- and fracture gradients typically seen for deepwater drilling prospects. This makes the system able to drill deeper without setting casing, compared to a conventional system.

The EC-Drill™ method was successfully applied in a few other deepwater wells in the Caribbean. Using and further developing the system increased ROP and no drilling issues or losses were experienced.

The CML method was used to drill on the severely depleted Troll field on the NCS. The depletion made it impossible to drill conventionally as the mud weight could not be lowered enough to avoid losses. It was proven that this method gives very accurate loss detection.

### 5.1.3 Pressurized Mud Cap Drilling

PMCD has a more restricted area of application compared to the other two methods. The method was developed to handle severe losses in karst type carbonate formations. There are certain requirements that need to be met in order to implement this technology; severe or total losses, a formation capable of accepting the sacrificial fluid and access to sufficient amounts of sacrificial fluid. Hence, it is important to ensure that the formation has sufficient injectivity.

The PMCD method was successfully applied onshore South Sumatra, Indonesia. While applying PMCD, no NPT was experienced. Drilling with sacrificial fluid enabled a good ROP and made it possible to complete the operation in only 19 days. The same operation was tried with conventional drilling, but the operation took one and a half months and was not successful.

The success of combining CBHP and PMCD was proven when drilling a well offshore Brazil, in the Santos Basin. This combination is especially beneficial with regards to the mud program, as the underbalanced CBHP fluid can be used as light annular mud in PMCD operations. Drilling with the inexpensive SAC fluid made it possible to drill with losses, resulting in approximately 1990 m<sup>3</sup> of SAC fluid lost to the formation.

## 5.2 Systematic Overview of Challenges and Benefits

The following tables are meant to give an overview of the challenges and benefits for the different MPD methods.

<b>Challenges</b>	<b>CBHP</b>	<b>CML</b>	<b>PMCD</b>
Sensitive to influxes/alarms	X	X	
U-tubing		X	
Fluid logistics			X
Costly	X	X	X
Time (Planning and training)	X	X	X
Large rig footprint	X	X	X
Integration of systems with existing rig-ups	X	X	X

<b>Benefits</b>	<b>CBHP</b>	<b>CML</b>	<b>PMCD</b>
Handle small pressure margins	X	X	
Handle large ECDs		X	
Highly accurate pressure control/automation	X	X	
Early kick/loss detection	X	X	
Increased safety	X	X	X
Drill longer sections/Reduced casings	X	X	
NPT reduced	X	X	X
Expand exploration area	X	X	X
Saves money (reduced NPT, casings...)	X	X	X
Small kicks handled without NPT	X		
Handles severe losses		X	X
Handle unstable formations	X		
Qualified towards NORSOK D-010	X	X	
Applicable on- and offshore	X		X

The main goal with the CBHP- and CML methods is to manage the pressure to be able to navigate through narrow pressure windows. Using automation to precisely control the pressure makes it possible to react to pressure variations very fast and makes it possible to keep the pressure close to constant. This is very beneficial when drilling through unstable formations, such as coal, since pressure fluctuations may damage the formation. This advantage is however more pronounced in the CBHP method than the CML method because adjusting the pressure through choke regulation takes less time than by adjusting the mud level. The CML method however, can handle large ECDs in situations where the friction is so high that it is not possible to sufficiently decrease the mud weight. This can be done without compromising cuttings transport requirements. It also has a general benefit in handling loss situations. The mud level can be reduced fast, avoiding the losses without having to circulate a new lighter fluid into the system. For both systems the improved downhole pressure control will reduce the number of collapses, kick and loss situations that again will lead to reduced NPT.

Early kick/loss detection is one of the major benefits for the CBHP and CML methods, as it greatly increases the safety of the systems. However, with the increased complexity and accuracy that comes with the MPD systems, the sensitivity of the systems also increases, which may cause excessive alarms to go off, and unnecessary NPT can occur. The CBHP method, specifically the SBP method, also has the advantage of being able to circulate out small kicks without any NPT.

Implementing MPD systems on rigs is a very costly process in many ways. In addition to expensive equipment, it takes a lot of time to plan the operation and training the rig crew. However, the extra time and cost put into MPD operations is usually worth it as this technology is an enabler and has many benefits. Some of the most important ones are the considerable reduction in NPT, the possibility of drilling longer hole sections, which reduces the costs related to the casing operation and it makes it possible to drill in new and difficult exploration areas, which were not accessible with conventional drilling.

Integrating the MPD systems with the existing rig structure may be a difficult process. There is a lot of additional equipment needed for performing MPD which can be an issue on offshore rigs with limited deck space. PMCD needs even more space to store the enormous amounts of drilling fluids.

The PMCD and CML methods have both proved to be able to handle severe losses while drilling. PMCD is the most used method to perform such operations, but recently the CML technology has been utilized for the same purpose. The method is then called CMCD.

The CBHP method is the only MPD method that is specifically mentioned in the NORSOK D-010 Standard. However, since CML drilling has been performed on the NCS, it must also be in accordance with the applicable rules and regulations stated there. PMCD is not included, as this type of drilling has not yet been performed on the NCS, and it may never be necessary.

CBHP has a long track record and was originally developed for onshore operations before it was taken into use on fixed installations and floaters, offshore. Since PMCD and CBHP drilling, to a large extent, use the same equipment, they can both be applied on-and offshore. CML is only applicable for offshore wells and is a method under continuous development.

## Conclusion

The objective of this thesis was to gather information about different MPD methods and discuss when they are beneficially used. The first method described was the CBHP method, where the aim is to keep the bottomhole pressure constant both during dynamic- and static conditions. This is done by providing continuous circulation or by applying backpressure via regulation of the choke. Maintaining constant pressure will reduce formation instability problems and enable drilling through tight pressure margins.

The next method described was the CML method. The goal with this method is to keep the bottom hole pressure constant by adjusting the mud level in the riser. It can handle wells where there is a risk of fracturing the formation and creating losses due to either depleted formation pressure or pressure margin problems. For some depleted fields, it is not possible to find a mud weight that is low enough to utilize conventional drilling as the mud weight cannot be lower than approximately 1 s.g.

The CML method can easily cancel out the ECD effect by reducing the mud level in the riser while maintaining the needed circulation to satisfy cuttings transport. Any losses can be cured fast by reducing the mud level even further without using excessive time on changing the mud weight. Both the CBHP method and the CML method can detect kick and loss situations rapidly. The CBHP method, which is based on using an RCD in combination with a choke and separator equipment, can handle small kicks without having to close the BOP.

The final method described was the PMCD method, which stands out compared to the other two. The goal with this method is to enable drilling through cavernous formations by injecting sacrificial fluid into the fractured formation, so that the formation gets saturated with the low-cost SAC fluid and drilling can proceed without losses using conventional mud. The premise for using this method is that the formation has sufficient injectivity. The application of backpressure at surface gives a high effective mud weight so that the density of the mud can be reduced. Achieving this high mud weight by adding weighting materials to the drilling fluid may cause hole cleaning problems as these particles may precipitate and accumulate in the bottom of the well.

The pressure in the CBHP- and CML methods can be controlled precisely because the processes are partly automated. This is done by measuring different values, e.g. pressure and flow, comparing the values to the set-point and adjusting accordingly. This process is based on application of control engineering algorithms. Automating such processes has improved the safety aspect of the operations, as well as the accuracy of the pressure control.

Other benefits include the ability to drill unstable formations and HPHT, deepwater and depleted fields. Using MPD to drill these types of fields has the common benefit of improved well control with respect to kick and loss detection. Increased detection may however cause excessive alarms. Unawareness in such situations may lead to confusion and unnecessary NPT. It is therefore crucial to ensure proper training of the crews, communication between the different parties involved and integration of the MPD systems with the existing rig set-up.

The CBHP method has a longer track record compared with the CML method and can often be combined with PMCD. Until now, only the CBHP and CML methods have been used on the NCS. It may never be necessary to apply PMCD on the NCS as the CMCD variation of the CML method addresses the same issues related to severe losses, and may be sufficient for the conditions present in parts of the Barents Sea.

It can be concluded that MPD is worth the time and cost it takes to be implemented as long as the specific situation demands it. In such situations the pros that follow far outweigh the cons, and as fields are reaching maturity and the easily accessible fields have been exploited, MPD will certainly be a technology worth focusing on in the future.



## Table of References

1. SPE International, PetroWiki, PEH: Drilling Problems and Solutions, [http://petrowiki.org/PEH:Drilling\\_Problems\\_and\\_Solutions](http://petrowiki.org/PEH:Drilling_Problems_and_Solutions) <02.06.18>
2. Kenneth P. Malloy, 2008, A Probabilistic Approach to Risk Assessment of Managed Pressure Drilling in Offshore Applications, <https://www.bsee.gov/sites/bsee.gov/files/tap-technical-assessment-program/582ac.pdf> <02.10.18>
3. Kenneth P. Malloy et al., 2009, Managed Pressure Drilling: What It Is and What It Is Not, IADC/SPE 122281, presented at the IADC/SPE Managed Pressure Drilling and Underbalanced Operations Conference and Exhibition held in San Antonio, Texas, 12-13 February
4. John-Morten Godhavn and Kjetil Arne Knudsen, 2010, High Performance and Reliability for MPD Control System Ensured by Extensive Testing, IADC/SPE 128222, presented at the 2010 IADC/SPE Drilling Conference and Exhibition held in New Orleans, Louisiana, 2-4 February
5. IADC, 2011, Managed Pressure Drilling (MPD), <http://www.iadclexicon.org/managed-pressure-drilling-mpd/> <02.12.18>
6. Ben Gedge et al., 2013, Managed Pressure Drilling – A Solution for Drilling the Challenging and Un-drillable Wells in Vietnam and South East Asia, SPE 165775, presented at the SPE Asia Pacific Oil & Gas Conference and Exhibition held in Jakarta, Indonesia, 22-24 October
7. Bill Rehm et al., Managed Pressure Drilling, 2008, Gulf Publishing Company, Houston, Texas, ISBN: 978-1-933762-13-5
8. Schlumberger, Oilfield Glossary: keyseat, <http://www.glossary.oilfield.slb.com/Terms/k/keyseat.aspx> <02.08.18>
9. H. Santos et al., 2006, Deepwater Drilling Made More Efficient and Cost-Effective: Using the Microflux Control Method and an Ultralow-Invasion Fluid to Open the Mud-Weight Window, OTC 17818, presented at the 2006 Offshore Technology Conference held in Houston, Texas, 1-4 May
10. SPE International, PetroWiki, Kicks, <http://petrowiki.org/Kicks> <02.14.18>
11. Steve Nas, 2010, Deepwater Managed Pressure Drilling Applications, SPE 132049, presented at the CPS/SPE International Oil & Gas Conference and Exhibition held in Beijing, China, 8-10 June
12. Standards Norway, Well Integrity in Drilling and Well Operations, NORSOK Standard D-010, Rev. 4, June 2013
13. YokogawaUK, 2011, Coriolis Flow Meter (Principle of Operation), <https://www.youtube.com/watch?v=PvXgaDoZr1E> <02.15.18>

14. Halliburton, 2016, Rig Pump Diverter, [http://www.halliburton.com/public/ts/contents/Data\\_Sheets/web/H/H08488.pdf](http://www.halliburton.com/public/ts/contents/Data_Sheets/web/H/H08488.pdf) <02.07.18>
15. Schlumberger, Oilfield Glossary; ECD, <http://www.glossary.oilfield.slb.com/Terms/e/ecd.aspx> <02.21.18>
16. Halliburton, Rotating Control Devices, [http://www.halliburton.com/en-US/ps/testing-subsea/optimized-pressure-drilling/rotating-control-devices/default.page?node-id=hfvq7iru&nav=en-US\\_sperry\\_public](http://www.halliburton.com/en-US/ps/testing-subsea/optimized-pressure-drilling/rotating-control-devices/default.page?node-id=hfvq7iru&nav=en-US_sperry_public) <02.22.18>
17. Weatherford, Secure Drilling Services: SeaShield Rotating Control Devices, [https://www.weatherford.com/en/documents/brochure/products-and-services/drilling/rotating-control-devices-subsea-rotating-control-devices-\(marine-series\)/](https://www.weatherford.com/en/documents/brochure/products-and-services/drilling/rotating-control-devices-subsea-rotating-control-devices-(marine-series)/) <02.22.18>
18. Buyon Guo et al., Petroleum Production Engineering – A Computer Assisted Approach, 2007, Gulf Professional Publishing, Elsevier Inc., Oxford, UK, ISBN: 978-0-7506-8720-1
19. Halliburton, Customer Guide to Managed Pressure Drilling, <http://www.halliburton.com/public/ts/contents/Brochures/web/GBA-CustomerGuide.pdf> <02.22.18>
20. Halliburton, Optimized Pressure Drilling – Managed Pressure Drilling, GeoBalance Services, Coriolis Flow Meter, [http://www.halliburton.com/public/ts/contents/Data\\_Sheets/web/H/coriolis-flow-meter.pdf](http://www.halliburton.com/public/ts/contents/Data_Sheets/web/H/coriolis-flow-meter.pdf) <02.22.18>
21. A. Farahat et al., 2017, A Successful Application of MPD With CBHP Technique in Temsah Field – A Case History, OMC-2017-534, presented at the 13<sup>th</sup> Offshore Mediterranean Conference and Exhibition in Ravenna, Italy, March 29-31
22. Jon Åge Stakvik et al., 2017, Model-Based Control in Managed Pressure Drilling, SPE/IADC 184649 MS, presented at the SPE/IADC Drilling Conference and Exhibition held in The Hague, The Netherlands, March 14-16
23. IADC, 2017, Drilling Lexicon: Surface Back-Pressure, <http://www.iadclexicon.org/surface-back-pressure/> <03.16.18>
24. Kenneth P. Malloy et al., 2008, A Probabilistic Approach to Risk Assessment of Managed Pressure Drilling in Offshore Drilling Applications, <https://www.bsee.gov/sites/bsee.gov/files/tap-technical-assessment-program/582ac.pdf> <03.16.18>

25. Saad Saeed et al., 2012, Automated Drilling Systems for MPD – The Reality, IADC/SPE 151416, prepared for presentation at the 2012 IADC/SPE Drilling Conference and Exhibition held in San Diego, California, March 6-8
26. Abdallah Farahat, CONSTANT BOTTOM HOLE PRESSURE DRILLING: TECHNIQUES, TOOLS and APPLICATIONS (presentation),  
[http://www.academia.edu/32448499/CONSTANT\\_BOTTOM\\_HOLE\\_PRESSURE\\_DRILLING\\_TECHNIQUES\\_TOOLS\\_and\\_APPLICATIONS\\_presentation](http://www.academia.edu/32448499/CONSTANT_BOTTOM_HOLE_PRESSURE_DRILLING_TECHNIQUES_TOOLS_and_APPLICATIONS_presentation) <03.16.18>
27. IADC, 2017, Drilling Lexicon: Continuous Circulation Method,  
<http://www.iadclexicon.org/continuous-circulation-method/> <03.16.18>
28. A. Calderoni et al., 2011, Managing Pressure Drilling with Continuous Circulation, A Summary of Eni Experience, SPE 147147 , prepared for presentation at the SPE Annual Technical Conference and Exhibition held in Denver, Colorado, October 30 – November 2
29. Weatherford, Continuous Flow System, <https://www.weatherford.com/en/products-and-services/drilling/closed-loop-drilling/continuous-flow-system/> <03.16.18>
30. A. Torsvoll et al., 2006, Continuous Circulation During Drilling Utilizing a Drillstring Integrated Valve – The Continuous Circulation Valve, IADC/SPE 98947, prepared for presentation at the IADC/SPE Drilling Conference held in Miami, Florida, 21-23 February
31. J. W. Jenner, 2004, The Continuous Circulation System: An Advance in Constant Pressure Drilling, SPE 90702, prepared for presentation at the SPE Annual Technical Conference and Exhibition held in Houston, Texas, 26-29 September
32. Svein Syltøy et al., 2008, Highly Advanced Multitechnical MPD Concept Extends Achievable HPHT Targets in the North Sea, SPE/IADC 114484, prepared for presentation at the 2008 SPE/IADC Managed Pressure Drilling and Underbalanced Operations Conference and Exhibition held in Abu Dhabi, UAE, 28-29 January
33. S.K. Naesheim et al., 2011, How MPD with Advanced Flow Detection System was Successfully Applied on an eHPHT Well in the Norwegian North Sea, OTC 21682, prepared for presentation at the Offshore Technology Conference held in Houston, Texas, 2-5 May
34. John-Morten Godhavn, 2010, High Performance and Reliability for MPD Control System Ensured by Extensive Testing, IADC/SPE 128222, prepared for presentation at the 2010 IADC/SPE Drilling Conference and Exhibition held in New Orleans, Louisiana, 2-4 February
35. Angelo Calderoni et al., 2009, Microflux Control and E-CD Continuous Circulation Valves Allow Operator to Reach HPHT Reservoirs for the First Time, IADC/SPE 122270, prepared for

- presentation at the IADC/SPE Managed Pressure Drilling an Underbalanced Operations Conference and Exhibition held in San Antonio, Texas, 12-13 February
36. DrillingFormulas.com, 2011, Well ballooning (wellbore breathing or micro fracture), <http://www.drillingformulas.com/well-ballooning-wellbore-breathing-or-micro-fracture/> <03.16.18>
  37. Brandon Hilts, 2013, Manged Pressure Drilling, SPE 167621 STU, prepared for presentation at the SPE International Student Paper Contest at the SPE Annual Technical Conference and Exhibition held in New Orleans, Louisiana, 30 September – 2 October
  38. André Alonso Fernandes, 2017, Overview of Different Applications for MPD and MCD Techniques on Deepwater Wells, SPE/IADC 1185279, prepared for presentation at the 2017 IADC/SPE Managed Pressure Drilling & Underbalanced Operations Conference and Exhibition held in Rio de Janeiro, Brazil, 28-29 March
  39. Arne Handal, 2013, Safety Barrier Analysis and Hazard Identification of Blowout Using Managed Pressure Drilling Compared with Conventional Drilling, IADC/SPE 164564, prepared for presentation at the IADC/SPE Managed Pressure Drilling and Underbalanced Operations Conference and Exhibition held in San Antonio, Texas, 17-18 April
  40. William Bacon, 2016, MPD Dynamic Influx Control Mitigates Conventional Well Control Pitfalls, SPE/IADC 179185, prepared for presentation at the SPE/IADC Managed Pressure Drilling and Underbalanced Operations Conference and Exhibition held in Galveston, Texas, 12-13 April
  41. Neil Forrest et al., 2001, Subsea for Deep Water Drilling Using Dual Gradient Mud System, SPE/IADC 67707, Prepared for presentation at the SPE/IADC Drilling Conference held Amsterdam, The Netherlands, 27 February-1 March
  42. J.P Schumacher et al., 2001, Subsea Mudlift Drilling; Planning and Preparation for the First Subsea Field Test of a Full-Scale Dual Gradient Drilling System at Green Canyon 136, Gulf of Mexico, SPE 71358, Prepared for presentation at the 2001 SPE Annual Technical Conference and Exhibition held in New Orleans, Louisiana, 30 September-3 October
  43. John H. Cohen et al., 2015, Field Trial of Well Control Solutions with a Dual Gradient Drilling System, SPE/IADC 173822-MS, prepared for presentation at the SPE/IADC Managed Pressure Drilling and Underbalanced Operations Conference and Exhibition held in Dubai, UAE, 13-14 April

44. Robert Ziegler et al., 2013, First Successful Commercial Application of Dual Gradient Drilling in Ultra-Deepwater GOM, SPE 166272, Prepared for presentation at the SPE Annual Technical Conference and Exhibition held in New Orleans, Louisiana, USA, 30 September-2 October
45. Børre Fossli & Roger Stave, 2014, Drilling Depleted Reservoirs using Controlled Mud Level technology in Mature Subsea Fields, SPE 169178-MS, Prepared for presentation at the SPE Bergen One Day Seminar held in Grieghallen, Bergen, Norway, 2 April
46. Robert Ziegler et al., 2013, Successful Application of Deepwater Dual Gradient Drilling, IADC/SPE 164561, Prepared for presentation at the IADC/SPE Managed Pressure Drilling and Underbalanced Operations Conference and Exhibition held in San Antonio, Texas, USA, 17-18 April
47. M. Mir Rajabi et al., 2012, First Application of EC-Drill in Ultra-Deepwater-Proven Subsea Managed Pressure Drilling Method, SPE 151100, Prepared for presentation at the SPE Deepwater Drilling and Completions Conference held in Galveston, Texas, USA, 20-21 June.
48. JPT, EC-Drill Eliminates Effect of Equivalent Circulating Density, Young Technology Showcase Showcase, August 2013, page 38-40
49. J.J Schubert, 2006, Well-Control Procedures for Dual Gradient Drilling as Compared to Conventional Riser Drilling, SPE 99029, Texas A&M U, 24 June.
50. Chris French, 2016, EC-Drill Controlled Mud Level MPD The Key to Higher Efficiency & Reduced Well Costs, Enhanced Drilling, 16 November
51. Tim Tønnessen et al., March/April 2006, "Underbalanced equipment meets challenges in MPD applications offshore Norway", Drilling Contractor, <http://www.iadc.org/dcpi/dc-marapr06/Mar06-tonnessen.pdf> <04.04.18>
52. E.F. Nogueira et al., 2006, "Field Trials of a Managed-Pressure Drilling System Demonstrate the Actual State of the Technology", OTC 18038, prepared for presentation at the 2006 Offshore Technology Conference held in Houston, Texas, 1-4 May 2006
53. Don M. Hannegan et al., 2006-2007, SPE Distinguished Lecturer Series, Managed Pressure Drilling, A "new" way of looking at drilling hydraulics. Overcoming conventional drilling challenges, SPE 112803-DL
54. D. Reitsma et al., 2005, "Utilizing an Automated Annular Pressure Control System for Managed Pressure Drilling in Mature Offshore Oilfields", SPE 96646, prepared for presentation at the Offshore Europe 2005 held in Aberdeen, Scotland, U.K., 6-9 September 2005

55. S.A. Solvang et al., 2008, «Managed Pressure Drilling Resolves Pressure Depletion Related Problems in the Development of the HPHT Kristin Field”, SPE/IADC 113672, prepared for presentation at the 2008 SPE/IADC Managed Pressure Drilling and Underbalanced Operations Conference and Exhibition held in Abu Dhabi, UAE, 28-29 January 2008
56. D. Gomes et al., 2018, “A Numerical Comparison and Uncertainty Analysis of Two Transient Models for Kick Management in a Backpressure MPD System”, SPE 191345, prepared for presentation at the SPE Norway One Day Seminar held in Bergen, Norway, 18 April
57. O.R. Gabaldon et al., 2017, «Case study: First Experience of Developing an Influx Management Envelope IME for a Deepwater MPD Operation”, SPE/IADC 185289, prepared for presentation at the 2017 IADC/SPE Managed Pressure Drilling & Underbalanced Operations Conference & Exhibition held in Rio de Janeiro, Brazil, 28-20 March 2017
58. Steve Nas, 2010, “Deepwater Managed Pressure Drilling Applications”, SPE 132049, prepared for presentation at the CPS/SPE International Oil & Gas Conference and Exhibition held in Beijing, China, 8-10 June
59. Steve Nas et al., 2009, “Offshore Managed Pressure Drilling Experiences in Asia Pacific”, SPE 119875, prepared for presentation at the SPE/IADC Drilling Conference and Exhibition held in Amsterdam, The Netherlands, 17-19 March
60. Essam Sammat, 2014, “Managed pressure drilling meets challenges of deepwater well”, <https://www.offshore-mag.com/1/volume-74/issue-4/drilling-and-completion/managed-pressure-drilling-meets-challenges-of-deepwater-well/managed-pressure-drilling-meets-challenges-of-deepwater-well-full.html> <04.13.18>
61. IADC: IADC Drilling Manual, 2014, “Deepwater applications of MPD”, <http://www.iadc.org/wp-content/uploads/2015/08/preview-mpub.pdf> <04.13.18>
62. William Bacon et al., 2016, “MPD Dynamic Influx Control Mitigates Conventional Well Control Pitfalls”, SPE/IADC 179185, prepared for presentation at the SPE/IADC Managed Pressure Drilling and Underbalanced Operations Conference and Exhibition held in Galveston, Texas, 12-13 April
63. Y. Kuroda et al., 2017, “Deepwater MPD Operation and Design Method”, SPE 188487, prepared for presentation at the Abu Dhabi International Petroleum Exhibition & Conference held in Abu Dhabi, UAE, 13-16 November
64. Ben Gedge et al., 2013, “Managed Pressure Drilling – A Solution for Drilling the Challenging and Undrillable Wells in Vietnam and South East Asia”, SPE 165775, prepared for presentation at the SPE Asia Pacific Oil & Gas Conference and Exhibition held in Jakarta, Indonesia, 22-24 October

65. John Kozicz, 2017, "What Does "Prepared for MPD" Mean? A Contractors Perspective", IADC, <http://www.iadc.org/wp-content/uploads/2017/09/John-Kozicz-Transocean.pdf> <04.13.18>
66. Transocean, 2008, "Transocean Inc. Announces Contract for GSF Explorer, <http://www.deepwater.com/news/detail?ID=1108991> <04.13.18>
67. Andre Alonso Fernandes, 2015, "MPD/MCD Offshore Application on a Dynamic Positioning Rig", SPE/IADC 173825, prepared for presentation at the SPE/IADC Managed Pressure Drilling and Underbalanced Operations Conference & Exhibition held in Dubai, UAE, 13-14 April
68. Halliburton, GeoBalance® Optimized Pressure Drilling Services, <http://www.halliburton.com/public/ts/contents/Brochures/web/GeoBalance-Catalogue-H012708.pdf> <04.23.18>
69. K.K. Fjelde, J.Frøyen, 2016, A Numerical Study of Gas Kick Migration Velocities and Uncertainty, SPE 180053, prepared for presentation at the SPE Bergen One Day Seminar, Bergen, Norway, 20th April
70. John H. Cohen et.al., 2015, Field Trial of Well Control Solutions with a Dual Gradient Drilling System, SPE/IADC 173822, prepared for presentation at the SPE/IADC Managed Pressure Drilling and Underbalanced Operations Conference and Exhibition, Dubai, UAE, 13-14 April
71. K.L. Smith et.al., 2001, SubSea MudLift Drilling Joint Industry Project: Delivering Dual Gradient Drilling Technology to Industry, SPE 71357, prepared for presentation at the 2001 SPE Annual Technical Conference and Exhibition held in New Orleans, Louisiana, 30 September-3 October
72. Børre Fossli, Sigbjørn Sangesland, 2006, Controlled Mud-Cap Drilling for Subsea Applications: Well-Control Challenges in Deep Waters, SPE 91633, first presented at the 2004 SPE/IADC Underbalanced Technology Conference and Exhibition, Houston, 11-12 October
73. John-Morten Godhavn et.al., 2015, Development and First Use of Controlled Mud Level System in US Deepwater GoM, SPE 173814, prepared for presentation at the SPE/IADC Managed Pressure Drilling and Underbalanced Operations Conference and Exhibition, Dubai, UAE, 13-14 April
74. Mesfin. A. Belayneh, Lecture notes 2017, New Drilling Technologies, Chapter 5, PET 525.
75. Robert Baten et.al., 2016, Installation of a Controlled Mud Level Managed Pressure Drilling System onto a MODU, SPE/IADC 179499, prepared for presentation at the SPE/IADC Managed Pressure Drilling and Underbalanced Operations Conference and Exhibition held in Galveston, Texas, 12-13 April

76. Johan Bysveen et.al, 2017, Planning of an MPD and Controlled Mud Cap Drilling CMCD Operation in the Barents Sea Using the CML Technology, SPE/IADC 185286, prepared for presentation at the 2017 IADC/SPE Managed Pressure Drilling & Underbalanced Operations Conference & Exhibition held in Rio de Janeiro, Brazil, 28-29 March
77. M Noreffendy Jayah et al., 2013, Implementation of PMCD to Explore Carbonate Reservoirs from Semi-Submersible Rigs in Malaysia Results in Safe and Economical Drilling Operations, SPE/IADC 163479, prepared for presentation at the SPE/IADC Drilling Conference and Exhibition held in Amsterdam, The Netherlands, 5-7 March
78. Ken Muir, 2008, Managed Pressure Drilling (MPD) Systems & Applications, [http://www.drillsafe.org.au/06-08\\_pres/DrillSafe\\_Forum\\_Jun08\\_KEEP\\_DRILLING\\_Ken\\_Muir\\_Managed\\_Pressure\\_Drilling\\_Talk.pdf](http://www.drillsafe.org.au/06-08_pres/DrillSafe_Forum_Jun08_KEEP_DRILLING_Ken_Muir_Managed_Pressure_Drilling_Talk.pdf) <05.07.18>
79. Schlumberger, 2018, Carbonate Reservoirs, [https://www.slb.com/services/technical\\_challenges/carbonates.aspx](https://www.slb.com/services/technical_challenges/carbonates.aspx) <05.07.18>
80. R. Urselmann et al., 1999, Pressured Mud Cap Drilling: Efficient Drilling of High-Pressure Fractured Reservoirs, SPE/IADC 52828, prepared for presentation at the 1999 SPE/IADC Drilling Conference held in Amsterdam, Holland, 9-11 March
81. Benny et al., 2013, Combining Pressurized Mud Cap Drilling (PMCD) and Early Kick Detection (EKD) Techniques for Fractured Formations Overlying a High Pressure Reservoir in Offshore Kalimantan, SPE 165893, prepared for presentation at the SPE Asia Pacific Oil & Gas Conference and Exhibition held in Jakarta, Indonesia, 22-24 October
82. R. A. Tomita et al., 2015, Successful Case History of Drilling Through Major Loss Zone Using MPD/PMCD Techniques on a Santos Basin Well, SPE 174836, prepared for presentation at the SPE Annual Technical Conference and Exhibition held in Houston, Texas, 28-30 September
83. Siddharth Misra, 2015, Pressurized Mudcap Drilling, <https://www.epmag.com/pressurized-mudcap-drilling-788971#p=full> <05.07.18>
84. Weatherford, 2018, Managed Pressure Drilling, <https://www.weatherford.com/en/products-and-services/drilling/closed-loop-drilling/managed-pressure-drilling/> <05.07.18>
85. Culen et al., 2016, Evolution of the MPD Operations Matrix: The Influx Management Envelope, SPE/IADC 179191, presented at the 2016 SPE/IADC Managed Pressure Drilling and Underbalanced Operations Conference and Exhibition in Galveston, TX



86. Drilling Contractor, 2011, RCD for DP drillship takes MPD deeper,  
<http://www.drillingcontractor.org/rcd-for-dp-drillship-takes-mpd-deeper-9925> <05.07.18>
87. I. Barr Aas et al., 2016, Successful Use of Sophisticated Flow Modelling in the Planning and Operational Phase of Drilling, Liner Running and Cementing Operations: All in Managed Pressure Mode, SPE 181474, prepared for presentation at the SPE Annual Technical Conference and Exhibition held in Dubai, UAE, 26-28 September
88. Intan Azian A. Aziz, 2014, MPD Application on ERD Well in Offshore Peninsular Malaysia – Reducing Cyclical Fatigue Forces Across the Weak Formations by Managing the ECD, SPE/IADC 168951, prepared for presentation at the SPE/IADC Managed Pressure Drilling and Underbalanced Operations Conference and Exhibition held in Madrid, Spain, 8-9 April
89. Yongki Suharya Dipura et.al., 2018, Pressurized Mud Cap Drilling Drastically Improves Drilling Efficiency in Exploration Well, South Sumatra, SPE/IADC 189398, prepared for presentation at the SPE/IADC Middle East Drilling Technology Conference and Exhibition held in Abu Dhabi, UAE, 29-31 January
90. R. Urselmann et.al., 1999, Pressurized Mud Cap Drilling of High-Pressure Fractured Reservoirs, SPE/IADC 52828, prepared for presentation at the 1999 SPE/IADC Drilling Conference held in Amsterdam, Holland, 9-11 March
91. J.H. Terwogt et.al., 2005, Pressurized Mud Cap Drilling from A Semi-Submersible Drilling Rig, SPE/IADC 92294, prepared for presentation at the SPE/IADC Drilling Conference held in Amsterdam, The Netherlands, 23-25 February
92. Michael Runtuwene et.al., 2009, Pressurized Mud Cap Drilling Drastically Reduces Non-Productive Time in Soka Field, South Sumatera, SPE/IADC 125311, prepared for presentation at the SPE/IADC Middle East Drilling Technology Conference & Exhibition held in Manama, Bahrain, 26-28 October
93. R.A. Tomita et.al., 2015, Successful Case History of Drilling Through Major Loss Zone Using MPD/PMCD Techniques on a Santos Basin Well, SPE 174836, prepared for presentation at the SPE Annual Technical Conference and Exhibition held in Houston, Texas, USA, 28-30 September
94. Bob Goodwin et al., 2014, MudCap Drilling: New Variations, Drivers, Limitations, and Lessons Learned – Case Histories, SPE/IADC 168956, prepared for presentation at the SPE/IADC Managed Pressure Drilling and Underbalanced Operations Conference and Exhibition held in Madrid, Spain, 8-9 April

95. IADC, 2011, Pressurized Mud Cap Drilling, <http://www.iadclexicon.org/pressurized-mud-cap-drilling/> <05.09.2019>
96. Yongki Suharya Dipura et.al., 2018, Pressurized Mud Cap Drilling Drastically Improves Drilling Efficiency in Exploration Well, South Sumatra, SPE/IADC 189398, prepared for presentation at the SPE/IADC Middle East Drilling Technology Conference and Exhibition held in Abu Dhabi, UAE, 29-31 January
97. N. H. Houg et al., 2016, Successful PMCD Application Significantly Improved Drilling Efficiency on Carbonate Drilling, IADC/SPE 180658, prepared for presentation at the IADC/SPE Asia Pacific Drilling Technology Conference and Exhibition held in Singapore, 22-24 August
98. Exam Exercises, PET 510, UiS, 2017
99. Svalex Expedition, K. K. Fjelde
100. Halliburton, Optimized Pressure Drilling, Continuous Circulation Systems, Circulating Sub, [http://www.halliburton.com/public/ts/contents/Data\\_Sheets/web/H/ecd-circ-sub.pdf](http://www.halliburton.com/public/ts/contents/Data_Sheets/web/H/ecd-circ-sub.pdf) <03.16.18>
101. Halliburton, Optimized Pressure Drilling, Continuous Circulation Systems, e-cd™ Diversion Manifold, [http://www.halliburton.com/public/ts/contents/Data\\_Sheets/web/H/ecd-div-man.pdf](http://www.halliburton.com/public/ts/contents/Data_Sheets/web/H/ecd-div-man.pdf) <03.16.18>
102. Felipe de Souza Terra et al., 2017, Prediction Model for Gas Migration in Well During PMCD Operation, SPE/IADC 185276, prepared for presentation at the 2017 IADC/SPE Managed Pressure Drilling & Underbalanced Operations Conference & Exhibition held in Rio de Janeiro, Brazil, 28-29 March
103. Eirik Aas Lind, 2017, Master's Thesis: Simulation and Modelling of Injectivity during Pressurized Mud Cap Drilling with the AUSMV Numerical Scheme, [https://brage.bibsys.no/xmlui/bitstream/handle/11250/2462418/Lind\\_Eirik\\_Aas.pdf?sequence=1&isAllowed=y](https://brage.bibsys.no/xmlui/bitstream/handle/11250/2462418/Lind_Eirik_Aas.pdf?sequence=1&isAllowed=y) <05.27.18>
104. R. Rommetveit et.al., 2005, Ultradeepwater Hydraulics and Well-Control Tests with Extensive Instrumentation: Field Tests and Data Analysis, SPE 84316, prepared for presentation at the SPE Annual Technical Conference and Exhibition held in Denver, Colorado, 5-8 October
105. E.Claudey et al., 2018, Experience Using Managed Pressure Cementing Techniques with Riserless Mud Recovery and Controlled Mud Level in the Barents Sea, SPE 191344, prepared for presentation at the SPE Norway One Day Seminar held in Bergen, Norway, 18 April

106. Behzad Elahifar, 2017, Successful Deep Water Drilling (MPD), Early Kick Detection and Performing Managed Pressure Cementing with CML (Controlled Mud Level) System in GOM and North Sea, SPE 184627, prepared for SPE/IADC Drilling Conference and Exhibition, The Hague, The Netherlands, 14-16 March

## Appendix – Job Distribution

The following is an overview of which chapters the two authors have written.

- Acknowledgement: Ida and Elisabeth
- Summary: Ida and Elisabeth
- Nomenclature: Ida and Elisabeth
- Introduction: Ida and Elisabeth
- Chapter 1: Ida
- Chapter 2: Elisabeth
- Chapter 3: Ida
- Chapter 4:
  - 4.1: Ida
  - 4.2: Ida and Elisabeth
  - 4.3: Ida and Elisabeth
  - 4.4: Ida and Elisabeth
  - 4.5: Elisabeth
  - 4.6: Ida
  - 4.7: Elisabeth
- Chapter 5: Ida and Elisabeth