



University of  
Stavanger

Faculty of Science and Technology

## MASTER'S THESIS

Study program/ Specialization:  Petroleum technology Well engineering	Spring semester, 2018  Open / <del>Restricted access</del>
Writer:  Dmitrii Zhambrovskii	..... (Writer's signature)
Faculty supervisor: Jan Aage Aasen  External supervisor(s): Gorm Liland (Halliburton)	
Title of thesis:  <b>Application of Multilateral Wells as an alternative solution for costs optimization</b>	
Credits (ECTS): 30	
Key words:  <ul style="list-style-type: none"><li>• Multilateral well</li><li>• Horizontal well modelling</li><li>• Total construction costs</li><li>• Oil production rate</li></ul>	Pages: 60

## Acknowledgments

I would like to express gratitude to Professor Jan Aasen for his time and guidance devoted to the thesis.

I would like to express gratitude to Gorm Liland for his support in foundation of the thesis problem.

I would like to express gratitude to Professor Francisco Porturas for his support of the thesis.

I would like to express gratitude to professor Rune Time for his support in establishing calculations.

## Abstract

Field completion techniques have progressed over the last twenty years. Today, different methods of well drilling can reduce total costs spent on single well construction. Multilateral wells is the primary example of advanced completion technologies, which designed to reduce costs per barrel extracted.

A multilateral well is a drilling technique, which can create well structure similar to fish bone system. It consists of one mother bore connected with a number of single horizontal sections, called laterals, which designed to access more reservoir areas without a need to construct another well.

However, oil reservoirs with high permeability can provide the well with great inflow, resulting in increased velocities of reservoir fluid in the piping system. Individual laterals will create an additional pressure differential at junction, which will lead to loses of well performance.

The goal of the thesis is to estimate productivity of a multilateral well in reservoirs with different fluid mobility and provide optimization example in case of a multilateral type of field development selected instead of two single horizontal wells.

Solution method is to use theory of well modelling and perform flow calculations to estimate production performance of multilateral well and single horizontal with an assumption of reservoir and fluid parameters.

Solution method for costs optimization is to establish ratio of total construction costs between single horizontal well and corresponding multilateral.

Simulation has been performed in Matlab by establishing a reservoir model containing undersaturated oil.

## List of Figures

Figure 1: Field completion by multilaterals (Elyasi, 2016) .....	1
Figure 2: Configuration of multilateral well (A.D. Hill, 2007).....	2
Figure 3: Types of junction (Flatern, 2016) .....	4
Figure 4: Selection criteria according to reservoir condition (Ali. A. Garrouch, 2005) .....	6
Figure 5: Decision diagram for multilateral candidate (A.D. Hill, 2007) .....	7
Figure 6: Pressure gradient (Holm, 1998).....	9
Figure 7: Classification of horizontal well based on drilling radius .....	10
Figure 8: Ellipsoidal drainage volume of a horizontal well .....	11
Figure 9: 2d inflow (Joshi, 1991) .....	12
Figure 10: Production case: big tubing diameter .....	16
Figure 11: Production case: small tubing diameter .....	16
Figure 12: Production case: weak formation.....	17
Figure 13: Solution for well deliverability .....	17
Figure 14: 3d modelling case: Single Well .....	25
Figure 15: 3d modelling case: Dual lateral well .....	25
Figure 16: 2d modelling case .....	25
Figure 17: Applying vectors to fill pressure and position along the well .....	27
Figure 18: Simplified picture of the modelling case in Matlab.....	28
Figure 19: Calculation of the pressure drop in horizontal well.....	28
Figure 20: Dual lateral well. Calculation of the pressure drop in each node .....	29
Figure 21: Inflow performance of the reservoir model (figure from Matlab).....	30
Figure 22: Production performance: 4.77''ID, k=100 [mD] (figure from Matlab) .....	31
Figure 23: Production performance: 6.18''ID, k=100 [mD] (figure from Matlab) .....	32
Figure 24: Comparative chart. Production rate performance. Case 1: Low Fluid Mobility ....	33
Figure 25: Production performance: 6.18''ID, k=500 [mD] (figure from Matlab) .....	34
Figure 26: Comparative chart. Production rate performance. Case 2: High Fluid Mobility....	35
Figure 27: Production performance: 6.18''ID, k=1000 [mD] (figure from Matlab) .....	36
Figure 28: Comparative chart. Production rate performance. Case 3: Very High Mobility ....	37
Figure 29: Comparative chart of Dual lateral performance. Optimization example.....	40

## List of Tables

Table 1: Classification of multilaterals by TAML .....	5
Table 2: Global distribution of price per junction (A.D. Hill, 2007) .....	5
Table 3: Well Length limitation according to drilling technique.....	11
Table 4: Optimization criteria .....	18
Table 5: Ratio of total construction costs.....	22
Table 6: Savings percentage of Multilateral type compared to two single wells.....	23
Table 7: Well flow correlations (Beggs, 2003) .....	24
Table 8: List of constant parameters used for modelling in Matlab.....	26
Table 9: List of input parameters used for modeling in Matlab.....	26
Table 10: List of solutions obtained in Matlab .....	29
Table 11: Results from simulation. Case 1: Low Fluid Mobility .....	32
Table 12: Results from simulation. Case 2: High Fluid Mobility .....	34
Table 13: Results from simulation. Case 3: Very high fluid mobility .....	36
Table 14: Limits of production performance y and total construction costs x.....	41

## Nomenclature

$C$  = construction costs of single horizontal well

$v$  = costs of vertical section

$h$  = costs of horizontal section

$Q$  = production performance of single horizontal well

$x$  = construction costs of multilateral

$y$  = production performance of multilateral

$n$  = number of laterals

AOF = absolute open flow

IPR = inflow performance relation

TPR = tubing performance relation

STB = stock tank barrel

$P_r$  = reservoir pressure

$k$  = reservoir permeability

$P_{wf}$  = bottom hole flowing pressure

ID = inner diameter of production tubing

$h$  = reservoir height

$R_e$  = drainage radius

$S$  = skin factor

GOR = gas oil ratio

$\Delta P$  = drawdown pressure

$\mu$  = fluid viscosity

$B$  = formation volume factor

1000 (1000USD) = 1 million dollars

# Contents

Acknowledgments .....	ii
Abstract .....	iii
List of Figures .....	iv
List of Tables.....	v
Nomenclature .....	vi
Part 1. Introduction.....	1
1.1 Multilateral type of field development .....	1
1.2 Lower completion methods.....	3
1.3 Price of junction .....	5
1.4 Selection criteria .....	6
Part 2. Chapters of well modelling.....	8
2.1 Pseudo steady state .....	8
2.2 Overpressure and underpressure reservoirs .....	8
2.3 Permeability .....	9
2.4 Horizontal Well Length Limitation .....	10
2.6 Skin factor.....	12
2.7 Productivity index.....	13
2.8 Inflow Performance .....	14
2.9 Outflow performance .....	14
Part 3. Optimization Model.....	18
3.1 Modelling total construction costs.....	18
3.2 Modelling well performance .....	24
3.2.1 Assumptions.....	24
3.2.2 Inputs and constants.....	26
3.2.3 Calculating by iterations method .....	27
3.2.4 List of solutions.....	29
3.3 Outflow performance.....	31
3.3.1 Low fluid mobility .....	31
3.3.2 High fluid mobility .....	34
3.3.3 Very high fluid mobility .....	36
3.4 Optimization example.....	38
Results and discussions .....	41
References .....	42
Appendix .....	44

# Part 1. Introduction

## 1.1 Multilateral type of field development

Horizontal wells have proved their efficiency in field development, however construction of single wells can result in high total costs and low compensation of oil return. Formations with complex bedding structure can contain a vast amount of oil and gas in small or isolated blocks. Production in such formations by horizontal wells will require construction of a number of single wells located in individual reservoir zones. Multilateral wells can access such reservoirs by drilling lateral sections from one vertical mother bore.

Mother bore can involve a number of laterals completed toward different location of a reservoir that allow bypassing impermeable barriers and producing oil from each lateral interconnected. Such kind of field completion technique can reduce efforts and save time for oil companies, which they spend on planning and organizing drilling of another single well.

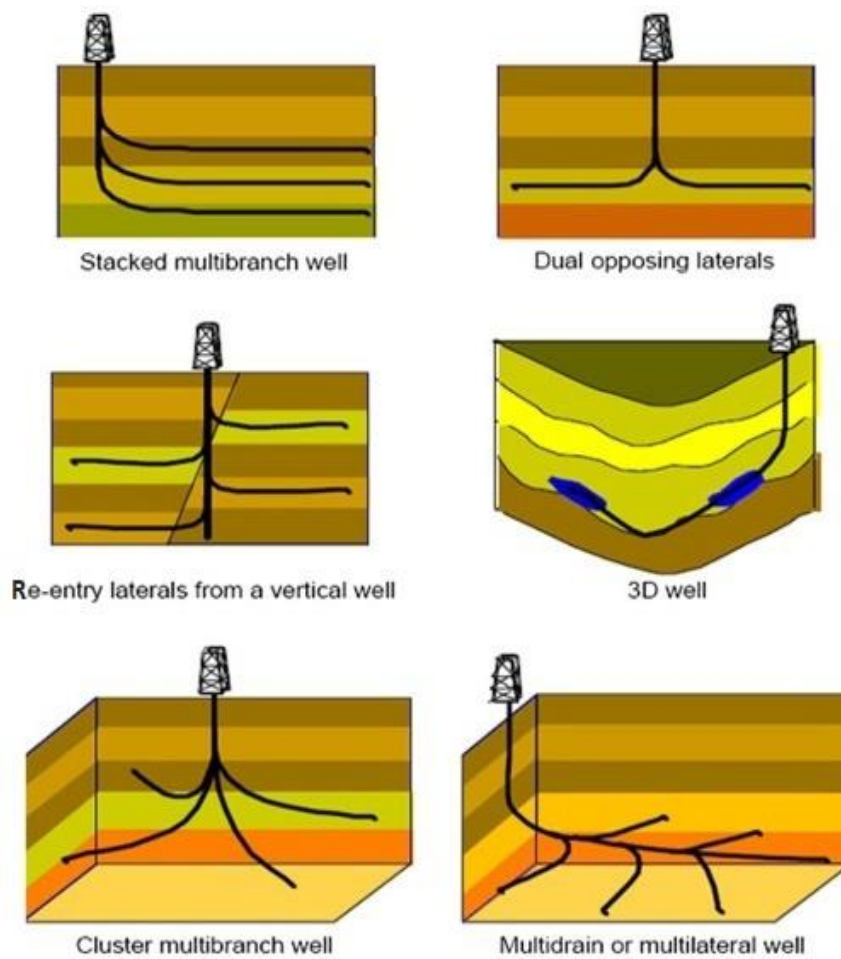

Figure 1: Field completion by multilaterals (Elyasi, 2016)



Companies spend a lot on reservoir stimulation techniques to increase single well productivity in formations with low fluid mobility. Multilateral wells can benefit in such formations because tight reservoir fluid will escape toward each lateral section uniting in total flow and improving well performance without stimulation.

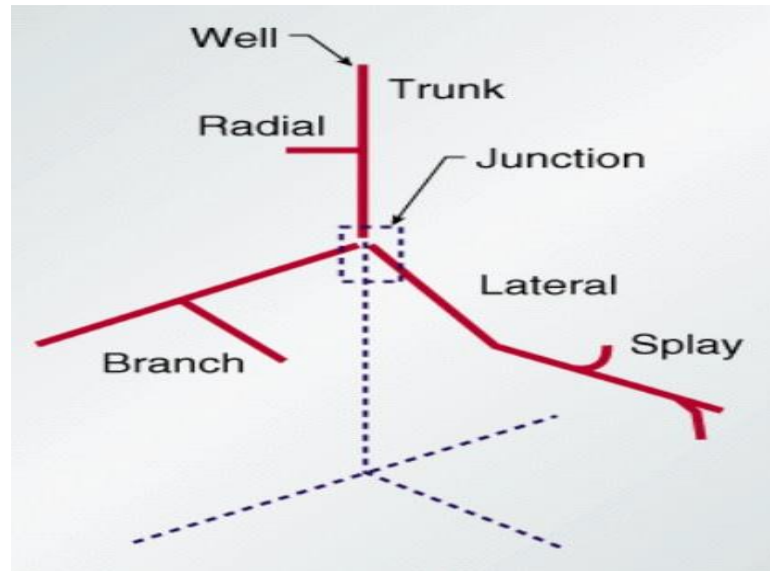

Figure 2: Configuration of multilateral well (A.D. Hill, 2007)

Increasing the length of individual lateral in a reservoir implies different levels of reservoir exposure. This property of a multilateral can carry a revitalizing effect on old single wells, which have lost their performance after oil production period. Construction of lateral sections in old producers will create additional drainage area increasing total inflow capacity and improving the well.

One example found in articles – Zuata field in Venezuela (Stalder, York, & al., 2001). Reservoirs of the field characterized with complex depositional structures and high fluid viscosity. Production performance of single wells was less than expected. Variety of complex multilateral configurations were drilled primarily to regenerate reservoir inflow performance. Dual lateral and triple lateral types have been performed through careful geosteering in Zuata field to access more reservoir areas. This resulted in an increase of oil production rate per well.

Multilateral field development extensively applied in regions of the North Sea. Example is Tern field located in the British Sector (M.J.Roberts, A.Kirkwood, & J.Bedford, 1998).

Well operations are expensive in Arctic region and wellbore configurations are restricted. Drilling multilaterals in Tern field allowed to increase profitability in poor formations and reducing high potential costs for drilling additional single wells.

Multilaterals gain more popularity around the world. With unstable oil price, it can allow companies to reduce costs per barrel extracted, especially when meter to construct a single well is great in price.

## **1.2 Lower completion methods**

Each individual lateral section can differ in type of lower completion. However, completion methods for a multilateral well are same as for a single horizontal.

Completion method will depend on type of formation.

### Consolidated formations

- Open hole
- Predrilled or slotted liner
- Predrilled or slotted liner with ECP (External Casing Packer)
- Cased, cemented and perforated

### Unconsolidated formations

- Open hole with predrilled liner and Stand Alone Screen
- Open hole with Stand Alone Screen
- Open hole with Gravel Pack

To support a main bore stability at junction and to allow reentry for work over operations completion method should be carefully selected, since all lateral sections are connected with the main bore and low quality completion at one lateral can deteriorate productivity of the whole well.

Junction is of primary concern when planning a lateral section. Low junction level in unconsolidated formations may result in poor pressure integrity between a main bore and a lateral, which can lead to collapse or extra efforts to perform a treatment procedure.

Therefore, when designing lateral section, type of junction must correspond to formations strength.

To classify all types of multilateral wells according to the level of junction Operators and service companies have created a consortium – Technology Advancement of Multilaterals (TAML).

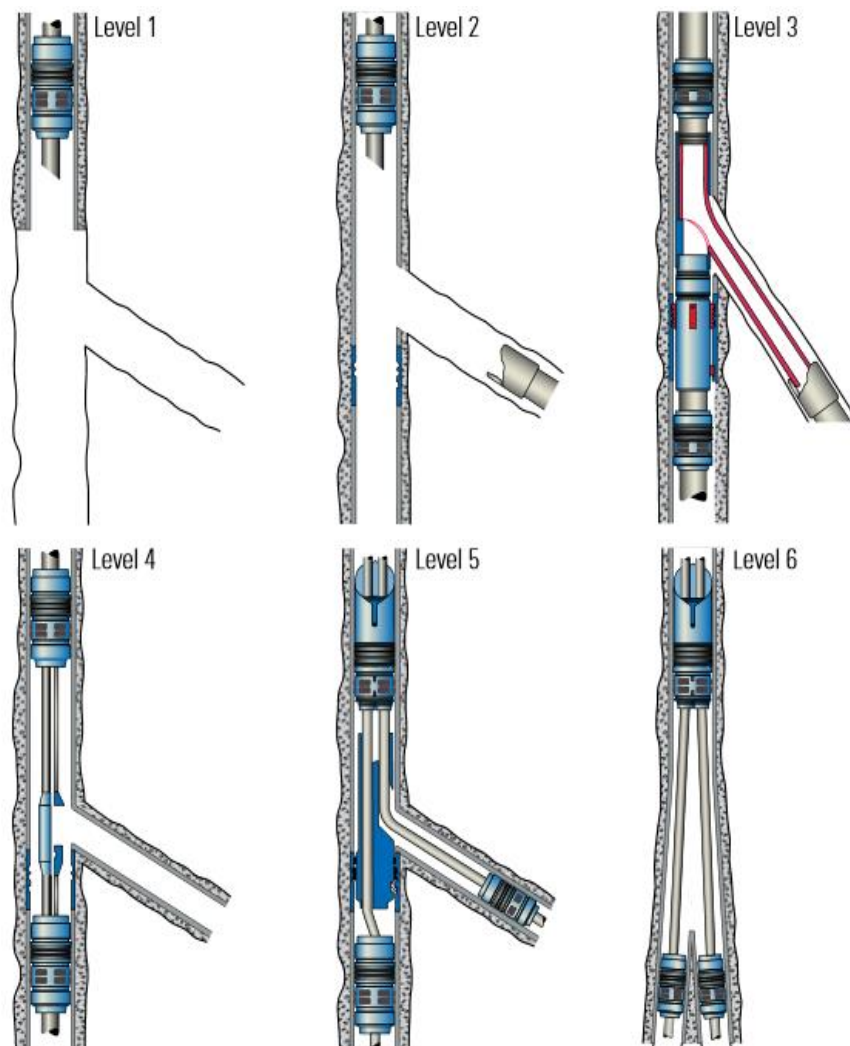

Figure 3: Types of junction (Flatern, 2016)

Table 1: Classification of multilaterals by TAML

<b>Junction Class</b>	<b>Level Description</b>	<b>Purpose</b>
Level 1	Open main bore and open lateral	Produce from consolidated formations
Level 2	Cemented main bore and open lateral	Reduce risk for collapse and provide isolation between laterals
Level 3	Cemented main bore and open liner	Allow reentry in consolidated formations
Level 4	Cemented main bore and cemented lateral	Produce from both consolidated and unconsolidated formations
Level 5	Cemented main bore and cemented lateral supported with two packers on production casing	Provide pressure integrity and hydraulic isolation
Level 6	Cemented dual main bore with liners or production casing.	Designed for experiments

### 1.3 Price of junction

Price of junction can differ for offshore and onshore wells. To get an overview from 2007 for onshore wells represented:

Table 2: Global distribution of price per junction (A.D. Hill, 2007)

<b>Degree of Junction</b>	<b>Global Use</b>	<b>Price per Junction [1000USD]</b>
Level 1	2500+	< 20
Level 2	1000+	28 – 50
Level 3	350+	75 – 200
Level 4	170+	80 – 400
Level 5	40+	500 – 1300
Level 6	16	160 – 1000

### 1.4 Selection criteria

To construct a multilateral well, first it is necessary to assure the possibility of adequate horizontal drilling in a reservoir. Selection criteria for a multilateral based on reservoir characteristics and near wellbore conditions.

Garrouch et al. have defined selection criteria for a multilateral well candidate. It is represented as a diagram of inputs:

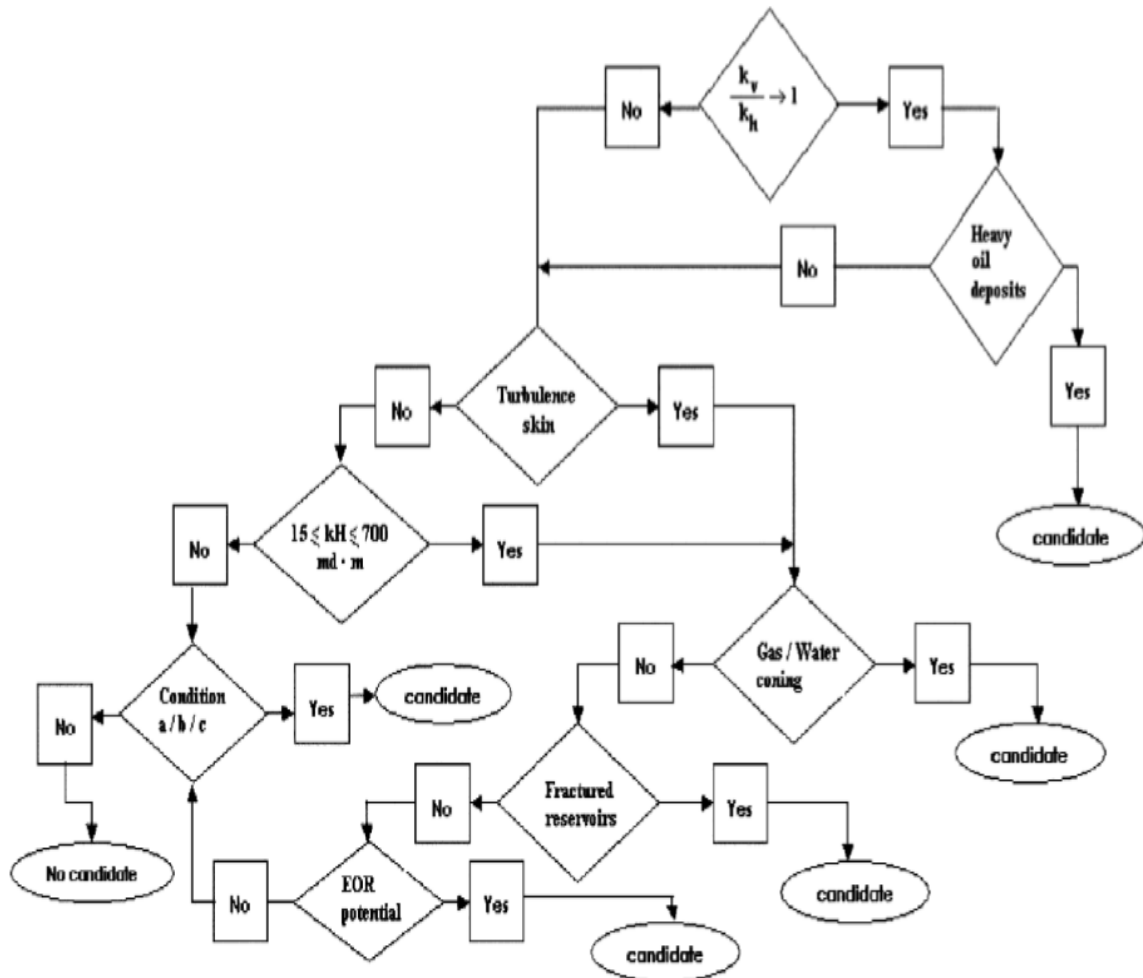

Figure 4: Selection criteria according to reservoir condition (Ali. A. Garrouch, 2005)

It can be seen from the diagram that in case of isotropic reservoir and tight fluid formation a multilateral becomes candidate for a field development without considering any further reservoir conditions. Therefore, isotropic reservoir case will be assumed in modelling part to satisfy selection criteria.

Another useful information found in source is a decision making tree. It allows to estimate potential losses and start-up capital before drilling a multilateral.

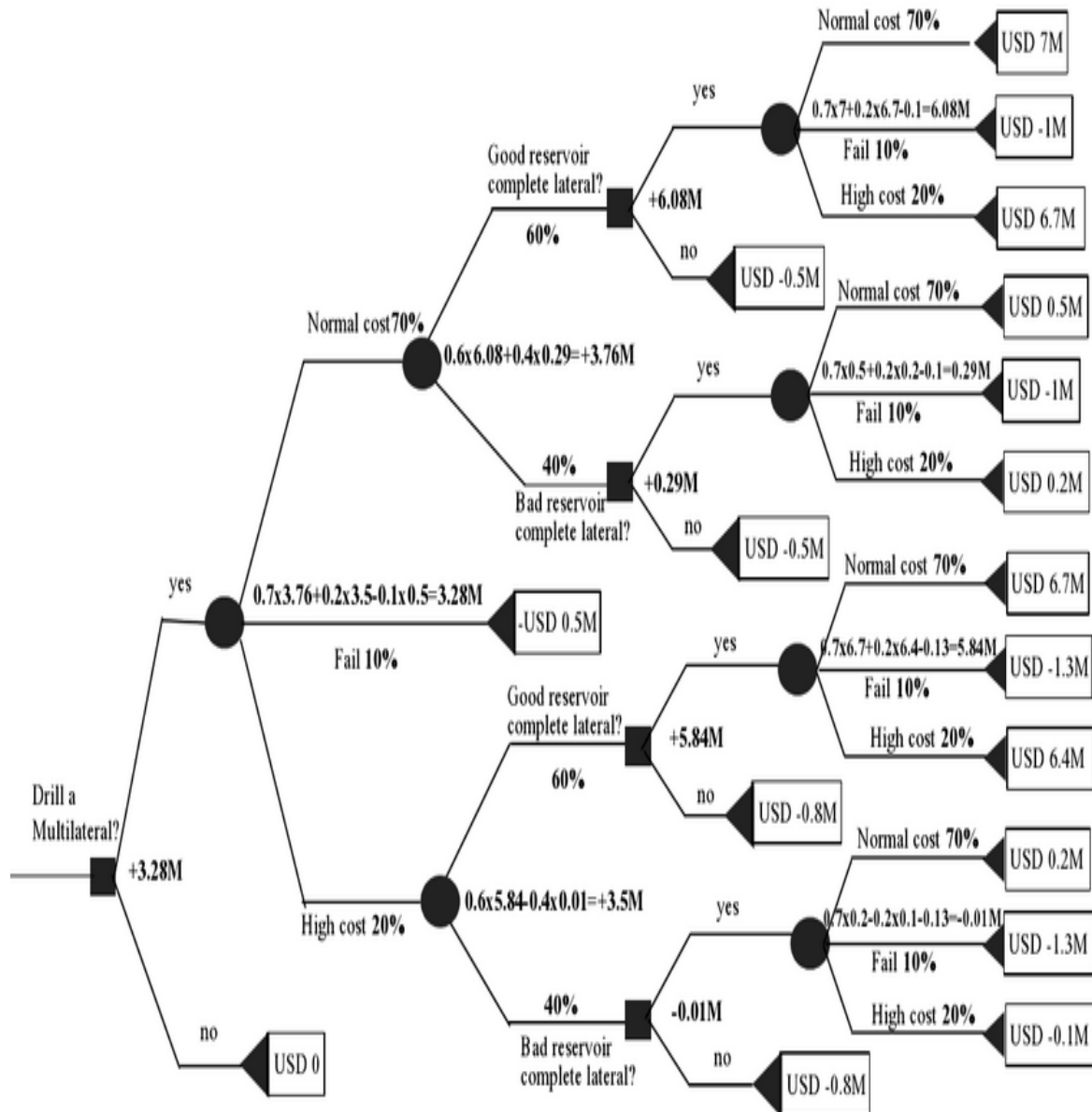

Figure 5: Decision diagram for multilateral candidate (A.D. Hill, 2007)

The diagram consists of three nodes:

- the terminal, represented by triangles, implies a pay-off value in case of fulfilled completion
- the chance, represented by ovals, implies a risk and degree of loss and gain
- the decision, represented by squares, implies a starting amount before making another decision

## Part 2. Chapters of well modelling

Modelling of multilateral well is similar to modelling of horizontal well if each lateral section considered individually in reservoir block. Therefore, first step is to define a reservoir and its bedding depth to estimate dimensions of the future borehole.

This part will cover chapters of reservoir engineering that were used for calculations.

### 2.1 Pseudo steady state

Pseudo-steady state is a reservoir production stage, in which no flow occurs in the outer boundary of a reservoir. At this stage, flow of fluid into the well will be stabilized by pressure, which is linear function of time. This implies:

$$\frac{\partial P}{\partial t} = \text{constant} \quad (1)$$

Drawdown pressure will initiate flow toward the wellbore and its value is defined as the difference between a reservoir pressure and the bottom-hole flowing pressure:

$$\Delta P = P_{res} - P_{wf} \quad (2)$$

During production, decrease in reservoir pressure will lead to decrease in drawdown. Inflow capacity of the well will be reduced. In order to estimate well performance at specific amount of inflow from reservoir flow calculation will start at fixed moment of time  $t = 1$ , which will correspond to relation (1).

### 2.2 Overpressure and underpressure reservoirs

Overburden pressure increases accordingly with lithostatic pressure gradient, which is a linear function of rock density. Reservoirs containing fluids obtain gradient value less than lithostatic this property has been used to define bedding depth of the reservoir model.

Overpressure reservoirs are characterized with high pressures and relatively low bedding depth. This occurs because overburden create a high load on reservoir pore structure, which is caused by increased rate of rock sedimentation in environment.

Underpressure reservoirs are characterized with low pressures on relatively high bedding depth. This occurs when reservoir pores are relaxed and experience less load from overburden.

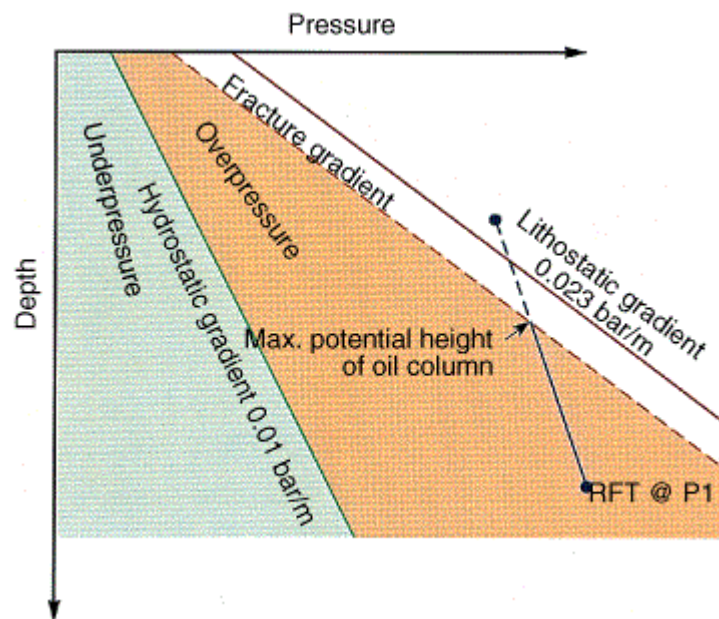

Figure 6: Pressure gradient (Holm, 1998)

### 2.3 Permeability

Ability of rocks to filtrate fluid through its mass characterized by different types of grains matrix of the rock, which in micro level represented as a solid structure with interconnected channels. Grains are characterized with uniformity of their disposition and their size of each solids. Permeability and porosity relation of a reservoir will depend on grains matrix.

In reservoir engineering permeability is considered to vary along spatial coordinates x-y-z. In this case, oil reservoir becomes anisotropic and characterized with factor of anisotropy

$$\beta = \sqrt{\frac{k_h}{k_v}} \quad (3)$$



Reservoirs relate to isotropic if its permeability does not change along x-y-z direction i.e.  
 $k_h = k_v = k$ .

$$\beta = \sqrt{\frac{k_h}{k_v}} = 1 \quad (4)$$

In optimization model permeability will be the key parameter for simulating reservoir inflow performance.

## 2.4 Horizontal Well Length Limitation

Horizontal well is drilled parallel to the reservoir stratification plane and its productivity function will depend on the well length. To select appropriate well length that will fit a reservoir block, turning radius  $R$  of the well will create a limitation. Classification of wells with respect to the drilling technique are given by S. D. Joshi (Joshi, 1991).

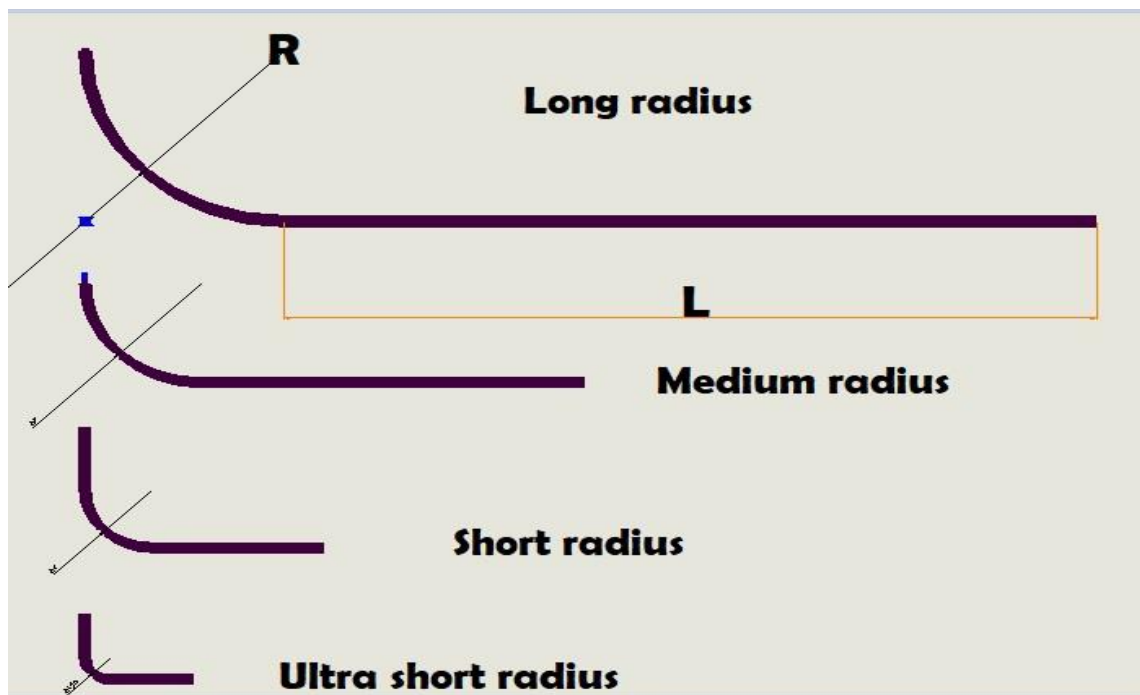

Figure 7: Classification of horizontal well based on drilling radius

Table 3: Well Length limitation according to drilling technique

Drilling Technique	Turning Radius	Completion	Well Length
Ultrashort	$R = 1 - 2$ ft	Perforated tubing or gravel pack	$L = 100 - 200$ ft
Short Radius	$R = 20 - 40$ ft	Open hole or slotted liner	$L = 100 - 800$ ft
Medium Radius	$R = 300 - 800$ ft	Open hole slotted liner or cemented and perforated liner	$L = 1000 - 4000$ ft
Long Radius	$R \geq 1000$ ft	Selective completion using cementing&perforation	$L = 1000 - 4000$ ft

### 2.5 Well Length criteria

During production horizontal well drains an ellipsoid. Major axis **a** is the distance between half of the horizontal section and drainage boundary.

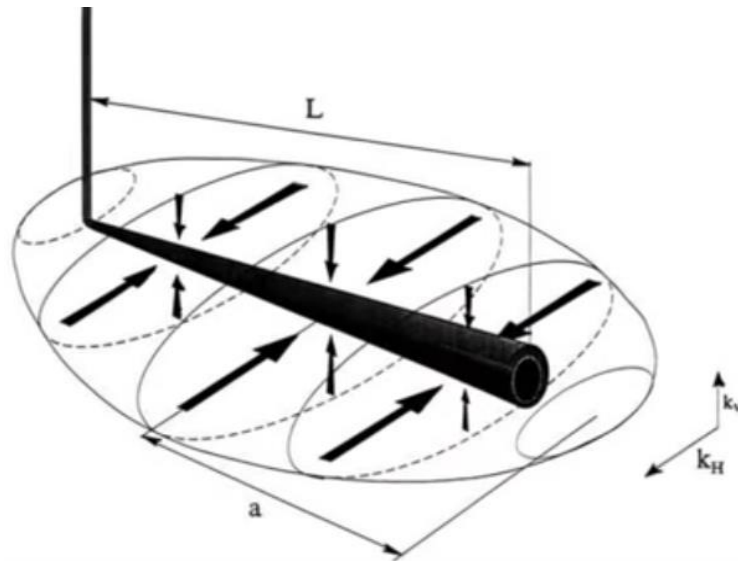

Figure 8: Ellipsoidal drainage volume of a horizontal well

In order to establish criteria for the well length, 3D case is divided into combination of 2D inflow scenarios:

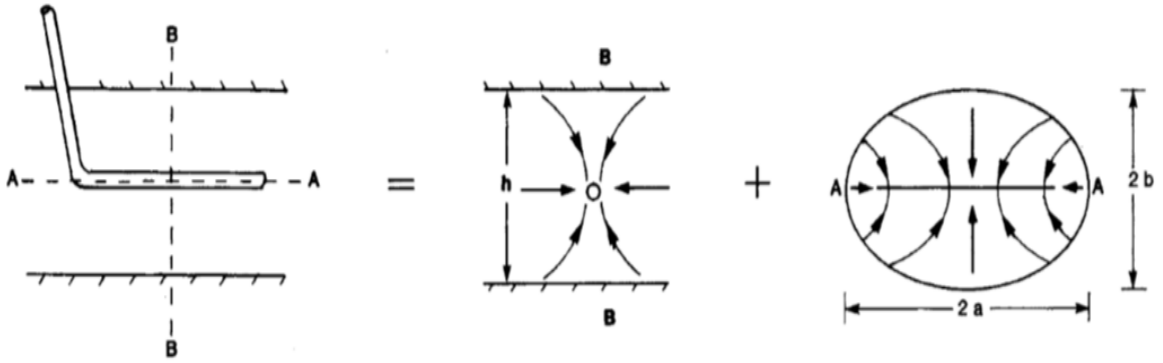

Figure 9: 2d inflow (Joshi, 1991)

Inflow to the well and well length criteria has been derived by Joshi:

$$q = \frac{0.00708kh\Delta P/\mu B}{\ln \left| \frac{a + \sqrt{a^2 - \frac{L^2}{2}}}{\frac{L}{2}} \right| + \frac{h}{L} \ln \left| \frac{h}{2R_w} \right|} \quad (5)$$

Major axis of the drained ellipse is defined:

$$a = \left( \frac{L}{2} \right) \sqrt{\left( \frac{1}{2} + \sqrt{\frac{1}{4} + \frac{1}{0.5 \left( \frac{L}{R_e} \right)^4}} \right)} \quad (6)$$

$$\frac{L}{2} < 0.9R_{eh}, \quad \text{for } \frac{L}{h} \gg 1 \quad (7)$$

Equation (5) relates to isotropic reservoir with constant permeability. For anisotropic reservoir case Economides et al. (1991) included anisotropic factor  $\beta$  into Joshi's equation:

$$q = \frac{2\pi kh\Delta P/\mu B}{\ln \left| \frac{a + \sqrt{a^2 - \frac{L^2}{2}}}{\frac{L}{2}} \right| + \frac{\beta h}{L} \ln \left| \frac{\beta h}{2R_w} \right|} \quad (8)$$

## 2.6 Skin factor

The concept of skin factor has been introduced in reservoir engineering to explain why measured bottom hole flowing pressure is usually less than predicted theoretically. Many authors indicate that this is due to a reservoir zone with reduced permeability, which originates near wellbore after drilling. Particles of drilling mud can plug pore spaces, which

will result in additional pressure differential in a wellbore. Negative value of skin factor implies that additional pressure differential is acting toward a wellbore, facilitating inflow to the well. Value of skin factor is positive when additional pressure differential will act against inflow from reservoir and its value tends toward infinity if a wellbore experienced great damage after drilling.

Joshi's relationship of skin factor has been applied for modelling:

$$S = \ln \left| \frac{a + \sqrt{a^2 - (L/2)^2}}{L/2} \right| + \frac{\beta h}{L} \ln \left| \frac{\beta h}{2r_w} \right| - \ln \left| \frac{r_e}{r_w} \right| \quad (9)$$

## 2.7 Productivity index

Productivity defined as amount of flow rate obtained on the surface per unit change of drawdown pressure:

$$J = \frac{q}{P_{res} - P_{wf}} = \frac{q}{\Delta P} \quad (10)$$

For Pseudo-Steady reservoir stage, Joshi defined productivity index as a constant value:

$$J = \frac{2\pi kh/\mu B}{\ln \left| \frac{a + \sqrt{a^2 - \frac{L^2}{2}}}{\frac{L}{2}} \right| + \frac{\beta h}{L} \ln \left| \frac{\beta h}{2R_w} \right|} \quad (11)$$

In order to match practical field values  $2\pi$  is replaced with 0.007078:

$$J = \frac{0.007078kh/\mu B}{\ln \left| \frac{a + \sqrt{a^2 - \frac{L^2}{2}}}{\frac{L}{2}} \right| + \frac{\beta h}{L} \ln \left| \frac{\beta h}{2R_w} \right|} \quad (12)$$

## 2.8 Inflow Performance

Inflow performance of reservoir arrives from Darcy' law of linear permeability:

$$q = \frac{k\Delta P^*A}{\mu \Delta L} \quad (13)$$

To estimate inflow capacity of the wellbore Darcy's equation can be expressed through productivity index derived by Joshi:

$$q = J\Delta P \quad (14)$$

Linear relation (13) holds true only for one-phase fluid. Realistic scenario is when gas dissolved in oil and restrained by pressure. When pressure in the wellbore becomes less than fluid bubble pressure gas will start to come out of oil solution, breaking linear relationship in (13). Inflow performance of reservoir in case of multi-phase fluid can be determined by Vogel's equation:

$$\frac{Q}{AOF} = \left(1 + 0.2 \frac{P_{wf}}{P_{res}} + 0.8 \frac{P_{wf}}{P_{res}}\right) \quad (15)$$

To estimate well productivity IPR curve combined together with TPR curve, which is obtained by analysis of outflow performance of production tubing. This will be a method of solution to estimate oil production rate of horizontal and multilateral well.

## 2.9 Outflow performance

Optimization of the piping system, which provide vertical lift to the surface, is performed by selecting a point in desirable part of a lifting component and estimating pressure drop behavior with respect to diameter of production tubing. Change of pressure at one lifting component can significantly affect pressure at another component. Producing capacity of the piping system will be affected negatively if too big pressure drop occurs in the component.

Decrease in lifting pressure occurs because reservoir fluid is compressible and difference in phase velocity results in high friction against a pipe wall. To determine location of pressure drop, which can be optimal for oil production, reference pressures are fixed at the given moment of time. In the modelling part, reference pressures are total pressure drop available to the system and being the difference between reservoir pressure and pressure at separator:

$$\Delta P_{total} = P_{res} - P_{sep} \quad (16)$$

To determine an optimal pressure drop in the piping system, first step is to suppose which lifting component is most exposed to pressure changes. Most commonly selected components are flow control valves and flow line.

After component has been selected, it is represented as a node containing constant pressure. Inflow to the node will be reservoir pressure minus pressure drop at upward tubing. Outflow from the node will be pressure at separator plus pressure drop at flowline at downward tubing:

$$P_{node} = P_{res} - P_{down} \quad (17)$$

$$P_{node} = P_{sep} + \Delta P_{flowline} + \Delta P_{down} \quad (18)$$

If reservoir pressure and pressure at separator are fixed, the resulting total pressure drop of the lifting system will be the sum of hydrostatic, acceleration and frictional component.

Lifting equation arrives from Bernoulli's fundamentals of conservation of energy and represented in the differential form:

$$\frac{dP}{dL} = \frac{g}{g_c} \rho \sin\theta + \frac{\rho v dv}{g_c dL} + \frac{f \rho v^2}{2 g_c D} \quad (19)$$

The graph of lifting equation is a parabola, which properties will depend on reservoir fluid behavior inside production tubing. Hydrostatic component corresponds to the

intersection with the y-axis, acceleration component corresponds to the shift along the x-axis and frictional component corresponds to the degree of parabolic compression.

In terms of costs optimization it is very important to define production cases, in which well performance will be controlled by inflow from reservoir or will be restricted by the size of production tubing. If reservoir can provide a wellbore with high inflow capacity, running production tubing with too big diameter will result in temporary high production rate at surface. Because tubing diameter is too big, at later stage of production total pressure drop will not be sufficient to provide with continuously high production rate. Well performance will decrease and in this case, it is believed that a long-term production is sacrificed for a temporary high oil return

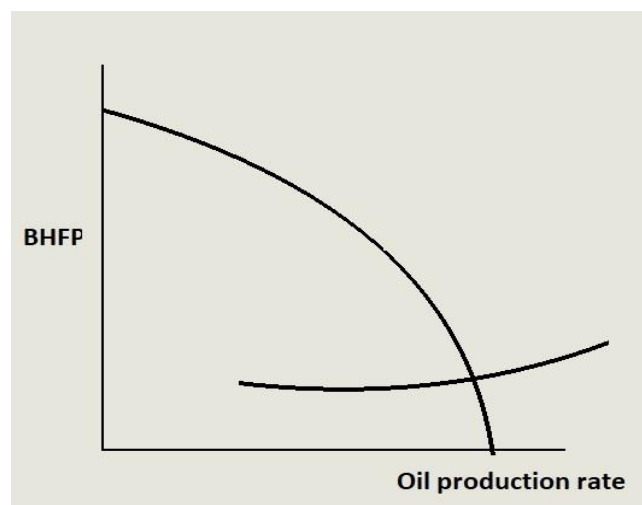

Figure 10: Production case: big tubing diameter

Another example, when size of production tubing is too small. In this case, observing low oil production rate at surface, whereas reservoir can provide a wellbore with high inflow capacity, companies may believe that well performance suffers because of weak formation. The result can be waste of dollars on unnecessary reservoir stimulation technique.

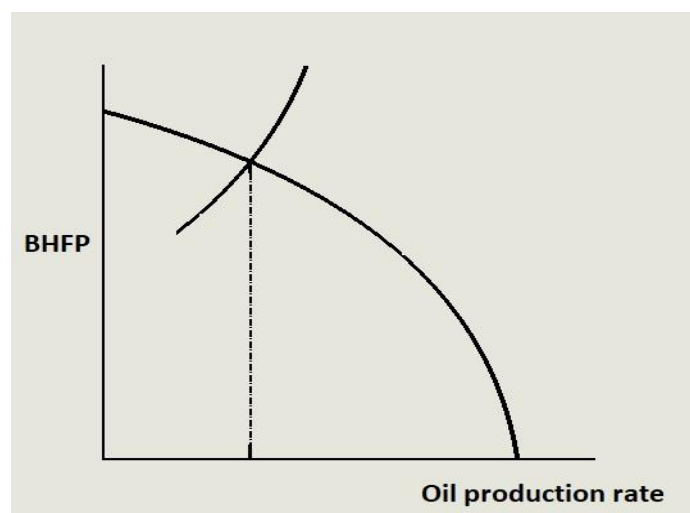

Figure 11: Production case: small tubing diameter

Last example, when reservoir inflow performance is low. Even if optimal size of production tubing is selected, there will be a low oil production rate at surface, which can indicate on necessity to perform reservoir stimulation technique. Changing size of production tubing will not greatly affect well performance. In this case, it is believed that well performance is constrained by inflow from the reservoir.

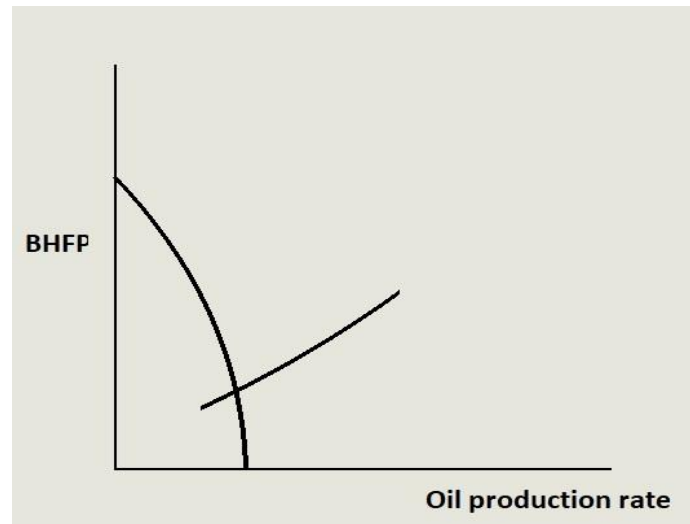

Figure 12: Production case: weak formation

Finally, to estimate oil production rate at surface of one single well, reservoir inflow relation and outflow tubing relation are combined together on the same plot. The intersection point of two curves is the solution for well deliverability.

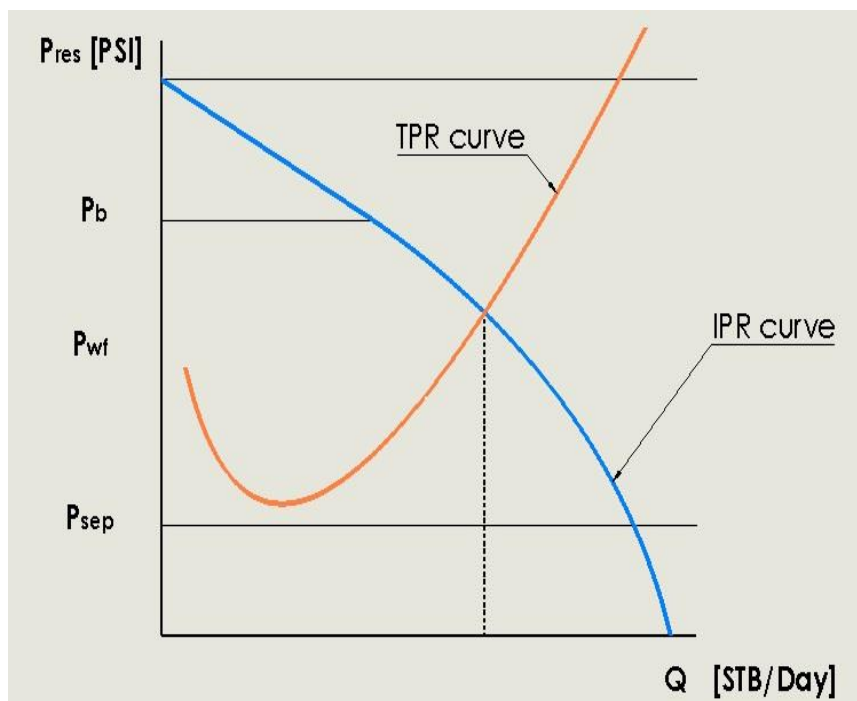

Figure 13: Solution for well deliverability



## Part 3. Optimization Model



### 3.1 Modelling total construction costs

Multilateral well that include two horizontal sections attached to the mother bore will be referred to as dual lateral. Three laterals and four laterals attached will be referred correspondingly to as triple lateral and quad lateral well.

Assume total construction costs of a single horizontal well will be equal to 1C. Then, if one more single well will be completed, total costs of field development will be equal to 2C and will be 100% costs.

To observe advantage of multilateral type of field development variable of total construction costs  $x$  and production rate  $y$  will be estimated.

Table 4: Optimization criteria

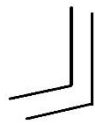
Single horizontal	Dual lateral	Two single horizontals
		
Total construction costs $C = 1$	Total construction costs $C = x$	Total construction costs $C = 2$
Production rate $Q = 1$	Production rate $Q = y$	Production rate $Q = 2$

Supposedly, if horizontal section of a single well is identical to each horizontal section of dual lateral, then  $x$  of dual lateral will be more than 1C of single horizontal, but cannot exceed 2C of two single wells. Considering this, first optimization criteria can be established:

$$1C < x \leq 2C \tag{20}$$

Let total construction costs of a single horizontal well be a sum of total costs to construct a vertical section and total costs to construct a horizontal section:

$$C = v + h \quad (21)$$

For a multilateral well  $x$  will depend on number of laterals added to the mother bore, which will correspond to variable  $n$ . Considering this, relation of total costs of a multilateral well can be established:

$$C = v + n * h \quad (22)$$

Total costs of field development by a number of single wells will be a hundred percent costs and equal to:

$$2C = 2(v + h) = 100\% \quad (23)$$

In oil industry, construction of a horizontal bore is technically more difficult than construction of a vertical bore and can include expensive completion equipment to support oil inflow into the well. Inflow capacity of a horizontal well depends on reservoir properties and well length. In tight reservoirs, it is expected that extended length will improve oil inflow; however, in case of high fluid mobility long extension can have little influence on total well performance. In order to categorize the length of a horizontal section with respect to the reservoir block, term *reservoir exposure* is introduced in the thesis.

If costs to complete one meter of horizontal section more than costs to complete one meter of vertical section, let category of Low-level reservoir exposure will correspond to relation:

$$h = 0.5v$$

which implies that length of the horizontal section substantially less than height of the vertical section. Then for this case, ratio of equation (22) to (23) can be estimated:

- Dual lateral, n=2:

$$\frac{v + 2 * 0.5v}{2 (v + 0.5v)} = \frac{2v}{3v} = 0.66$$

- Triple Lateral, n=3:

$$\frac{v + 3 * 0.5v}{2 (v + 0.5v)} = \frac{2.5v}{3v} = 0.83$$

- Quad Lateral, n=4:

$$\frac{v + 4 * 0.5v}{2(v + 0.5v)} = \frac{3v}{3v} = 1$$

Let category of Medium-level reservoir exposure will correspond to relation:

$$h = v$$

which implies that length of the horizontal section relatively less than height of the vertical section. Then for this case, ratio of (22) to (23) can be estimated:

- Dual lateral, n=2:

$$\frac{v + 2 * v}{2 (v + v)} = \frac{3v}{4v} = 0.75$$

- Triple Lateral, n=3:

$$\frac{v + 3 * v}{2 (v + v)} = \frac{4v}{4v} = 1$$

- Quad Lateral, n=4:

$$\frac{v+4*v}{2(v+v)} = \frac{5v}{4v} = 1.25$$

Let category of High-level reservoir exposure will correspond to relation:

$$h = 1.5v$$

which implies that length of the horizontal section of the well more than height of the vertical section. Then for this case, ratio of (22) to (23) can be estimated:

- Dual lateral, n=2:

$$\frac{v + 2 * 1.5v}{2 (v + 1.5v)} = \frac{4v}{5v} = 0.8$$

- Triple Lateral, n=3:

$$\frac{v + 3 * 1.5v}{2 (v + 1.5v)} = \frac{5.5v}{5v} = 1.1$$

- Quad Lateral, n=4:

$$\frac{v + 4 * 1.5v}{2(v + 1.5v)} = \frac{7v}{5v} = 1.4$$

Ratio of total well construction costs of multilateral to two single wells combined in the table:

Table 5: Ratio of total construction costs

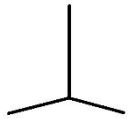
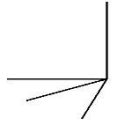
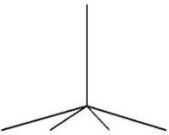
Multilateral type		Reservoir exposure		
		Low level h=0.5v	Medium level h=v	High level h=1.5v
Dual		0.66	0.75	0.8
Triple		0.83	1	1.1
Quad		1	1.25	1.4

Based on the ratios, optimization criteria is represented as limits of variable  $x$ :

- Dual lateral,  $n=2$ :

$$1.32C \leq x \leq 1.6C$$

- Triple Lateral,  $n=3$ :

$$1.66C \leq x \leq 2.2C$$

- Quad Lateral,  $n=4$ :

$$2C \leq x \leq 2.8C$$

It is observed that to complete an oil field with dual lateral well will cost 33% less than completions with two single horizontals.

To complete an oil field with triple lateral will cost 17% less than completion with two single horizontals.

To complete an oil field with quad lateral will cost approximately same as to complete a field with two single horizontals.

Corresponding savings can be calculated for every category of reservoir exposure by using the relation:

$$\left(1 - \frac{v+n*h}{2*(v+h)}\right) * 100\% \quad (24)$$

Table 6: Savings percentage of Multilateral type compared to two single wells.

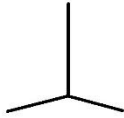
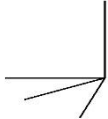
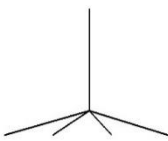
Field completion type		Reservoir exposure		
		Low level h=0.5v	Medium level h=v	High level h=1.5v
Dual		33%	25%	20%
Triple		17%	0%	-10%
Quad		0%	-25%	-40%

### 3.2 Modelling well performance

Analysis of multilateral performance based on comparison of dual lateral with two single horizontal wells.

Using theory defined in Part 2 modelling begins with flow calculations for single horizontal well. It is expected that dual lateral cannot yield more flow rate at surface than two single wells due to pressure drop at junction. Mother bore of dual lateral will receive friction from each lateral section (see fig.20).

Considering this, optimization criteria for oil production rate of a multilateral well can be established:

$$1Q < y \leq 2Q \quad (25)$$

To understand expected value of loss in flow rate, in the book H. Dale Beggs has provided with the useful information about losses in each component of equation (19).

Table 7: Well flow correlations (Beggs, 2003)

Component	Oil Wells	Gas Wells
Hydrostatic	70 – 90	20 – 50
Friction	10 – 30	30 – 60
Acceleration	0 – 10	0 – 10

#### 3.2.1 Assumptions

- 1) Isotropic reservoir
- 2) Undersaturated oil
- 3) One lateral drains single ellipsoid
- 4) Acceleration component disregarded
- 5) Double friction at junction

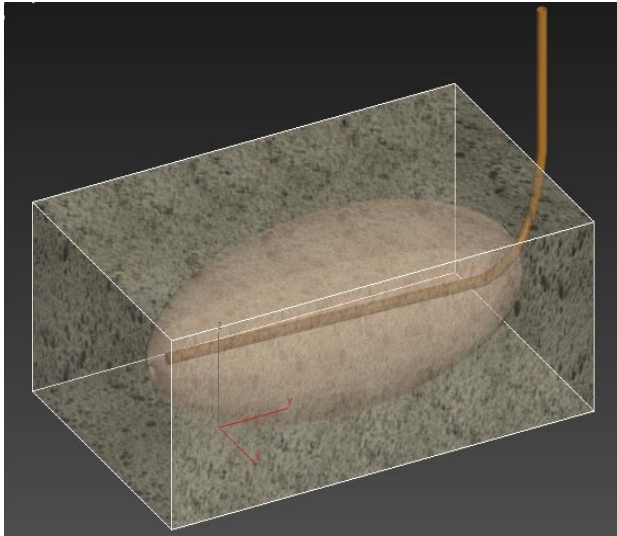

Figure 14: 3d modelling case: Single Well

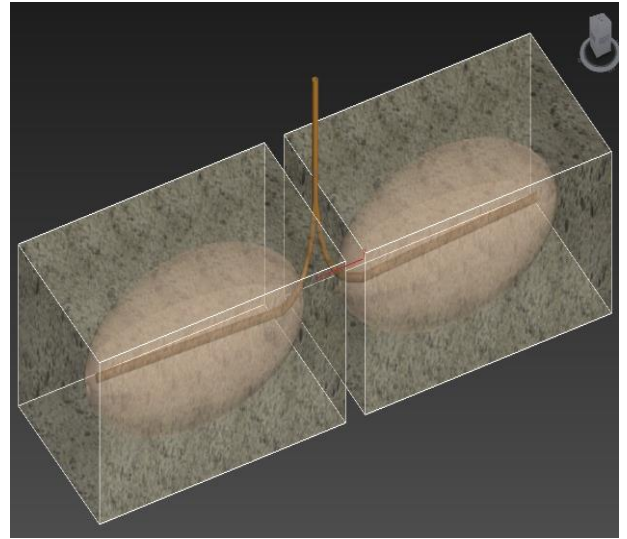

Figure 15: 3d modelling case: Dual lateral well

Both figures converted into 2D case:

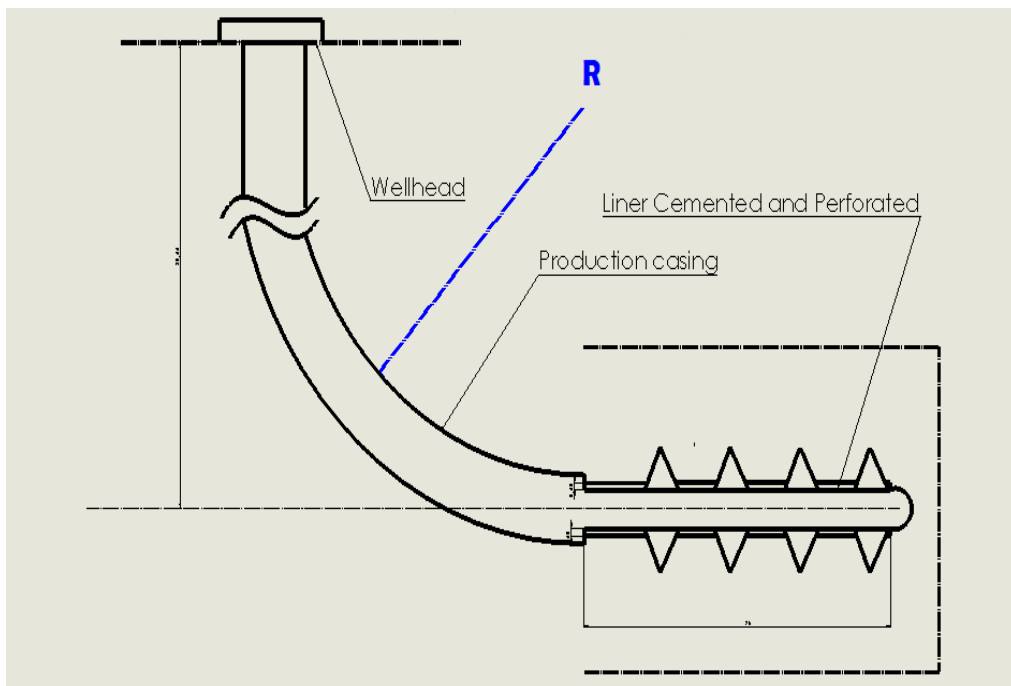

Figure 16: 2d modelling case



### 3.2.2 Inputs and constants

The first task is to find solutions for the length of the horizontal section according to the list of constants and the list of inputs:

Table 8: List of constant parameters used for modelling in Matlab

<b>Parameter</b>	<b>Symbol</b>	<b>Unit of measurement</b>
Permeability	k	[miliDarcy]
Reservoir height	h	[meter]
Drainage boundary	Re	[meter]
Fluid viscosity	Myl	[Pascal * second]
Kinematic viscosity	Nyg	[Pascal * second]
Fluid density	Rol	[kg / m <sup>3</sup> ]
Gas density at standard	Rog0	[kg / m <sup>3</sup> ]
Formation volume factor	B	-
Wellbore radius	Rw	[meter]
Bubble pressure	Pb	[bar]

Table 9: List of input parameters used for modeling in Matlab

<b>Parameter</b>	<b>Symbol</b>	<b>Unit of measurement</b>
Reservoir pressure	Pres	[bar]
Well length	L	[bar]
Wellhead pressure	WHP	[bar]

Boundary for reservoir pressure does not exceed 344 bar. Boundary for well length set according to Joshi's criteria (see). For turbulent flow, Blasius form of friction factor was used:

$$f = 0.046Reyn^{-0.2} \quad (26)$$

### 3.2.3 Calculating by iterations

Horizontal well can be represented as the combination of three components: height of the vertical section H, turning radius R and the length of the horizontal section L. Turning radius R creates an angle, which complicate flow calculations. To neglect the influence of turning radius horizontal and lateral wells have been discretized in matlab with application of position vector  $j$  and pressure vector  $i$ .

$$|\vec{i}| = |\vec{j}|, \text{ where } j \in [1, x)$$

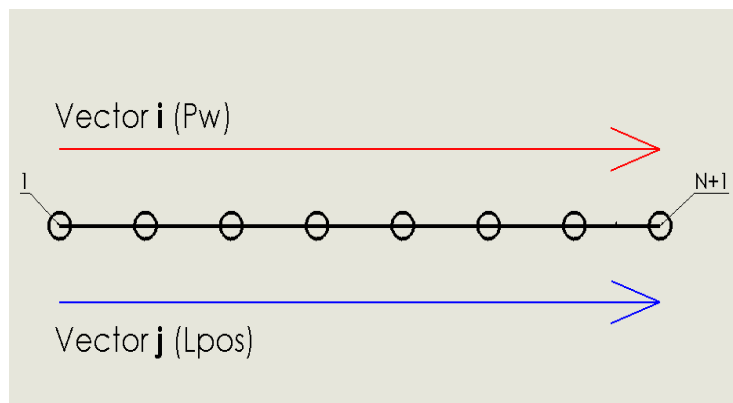

Figure 17: Applying vectors to fill pressure and position along the well

To implement iteration process with application of vectors, 2d modelling picture is reestablished:

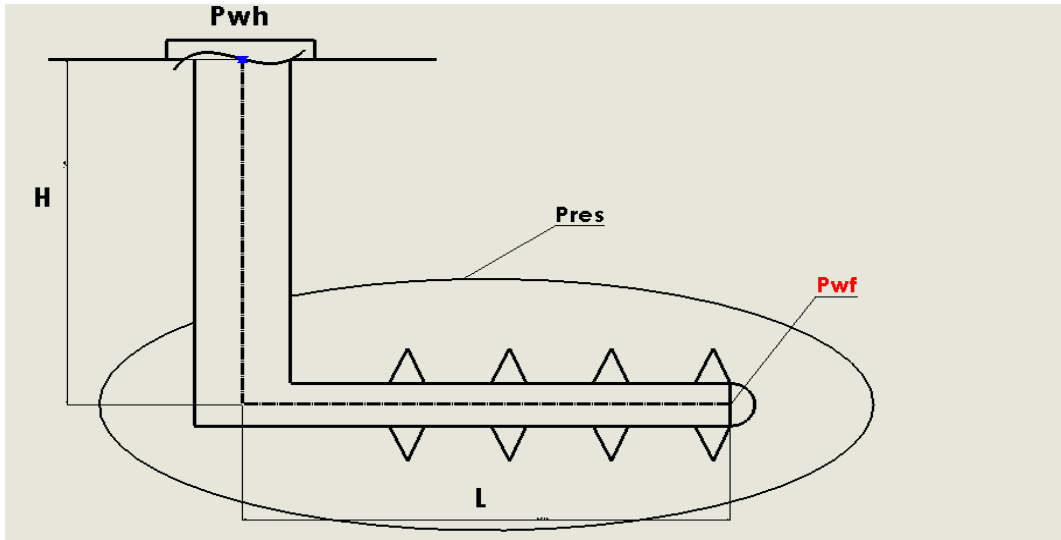

Figure 18: Simplified picture of the modelling case in Matlab

The next step was to divide the well by a number of nodes and implement equations (14), (19) by iteration, guessing the value of the bottom hole flowing pressure.

Iterative process to find bottom-hole flowing pressure starts with the guess value at the toe of the well. Then, computer performs calculation by subtracting pressure drop at every consecutive node. If calculated pressure at the last note N+1 does not coincide with the accuracy, then computer returns at the first node and repeats the calculation automatically decreasing guess value at the toe.

Logical loop of iterations have the following form:

$$\text{While } \left| \frac{P_w(N+1) - WHP}{WHP} \right| > \text{accuracy}$$

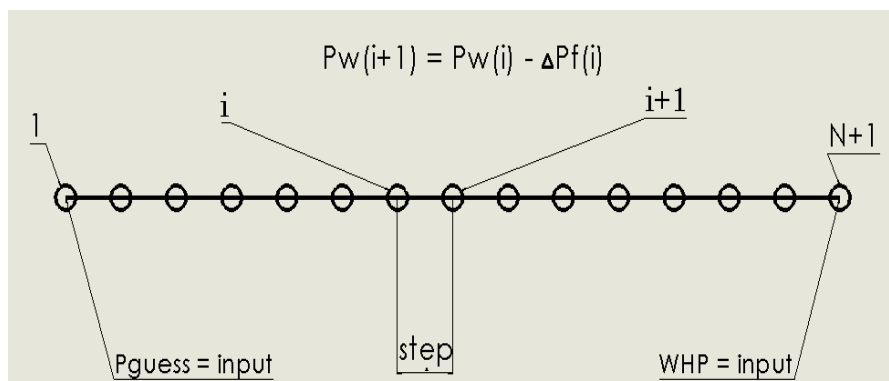

Figure 19: Calculation of the pressure drop in horizontal well

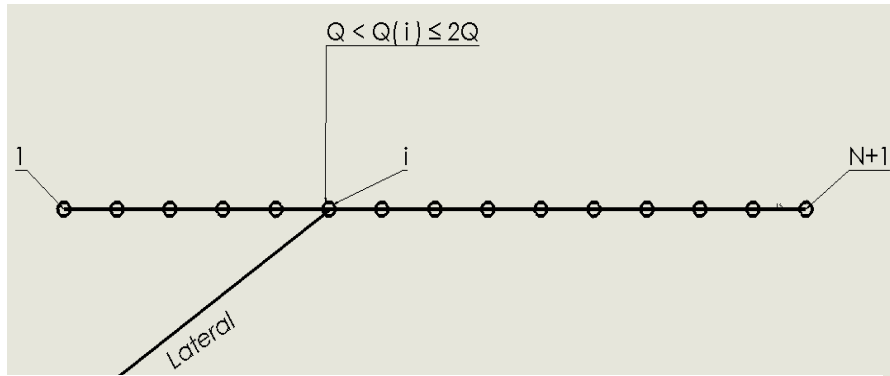

Figure 20: Dual lateral well. Calculation of the pressure drop in each node

### 3.2.4 List of solutions

$k=100$  [mD]

Reservoir pressure  $P_{res}= 240$  [bar]

Wellhead pressure  $WHP = 40$  [bar]

Bubble pressure = 220 [bar]

Table 10: List of solutions obtained in Matlab

Parameter	Symbol	Unit of measurement
Height of the mother bore	2400	[m]
Well length	600	[m]
Bottom hole flowing pressure	211	[bar]
Joshi's steady state productivity index	10	[STB/Day – PSI]
GOR	0.49	[Pascal * second]
Perforated interval	120, 240, 460, 480	[kg / m <sup>3</sup> ]
Gas density at standard	Rog0	[kg / m <sup>3</sup> ]

Formation volume factor	B	-
Flow rate at boiling point	3404	[STB/Day – PSI]
Absolute Open Flow	19789	[bar]

After bottom hole flowing pressure has been found, Vogel's relation of inflow performance (15) was used to obtain IPR curve.

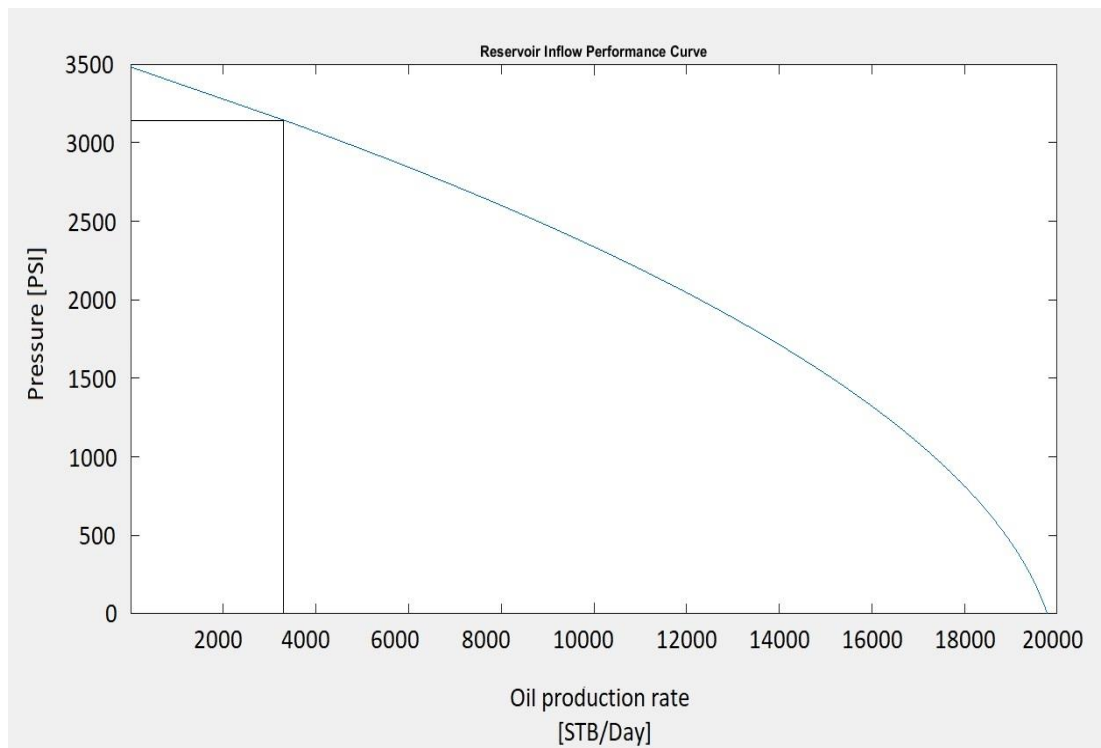

Figure 21: Inflow performance of the reservoir model (figure from Matlab)

### 3.3 Outflow performance

#### 3.3.1 Low fluid mobility

Inflow performance with medium fluid mobility has been simulated, which corresponds to permeability value  $k = 100$  [mD] and AOF 20000 [STB/Day].

First, production tubing 5.5", 20 lbs/ft, 4.778" ID were tested at boiling point, which resulted in 11990 [STB/Day] for single horizontal and 10600 [STB/Day] for half of dual lateral:

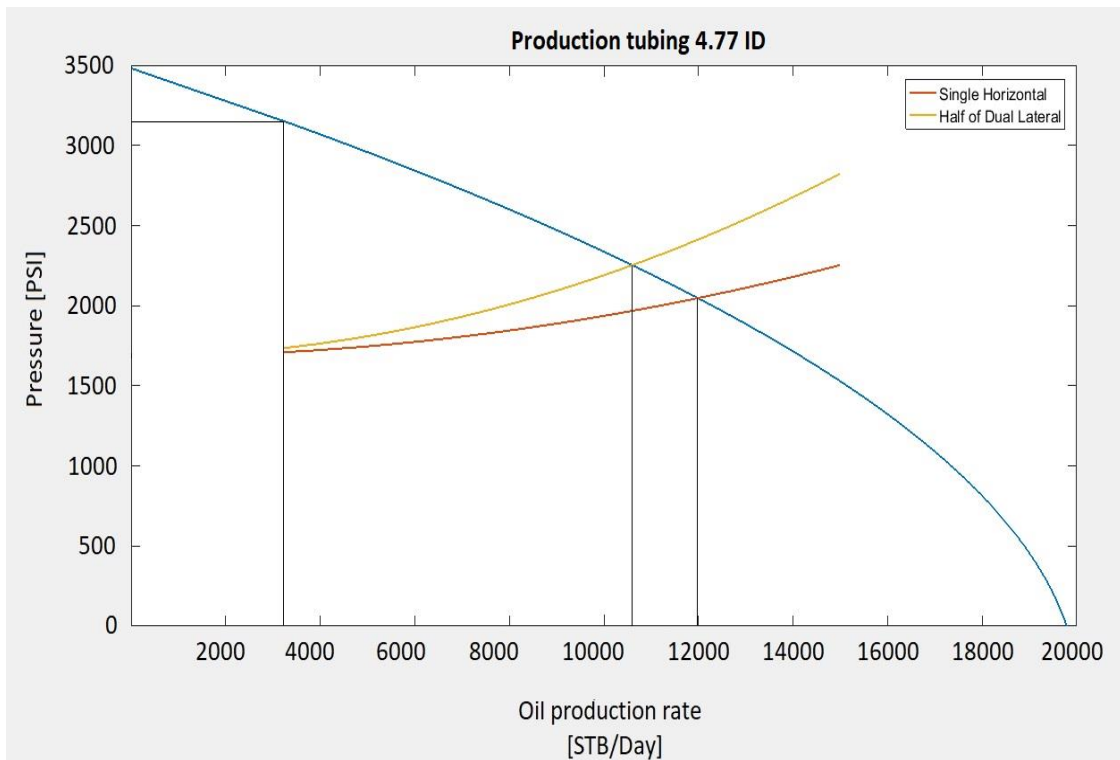

Figure 22: Production performance: 4.77'' ID,  $k=100$  [mD] (figure from Matlab)

Estimating ratio of production performance:

- Half of dual lateral well:

$$\frac{10600 \text{ [STB/Day]}}{11990 \text{ [STB/Day]}} = 0.88$$

12% loss of lateral performance with respect to two single wells.

To reduce loss in oil production rate tubing size has been increased to 7", 29 lbs/ft, 6.184" ID and tested at boiling point. For single horizontal well oil production rate has become 12550 [STB/Day] and for half of dual lateral: 11390 [STB/Day]:

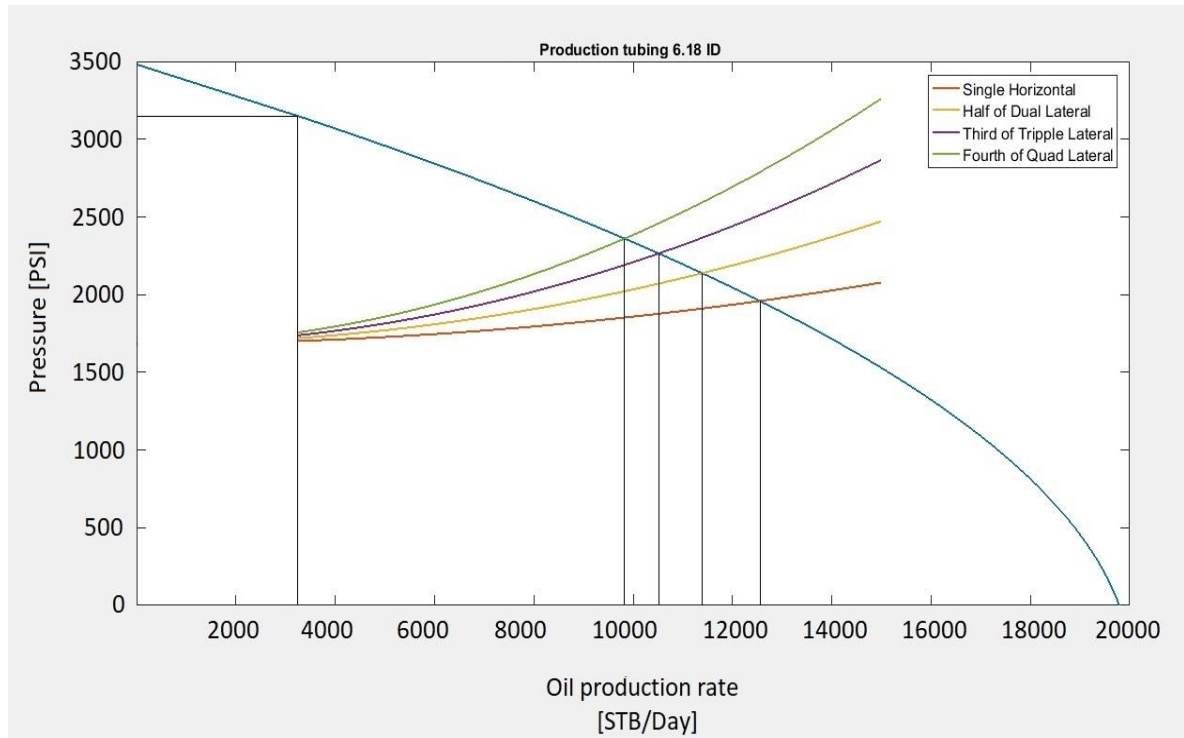

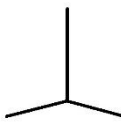
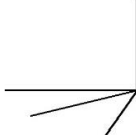
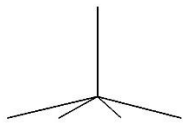

Figure 23: Production performance: 6.18"ID, k=100 [mD] (figure from Matlab)

Table 11: Results from simulation. Case 1: Low Fluid Mobility

Oil production rate [STB day]			
k=100 [mD], Production tubing 7"			
Single Well	Dual lateral	Tripple lateral	Quad lateral
			
12550	y	y	y
	Half of Dual lateral 11390	Third of Tripple lateral 10520	Fourth of Quad lateral 9825

Estimating ratio of well performance:

- Half of dual lateral / Single well:

$$\frac{11390 \text{ [STB/Day]}}{12550 \text{ [STB/Day]}} = 0.9$$

- Third of triple lateral / Single well:

$$\frac{10520 \text{ [STB/Day]}}{12550 \text{ [STB/Day]}} = 0.83$$

- Fourth of quad lateral / Single well:

$$\frac{9825 \text{ [STB/Day]}}{12550 \text{ [STB/Day]}} = 0.78$$

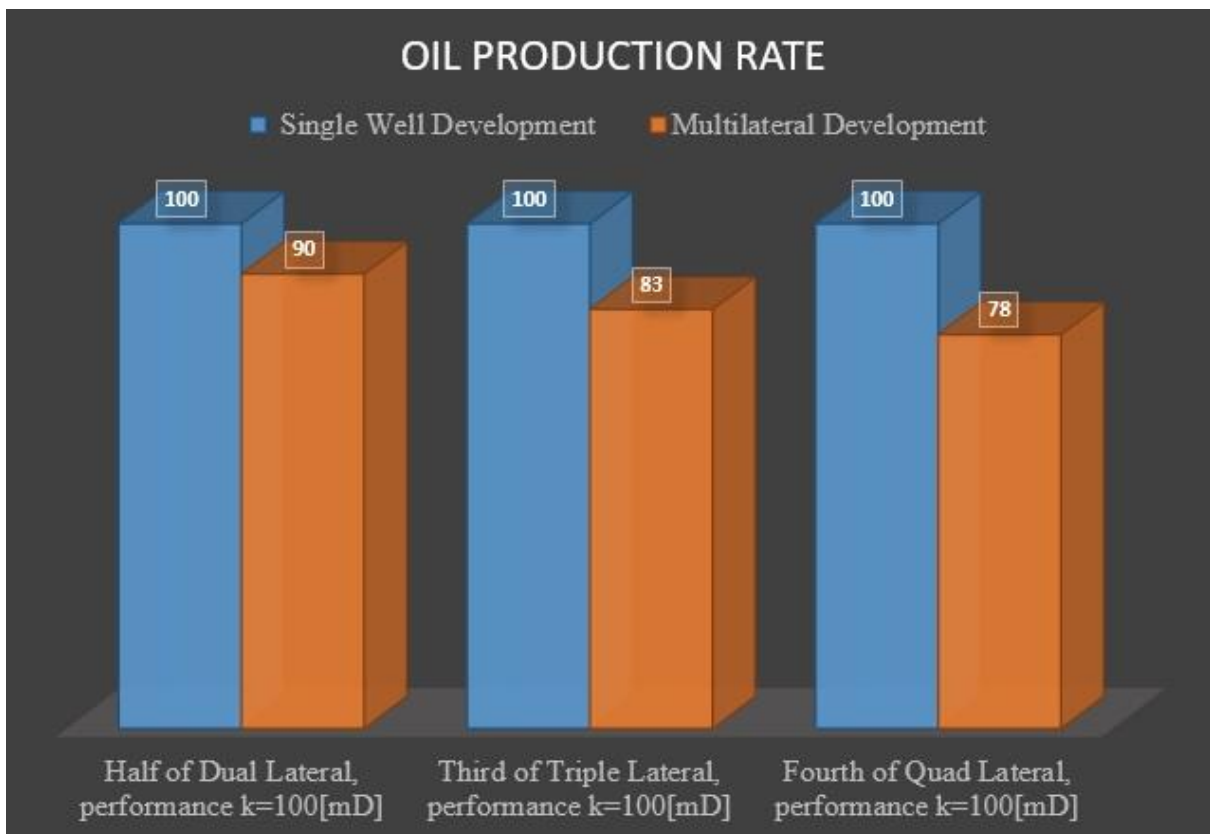

Figure 24: Comparative chart. Production rate performance. Case 1: Low Fluid Mobility

Observation: Minimum 10% loss of lateral performance in reservoir with low fluid mobility.



### 3.3.2 High fluid mobility

Inflow performance of high fluid mobility case has been simulated which corresponds to  $k = 500$  [mD] AOF 100000 [STB/Day]. In this case, it is expected that fluid flow velocity will raise and gas will start to come out of oil faster, increasing friction at junction.

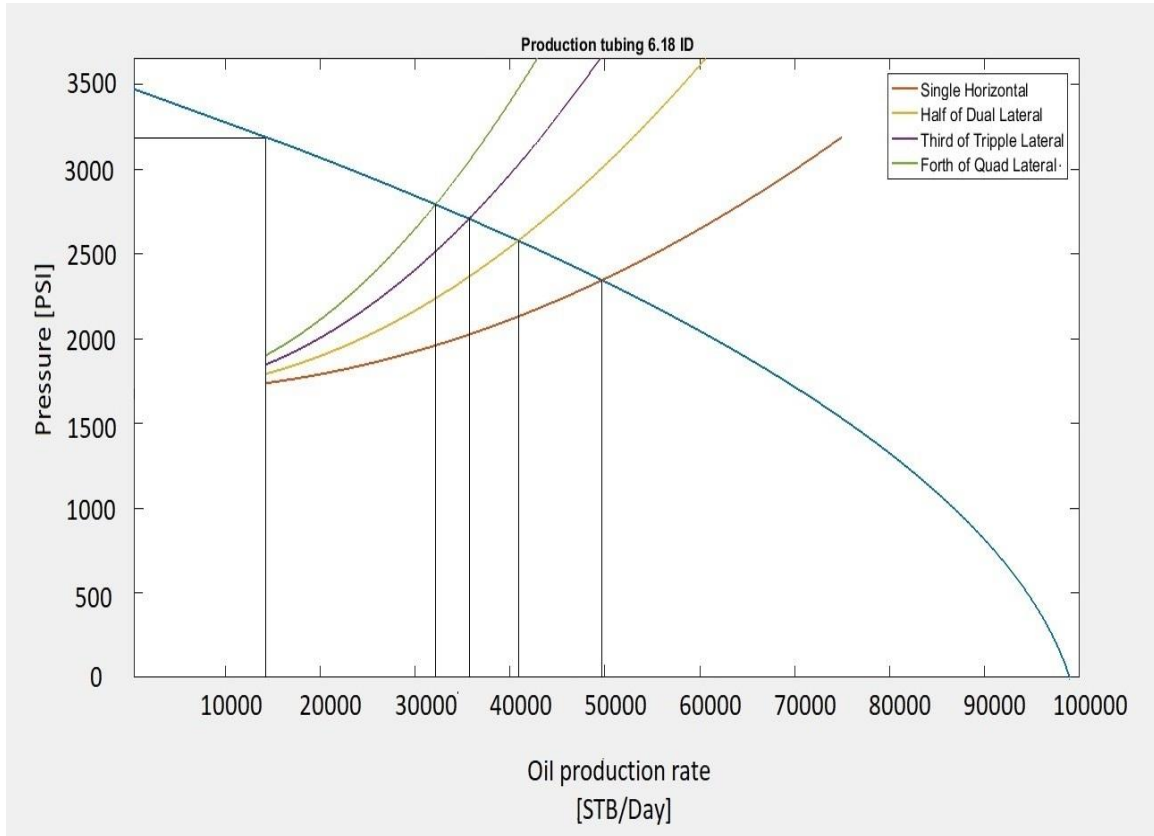
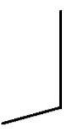
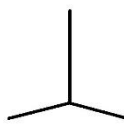
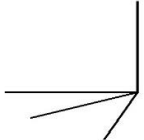
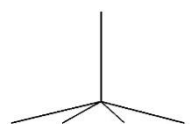

Figure 25: Production performance: 6.18"ID,  $k=500$  [mD] (figure from Matlab)

Table 12: Results from simulation. Case 2: High Fluid Mobility

Oil production rate [STB day]			
$k=500$ [mD], Production tubing 7"			
Single well	Dual lateral	Tripple lateral	Quad lateral
			
49610	y	y	y
	Half of Dual well 40870	Third of Tripple well 35965	Fourth of Quad well 32090

Ratio of well performance:

- Half of dual lateral / single well:

$$\frac{40870 \text{ [STB/Day]}}{49610 \text{ [STB/Day]}} = 0.82$$

- Third of triple lateral / single well:

$$\frac{35965 \text{ [STB/Day]}}{49610 \text{ [STB/Day]}} = 0.72$$

- Fourth of quad lateral / single well:

$$\frac{32090 \text{ [STB/Day]}}{49610 \text{ [STB/Day]}} = 0.64$$

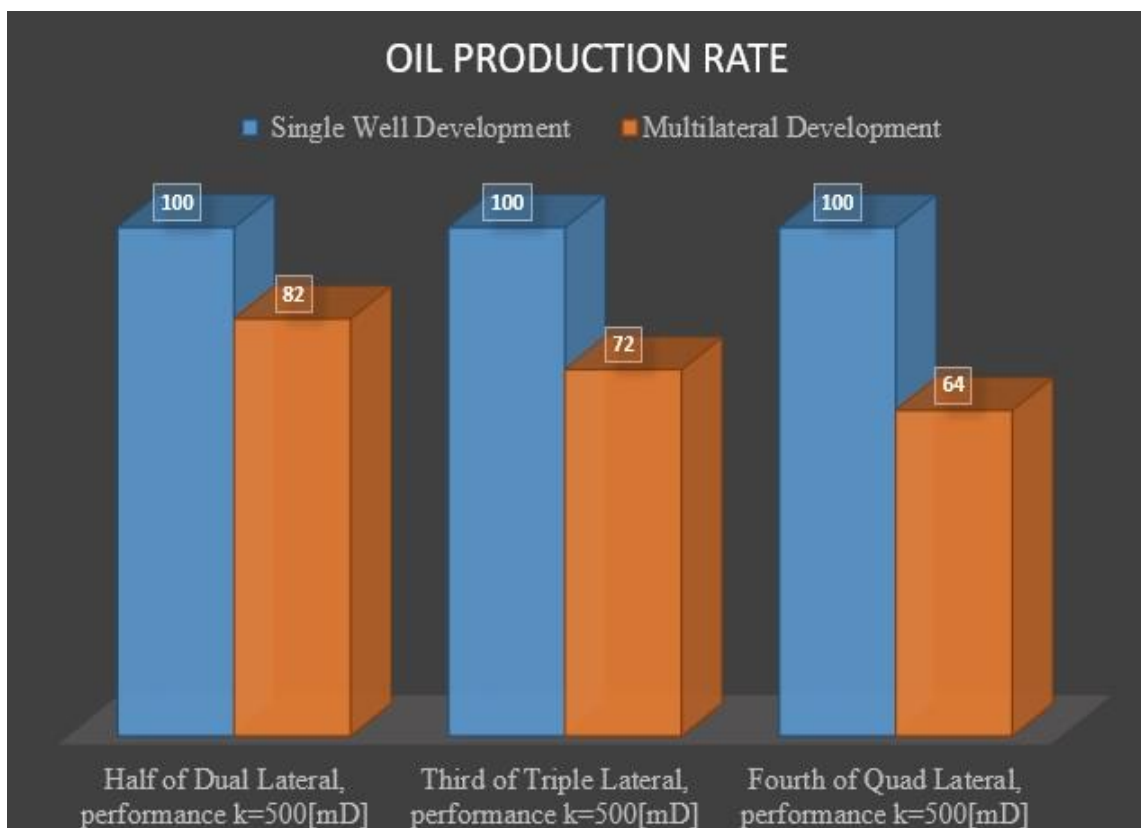

Figure 26: Comparative chart. Production rate performance. Case 2: High Fluid Mobility

Observation: Minimum 18% loss of lateral performance in reservoir with high fluid mobility.

### 3.3.3 Very high fluid mobility

Reservoir with very high fluid mobility has been simulated which corresponds to permeability value  $k = 1000$  [mD] and AOF 200000 [STB/Day]. It is expected that in such formations a multilateral well will experience high frictional pressure drop.

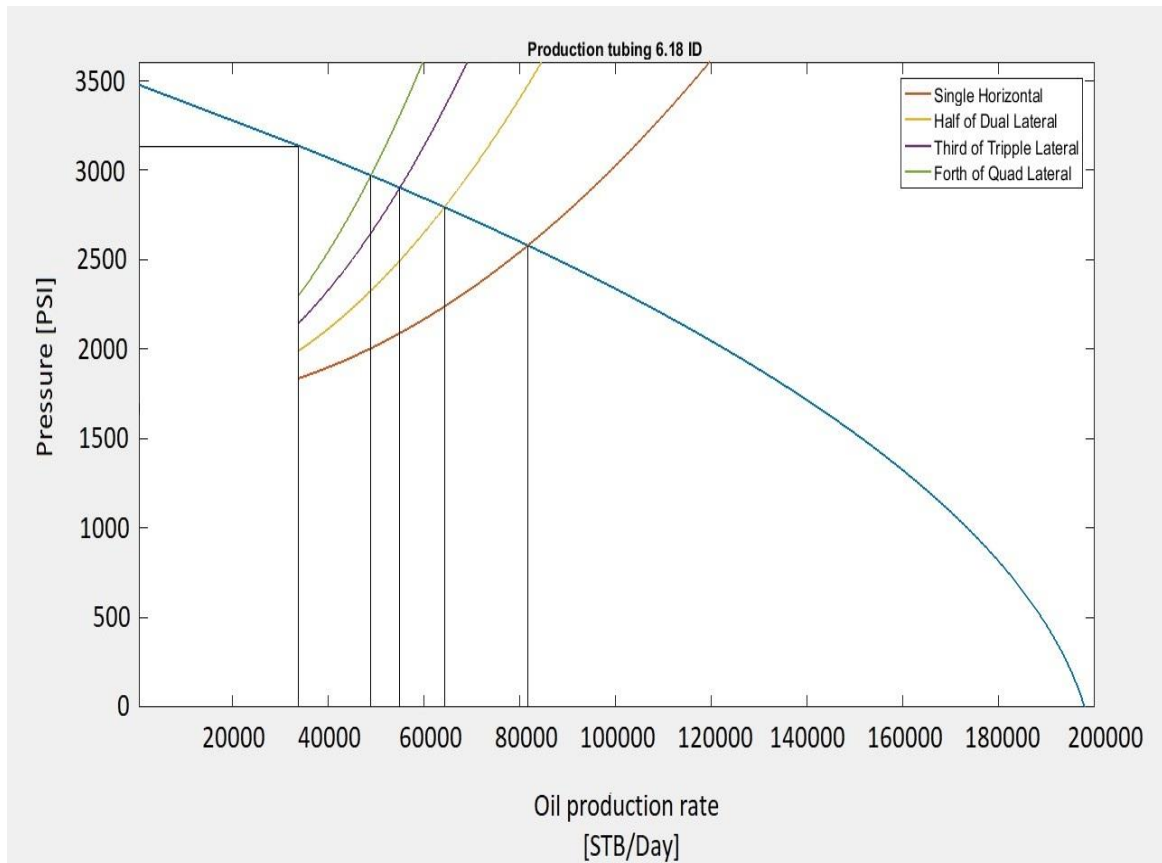

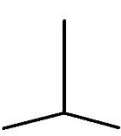
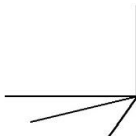
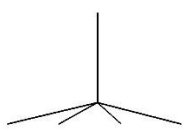

Figure 27: Production performance: 6.18"ID,  $k=1000$  [mD] (figure from Matlab)

Table 13: Results from simulation. Case 3: Very high fluid mobility

Oil production rate [STB day]			
$k=1000$ [mD], Production tubing 7"			
Single well	Dual lateral	Tripple lateral	Quad lateral
			
81730	y	y	y
	Half of Dual well 64330	Third of Triple well 55025	Fourth of Quad well 48990

Ratio of well performance:

- Half of dual lateral well / single well:

$$\frac{64330 \text{ [STB/Day]}}{81730 \text{ [STB/Day]}} = 0.78$$

- Third of triple lateral well / single well:

$$\frac{55025 \text{ [STB/Day]}}{81730 \text{ [STB/Day]}} = 0.67$$

- Fourth of quad lateral well / single well:

$$\frac{48990 \text{ [STB/Day]}}{81730 \text{ [STB/Day]}} = 0.6$$

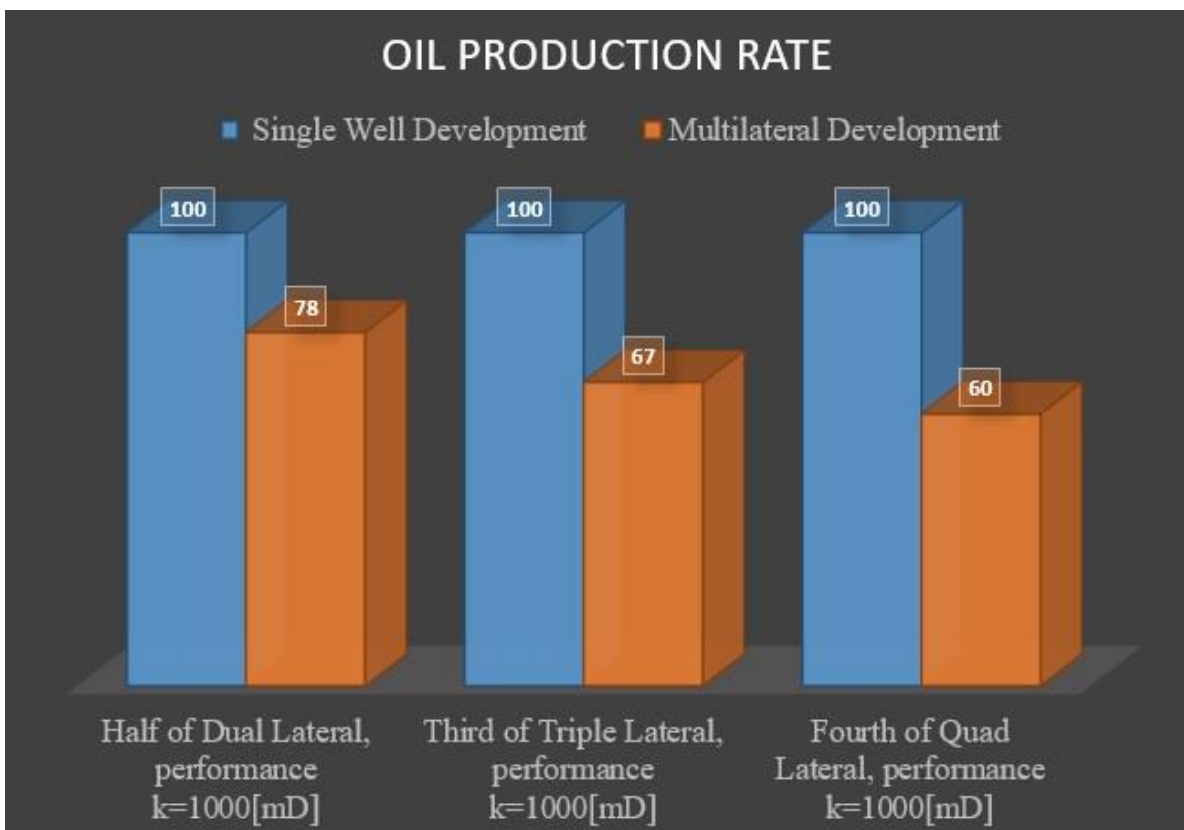

Figure 28: Comparative chart. Production rate performance. Case 3: Very High Fluid Mobility

Observation: Minimum 22% loss of lateral performance in reservoir with very high fluid mobility.

### 3.4 Optimization example

Using defined reservoir model  $k = 100$  [mD],  $AOF = 20000$  [STB/Day] the task is to optimize an offshore field with application of multilateral wells. Assume total construction costs of a single horizontal well will be approximately 35000 (1000USD) and price per barrel of oil 70 (USD). From simulation the result of oil production rate of single well is 12550 (STB/Day). The task is to compare resulting savings in case if Dual lateral well selected instead of two single horizontals.

Solution:

Using the chart of estimated ratios of oil production rate in reservoirs with low fluid mobility (fig.24), 10% loss of performance is observed in dual lateral type of development. Check this case.

1). Total construction costs

- Two single wells:  $2 \times 35000$  (1000USD) = 75000 (1000 USD)

For dual lateral limits of construction costs  $x$  have been estimated (p.22). Applying ratio factor equal to 1.33

- Dual Lateral well:  $1.33 \times 35000$  (1000USD) = 46550 (1000 USD)

2). Well performance

- Two single wells:  $2 \times 12550$ (STB/Day) = 25100(STB/Day)

- Dual lateral well:  $0.9 \times 2 \times 12550 = 22590$  (STB/Day)

3). Revenue

- Two single wells:  $70$  (USD) $\times 25100$ (STB/Day) = 1757 (1000USD/Day)

- Dual lateral well:  $70$  (USD) $\times 22590$ (STB/Day) = 1581 (1000USD/Day)

Next estimation is a pay-off period, which is the ratio of total construction costs of the well to its revenue a day.

4). Pay-off:

- Two single wells:  $\frac{75000 (1000\text{USD})}{1757 (1000\text{USD}/\text{Day})} = 43 \text{ days}$
- Dual lateral well:  $\frac{46550 (1000\text{USD})}{1581 (1000\text{USD}/\text{Day})} = 29 \text{ days}$

Corresponding savings will be the difference between pay-off of two well types divided by total construction costs of two single wells:

$$\frac{(43-29)*1581(1000\text{USD}/\text{Day})}{75000(1000\text{USD})} * 100\% = \frac{22134 (1000\text{USD})}{75000 (1000\text{USD})} * 100\% = \underline{29.5\%}$$

The concept of costs per barrel of oil extracted is introduced as the ratio of total construction costs to revenue of the well after one day of oil production.

5). Costs per barrel extracted

- Two single wells:  $\frac{75000(1000\text{USD})}{1757(1000\text{USD})} = 46.68$
- Dual lateral:  $\frac{46550(1000\text{USD})}{1581(1000\text{USD})} = 29.44$

Decrease in costs per barrel extracted for Dual lateral well will be:

$$1 - \frac{29.44}{46.68} = 37\%$$

The concept of revenue rate is introduced in the thesis. It will be the ratio of well revenue to its total construction costs.

6). Revenue rate

- Two single wells:  $\frac{1757(1000\text{USD})}{75000(1000\text{USD})} * 100\% = 2.3\%$

- Dual latera well:  $\frac{1581(1000\text{USD})}{46550(1000\text{USD})} * 100\% = 3.4\%$

Revenue efficiency of Dual lateral with respect to two single wells can be estimated by observing ratio:

$$\frac{3.4\%}{2.3\%} * 100\% = 147.8\%$$

For the given optimization example, result are represented on the chart

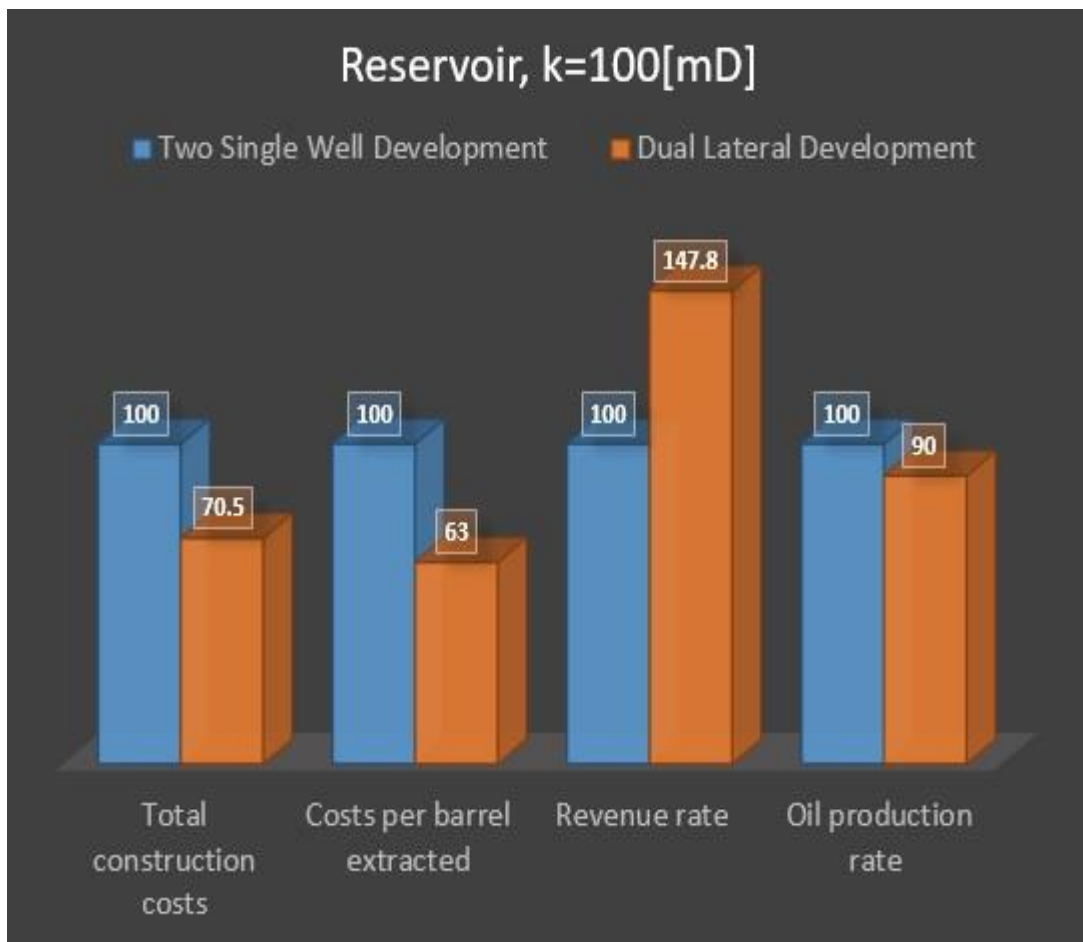

Figure 29: Comparative chart of Dual lateral performance. Optimization example

## Results and discussions

Based on optimization criteria (20) and (25) limits of variable  $y$  and variable  $x$  estimated and presented in the table:

Table 14: Limits of production performance  $y$  and total construction costs  $x$

Type of Multilateral	Well performance	Total construction costs
Dual lateral	$1.56Q \leq y \leq 1.8Q$	$1.32C \leq x \leq 1.6C$
Triple lateral	$2Q \leq y \leq 2.5Q$	$1.66C \leq x \leq 2.2C$
Quad lateral	$2.4Q \leq y \leq 3.12Q$	$2C \leq x \leq 2.8C$

Multilateral wells are very efficient in reservoirs characterized with low permeability or tight fluids. Approximate loss of oil production rate in case of one lateral added to single horizontal will be:

$$\left(1 - \frac{1.8Q}{2Q}\right) * 100\% = 10\%$$

In case of very high fluid mobility, friction of fluid will increase, which will result in loss of oil production rate compared to two single wells:

$$\left(1 - \frac{1.56Q}{2Q}\right) * 100\% = 22\%$$

Total construction costs of dual lateral well will be at least 33% less than total construction costs of two single horizontal wells:

$$\left(1 - \frac{1.32C}{2C}\right) * 100\% = 33\%$$

In case of extended reach wells total construction costs of dual lateral will be 20% less than total construction costs of two single horizontal wells:

$$\left(1 - \frac{1.6C}{2C}\right) * 100\% = 20\%$$

However, in case of increased permeability or high fluid velocity, oil production performance of multilateral wells reduces compared to two single horizontal wells. Such reservoirs require exclusive design of a multilateral well to bring profitability for an oil company.



## References

- 1).A.D. Hill, D. Z. (2007). In W. R. Landrum, *Multilateral Wells* (p. 191). Society of Petroleum Engineers .
- 2).Ali. A. Garrouch, H. M. (2005). A web-based expert system for the planning and completion of multilateral wells. *Journal of Petroleum Science and Engineering*, 20.
- 3). Beggs, H. (2003). *Production optimization:using Nodal Analysis*. Tulsa, Okla: OGCI and Petroskills publ.
- 4). Elyasi, S. (2016, March 2016). Assessment and evaluation of degree of multilateral well's performance for determination of their role in oil recovery at a fractured reservoir in Iran. *Egyptian Journal of Petroleum*, 1-14. Retrieved from <https://www.sciencedirect.com/science/article/pii/S1110062115000902>
- 5). Flatern, R. V. (2016). Multilateral Wells. *The Defining Series*, 2.
- 6). Holm, G. (1998). How abnormal pressures affect hydrocarbon exploration, exploitation. *Oil&Gas Journal*.
- 7). Joshi, S. D. (1991). *Horizontal Well Technology*. Tulsa: PennWell Books.

8).M.J.Roberts, A.Kirkwood, & J.Bedford. (1998). Real-Time Geosteering in the Tern Field

for Optimum Multilateral Well Placement . *European Petroleum Conference* (p. 8).

Hague: Society of Petroleum Engineers.

9). Sada.D.Joshi. (October 5-8, 1986). Augmentation of Well Productivity with Slant and

Horizontal Wells. *SPE 15375* (p. 13). New Orleans: Journal of Petroleum Technology.

10). Stalder, J. L., York, G. D., & al., e. (2001). Multilateral-Horizontal Wells Increase Rate

and Lower Cost Per Barrel in the Zuata Field, Faja, Venezuela. *Society of Petroleum*

*Engineers* (p. 9). Porlamar: SPE International Thermal Operations and Heavy Oil

Symposium.

# Appendix

%Modelling oil reservoir and multilateral in Matlab

%%%%%%%%%%SOLUTION

% Pres=240 bar, WHP=40 bar L=600 [m]

%%%%%%%%%%ASSUMPTIONS

---

%

%2D model is considered

%Time t=1

%

%TVD (True Vertical Depth) starts from the well head.

%

%Overpressure reservoir

%

%Boundaries for the Well Length are established acc.to Joshi's condition. Thesis-->> equation (7)

%

%

%

---

inp=input('PRESS << 1 >> for isotropic reservoir case or PRESS << 2 >> for anisotropic reservoir case: ');

aaa=1;

bbb=2;

if inp==aaa

beta=1

elseif inp==bbb

beta=1.41

else

disp('No data found as per your request');

end

%CONSTANTS

---

%dx=10;

%dx=5;%[m]

dx=1;

ppermeability=100;%[mD]

permeability=ppermeability\*10<sup>(-12)</sup>;%[m2]

k=beta\*permeability;

kh=75\*10<sup>(-12)</sup>;%horizontal permeability [m2]

kv=kh/beta<sup>2</sup>;%vertical permeability [m2]

gradient=0.1;

g=9.81;

h=30.48;%[m] reservoir height

TVDmin=500;%[m] Assumed minimum depth where the reservoir can be located

```

TVDmax=3000; %[m] Assumed maximum depth where the reservoir can be
located

Re=1219; %[m] maximum drainage distance Re=Re(a,b)

My1=2e-3; %[Pa*sec] Viscosity

Nyg=2e-5; % [Pa*sec] Kinematic

Roi=800; %[kg/m3] Undersaturated oil

Rog0=1.5; % [kg/m3] Gas pressure in normal conditions

B=1; %Formation volume factor FVF

%Be careful when changing wellhead pressure, it affects iterations

Rw=0.108; %[m] 8.5'' Mainbore

D1=2*Rw*1.134; %[m] Production casing

D2=2*Rw/1.214; %[m] Liner

Rwan=(Rw/2) * ((1+beta)/sqrt(beta));

%Assumption a=2*b; Major axis of the ellipse is two times more than
minor
%axis
a=sqrt(2)*Re;
aa=round(a,0);
b=aa/2;

%%%%%INPUTS
disp('*****');
fprintf('Chosen step is %0.0f\n',dx);
disp(sprintf('...Pressure drop per %0.0f meters...',dx));
disp('*****');
disp(' ');

%Boundary for the reservoir pressure is 344 bar = 5000 psi considered,
%since H=H(Pres) and Pres is an input
hmax1=gradient*TVDmax;
hmin1=gradient*TVDmin;

%Boundaries for the Reservoir Pressure
ppres=input('Enter the reservoir pressure [bar] Pres=: ');
while ppres <hmin1 || ppres>hmax1
    disp(sprintf('Maximum reservoir pressure does not fit [72, 4351]
PSI and [%0.0f,%0.0f] bar limit \n',hmin1,hmax1));
    ppres=input('Enter the reservoir pressure [bar]: ');
end

Pres=round(ppres,0); %Clearing decimals

```

```

mmm=0;
while mod(Pres,dx) ~=0
    Pres=Pres-1;
    mmm=mmm+1;
end

pb=0.9*Pres;
Pb=round(pb,0);

TVD=Pres/gradient;
disp(sprintf('For the given Reservoir Pressure the assumed length of the
vertical section will then be %0.0f meters',TVD));

disp(' ');

WHP=input('Specify Pressure on the Well Head [bar]: ');
while WHP>100
    disp(' ');
    disp('The Well Head Pressure you specified is too big for the given
reservoir (100 bar is the current limit)');
    WHP=input('Specify Pressure on the Well Head [bar]: ');
end

%Length of the horizontal section [m]

ll=input('Enter the length of the well [m] L=: ');

%Check for Joshi condition.
llmin=30;
Joshicondition=0.9*Re;
while ll<llmin || ll/2>Joshicondition
    disp('The given well Length does not satisfy Joshi condition');
    disp(' ');
    ll=input('Enter the length of the well [m]:');
end
L=round(ll,0);%rounding the Length to an integer

%while mod(L,step) ~=0
    %L=L-1;
%end

mm=1;
while mod(L,dx) ~=0

    L=L-1;
    mm=mm+1;
end

H=TVD;

%Establishing location of perforations
mp1=0;
mp2=0.2*L;
mp3=0.4*L;
mp4=0.6*L;

```

```

mp5=0.8*L;

p1=round(mp1,0);
p2=round(mp2,0);
p3=round(mp3,0);
p4=round(mp4,0);
p5=round(mp5,0);
Perfor=[p1,p2,p3,p4];

%Adjusting location of perforations to step
for ii=1:max(size(Perfor))
    pp(ii)=Perfor(ii);
    while mod(Perfor(ii),dx)~=0
        Perfor(ii)=Perfor(ii)-1;
        pp(ii)=Perfor(ii);
    end
end

%Establishing starting claculation point scp
lpc= Perfor(max(size(Perfor)));%last perforated cell

n=(lpc/dx)+1;%Number of the last perforated cell

%Establishing the grid
Nv=H/dx;
Nh=L/dx;
N=(L+H)/dx;
n1=((H+L)/dx)+1;
r=100;% Cells to collect trash values

%Establishing two position vectors
%Make i and j to be same length, errase elements from Lpos and Pwi
%accordingly

Lpos(1)=0;
for j=2:N+1+r
    Lpos(j)=Lpos(j-1)+dx;
end

randomvector(1)=0;
for i=2:N+1+r
    randomvector(i)=0;
end

%Set perforations flag
Kxi=zeros(Nh);
for j=1:N+1+r
    for iper=1:max(size(Perfor))

        if Lpos(j) == Perfor(iper)

            Kxi(j)= 1;

        end
    end
end
end

```

```

Lpos=Lpos(1:n1);

%Calculating Skin Factor
Sd=2.2;
Sh=log((a+sqrt(a^2-(L/2)^2))/(L/2))+beta*h/L*log(beta*h/2/Rw)-
log(Re/Rw);

%Establishing Productivity index
J1=(0.00708*k*h)/(Myl*B*(log(0.472*Re/Rw)+Sh+Sd));
J2=(2*pi*kh*h)/(Myl*B*(log((a+sqrt(a^2-
(L/2)^2))/(L/2)))+(beta*h/L)*log(beta*h/((beta+1)*Rwan)));

if inp==aaa
    J=J1*10^5;
elseif inp==bbb

    J=J2*10^5;
    Rw=Rwan;
else
    disp('No data found as per your request');
end

%Conversion
% 1 bar=14.5038 PSI
% 1 m3 = 6.29 bbl
% 1 day = 86400 sec

conversion=(6.29/14.5)*86400;

Jconv=J*conversion;%Productivity index converted to [STB/(DAY-PSI)]
%-----

%Emperical amendment for J1
if J==J1*10^5
    J=J1*10^6;%Times 10 to raise output value of BHFP
end

%Launch iterations
Relerr=1;
Errlimit = 1e-5;
count = 1;
Corec=2;
disp(' ');
Pwi(1)=input('Guess Bottom Hole Flowing Pressure value [bar]: ');
while Pwi(1)<Pb || Pwi(1)>Pres
    disp(sprintf('Gues value must not exceed Pres and Pb [%0.0f -
%0.0f] bar',Pb,Pres));
    disp(' ');
    Pwi(1)=input('Guess Bottom Hole Flowing Pressure value [bar]: ');
end
disp(' ');
Pstart(count)=Pwi(1);

%%Starting iterations
confirm=input('Rress << 1 >> to start iterations: ');

if confirm==1

```

```

Relerr=1;
Errlimit = 1e-3;

count = 1;

Pstart(count)=Pwi(1);
Corec=5;

while abs(Relerr) > Errlimit

count = count+1

Pwi(1) = Pwi(1) - Corec*Relerr; % Pressure in the first cell
(Assumption)
Pstart(count)=Pwi(1);

%Initial mass inflow is zero
Mtot = 0;

for i=1:Nh
    D=D2;
    if Kxi(i)==1
        Minn=Rol*J*(Pres-Pwi(i));

        Mtot=Mtot+Minn;
    end

    Rom=Rol;
    Mym=Myl;
    Ulsi(i)=Mtot/(Rol*(pi*D^2/4));
    Umix(i)=Ulsi(i);
    Epsgi(i)=0;
    if Pwi(i)<Pb % Detect if boiling takes place
        % Use linear dependence of gas fraction
        % deviation from bubble point pressure

        GOR(i)=.5*(Pb-Pwi(i))/(Pb-1);
        Mgi(i)=GOR(i)*Mtot;
        Mli(i)=Mtot-Mgi(i);
        Rog=Pwi(i)*Rog0;
        Ugsi(i)=Mgi(i)/(Rog*pi*D^2/4);
        Ulsi(i)=Mli(i)/(Rol*pi*D^2/4);
        Umix(i)=Ulsi(i)+Ugsi(i);
        Epsgi(i)=Ugsi(i)/Umix(i);
        Myg=Nyg*Rog;
        Rom=Rog*Epsgi(i)+Rol*(1-Epsgi(i));
        Mym=Myg*Epsgi(i)+Myl*(1-Epsgi(i));

    end

    Reyn=Rom*Umix(i)*D/Mym;
    if Reyn < 4000
        disp('Laminar flow')
    end
    Frik=.046*Reyn^(-.2);
    Dpdx=(4/D)*Frik*.5*Rom*Umix(i)^2;
    Pwi(i+1)=Pwi(i)-Dpdx*dx*1e-5;

```



```

end

%Run through TVD

for i = Nh+1:N+1+r
    D=D1;
    Rom=Rol;
    Mym=Myl;
    Ulsi(i)=Mtot/(Rol*pi*D^2/4);
    Umix(i)=Ulsi(i);
    Epsgi(i)=0;
    if Pwi(i)<Pb
        GOR(i)=.6*(Pb-Pwi(i))/(Pb-1);
        Mgi(i) = GOR(i)*Mtot;
        Mli(i) = Mtot-Mgi(i);
        Rog = Pwi(i)*Rog0;
        Ugsi(i) = Mgi(i)/(Rog*pi*D^2/4);
        Ulsi(i) = Mli(i)/(Rol*pi*D^2/4);
        Umix(i) = Ulsi(i)+Ugsi(i);
        Epsgi(i) = Ugsi(i)/Umix(i);
        Myg = Nyg*Rog;
        Rom = Rog*Epsgi(i)+Rol*(1-Epsgi(i));
        Mym = Myg*Epsgi(i)+Myl*(1-Epsgi(i));

        end
    Reyn = Rom*Umix(i)*D/Mym;
    Frik = 0.046*Reyn^(-.2);
    Dpdyf = (4/D)*Frik*.5*Rom*Umix(i)^2;
    Dpdyh = Rom*g;
    Dpdy = Dpdyf + Dpdyh;
    Pwi(i+1) = Pwi(i)-Dpdy*dx*1e-5;
end

    % Get rid of optional values until the last cells

Pwi=Pwi(1:n1);
GOR=GOR(1:n1);

figure(1)
subplot(2,1,1); plot(Lpos,Pwi)
xlabel(' Position along well (m) ')
ylabel(' Well pressure (bar) ')

subplot(2,1,2); plot(Lpos,GOR)
xlabel(' Position along well (m) ')
ylabel(' GOR ')

Relerr= 0.8*(Pwi(Nh+Nv)-WHP)/WHP;

count;
Relstore(count)=Relerr;
end
    BHFP=Pstart(count);

    iWHP=zeros(1,N+1+r);
for i=1:N+1+r
    iWHP(i)=WHP;

```

```

end
iWHP=iWHP(1:n1);
figure(2)

plot(Lpos,Pwi)
xlabel('Position along the well [m]')
ylabel('Pressure [PSI]')

hold on
plot(Lpos,iWHP)
hold off

else
    disp('Unknown command encountered, please run the program again');
end

%%%-----END OF SECTION 1-----
-

%Estimating the number of cell where boiling occurs
n=0;
for jjj=1:max(size(GOR))
    n=n+1;
    if GOR(jjj)~=0
        break
    end
end
Vector=Lpos(n);

%Detecting testing point
Qb=J*(Pres-Pb)*1e-1; %To release emperical multiplication by 10 at the
line (294)

%Converting m3/sec to STB/(day)
QbSTB=Qb*6.29*24*3600;
gor=GOR(max(size(GOR)));

disp(' ');
disp(' ');
disp(' ');
disp('*****')
disp(sprintf('Bottom Hole Flowing Pressure is %0.0f [bar]',BHFP));
disp(sprintf('Steady State Productivity Index is equal to %0.0f
[STB/(day-PSI)]',Jconv));
disp(sprintf('Testing point Q(Pb) = %g [m3/sec], which is around %0.0f
[STB/day]',Qb,QbSTB))
disp(sprintf('Boiling point is assumed to be 90 percent of the average
Reservoir Pressure Pb = %0.0f [bar]',Pb));
disp(sprintf('Gas Oil Ratio (GOR) at the Well Head is %f',gor));
disp(sprintf('Boiling occurs at %0.0f m from the toe',Vector));
disp(sprintf('For the given Well Length the best choice for perforations
is [%g, %g, %g, %g] meters', [pp(2),pp(3),pp(4),p5]));

```

```

%%%%% Establishing Qmax
Qmax=Qb/(1-0.2*(Pb/Pres)-0.8*(Pb/Pres)^2);
Qmaxconv=Qmax*6.29*24*3600;

disp(sprintf('Qmax is %.f [STB/Day]',Qmaxconv));
disp(sprintf('CHECK FOR THE CONVERGENCE OF THE PRESSURE PLOT. IF NO,
THEN CHANGE THE WELL LENGTH '))
disp('*****')
disp(' ')

%IPR curve
ppresconv=Pres*14.5038;
Presconv=round(ppresconv,0);
ds=10;
Pbconv=Pb*14.5038;
Pbconv=round(Pbconv,0);
nx=Presconv/ds;
Nx=round(nx,0);

Pwf(1)=0;
for j=2:Nx+1
    Pwf(j)=Pwf(j-1)+ds;
end

for j=1:Nx+1
    x(j)=Pwf(j);
    if x(j)>Pbconv
        qipr(j)=Jconv*(Presconv-Pwf(j));
    else
        qipr(j)=Qmaxconv*(1-0.2*(Pwf(j)/Presconv)-
0.8*(Pwf(j)/Presconv)^2);
    end
end

figure(3)
plot(qipr,Pwf)
xlabel('STB/Day')
ylabel('Pressure [PSI]')

in2=input('Press << 1 >> to proceed to TPR plot: ');
if in2==1
%
%Chocke test
gc=32.2;

Dtpr=0.12;
Dtpr2=0.157;

Umax=Qmax*4/(pi*Dtpr^2);

Ub=Qb*4/(pi*Dtpr^2);
du=Umax/length(qipr);

U(1)=0;

```

```

for i=2:15000 % 15000 was chosen to be random number as Ptptr tends
toward infinity
    U(i)=U(i-1)+du;
end

for i=1:15000
    pPtptr(i)=(Pwi(Nh+1)-20)/1.5+0.005*Frik*Ro1*U(i)^2/(2*gc*Dtptr2);
    Ptptr(i)=pPtptr(i)*14.5;
end

for i=1:15000
    pPtptr2(i)=(Pwi(Nh+1)-20)/1.5+0.005*Frik*Ro1*2*U(i)^2/(2*gc*Dtptr2);
    Ptptr2(i)=pPtptr2(i)*14.5;
end

for i=1:15000
    pPtptr3(i)=(Pwi(Nh+1)-20)/1.5+0.005*Frik*Ro1*3*U(i)^2/(2*gc*Dtptr2);
    Ptptr3(i)=pPtptr3(i)*14.5;
end

for i=1:15000
    pPtptr4(i)=(Pwi(Nh+1)-20)/1.5+0.005*Frik*Ro1*4*U(i)^2/(2*gc*Dtptr2);
    Ptptr4(i)=pPtptr4(i)*14.5;
end

figure
plot(qipr,Pwf,'LineWidth',1.5)
xlabel('STB/Day')
ylabel('Pressure [PSI]')

hold on
p11=plot(Ptptr,'LineWidth',1.5)
xlabel('STB/Day')
ylabel('Pressure [PSI]')
p12=plot(Ptptr2,'LineWidth',1.5)
xlabel('STB/Day')
ylabel('Pressure [PSI]')
p13=plot(Ptptr3,'LineWidth',1.5)
xlabel('STB/Day')
ylabel('Pressure [PSI]')
p14=plot(Ptptr4,'LineWidth',1.5)
xlabel('STB/Day')
ylabel('Pressure [PSI]')

tit=title('Production tubing 6.18 ID')
tit=title('Production tubing 4.77 ID')
set(tit,'FontSize',12)
lgd=(legend([p11 p12 p13 p14],'Single Horizontal','Half of Dual
Lateral','Third of Tripple Lateral','Forth of Quad Lateral'));
%lgd=(legend([p11 p12 ],'Single Horizontal','Half of Dual Lateral'));
set(lgd,'FontSize',12)

end

```