

PAPER • OPEN ACCESS

Experimental and numerical study of Bondura® 6.6 PIN joints

To cite this article: I Berkani *et al* 2017 *IOP Conf. Ser.: Mater. Sci. Eng.* **276** 012028

View the [article online](#) for updates and enhancements.

Related content

- [Numerical investigation of contact stresses for fretting fatigue damage initiation](#)
N A Bhatti and M Abdel Wahab
- [Numerical Study on Microwave Scattering by Various Plasma Objects](#)
Wang Guibin, Zhang Lin, He Feng et al.
- [Summarized proceedings of the eleventh annual conference of the Stress Analysis Group - Leicester, April 1957](#)
A F C Brown

Experimental and numerical study of Bondura® 6.6 PIN joints

I Berkani¹, Ø Karlsen^{2*}, H G Lemu¹

¹Faculty of Science and Technology, University of Stavanger, Stavanger, Norway

²Bondura® Technology, Bryne, Norway

*Contact Author: oyvind@bondura.no

Abstract. Pin joints are widely used in heavy-duty machinery such as aircrafts, cranes and offshore drilling equipment to transfer multi-dimensional shear forces. Their strength and service life depend on the clamping force in the contact region that is provided by interference fits. Though the interference fits provide full contact at the pin-hole interface under pretension loads, the contact interface reduces when the pin is subjected to an external load and hence a smaller contact surface leads to dramatic increase of the contact stress. The PIN joint of Bondura® Technology, investigated in this study, is an innovative solution intended to reduce the slack at the contact surface of the pin joint of heavy-duty machinery by using tapered sleeves on each end of the PIN. The study is aimed to better understand the contact pressure build-up and stress distribution in the supporting contact surface under pre-loading of the joint and the influence of temperature difference between part assembly and operation conditions. Numerical simulation using finite element method and diverse experimental tests were conducted. The numerical simulation and the test results, particularly the tests conducted with lubricated joints, show good conformance.

1. Introduction

Several components of heavy-duty machinery are usually assembled using interference fit that is one of the low cost joining methods and widely used in the industry [1]. Interference fit can be seen as a semi-permanent joint and, if properly designed, the assembled system can resist the relative movement of the parts. Thus, the high radial pressure created at the interface can transmit forces or torques without a relative motion at the contact interface. If improperly designed, i.e. too much slack is created, for instance, between bolts or pins and the mating surface, operation of heavy-duty machinery with slack can be a key issue with serious consequences. Wear and tear in the joints can increase maintenance costs and can reduce the service life of the whole system, but the most serious consequence is loss of human life. Slack occurs because of the bolt being smaller than the mating surface due to either contact surface wear during operation or due to too small interference fit between the parts. In a conventional pin-support connection the force is applied to one single point, this will result in the deformation of the support (host surface) and continues until the support is worn out and thus has to be replaced.

The risk of having slack in a pin-joint depends on the level of the clamping force at assembly and the behaviour and size of the external load. The clamping force is mostly introduced by press or shrink fit where a pin with a larger diameter than the corresponding hole is pressed into the hole or the assembly is done by freezing the support or freezing the bolt using liquid nitrogen respectively. When the whole assembly returns to operating temperature, the pressure created at the interface allows transmission of forces or torques [2]. This might appear as an acceptable solution, but disassembly of the parts can be



demanding in certain cases. For instance, it may demand that the pin can only be detached from the support by torch cutting, which has a high associated cost and does not guarantee the safety of equipment. This is where the Bondura® Technology, which introduces rather simple but impressive concept, i.e. the Bondura® PIN joint comes in. It is an innovative solution intended to reduce the slack at the contact surface of the pin joint of heavy-duty machinery such as in offshore installations, among others, drilling and hoisting/lifting machinery by using tapered sleeves on each end of the PIN. Figure 1 illustrates the components involved in one of the Bondura® PIN joints i.e. Bondura® 6.6. In this assembly, clamping force is induced by tightening bolts that push a conical sleeve along the pivot pin and creating a press load on the internal surface of the assembly.

Compared with the conventional press or shrink fit where the load is focused on a line along the mating surface, the Bondura® PIN joint offers 360° distribution of the load in the joint while preloading due to the fact that the tapered sleeves on each end of the PIN are wedged into place and eliminate any slack. When external force is acting, this load is distributed over 180° of the contact surface. The tapered sleeves of the PIN assembly can also eliminate the wear problem due to ovality. The Bondura® bolt is found in usage in a variety of areas on heavy machinery and they are also certified for usage offshore by DNV GL (Det norske veritas) and ABS PDA (American Bureau of Shipping Product Design Assessment).

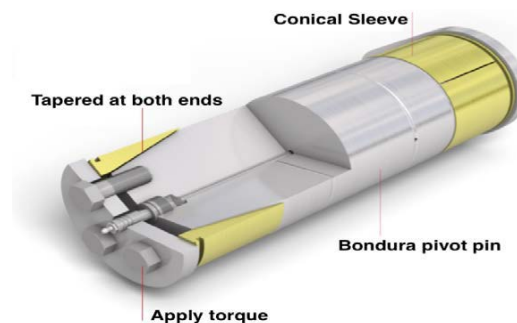

Figure 1. Illustrative picture of Bondura® 6.6 product series

Calculation of interference fit in the design process is normally based on the classical theory of Timoshenko [3] that assumes the interface as the thick-walled tube theory with internal pressure. This assumption may be valid for simple cylindrical parts and it does not allow for the calculation and simulation of the behaviour in most industrial cases [4]. In addition, the application of the traditional methods to design of interference fit is limited to 2D stress analysis under loading within the elastic region. On the other hand, recent studies are mostly based on simulations using finite element method (FEM) that facilitates study of the stress and deformation distribution at the interface [5, 6] using a virtual model. This study asserts that 3D analysis of interference fitted connections are best obtained by using FEM approach when compared with the traditional design based on the thick-wall cylinder theory. One clear advantage of the approach is that the actual geometry and working conditions can be accounted for in the model. FEM based approaches to design of interference fits are also reported using finite load incremental theory [7] for frictional contact analysis and stress pattern analysis of the shrink fit of liner and sleeve in presence of high temperature and pressure [8]. Predicting the contact pressure, which highly depends on the contact geometry, is one of the challenges in the design of interference fits. A study of the mechanics of interference fits in dental implants [9] shows that tapered fits provide better reliable connection.

Following this introduction section, the article is divided into six main sections. Section 2 presents the motivations for conducting the study. The main research parts of the work, i.e. experimental and numerical study are presented in Section 3 and 4 respectively. Then the results obtained from the two aspects of the research are compared and discussed in Section 5. Finally, the concluding remarks are given in Section 6.

2. Motivation and Problem Description

This article reports a study conducted as part of a master thesis by the first author [10]. The study was initiated by Bondura® Technology Company to better understand performance of its Bondura® 6.6 product series. Among others, the company wants to investigate the performance of the Bondura® PIN joints in terms of

1. the relation between the tightening torque and the radial stress/strain generated at the contact surface and
2. the influence of temperature variation between location of assembly and operation of the system, for instance in cases where the product is assembled in a low temperature region such as in Norway and operated in high temperature region such as the Middle East, and vice-versa.

Thus, the study focuses on developing numerical simulation models for two products of the Bondura® 6.6 PIN series, namely Bondura® 6.6 Ø88,9 and Bondura® 6.6 Ø120, conducting experimental tests on both products and compare the analysis results with experimental investigation. The study was conducted by varying tightening torque of bolts, lubrication conditions and temperature variations.

3. Experimental Study

In this study, a total of two Bondura® 6.6 PINs were tested. The test samples have diameters of 88,9 mm and 120 mm, and both samples are 201 mm long. The mechanical properties of the components of the two product series, as obtained from the material certificates and standards (EN 10083-3 & EN 10269) are given in Appendix A (Table 3) together with illustration of the components in the assembly. As stated earlier, the objective of the tests was to find the relationship between the torque generated upon tightening the screws, and the radial stress/pressure generated due to reactions in the supports. To begin with, the tests were carried out under room temperature, and later on, the ambient temperature was varied while documenting the stress effect observed at the supports.

3.1. The Experimental Methods and Materials

The two Bondura® 6.6 PINs are assembled and connected to the Test Jig on one end, as recommended in the Installation manual, i.e. the pivot pin was inserted so that the end surface is flush with outer surface of the support of the jig. Then, the components (conical sleeves, plate and screws) were assembled and the screws were tightened alternately to the specified torque on this end.

A test boss with cylindrical form, which acts as a second support, was inserted at the other end of the test PINs. The test boss has an insert with a Distance Indicator-X, as shown in Figure 2, so that Bondura® Multi Tool can be used for gentle and easy removal of conical sleeve. Figure 3 illustrates a fully assembled Bondura® 6.6 PINs that are ready for testing.

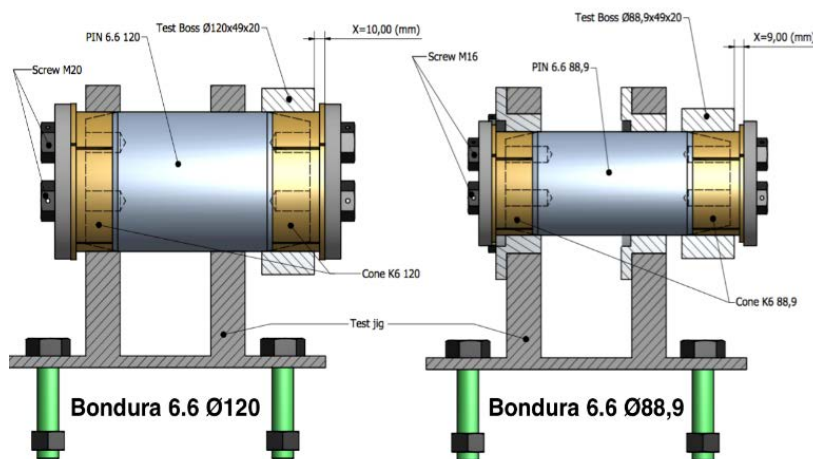

Figure 2. Test boss with a distance indicator-x



Figure 3. Illustration of the test assembly for the two test setups

To examine the loading and make mechanical stress analysis, measurements were performed with strain gauges. Four strain gauges were bonded to the test bosses with a cylindrical form, which will act as a support. Several tests at different angles were executed at room temperature. The first test boss position was fixed in such a way that the measuring points are parallel with the center of the surface of the conical sleeve. The test boss was then tilted 45° from the first position so that the measuring points become parallel to the cutting opening of the conical sleeve. The location of strain gauges around the test bosses is illustrated in Figure 4.

Before starting the test, the friction surfaces of the PIN joints and conical sleeves of both test cases were cleaned, dried and made free of any oil and grease substances. This was to make the samples thoroughly cleaned and free of any unwanted particles that might interfere in the measurement process.

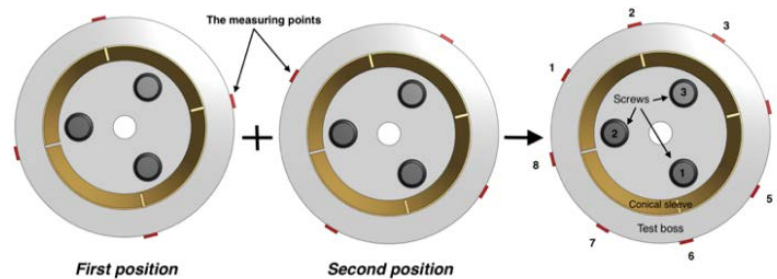

Figure 4. Illustration of the location of strain gauges

To ensure that the conical sleeves do expand correctly according to the installation manual, it was found important to tap with a hammer on the plates. This step had to be skipped during testing because the test boss is not fixed, and because of the strain gages’ sensitivity, which can result in incorrect measurements.

The screws were tightened using a torque wrench. Table 1 shows the applied torque values under measurement. The measurement process was repeated alternatively until all indicated torque has been applied to the screws, and all corresponding reaction forces have been registered.

Table 1. List of measured torques

Bondura® 6.6	Applied torque [Nm]						
Ø88,9	120	140	160	180	200	--	--
Ø120	290	310	330	350	360	370	380

To measure at higher temperatures, the screws were first tightened to 180 Nm and 350 Nm torque for Bondura® 6.6 Ø88,9 and Bondura® 6.6 Ø120 respectively. The whole structure is then moved into the oven, and the temperature of the oven was increased stepwise to 40 °C and then to 60 °C. The reaction forces were registered at room temperature, and the change in the reaction forces due to temperature change to 40 °C and 60 °C were registered.

With the application of the transient heat conduction theory and air velocity in the oven, the time that heat uses to get inside the core of pivot pins was calculated. To avoid any measurement errors and make sure that correct measurements were taken, the structure was left one hour more in the oven.

3.2. The Experimental Results

Tangential and axial strain on the external surface of the test bosses was measured with strain gauges, while radial stress/pressure on internal surface of test bosses was calculated using Catman software based on the thick-walled cylinder theory for all positions. This was done by increasing the temperature starting from room temperature and the screw threads were lubricated.

The test was repeated at least three times in each position at room temperature and twice at increased temperature. The experimentally obtained results of radial stresses on internal surface (contact surface between test boss and conical sleeve) are illustrated graphically (Figure 5). Each of the differently coloured graphs in this figure represents one of the eight measuring points.

3.2.1 Test results of Bondura® 6.6 PINs at room temperature: For test conducted on Bondura® 6.6 Ø88.9, as the torque increases (i.e., when the screws are tightened), the compressive radial stress continues to increase. The plots in Figure 5 show the development of the radial stress at the different eight measuring points. It is worthy to point out that the pressure varies in the different measuring points, as the screws continue to be tightened alternately. There appears to be intervals where the radial stress remains stable, this is when the tightening is paused so that the value of the radial stress generated will be more apparent for each value of the applied torque. The pills along the applied torque direction indicate the transition from a torque value to another, i.e. while tightening.

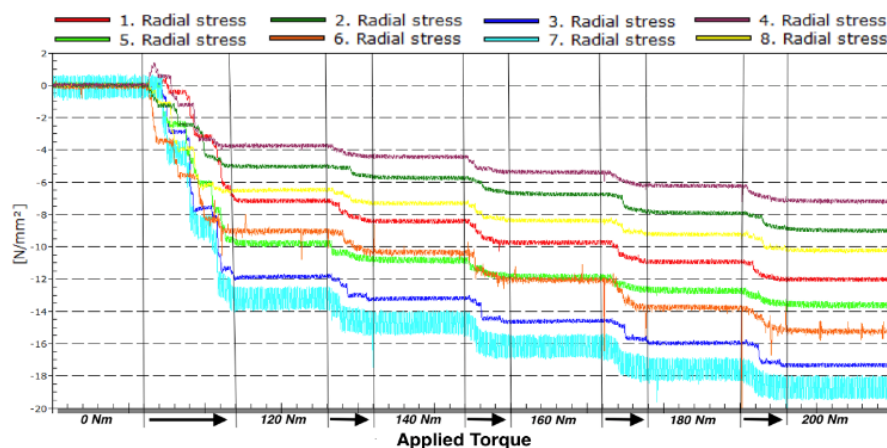

Figure 5. Variation of radial stresses with torque for Bondura® 6.6 Ø88.9

Comparably, for the Bondura® 6.6 Ø120, the compressive radial stress increases as the screws are tightened (the torque increases) as shown in Figure 6. This trend does not apply to all the points of measurement as it is the case for the Bondura® 6.6 Ø88.9. At measuring point 7, which is located between the first and the second screw, the radial stress remains positive throughout the whole tightening procedure. The positive radial stress value indicates the absence of any pressure existing in this point. Another particular observation is the case of point 3 (the blue graph) that is characterized by frequent noise throughout the tightening process. The noise is reduced as the tightening is stopped and a value becomes readable in the graph. This noise might be resulting due to the sensitivity of the strain gauges near the measurement point.

While tightening bolted connections, the tightening torque goes partly to preload the bolt and partly consumed in overcoming frictional resistance in the threaded contact between the male and female parts and the bearing/collar friction at the flat surface of the fastener or nut head.

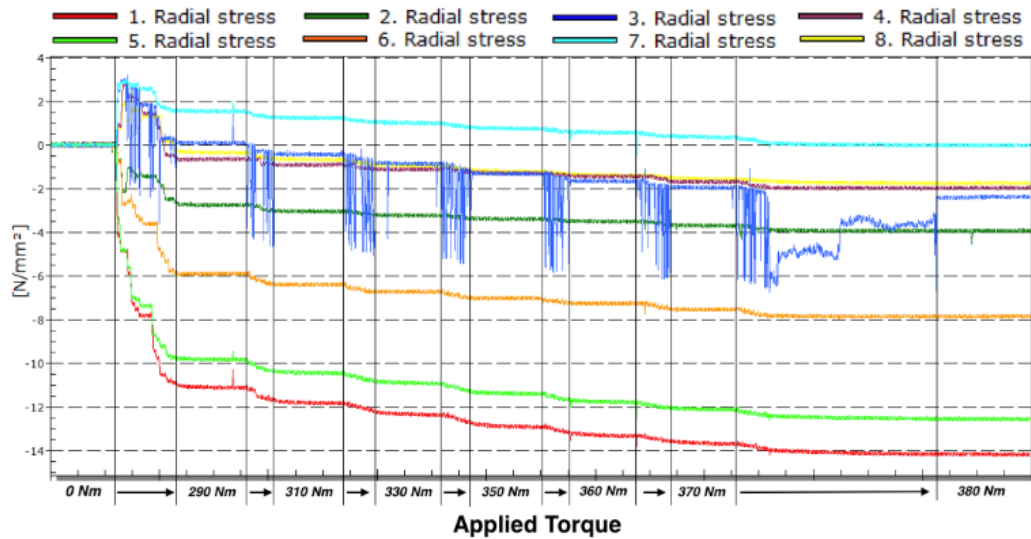

Figure 6. Variation of radial stresses with torque for Bondura® 6.6 Ø120

Many studies indicate that about 90% of the tightening torque is consumed by friction, while only 10% is used as a useful torque to preload the bolt [11]. In other words, the torque–preload relationship is highly sensitive to friction that is influenced by factors such as joint geometry [12], physical property of bolt material [13], lubrication [14], surface finish [15], etc.

Though the accuracy of the method in terms of controlling the amount of the preload of the bolt is seriously limited, the common method of tightening bolted connections is using torque wrench. A simplified torque–preload relationship for this method is given by [14, 16];

$$T = k \cdot F_0 \cdot d \quad (1)$$

where T = tightening torque by torque wrench, k = torque coefficient (where $k = 0.2$ is recommended for standard screw threads), F_0 = bolt preload and d = the nominal diameter of the bolt. The bolt sizes used for the two Bondura® PIN sizes, namely Bondura® 6.6 Ø88,9 and Bondura® 6.6 Ø120, are M16 and M20 respectively.

To study the influence of friction while applying tightening torque and record the changes in stresses/pressure applied to the test boss, the Bondura® 6.6 PINs were again tested after lubricating the screw threads and data on the contact pressure (Table 2) and radial stress (Figures 7 and 8) were registered.

It is observable from Table 2 that the average pressure in the contact surface, for both dry friction and lubricated threads, increases with increasing torque. Comparing the percent increase for each applied torque, higher pressures are generated when the threads are lubricated implying that friction loss is reduced and more torque is used to preload the bolt. For Bondura® 6.6 Ø88,9, the percent increase of the average pressure, in general increases with increasing torque, while the reverse is observed for Bondura® 6.6 Ø120. In this case, though the average pressure in dry friction noticeably increases with the torque, the average pressure under lubricated thread condition show insignificant change.

From the plots of the radial stresses in Bondura® 6.6 Ø88,9 and Bondura® 6.6 Ø120 given in Figures 7 and 8 respectively, the most significant observed changes are described as follows:

- Radial stress/pressure curves approach each other in the four measuring points, giving better pressure distribution.
- The order of radial stresses (from minimum to maximum values) in those four measuring points changed.
- Bondura® 6.6 Ø120 gets higher average pressure increase compared with the dry friction case.
- The radial stresses are higher for lubricated screw threads of Bondura® 6.6 Ø88.9, while they are almost stable for Bondura® 6.6 Ø120.

Table 2. Average pressure while tightening at dry friction and lubricated threads

Bolt	Applied torque [Nm]	Average pressure [MPa]		Pressure increase (%)
		P_{av_dry}	$P_{av_lubricated}$	
Bondura® 6.6 Ø88,9	120	6.06	6.93	14.3
	140	6.96	8.19	17.7
	160	8.14	9.82	20.6
	180	9.28	10.20	9.9
	200	10.45	12.72	21.7
6.6	290	4.79	9.47	97.7
	310	5.30	10.67	101.3
	330	5.70	10.93	91.8
Bondura® Ø120	350	6.20	11.01	77.6
	360	6.53	11.07	69.5
	370	6.82	11.11	62.9
	380	7.27	11.15	53.4

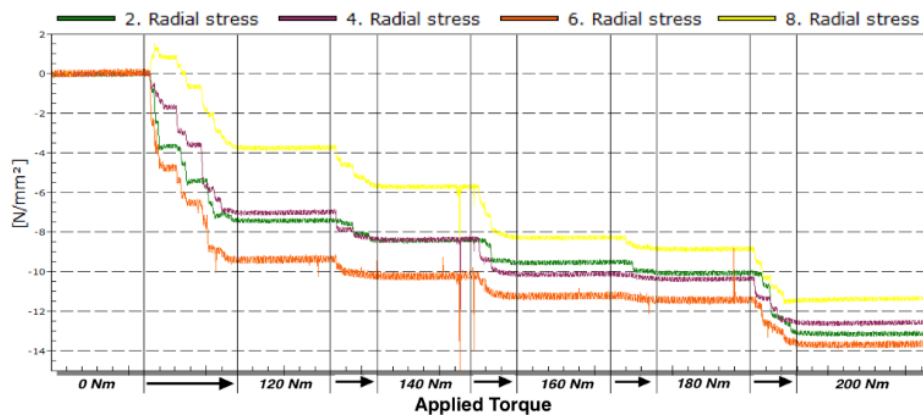

Figure 7. Plot of radial stresses for Bondura® 6.6 Ø88,9

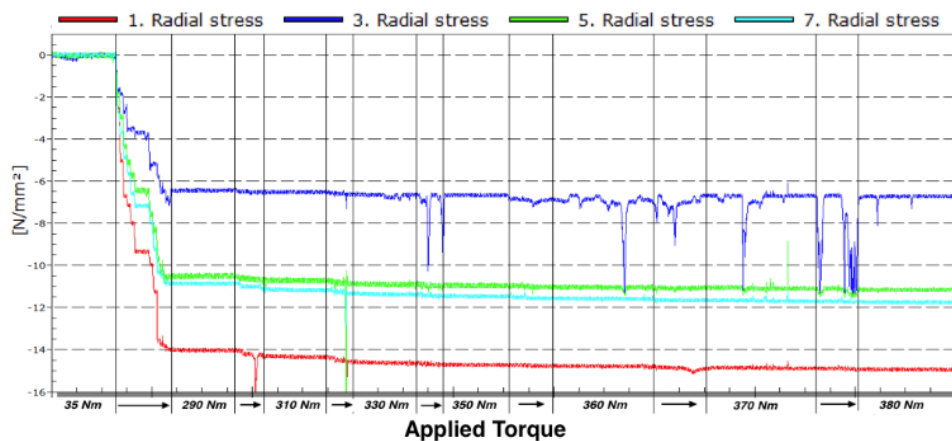

Figure 8. Plot of radial stresses for Bondura® 6.6 Ø120

3.2.2 Test results of Bondura® 6.6 PINs at higher temperature: The temperature was varied throughout the system after assembly at room temperature. With increasing test temperature, higher compressive radial stresses are observed for both pin joints, as depicted in Figure 9 for Bondura® 6.6 Ø88,9 and Figure 10 for Bondura® 6.6 Ø120. Compared with room temperature tests, the results of higher temperature tests show more stable trend with increased temperature.

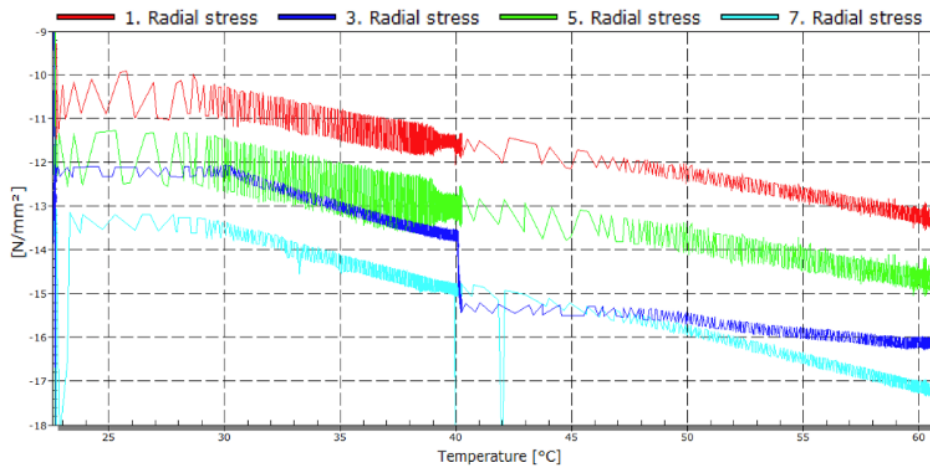

Figure 9. Plot of radial stresses for Bondura® 6.6 Ø88,9 at higher temperature

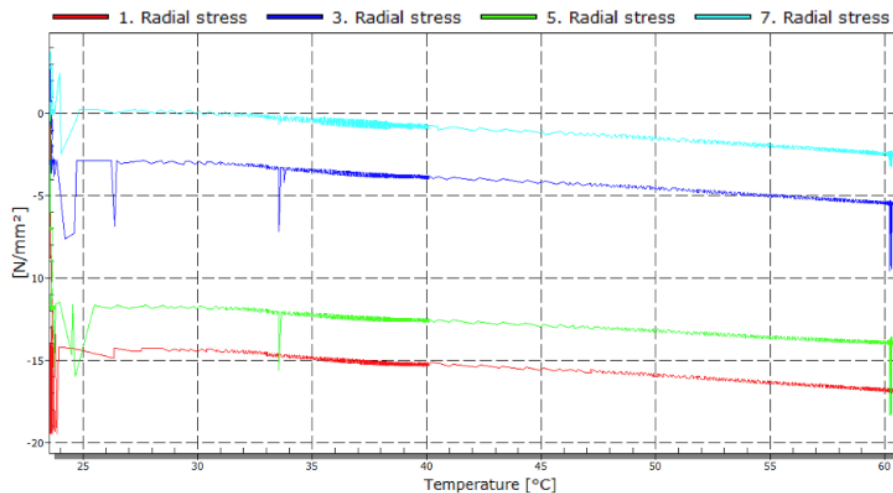

Figure 10. Plot of radial stresses for Bondura® 6.6 Ø120 at higher temperature

4. Numerical Study

Finite Element Method is, nowadays, an approach widely used for stress analysis of mechanical systems. Though the method is used to get approximate solutions, the approach leads to better understanding of the stresses and strains in the mechanical system at lower cost, and near accurate results can be obtained provided that the system is properly modelled with relevant boundary conditions. In this study of Bondura® 6.6 PIN joints, the radial stresses/pressure distribution on internal surface of test bosses was investigated using finite element analysis in ANSYS Workbench. In addition, the stress distribution, axial deformation and pressure change with respect to temperature variation are calculated for both test bosses. The goal is to obtain approximate solutions of Bondura® 6.6 test PINs and compare the results with data from the experimental, which can be used as a validation of the simulation model.

4.1. Simulation methodology

The Computer-aided Design (CAD) models of Bondura® 6.6 PINs have been developed using Inventor CAD application and imported the solid geometry into the FEM analysis tool in ANSYS Workbench. To perform the simulation, the necessary Pre-processing steps including adding material properties to Engineering Data, creating a Coordinate System, defining contact surfaces and setting up loads and supports have been done.

The Bolt Pretension load option available in ANSYS Workbench was employed to allow pretension loads produced by the installation torque of tightening the bolts (from Table 1) to be easily analyzed. Preload was applied gradually on the screws.

For the temperature fluctuation analysis, Thermal Condition was added to the simulation, where the temperature is defined at 22 °C under applied preload, and the thermal condition is ramped up step-by-step to 60 °C for high temperature analysis, then ramped down through the same steps to -40 °C for low temperature analysis.

4.2. Simulation results

To explore the effect of Bondura® 6.6 PINs pressure on the support, the radial stress in the test boss's contact surface against the conical sleeve was computed. In the following section, radial stress affecting contact surface of test bosses from conical sleeve of pins are presented graphically.

4.2.1 Simulation of Bondura® 6.6 PINs at room temperature: The simulation results of the computed radial stresses for the two PINs, Bondura® 6.6 Ø88,9 and Bondura® 6.6 Ø120 are plotted in Figures 11 and 12 respectively. In those figures, the minimum and maximum radial stresses that are calculated for both test bosses with every tightening step are shown. The results show that radial stress distribution is different almost around 360° contact surface of the test boss.

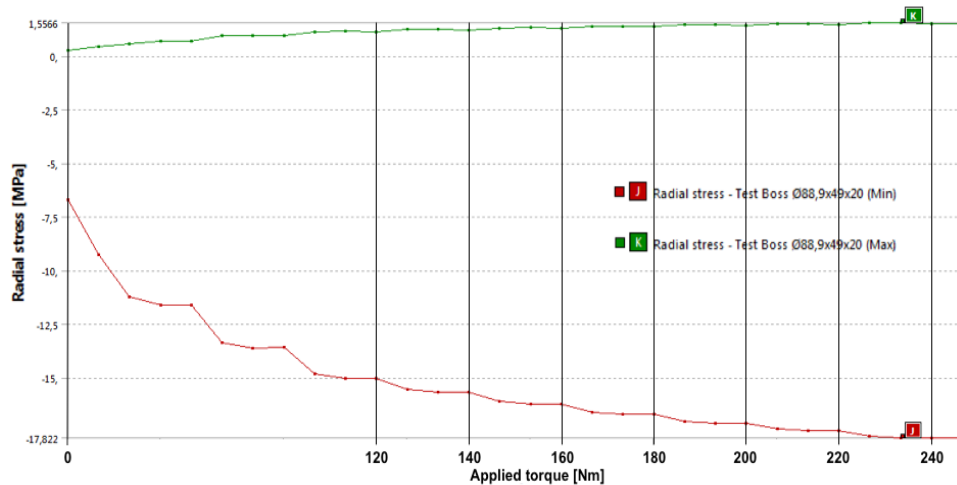

Figure 11. Computed radial stresses (max. & min) for Bondura® 6.6 Ø88,9

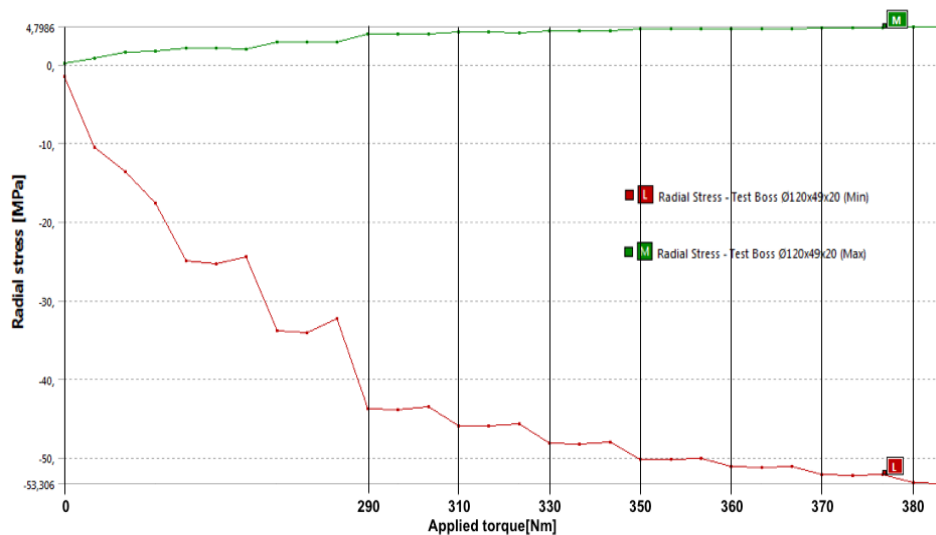

Figure 12. Computed radial stresses (max. & min) for Bondura® 6.6 Ø120

In other words, the stress distribution on the contact surface of the test bosses is not uniform as can be observed from the stress patterns given in Figure 13. The maximum radial stress experienced in the area close to the screw are all within the frustum area for Bondura® 6.6 Ø88,9, and it also centers the test boss's contact surface to conical sleeve as seen Figure 13(a), (b) and (c). This distribution of radial stress/pressure is more optimal, as it is more circularly symmetrical. The highest stress in the area close to the first screw for test boss of Bondura® 6.6 Ø120 is within frustum area, as seen in Figure 13(a'), while the second tight screw gets less stress as shown in Figure 13(b'). In the cross section of the third tight screw, a minimum stress is in the frustum area. Furthermore, the numerical analysis shows that the highest stress is experienced near the edge of the conical sleeve for the third screw, Figure 13(c'). This is due to the test boss deformation resulting from alternate screws tightening.

Deformation of test bosses in axial direction (z-direction) is calculated during simulation and the results are shown in Figures 14 & 15 for Bondura® 6.6 Ø88,9 and Bondura® 6.6 Ø120 respectively. The test boss of Bondura® 6.6 Ø88,9 (Figure 14) experiences little differences between maximum and minimum deformation, throughout the whole preload procedure. On the contrary, the test boss for Bondura® 6.6 Ø120 (Figure 15) experiences major difference between maximum and minimum deformation under preload at the same step. The most significant deformation happens in boss area that is close to the third screw.

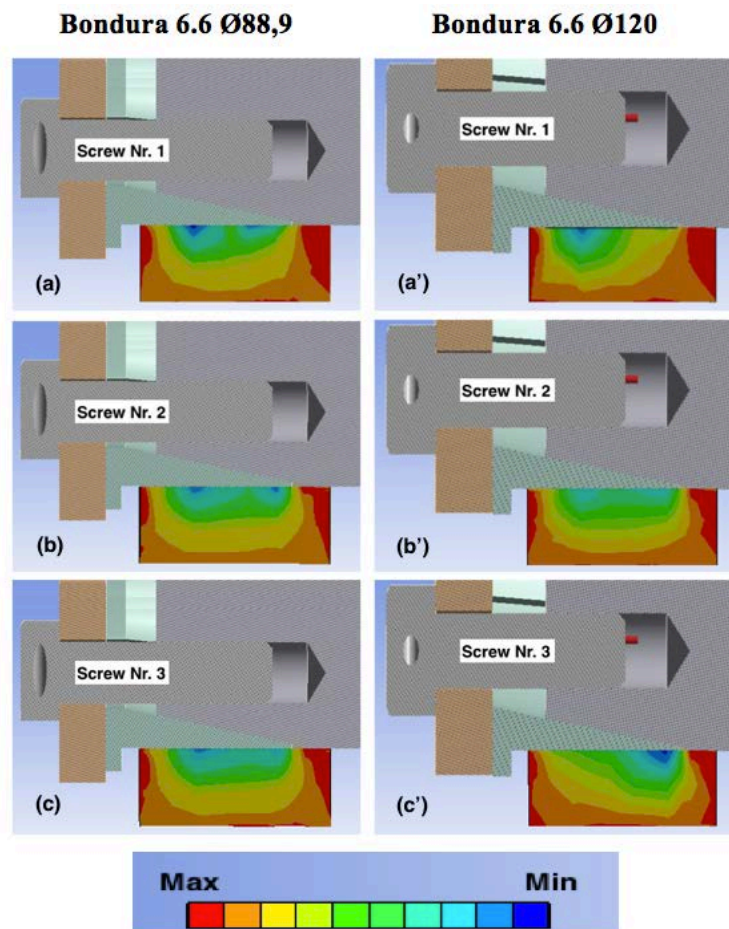

Figure 13. Simulated stress patterns of Bondura 6.6.Ø88,9 (Left) and Bondura 6.6 Ø120 (Right)

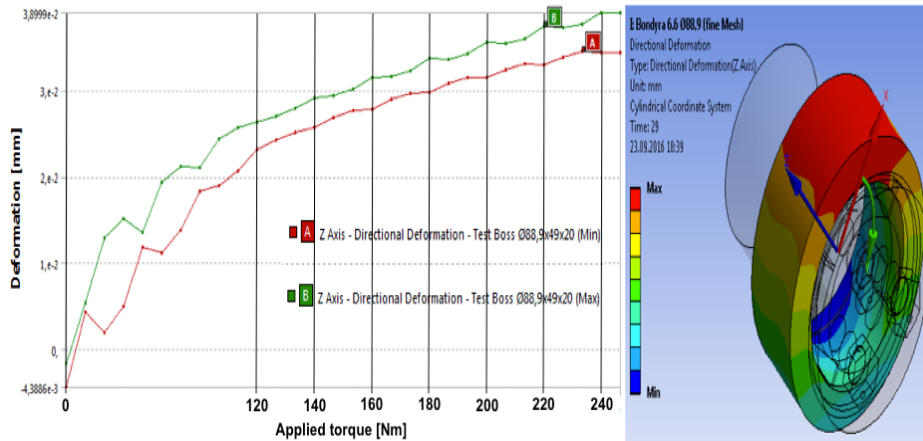

Figure 14. Axial deformation of Bondura® 6.6 Ø88,9 as a function of applied torque

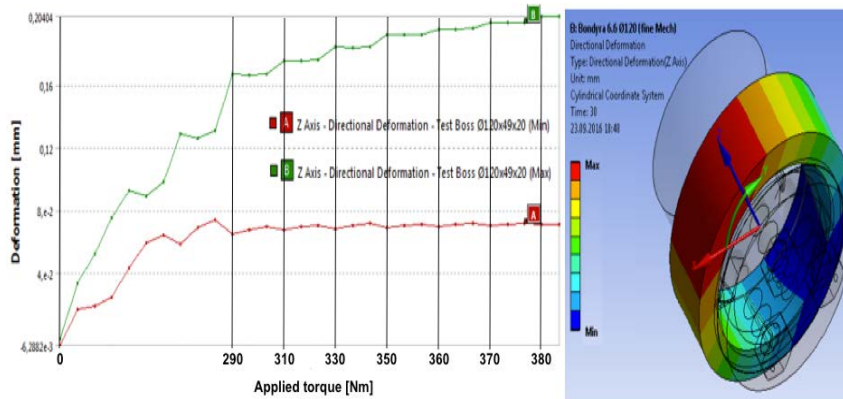

Figure 15. Axial deformation of Bondura® 6.6 Ø120 as a function of applied torque

Simulation of Bondura® 6.6 PINs at temperature fluctuation: Upon variation of the temperature, the minimum radial stress distribution was studied using ANSYS and the result for both test bosses is shown in Figure 16. In this case, there appears to be very little change in radial stress for both Bondura® 6.6 PINs.

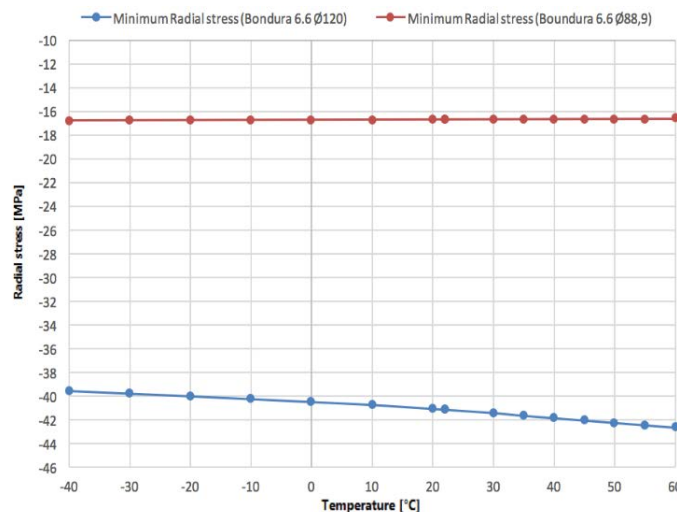

Figure 16. Minimum radial stress of Bondura® 6.6 PINs as a function of temperature

5. Discussion and Comparison of Results

The distinct feature of the Bondura® PINs is its ability to distribute the pressure 360° in its envelope. The experimental work has shown that this can be achieved in the case of Bondura® 6.6 Ø88,9 at room temperature. On the other hand, the experiment was not able to confirm the same results for Bondura® 6.6 Ø120. There appears to be an absence of pressure in a certain measurement point inside the test boss, which might discredit the initial claim. These results, however, are not definitive and might have occurred due to several factors, including the following:

- *Not hammering of the assembly*: It is instructed that the plate structure connected to the conical sleeve is to be hammered during mounting. This is to ensure that the latter expands correctly. A decision to neglect this step was made since the hammering would have resulted in considerable noise readings from the strain gauges.

Unfixed test boss: This means the test boss moves with conical sleeve when torque is applied. This is not the case under industry applications where the surrounding structure is fixed.

The analysis performed at room temperature mainly indicates an uneven distribution of pressure over the 360° contact surface between the conical sleeve and the test boss for both Bondura® 6.6 PINs. When the simulation plots were further examined, potential factors causing this were identified. These are size of the screw used and its resulting frustum area, the positioning of these screws relative to the test boss and the deformation of the test boss occurring when tightening.

Theoretically, the clamping force increased to a value surpassing 10% when the screws are lubricated and, in turn, the average pressure measures increased. Figure 17 shows the average pressure of Bondura® 6.6 PIN joints with and without-lubricated screw threads. The experimental test results show that the average pressure increases by approx. 17% for Bondura® 6.6 Ø88,9 while the average pressure of Bondura® 6.6 Ø120 gets an increase about 80%. Another noticeable thing is that the pressure distribution is more even when mounting the structure after lubrication.

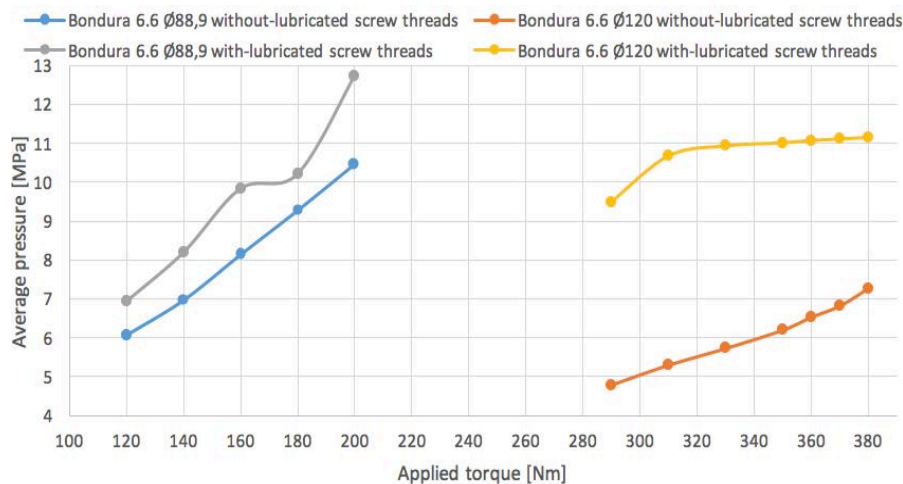

Figure 17. The average pressure of Bondura® 6.6 PINs with & without-lubricated screw threads

Under experimental testing, measurements are taken at only four points positioned on the external surface of the test boss. Using theoretical calculations, pressure on the inside surface was then calculated. Four points measurement may not be sufficient to get a clear idea of the behavior of the pins. This is because a very limited area of the surface of the test boss is covered by these points. The numerical analysis on the other hand, provides a lot more data. The entire contact surface to the test boss towards Bondura® 6.6 PINs can be checked, and even stress distribution into the material, deformation and status of the contact surfaces could be animated and plotted.

When the results from the experimental testing and numerical analysis are compared, it is observed that the pressure of the experimental testing is within the maximum and minimum pressure interval produced by the numerical analysis. The modelled pressure values in the mid contact surface of test boss

to Bondura® 6.6 Ø88,9 are within close range of the values obtained through the experimental work, while the test boss of Bondura® 6.6 Ø120 had an average pressure that was higher in the numerical analysis than the ones measured under the experimental testing. It is possible to state that stress distribution is similar for both the experimental testing and the numerical analysis. There appears to be more pressure close to the first tight screw and less close to the last, this applies mainly to the area where the measurement points were set under the experiment.

Since the test bosses get different pressure in each of the measuring points, shear stress is generated. Moreover, the numerical analysis shows that the test bosses get some axial stress in the contact surfaces due to friction of deformation of the test bosses. The existence of shear stress and axial stress that was disregarded in the equation used for the calculation of the experimental results might be the error source in this case, causing a deviation in the results between the experimental testing and numerical analysis.

Another issue that should be pointed out regarding the numerical analysis is that the design requirements for FEM model with the tightening option “bolt pretension” are often obtained by a simple clamping force (axial load). During experimental work, the applied torque generates not only the axial loading but also the collar friction and thread friction. With lubricated thread, axial load is increased and hence a more “pure” force transition is achieved. This is why the pressure with lubricated threads during experimental testing is very similar to pressures in simulation.

In the case of temperature fluctuation, it is expected that the pressure is going to be constant for Bondura® 6.6 Ø88,9, given the fact that the thermal expansion coefficient is equal in all its components. However, the experimental results depict a drop in radial stress. This contrast might be due to the measurement being taken on the outside, and the software calculating the desired pressure inside. These assumptions might not be very accurate in determining the changes occurring along the thickness separating the placement of the strain gauges, and the desired measurement point inside when temperature is involved.

For Bondura® 6.6 Ø120, there appears to be a pressure variation in the form of a rising trend as it is depicted. This is in accordance with the initial expectation given that the thermal expansion coefficient varies from the pivot pin to the rest of the components. Since the coefficient for the pivot pin is larger than the surrounding components, it is deemed to expand more drastically compared to the components enveloping it.

Pressure is held constant with temperature variation in the numerical analysis of Bondura® 6.6 Ø88,9, this is expected due to the thermal expansion coefficient in all parts of the PIN all being too similar. In the experimental testing, pressure has increased about 9% with temperature increase. Regarding Bondura® 6.6 Ø120, pressure in both the numerical and experimental analysis is observed to be increasing with temperature increase. The average increase in pressure is about 13% during the experimental study and approximately 1.8% in the numerical analysis. Differences in the results for Bondura® 6.6 Ø88,9 may be due to the thermal expansion coefficient being the same in all parts. Since the strain gauges are on the external surface of test bosses, the material expansion might also be due to temperature increase, and not pressure increase on the internal surface. In this situation, calculations of pressure using the measured values during testing can possibly be a source of error.

6. Conclusion

The study conducted on two product variants of Bondura® technology (as a master thesis project) at University of Stavanger is partly presented in this article. Both experimental investigations and numerical simulation & analysis approaches were implemented. Both studies concluded that a 360° pressure distribution occurs throughout the cylindrical support. The pressure distribution in both pivot joints is documented to be circular asymmetrical, the highest pressure being registered in the area closer to the first tightened screw.

From the two product variants, extremely uneven pressure distribution is registered for Bondura® 6.6 Ø120 under the experiment. The numerical analysis showed similar results for the same area, but it has also disclosed that although the pressure was minor in the measured point, most of the pressure occurs at the edge of the conical sleeve.

Lubricating the screw threads has resulted in an improved pressure distribution for both Bondura® 6.6 assemblies. Consequently, the average pressure increases relative to pressure registered for non-lubricated screw threads indicating the fact that the frictional loss is reduced and part of the torque that could have been lost is converted into preloading of the bolts. In general, the results from the experimental investigation and numerical analysis show similar trends, particularly for Bondura® 6.6 Ø88,9, though non-conclusive results are observed for the experimental work with temperature variation.

This study has revealed a number of potential future research areas on the product series. The test boss, in this study, was not fixed against axial movement, and hence constraining its motion while preloading the screws and using several tangential strain gauges can provide better control of the stress/pressure distribution under the experiment. Other possible further works include; low temperature test with proper instrumentation, post installation investigation of the pivot joints and simulation of the numerical model with high performance FEA tools.

Acknowledgement

The authors would like to acknowledge the support of Yaaseen A. Amith in setting up the laboratory tests in the Metrology and Solid Mechanics Lab of the Department of Mechanical & Structural Engineering and Materials Science, University of Stavanger.

References

- [1] Truman C E and Booker J D 2007 Analysis of a shrink-fit failure on a gear hub/shaft assembly *Eng. Fail. Anal.* **14** pp. 557–72
- [2] Wick C and Veilleux R F 1987 *Quality control and assembly – tool and manufacturing engineers handbook vol. 4.* (MI, Dearborn: Society of Manufacturing Engineers)
- [3] Timoshenko S P 1956 *Strength of materials Part II: advanced theory and problems. 3rd ed.* (Krieger Pub. Co) pp. 205-13
- [4] Boutoutaou H, Bouaziz M and Fontaine J F 2013 Modelling of interference fits with taking into account surfaces roughness with homogenization technique *Int. J. Mech. Sci.* **69** pp. 21–31
- [5] Zhang Y, McClain B and Fang X D 2000 Design of interference fits via finite element method *Int. J. Mech. Sci.* **42** pp.1835–50
- [6] Sen S and Aksakal B 2004 Stress analysis of interference fitted shaft–hub system under transient heat transfer conditions *Mater. Des.* **25**(5) pp. 407-17
- [7] Okamoto N and Nakazawa N 1979 Finite element incremental contact analysis *Int. J. Numer. Methods Eng.* **14** pp. 337 - 57
- [8] Oh J H, Lee S J and Lee D G 1997 Manufacturing of an alumina linear-steel sleeve under high pressure and temperature *Int. J. Mach. Tools Manuf.* **37** pp. 1511 - 23
- [9] Bozkaya D and Müftü S 2003 Mechanics of the tapered interference fit in dental implants *J. Biomech.* **36** pp. 1649–58
- [10] Berkani I 2016 *Contact stress and temperature variation analysis of Bondura bolts: Numerical and experimental study* (Master Thesis: University of Stavanger)
- [11] Zhu L, Hong J and Jianga X 2016 On controlling preload and estimating anti-loosening performance in threaded fasteners based on accurate contact modeling *Tribol. Int.* **95** pp. 181–91
- [12] Bickford J H 2007 *Introduction to the design and behavior of bolted joints: non- gasketed joints* (NewYork: Marcel Dekker)
- [13] Nassar S A, El-Khiamy H, Barber G C, Zou Q and Sun T S 2005 An experimental study of bearing and thread friction in fasteners *Trans ASME J. Tribol.* **127** pp. 263–72
- [14] Croccolo D, De Agostinis M and Vincenzi N 2011 Failure analysis of bolted joints effect of friction coefficients in torque-preloading relationship *Eng. Fail. Anal.* **18** pp. 364–73

- [15] Nassar S A and Sun T S 2007 Surface roughness effect on the torque–tension relationship in threaded fasteners *Proc. IMechE Part J: Eng. Tribol.* **221** pp. 95–103
- [16] Juvinall R C and Marshek K M 2006 *Fundamental of machine component design*. 4th ed. (Asia: Wiley & Sons Pt. Ltd.)

APPENDIX A

Table 3 contains mechanical properties of materials of parts the Bondura® 6.6 PIN joint assembly reported in this article. These material data are obtained from material certificates and Standards EN 10083-3 & EN 10269. The components of the assembly are also illustrated in Figure 18.

Table 3. Mechanical properties of components of Bondura® 6.6 product series

	PIN Ø88.9	PIN Ø120	Accessories *	Screws
Material type	34CrNiMo6 (SS2541)	42CrMo4V (SIS2244)	S355J2+N	8.8
Young's modul. [GPa]	190-210	190-210	200	210
Poisson's ratio	0.27-0.30	0.27-0.30	0.303	0.3
Yield strength [MPa]	962	784	403	640
Tensile strength [MPa]	1074	914	547	800
Thermal expan. [10 ⁻⁶ .K ⁻¹]	11.1	12.1	11.1	10.8

*ACCESSORIES: BOSS, CONE SLEEVE AND PLATE

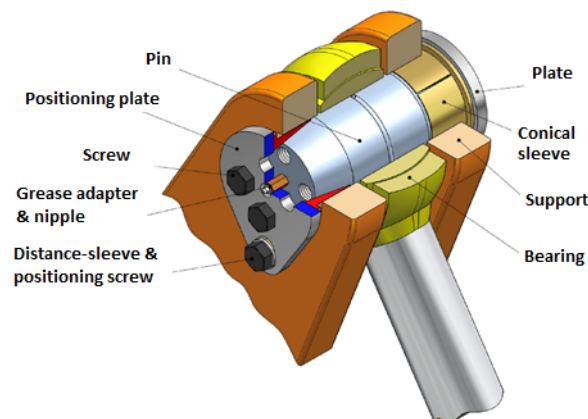
**Figure 18.** Illustration of components of Bondura® 6.6 assembly