



FACULTY OF SCIENCE AND TECHNOLOGY

MASTER'S THESIS

Study program: Industrial Asset Management	Spring semester, 2019 Open/ Confidential
Author: Magnus Høgden <i>Magnus Høgden</i> (signature of author)
Programme coordinator / Supervisor: Professor Jayantha Prasanna Liyanage, PhD Supervisor: Karina Djuve Aanderaa – Kverneland Group	
Title of master's thesis: Developing a framework for predictive maintenance for a land-based company from an Industry 4.0 perspective	
Credits: 30	
Keywords: Industry 4.0 Predictive Maintenance Agricultural equipment industry Cyber-physical systems	Number of pages: 97 Stavanger, 15.06.2019

Abstract

The manufacturing industry today is filled with buzzwords like Industry 4.0, digitalization and automation. Emerging technologies enable operators and companies to better control asset lifetime, operations, failures and maintenance. The majority of the benefits obtained through the emerging technologies are achieved by analysing collected data. The transformation of data from the physical plane into the cyber-physical one is challenging, often due to lack of standards for organizations and work processes. With these challenges at its core, Industry 4.0 and digitalization projects are difficult to navigate around to make them successful.

This thesis focuses on answering the research question of: *“How can a framework for predictive maintenance be developed and implemented in a land-based company in a cost-efficient way”* in order to address the challenges in the industry. Hence, the framework developed will act as a guideline for a process of developing and implementation of predictive maintenance compliant with the Industry 4.0 concept.

The selected industrial case study is Kverneland Group and the focus of this thesis is related to the A300 mechanical forge press at their factory at Klepp as this is evaluated as their top 10 most critical equipment based on value produced. In order to evaluate the framework developed, it is demonstrated in use through our case study, on a machine and organizational level.

The framework presented in this thesis proposes a six-layered approach toward development and six-steps for implementation of predictive maintenance. The process proposed for how these can be combined is presented through a four-step model based on the framework and strategy developed.

The system analysis of the A300 was used as a critical element in evaluating the framework for the development of a predictive maintenance system. This methodology was used to identify the most critical assets and subsystems, as it would capture the critical elements with the most potential and benefits by being enabled by Industry 4.0 technologies and making the analogue to digital transformation. The analysis highlights the most critical failure scenario within the A300, it also suggests parameters that can be used for monitoring purposes. This

monitoring is performed by vibration sensors that detect the shift in the natural frequency as a symptom of failure.

The framework developed illustrates how the six-layered architecture can be used to form a standardised approach to predictive maintenance development. It elaborates on the different layers and their respective requirements, which can be used when establishing a predictive maintenance system. This framework was further used in developing a six-step model for successful implementation of predictive maintenance along with a systematic process approach that complies with the Industry 4.0 concept.

The cost benefit analysis performed concludes with that the cost of establishing and maintaining a predictive maintenance system is a viable option. For a period of 10 years, monitoring the specific machine fault discovered and implementing predictive maintenance, could potentially mitigate the risk cost associated with it.

Preface

This project is a collaboration between Kverneland Group and the University of Stavanger and is written in the spring semester of 2019 as part of a MSc degree in Industrial Asset Management.

The case study and framework for this thesis was developed in collaboration with Industrial Supervisors Egil Brastad Hansen and Karina Djuve Aanderaa. On the basis of this framework a research question was developed by the author.

I would express my greatest gratitude to Kverneland Group and my assigned supervisors for the opportunity to participate in this collaboration. I would also like to thank everyone for their time and interest in my thesis along with the all knowledge they have shared with me in this process. Special thanks to Karina Djuve Aanderaa for always being available for questions and taking the time for me in a hectic schedule.

I also would like to thank Professor Jayantha Prasanna Liyanage for his perseverance and guidance during my education and the writing of this thesis. I have learned a lot from his guidance and feedback on this thesis and his level of knowledge on Industrial Asset Management has inspired me throughout my studies.

A special thanks to my friends and family that have supported me and helped me keep my motivation up while combining work and writing this spring semester.

Lastly, a special thanks to Julie, for the patience, love and understanding in a time where the hours of the day never seemed like enough.

Magnus Høgden

University of Stavanger 15.06.2019

Contents

Abstract	ii
Preface	iv
Contents	v
Figure list	vii
Abbreviations.....	ix
1. Introduction	1
1.1 Challenge	2
1.2 Thesis description and scope	2
1.3 Thesis methodology.....	4
1.4 Thesis structure	5
1.5 Thesis limitations	6
2. Theory.....	7
2.1 Industry 4.0.....	7
2.1.1 Industry 1.0.....	7
2.1.2 Industry 2.0.....	7
2.1.3 Industry 3.0.....	8
2.1.4 Industry 4.0.....	8
2.1.5 Industry 4.0 and Maintenance.....	11
2.1.6 Systems thinking.....	15
2.1.7 Pugh Matrix	16
2.2 Maintenance	17
2.3 Maintenance programs	18
2.3.1 Corrective Maintenance (CM)	19
2.3.2 Preventive Maintenance (PM).....	20
2.3.3 Predictive Maintenance (PdM)	21
2.3.4 Proactive Maintenance (Pro-M)	23
2.4 Condition Monitoring	25
2.4.1 Failure analysis.....	26
2.4.2 Condition Monitoring Techniques	30
2.4.3 Vibration monitoring	31
2.4.4 Fault diagnosis with vibration analysis	35
3. Case study.....	39
3.1 Kverneland Gruppen.....	39
3.2 Organization	40
3.3 Production Process	40
3.4 Current maintenance program	42
3.5 Pilot project	44
4. Analysis of A300.....	45

4.1 System analysis.....	45
4.1.1 System boundary	45
4.1.2 Technical and Functional architecture.....	46
4.1.3 Monitoring practice for A300	49
4.1.4 System stakeholders	51
4.2 Failure analysis.....	52
4.2.1 FMECA	53
4.2.2 Rotating wheel element	55
4.2.3 Rolling element bearing.....	55
4.2.4 Rolling bearing defects	56
4.2.5 Pugh matrix.....	58
4.3 Development of a framework for predictive maintenance	60
4.3.1 Physical	60
4.3.2 Configuration	61
4.3.3 Cognition.....	63
4.3.4 Cyber	63
4.3.5 Conversion	64
4.3.6 Connection.....	65
4.4 Implementation strategy for predictive maintenance framework.....	66
4.4.1 Developing a predictive maintenance strategy	67
4.4.2 Defining requirements and needs	69
4.4.3 Obtain the knowledge required.....	69
4.4.4 Enable organizational change towards Industry 4.0.....	71
4.4.5 Establish pilot projects.....	71
4.4.6 Develop an ecosystem approach towards PdM	73
4.5 Cost-benefit analysis.....	74
4.5.1 Calculation of cost	74
4.5.2 Cost-effect summary	77
6. Discussion	78
6.1 What is learned.....	79
6.2 Main challenges	80
6.3 Further recommendations.....	80
7. Conclusion	82
References	A

Figure list

Figure 1 - Gallery of disruptive technologies [12].	9
Figure 2 - Smart factory aspects [13].	10
Figure 3 - Overview of Trends & Driving forces and Rapidly Developing Areas [16].	11
Figure 4 – RAMI 4.0 hierarchy [18].	12
Figure 5 - Global map of RAMI 4.0 [18].	13
Figure 6 - Cyber-physical system 5C components [19].	14
Figure 7 - IDEFØ description [20].	15
Figure 8 - Example Pugh Matrix [22].	16
Figure 9 - Historical development of maintenance [4].	19
Figure 10 – Framework for Prescriptive maintenance [29].	22
Figure 11 – Condition monitoring and diagnostics of machines [31].	25
Figure 12 - Example of an FMECA table [33].	27
Figure 13 - Condition monitoring technologies [34].	30
Figure 14 – The different aspects of vibration [36].	31
Figure 15 - Illustration of simple harmonic motion [37].	33
Figure 16 - Illustration of complex vibration [38].	33
Figure 17 - Piezoelectric Accelerometer [41].	35
Figure 18 - Different vibration fault spectrums [36].	36
Figure 19 Failure scenarios and their spectrum plots [34].	37
Figure 20 - Kverneland factory at Klepp, Norway [46].	39
Figure 21 - Main critical production steps.	40
Figure 22 - Factory overview [46].	41
Figure 23 - Top 10 critical equipment at Kverneland factory at Klepp [46].	42
Figure 25 -System boundary.	46
Figure 26 - Physical architecture of A300 [46].	47
Figure 27 - IDEF0 diagram.	49
Figure 28 – Monitoring use case scenarios.	49
Figure 29 - Process monitoring system view.	50
Figure 30 - Quality monitoring system view.	50
Figure 31 - Systems view of machine health monitoring.	51
Figure 32 – FMECA diagram [48].	54
Figure 33- Close up on the top part of the machine press [46].	55
Figure 34 - Ball bearing and roller bearing [50].	56
Figure 35 - Ball bearing failure scenarios [51].	57
Figure 36 – Six-layered predictive maintenance model.	60
Figure 37 - Illustrative solution of sensor placement on bearing element [57].	62
Figure 38 - Wonderware architecture [58].	63
Figure 39 - Cepstral Editing Procedure process map [59].	64
Figure 40 - Model for diagnosis and prognosis of machine faults [60].	65
Figure 41 – Key steps for a successful implementation of a predictive maintenance strategy [28].	66
Figure 42 - Process of development and implementation of predictive maintenance based on the framework and strategy developed.	66
Figure 43 - Physical to digital transformation [61].	67
Figure 44 - Level of maturity in technologies [62].	68
Figure 45 - Organizational roles in a digitalization process [63].	70
Figure 46 - Key areas of organizational change [63].	71
Figure 47 - Business goal matrix alignment [64].	72
Figure 48 - Pilot project scalability [65].	73

Table 1 – Overview of maintenance programs [24].	18
Table 2 – Overview of Corrective Maintenance	20
Table 3 –Overview of Preventive Maintenance	21
Table 4 – Overview of Predictive Maintenance [29].	23
Table 5 - Proactive maintenance [29] [30].	24
Table 6 - Severity description [33].	28
Table 7 - Occurrence description [33].	28
Table 8 - Detection description [33].	29
Table 9 - Explanations of Displacement, Velocity and Acceleration [36].	32
Table 10 - Overview of useful monitoring parameters [36].	32
Table 11 - Relevant machine faults tied to the case study [43] [44].	38
Table 12 - Stakeholder requirements and needs.	52
Table 13 – Illustrative installation and setup cost offer based on authors assumptions and interviews [47].	74
Table 14 - Life cycle cost for the next 10 years.	75
Table 15 – Expenses with repairing a bearing defect [48].	76
Table 16 - Cost-effect analysis summary.	77

Abbreviations

A/D - Device that transforms analogue signal into digital

A300 - Hasenklaver FRPN 300

AH - Main Assembly Hall

CM - Condition Monitoring

CPM - Cycles Per Minute

HMI - Human-Machine Interface

HSE - Health, Safety and Environment

MTTF - Mean Time To Failure

PdM - Predictive Maintenance

PM – Preventive Maintenance

Pro-M – Proactive Maintenance

RUL – Remaining Useful Lifetime

SCADA - Supervisory Control and Data Acquisition control system architecture

1. Introduction

The manufacturing industry is one of the industries which have the greatest potential for a digital transformation but is today moving relatively slow from an enterprise-wide and ecosystem-wide perspective. The driving forces of digital transformation are the same for manufacturing industries as other industries and industrial initiatives as Industry 4.0 and Industrial Internet help accelerate these transformations [1].

The transformation changes the expectations of the consumer and impacts the way the entire supply chain works. The key factors in this digital revolution is IoT and Industry 4.0 among others [2]. Manufacturing today is not only about making physical products as the changes in consumer demands, supply and economy is changing how companies do business. Today's consumers demand personalisation and turn in some cases into a creator in the process. Products are transformed from "dumb" products into "smart" using sensors and connectivity [3].

The changes in the way manufacturing is done changes on several fronts as advanced materials, automated smart machines and disruptive technologies are ushering in an industrial revolution. This shift is propelled by the increased connectivity and data capabilities that are emerging in the wake of Internet of Things (IoT) and Industry 4.0 [4].

Agricultural equipment has been used since the dawn of the ages and is mainly used in the farming industry. These kinds of machines are indispensable and contribute to feeding the growing world population. While minimal changes and development has been made through the last century the digital transformation changes the way they are operated. Using computer monitoring and advanced technological systems industrial solutions can be designed to bring forth a more effective and automated process.

1.1 Challenge

The industry today is changing, and new technologies are constantly emerging. Companies must be able to adopt these technologies to survive. The challenge is to find a way to implement these types of technologies in older and existing systems in a way that can help to improve the maintenance strategy. This can be difficult to effectively do, as there are very few Industry 4.0 standards and the developed maintenance programme needs to be cost-efficient for Kverneland Group to implement it [5].

The main challenges tied to implementing a maintenance programme based on Industry 4.0 has been identified as organizational, architectural, content & contextual and integrational challenges [6]. Organizational challenges mainly focus on the management of resources on an enterprise level. Where the challenges touches upon aspects like organizational restructuring, resource planning, information & knowledge management and organizational management. Architectural challenges deal mainly with the issues regarding the architecture of maintenance solutions. This includes framework developing and models for data analysis, data prognosis, visualization and data storage. Infrastructural challenges relate to the developing and implementation of services. These services can be tied to network infrastructure, maintainability, and user mechanisms. Content & contextual challenges relate to the data which are sourced through the services. These data raise challenges like integration of data, quality assurance mechanisms, user usability, mechanisms to manage uncertainty and pattern recognition. Integration challenges are related to the coordination and organization of services and data provided by maintenance solutions. These challenges can be management of services, management of configurations and integration across different platforms and technologies.

1.2 Thesis description and scope

This thesis and its formulated problems are based upon an industrial case provided by Kverneland Group. The main goal of this thesis is to provide Kverneland Group with information and solutions that can be beneficial for their company. The product formulation and research question were developed through discussion and use of a problem formulation guideline [7].

Kverneland Group is a global leading manufacturer of agricultural equipment having factories in several different countries. In Norway they have a factory at Klepp, a small village outside

Stavanger, which will be the main focus of this thesis. This factory consists of over 3000 different types of machines and equipment which produces different parts used in the production of agricultural equipment [8]. The maintenance strategy currently used is a mix between corrective maintenance (CM) and a preventive maintenance (PM). They have set their goals to transition into a condition monitoring based predictive maintenance program (PdM). This is made possible due to cheaper and more accessible sensors and monitoring equipment, combined with the trends and forces within ICT and “Industry 4.0” in today’s industry [9].

The focus of this thesis can be presented as:

1. How can a framework for Predictive maintenance be developed for critical equipment?
2. How can a predictive maintenance strategy be implemented?
3. What is the financial benefit of implementing a Predictive maintenance program?

From these questions the following research question is formulated:

“How can a framework for predictive maintenance be developed and implemented in a land-based company in a cost-efficient way.”

The scope of this thesis is to develop a framework for predictive maintenance that Kverneland Group can implement on their production process and organization. The main critical equipment identified by Kverneland Group is their rotating machinery, mainly mechanical forge presses and this will be the focus of this thesis. The literature study will explore Industry 4.0 and maintenance to establish a basis which are applicable to the case study. The case study used in this thesis will be limited to a specific type of equipment, more accurately their A300 mechanical forge press. This case study will be used as an example for how a developed framework for predictive maintenance can be implemented. This suggested strategy will be applicable to Kverneland Groups production process and intends to open new thoughts about how existing systems might be improved.

Kverneland Group's has expressed their desires that the following topics would be investigated:

- Predictive Maintenance implementation
- Condition Monitoring with regards to different sensors and their benefits
- Financial benefits to implementing a Predictive Maintenance program

To ensure that the needs identified, and the research question is properly investigated, the following project progress is proposed:

- January: Literature study and project planning with supervisors.
- February: Work at Kverneland Group. Analysing and interviewing. Deciding on a case study.
- March: Formulating specific problems and delimitation of project scope.
- April: Finalizing the case study and cost-efficiency analysis.
- May: Finishing the results, reporting and reviewing.
- June: Evaluation and corrections. Deliver 15th.

1.3 Thesis methodology

The most common research methods are quantitative and qualitative, and some of these are used in this thesis along with an extensive literature study. The literature study was mainly performed with review of books, web-articles and scientific reports. This was done to be able to present a thorough overview of how the Industry 4.0 concept and maintenance are intertwined.

Qualitative methods are mainly used as preliminary exploratory research and is often used to gain an understanding of the underlying motivations, reasons and opinions. It also provides a reasonable insight into the potential problem and provides the guideline for quantitative research. Some common qualitative methods can be interviews, observations and focus groups (group interviews).

Quantitative research is used to quantify the potential problem by generating or assigning numerical data so that it can be used as statistics. It is most often used to quantify opinions, behaviours and other variables. This method is objective and uses a standardized approach to

either prove or disapprove a hypothesis. The most important aspect of this kind of research is generating enough data for the method to be feasible and accurate.

This thesis will in order to gain a proper understanding of the system and potential problem at Kverneland Group use a qualitative approach, using casual interviews and observations with the maintenance personnel. The author was also given access to Kverneland internal documents and databases in order to better understand the work processes and technical language used. The data was also used to gain a better understanding of how the internal processes regarding maintenance and planning was performed. The interviews performed was casual face-to-face conversations as a part of the work period at Kverneland Group. This led to the interviews being more dynamic and the subjects divulged more background information regarding their opinions and work processes.

1.4 Thesis structure

The thesis is divided into six chapters. This overview shows the contents of each of the chapters in this thesis and is described further at the beginning of each chapter:

- Chapter 1: The first chapter introduces the reader to the manufacturing industry and its opportunities and challenges, as well as the thesis description, method, scope, structure and limitations.
- Chapter 2: Includes a literature review which investigates the background knowledge required of Industry 4.0, condition monitoring, systems thinking and maintenance for performing an analysis of the case study.
- Chapter 3: Consists of an introduction to the case study chosen and the background information related to it.
- Chapter 4: Consists of the main analysis of the A300 as well as a proposed predictive maintenance framework and how it could be implemented, and the cost-benefit associated.
- Chapter 5: Having established a proposed solution, the results from the analysis will be discussed.
- Chapter 6: Consist of a brief conclusion of the authors findings and recommendations.

1.5 Thesis limitations

The thesis limitations present in terms of how the case study is chosen and which system should be investigated, as the main focus areas are decided upon by Kverneland Group. There some connected limitations in how it is used in the development and validation of a predictive maintenance framework as there are limited technical data available for the A300. Thus, the developed solution is a general model and framework rather than a specific solution. This general solution will contain a framework for implementation of predictive maintenance in future digital factories. For the purpose of this report the most relevant technologies evaluated are limited to those derived from Industry 4.0 and maintenance.

There are limitations regarding what kinds of critical machines were analysed because of the already identified top 10 most critical machines in their factory. This thesis will be limited to the most critical identified, not the entire factory. Following the people available for an interview were mainly operators and the employees at the technical department at the factory. Some limitations were present in the form of lack of accurate historical data regarding the system in question, the A300.

The thesis was originally proposed to be a more specific solution and framework based on vibration data produced by the pilot project. This pilot project was delayed over a period of several months, based on this, the decision was made to make a more general framework. Also, due to lack of progress on the pilot project some assumptions had to be made by the author regarding cost and expenses. This decision made the cost-benefit model developed more general than specific and more of an estimate than an accurate result.

2. Theory

The thesis in its entirety revolves around the implementation and development of a Predictive Maintenance framework for a land-based production facility in the time of digitalization and cloud technology. This chapter will present the background knowledge and insights in Maintenance, Condition Monitoring, Systems Thinking and Industry 4.0 needed for the case study.

This chapter will contain:

1. Industry 4.0
2. Maintenance
3. Maintenance programs
4. Condition Monitoring

2.1 Industry 4.0

Industry 4.0 is by many described as the fourth industrial revolution because of the major changes in the way we produce products with the help of digitalization. The emergence of Industry 4.0 is built on the foundation of emerging technologies, and the trends, forces and previous industrial revolutions that are driving it will be covered through this chapter.

2.1.1 Industry 1.0

The First Industrial Revolution is dated to have taken place from the 18th to 19th century and took place during a period which the agrarian rural societies in America and Europe transformed into industrial and urban environments. During this period the main technological invention was the steam engine, which had the greatest impact on agriculture, transportation and the manufacturing industry [10].

2.1.2 Industry 2.0

The Second Industrial Revolution is dated to have taken place between the 19th and 20th century. The main driver of this phase of rapid industrialization was the invention of electricity. This invention gave rise to mass production and assembly line infrastructure [11].

2.1.3 Industry 3.0

The Third Industrial Revolution is dated to have taken place between the 1970 and present day. The main drivers of this phase were the invention of the Internet and the Programmable Logic Controller (PLC). These inventions made possible great developments in computational and data analysis technologies and helped digitalize manufacturing industries [12].

2.1.4 Industry 4.0

The Fourth Industrial Revolution have been unfolding in the wake of the emergence of the Internet and is been described as a Cyber-Physical revolution. In the long line of Revolutions that have preceded it, computerization and the Internet of Things are now driving factors in this new one. The transformation in the way things are made and the digitalization of manufacturing is the main reasons why this period is called the fourth revolution [13].

This revolution is emerging in the wake of many new disruptive technologies and some of them are identified in the figure below. Here they are sorted after both potential economic impact and disruption capacity. These technologies are described by Harvard professor Clayton M. Christensen as [14]:

“A disruptive technology is one that displaces an established technology and shakes up the industry or a ground-breaking product that creates a completely new industry. “

A gallery of disruptive technologies

Estimated potential economic impact of technologies across sized applications in 2025, \$ trillion, annual

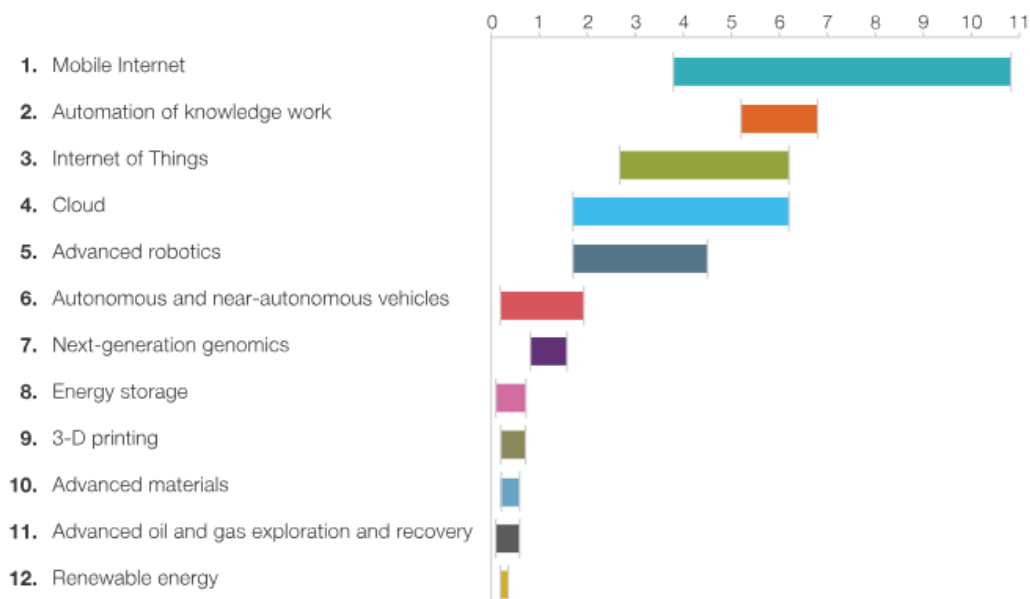

Figure 1 - Gallery of disruptive technologies [15].

Some examples of disruptive technologies that have pushed the boundaries and empowered change historically are [14]:

- Steam Power
- Electricity
- The personal computer (PC)
- Mobile phones
- Cloud computing
- Social networks

During their time these technologies completely disrupted and revolutionized the industry. The enhancing of computers and automation with systems powered by smart and autonomous solutions is in many ways the computerization of industry 3.0. To be able to introduce Industry 4.0 in a value chain there are some terms and concepts that are essential for the implementation [16]:

Cyber Physical Systems (CPS) – A cyber physical system exists in situations where there is a cooperation between a physical machine and a computer system. The computer system controls and monitors the machine and receives data in return [17].

Internet of Things (IoT) – The Internet of Things can be described as a system of devices that are connected and given unique identifiers and the ability to transfer data over a network. IoT is in many ways one of the key enablers of Industry 4.0 [16].

Internet of Services (IoS) – Internet of Services is a term used when not only describing things connected to the internet but also services. The idea is that a system should be able to go online and use services that are relevant in their area. This means that services need to be designed and developed with focus on interoperability. So that the service is made in a way that it can be used by other systems for their purposes [16].

The connection between these can be described as a smart factory concept. The interconnectivity of these aspects can be illustrated in the following figure [18].

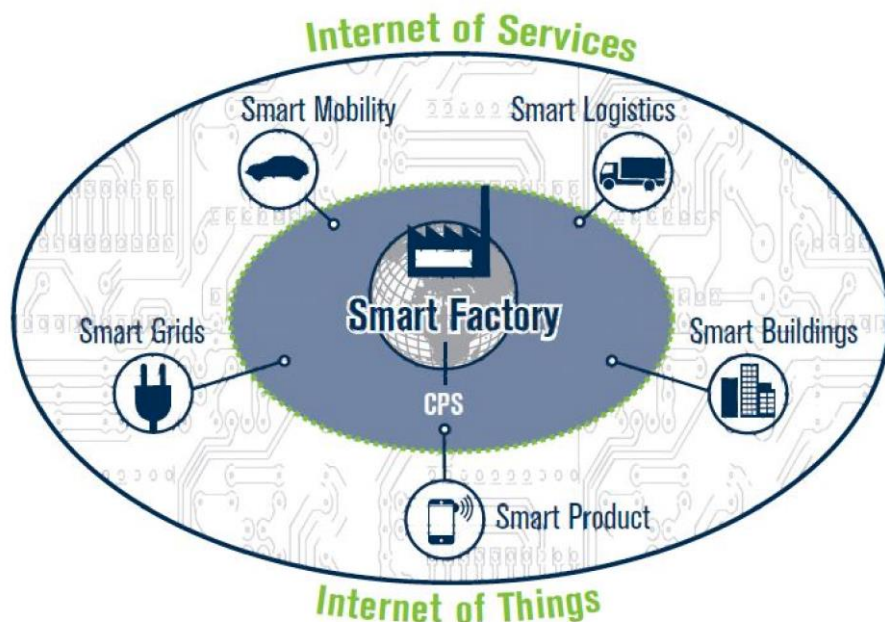

Figure 2 - Smart factory aspects [16].

Smart Plant as a term used consistently in the industry but has several different names, U – Factory, The Factory of Things, Intelligent Factory of the Future and Smart Manufacturing [18]. The Smart Factory is in many ways the end goal of Industry 4.0, it represents taking the

step from traditional automation to a more flexible, dynamic and connected system. The term Smart Factory describes an environment where machines and equipment are able to improve and optimize processes. The core value in a Smart Plant is all about the connection of production, information and communication technologies [16]. This is accomplished by integrating physical assets with cyber-physical systems so that the machines are connected by the internet.

The trends and driving forces involved in the rapid development surrounding Industry 4.0 can be connected to these emerging technologies. Industry 4.0 is in many ways connected with real time communication and the use of sensors are becoming more cost-effective way to control the assets. The increased smartness and intelligence different use cases are a key enabler in the Industry 4.0 development [19]. How these trends and driving forces are connected as part of a greater whole can be illustrated in the figure below.

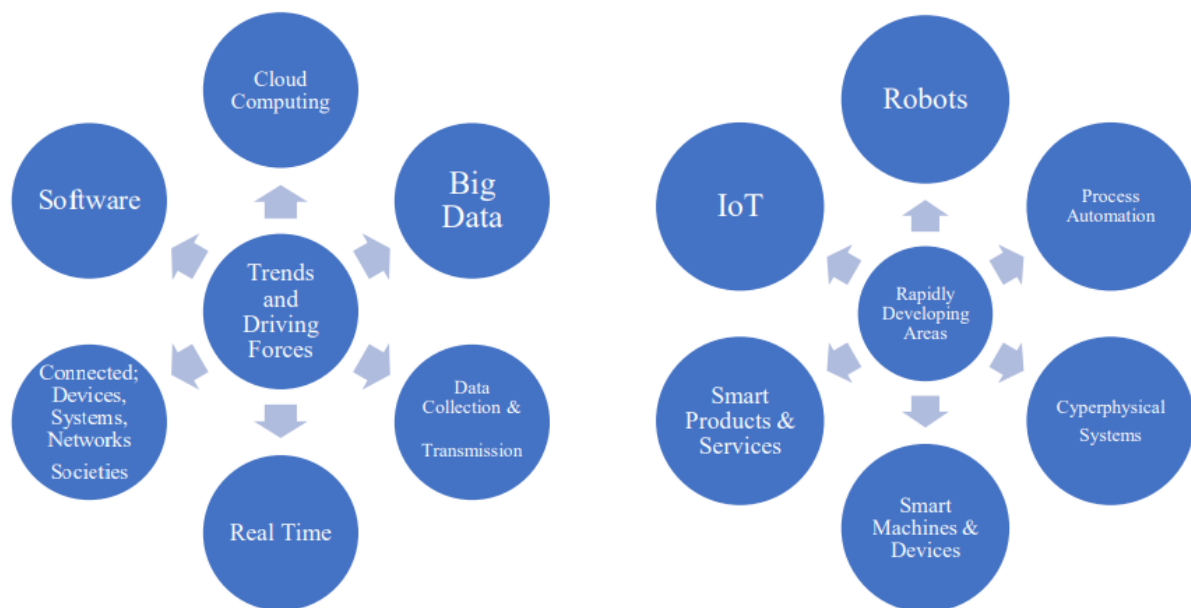

Figure 3 - Overview of Trends & Driving forces and Rapidly Developing Areas [20].

2.1.5 Industry 4.0 and Maintenance

In many ways Industry 4.0 is revolutionizing the way maintenance is done and perceived today. Predictive maintenance is emerging as one of the most applicable technologies with potential use cases in multiple industries. This period of digital transformation brings forth an era of fast paced change and new challenges [21].

The main goal of implementing Industry 4.0 solutions in maintenance is to be able to best balance the maintenance management with focus on quality and production schedule. Today a rough estimate is that companies perform approximate 50% more preventive maintenance than required according to ARC Advisory Group’s Enterprise Asset Management and Field Service Management Market Study [22]. Although these estimates hardly apply for all industries it gives a rough estimate of the potential available.

The main challenges affiliated with Industry 4.0 and implementation in regard to maintenance is the lack of standards for implementing new solutions and systems. One standard that has emerged is the DIN SPEC 91345:2016-04, which describes a standard architectural model for Industry 4.0 implementation. While still in development it still provides us with some means to break down complex systems and processes into understandable parts. In this way all the different parties involved in the Industry 4.0 development can understand each other. An illustration of the RAMI 4.0 hierarchy developed in DIN SPEC 91345:2016-04 [23].

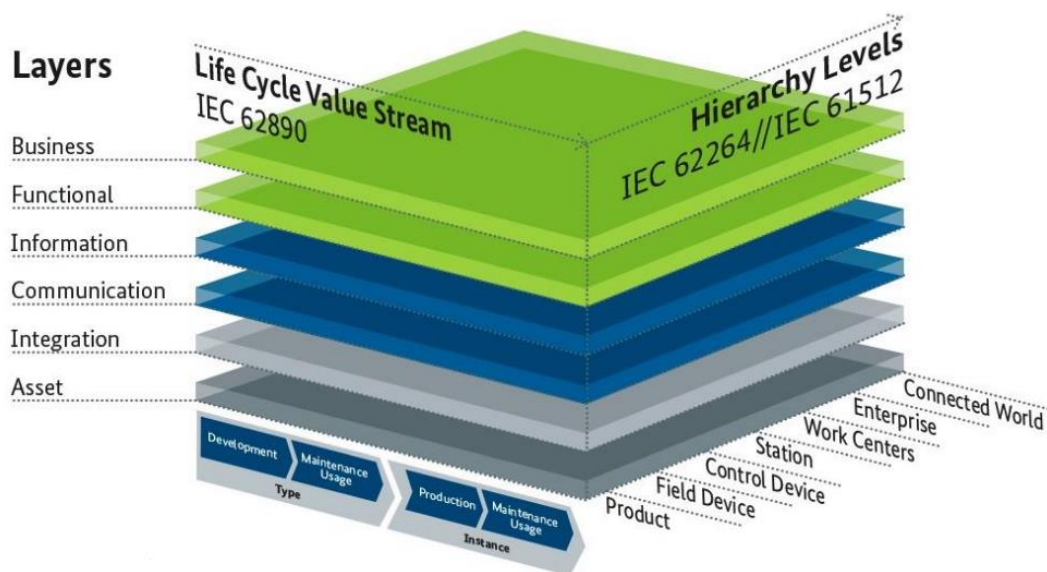

Figure 4 – RAMI 4.0 hierarchy [23].

This RAMI 4.0 hierarchy starts at the asset level and ends at an organizational business level and consists of three different dimensional axis. The different axis is designed to break down complex processes and combines elements and components from IT in a layer with life cycle. The hierarchy can be described as a map for showing us how to approach the issue of Industry 4.0 in a sensible manner. The RAMI 4.0 roadmap can be laid out in a more global manner as illustrated in the figure bellow [23]:

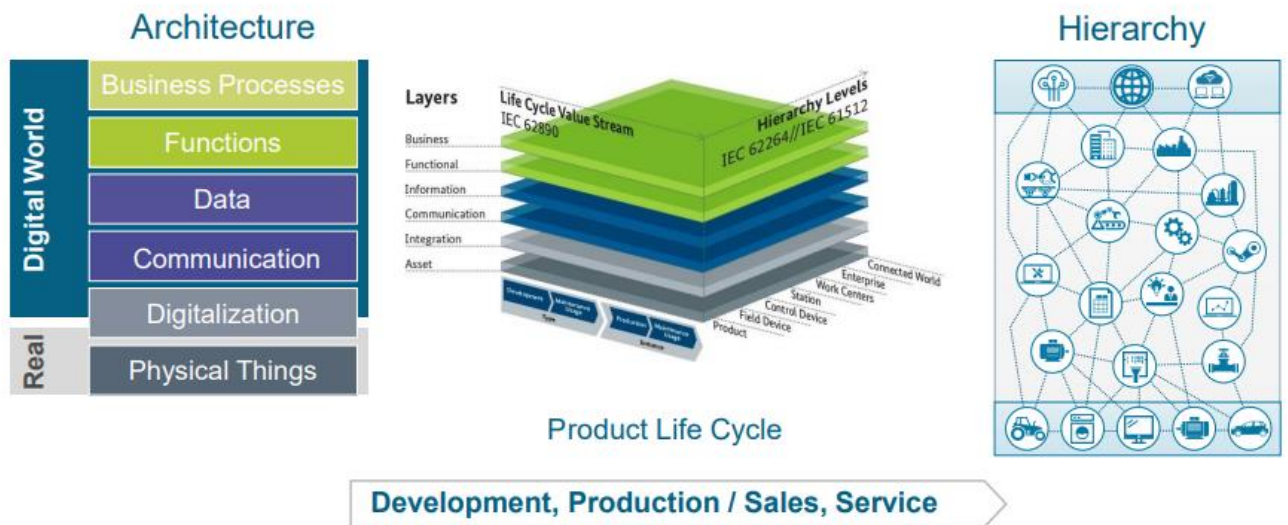

Figure 5 - Global map of RAMI 4.0 [23].

The first axis describes the hierarchy in the factory and in what way the different systems and machines communicate. This hierarchy compared to the more rigid hierarchy under Industry 3.0 is flexible and the functions and interactions are spread throughout the network. The second axis describes the product life cycle following the product from the first idea to the scrapyards. Firstly, concerned with the development and planned maintenance usage and then secondly with the production and the maintenance of the asset. The last axis is the main architectural layout ranging from the physical assets to organizational business level.

Using this architecture, we will be able to develop our chosen case study from a maintenance asset related field device level to a more digital organizational layer. This is mainly done through the development and implementation of an administration interface that acts as an interpreter between the physical asset and Industry 4.0 [23]. To be able to implement a predictive maintenance program this paper will utilize a modified cyber-physical system model. This cyber-physical system architecture model is based on the CPS 5C's which is illustrated in the figure below.

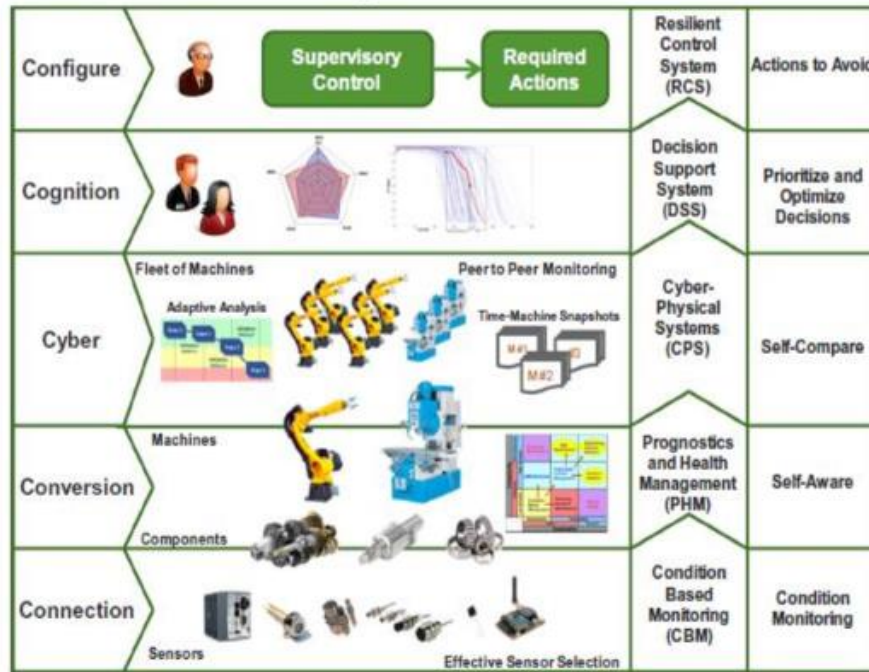

Figure 6 - Cyber-physical system 5C components [24].

Using this architecture as a framework this thesis will build an intelligent maintenance model for further development of a predictive maintenance program. This layered architecture gives us a baseline to develop a process tailored to the case study at Kverneland Group.

To be able to develop a factory from Industry 3.0 to 4.0 this thesis proposes:

1. Physical layer: A physical asset must be chosen to implement a solution on.
2. Configuration layer: The asset must have a control system for the avoidance of unwanted situations and established systems for the collection of data.
3. Cognition layer: The data collected need to be prioritized and delivered into the correct cyber space for more efficient computation.
4. Cyber layer: The gathered amount of data is sorted and pre-processed using signal analytics software.
5. Conversion layer: The analysed data is converted into results that are relevant for maintenance decision support along with diagnostics and predictions of the machine health.
6. Connection layer: The end result from the cyber-physical space is then delivered in the form of intelligence that are feed into the application(software).

These six-steps will form the framework for the development of a predictive maintenance program based on Industry 4.0 solutions for the case study. To be able to use this framework it is important to understand the system in question.

2.1.6 Systems thinking

Systems thinking is the first step in developing a predictive maintenance program and is used to gain an understanding of the selected system and its engineering aspects. To understand how a system works one can use management models to break down the system into manageable parts. This is especially useful in a maintenance perspective as the ability to break down a mechanical system is critical.

The goal by using this technique is to establish a conceptual model for the operations and monitoring of the selected case study. We can do this by employing the IDEF0 method to conceptualize and break down systems into blocks with their associated inputs and outputs. The IDEF0 method stands for Integration Definition and refers to a model used for modelling decisions, actions and activities of an organization or system was established in. The figure below gives an illustration of how such a diagram way look [25].

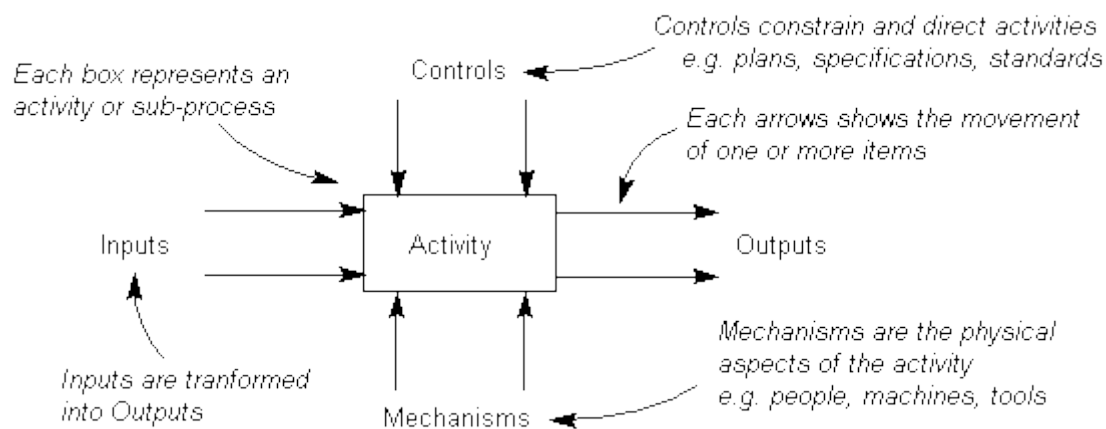

Figure 7 - IDEF0 description [25].

IDEF0 models are often created as the first step towards starting a new system development effort. When developing a new system, the need for making sound and reasonable decisions based on discovered parameters.

2.1.7 Pugh Matrix

The Pugh Matrix is a decision-making tool made by Professor Stuart Pugh at the University of Strathclyde. This tool is used for comparison between a number of design options and illustration of which one is the better choice with regards to specified criteria. The process is comprised of four steps [26]:

1. Start by clearly identifying the selection criteria most relevant for the needs identified. This is often a mix between design options and design requirements.
2. Identify a point of reference. This is often done by using a baseline design or in some cases using the value 0.
3. Compare each option against the baseline or base value for all the identified criteria.
4. Summarize and evaluate the results, in some cases a hybrid solution of different designs could be an option.

An example of a Pugh Matrix can be seen in the figure below.

Criteria	Baseline	Alternative Solution		
	Current Solution	Alternative 1	Alternative 2	Alternative 3
Feasibility	5	1	1	1
Cost	4	-1	-1	0
Long Term Benefit	1	0	-1	1
Maintainability	3	0	0	-1
Availability of Resources	2	1	0	-1
Sum of all Positives		7	5	6
Sum of all Negatives		4	5	5
Sum of all Neutrals		0	0	0
Total		3	0	1

Figure 8 - Example Pugh Matrix [27].

The results from such a matrix are then evaluated towards the reference solution to enable decision making support. In this thesis the matrix will enable the quantification of attributes to illustrate the better choice between monitoring scenarios.

2.2 Maintenance

Machines in use will always be subject to wear and a certain need of maintenance. Historically maintenance has been performed after a machine is stopped or is damaged and unable to perform according to specifications. The process of identifying the failure and finding the damaged parts would then be initiated and replaced, this is called corrective maintenance. Several of the parts that lead to breakdowns are consumables that wear naturally by the applied strain on the machine. Using this information, it is possible to define fixed maintenance intervals based on how long these components last, this is called preventive maintenance. As the industrial production depend on a greater degree of availability to deliver their product on time it is desirable that machines do not break down at the same time and that maintenance is performed at an efficient time [28]. This maintenance strategy is called predictive maintenance and is based on the need for maintenance before breakdown. This is mainly done by using condition-based monitoring to predict the health of the asset [29].

Today it is common to use a software called Computerized Maintenance Management System (CMMS) for maintenance planning. Which the main purpose of is to understand how the machines in a system are managed and then develop schedules for preventive maintenance. There is several different CMMS software with different applications and benefits, but this thesis will not investigate them further [29].

The main challenges with maintenance management today are tied to the balancing of maintenance management, with an increased demand for production uptime and quality as the main factors. Along with the recent technological development the future factory will need to restructure companies and change how their organizations are working. The organization will have to view the production and maintenance as two sides of the same coin leading towards a more profitable and sustainable manufacturing environment [30] [16].

Big data is also at the forefront of new challenges, being called the next big thing tied to productivity, innovation and competition [16]. The technological advances made has enabled companies to collect vast unfiltered amounts of data without knowing it usefulness or relevance. The data collected may not individually be of any use but combined may offer patterns and trends that may be useful for several different applications. The potential of this

data and Industry 4.0 enables companies today to develop indicators for maintenance software and by doing such establish a predictive maintenance programme.

Maintenance is the key to push life cycle cost down and to ensure to longevity of equipment. There are several different maintenance strategies, and these have their own individual pros and cons which is investigated further in chapter 2.3.

2.3 Maintenance programs

Table 1 – Overview of maintenance programs [31].

Strategy	Traits
Corrective Maintenance (CM)	<ul style="list-style-type: none"> • No planning • Ideal for low priority equipment
Preventive Maintenance (PM)	<ul style="list-style-type: none"> • Defined schedules • Based on statistics • Ideal for medium priority equipment
Predictive Maintenance (PdM)	<ul style="list-style-type: none"> • Based on actual condition of equipment • Condition monitoring is required • Ideal for high priority equipment
Proactive Maintenance (Pro-M)	<ul style="list-style-type: none"> • Based on Preventive Maintenance and Predictive Maintenance • Focuses on identifying root causes for failure and resolving them

Historically, the maintenance of equipment and systems have evolved alongside the technological development [5]. Today the process of defining the most successful maintenance strategy for each equipment is called Reliability-Centered Maintenance (RCM). This strategy is implemented to optimize the maintenance program in regard to the failure modes and criticality analysis. The historical development of maintenance is tied to the technological development, seen from a historical perspective the timeline is illustrated in the figure below.

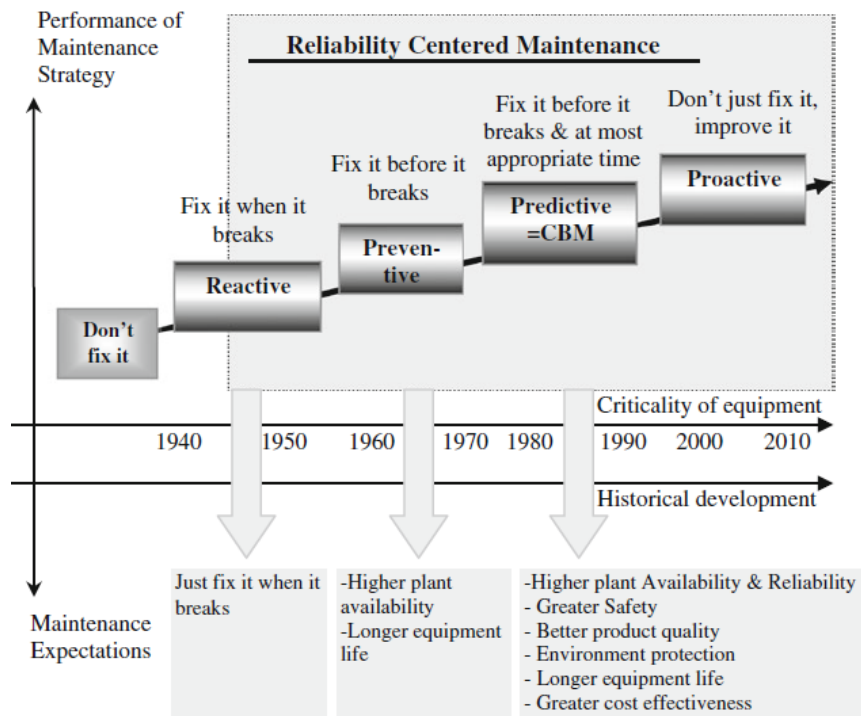

Figure 9 - Historical development of maintenance [5].

2.3.1 Corrective Maintenance (CM)

Corrective maintenance is a technique used when the equipment in question does not have a critical effect on HSE or the further operations of the system. The maintenance is carried out after a failure is occurred and the goal is to bring the asset back to operational function [32]. This philosophy is based upon the belief that the costs accrued by downtime and repairs are lower than the cost of implementing a maintenance program, which leads to CM being only useful for non-critical systems.

Table 2 – Overview of Corrective Maintenance

Corrective Maintenance	
Pros	Cons
<ul style="list-style-type: none"> • No planning: All downtime is unplanned, and replacements does not need to be available • Complete use time: The components will ha a maximum lifetime and will not be replaced with useful life remaining. 	<ul style="list-style-type: none"> • Financial loss: Downtime is proportional with loss of production and revenue • Unstable production: The downtime might cause bad customer relations as they would want their product in due time. The customer is the end point of the value chain and essential to the making of profit. • Missed learning: No time to implement counter measures to avoid problems in the future.

2.3.2 Preventive Maintenance (PM)

Preventive maintenance is the preferred maintenance program when the cost of maintenance is lower than the cost of a breakdown and the goal of the program is to minimize downtime. This program includes systematic inspection of the asset in order to detect problems and failures in order to correct them. It is based upon historical data and prior knowledge of how and when the components in the asset breaks down. This data combined with a risk and time-based approach is used to schedule inspections and maintenance. The schedule is determined and based on prior breakdown history, component specifications and operator recommendations [33].

Table 3 –Overview of Preventive Maintenance

Preventive Maintenance	
Pro	Cons
<ul style="list-style-type: none"> • Minimizing of unplanned downtime as parts are changed before failure. • In general, the life expectancy of critical equipment is increased as the integrity of the asset is maintained. • Availability of spare parts and service personnel due to scheduling. • The yearly maintenance costs are very predictable. 	<ul style="list-style-type: none"> • Non complete use time: Parts are replaced with lifetime remaining. • Cost of maintenance: Scheduling and planning increases the cost related to maintenance. • Human factors: When performing replacements humans will always be a part of the process, and with them comes risk of mistakes. • Machine operation: The machines operational time might vary due variations in production, and such the inspection and maintenance routines might always not be optimally suited

2.3.3 Predictive Maintenance (PdM)

Predictive Maintenance in regards to the Industry 4.0 paradigm is a program used for preventing failure in assets by monitoring, collecting and analysing data to predict and identify failures before they take place. The main goal of PdM is to maximize uptime and the maintenance strategy is used when the failure of the asset has a critical consequence in regard to operations or HSE.

A key concept in PdM systems is the term Remaining Useful Life (RUL). This term a prediction of the time remaining until a machine failure that requires a repair or replacement. Maintenance teams are able to use this prediction to evaluate and optimize the maintenance schedule. The inputs needed for establishing this model is mainly dependent on the data available and is mainly indicators of the condition of the machine [28].

In general, maintenance is performed when certain indicators regarding the assets health signals that the condition is deteriorating and a certain “threshold” is reached. These indicators are gained through various condition monitoring techniques, ranging from physical inspection to real – time sensor data. Some of the most used condition monitoring techniques are described in chapter 2.4.

One can observe PdM in different levels of maturity and a framework for identifying these where developed in a report by PwC [34]. These four levels can be described as:

Level:1 Visual inspections

Level 2: Instrument inspections and measurements

Level 3: Real time condition monitoring

Level 4: Continuous real time condition monitoring where decisions are made with regards to predictive techniques like regression analysis

Where Level 4 is in some cases described as PdM 4.0 or Prescriptive due to its close entanglement with Industry 4.0 [35]. Predictive maintenance is dependent on data, the different levels exist in a Big Data framework and is illustrated in the figure below.

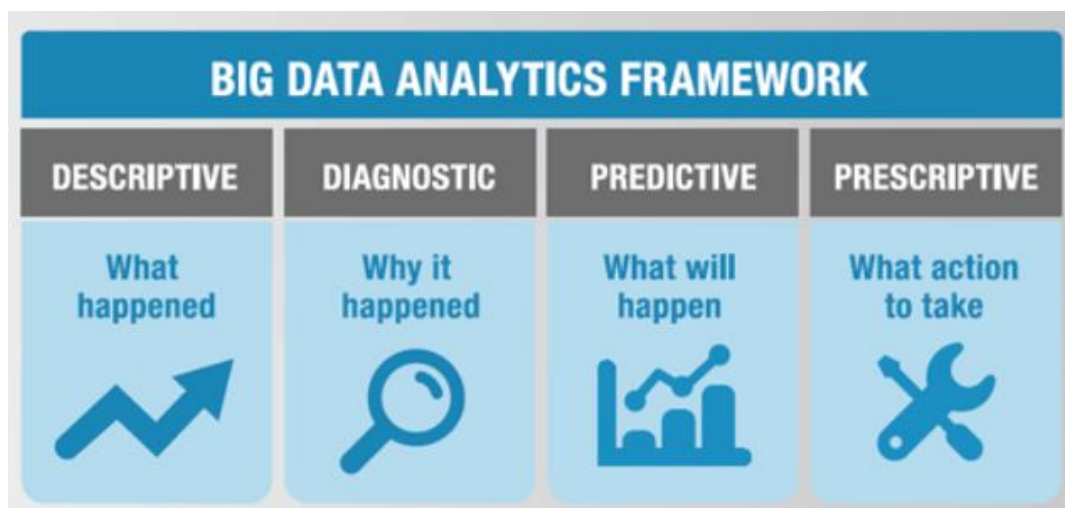

Figure 10 – Framework for Prescriptive maintenance [35].

This latest maturity level revolves around predicting failures and developing the most effective preventive measure by using analytic techniques on big data of elements related to performance of the asset. This kind of predictive maintenance involves exploiting new technological

advancements within artificial intelligence, machine learning and pattern recognition as the basis of decision making. For what this thesis is concerned the focus will be on predictive maintenance as a way to utilize a Remaining Useful Lifetime (RUL) model to evaluate the state and remaining lifetime of the machine.

Table 4 – Overview of Predictive Maintenance [35].

Predictive Maintenance	
Pro	Con
<ul style="list-style-type: none"> • The real time information of the health of the asset helps to maintain maximum uptime. • Availability of spare parts and service personnel due to scheduling and advance notice of failures. • Close to complete use time of parts as they are replaced close to the failure time. • Less expenses as the cost related to unplanned downtime and ineffective maintenance. • In general, the life expectancy of critical equipment is increased as the integrity of the asset is maintained. 	<ul style="list-style-type: none"> • High costs: Establishing a Condition Monitoring system can involve high capital and operational expenses. • Less predictable maintenance cost: The replacement when needed philosophy is less predictable and will give more short-term cost. • Need for change: The organization will have to make a big transition from a schedule-based program to more flexible real-time solution program.

2.3.4 Proactive Maintenance (Pro-M)

Proactive Maintenance is in many ways a combination of maintenance and continuous improvement. Preventive and predictive maintenance strategies influence proactive maintenance and is in many ways more of an approach than a strategy. The approach is mainly based upon a preventive maintenance system where it rather works toward eliminating the root causes of failure. The proactive approach helps enable organizations to perform maintenance only when it is necessary. It is based upon gathered maintenance data and requires one to address more systematic elements of the maintenance program rather than the machines

themselves. The data collection condition monitoring is an important aspect of proactive maintenance programs as they need to track data and trends to predict fault scenarios [36].

The main objectives of the proactive maintenance program are to [36]:

- Identify the root causes for failure
- Resolve potential failure scenarios before they manifest
- Extend the Remaining Useful Lifetime (RUL)

Table 5 - Proactive maintenance [35] [36].

Proactive Maintenance	
Pro	Con
<ul style="list-style-type: none"> • The real time information of the health of the asset helps to maintain maximum uptime. • Availability of spare parts and service personnel due to scheduling and advance notice of failures. • Close to complete use time of parts as they are replaced close to the failure time. • Less expenses as the cost related to unplanned downtime and ineffective maintenance. If optimized, it should provide the lowest maintenance in general due to the improvement of “weak” links in the organization. • In general, the life expectancy of critical equipment is increased as the integrity of the asset is maintained. • The most optimized maintenance program. 	<ul style="list-style-type: none"> • High costs: Establishing a Condition Monitoring system can involve high capital and operational expenses. • Less predictable maintenance cost: The replacement when needed philosophy is less predictable and will give more short-term cost. • Need for change: The organization will have to make a big transition from a schedule-based program to more flexible real-time solution program. • Difficulty: Out of all the different options proactive maintenance requires the most skill and competency to be effectively implemented.

2.4 Condition Monitoring

The implementation of condition monitoring is crucial to establish a reliable predictive maintenance program. Condition monitoring is the process of monitoring parameters in machines, mainly to identify changes that can be identified as developing fault scenarios. The following flowchart describes the condition monitoring procedures and is related to ISO 17359 [37]. This procedure will be used throughout this thesis to evaluate our chosen system.

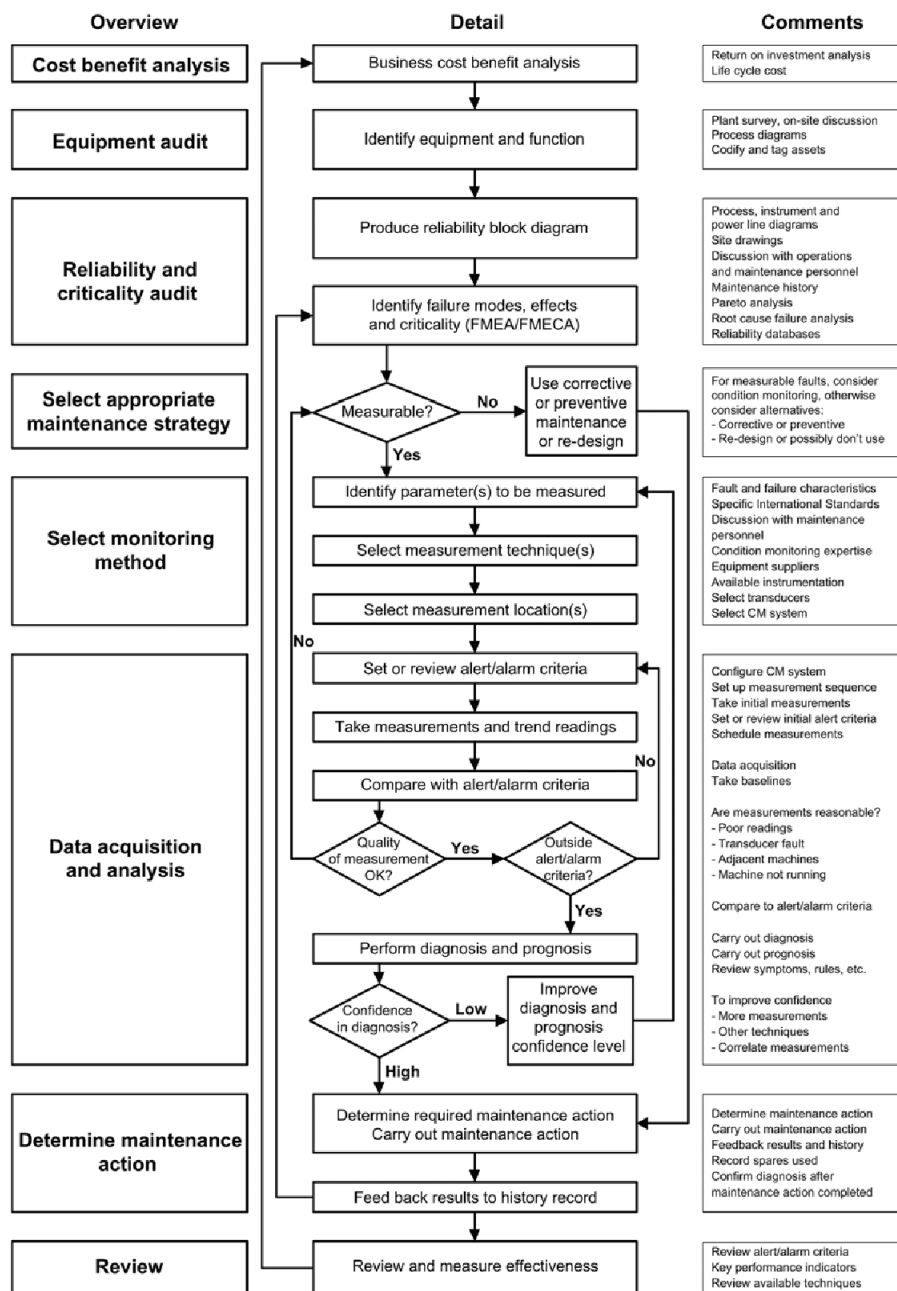

Figure 11 – Condition monitoring and diagnostics of machines [37].

One of the most critical aspects of establishing a condition-based maintenance and asset health prognosis is having a standardized approach to the process. The first step towards establishing a condition monitoring based maintenance programme needs to be establishing a framework for evaluating the systems involved. Using Systems thinking we are able to gain an understanding necessary for further progress. The next step would be to identify what equipment we want to focus on and then perform a failure analysis on it so that relevant condition monitoring techniques can be evaluated. Lastly, the failures identified will be considered towards condition monitoring techniques most suitable for the specific fault.

2.4.1 Failure analysis

A critical component of deciding on any maintenance program consists of performing a failure analysis. After reviewing the selected production line and the system within, we focus on the potential failure modes and criticality aspects that it contains. Some common failure analysis techniques are: Failure Modes, Effects and Criticality Analysis (FMECA), Hazard & Operability Analysis (HAZOP), Fault Tree Analysis (FTA) and Cause-Consequence Analysis. In this report we will perform a Failure Mode and Criticality Analysis (FMECA) on the system to identify the potential failure modes and their criticality. This is done as it's the most comprehensive and detailed analysis and will provide the most accurate results [38] [39].

FMECA is a qualitative methodology which focus on identification and analyzation of failures. This process requires the identification of certain information regarding the system in question [40]:

- Components – What subcomponents are included in the system
- Function – How does each component work
- Failures – How does the components fail
- Effects of Failure – What are the effects of failure in each component and its effect on other components
- Causes of Failure – What are the causes for failure in each scenario
- Current Control – What types of control measures are implemented
- Recommended Actions – What is the recommended action for averting failure

These data are then plotted into the FMECA diagram as shown in the example below. Where different failure modes, effects, causes and control measures are plotted to gain a overview over the most critical.

POTENTIAL FAILURE MODE AND EFFECTS ANALYSIS
Front Door L.H.

FMEA Type _____ FMEA Number 1450

Item 1.1.1 - Front Door L.H. Process Responsibility Body Engineering Page 1 of 1

Model Year(s)/Vehicle(s) 20XX/Lion 4dr/Wagon Key Date 3/10/2015 Prepared By J. Ford - X6521 - Assy Ops

Core Team A. Tate Body Engr, J. Smith - OC, R. James - Production, J. Jones - Maintenance FMEA Date (Orig.) 3/10/2015 (Rev) 3/21/2015

Name / Function Requirements	Potential Failure Mode	Potential Effect(s) of Failure	SEVt	Classification	Potential Cause(s) of Failure	OCCI	Current Process Controls (Prevention)	Current Process Controls (Detection)	DETI	RPNt	Recommended Action(s)	Responsibility & Planned Completion Date	Action Results					
													Actions Taken & Actual Completion Date	SEVt	OCCr	DETr	RPNr	
1.1.1 - Front Door L.H.																		
Op. 70 Manual application of wax inside door/ cover inner door, lower surfaces with wax to specification thickness.	Insufficient wax coverage over specified surface	Allows integrity breach of inner door panel. Corroded interior lower door panels. Deteriorated life of door leading to: - Unsatisfactory appearance due to rust through paint over time - Impaired function of interior door hardware	7		Manually inserted spray head not inserted far enough	8		Visual check each hour - 1/shift for film thickness (depth meter) and coverage.	5	280	Add positive depth stop to sprayer.	Mfg Engr - 3/10/2003	Stop added, sprayer checked on line.	7	2	5	70	
												Automate spraying.	Mfg Engr - 3/10/2003	Rejected due to complexity of different doors on same line.				
												Use Design of Experiments (DOE) on viscosity vs. temperature vs. pressure.	Mfg Engr - 3/10/2003	Temp and press limits were determined and limit controls have been installed - control charts show process is in control Cpk = 1.85.	1	5	35	
					Spray head clogged- Viscosity too high- Temperature too low- Pressure too low.	5	Test spray pattern at start-up and after idle periods, and preventive maintenance program to clean heads.	Visual check each hour - 1/shift for film thickness (depth meter) and coverage.	5	175								
					Spray head deformed due to impact	2	Preventive maintenance program to maintain heads.	Visual check each hour - 1/shift for film thickness (depth meter) and coverage.	5	70								

Figure 12 - Example of an FMECA table [41].

This analysis involves a method to quantify the risk associated with the potential failures identified in the process. This risk evaluation method is based upon assigning Risk Priority Numbers (RPN) to each event and this is done by; Rating the severity of each failure, rating the likelihood, rating the likelihood of detection of each failure and then lastly calculating the RPN, with values ranging from 1 (Best) to 1000 (worst) [41].

The severity in this case is a subjective estimate based on the severity of the effect failure has. This factor is based upon interviews with key operators and maintenance engineers at Kverneland Group. An illustration of how these severities are defined is included in the table below, with a range from 1 (best) to 10 (worst).

Table 6 - Severity description [41].

Rating	Description
1	Parameters are within operational limits and adjustments can be made during standard maintenance procedures.
2	Parameters are not within operational limits and adjustments need to be made to ensure no downtime or unacceptable quality.
3	Downtime of up to 6 hours
4	Downtime between 6 – 12 hours
5	Downtime between 12 - 24 hours
6	Downtime between 1-7 days
7	Downtime between 1-2 weeks
8	Downtime between 2-6 weeks
9	Downtime between 6-12 weeks
10	HSE Complications

The occurrence is a numerical factor assigned to the likelihood that a failure will occur, and it is typically based on known data or in some cases the lack of it. The rate of failure is ranged from 1 (best) to 10 (worst) and is illustrated in the figure below.

Table 7 - Occurrence description [41].

Rating	Description
1	Mean Time Between Failure of failure is greater than 20000 hours
2	Mean Time Between Failure of 10001 to 20000 hours
3	Mean Time Between Failure of 6001 to 10000 hours
4	Mean Time Between Failure of 3001 to 6000 hours
5	Mean Time Between Failure of 2001 to 3000 hours
6	Mean Time Between Failure of 1001 to 2000 hours
7	Mean Time Between Failure of 401 to 1000 hours
8	Mean Time Between Failure of 101 to 400 hours
9	Mean Time Between Failure of 11 to 100 hours
10	Mean Time Between Failure of 1 to 10 hours

Detection is given a numerical estimate based on information gathered based on Kverneland Groups ability to prevent or detect failure. An example of these ratings is given in the table below.

Table 8 - Detection description [41].

Rating	Description
1	Control methods will always detect a potential failure mode
2	Control methods will most likely detect a potential failure mode
3	Control methods will be likely to detect a potential failure mode
4	Control methods will have a moderate-high likelihood to detect a potential failure mode
5	Control methods will have a moderate likelihood to detect a potential failure mode
6	Control methods will have a low likelihood to detect a potential failure mode
7	Control methods will have a very low likelihood to detect a potential failure mode
8	Control methods will have a remote likelihood to detect a potential failure mode
9	Control methods will have a very remote likelihood to detect a potential failure mode
10	Control methods will not be able to detect a potential failure mode

This is then used to prioritize and evaluate the severity of failures. Combined these data are used to prioritize design improvements or plan maintenance and repairs.

$$\text{RPN} = \text{Severity} \times \text{Occurrence} \times \text{Detection}$$

Equation 1 - Risk Priority Number [41].

This equation is used in coherence with an FMECA table to be able to make a decision on which equipment should be prioritized for further evaluation.

2.4.2 Condition Monitoring Techniques

Condition monitoring is a mayor part in PdM and the use of monitoring tools allows for the schedule of maintenance and planning of actions to avoid failure [42]. There are several industrial requirements for condition monitoring in machines. Firstly, the monitoring technique has to use non-intrusive measurements so that the system is not compromised. Secondly, the technique must enable early detection so that one can reduce the cost associated. Lastly, it is recommended to use multiple technologies to get a complete and thorough assessment of the health of the asset [43]. Some of the different technologies used in condition monitoring is illustrated in the figure below.

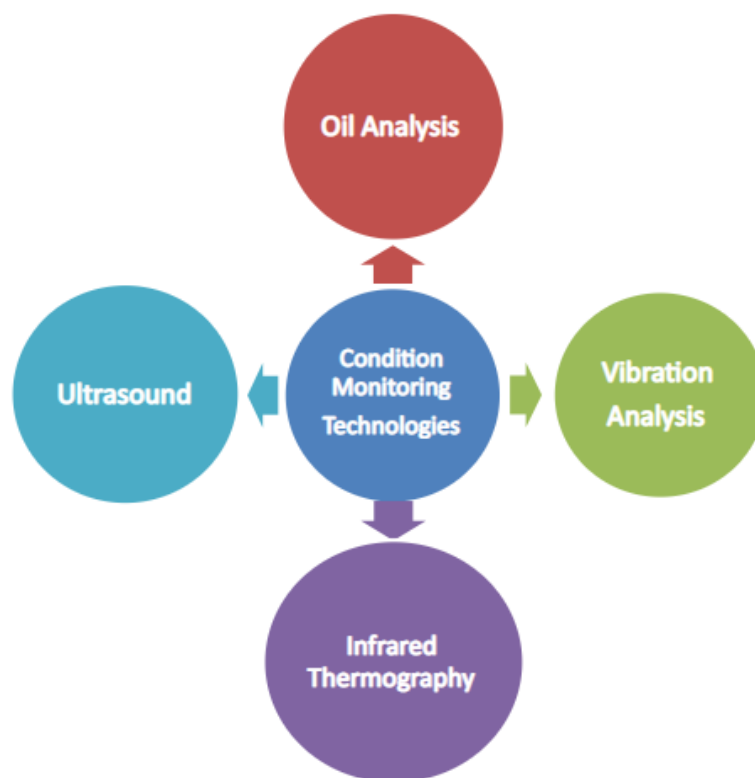
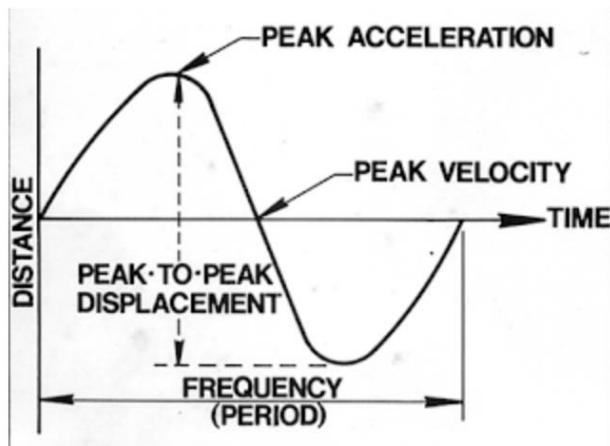

Figure 13 - Condition monitoring technologies [44]

Condition monitoring is one of the best tools for exploiting the potential for enhancement in the reliability of systems. This potential be increased uptime, reduction of damage and improving efficiency. The different condition monitoring techniques use dedicated sensor and data analysis tools to be able to characterize variations in operating conditions. As this thesis revolves around rotating mechanical machinery the most effective condition monitoring technique is vibration monitoring and this will be further investigated in the next chapter [45].

2.4.3 Vibration monitoring

All mechanical machinery vibrates and can be described as the periodic back-and-forth motion of particles of an elastic body or medium. These vibrations can in their entirety be translated into movement in the orthogonal direction and rotation around the x, y and z axis [46]. These vibrations are measured in three different factors which are mentioned in the figure below.



- Peak to peak displacement is the total distance traveled from one extreme limit to the other extreme limit
- Velocity is zero at top and bottom because weight has come to a stop. It is maximum at neutral position
- Acceleration is maximum at top and bottom where weight has come to a stop and must accelerate to pick up velocity

Figure 14 – The different aspects of vibration [46].

The forces driving vibration depend on the force, direction and frequency generated by the machine or equipment in question. These forces are dependent on the state and condition of the machine and the prior knowledge/data available allows one to diagnose or prognose a fault. Some key points can be identified as [46]:

- Unfiltered overall amplitude indicates the condition of the asset
- Displacement amplitude is not a direct indicator of vibration severity unless it is combined with frequency.
- Velocity takes advantage of the function of both displacement and frequency
- Unfiltered velocity measurement is the best overall indicator of vibration severity

Table 9 - Explanations of Displacement, Velocity and Acceleration [46].

Vibration measurements	Description	Formula
Displacement	The position of an object	$d = x = A \sin(\omega t)$
Velocity	How rapidly the object is changing its position with time	$v = \frac{dx}{dt} = A\omega \sin(\omega t + 90^\circ)$
Acceleration	How fast the velocity is changing with time	$a = \frac{dv}{dt} = A\omega^2 \sin(\omega t + 180^\circ)$

Vibrations in a machine are most often not that simple to interpret. These can be from many different malfunctions and the total vibration is the sum of all the vibrations. It is therefore important to know what types of frequencies that are relevant to monitor for different types of machinery. The table below gives a rough estimate of what types of monitoring parameters are most useful for different frequencies.

Table 10 - Overview of useful monitoring parameters [46].

Frequency	Monitoring parameter
Less than 18 000 CPM	Displacement
18 000 to 180 000 CPM	Velocity
Higher than 180 000 CPM	Acceleration

Vibrations can exist in several ways, the simplest being a simple harmonic motion. This motion exists in one direction and is most commonly described as “a single degree of freedom spring-mass system”. The figure below illustrates how this may look like and how the correlating relations are between amplitude (A), time (t) and displacement (y) [47].

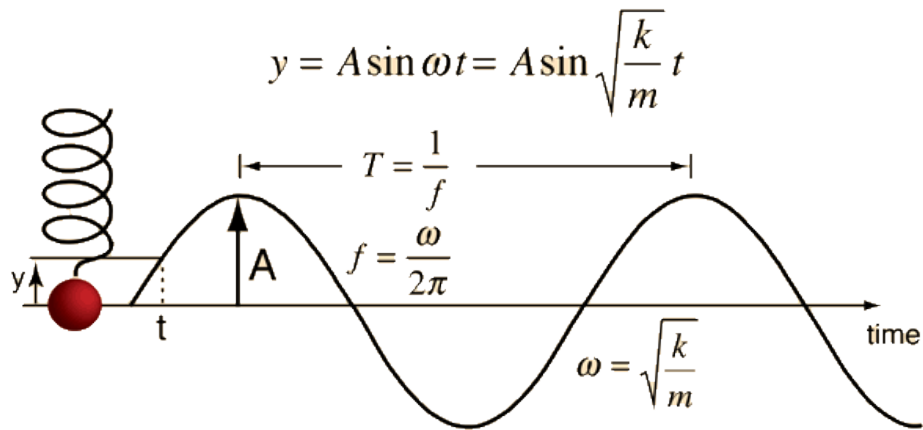

Figure 15 - Illustration of simple harmonic motion [47].

While in mechanical systems there may often be more than one frequency and force acting on the system and thus the following vibration will be more complex. This can be seen in the figure below.

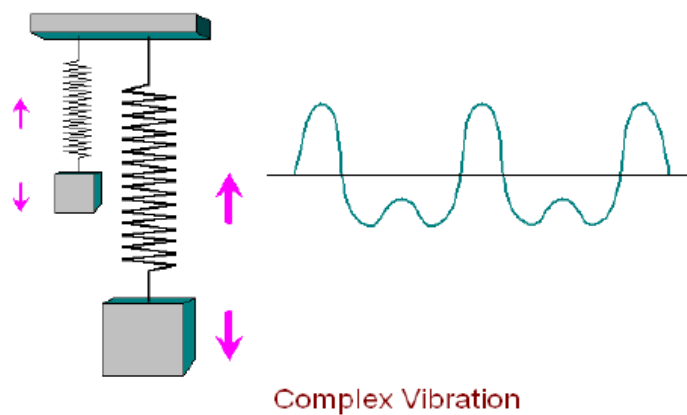

Figure 16 - Illustration of complex vibration [48].

Any mechanical system can be illustrated as a set of springs, masses and dampers and will vibrate at a unique natural frequency. This natural frequency is dependent on the strength of the energy source and the absorption/dampening in the system [49].

$$F_n = \frac{1}{2\pi} \sqrt{\frac{k}{m}}$$

Equation 2 - Natural frequency formula [49].

- F_n = natural frequency of an undamped spring-mass system
- k = The spring constant or stiffness of the material
- m = The mass of the object

Vibration monitoring is the key to identification of asset issues early and predict future events and is mainly done by use of accelerometers which measure changes in amplitude, frequency and intensity in the machine [43].

Vibrations are made by mechanical energy and to be able to analyse them they need to be converted into an electrical signal. This is done so that the signal can be easily analysed and measured. The most commonly used method of doing this is by using vibration transducers. A vibration transducer is a device that is able to convert one form of energy into another. The three most common transducers are [50]:

- Non-contact Displacement Transducer
- Seismic Velocity Transducer
- Piezoelectric Accelerometer

The latter of the three are the most commonly used today and is widely accepted as the best choice when it comes to vibration monitoring. This is mainly because of the following advantages [50]:

- Wide range of frequencies supported
- Compact and sensitive sensor
- No moving parts i.e. no possibility for wear
- Acceleration measured can be used to provide velocity and displacement

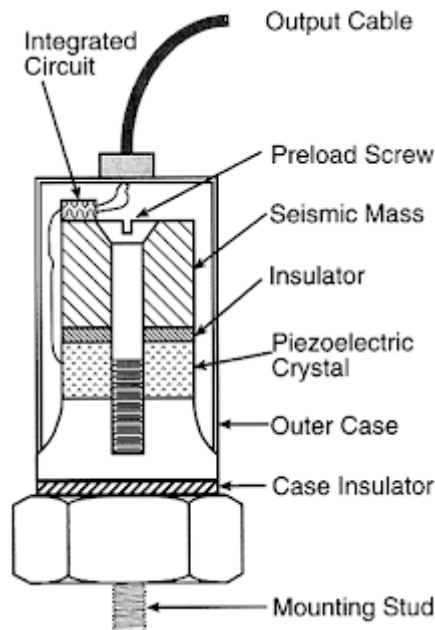

Figure 17 - Piezoelectric Accelerometer [50]

The Piezoelectric sensors as illustrated in the figure above generate an electric charge that is proportional to the vibration acceleration measured. This sensor requires no external energy and is not capable of emitting a true direct current (DC) response and this need to be converted. This processing is done by a digital converter (ADC) to be able to analyse the spectrum data obtained by the sensor [50].

2.4.4 Fault diagnosis with vibration analysis

The use of vibration analysis on data gathered by sensors is a process of looking for changes in the frequency of the machine. The vibration in any object will always correlate to the physical state of the machine and can be used to gain information of the health of the machine. The most important outputs of vibration analysis are the diagnosis and prognosis, what is wrong and how long will it last [51].

The wave form generated by the vibration sensors are limited in the ways it can be analysed, it is most common to perform a frequency analysis to get around these limitations. This is called a spectrum analysis and is produced by the transformation of a signal from the time domain to a signal from the frequency domain [50]. This frequency domain is then used as a baseline for the machine which is the “normal” operating state. The health of the machine can then be evaluated by the changes in this base frequency spectrum. An illustration of how some common faults can be seen in a spectrum is illustrated in the figure below:

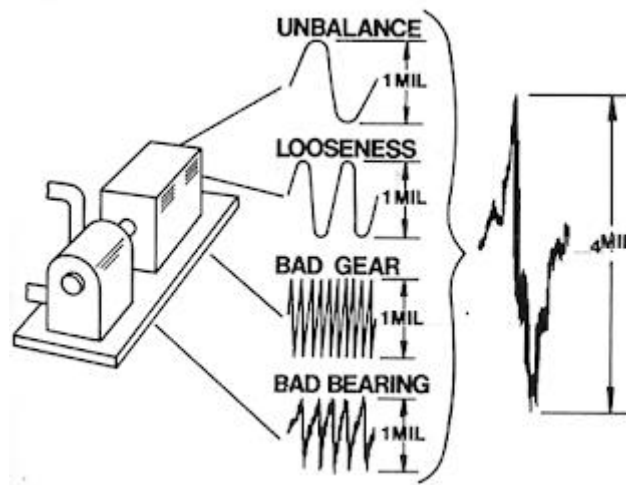

Figure 18 - Different vibration fault spectrums [46].

Machine failures can appear in many forms, each one having different vibrational frequencies. Some of the most common machine failures that are detectable by vibration analysis is [52]:

- Misalignment
- Unbalance
- Mechanical looseness
- Bent shaft
- Rolling element bearing defects
- Gear defects
- Shaft cracks
- Cavitation
- Electrical faults

These specific failures can be detected in a spectrum plot based on their frequency and amplitude and the figures below show how these would look in relation to their CPM (cycles per minute).

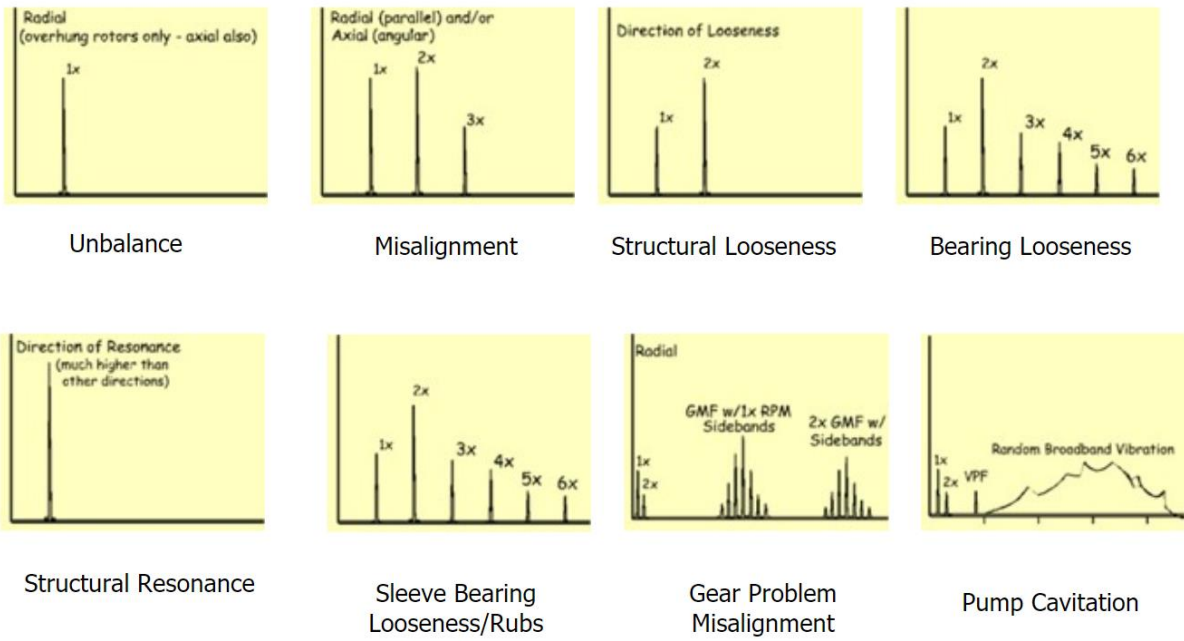
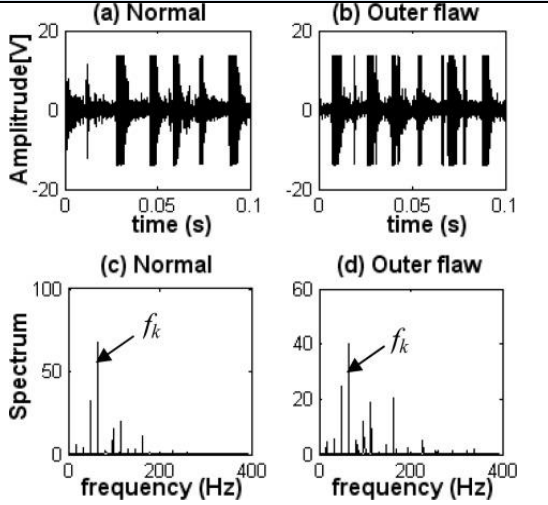
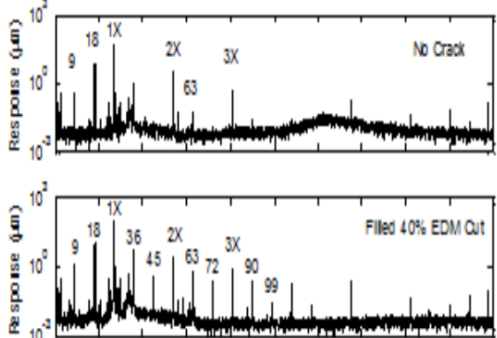

Figure 19 Failure scenarios and their spectrum plots [44].

The most relevant machine failures for this thesis have been illustrated in the table below. These failures are not the only ones that occur but is by far the most frequent and tied to the most critical equipment.

Table 11 - Relevant machine faults tied to the case study [53] [54].

Fault scenario	Description	Fault analysis
<p>Rolling element bearing defects</p>	<p>As the bearings wears the bearing will produce vibration components at different non-synchronous frequencies. This is due to the bearing's geometry and design. The exact values of these frequencies are provided by the manufacturer of the bearings.</p>	 <p>The fault analysis for rolling element bearing defects is shown in four subplots:</p> <ul style="list-style-type: none"> (a) Normal: Time-domain plot of Amplitude [M] vs time (s) showing a regular, periodic waveform. (b) Outer flaw: Time-domain plot of Amplitude [M] vs time (s) showing a waveform with irregular, non-synchronous peaks. (c) Normal: Frequency spectrum plot of Spectrum vs frequency (Hz) showing a dominant peak at f_k. (d) Outer flaw: Frequency spectrum plot of Spectrum vs frequency (Hz) showing a dominant peak at f_k and several smaller, non-synchronous peaks.
<p>Shaft crack</p>	<p>As the shaft suffers fatigue and wear the shaft will experience a loss of stiffness and structural integrity due to the loss of mass. The frequencies that the vibrations will trigger on the vibration spectrum will be a 2x CMP frequency.</p>	 <p>The shaft crack analysis is shown in two frequency response plots:</p> <ul style="list-style-type: none"> Top plot: Response (μm) vs frequency (Hz) for a shaft with "No Crack". The spectrum shows peaks at 9, 18, 1X, 2X, 3X, and 63 Hz. Bottom plot: Response (μm) vs frequency (Hz) for a shaft with "Filled 40% EDM Cut". The spectrum shows peaks at 9, 18, 1X, 36, 45, 63, 72, 90, and 99 Hz.

3. Case study

The agricultural equipment industry involves the production and design of machinery that is used in either farming or agriculture. There are many different types of machines / equipment in this segment, ranging from hand tools to ploughs and tractors. The machinery which is the main focus for this thesis is used in the production process at Kverneland Groups factory in Klepp.

The case study chosen is selected on recommendation from Professor Jayantha Prasanna Liyanage, PhD at the University in Stavanger. Having identified Kverneland Group as an organization in change and with a willingness for self-improvement in this time of technological development.

3.1 Kverneland Gruppen

Kverneland Group is a global leading supplier of agricultural equipment. Founded in 1879 by Ole Gabriel Kverneland it was originally a forge made for producing scythes. Later on, they slowly transitioned into making small ploughs while still being a family owned company. In 1983 the company was listed on the stock exchange and is today a supplier of a broad variety of agricultural equipment. Today they are owned by the Japanese company Kubota which is one of the largest producers of agricultural equipment worldwide. Today the Kverneland brand stands for unparalleled quality and reliability [55].



Figure 20 - Kverneland factory at Klepp, Norway [56].

The main focus for this thesis will be their factory in Klepp, Norway and is shown in the figure above. This factory is over 51 000 m² and houses approximate 500 personnel with a production capacity of around 300 ploughs a year [55].

3.2 Organization

After being established in 1879 Kverneland Group has grown from a small family business to one of the world's largest supplier of agricultural equipment. Employing around 2500 in locations like Norway, Denmark, France, Germany, Netherlands, Italy, Russia and Kina.

The company and their employees are devoted to their slogan which is “But they still need lunch”. People around the world will always need food and there has to be somebody producing that food. Meaning that as long as there is a need for food, there will always be a need for farmers and agricultural equipment. Their vision is to be a leading industrial supplier of intelligent and effective equipment that contribute to precision in agriculture and keeping the food production going in this growing world population [55].

3.3 Production Process

The production factory at Klepp consists of six interconnected production halls and a separate assembly hall. The combined factory area consists of 51 000 square meters and contain a variety of equipment of machinery. The six production halls are labelled from A0 to A5 and contribute towards producing different agricultural equipment as well as spare parts. The factory at Klepp produces ploughs, topple trenchers and different assorted attachments.



Figure 21 - Main critical production steps.

The main critical production steps are summarized in the figure above. Starting with the processing and cutting of the raw materials in hall A5 and ending with the main assembly in hall AH. The layout of the factory is as illustrated in the figure below:

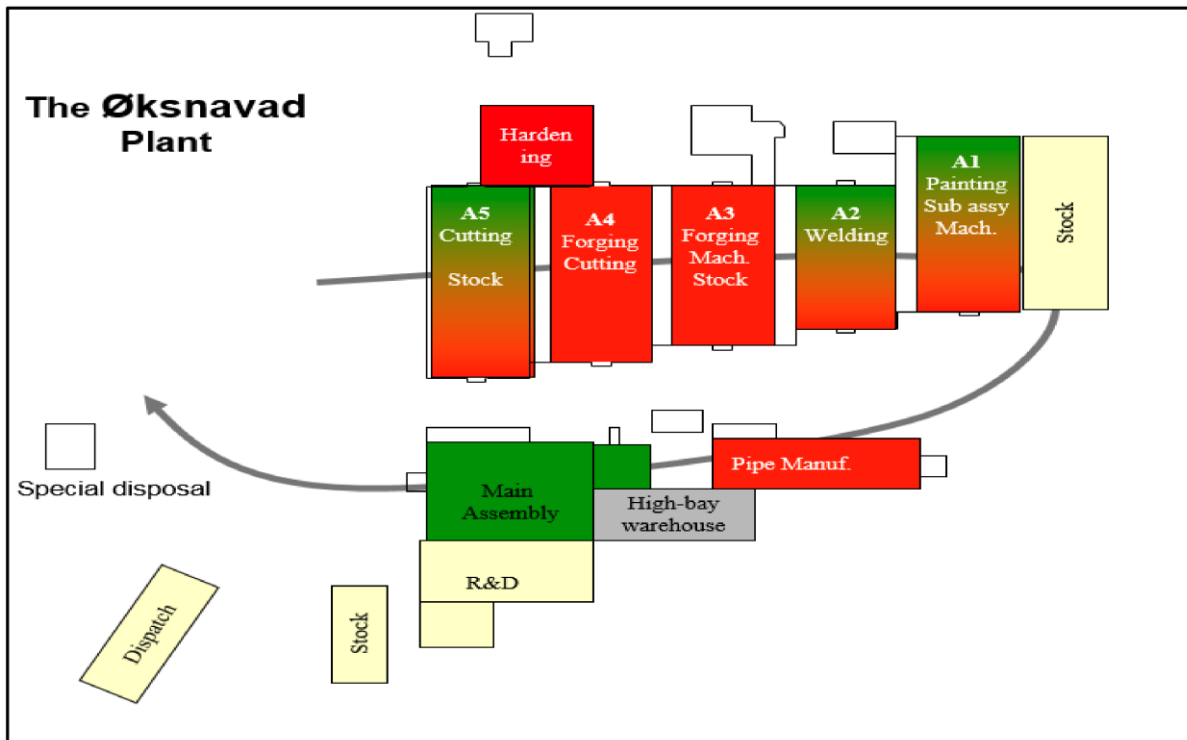

Figure 22 - Factory overview [56].

- A0 -The last hall from the right is where the main stock of produced parts and semi-assembled components are stored.
- A1 – The fifth hall in the figure is where the main painting and sub assembly takes place. There is also some minor machining done.
- A2 – The fourth hall is where the main welding takes place, both by operators and automated machinery.
- A3 – The third hall in the figure is where forging and machining takes place. This is also the place the work pieces are hardened, which is one of the most important processes with regard to the quality and reliability of the end product
- A4 – The second hall in the figure is where the main forging and cutting of material takes place. This hall also includes the most equipment relevant to this thesis, the rotating mechanical forge presses.
- A5 – The first hall in the figure is where the raw materials are delivered in the form of metal rolls. These materials are then processed further into sheet metal to be used in the other parts of the production process.
- AH – Main assembly hall where the ploughs and other products are completed and made ready for shipping and use.

The fourth hall, A4, is identified by Kverneland as the one containing most critical equipment based on value created. A4 contain 7 of the top 10 most critical equipment, including the A300 which this thesis will focus on. The figure below illustrates the criticality evaluation done by Kverneland Group.

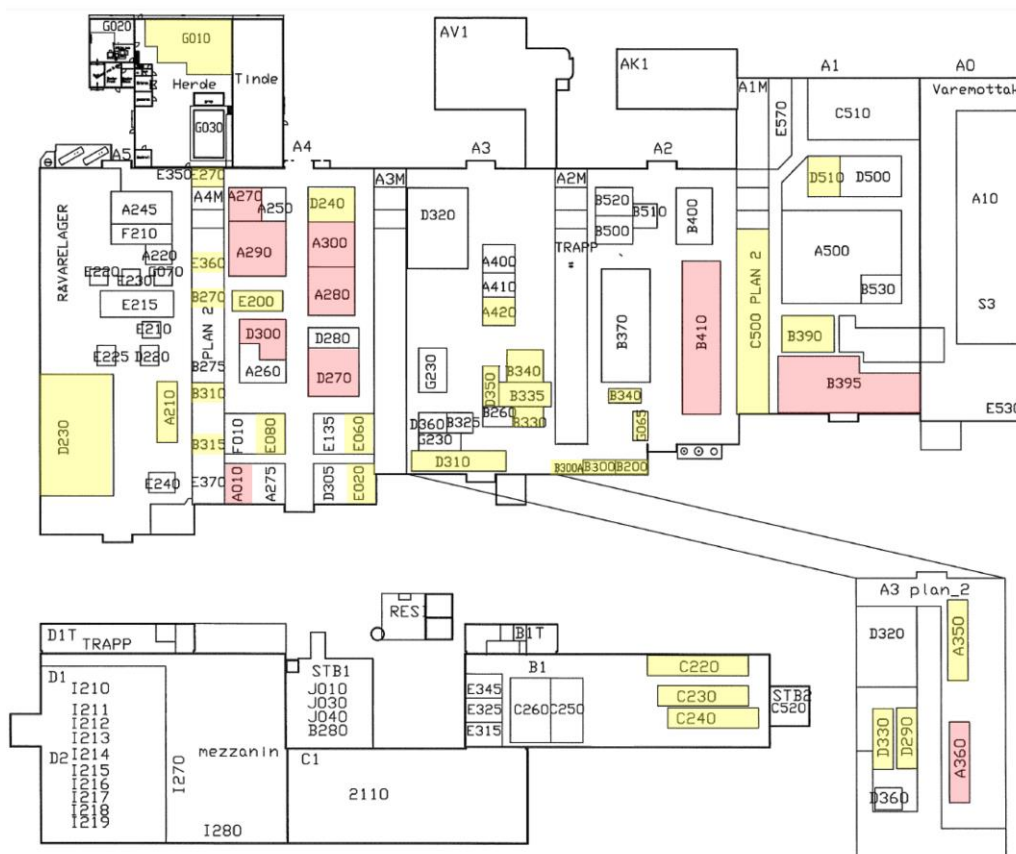

Figure 23 - Top 10 critical equipment at Kverneland factory at Klepp [56].

In this figure the red boxes illustrate the top 10 critical and value creating equipment, while the yellow boxes describes the top 10-30. This figure is developed by Kverneland Group in an effort to evaluate their production process and critical equipment.

3.4 Current maintenance program

The current maintenance program used at Kverneland Group is a mix between corrective and preventive maintenance and is coordinated through the Computerized Maintenance Management System (CMMS), Onix. In this maintenance management system over 3000 different machines are registered and over 1000 which has been scheduled with periodic maintenance or inspection tasks [57]. The consequence of the technological development and

stricter demands for profitability and downtime Kverneland Group has seen a need for improvement with regards to their CMMS, as the existing system is ill suited for such an extensive and diverse production process. The current planned maintenance tasks are developed and based upon the experiences and knowledge gained by Kverneland Group over time [57].

Kverneland Group's technical department which has the responsibility for maintenance at the factory consists of one technical manager, two mechanical engineers, two automation/electrical engineers and three maintenance engineers. This department is responsible for planning and following up on scheduled maintenance task and repairs.

The factory has one main maintenance period each year, in July, where the entire production is shut down to be able to perform major maintenance tasks. This period of two weeks is performed in the summer due to the warm weather and consequently warm production halls due to the main heat treatment and forging processes. During major maintenance operations many of the operations performed are done by consultants which are hired in advance to perform maintenance.

As the main production line at Kverneland Group lacks any form for process monitoring at their most critical equipment this is not used actively in their maintenance strategy. This is mainly due to the age of their machine park, the oldest being from the early 20th century. [57].

3.5 Pilot project

Seeing that their aging machine park lacks the necessary monitoring equipment to be able to implement any form for condition monitoring or predictive maintenance Kverneland Group has started a pilot project. This project's main purpose is to investigate the advantages of vibration analysis on the A300 – Hasenclever FPRN 300 mechanical forge press [57]. This machine press main task is to forge steel work pieces into different shapes. This machine is identified as one of the most critical in Kverneland Groups production process, and as one of the ones with the most maintenance cost.

Having very little experience with condition monitoring techniques IoT Solutions have been contracted to assist in this matter. The project is planned to consist of several phases where phase 1 will include vibration monitoring sensors, installation and a monitoring software. During this phase the most optimal sensor location will also be investigated. Phase 2 will be executed based on the success of phase 1 and consists of scaling up the solution to other critical equipment.

This pilot project is expected to be operational from May 2019 and this early phase 1 is expected to cost 40 000 NOK [57]. This cost covers installation cost and the required parts, in addition to this cost there is a software license and yearly fee. This software cost is covered by Enova (Governmental environmental funding organization) as this is a pilot project. The project is expected to deliver vibration monitoring and a working monitoring software called Wonderware. This software is owned by the Aveva which is a marked leader in HMI SCADA, industrial information, operation management and industrial automation software [58].

The main purpose with this pilot project is to investigate the scalability and feasibility towards their other critical equipment. Having no previous experience with this kind of condition monitoring this gives Kverneland Group an opportunity to learn and develop their competence within the area. This thesis will investigate the best potential strategy moving forward with this pilot project.

4. Analysis of A300

In this chapter we will evaluate and analyse the A300 mechanical forge press and demonstrate how a framework for a predictive maintenance strategy can be implemented on an organizational and machine level. This strategy is currently in development at Kverneland Group and this thesis will serve as a foundation to build further upon. With this in mind, the cost effectiveness of the implementation will be evaluated compared to a proposed offer by IOT Solutions. This will be done by comparing the cost of mitigating a failure to the cost of implementation. This analysis is based upon the information gathered in the literature study so that a strategic framework can be made. The data used in this case study is based mainly on interviews and observations made while working at Kverneland Group.

This chapter will include:

1. System analysis
2. Failure analysis
3. Development of a framework for predictive maintenance
4. Implementation strategy for predictive maintenance
5. Cost-benefit analysis

4.1 System analysis

The production line at Kverneland Group is an enormous process involving over 3000 different kinds of equipment and machines. Kverneland Group having identified the top 10 most critical assets wanted this thesis to focus on their A300 mechanical forge press. This is also considered the heart of the factory and produce the most critical parts. The machine press is an immense and complex machine and consists of several components and subsystems. The machine is in many ways a big hammer and anvil and is widely used in the production industry [57]. We will analyse the A300 and the different needs and stakeholders that are involved. Once the basic understanding of how the system works and what are the relevant parameters for operations and maintenance are established, we can begin to identify failure modes that can affect the system.

4.1.1 System boundary

As the production process involves several different machines it is important to define the boundary and scope of the selected system. We are mainly concerned with the A300 and its

direct production process, mainly forging of work pieces. The system boundary for the production process can be illustrated in the Systems of Systems figure below. This is defined as the boundary where the work product enters the A300 and until it leaves it.

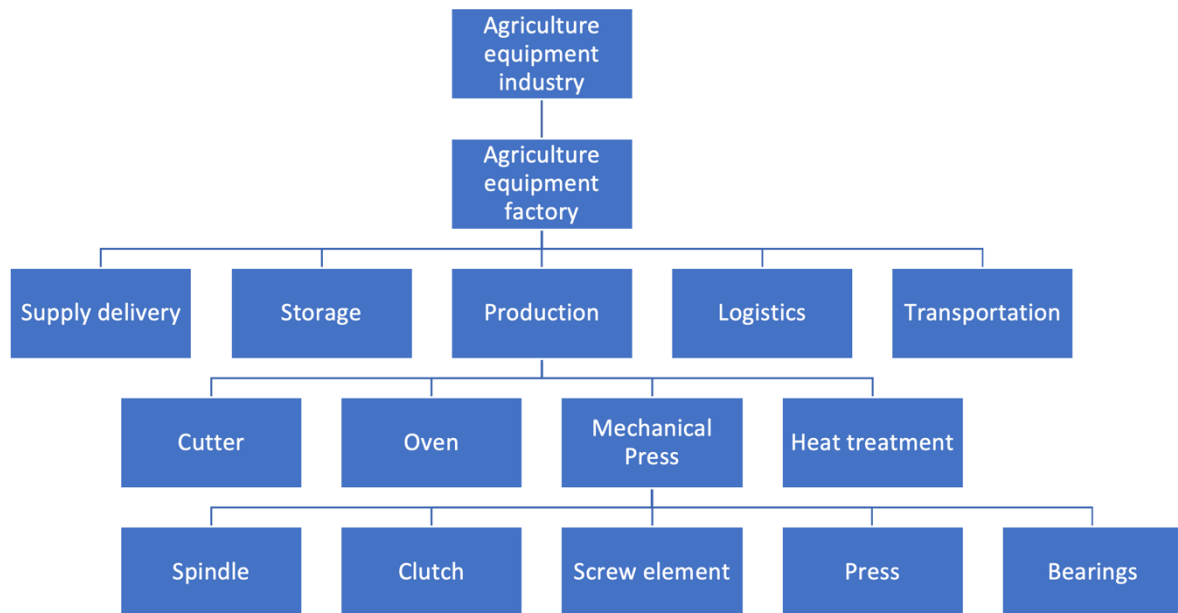

Figure 24 -System boundary.

4.1.2 Technical and Functional architecture

The focus on this thesis is on the A300 mechanical press more accurately it is an Hasenclever FPRN 300 and is used in the main production line at Kverneland Group’s factory at Klepp. This machine is mainly used for forging work pieces of steel into parts for agricultural equipment. This means this machine will have to be to apply a pressure on the work piece to be able to alter its form. This is made possible through rotating wheels that transfer power to a bandage wheel which in turn is rotating a screw that delivers the “hammer blow”. The figure below shows the technical architecture of the A300 and its relevant critical parts.

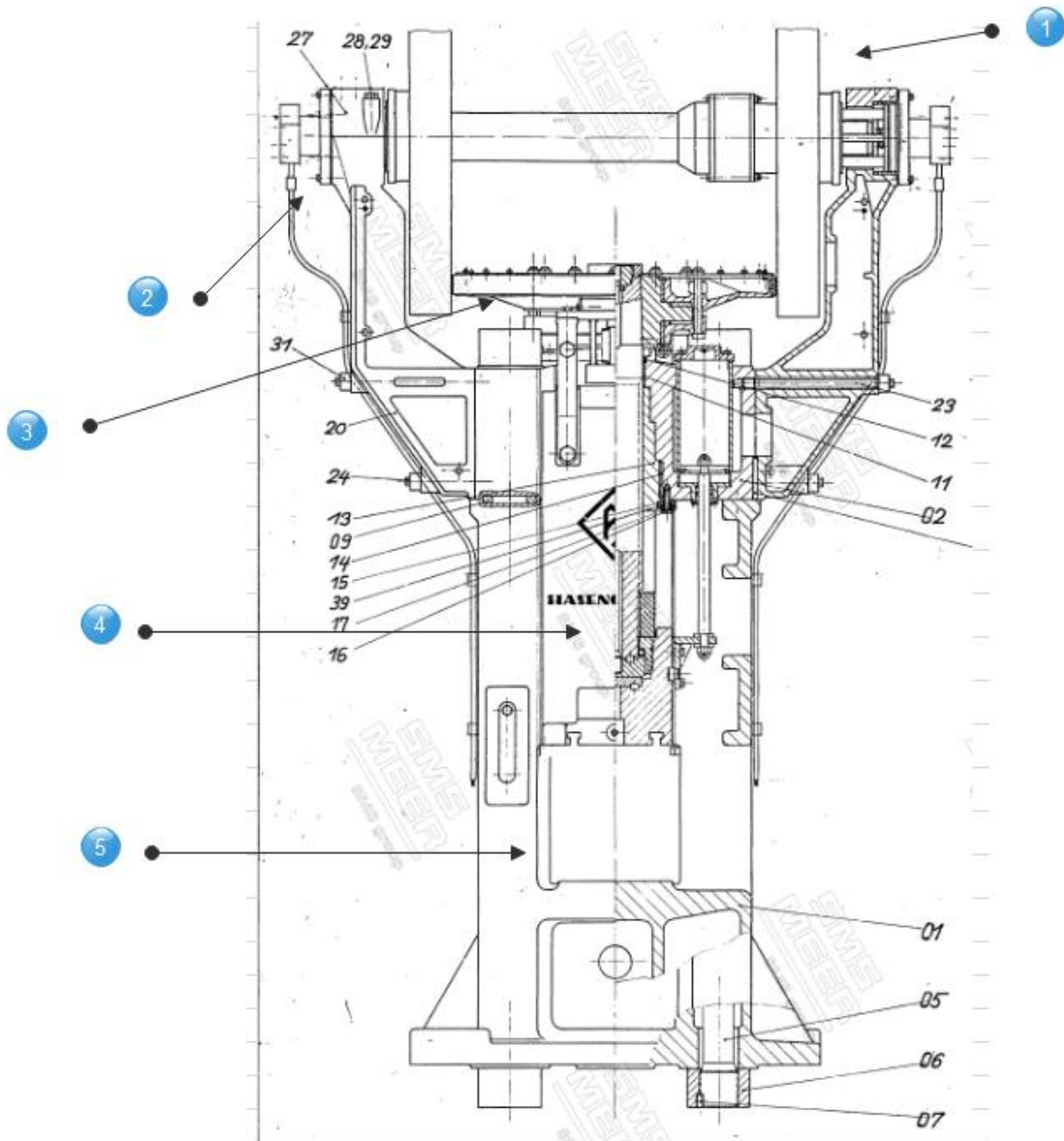

Figure 25 - Physical architecture of A300 [56].

1. Rotating wheels
2. Rolling bearing element
3. Bandage power delivery
4. Spindle-screw and nut
5. Hammer element

These illustrations are provided by Kverneland Group as the detailed schematics of the products is confidential work-product owned by another supplier.

The functional architecture of the system is evaluated by the critical components for production. This illustration tries to show the forging process work with focus on the critical components. The process can be broken down into four steps [57]:

1. The pre-heated work piece is placed into the machine by an automated arm.
2. A belt motor drives the rotating wheels.
3. The clutch engages the wheels which transfers power through the bandage wheel to the spindle-screw. The spindle-screw is forced down onto a nut and acts as a hammer on the work piece.
4. The work piece is removed from the machine by an automated arm after the spindle-screw is lifted up.

The IDEF0 diagram is then used to illustrate the inputs, processes and controls involved in every step of the production process. This gives us a more detailed view of the system compared to the System of System view. The figure below gives us a rough overview of the production process and the different parameters, controls, inputs and outputs.

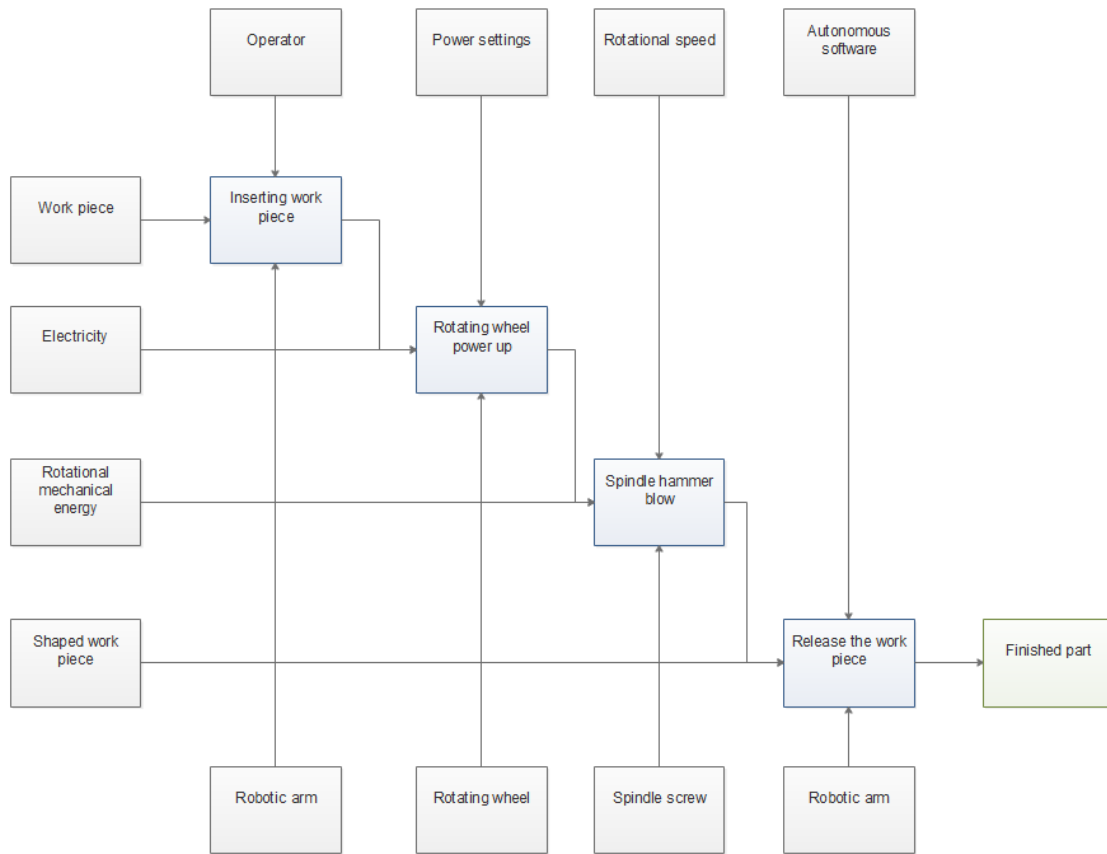

Figure 26 - IDEF0 diagram

4.1.3 Monitoring practice for A300

The operation of the A300 is done by one operator which operates the mechanical press. This operator performs real time monitoring of the of the machine in order to observe any potential failure scenarios. The A300 being an analogue machine with no process monitoring tools has no other monitoring possibilities other than in person monitoring and manually adjusting parameters tied to press strength. The different monitoring scenarios that are attached to the operations of the A300 is illustrated in the figure below.



Figure 27 – Monitoring use case scenarios.

Currently the process is monitored by one operator at the production line which is responsible for safely operating the A300. In the production hall he depends on his observation of the optical and sound parameters available to him. The operators control the amount of power the

machine uses and in some cases loss of power or effect of power can indicate a failure. The process monitoring system view is illustrated below.

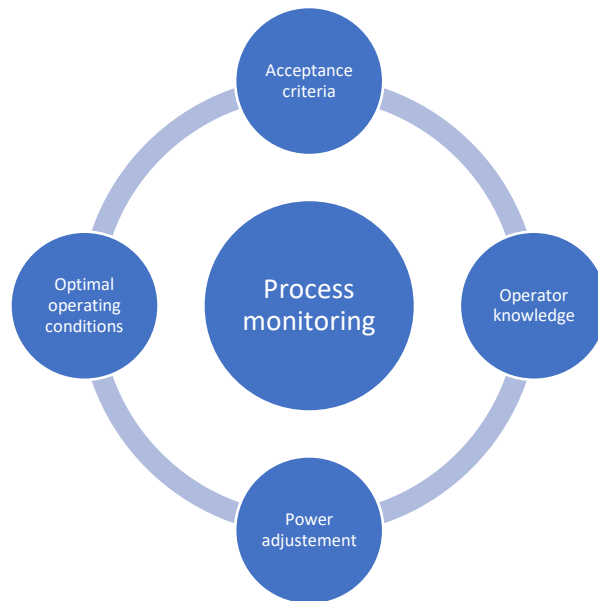

Figure 28 - Process monitoring system view.

Producing high performance parts require acute quality monitoring and each produced part is inspected by the operator for faults. For this process all the parameters tied to the production is monitored. This is illustrated in the system view below.



Figure 29 - Quality monitoring system view.

The task tied to machine health monitoring registered in the Computerized Maintenance Management System (CMMS) Onix, are mainly tied to refilling lubrication and oiling. These activities performed are mainly tied to preventive maintenance. Maintenance performed aside from scheduled tasks is mainly faults that are identified by operators due to deviations in production. In these cases, the operators have a reporting system with an inspection, correction and feedback process. This is illustrated in the systems view below.

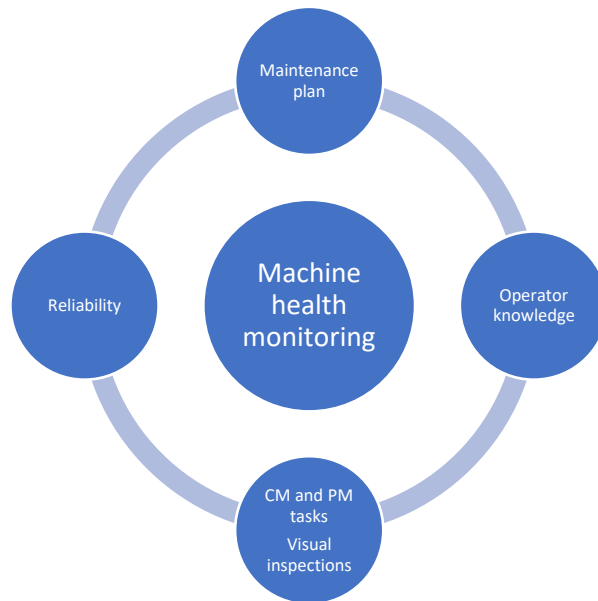

Figure 30 - Systems view of machine health monitoring.

Having identified the system boundaries along with the physical architecture and monitoring use case scenarios it is useful to look at the bigger picture and who is the real stakeholders for this asset.

4.1.4 System stakeholders

The machine system stakeholders are identified through observations and interviews with management, maintenance and operators at Kverneland Group. Their needs have been subsequently documented in the table below.

Table 12 - Stakeholder requirements and needs.

Stakeholder	Needs	Requirements	Criteria
Management	A reliable system that delivers when an order is ordered.	The maximum uptime for the least amount of resources.	Availability and Reliability
Operators	A system that is easy to use that delivers high quality products	Stable operations with predictive events	Stability and performance
Maintenance personnel	Reliable system that notifies when failure is imminent. Easy maintainability.	Ease of access and good communication with operator	Reliability
Quality and assembly personnel	A system that produces accurate and reliable products according to specifications	Correct specifications at a stable and reliable rate	Stability and accuracy

4.2 Failure analysis

Through discussions and interviews with the maintenance and management personnel at Kverneland Group, six scenarios have been identified where the A300 would experience a fault scenario that is critical to the production process [59].

1. Spindle-screw failure: The spindle screw might experience a cavitation and mechanical looseness between the screw and the nut. Leading to high wear on the slider element and bandage. Further lowering the quality of produced parts.
2. Drive belt: The belt driving the wheels could rip and subsequently leading to a production stop.
3. Bandage: The bandage element transferring power from the wheels to the spindle-screw could experience cavitation's which would lead to less power being delivered to the spindle-screw and further poor-quality of parts produced.

4. Motor bearing: The bearing between the motor and belt could experience rolling element bearing defects and would lead to the loss of power delivery to the wheels and a production stop. This can also lead to a motor failure.
5. Wheel bearing: The wheel bearing itself could experience rolling element bearing defects and this would lead to a loss of power delivery and a production stop.
6. Bandage bearing: The bandage bearing might experience rolling element bearing defects. This failure would lead to the bandage wheel not being able to stop in time. This would lead to the spindle-screw being displaced and thus breaking it along with the bandage wheel.

These scenarios are then further analysed in the FMECA analysis tool, which is covered in the next chapter, 4.2.1.

4.2.1 FMECA

Breaking down the established scenarios we investigate them further in a FMECA diagram. Each fault scenario is evaluated in collaboration with the maintenance engineer responsible for the machine presses at Kverneland Group [59].

Item / Function	Potential Failure Mode(s)	Potential Effect(s) of Failure	S e v e r i t y	Potential Cause(s)/ Mechanism(s) of Failure	P r o b a b i l i t y	Current Design Controls	D e t e r m i n e d	R P N
Spindle-screw	Cavitation on the spindle screw and mechanical looseness between spindle-screw and nut.	High wear on the slider element of the screw. Lower quality parts produced due to lessens striking power. Higher wear on badage due to increased strain.	9	General wear and operator fault	4	Visual inspections done by operator	8	288
Drivebelt	Riping of the belt	Loss of power and production stand still.	2	General wear	7	Visuel inspections during use	2	28
Bandage	Cavitations on the bandage	Less powered delivered to the spindle-screw and subsequently lessened quality of parts produced.	2	Wear	7	Visual inspections on predetermined intervals	2	28
Motor bearing	Rolling element bearing defects	Bearing faults might lead to motor failure and subsequently production stop	6	Wear	5	None	9	270
Wheel bearing	Rolling element bearing defects	Main power delivery from wheel to bandage stops and subsequently production stop	7	Wear	5	None	9	315
Bandage bearing	Rolling element bearing defects	Bandage wheel might not stop in time and can subsequently break the spindle-screw and bandagewheel.	8	Wear	3	None	8	192

Figure 31 – FMECA diagram [59].

From the analysis data obtained through the FMECA we observe that the wheel bearing has the highest RPN. This result establishes that the wheel bearing fault should be the scenario of interest in this regard.

4.2.2 Rotating wheel element

The driving force behind forging of the work piece is the rotating dual wheels on the top of the mechanical forge press. The main function behind these rotating wheels is to deliver rotational mechanical energy to the screw element which forges the work piece. The forging process depend on the wheels, bandage wheel and screw element to be accurately aligned to perform without any increased wear. This is due to the enormous forces that act upon the system when each blow is delivered in the forging process. The two-wheel elements rests upon two bearings that allow them to rotate freely. An illustration of the wheels, bearing and bandage wheel is shown in the figure below. The bearing which each of the wheels rests upon can be seen by the number 27 in the illustration.

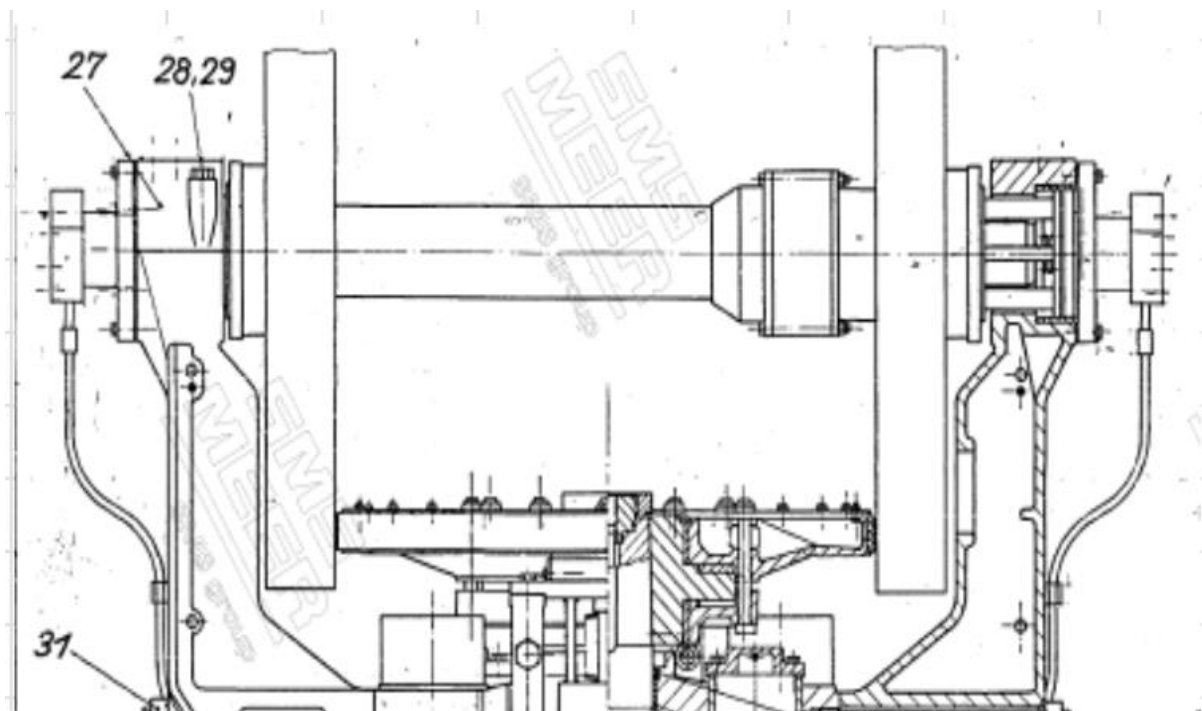

Figure 32- Close up on the top part of the machine press [56].

4.2.3 Rolling element bearing

Rolling element bearings are some of the most widely used mechanical parts in rotating machinery and is one of the most critical components [60]. The main function of a rolling element bearing is to support another moving machine element by permitting the relative motion between the bearing balls or rollers. Ball bearings in general can be divided into three different kinds, i.e. radial contact, angular contact and thrust contact. Radial ball bearings are

designed to support radial load, angular contact bearings are designed to support both radial and axial loads and the thrust bearings are designed to support axial load. In general roller bearings have a higher load capacity than ball bearings and are most used in situations with moderate speed and heavy-duty operations [61]. The illustrating below shows the technical architecture of the two most common bearing types.

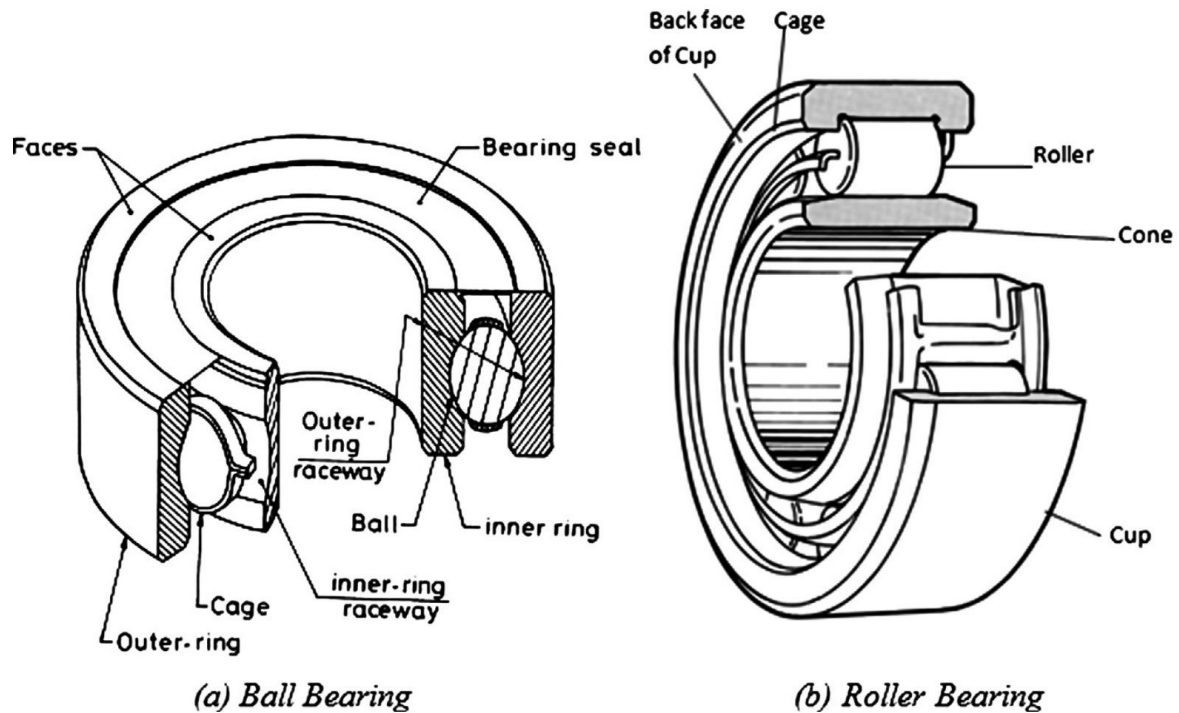

Figure 33 - Ball bearing and roller bearing [61].

The service life of bearings is either expressed as a total number of rotations or time before failure. The failures can occur either in the inner ring, outer ring or the rolling ball or roller element. These failures are caused by rolling fatigue due to the repeated cyclical stress [61].

4.2.4 Rolling bearing defects

Failures can propagate in many ways and in order to understand how to diagnose these we need to know how they are developed. The figure below illustrates how the different failures might look like and how they might appear.







	Failure	Cause	Sketches of failures
Flaking	Circumference on one side (Fig. 1)	Excessive axial load	 <p>Fig.1 Flaking along circumference on one side. (Deep Groove Ball Bearing)</p>
	Symmetrical flaking on each side (Fig. 2)	Inclined mounting, or shaft or housing not in the shape of a circle	
	Flaking on one side or flaking in the form of an oblique line on raceway surface of bearing ring on fixed side (Fig. 3)	Distortion of shaft, insufficient centering, bearings not installed on shaft at the correct angle	
	Partial flaking on thrust bearing	Eccentric mounting	
	Flaking found on part only	Contamination by foreign matter(s), flaws, initial stage of flaking	
Scratches, Scuffing	Scuffing on roller end face and guide rib face (Fig. 4)	Excessive axial load, improper lubrication	 <p>Fig.2 Symmetrical flaking on each side. (Tapered Roller Bearing)</p>
	Scratches on raceway surface	Grease of too high viscosity, excessive acceleration in starting	
	Scratches on raceway surface on thrust bearing	Sliding of rolling element caused by centrifugal force during rotation	
Cracks, Chips	Cracks or chips of rolling element (Fig. 5)	Improper bearing material, excessive impact too wide internal clearance of cylindrical roller bearing	 <p>Fig.3 Flaking in the form of an oblique line. (Deep Groove Ball Bearing)</p>
	Cracks or chips of inner ring or outer ring (Fig. 5)	Advanced stage of flaking, improper bearing material, interference too large, housing of inaccurate design	
	Cracks, chips of rib (Fig. 5)	Impact in mounting, axial impact, load too heavy	
	Cracks, chips of cage	Improper lubricant or lubrication method, high speed operation, vibration impact too strong, advanced stage of wear	
Creep	Creep on inner/outer rings	Insufficient interference	 <p>Fig.4 Scuffing on roller end face and guide rib face. (Cylindrical Roller Bearing)</p>
Wear	Wear on inner/outer rings	Sliding abrasion, bearing of insufficient hardness, contamination by foreign matter(s), shortage of lubricant, improper lubrication	
	Wear caused by creep	Creep	
	Wear on cage	Contamination by foreign matter(s), improper lubrication, inclined bearing	
Rust, Corrosion	Rust on inner ring bore surface or outer ring O.D. surface	Fretting, water, humidity	 <p>Fig.5 Cracks and/or chips on inner ring or roller. (Spherical Roller Bearing)</p>
	Rust covering whole bearing surface, corrosion	Defective washing oil or lubricant, water, humidity	
Others	False brinelling (Fig. 6)	Progressing stage of flaws caused by load from vibration when machine is not running.	 <p>Fig.6 False brinelling on inner ring. (Deep Groove Ball Bearing)</p>
	Fluting on raceway surface or roller rolling surface (Fig. 7)	Passage of electricity	
	Discoloration	Heat generation, chemical action	
			 <p>Fluting Pitting</p> <p>Fig.7 Type of Electric pitting.</p>

Figure 34 - Ball bearing failure scenarios [62].

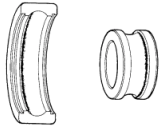
The main symptoms of the failure modes connected to wear and rolling fatigue are:

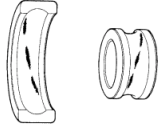
1. Increased abrasion will lead to an increased vibration frequency.
2. When the bearing elements loose mass the natural frequency of the system will be affected.
3. The acoustic emissions of the system might be affected, depending on the severity of the failure symptom.

4.2.5 Pugh matrix

Using the stakeholder needs, system information and fault scenarios we evaluate the most useful condition monitoring techniques identified in chapter 2.4.5. These techniques are then evaluated with regards to our chosen case study and failure scenarios in a Pugh matrix. The following assumptions and evaluations were made based on the interviews performed at Kverneland Group [57].

- Acoustic monitoring is not possible due to the close proximity of other machines in the production hall and is thus not covered in this thesis.
- The monitoring solution will have to be cost effective for it to be viable.

The values in the Pugh matrix diagram below range from 0 (worst) to 10 (best) and all evaluations are based on interviews with Kverneland personnel and authors knowledge.

Pugh Matrix				
	Vibration Monitoring	Oil Monitoring	Ultrasound Monitoring	Infrared Monitoring
Feasibility	8	2	3	5
Reliability	7	5	8	4
Maintainability	7	4	5	7
Accuracy	6	6	7	5
Cost level	8	2	3	5
Total	36	19	26	26

Infrared monitoring can be used to monitor the condition of a rotating machine based on the lack of uniformity as the temperature inconsistencies are an indication of equipment degradation [63]. The problems with using this technique is the reliability and accuracy as the heat emitting from ovens and other equipment may influence the sensors.

Ultrasound monitoring is used to monitor the subtle changes in frequencies and amplitudes as is regarded as the most reliable monitoring method for bearings. The change in amplitude measured by the ultrasound monitoring can indicate faults before vibration and heat changes

[64]. Requiring larger and more expensive sensors makes this technique less feasible than the others.

Oil monitoring is based upon measuring the amount of wear debris in the lubrication. This technique is not well suited as it gives no indication on what type of fault there is and requires an extensive refurbishing of the lubrication delivery system.

Vibration monitoring techniques are a solution well suited for this kind of rotating mechanical equipment. Allowing the user to identify and predict the fault scenarios on critical equipment based on their operating conditions. This analysis can be performed in real time to assess the condition of the equipment based on acceptance limits. Considering the chosen system and the fault scenario identified vibration monitoring is assessed as the most suitable condition monitoring solution.

4.3 Development of a framework for predictive maintenance

Based on the architecture proposed in chapter 2.1.5 a six-layered model is presented as a framework to develop a predictive maintenance programme for the selected system. The model below illustrates how the different layers are connected and how they are interconnected with the cost-effectiveness.

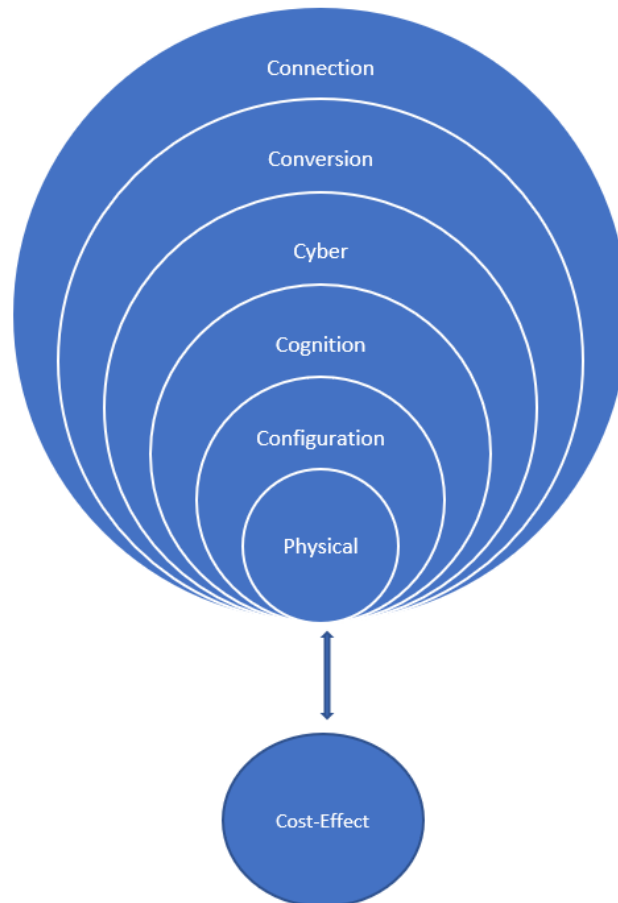

Figure 35 – Six-layered predictive maintenance model.

4.3.1 Physical

By performing the system analysis, an outline of the system context with focus on the critical components in the A300 mechanical forge press is established. along with their functions and operating conditions. Based on the failure analysis performed, a rolling bearing wear defect was identified as the most critical failure scenario within the selected case study. Further based on interviews and a Pugh matrix evaluation the vibration condition monitoring technique has been identified as the most suitable for establishing a predictive maintenance programme around. The faults identified are related to the bearings attached to the twin rotating wheels.

4.3.2 Configuration

The control system parameters are identified through the IDEF0 diagram along with the input and outputs of each process. Based on this analysis we are able to identify which parameters that are most useful for further monitoring on the A300. Through establishing a physical layer, we are able to identify the symptoms the relevant failure scenarios exercise on the system. This physical layer enables us to establish a monitoring system which can enable maintenance support in relation to these fault scenarios. The data produced by the monitoring system lays the foundations for building a database which a digitalized predictive maintenance programme can be built. In order to obtain an efficient and relevant databank having suitable and well-placed sensors is crucial. The parameters mentioned in chapter 2.4.3 identifies the parameters which can be analysed in vibration monitoring. These three parameters represent the motion of the machine and the selection of sensor depend on which of these that contain the frequency of interest [65].

- Velocity sensors are used for frequencies between 1 - 1000 Hz
- Displacement sensors are used for frequencies between 1 – 100 Hz
- Acceleration sensors are used for frequencies between 10 – 40 Hz

To be able to select the correct sensor needed to monitor the selected system some aspects should be considered [66]:

- Level of vibration present at the system
- Frequency range
- Sensitivity range
- Temperature
- Number of axis to be monitored
- Mounting challenges

The best choice after evaluating all the parameters and factors required for this system, the piezoelectric accelerometer is considered the best choice. This accelerometer delivers good sensitivity, broad frequency response and it is easy to mount and install on the A300 wheel-

bearing. There are several different types of piezoelectric sensors with a variety of temperature limits, which may suit the case study application [66].

Sensor placement is crucial to be able to receive reliable and accurate data from the bearing. The best regarded mounting method to achieve this is the use of threaded screws when mounting the sensor on the machine. The mounting location and method are directly affecting the performance of the solution [67]. Existing standards for vibration monitoring and studies are conflicted on whether a single triaxial sensor or three perpendicular directional sensors is the better choice as each has its own advantages. For the purpose of our system the three perpendicular sensors are the best choice as this enables an easy gathering of data and simple processing. This solution will also help limit the computational load caused by the data processing [68]. An illustration of how a sensor placement would look on our chosen case study is shown in the figure below. This shows the perpendicular mounted sensors around the bearing

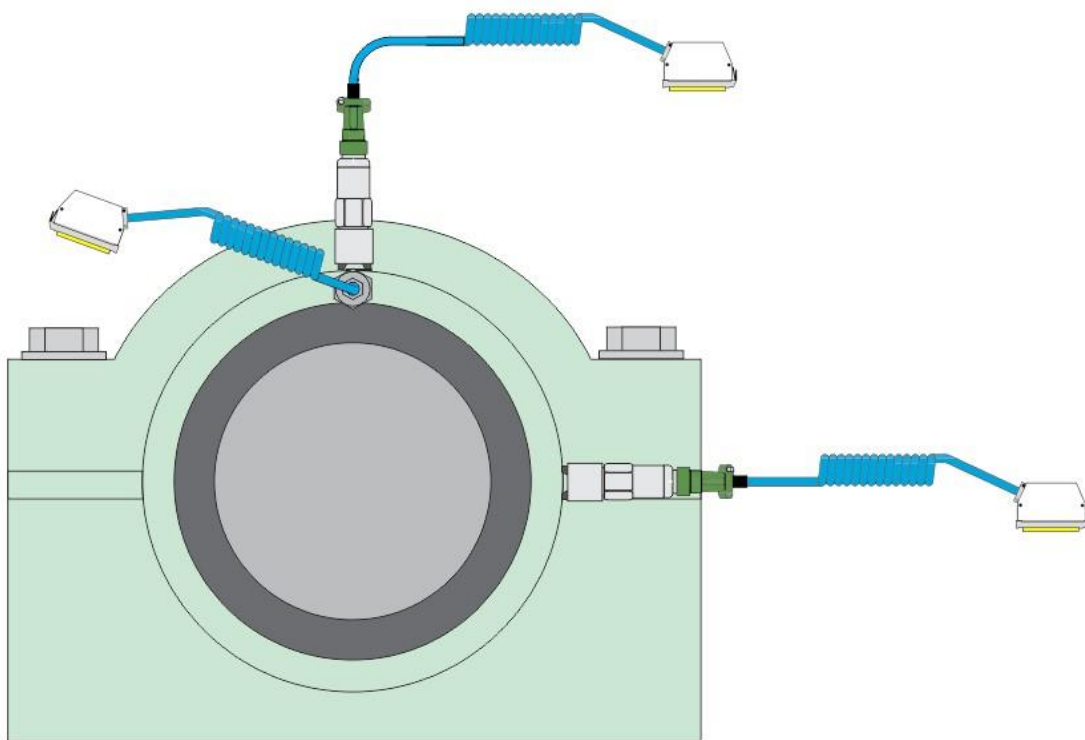

Figure 36 - Illustrative solution of sensor placement on bearing element [68].

The proposed illustrative solution is based on the sole monitoring of the wheel bearing, an important aspect to consider is that the predictive health monitoring could include more parts. Meaning, that if several sensors are to be implemented a wireless connection solution should be considered instead of a wired solution. In the case of our chosen system it is located in a

tricky spot in regard to wireless connectivity due to signal disturbances, and such a wired connection is recommended [57].

4.3.3 Cognition

Connecting the sensors is an important aspect of deciding what type of monitoring system one wants to build. Sensors can be connected to different kinds of hardware with its own advantages and disadvantages. Evaluating the criticality of the selected case study and its most critical fault scenario, being the wheel bearing, a continuous live online monitoring system should be considered.

In the proposed conceptual software and instrumentation solution provided by IOT Solutions the vibration data will be transmitted through a 16-bit analogue signal to a digital data acquisition system (A/D). Where the data then will be sent to their online cloud service Wonderware which is used to store the data and to make it viewable on a local computer. The illustration below shows how the physical architecture of the proposed solution would look like [69].

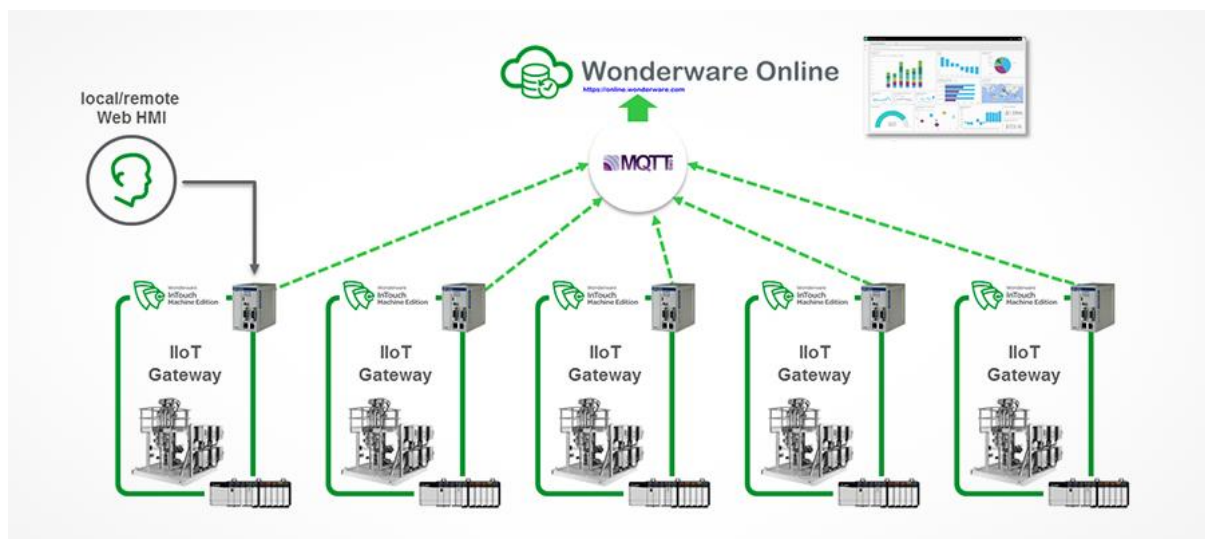

Figure 37 - Wonderware architecture [69].

4.3.4 Cyber

Having gathered the cognition data from the vibration sensors in an online cloud bank it requires processing to be usable as in a machine health analysis. Real time vibration data contain often contains noise pollutants from other machines in the production process. These

signal components need to be filtered out and there are several different techniques that can be used in such a process e.g. Cepstral Editing Procedure (CEP), Self-Adaptive Noise Cancellation (SANC), Time-Synchronous Averaging (TSA) and Discrete/Random Separation (DRS). CEP is recognized as a technique that outperforms the other with in terms of rolling bearing defects [70].

The process called CEP is a technique that uses an inverse Fourier transformation of the log spectrum to be able to reduce the amount of harmonic signal components present. The process in its entirety can be described in the figure below.

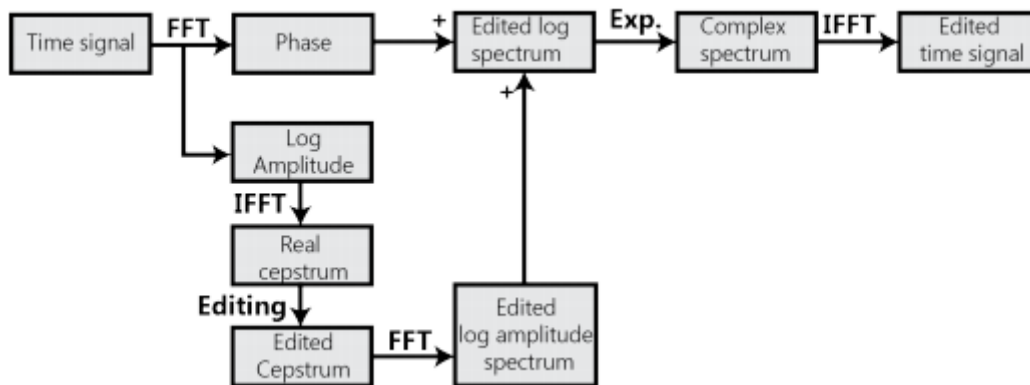

Figure 38 - Cepstral Editing Procedure process map [70].

In addition to filtering out the noise elements from the signal it also needs to be pre-processed to be able to achieve a usable output for the machine health analysis. This pre-processing transforms the signal input with a A/D converter into storable data.

4.3.5 Conversion

Having obtained and pre-processed the monitoring data they are ready for processing in order to analyse the frequency spectrum plots generated that is required for the vibration analysis. The time and frequency plots acquired in the cyber layer is then used to diagnose the bearing vibration data and identify faults. Since the fault characteristics and parameters are known we can establish a model for diagnosis and prognosis of machine faults in the wheel bearing. The general procedure model for how a conversion would take place is shown in the figure below.

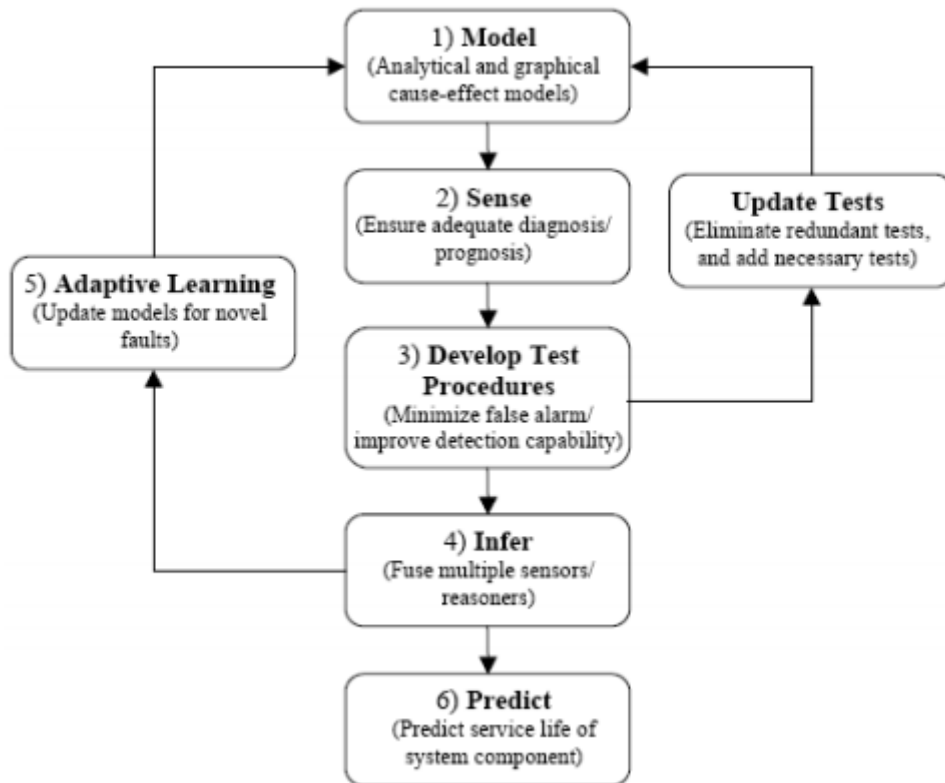

Figure 39 - Model for diagnosis and prognosis of machine faults [71].

The diagnosis of machine faults identifies the damages that have already occurred while the prognosis is all about predicting the damage that has not yet happened. The prognosis primarily focuses on modelling of the RUL of the assets involved.

4.3.6 Connection

The data and results generated in the process should enable action. In the connection layer information is visualised to the user, showing results of the analysis in reasonable manner. These results should enable the maintenance personnel to make choices based on the decision support at hand. The results from the vibration monitoring should be compared to established boundaries and limits that are decided upon, and in this way provide the user with a machine health estimate.

In Kverneland Groups pilot project the Wonderware software is used for visualisation of analysis and data from the monitoring sensors. The author also suggests the use of a tablet available for the operators with information regarding the data and maintenance information

regarding the asset. These data could be shown through an application tied to the Wonderware software so that the operators can get a sense of the machine health.

4.4 Implementation strategy for predictive maintenance framework

Having established through our case study how a framework for a predictive health monitoring program could be used to implement it on a machine level, a more general organizational approach can be developed. Based on our six-layered model this chapter will show the key aspects toward implementing a predictive maintenance strategy on a more organizational and factory wide level. The figure below shows us six-steps toward implementing a predictive maintenance strategy based on the discoveries made in the case study.

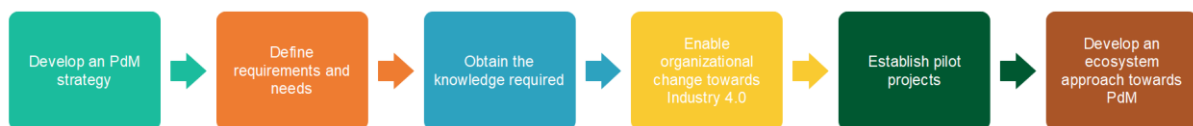

Figure 40 – Key steps for a successful implementation of a predictive maintenance strategy [34].

A simple process schematic for a strategic approach to predictive maintenance on the basis of the development and implementation strategies can be illustrated as a set of stages. These stages will prove as a general guideline of how a process of develop and implement a predictive maintenance program would look like. The figure below shows the conceptual solution developed for a general approach.

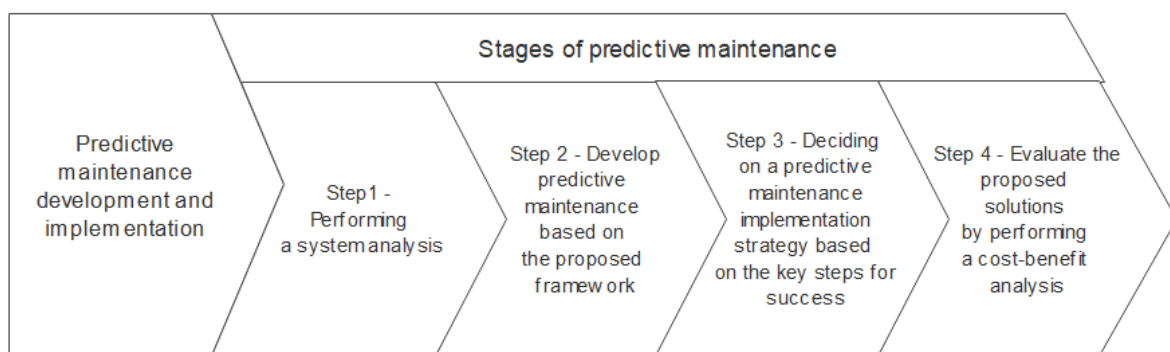

Figure 41 - Process of development and implementation of predictive maintenance based on the framework and strategy developed.

4.4.1 Developing a predictive maintenance strategy

Prior to establishing a predictive maintenance strategy on a more global perspective it is important to gain insights and knowledge of how its connected to Industry 4.0. Understanding how PdM plays a role in the Industry 4.0 ecosystem is crucial for developing it. The major part of digitalization and Industry 4.0 revolves around the transformation of physical information into digital. The decreased computing cost, cheaper cloud storage and less expensive hardware and sensors are making it more feasible to invest in the digitalization process [72].



Figure 42 - Physical to digital transformation [72].

By implementing this physical to digital transformation to the value chain in an organization, digital data can be gathered from different locations. One of the most important aspects to consider is the degree of maturity both in regard to the technology available but also the degree of development within the organization towards Industry 4.0.

It should be considered that there is a large variety of technologies and concepts with different levels of maturity and it is the combination of these that serve as the degree of maturity available. One way to evaluate technology maturity is through the Gartner hype cycle, which is a graphic illustration of the maturity and business application of technologies as shown in the figure below [73]. There are several steps included in interpreting a cycle:

- Technology trigger: The initial breakthrough of the technology leading to an event that causes significant interest.
- Peak of inflated expectations: The increased publicity and enthusiasm occur, some technologies may be successful, but typically there are more failures.
- Trough of disillusionment: Technologies often fail at meeting expectations in the beginning and become gradually unfashionable.
- Slope of enlightenment: Even though the press coverage and the technology are becoming unfashionable some companies continue through this phase and experiment with the technology.
- Plateau of productivity: The technology is more adopted by the mainstream media and user-pool. The technology is paying off with regards to applicability and relevance.

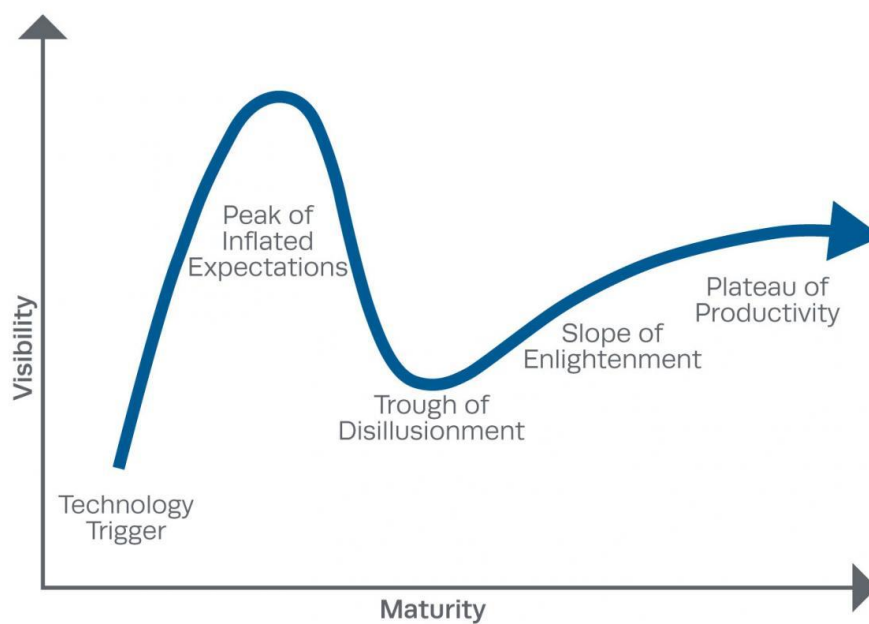

Figure 43 - Level of maturity in technologies [73].

Having established the level of maturity and technologies that are viable to adopt, the physical to digital transformation can be enabled on an asset level. Doing this will enable the organization to apply decision support with the information gathered. In this thesis this has been done by developing a predictive maintenance model for a specific fault in the asset.

As more assets are included in such a predictive maintenance program, Industry 4.0 enables more opportunities for the use of data driven methods. Some of these methods can be Big Data

processing algorithms and Machine Learning, focused on training the prediction models by pattern recognition and real time RUL estimations.

Having an overall strategy for what targets in terms of business value and maturity should be achieved needs to be consistent throughout the organization. Making sure that the predictive maintenance strategy aligns with the company's overall strategy is crucial as the company leadership should be ready and willing to implement the approach [34]. To achieve this, it is important to establish a roadmap for future development to reach the goals the organization has set. This can be done by establishing a chart that defines the strategic goals and defines the steps required to reach them. To be able to do this the company has to assess their current situation and evaluate their needs and requirements.

4.4.2 Defining requirements and needs

Having established a corporate structure for what is viable and sensible to implement knowing what the needs and requirements of the different part of the organization is essential. Most organizations have magnitude of assets not all relevant in the predictive maintenance system. Defining what assets could benefit most by implementing a predictive maintenance program is crucial [34].

Establishing goals tied to operational availability, data availability and other key performance indicators is used to prioritize which assets are most appropriate to begin with. Once established, the most critical assets identified should be broken down on a subsystem level to identify the possibilities and challenges tied to implementation.

The requirements and needs of each asset and stakeholder could vary, as well as the current established practice. Some assets may be straight forward with regards to condition monitoring and maintenance, other not so much. Investigating and obtaining knowledge about what the needs and requirements tied to the specific asset is crucial as the competences required for implementation can vary.

4.4.3 Obtain the knowledge required

The success of implementing a predictive maintenance programme is determined by the skills and competences the organization has at hand. Having established the needs and requirements

for implementation the biggest constraint might be the ability to obtain the personnel with the required competences. Developing strategies for how the organization can improve, learn or obtain the required skills and knowledge is key to achieving the targets identified. The knowledge, competence and needs depend strongly on the strategy and goals decided upon.

One of the most relevant competences relevant for our case study is vibration analysis knowledge. The degree of skill and competence will in many ways depend on the degree of integration, how much of the analysis will be performed “in house” or outsourced to other service providers. If the goal of the process is to implement and streamline the maintenance process, then outsourcing the analysis might be an effective solution. But if the goal of the company is to integrate the condition monitoring as part of a company-wide digitalization process then obtaining and keeping competencies within the company might be the better choice. ISO 18436 gives us an overview of four vibration analysis training levels that are needed ranging from a basic level to master [74].

Digitalization need to be prioritized and planned for in all levels of the organization. In order for digital transformations to be successful the organization is dependent on bridging the gap in existing digital skills and competences. Being perceptive of what types of leadership roles are required to drive the company’s digital transformation [75]. An illustration of some of the roles that are relevant in a digitalization and predictive maintenance management implementation is shown below.

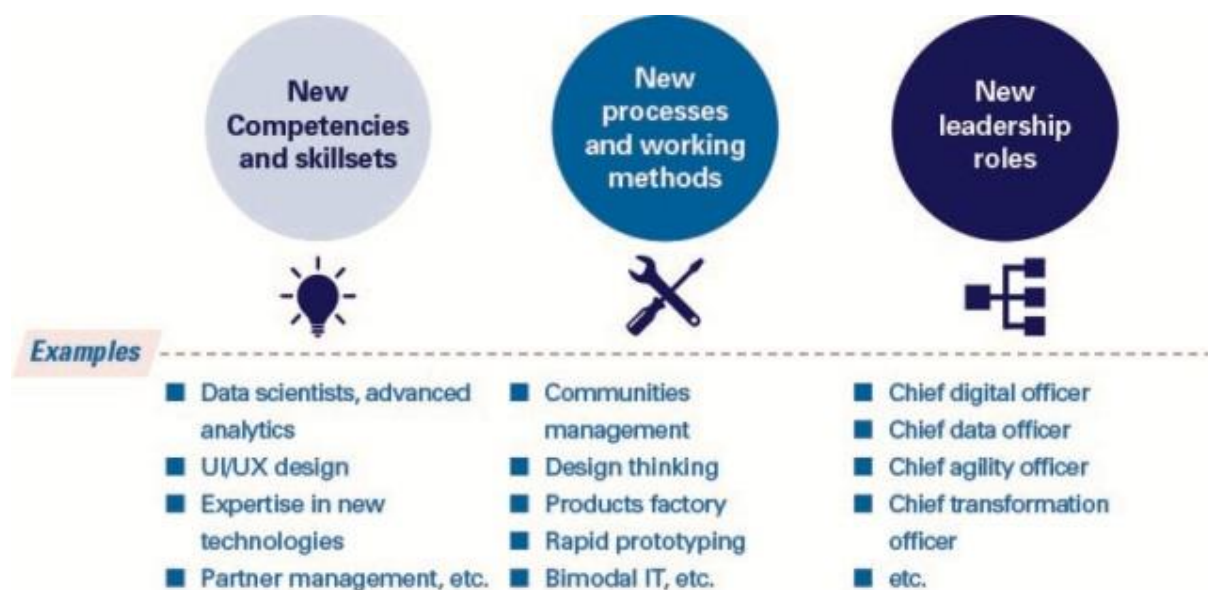

Figure 44 - Organizational roles in a digitalization process [75].

4.4.4 Enable organizational change towards Industry 4.0

In order for an organization to successfully undergo a digital transformation towards Industry 4.0 and predictive maintenance it needs to evaluate its corporate structure and culture. To be able to match the growing agility and flexibility of the customer base, analogue companies needs to break down its old mentalities and functions. Enabling the creation of an organization that thrives with cross functional collaboration and flow across departments. The collaboration will have to go beyond the scope of the organizational ecosystem to the partners and suppliers involved [75]. Some of the key aspects to consider when enabling such an organizational change is illustrated in the figure below.

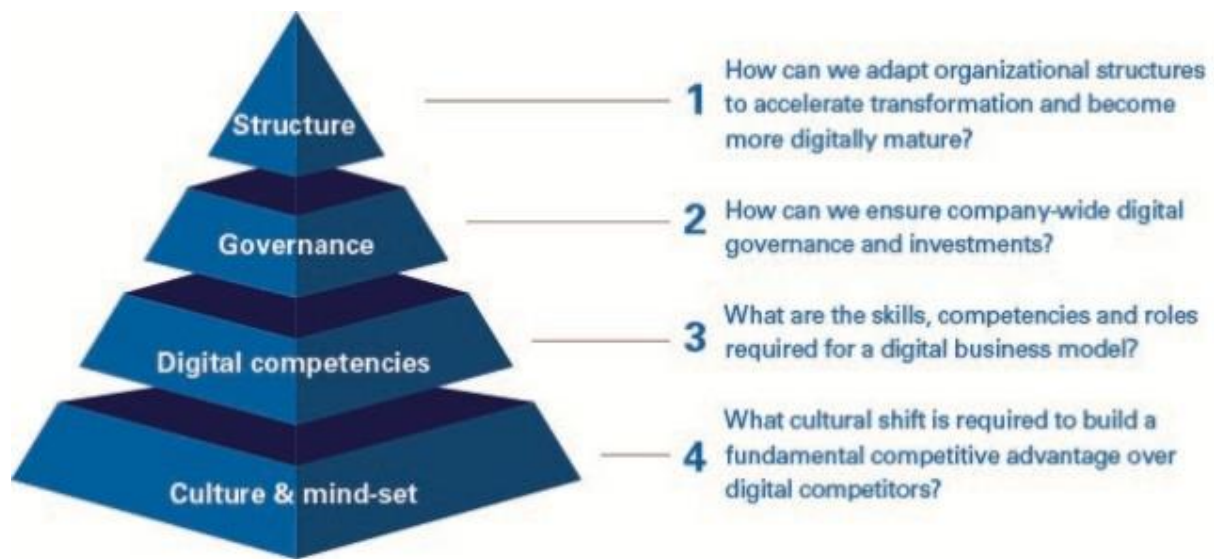

Figure 45 - Key areas of organizational change [75].

One of the biggest challenges in digitalization processes performed by analogue companies, is the need for overhaul of the company culture. Analogue companies that have succeeded has done so by creating strict systems and structures to be able to control complicated tasks and operations. In general, leading to a culture that in many ways hinder digital transformation, not enabling it. While in most cases the technology is at present and available to be implemented. The way of thinking and working within the organization needs to be evaluated and changed for the culture to improve.

4.4.5 Establish pilot projects

Having established the requirements of the system, obtained the knowledge needed and evaluated the organizational needs for change, a strategy for implementation should be established. Selecting assets that are suitable for a pilot project as a proof of concept and to

demonstrate the business value of it. This could be performed by producing a matrix containing information on how the different organizational goals align with data availability, business alignment and operational readiness. An example of how such a matrix might look is illustrated below.

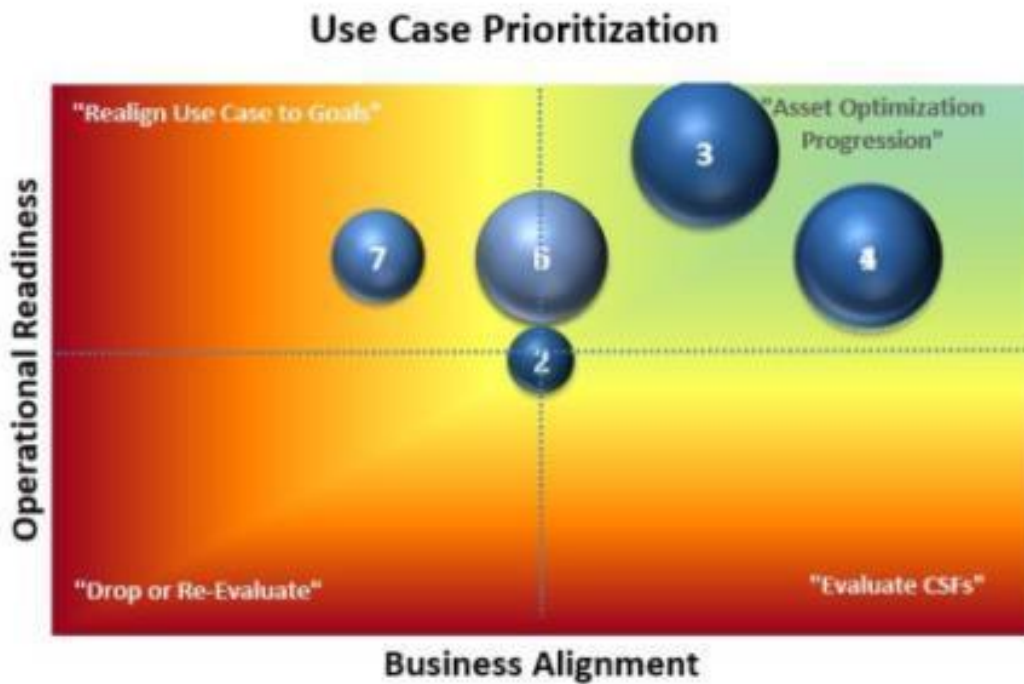

Figure 46 - Business goal matrix alignment [76].

Having established what knowledge and competences that are needed, this phase makes it is possible to identify the organizational shortcomings that might be undetected. Having this knowledge will make the scalability of the pilot project easier. An illustration on how an implementation strategy transforms from an asset level to a factory level is shown below.

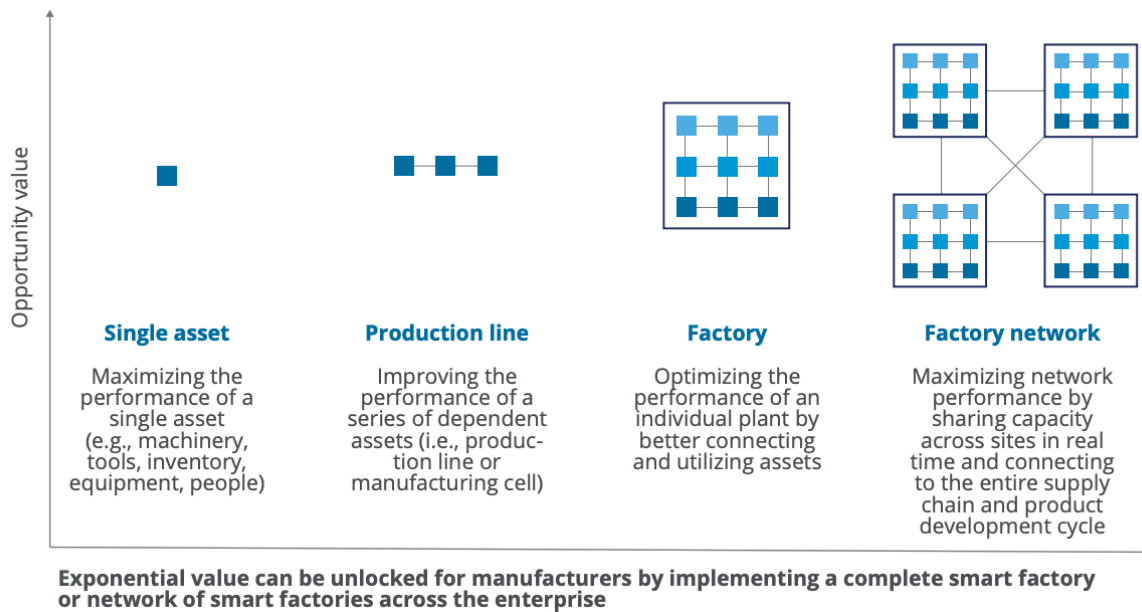

Figure 47 - Pilot project scalability [77].

By focusing on obtaining success on a pilot scale the solution is easily scaled to multiple assets with minimal risk associated. This process enables potential exponential value creation as the process does not need to be repeated for every asset and is connected together as an ecosystem with unique benefits [77].

4.4.6 Develop an ecosystem approach towards PdM

Having established and developed a predictive maintenance strategy and implemented it in the most relevant assets the maturity of the organization increases. The digital transformation and the development and knowledge obtained should enable collaboration. This is done so that suppliers, research centres and other external resources are better suited to participating in the value creation process. Having such a collaboration enables one to keep up to date with relevant new technologies and continue to maintain the technological maturity, ready to make new improvements when the opportunity arises. Having a good collaboration with different partners and resources enables the organization to develop interfaces and share models to create even more value with predictive maintenance.

4.5 Cost-benefit analysis

The cost of implementing a predictive maintenance management programme is tied directly to the cost of establishing sensors and instrumentation. This cost is often sent customized to companies by the providers and is such in general difficult to estimate. Having already established a pilot project, this allows us to take advantage of the offer made by IOT Solutions to Kverneland Group as a reference for the purpose of this cost-effect analysis. The sole purpose of any hardware or software mentioned in this chapter is to act as a reference for producing a cost estimate of the proposed model. This analysis will not consider the cost of maintainability of the solution, the price uncertainty in the future or changes in instrumentation cost. However, it will serve as an estimate based on authors own assumptions and knowledge.

4.5.1 Calculation of cost

For the cost-benefit we will evaluate a 10-year period when calculating the life-cycle cost of the system. The tables below contain the cost and expenses tied to monitoring installation and maintaining a cloud data solution. The data used in this analysis is based upon interviews made with maintenance personnel at Kverneland Group, consultants from IoT Solutions and authors own assumptions.

Table 13 – Illustrative installation and setup cost offer based on authors assumptions and interviews [57].

Product	Description	Number	Price per unit	Total price
Installation	Installation of software and equipment	1	10000	10000
Sensors and equipment	Vibration sensors and connection points	1	30000	30000
Total		40000 NOK		

Table 14 - Life cycle cost for the next 10 years.

Product	Description	Number	Price per unit	Total price
Wonderware	Software activation and system setup	1	1500	1500
Wonderware license	Software client (Yearly fee)	10	15000	150000
Cloud	Cloud solution (Yearly fee)	10	15000	150000
Total		301500 NOK		

The benefit of such a programme can be measured in the difference between the cost of the solution compared to the cost of failure. Kverneland desires that all major maintenance should occur within two weeks during July. Based on the information gathered during interviews and observation at Kverneland Group the following assumptions are made.

- During the last 10 years there has been 4 number of incidents which gives us a Mean Time To Failure (MTTF) of 2.5 years.
- The failure of the bearing will have no impact on other parts and will not lead to an increased cost.
- The value of lost production time is an estimate based on interviews performed with maintenance personnel.
- Unplanned downtime will not be assigned a value. Nonetheless it is important to consider the financial impact it could have to avoid it.
- The bearings will be inspected for 15 hours a year as preventive maintenance.

Based on these assumptions and data obtained during interviews the following expenses have been identified with a bearing defect.

Table 15 – Expenses with repairing a bearing defect [59].

Product	Description	Number	Price per unit	Total price
Bearing	Bearing parts	1	100000	100000
Repair manhours	Manhours spent on repairs	1	100000	100000
Lost production	The cost of lost production time	1	130000	130000
Total		330000 NOK		

Based on the information obtained regarding the bearing failure scenario the Risk Cost related to this event can be calculated. There are two possible scenarios that are the following:

Risk scenario 1: The bearing has a breakdown during the 50 weeks of the year when the factory has no shut down for maintenance and is such unplanned. The probability assigned for the event to happen during these 50 weeks are assumed to be $50/52 = 0.96$. The Risk Cost for this scenario is:

$$- \text{RC1} = (0.96 * 330\ 000) \text{ NOK/Event} * 2.5 \text{ Event/10 years} = 792\ 000 \text{ NOK}$$

Risk scenario 2: The bearing has a breakdown during the 2 weeks a year when the factory has a planned shutdown for maintenance. This event will eliminate the lost production value as there is no planned production. The probability assigned to this event is $2/52 = 0.04$. The Risk Cost for this scenario is:

$$- \text{RC2} = (0.04 * 200\ 000) \text{ NOK/Event} * 2.5 \text{ Event/10 years} = 20\ 000 \text{ NOK}$$

When implementing a condition monitoring system, the man-hour benefit from having real time monitoring compared to yearly preventive inspections can be defined based on the information received and an assumed hourly wage of 500 NOK per hour. Considering a 10-year period the man-hours saved is calculated by

$$- \text{MH} = 15 \text{ Hours/Year} * 500 \text{ NOK/Hour} * 10 \text{ Years} = 75\ 000 \text{ NOK}$$

It should be noted that the two risk scenarios should be considered as a best-case and worst-case scenario. With the best-case scenario being number 2 overall yearly Risk Cost is RC1 + RC2.

4.5.2 Cost-effect summary

Assuming a 10-year period a simple cost-effect analysis can be performed, the cash flows included in the analysis are assumed to be a one-time payment at the time of purchase and is not discounted. The following definitions are used for the incomes and expenditures in the table:

Incomes:

- RC: The total cost saved due to mitigating the risk by prediction the failure of the bearing.
- MH: The man-hours saved from eliminating the need for inspections.

Expenditures:

- CAPEX: Capital expenditure required to buy, install and configure the sensors and system.
- OPEX: The operational cost for maintaining and running the system for the next 10 years.

Table 16 - Cost-effect analysis summary.

Cash flow	Cash incomes	Cash expenditures
CAPEX		(-) 40 000 NOK
OPEX		(-) 301 500 NOK
RC	(+) 812 000 NOK	
MH	(+) 75 000 NOK	
Results	(+) 545 500 NOK	

Based on the proposed solution and the mentioned assumptions we observe that the solution could be cost effective.

6. Discussion

The main scope of this thesis was focused on developing a framework on which a predictive maintenance strategy could be built. Containing key aspects and drivers from the Industry 4.0 concept, this framework can be used for further development of Kvernland Group's digitalization effort. The framework was developed by exploring technologies and existing models that could serve as key drivers towards a predictive maintenance strategy, making the production facilities competitive in the coming years. The technologies and techniques that have been focused on is: Smart sensors, Smart factory, Maintenance and System Analysis with the Industry 4.0 concept at its core.

By first establishing the theoretical framework for Industry 4.0, disruptive technologies and maintenance the adhering challenges and opportunities could be discovered. This theoretical knowledge was crucial in establishing a framework of which a predictive maintenance strategy could be developed. Therefore, based upon the objectives and scope decided upon in chapter 1, it is the authors opinion that the thesis scope of work has been achieved.

In this thesis the bigger picture of how Industry 4.0 and predictive maintenance are intertwined and how it can be used to create value on a machine level are identified. When viewed in a reliability-centred maintenance point of view, there is no maintenance programme that is better than the other. As the goal of the maintenance performed is to achieve the highest availability and reliability with the lowest possible life cycle cost. However, it is stated that the quality of the maintenance programme increases as one move from a reactive to a more proactive approach [36]. This view is in many ways supported by the way Industry 4.0 enables the connection and generation of data required to enable a high-performance predictive maintenance strategy.

The six-layered framework for implementing predictive maintenance used in the case study was developed based on the 5C cyber-physical system proposed by Jay Lee and the RAMI 4.0 architecture. The framework takes advantage of the purpose of the 5C and RAMI 4.0 models to develop a cyber-physical system for managing Big Data from several machines in a network. However, the framework developed mainly focuses on one source of data in the case study. As a result of this, the true potential of it it's not truly utilized. The framework has been used to model and give clarity on a machine level for the purpose of developing a predictive

maintenance programme. However, once the framework is established and an infrastructure is present, more machines can be connected. Thus, enabling the full potential of the framework and giving the possibility for a network of machines connected and communicating through the cyber space.

To decide on which asset is the most suitable for predictive maintenance, a detailed system and failure analysis is required to be able to identify where the highest risk and biggest gain is. In this thesis a FMECA was performed as a bottom-up approach, as it is detailed and covers all the components in the system. The FMECA requires broader interdisciplinary knowledge to be able to produce satisfying results. This analysis was performed with input from several stakeholders at Kverneland Group and such it provides a more detailed and valuable result than an FTA analysis.

Once a system has been established and the proposed architecture is in place the investment cost of scaling the solution to cover Kverneland Group's other critical equipment will be lower. With the architecture in place, the majority of cost will be related to the purchase and installation of sensors and equipment. The scaling of the predictive maintenance solution will make implementation easier for the remaining assets and could potentially lead to an exponential value creation.

6.1 What is learned

The thesis provided a detailed and complex understanding of how the maintenance and Industry 4.0 concept correlate in the manufacturing industry. It also provides a good understanding and insight of how the technical, organizational and operational challenges impact each other and how the maturity of the organization impacts it all. The scope of this thesis enabled the author to obtain an understanding in topics as Industry 4.0, maintenance, IoT and system thinking. In the process of discussing and obtaining the information and knowledge required to perform this thesis the author has discovered how immense such an Industry 4.0 digitalization endeavour is. Starting a process of transforming the entire value chain is a great and long-term undertaking that requires just the right types of people with the right types of competences. The people and technologies involved in this undertaking would need to work well together with the required planning and commitment from all parties to be successful. However, this thesis has opened the eyes of the author in terms of the immense potential that lies in the benefit of

implementing a predictive maintenance strategy based on Industry 4.0 and digitalization drivers, such that it could surpass the gain by previous industrial revolutions.

6.2 Main challenges

What provided the biggest challenge was the need to comprehensively investigate and explore fields like Industry 4.0, maintenance, condition monitoring and cyber-physical systems to be able to evaluate the operational and informational needs of the case study. Substantial amount of time was used in determining what technologies and areas that would be suitable for Kverneland Groups application and more importantly which were not suitable. Furthermore, the process of adapting the RAMI 4.0 and 5C architecture into one framework for implementing a predictive maintenance strategy proved to be challenging. Also, keeping an eye throughout the thesis for any pitfalls while focusing on a red thread throughout the thesis proved challenging.

One other aspect to consider when to perform an analysis of a case study is what is the best methodology to approach the system with. The decision on which type of analysis and choice of system the author based the decisions on discussions with supervisors and previous literature. The challenge by doing this, was the aspect of reliability on the information given. Hence, a proper quality assurance on the information given was needed. Having concluded on a specific path to follow in this thesis, assuming a specific solution and predicting how the future may look like, proved a difficult task and one which there might be disagreements on.

6.3 Further recommendations

The main recommendation based on this thesis is that Kverneland Groups should consider following the developed framework for predictive maintenance implementation. The knowledge gained by evaluating the case study provided in this thesis can be used as a guideline for the initiation of a pilot project. More research should be done on the vibration analysis when data become available as there was not any at the time of this thesis. The company should also do a thorough assessment to ensure that the competencies within the organization in relation to Industry 4.0, predictive maintenance and vibration monitoring is at the desired level.

Once a pilot project is performed and the results and performance are verified the system analysis model can be used to identify more critical components in critical assets. By

identifying these critical applications, a predictive maintenance strategy can be developed based on the six-layered framework. As more assets are integrated and interconnected into such a solution, more usable data will be produced. This data will enable Industry 4.0 features like Big Data, Machine Learning and Artificial Intelligence to provide a data driven approach to predictive maintenance. This could position Kverneland Group to be able to take the next steps in a digitalization effort.

Future research could and should focus on other areas within analytics, predictive maintenance and emerging technologies. As the potential for Industry 4.0 and digitalization is far from utilized at this point. Areas like Machine Learning, Big Data processing and Artificial Intelligence should be focused on, as we are just only beginning to scratch the surface of their true potential in predictive maintenance. The technologies developed could then in turn be used in other parts of the value chain leading to a fully digitalized ecosystem. Future research should focus on increasing the level of knowledge in every level of the digitalization process and Industry 4.0 concept.

7. Conclusion

A framework for predictive maintenance for a land-based company from an Industry 4.0 perspective can be developed and implemented in a cost-efficient manner by using the six layered framework and the key steps toward successful implementation. The proposed framework model developed for predictive maintenance presents a six-layered process from the physical asset layer to the connection layer where the results are shown.

Based on the framework a simple four step process model is developed for the development and implementation of predictive maintenance. The first stage consists of the system analysis and breaking down the system through a flowchart to identify the most critical asset. In the second stage the six-layered framework is used to develop a predictive maintenance strategy for that asset. In the third stage the proposed strategy is further developed on an organizational level in order to serve as a roadmap for implementation. Lastly, the cost-benefit analysis is performed to complete the evaluation of the system and the proposed solution. The proposed framework, when used on the A300, can serve as a short-term pilot project in order to investigate the viability of the project.

The six-layered framework and the six key steps toward successful implementation has been developed and evaluated through an Industrial case scenario where a rotating mechanical forge press as the case study. Based on the system analysis performed and FMECA the rotating bearings connected to the wheel elements were identified as the most critical failure scenario. This wear fault scenario can be monitored using vibration sensors which evaluates the natural frequency of the machine. The failure scenario comes with a large cost when it is not detected and requires regular inspections.

The developed solution based on the six-layered framework is a good tool to enhance the production and to be able to cut down on fixed and variable maintenance hours. As the operators and maintenance personnel lacks the competence in analytics and digitalization it is recommended to evaluate the needs and qualities needed to gain the potential benefits of implementation.

The cost benefit of the proposed framework for predictive maintenance has been compared to the benefits gained by mitigating the risk involved with the identified failure scenarios. The

analysis showed that over a 10-year period, the proposed solution would save the company over 500 000 NOK. This number is by far accurate as some assumptions were made not only by the author, but also by the interview object at Kverneland Group. Nonetheless, it serves as a rough estimate to establish further research on.

Based on the literature review, the current development in the industry towards the Industry 4.0 concept and the information obtained through the case study, a six-step model has been developed for a successful implementation of predictive maintenance programme. This model combined with the framework and information gathered enables the organization to understand the role predictive maintenance has in the Industry 4.0 digitalization process. This process shows the necessity for a framework and strategy to be able to evaluate the current status of the organization and the value gained by it. A good first step towards executing a predictive maintenance strategy is to start small by a pilot project and establishing the type of competences that are required to make it successful. Thus, increasing the maturity of the organization for further steps toward digitalization.

References

- [1] i-scoop, «Digital transformation in the manufacturing industry: challenges and accelerators,» [Internet]. Available: <https://www.i-scoop.eu/digital-transformation/digital-transformation-manufacturing/>. [Funnet 17 March 2019].
- [2] A. C. Uzialko, «Industry 4.0: How Technology is Revolutionizing the Manufacturing Industry,» *Business News Daily*, 15 November 2017. [Internet]. Available: <https://www.businessnewsdaily.com/10156-industry-manufacturing-iot.html>. [Funnet 8 February 2019].
- [3] Deloitte, «The future of manufacturing,» [Internet]. Available: <https://www2.deloitte.com/tr/en/pages/manufacturing/articles/future-of-manufacturing-industry.html>. [Funnet 25 March 2019].
- [4] Deloitte, «Industry 4.0 and manufacturing ecosystems,» [Internet]. Available: <https://www2.deloitte.com/tr/en/pages/manufacturing/articles/industry-4-0-manufacturing-ecosystems-exploring-world-connected-enterprises.html>. [Funnet 24 March 2019].
- [5] C. Schröder, «Obstacles for the technological implementation of Industry 4.0,» i *The Challenges of Industry 4.0*, Research Gate, 2016, pp. 11-12.
- [6] U. G. D. Kumar, «Maintenance in the Era of Industry 4.0: Issues and Challenges,» i *Quality, IT and Business Operations*, Singapore, Springer, 2017, pp. 231-250.
- [7] S. Smith, «Qualtrics,» 28 May 2018. [Internet]. Available: <https://www.qualtrics.com/blog/research-problem/>.
- [8] Kverneland Gruppen, «Kverneland Gruppen: Om oss,» Kverneland Gruppen, [Internet]. Available: <https://no.kvernelandgroup.com/Om-oss/Kort-om-Kverneland-Group/Om-oss>. [Funnet 14 February 2019].
- [9] K.-D. W. S. W. T. Thoben, «"Industrie 4.0" and Smart Manufacturing – A Review of Research Issues and Application Examples,» *Research Gate*, January 2017.
- [10] History, «Industrial Revolution,» [Internet]. Available: <https://www.history.com/topics/industrial-revolution/industrial-revolution>. [Funnet 27 March 2019].
- [11] E. Niller, «History,» [Internet]. Available: <https://www.history.com/news/second-industrial-revolution-advances>. [Funnet 27 March 2019].
- [12] Sentryo, «The 4 industrial revolutions,» 23 February 2017. [Internet]. Available: <https://www.sentryo.net/the-4-industrial-revolutions/>. [Funnet 27 March 2019].
- [13] K. Schwab, «The Fourth Industrial Revolution: what it means, how to respond,» *World Economic Forum*, 14 January 2016. [Internet]. Available: <https://www.weforum.org/agenda/2016/01/the-fourth-industrial-revolution-what-it-means-and-how-to-respond/>. [Funnet 27 February 2019].
- [14] M. Rouse, «Techtarget,» 1 December 2016. [Internet]. Available: <https://whatis.techtarget.com/definition/disruptive-technology>. [Funnet 27 March 2019].
- [15] J. C. M. B. J. Manyika, «McKinsey Digital - Disruptive technologies: Advances that will transform life, business, and the global economy,» May 2013. [Internet]. Available: <https://www.mckinsey.com/business-functions/digital-mckinsey/our-insights/disruptive-technologies>. [Funnet 5 April 2019].
- [16] R. S. P. Ravnå, «Industry 4.0 and Maintenance,» *Norsk Forening for Vedlikehold*, Lysaker, 2016.
- [17] J. K. H.-A. B. B. Lee, «A Cyber-Physical Systems architecture for Industry 4.0-based manufacturing,» December 2014. [Internet]. Available: https://www.researchgate.net/publication/269709304_A_Cyber-Physical_Systems_architecture_for_Industry_40-based_manufacturing_systems. [Funnet 12 March 2019].
- [18] E. Hozdić, «Smart factory for industry 4.0: A review,» *ResearchGate*, p. 35, January 2015.
- [19] SICK, «Sensor Intelligence - DRIVING YOUR INDUSTRY 4WARD – sensor intelligence as the foundation of Industry 4.0,» [Internet]. Available: <https://www.sick.com/ch/en/sensor-intelligence-as-the-foundation-of-industry-40/w/industry40/>. [Funnet 4 April 2019].
- [20] K. F. Steinsland, «A model to develop and implement a predictive maintenance programme complying with Industry 4.0 vision: A case study in Skretting AS,» *University of Stavanger*, Stavanger, 2018.

- [21] M. N. F. Milojevic, «Digital Industrial Revolution with Predictive Maintenance,» CXP Group, London, 2018.
- [22] M. Bunzel, «Internet of Things - As much as half of every dollar you spend on preventive maintenance is wasted,» IBM, 4 May 2016. [Internet]. Available: <https://www.ibm.com/blogs/internet-of-things/as-much-as-half-of-every-dollar-you-spend-on-preventive-maintenance-is-wasted/>. [Funnet 29 May 2019].
- [23] K. Schweichart, «Reference Architectural Model Industrie 4.0 (RAMI 4.0),» Federal Ministry for Economic Affairs and Energy, [Internet]. Available: https://ec.europa.eu/futurium/en/system/files/ged/a2-schweichart-reference_architectural_model_industrie_4.0_rami_4.0.pdf. [Funnet 1 May 2019].
- [24] A. C. C. V. O. Y. Ahmadi, «A review of CPS 5 components architecture for manufacturing based on standards,» i *11th International Conference on Software, Knowledge, Information Management and Applications (SKIMA)*, Malabe, Sri Lanka, 2017.
- [25] Syque, «Syque - Quality tools,» [Internet]. Available: http://www.syque.com/quality_tools/tools/Tools19.htm. [Funnet 10 April 2019].
- [26] S. Burge, «The Systems Engineering Tool Box,» 2009. [Internet]. Available: <https://www.burgehugheswalsh.co.uk/uploaded/1/documents/pugh-matrix-v1.1.pdf>. [Funnet 14 March 2019].
- [27] What is Six Sigma, «Pugh Matrix,» [Internet]. Available: <https://www.whatissixsigma.net/pugh-matrix/>. [Funnet 16 February 2019].
- [28] Remi AI, «Medium,» 21 February 2019. [Internet]. Available: <https://medium.com/@RemiStudios/remaining-useful-life-in-predictive-maintenance-ffc91d7e4a97>. [Funnet 4 May 2019].
- [29] Techopedia, «Computerized Maintenance Management System (CMMS),» Techopedia, [Internet]. Available: <https://www.techopedia.com/definition/25281/computerized-maintenance-management-system-cmms>. [Funnet 27 February 2019].
- [30] R. Senduk, «Principles of CMMS Implementation,» i *International Maintainability, Availability, Process Safety, Reliability Exhibition & Conference*, 2018.
- [31] J. P. Jospeh, «Maintenance Philosophy,» i *45th Turbomachinery & 32th Pump Symposia*, Houston, Texas, 2016.
- [32] L. Martins, «Infraspeak - Advantages and Disadvantages of Corrective Maintenance,» [Internet]. Available: <http://home.infraspeak.com/advantages-and-disadvantages-corrective-maintenance/>. [Funnet 10 March 2019].
- [33] Micromain, «Micromain - What is Preventive Maintenance,» [Internet]. Available: <https://www.micromain.com/what-is-preventive-maintenance/>. [Funnet 13 March 2019].
- [34] M. M. M. Haarman, «Predictive Maintenance 4.0 - Predict the unpredictable,» PwC, 2017.
- [35] S. Kennedy, «RxM: What is prescriptive maintenance, and how soon will you need it?,» Plant Services, 23 May 2017. [Internet]. Available: <https://www.plantservices.com/articles/2017/rxm-what-is-prescriptive-maintenance-and-how-soon-will-you-need-it/?show=all>. [Funnet 20 March 2019].
- [36] Accelix, «Proactive maintenance - What is Proactive Maintenance,» 26 March 2018. [Internet]. Available: <https://www.accelix.com/community/proactive-maintenance/what-is-proactive-maintenance/>. [Funnet 2 March 2019].
- [37] G. V. W. B. A. D. A. Vogl, «NISTIR 8012 Standards Related to Prognostics and Health Management (PHM) for Manufacturing,» National Institute of Standards and Technology, 2014.
- [38] T. Brown, «Failure Analysis Tools: Choosing the Right One for the Job,» Reliable Plant, [Internet]. Available: <https://www.reliableplant.com/Read/31171/failure-analysis-tools>. [Funnet 27 February 2019].
- [39] J. Glancey, «Failure Analysis,» Research.Me, 2006. [Internet]. Available: <http://research.me.udel.edu/~jglancey/FailureAnalysis.pdf>. [Funnet 27 February 2019].
- [40] M. Villacourt, «Failure Mode and Effects Analysis (FMEA): A Guide for Continuous Improvement for the Semiconductor Equipment Industry,» International Sematech, Austin, TX, 1992.
- [41] Weibull, «Weibull - Basics,» [Internet]. Available: <https://www.weibull.com/basics/fmea.htm>. [Funnet 18 April 2019].
- [42] SKF, «Condition Monitoring,» SKF, [Internet]. Available: <https://www.skf.com/group/products/condition-monitoring/index.html>. [Funnet 4 March 2019].

- [43] FLUKE, «FLUKE - Condition Monitoring,» [Internet]. Available: <https://www.fluke.com/en-us/products/condition-monitoring/vibration>. [Funnet 17 March 2019].
- [44] Thornton, «Slideplayer - Presentation on Vibration Analysis,» 2016. [Internet]. Available: <https://slideplayer.com/slide/5784318/>. [Funnet 17 March 2019].
- [45] A. W. F. M. Lees, «Where Next for Condition Monitoring of Rotating Machinery?,» Michael Friswell, [Internet]. Available: http://michael.friswell.com/PDF_Files/J124.pdf. [Funnet 2 May 2019].
- [46] Free vibration analysis, «Vibration Analysis,» [Internet]. Available: <http://freevibrationanalysis.blogspot.com/2011/08/brief-introduction-to-vibration.html>. [Funnet 12 March 2019].
- [47] Hyper Physics, «Simple Harmonic Motion Calculation,» [Internet]. Available: <http://hyperphysics.phy-astr.gsu.edu/hbase/shm.html>. [Funnet 29 March 2019].
- [48] Azima DLI, «Complex Vibration,» [Internet]. Available: <http://azimadli.com/vibman/complexvibration.htm>. [Funnet 27 March 2019].
- [49] L. Johnson, «Sciencing - How to calculate Natural Frequency,» 29 April 2018. [Internet]. Available: <https://sciencing.com/calculate-natural-frequency-5171316.html>. [Funnet 2 March 2019].
- [50] Metra Mess- und Frequenztechnik, «Gracey: Piezoelectric Accelerometers - They and Application,» 2001. [Internet]. Available: <http://www.gracey.co.uk/downloads/accelerometers.pdf>.
- [51] C. Sanders, «A Guide to Vibration Analysis and Associated Techniques In Condition Monitoring,» DAK Consulting, London.
- [52] J. Mais, «SKF - Spectrum Analysis,» May 2002. [Internet]. Available: <https://www.skf.com/binary/tcm:12-113997/CM5118%20EN%20Spectrum%20Analysis.pdf>. [Funnet 7 March 2019].
- [53] Cleveland State University, «Detection of Cracks in Rotating Machinery,» [Internet]. Available: <https://academic.csuohio.edu/romadyc/research/projects/shaft-crack-detection.html>. [Funnet 8 March 2019].
- [54] H. Wang, «A Feature Extraction Method Based on Information Theory for Fault Diagnosis of Reciprocating Machinery,» April 2009. [Internet]. Available: https://www.researchgate.net/publication/224933942_A_Feature_Extraction_Method_Based_on_Information_Theory_for_Fault_Diagnosis_of_Reciprocating_Machinery. [Funnet 8 March 2019].
- [55] Kverneland Group, «Kverneland Group - Om oss,» [Internet]. Available: <https://no.kvernelandgroup.com/Om-oss/Kort-om-Kverneland-Group/Historie>. [Funnet 15 February 2019].
- [56] Kverneland Group, *Internal Documents*, Klepp: Kverneland Group, 2019.
- [57] K. D. Aanderaa, Interviewee, *Interview and tour of Kverneland factory at Klepp*. [Intervju]. 7 February 2019.
- [58] Aveva, «Wonderware,» Aveva, [Internet]. Available: <https://sw.aveva.com/wonderware>. [Funnet 25 May 2019].
- [59] S. Henriksson, Interviewee, *Interview and analysis*. [Intervju]. 25 April 2019.
- [60] H. S. S. C. A. U. I. Saruhan, «Vibration Analysis of Rolling Element Bearings Defects,» *Journal of Applies Research and Technology*, pp. 284-295, June 2014.
- [61] R. K. K. L. A. S. Upadhyay, «Rolling element bearing failure analysis: A case study,» i *Case Studies in Enginnering Failure Analysis*, Elsevier, 2013, pp. 15-17.
- [62] Koyo, «Ball & Roller Bearings: Failures, Causes and Countermeasures,» JTEKT Corporation, Japan, 2009.
- [63] A. Desselle, «Processing Magazine: Thermal monitoring with infrared sensors,» 11 December 2017. [Internet]. Available: <https://www.processingmagazine.com/thermal-monitoring-with-infrared-sensors/>. [Funnet 5 May 2019].
- [64] A. Messer, «CBM Connect: Ultrasonic Predictive Maintenance: Monitoring Bearing Wear,» 225 November 2018. [Internet]. Available: <https://www.cbmconnect.com/ultrasonic-predictive-maintenance-monitoring-bearing-wear/>. [Funnet 5 May 2019].
- [65] L. Fedele, «From Basic Maintenance to Advanced Maintenance,» i *Methodologies and Technigues for Advanced Maintenance*, Springer, 2011, pp. 63-112.

- [66] Wilcoxon - Sensing Technologies, «Wilcoxon - Sensing Technologies,» November 2018. [Internett]. Available: https://wilcoxon.com/wp-content/uploads/2018/11/TN16_Sensor-selection-guide_2018.pdf. [Funnet 12 May 2019].
- [67] Azima DLI, «Plantservices,» Azima DLI , 2009. [Internett]. Available: https://www.plantservices.com/assets/knowledge_centers/azima/assets/appnote_tri-ax-vs-singleaxis.pdf. [Funnet 25 May 2019].
- [68] Hansford Sensors, «Triaxial Vs Single Axis Accelerometers,» Hansford Sensors - Excellence in Vibration Monitoring, [Internett]. Available: <https://www.hansfordsensors.com/triaxial-vs-single-axis-accelerometers/>. [Funnet 25 May 2019].
- [69] Wonderware, «HMI - SCADA,» [Internett]. Available: <https://www.wonderware-benelux.com/en/hmi-scada/intouch-machine-edition/#>. [Funnet 25 May 2019].
- [70] C. G. P. H. J. Peeters, «Vibration data pre-processing techniques for rolling element bearing fault detection,» i *July*, Athens, Greece, 2016.
- [71] X. Jiang, «Recent Development in Structural Damage Diagnosis and Prognosis,» General Electric, June 2010. [Internett]. Available: https://www.researchgate.net/publication/233596289_Recent_Development_in_Structural_Damage_Diagnosis_and_Prognosis. [Funnet 24 May 2019].
- [72] S. Laaper, «Supplying the Supply Chain,» InformationWeek, 1 September 2017. [Internett]. Available: <https://www.informationweek.com/strategic-cio/supplying-the-supply-chain/a/d-id/1327853>. [Funnet 26 May 2019].
- [73] MITRE, «Systems Engineering Guide - Assessing Technical Maturity,» [Internett]. Available: <https://www.mitre.org/publications/systems-engineering-guide/acquisition-systems-engineering/acquisition-program-planning/assessing-technical-maturity>. [Funnet 27 May 2019].
- [74] IRIS Maintenance Technologies Co. Ltd, «ISO 18436 Category II-Cut Sheet-Topics-published (1),» Slideshare, 14 January 2016. [Internett]. Available: <https://www.slideshare.net/IRISMaintenanceTechn/iso-18436-category-iicut-sheettopicspublished-1>. [Funnet 10 April 2019].
- [75] J. D. J. K. T. L. A. D. Andren, «Make sense of digitalisation by exploring four key areas,» Asset Finance International, 13 June 2018. [Internett]. Available: <https://www.assetfinanceinternational.com/index.php/digitalisation/wcg-blog/17080-making-sense-of-digital-by-exploring-four-key-areas>. [Funnet 29 May 2019].
- [76] L. Watts, «The Key to Implementing a Successful Predictive Maintenance Strategy,» Preseidon, [Internett]. Available: <https://www.presidion.com/blog-the-key-to-implementing-a-successful-predictive-maintenance-strategy/>. [Funnet 28 May 2019].
- [77] R. M. A. L. S. H. M. S. B. Burke, «Deloitte,» Deloitte - University Press, 2017. [Internett]. Available: https://www2.deloitte.com/content/dam/insights/us/articles/4051_The-smart-factory/DUP_The-smart-factory.pdf. [Funnet 29 May 2019].
- [78] Z. Stamboliska, E. Rusinski og P. Mozco, «2. Maintenance Management and Applied Strategies,» i *Proactive Conditon Monitoring of Low-Speed Machines*, Springer International Publishing, 2015, p. 193.
- [79] Oxford Dictionary, «Maintenance,» [Internett]. Available: <https://en.oxforddictionaries.com/definition/maintenance>. [Funnet 4 March 2019].
- [80] S-cool , «Simple Harmonic Motion,» [Internett]. Available: <https://www.s-cool.co.uk/a-level/physics/simple-harmonic-motion-and-damping/revise-it/simple-harmonic-motion>. [Funnet 21 March 2019].
- [81] B. Marr, «Forbes,» 2 September 2018. [Internett]. Available: <https://www.forbes.com/sites/bernardmarr/2018/09/02/what-is-industry-4-0-heres-a-super-easy-explanation-for-anyone/#58e7c3c49788>. [Funnet 27 March 2019].
- [82] M. P. T. O. B. Hernabb, «Design Principles for Industry 4.0 Scenarios: A Literature Review,» Working Paper, 2015.
- [83] M. H. M. Mulders, «Predictive Maintenance 4.0 - Predict the unpredictable,» Mainnovation, June 2017. [Internett]. Available: <https://www.mainnovation.com/wp-content/uploads/tmp/58e418c645624c08e147d5f9c476d1370f2cc191.pdf>. [Funnet 25 March 2019].

