



University of  
Stavanger

Faculty of Science and Technology

## MASTER'S THESIS

Study program/Specialization:  Mechanical and Structural Engineering and Material Science / Civil Engineering	Spring semester, 2021  Open
Writer: Glenn Severin Rimestad	<i>Glenn Severin Rimestad</i>
Faculty supervisor: Samindi Samarakoon  External supervisor(s): Erik Tveiten, Sweco	
Thesis title:  Design of Røydalen Bridge considering both linear and non-linear material and geometric behaviour	
Credits (ECTS): 30	
Key words:  Structural Analysis Pre-stressed concrete bridge Linear Analysis Non-linear Analysis Geometric non-linearity Material non-linearity	Pages: 73  + enclosure: 59  Stavanger, 15.06.2021 Date/year

## Preface

---

This thesis marks the end of my two-year master's degree in constructions and materials at the University of Stavanger. The thesis was written in the spring of 2021 and represents 30 study points.

The objectives throughout the thesis has been to dig deeper into the theory of concrete structures, as well as gaining practical knowledge of bridge modelling and design. During this process, my interest in structural engineering has increased and I am looking forward to practise what I have learned in my educational pathway.

The thesis is written in collaboration with the bridge department at Sweco Stavanger. I would like to thank the department for their thrust, and especially my supervisor Erik Tveiten who have been an invaluable asset and conversation partner throughout the process. Without the guidance and professional discussions, especially concerning Sofistik, this thesis would not have been feasible.

I would also like to thank my supervisor from University of Stavanger, Associate Professor Samindi Samarakoon, for her insightful guidance and attention during this period.

Finally, a special thanks to my family and friend who have supported me all these years through education. This period would not have been the same without the academic discussion with colleague students, social diversion with friends and the support from my family.

Glenn Severin Rimestad

*Glenn Severin Rimestad*

Stavanger, 15.06.2021

## Abstract

---

Traditional design of reinforced concrete structures is based on the assumption of linear elastic behaviour of concrete and steel, even though the materials behaviour rarely is linear in reality. This thesis compares the required reinforcement of Røydalen Bridge when designed for linear versus non-linear material and geometrical behaviour.

The prestressed concrete bridge was completed in 2019 as a part of the highway E18 at the south coast of Norway. Modelling, analysing and design was performed in the FEM software Sofistik by the engineers that today are employed at Sweco of which the thesis is written in collaboration with.

Firstly, knowledge about the main subjects was gained as preparations for the analyses. A literature review was conducted to better understand non-linear analyses and material behaviour. Methods of analyses and design guidelines was catalogued to properly perform and understand the later work. Simultaneously, the learning of Sofistik was initiated through learning exercises and modelling.

Sofistik is an advanced FEM software which are particularly directed at structural and civil engineering. The software is composed in a modular structure that enables solutions of complex and advanced problems through several methods, including pre-defined, graphical and coding user interfaces. As the software is accommodated for traditional analysis, constructing and performing the linear analysis proved unproblematic. Sofistik automatically returns the design load combinations if coded correctly. Global non-linear analyses are normally not conducted, which was obvious as the information was sometimes insufficient and unclear. During configuration, a limitation of pre-stressed concrete beam-elements in the software was discovered. As a result, the objective was altered from the whole bridge to only the columns.

The software does not automatically return the non-linear design load combinations, as the principle of superposition is not valid. This meant that 1539 individual load combination was to be performed per analysis. After constructing the whole analysing code through Visual Studio, each analysis consisted of 32 337 written lines. As the structure is checked for SLS, ULS a and ULS b, 97 011 written lines was required to perform the non-linear analyses. In the end, each non-linear analysis consumed approximately 48 hours to perform.

Non-linear behaviour proved to require less reinforcement than linear. In critical sections, the difference was substantial, ranging from 21 to 49% and at most 33  $\emptyset$ 20 bars. Total accumulated required reinforcement was minimal, however.

The combination of material and geometrical non-linearity formed a ductile structure with constantly changing stiffness matrix (or E-modulus). As the structure deforms, inferior internal forces are required to withstand the applied loads, compared to the linear analysis that are not allowed to deform. The ductile behaviour, hence, the lesser internal forces, explains the difference in required reinforcement. However, as the concrete is a brittle material, the linear analysis is more compatible with its characteristics. The reinforcement provides capacity in tension, but with the non-linear combination, yielding occurs at a lower stress and strain stage.

With the simplicity and degree of accuracy in linear analysis, the complex non-linear global analyses cannot be justified if linear analyses are applicable. The linear analyses require more reinforcement but provides a more secure and compatible behaviour to the concrete's brittle characteristics.

# Table of content

---

Preface.....	I
Abstract .....	II
List of Figures .....	VI
List of Tables.....	IX
1. Introduction .....	1
1.1 Objectives .....	2
1.2 Limitations .....	2
2. Theory .....	3
2.1 Linear analysis.....	3
2.2 Non-linear analysis .....	4
2.2.1 Geometric non-linearity .....	5
2.2.2 Material non-linearity .....	7
2.2.3 Application of non-linearity.....	7
2.3 Materials.....	9
2.3.1 Concrete .....	9
2.3.2 Reinforcing steel.....	13
2.3.3 Prestressing steel .....	13
3. Analysis and design guidelines.....	15
3.1 Analysis and design approach .....	15
3.1.1 Partial factor of safety / limit state .....	15
3.1.2 Simulation based approach.....	16
3.2 Design guidelines .....	17
3.3 Loads and load combinations .....	18
3.3.1 Permanent loads .....	18
3.3.2 Variable Loads .....	18
3.3.3 Temperature Loads .....	19
3.3.4 Traffic loads .....	21
3.3.5 Deformation loads.....	24
3.3.6 Load Combinations.....	24
3.3.7 Non-linear analysis combinations .....	25
4. Modelling in Sofistik.....	26
4.1 Sofistik .....	26
4.2 Flow chart of analysing process.....	28
4.3 Theoretical principles .....	30
4.3.1 ASE.....	30

4.3.2	Non-linear analysis in ASE .....	31
4.3.3	DESI – Reinforced Concrete Design.....	33
5.	Case Study: Røydalen Bridge .....	34
5.1	Description.....	34
5.2	Materials.....	36
5.2.1	Concrete .....	36
5.2.2	Reinforcing Steel .....	36
5.2.3	Prestressing steel .....	36
5.3	Loads and load combinations .....	37
5.3.1	Permanent loads .....	37
5.3.2	Temperature Loads .....	38
5.3.3	Traffic loads .....	40
5.3.4	Linear load combinations .....	41
5.3.5	Non-linear load combinations.....	41
5.4	Analytical model .....	43
5.4.1	Cross-sections and geometric constants.....	44
5.4.2	Verification of analytical model .....	45
6.	Results of the Analysis .....	47
6.1	Linear Analysis .....	48
6.1.1	Service limit state .....	48
6.1.2	Ultimate limit state 6.10a.....	50
6.1.3	Ultimate limit state 6.10b .....	53
6.2	Non-linear analysis .....	56
6.2.1	Service limit state .....	56
6.2.2	Ultimate limit state 6.10a.....	59
6.2.3	Ultimate limit state 6.10b .....	61
6.3	Comparison.....	64
6.3.1	Resulting forces .....	64
6.3.2	Design .....	65
6.3.3	Material properties .....	65
7.	Discussion .....	68
7.1	Linear analyses .....	68
7.2	Non-linear analyses .....	68
7.3	Comparison.....	69
7.4	Modelling.....	70
7.5	Sources of error .....	71

8. Conclusion.....	72
8.1 Further work.....	73
References.....	74
Appendices.....	76

## List of Figures

Figure 2-1: Illustration of a linear system. [6] .....	3
Figure 2-2: Linear steps in structural systems [6] .....	4
Figure 2-3: Non-linear steps in structural systems [6] .....	4
Figure 2-4: Fishing rod as a practical example of geometric non-linearity. [9].....	5
Figure 2-5: Linear and non-linear strain [6].....	6
Figure 2-6: Consequence of equilibrium in deformed shape [5] .....	6
Figure 2-7: Non-linear material models. (a) Linear and nonlinear elastic spring models. (b) Elasto-plastic spring models. (c) visco-elastic spring models. [6].....	7
Figure 2-8: Illustration of the different iteration procedures at a) Newton-Raphson and b) Modified Newton-Raphson [7] .....	8
Figure 2-9: Typical stress-strain curves for concrete under uniaxial compression. [1].....	9
Figure 2-10: Idealized stress-strain curve for concrete in compression. [3] .....	10
Figure 2-11: Concrete strain versus time for a specimen subjected to constant sustained stress. [1] .....	11
Figure 2-12: Idealised stress-strain relationship for concrete in uniaxial compression [12] .....	12
Figure 2-13: a) Actual and b) idealised stress-strain curves for reinforcing steel. [1].....	13
Figure 2-14: Typical stress-strain curve for tendons. [1].....	14
Figure 3-1: Illustration of partial factor design philosophy. [13].....	15
Figure 3-2: Illustration of LM1 applied to a lane. Gathered from [21] but changed from 5,5 to 5,4 which is correct according to NA. ....	21
Figure 3-3: Details for LM1 from NS-EN 1991-2 [18].....	22
Figure 3-4: Illustration of LM2. [21] .....	22
Figure 3-5: Assessment of groups of traffic loads. [18].....	24
Figure 4-1: Flowchart of Sofistik structure. [24].....	26
Figure 4-2: Workflow of linear analysis                      Figure 4-3: Workflow of non-linear analysis .....	28
Figure 4-4: Possible feedback-types after running a task .....	29
Figure 4-5: Standard stress-strain curves used in ASE. sig-m: Serviceability, sig-u: Ultimate design, sig-r: Calculatoric mean. [25] .....	31
Figure 4-6: Overview of elements applicable for non-linear analyses. [25].....	32
Figure 4-7: Column geometric nonlinear theory, 2nd and 3rd order. [25] .....	32
Figure 4-8: Girder using second- and third-order theories. TH3 induces a load carrying normal force N. [25] .....	32
Figure 5-1: Side-view illustration of Røydalen bridge .....	34
Figure 5-2: Cross-section of bridge deck, dimensions in millimetres. Larger scale figure is found in Appendix A .....	35
Figure 5-3: Section of Piers and foundations, dimensions in millimetres. Larger scale figure is found in Appendix A .....	35
Figure 5-4: Concrete properties from Sofistik.....	36
Figure 5-5: Reinforcing steel properties from Sofistik .....	36
Figure 5-6: Pre-stressing steel properties from Sofistik.....	36
Figure 5-7: Snapshot from Sofiplus-X illustrating applied permanent loads. ....	37
Figure 5-8: Approach slab.....	38
Figure 5-9: Modelling of temperature loads .....	39
Figure 5-10: Vertical section illustrating the traffic loads .....	40
Figure 5-11: Horizontal section illustrating the traffic loads.....	40
Figure 5-12: Implementation of creep and shrinkage using PLC from CSM.....	42
Figure 5-13: Set up of a single non-linear load combination .....	42
Figure 5-14: Analytical model, screenshot from SSD .....	43

Figure 5-15: Cross-section of bridge deck from Sofistik, dimensions given in millimetres.....	44
Figure 5-16: Static properties of bridge deck cross-section.....	44
Figure 5-17: Cross-section of column from Sofistik, dimensions given in millimetres .....	44
Figure 5-18: Static properties of column cross-section.....	44
Figure 5-19: Bending moment diagram [kNm] for self-weight g1 .....	46
Figure 6-1: SLS load combination returning highest My .....	48
Figure 6-2: Required longitudinal reinforcement [cm <sup>2</sup> /m], linear SLS.....	48
Figure 6-3: Resulting max bending moment My [kNm], linear SLS.....	48
Figure 6-4: Resulting minimum bending moment My [kNm], linear SLS .....	49
Figure 6-5: Design capacity max My [kNm], linear SLS .....	49
Figure 6-6: Design capacity min My [kNm], linear SLS .....	49
Figure 6-7: Max axial force N[kN], linear SLS .....	49
Figure 6-8: Design axial capacity N [kN], linear SLS.....	49
Figure 6-9: Maximum stress in reinforcement [MPa], linear SLS.....	50
Figure 6-10: Maximum strain in cross-section at top of column five, element nr. 50098.....	50
Figure 6-11: Maximum compressive stress in concrete [MPa], linear SLS.....	50
Figure 6-12: ULS a load combination returning highest My.....	50
Figure 6-13: Required longitudinal reinforcement[cm <sup>2</sup> /m], linear ULS a .....	51
Figure 6-14: Maximum bending moment My [kNm], linear ULS a.....	51
Figure 6-15: Minimum bending moment My [kNm], linear ULS a .....	51
Figure 6-16: Design capacity max My [kNm], linear ULS a.....	51
Figure 6-17: Design capacity min My [kNm], linear ULS a.....	51
Figure 6-18: Max normal force N [kN], linear ULS a.....	52
Figure 6-19: Design capacity N [kN] from design case giving min my, linear ULS a.....	52
Figure 6-20: Design capacity N [kN] from design case giving max my, linear ULS a .....	52
Figure 6-21: Maximum compression stress in concrete [MPa], linear ULS a.....	52
Figure 6-22: Maximum stress in cross-section 50098, at top of column 5, linear ULS a .....	52
Figure 6-23: Maximum strain in cross-section 50098, at top of column 5, linear ULS a.....	53
Figure 6-24: ULS b load combination returning highest My .....	53
Figure 6-25: Required longitudinal reinforcement [cm <sup>2</sup> /m], linear ULS b .....	53
Figure 6-26: Maximum bending moment My [kNm], linear ULS b .....	53
Figure 6-27: Minimum bending moment My [kNm], linear ULS b.....	54
Figure 6-28: Design capacity max My [kNm], linear ULS b.....	54
Figure 6-29: Design capacity min My [kNm], linear ULS b .....	54
Figure 6-30: Max axial force N[kN], linear ULS b.....	54
Figure 6-31 Design capacity N [kN] from design case giving max my, linear ULS b .....	54
Figure 6-32: Design capacity N [kN] from design case giving min my, linear ULS b.....	55
Figure 6-33: Maximum stress in cross-section 50098, at top of column 5, linear ULS b .....	55
Figure 6-34: Maximum strain in cross-section 50098, at top of column 5, linear ULS b .....	55
Figure 6-35: Maximum compressive stress in concrete [MPa], linear ULS b .....	55
Figure 6-36: System visualization in SSD of LC 1554, non-linear ULS b.....	56
Figure 6-37: LC 1563 which return max my in non-linear SLS combination .....	56
Figure 6-38: Required longitudinal reinforcement [cm <sup>2</sup> /m], non-linear SLS .....	56
Figure 6-39: Maximum bending moment My [kNm], non-linear SLS LC 1563.....	57
Figure 6-40: Design capacity My [kNm], non-linear SLS LC 1563 .....	57
Figure 6-41: Axial force N [kN], non-linear SLS LC 1563.....	57
Figure 6-42: Design axial force N[kN], non-linear SLS LC 1563 .....	57
Figure 6-43: Stress distribution in reinforcement in top of column 5 [MPa], non-linear SLS LC 1626.....	57
Figure 6-44: Strain distribution in reinforcement in top of column 5 [%], non-linear SLS LC 1626.....	58



Figure 6-45: Maximum compressive stress in concrete [MPa], non-linear SLS LC 1536.....	58
Figure 6-46: Total curvature $k_y$ [1/m], non-linear SLS LC 1563.....	58
Figure 6-47: Plastic curvature $\gamma$ [1/m], non-linear SLS LC 1563 .....	58
Figure 6-48: LC 1536 which returns max $M_y$ in non-linear ULS a combination .....	59
Figure 6-49: Required longitudinal reinforcement [ $\text{cm}^2/\text{m}$ ], non-linear ULS a .....	59
Figure 6-50: Maximum bending moment $M_y$ [kNm], non-linear ULS a .....	59
Figure 6-51: Design capacity $M_y$ [kNm], non-linear ULS a .....	59
Figure 6-52: Axial force $N$ [kN], non-linear ULS a .....	60
Figure 6-53 Design capacity axial force $N$ [kN], non-linear ULS a .....	60
Figure 6-54: Stress distribution in reinforcement in top of column 5 [MPa], non-linear ULS a LC 1536 .....	60
Figure 6-55: Strain distribution in reinforcement in top of column 5 [%], non-linear ULS b LC 1536 .....	60
Figure 6-56: Maximum compressive stress in concrete [MPa], non-linear ULS a LC 1536 .....	60
Figure 6-57: Total curvature $k_y$ [1/m], non-linear ULS a LC 1536 .....	61
Figure 6-58: Plastic curvature $\gamma$ [1/m], non-linear ULS a LC 1536.....	61
Figure 6-59: LC 1554 which returns max $m_y$ in non-linear ULS b combination. ....	61
Figure 6-60: Required longitudinal reinforcement [ $\text{cm}^2/\text{m}$ ], nonlinear ULS b.....	61
Figure 6-61: Maximum bending moment diagram $M_y$ [kNm], non-linear ULS b LC 1554 .....	62
Figure 6-62: Design capacity $M_y$ [kNm], non-linear ULS b LC 1554 .....	62
Figure 6-63: Axial force $N$ [kN], non-linear ULS b LC 1554 .....	62
Figure 6-64: Design capacity axial force $N$ [kN], non-linear ULS b LC 1554.....	62
Figure 6-65: Stress distribution in reinforcement at top of column 5 [MPa], non-linear ULS b LC 1635.....	62
Figure 6-66: Strain distribution in reinforcement at top of column 5 [%], non-linear ULS b LC 1635 .....	63
Figure 6-67: Maximum compressive stress in concrete [MPa], non-linear ULS b LC 1635.....	63
Figure 6-68: Total curvature $k_y$ [1/m], non-linear ULS b LC 1554 .....	63
Figure 6-69: Plastic curvature $\gamma$ [1/m], non-linear ULS b LC 1554.....	63
Figure 6-70: Number of elements in columns.....	64
Figure 6-71: Relative E-modulus per column, SLS LC 1509 .....	66
Figure 6-72: Relative E-modulus of columns, ULS a LC 1572 .....	67
Figure 6-73: Relative E-modulus of columns, ULS b LC 1554 .....	67
Figure 7-1: Visualization of the system excited of temperature combination LC 95 .....	69
Figure 7-2: Visualization of the system excited of temperature combination LC 94 .....	70

# List of Tables

---

Table 2-1: Strength and deformation characteristics of concrete. [1].....	10
Table 3-1: Characteristic self-weights .....	18
Table 3-2: Load combinations of traffic loads .....	20
Table 3-3: Characteristic loads, LM3 .....	23
Table 5-1: Applied permanent loads .....	37
Table 5-2: Temperature load variables .....	38
Table 5-3: Temperature combinations.....	39
Table 5-4: Applied traffic loads .....	40
Table 5-5: Applied safety factors to load combinations, favourable/unfavourable .....	41
Table 5-6: Verification of geometric properties.....	45
Table 5-7: Comparison of hand calculations and Sofistik-values of bending moments.....	45
Table 6-1: Comparison of the resulting forces and capacities at top of column 5.....	64
Table 6-2: Comparison of resulting forces and capacities at bottom of column 5 .....	64
Table 6-3: Comparison of accumulated reinforcement .....	65
Table 6-4: Comparison of required reinforcement in top of column 5.....	65
Table 6-5: Comparison of material properties in element 50098.....	65
Table 6-6: Comparison of force in steel reinforcement in element 50098(x=0).....	65
Table 6-7: System properties in the non-linear analyses .....	66
Table 6-8: E-modulus at top, bottom and middle for column 5, SLS: LC 1509 ULSa: LC 1572 ULSb: LC 1554 .....	66

# 1. Introduction

---

When designing reinforced concrete structures, most often the analysis is based on the assumption of linear elastic behaviour of concrete and steel [1]. In reality, the concrete material behaviour is not linear, even under in-service conditions. The linear elastic assumption was derived for hand calculations and was established before the introduction of sophisticated finite element software's. It enables several calculation laws, in example the generalizes Hook's law and the principle of superposition, which makes calculating of the response of complex structures more feasible. However, when analysing typical stress-strain curves for concrete and steel, the materials has potentials beyond the linear behaviour. Hence, it is valid to assume that a structure designed considering non-linear behaviour could stand higher loads than one designed for linear behaviour, or the non-linear structure could be designed with less reinforcement than the linear.

This report is written in collaboration with Sweco and their bridge design department in Stavanger. The engineers at Sweco are specialized within modelling and design of bridges using the FEM software "Sofistik". In the initial collaboration meetings, a curiosity to check out the difference in linear and non-linear design was discussed. Naturally, a case study of an already completed bridge designed by the engineers at Sweco formed a satisfactory thesis for both parts. All necessary documents and reference models were gathered from Sweco, in addition to necessary supervision.

During the educational pathway at University in Stavanger, the basic knowledge of the thesis main subjects, FEM-design and design of concrete structures, were covered. The report seeks to gain practical knowledge of the FEM-design of concrete structures and in addition add new knowledge within bridge design and non-linear analysis.

The report first presents all relevant basis information to perform the analyses, including relevant theory and analysis and design guidelines. Then the FEM software Sofistik is presented with its modelling, analysing and design procedure. Background information to the case study is carried out before the chapters Results, Discussion and Conclusion. At last, subjects that could be interesting to investigate further is listed.

The case study methodology is chosen as it allows exploration and understanding of complex issues, applicable for in-depth investigations [2].

## 1.1 Objectives

The assumption of non-linear design demands less reinforcement is investigated in this thesis through a case study of Røydalen Bridge, Norway. With the potential in the stress-strain curves follows several parameters to analyse and compare. The linear and non-linear behaviour must be carried out to compare the results properly and in regard to expected results. The research question of this thesis is:

***What is the difference in amount of required reinforcement when designing a bridge based on a linear analysis versus a material and geometric non-linear analysis?***

There are several challenging parameters in the thesis, as the structure, the non-linear analysis and the software are complex by itself. To perform the analyses, an analytical model must be developed and placed in a realistic load environment. As global non-linear analysis is usually not performed, the procedure of non-linear analysis must be elaborated. The author must learn a new complex software in a short period of time. Summarized, the research question is answered if the list of objectives can be answered.

- Gather practical knowledge of FEM-design of pre-stressed concrete bridges
- Increase knowledge of non-linear analysis
- Complete and verify a linear analysis
- Complete a non-linear analysis
- Compare the required reinforcement with linear and non-linear behaviour

## 1.2 Limitations

While working on the thesis, several challenges occurred. Especially problems related to the non-linear analysis and the software was time-consuming and challenging. These were dealt with in different ways, some were only possible to solve with a simplification. Other limitations are in place to simplify the non-linear analysis, which proved to be substantial and time-consuming. The limitations used in this report are as follows:

- Non-linear analysis is only conducted for the columns as pre-stressed beam-elements are not applicable to non-linear analyses in Sofistik.
- Loads and load cases are limited to the minimum to simplify the non-linear analysis. This means that loads due to wind, seismic, eccentric traffic and accidents are not conducted.
- Only longitudinal reinforcement is considered.

## 2. Theory

### 2.1 Linear analysis

Structural analyses for static excitation are based on the relation between force and displacements for a structural system or members of the systems [3]. To obtain this relation, several methods can be used. Two regular methods are the method of mechanics of materials and the method of continuum mechanics [4]. Both are based on simplified assumptions that enables load-stress or load-deflection relations to be solved. Regular assumptions made are:

- Linear distributed stress and strain in cross-sections
- Plane sections remain plane after loading
- Linear elastic material behaviour
- Assessment of infinitesimal sections
- Assessment of only one stress-state or force at the time
- Equilibrium is found calculating at the undeformed system [5]

As structural engineering only allows small displacements, several of these assumptions are applicable and enables several common structural analysis principles and laws. If a structure is excited by several loads that do not affect the magnitude of each other (e.g. they are assessed one by one), and the material remain linear elastic after combining the loads together, the method of superposition becomes valid. For linear elastic materials, the generalized Hooke' law is valid as the stress-strain relationship is linear. When using this relationship, the system matrices remains constant with only the response matrix being dependent on the applied loads, as shown in Figure 2-1 [6]. This accelerates the calculations, with the only new input being applied forces, and output of displacements/reaction forces. Behind all assumptions and principles are the three basic requirements of equilibrium, compatibility and constitutive relations. The system must satisfy all three of these laws to be solved [4].

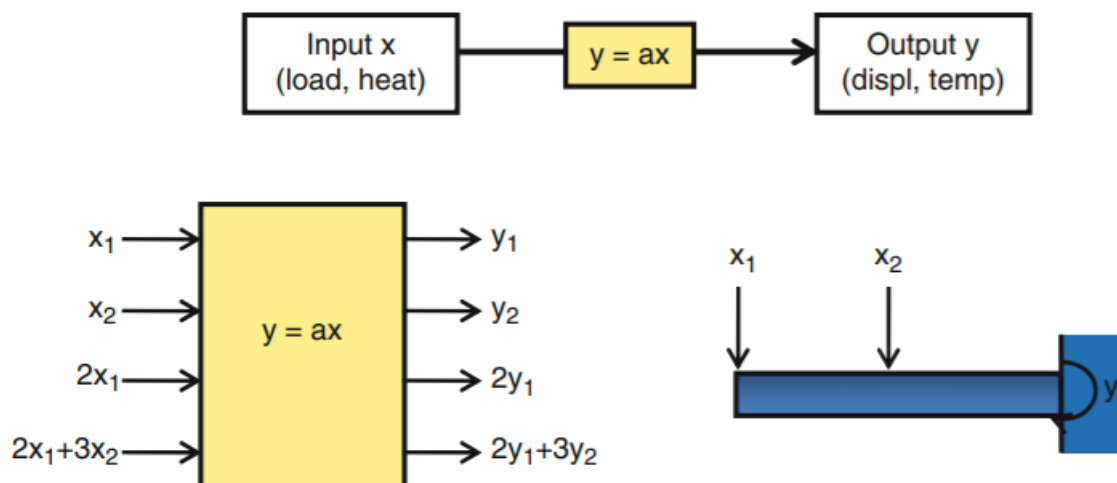

Figure 2-1: Illustration of a linear system. [6]

## 2.2 Non-linear analysis

Non-linear systems are defined as everything that is not linear [6]. In reality, all practical problems or static systems contain non-linear behaviour. As there exist methods for linear calculations which does not deviate too much from non-linear calculations, these are used to simplify models and calculations. In linear systems it is sufficient to calculate the system once, as each step behaves linearly and therefore the principle of superposition is valid. With non-linear behaviour the principle of superposition becomes invalid, forcing the engineer to construct a new system for each step in the calculations.

Figure 2-2 display how each step in the structural system is assumed linear, making it possible to predict the system behaviour and use known formulas in calculations. In Figure 2-3, the different non-linear categories in solid mechanics are displayed. In structural mechanics these are categorized as material, geometric and contact non-linearity [7]. The problems in these categories are non-linear because stiffness, and sometimes loads, becomes functions of displacement or deformation. Thus, it is not possible to immediately solve for displacement or deformation, as the stiffness and load boundary conditions are not known already. To obtain the displacement, and consequently the stiffness and loads applied, an iterative process is required until the system equations are in equilibrium.

In this thesis, geometric and material non-linearity are the relevant non-linear categories, hence they are elaborated further.

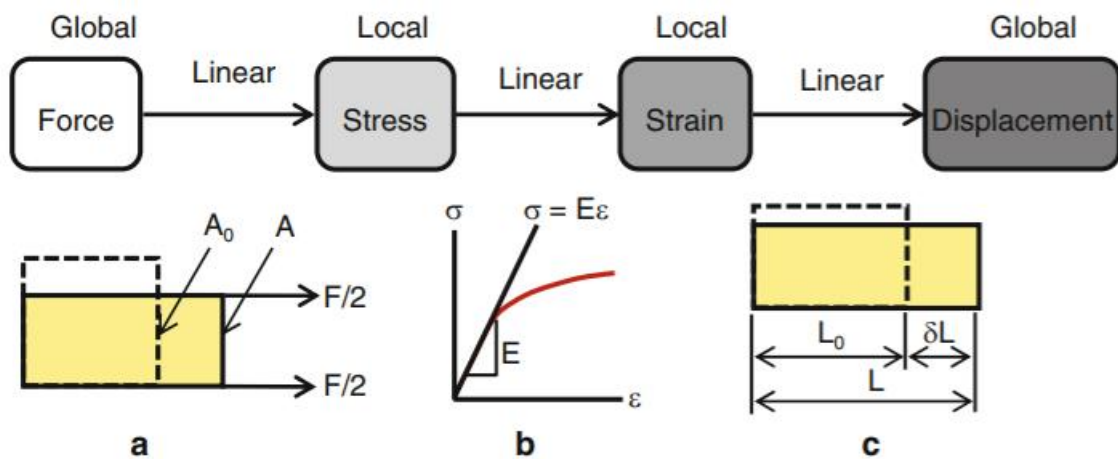

Figure 2-2: Linear steps in structural systems [6]

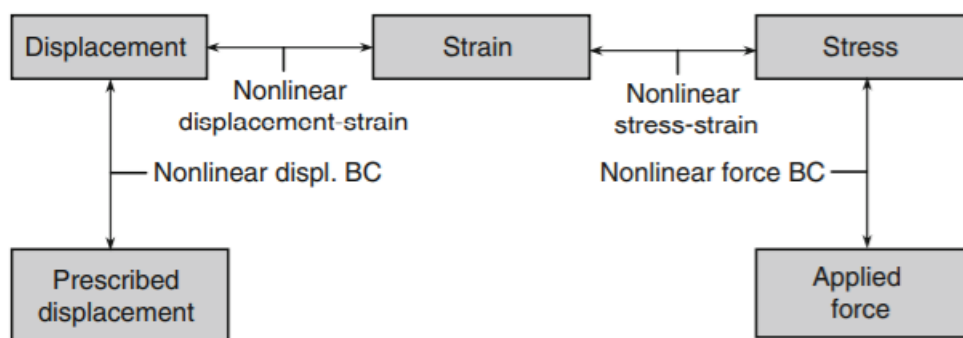

Figure 2-3: Non-linear steps in structural systems [6]

### 2.2.1 Geometric non-linearity

Geometric non-linearity is based on the deformations of an elastic body [8]. According to Kim [6], geometric non-linearities represents the cases when the relations among displacement, rotation and strains are non-linear. Cook [7] states that in geometric non-linearity, deformation is large enough that equilibrium equations must be written with respect to the deformed structural geometry. A practical example which demonstrated geometrical non-linearity is a fishing rod as shown in Figure 2-4. In the figure, it is obvious that the relation between the applied force and tip displacement are non-linear. However, if infinitesimal changes are assumed, the problem could be assumed linear, and the strain can be explained with the equation:

$$\epsilon(x) = \frac{du(x)}{dx}$$

For the fishing rod, the displacement and its gradient are not infinitesimal. Therefore, an additional term in the second order must be added to the equation above. Figure 2-5 displays the difference between the linear and non-linear strain. For infinitesimal changes, the difference is neglectable, but as the changes alter, so does the difference between the two models.

$$E = \frac{du}{dx} + \frac{1}{2} \left( \frac{du}{dx} \right)^2$$

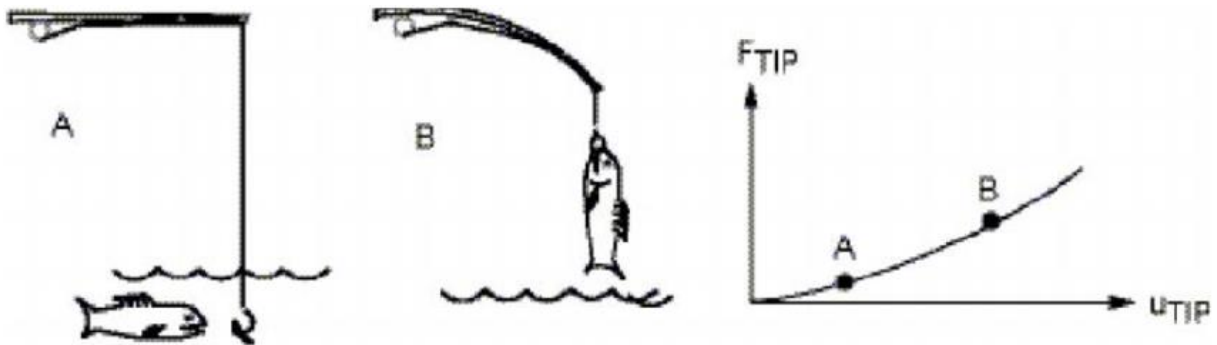

Figure 2-4: Fishing rod as a practical example of geometric non-linearity. [9]

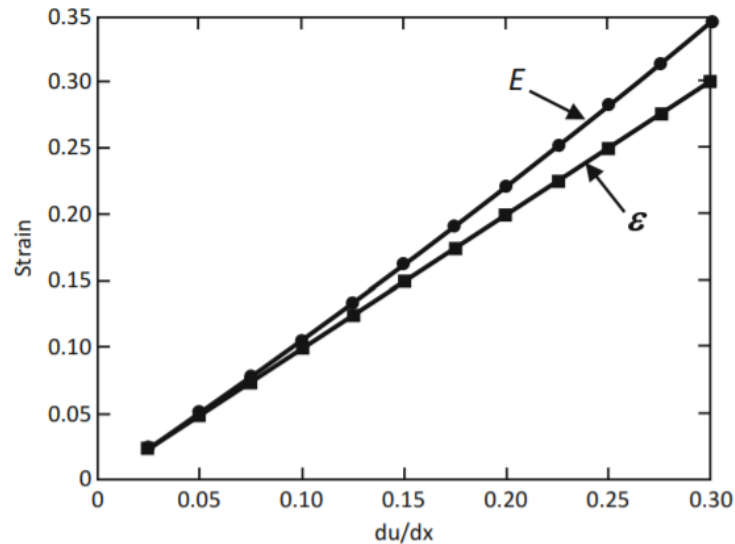

Figure 2-5: Linear and non-linear strain [6]

Geometric non-linearity can be applied to structures through several higher order theories. The higher order models can be added as expansions to the Taylor-like polynomials in the strain equations [10].

In structural engineering, second order analysis is furthest developed as it is sufficient for most structural engineering applications [5]. It is applied in theories as Euler's theory of beam buckling and plate buckling, as well as utilized for local checks in the Eurocodes. The consequences of second order theory applied to a simply supported beam are shown in Figure 2-6. With linear theory, the system is checked for equilibrium in the undeformed shape. Forces  $q$  and  $F$  are decoupled and forms bending moment and shear force, and normal force respectively. Calculated with second order theory, equilibrium is proved in deformed shape, and the loads  $q$  and  $F$  both forms bending moment as  $F$  now has a moment arm  $w$  at any position of the deformed beam. Hence, the second order model experience different bending moments than the first order, depending on compressive or tensional  $F$ .

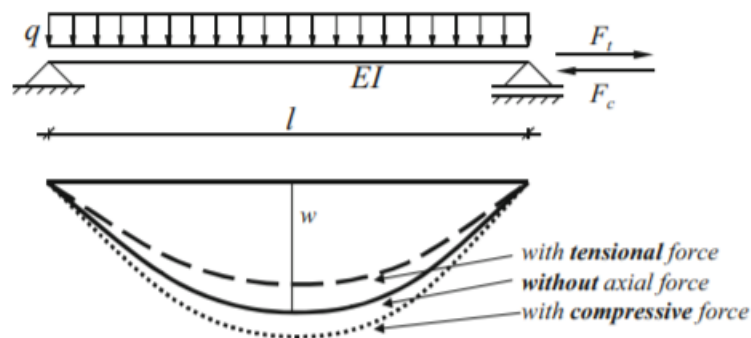

Figure 2-6: Consequence of equilibrium in deformed shape [5]



## 2.2.2 Material non-linearity

Material non-linearity is present when the stress and strain relationship of the material properties are not linear [6]. In structural systems it includes behaviour as non-linear elasticity, plasticity and creep [7]. The linear form of stress-strain relationship, e.g. the generalised Hooke's Law, is shown in equation below.

$$\sigma = E \cdot \epsilon$$

For non-linear systems, the elasticity modulus,  $E$ , is no longer constant. The difference can be illustrated in stress-strain diagrams as shown by Kim in Figure 2-7. In (a), the difference in linear and non-linear is obvious, with the straight line compared to the curved line. (b) illustrates plasticity, and (c) illustrated viscoelasticity.

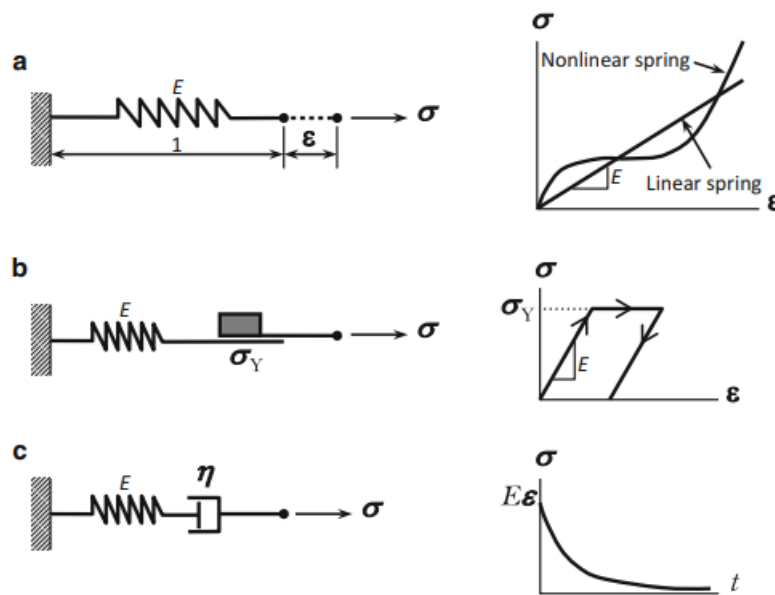

Figure 2-7: Non-linear material models. (a) Linear and nonlinear elastic spring models. (b) Elasto-plastic spring models. (c) visco-elastic spring models. [6]

## 2.2.3 Application of non-linearity

As the nonlinear relations have internally dependent terms, the solution methods applicable are all iterative [6]. Generally, the methods start with an initial estimate and finding an increment with linear equations and linearization. After the first increment is found, the solution is iteratively updated until a point of satisfactory convergence. There are several methods commonly employed to solve non-linear systems, with the method being different in the way of calculating the increment.

**Newton-Raphson Method** is a common method in numerical analysis to find the roots of non-linear equations [6]. The general method described above are applied, with its way of calculating the increment being characteristic of Newton-Raphson. The non-linear equations are locally approximated linearly to find the increment. The linear calculations are repeated until the output satisfies the original non-linear equations. Figure 2-8a displays Newtons-Raphson method applied to an elastic spring. The force,  $P$ , is causing a displacement  $u$ . The method is performed by starting at  $u=0$  and applying a load. The increment is calculated with the help of an initial tangent stiffness. This results in an estimate,  $u_a$ , of the correct result,  $u_1$ . The next step is performed by using the tangent from the first estimate and calculating the new increment. By following this procedure, the error is lowered for each step until a satisfactory convergence is reached. This method is not guaranteed to converge for all non-linear problems but are commonly used

to reach a satisfactory result. When  $u_1$  is reached, a new load increment can be added, and the iterations process starts from the first displacement  $u_1$  [7].

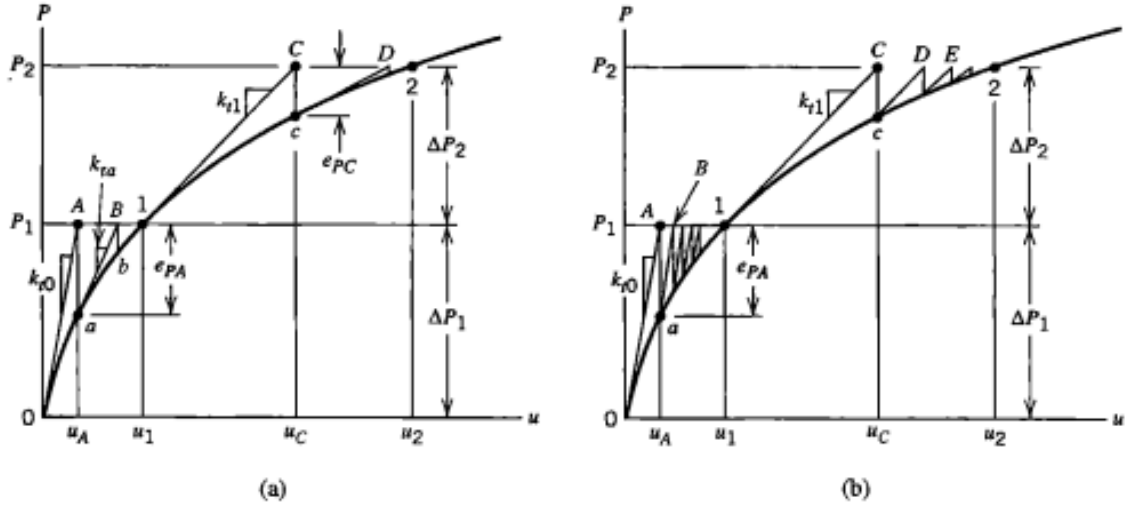

Figure 2-8: Illustration of the different iteration procedures at a) Newton-Raphson and b) Modified Newton-Raphson [7]

**Modified Newton-Raphson Method** differ from Newton-Raphson by its way of calculating the increment. Instead of continuously updating the tangent stiffness prior to each increment calculation, the same is used in several iterative cycles. Figure 2-8b displays the Modified Newton-Raphson. This method allows for easier calculations, and less use of data when using software for calculations. For multidimensional systems this modification can save engineers computational cost, as the stiffness matrix is kept for several steps, only updated occasionally [7].

## 2.3 Materials

Materials used in a pre-stressed concrete bridge are concrete, reinforcing steel and pre-stressing steel. Structural analyses and design depend on the properties and behaviour of the constituent materials [1]. A structure's capacity against failure is decided by calculations of the materials' strength and strain characteristics [11]. Hence it is necessary to know the ultimate strengths of both concrete and steel.

The material models used in analyses are based on the materials' strain characteristics. Standard assumptions made in structural mechanics are that concrete and reinforcing steel are fully bonded and behaving linear elastic [11]. This means that the materials are experiencing the same strain values and that Hooke's law is valid. The stress-strain relation is further used to determine displacements caused by exciting loads.

### 2.3.1 Concrete

Concrete has a complete non-linear stress-strain relation in compression and a considerably lower capacity in tension compared to compression [11]. Figure 2-9 displays typical stress-strain curves for different concrete classes under uniaxial compression. Notable here are the increase of tensile strength with the increasing compressive strength and the difference in ductility between high and low strength concrete. High concrete classes have notably lower ductile characteristics than low concrete classes. For traditional capacity calculations, the stress-strain curves are idealized as shown in Figure 2-10 from Eurocode 2. The idealized relation makes calculations easier and more secure as the curves are based on the concrete design strength,  $f_{cd}$ , which includes a partial factor of safety, a material coefficient, that takes uncertainties and variation in the characteristic strength into account. The characteristic strength and mechanical properties are shown in Table 2-1 (equivalent to table 3.1 in EC2).

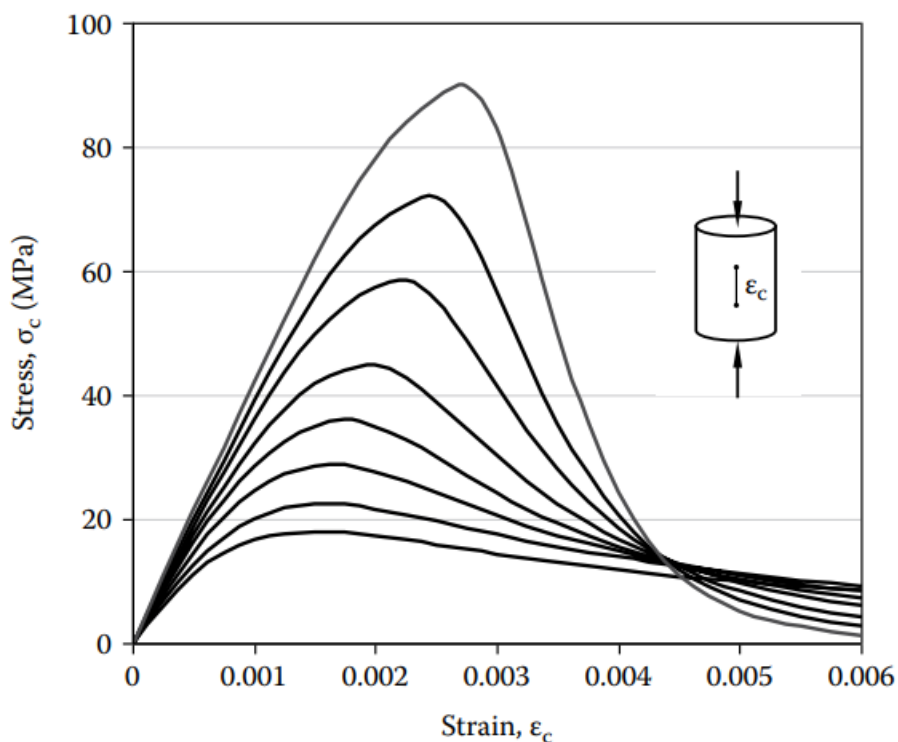

Figure 2-9: Typical stress-strain curves for concrete under uniaxial compression. [1]

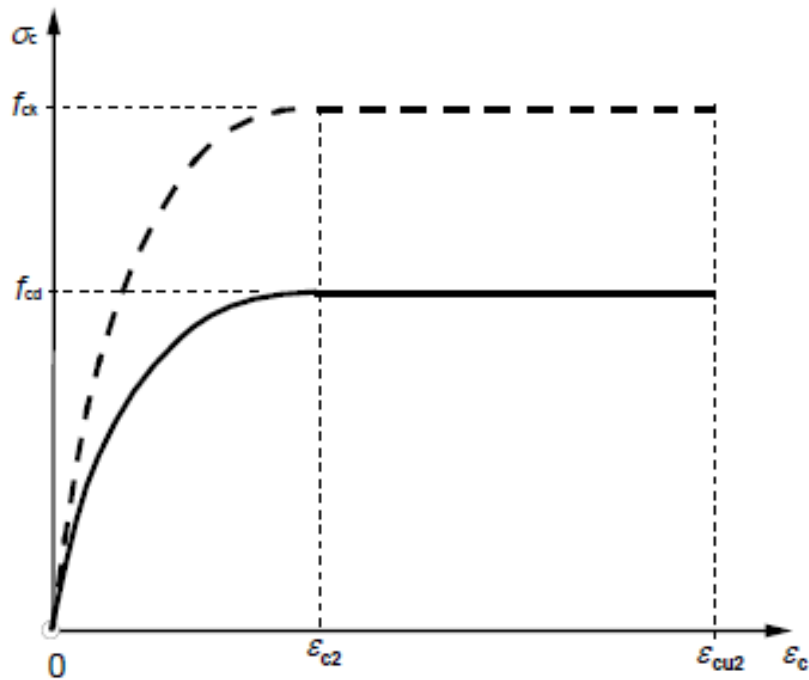

Figure 2-10: Idealized stress-strain curve for concrete in compression. [3]

Table 2-1: Strength and deformation characteristics of concrete. [1]

Strength class	C12/15	C16/20	C20/25	C25/30	C30/37	C35/45	C40/50	C45/55	C50/60	C55/67	C60/75	C70/85	C80/95	C90/105
$f_{ck}$ (MPa)	12	16	20	25	30	35	40	45	50	55	60	70	80	90
$f_{ck,ckb}$ (MPa)	15	20	25	30	37	45	50	55	60	67	75	85	95	105
$f_{cm}$ (MPa)	20	24	28	33	38	43	48	53	58	63	68	78	88	98
$f_{cm}$ (MPa)	1.6	1.9	2.2	2.6	2.9	3.2	3.5	3.8	4.1	4.2	4.4	4.6	4.8	5.0
$f_{ck,0.05}$ (MPa)	1.1	1.3	1.5	1.8	2.0	2.2	2.5	2.7	2.9	3.0	3.1	3.2	3.4	3.5
$f_{ck,0.95}$ (MPa)	2	2.5	2.9	3.3	3.8	4.2	4.6	2.9	5.3	5.5	5.7	6.0	6.3	6.6
$E_{cm}$ (GPa)	27	29	30	31	33	34	35	36	37	38	39	41	42	44
$\epsilon_{cl}$ ( $\times 10^{-3}$ )	1.8	1.9	2.0	2.1	2.2	2.25	2.3	2.4	2.45	2.5	2.6	2.7	2.8	2.8
$\epsilon_{cu1}$ ( $\times 10^{-3}$ )					3.5					3.2	3.0	2.8	2.8	2.8
$\epsilon_{c2}$ ( $\times 10^{-3}$ )					2.0					2.2	2.3	2.4	2.5	2.6
$\epsilon_{cu2}$ ( $\times 10^{-3}$ )					3.5					3.1	2.9	2.7	2.6	2.6
$n$					2.0					1.75	1.6	1.45	1.4	1.4
$\epsilon_{cl}$ ( $\times 10^{-3}$ )					1.75					1.8	1.9	2.0	2.2	2.3
$\epsilon_{cu3}$ ( $\times 10^{-3}$ )					3.5					3.1	2.9	2.7	2.6	2.6

Concrete will experience the effects of creep and shrinkage over time. Creep is an additional deformation that occurs when the concrete is compressed over a longer period [11]. Practically, this means that all structures with no direct support will eventually creep because of its self-weight. Shrinkage is a result of concrete hardening and water evaporation. The autogenous shrinkage is a chemical process which happens gradually when water binds with cement, with largest effects in the early hardening phase. Drying shrinkage happens when the hardened concrete is exposed for a dry environment and the surface dries out. This leads to water evaporation from the pores within the concrete and will gradually lead to shrinkage of the structure which eventually could crack. Shrinkage is autonomous and independent of loads. Both creep and shrinkage add extra strain to the stress-strain relationship in concrete and leads to loss in pre-stressing force.

The development of strain in a concrete specimen is shown in Figure 2-11 and shows that the deformations is both instantaneous and time dependent [1]. Shrinkage occurs as the concrete starts to set and gradually decrease over time. When loaded, the concrete experience both an instantaneous deformation, in addition to the start of the creeping mechanism. In addition, the concrete is at any time subjected to temperature strains which varies with time. The temperature strain, however, is often neglected in concrete tests, as the specimen is held at a constant temperature, as is the case in Figure 2-11.

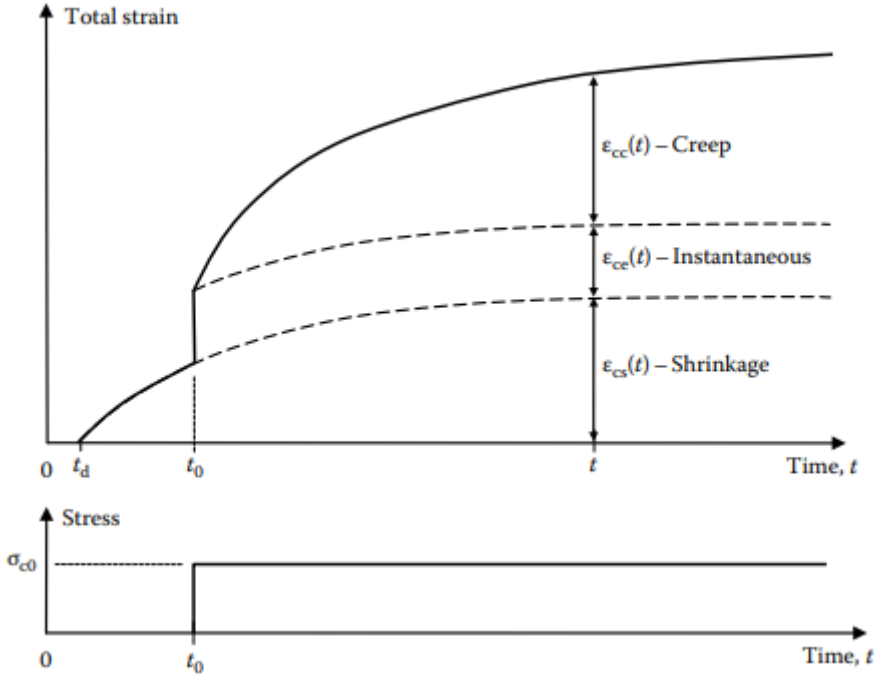

Figure 2-11: Concrete strain versus time for a specimen subjected to constant sustained stress. [1]

Increased axial deformation and curvature on reinforced and prestressed concrete cross-sections, losses of prestress, local redistribution of stress between concrete and reinforcement and redistribution of internal actions in statically indeterminate members are caused by creep and shrinkage. Creep and shrinkage can also cause excessive deflection and shortening of prestressed members. Shrinkage may also lead to cracking of the concrete, which may affect the structure serviceability and durability. Creep, however, reveals a measure of deformability in concrete, as it relieves concrete of stress distributions.

At high stress-levels, higher than half the concrete compressive strength, both the instantaneous and creep strain become non-linear. However, the applied stress rarely reaches these high levels, and both can be assumed linear elastic. Creep caused by tensile stresses appears to behave differently than under compression, with the tensile creep being more linear and not decreasing in the same manner. Though for the same low stress levels, the rate and magnitude can be assumed similar. Also, in ULS, the tensile strength of concrete is not accounted for [12].

Calculations of the time-dependent behaviour require an accurate estimation of each strain component at critical locations, as well as knowledge of the concrete member's stress history and material properties [1]. Reinforcement and support conditions also complicate predicting the behaviour. Therefore, great accuracy in the calculations of the creep capacity and shrinkage strain is not feasible. In design, predictions are made using numerical models.

Concrete used in pre-stressed structures are usually of higher strength class than ordinary reinforced concrete structures. Most common strength classes are in between 35 and 65 MPa, but higher classes are also used [11] [1]. Pre-stressing of concrete lead to high applied compressive force at the concrete and is a main reason for the higher strength class. Generally, high strength concrete creeps less than lower strength, which results in smaller losses of pre-stressing force [1]. Also, a concrete with low water-cement ratio is important to prevent corrosion to the relative easily corroded pre-stressing steel [11].

Figure 2-12 shows the idealised compressive stress-strain curve for non-linear structural analyses specified in Eurocode 2. The stress-strain relation is for short-term uniaxial loading and can be expressed with the equation:

$$\frac{\sigma_c}{f_{cm}} = \frac{k\eta - \eta^2}{1 + (k - 2)\eta}$$

Where  $\eta = \epsilon_c / \epsilon_{c1}$  and  $k = 1,05 E_{cm} \cdot |\epsilon_{c1}| / f_{cm}$ . The parameters  $f_{cm}$ ,  $E_{cm}$  and  $\epsilon_{c1}$  are found in Table 2-1. The equation is valid for  $0 < |\epsilon_{c1}| < |\epsilon_{cu1}|$ , where  $\epsilon_{cu1}$  is the nominal strain limit corresponding to the ultimate strength. Eurocode 2 states that other ideal stress-strain relations can be utilized if adequately representing the behaviour of the concrete in question [12].

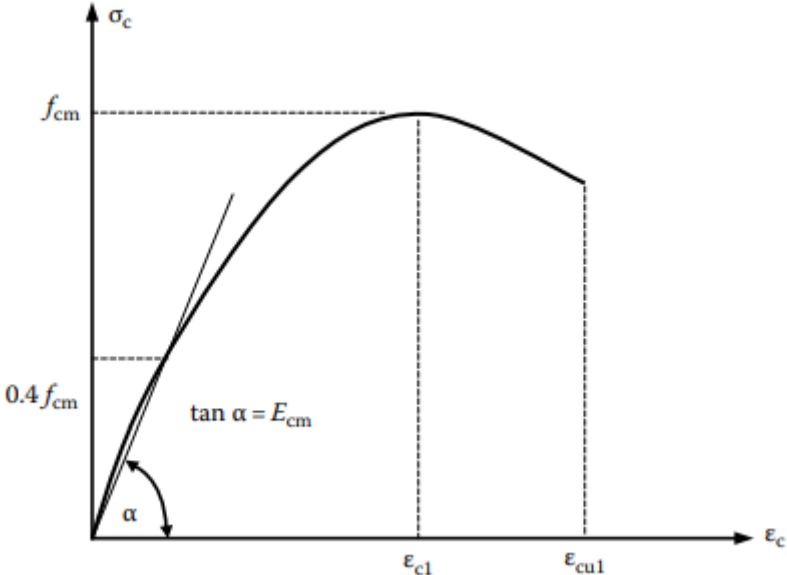

Figure 2-12: Idealised stress-strain relationship for concrete in uniaxial compression [12]

### 2.3.2 Reinforcing steel

Steel reinforcement is used in concrete to provide additional tensile strength, ductility and serviceability, but can also reduce immediate and time-dependent deformations and provide crack control if strategically designed [1]. Regular reinforcing steel is hot-rolled carbon steel bars with rib-shaped deformations on its surface. The ribs help the steel bond properly with the concrete and improves the anchorage potential of the bar. The most common steel quality is B500NC, with the number 500 representing its characteristic yield value,  $f_{yk}$ , in MPa. Regular E-modulus for this steel is 200 GPa. Figure 2-13 shows a typical stress-strain curve for reinforcing steel. The steel is usually assumed to be elastic plastic in design calculations, with the strain hardening often ignored. The ultimate characteristic,  $\epsilon_{uk}$ , and design,  $\epsilon_{ud}$ , strain can also be seen in the figure. Design strain for B500NC is  $\epsilon_{ud} = 3,0\%$ .

Regular steel reinforcement is also used together with prestressing steel. It supplements the pre-stressing steel and provides the same properties as in ordinary reinforced concrete.

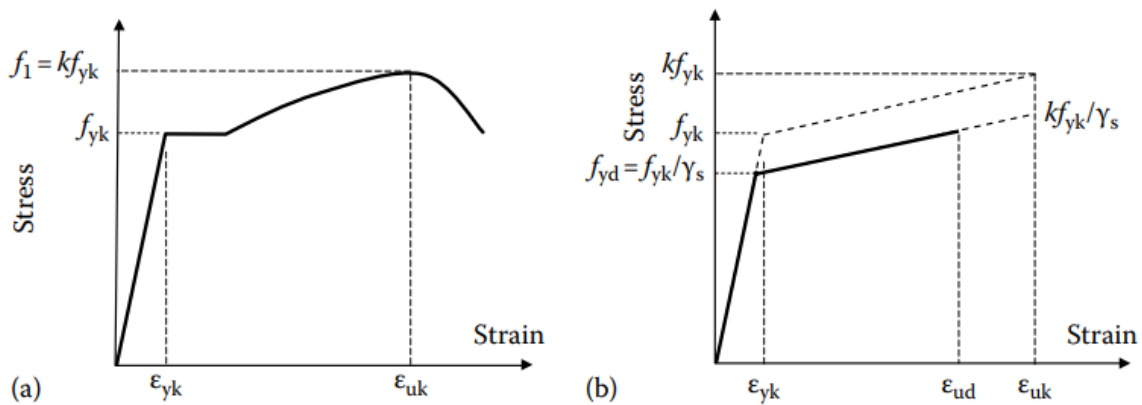

Figure 2-13: a) Actual and b) idealised stress-strain curves for reinforcing steel. [1]

### 2.3.3 Prestressing steel

To achieve complete pre-stressing of a structure, i.e. no tensile stresses in service limit state, it is necessary to use high strength steel [11]. Loss in pre-stressing force is inevitable as the concrete creeps and shrinks, and the steel experiences relaxation. With the elasticity modulus being somewhat the same for pre-stressing and reinforcing steel, the loss in pre-stressing force will be less in per cent for higher strength steel. Therefore, the pre-stressing steel must be able to withstand a high initial stress, often in between 1000 and 1900 MPa [1].

Steel used for pre-stressing are usually a combination of cold-rolled and alloying, in form of tendons, consisting of round wires, strands or bars [1] [11]. High strength steel has no defined yield value as regular reinforcing steel, as shown in Figure 2-14, and is considerably less ductile. For design purposes, the yield stress,  $f_{p0.1k}$ , is usually defined as the stress corresponding to 0.1% offset strain [1]. This is generally 0.8-0.88 times the strength of the tendon, the characteristic breaking strength,  $f_{pk}$ . As regular practice in Eurocodes, the tendon yield stress is multiplied with a material coefficient for the tendon design strength. As with concrete and ordinary reinforcement, pre-stressing steels also have idealized stress-strain curves that are used in design.

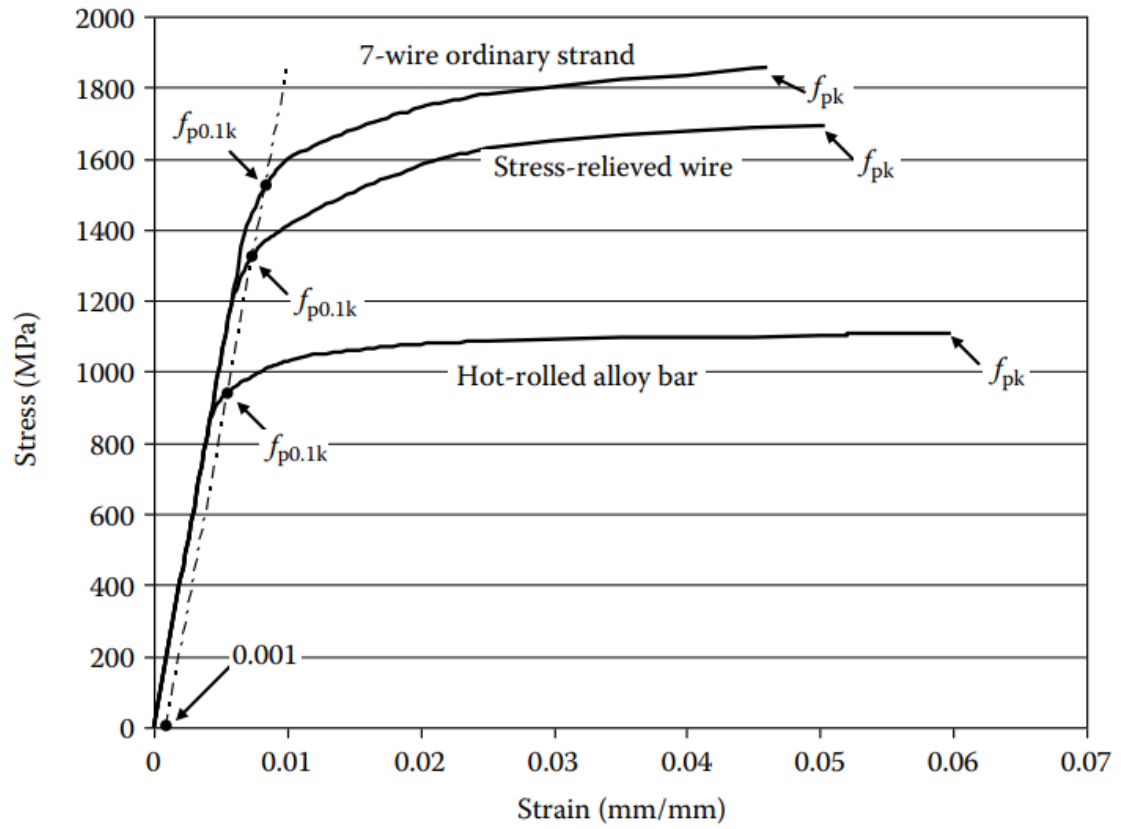

Figure 2-14: Typical stress-strain curve for tendons. [1]



## 3. Analysis and design guidelines

### 3.1 Analysis and design approach

#### 3.1.1 Partial factor of safety / limit state

The Eurocodes in structural analyses employ limit state design applied by the partial factor of safety method [3]. Generally, a structure shall be designed to withstand any possible load or load combination reasonable to be applied under construction and in-use during its designed lifetime with sufficient reliability. A structure shall be designed to have sufficient capacity, serviceability and durability. These requirements are firstly considered in the structural modelling, when choosing the structural geometry and materials. The reliability is satisfied by designing in regard to the Eurocodes, quality in constructing phase and quality assurance.

The two primary design objectives, strength and serviceability, are carried out in the analysis by the two limit states, Ultimate Limit State (ULS) and Service Limit State (SLS) [13]. The limit states are defined by design criterions of which the structure must satisfy. A structure must be designed to satisfy the design criteria's in both limit states as they are independent of each other and validates the structure for different requirements [3]. The ultimate limit state secure that the structures have sufficient capacity, while service limit state secure the serviceability.

Limit state design is based on simplified models of the structure, loads and calculations [3]. To secure safe structures and eliminate uncertainties, a partial factor of safety is applied where necessary, most importantly to material properties and loads [13]. The partial safety factor for materials takes the statistical variability of the characteristic strength properties and material modelling into account. A materials characteristic strength value is a probabilistic found low value that does not exceed a 2-5% probability of failure. The partial safety factor for loads takes the possible deviation of the actual loads from the characteristic loads into account, with an annual probability of being exceeded typically from  $10^{-4}$  to  $10^{-2}$ . The partial factors of safety differ in the various limit states, depending on which criteria are being checked. This method results in design values with very low, but unknown, probability of being exceeded. Figure 3-1 displays the philosophy of partial factor design. **S** represent the applied load and **R** represent the structural strength.

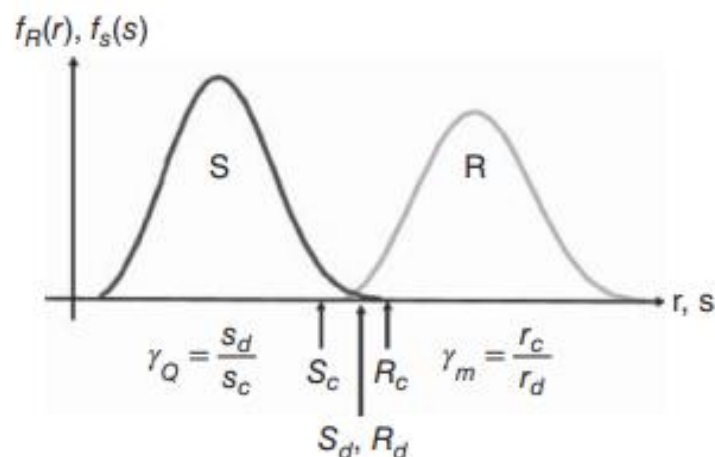

Figure 3-1: Illustration of partial factor design philosophy. [13]

### 3.1.2 Simulation based approach

In traditional design, non-linear analysis is implemented in local checks and special situations where the linear elastic assumptions are not satisfactory accurate, in example in analyses of deep beams, complex soil-structure interactions or effects of the imposed deformations [14]. As non-linear analysing methods are becoming more available, such analysis procedures are added to a new Eurocode 2. According to the draft, non-linear analyses can be performed by numerical solutions to verify a structure regarding ultimate limit states. It specifies that the software used for non-linear verification must be properly validated by comparison between the numerical solution and experimental or benchmark results. Examples of possible experimental or benchmarks tests are material models, identification of relevant failure modes, mesh sensitivity and solution method parameters in methods like Newton-Raphson etc.

Non-linear verification of ultimate limit states requires, similar to the linear analyses, that the design value of combined actions must not be greater than the design value of the structural resistance. To obtain a design value of the structural resistance, several safety formats can be used, including the partial factor method. Other possible formats are the global factor method or the structural reliability analysis of a full probabilistic method.

To perform a non-linear analysis, iterative numerical solution must be used. As the non-linear behaviour is unpredictable, more thorough testing and validation of the simulation results are required to consider the results reliable in comparison with linear behaviour. In addition, a safety method is applied to ensure safe structures and eliminate uncertainties, similarly as in linear analyses.

### 3.2 Design guidelines

Construction of concrete structures are subject to several regulations. In Norway the governing legislation is "Plan og bygningsloven" (The Planning and Building Act) including the technical regulations "Forskrift om krav til byggverk og produkter til bykkverk – TEK" (Regulation regarding requirements to Building and Products to Buildings) and "Forskrift om saksbehandling og kontroll i byggesaker(SAK)" (Regulations regarding executive work and control in buildings) [15]. Also important for bridge design is "Vegloven" (Act related to road constructions). Acts and regulations are formulated in general means, not for direct practical usage. However, standards and other guidelines need to fulfil the acts and regulations in order to be valid in its country. Standards are not legislative but offers the user a safe and tested solution for its structure which fulfils all given acts and regulations and are therefore recommended to use.

Road bridges are regulated by Norwegian Public Road Administration (SVV) and are subject to SVV's regulations and guidelines with authorization in the Act related to road constructions.

Below are all design guidelines and manuals used in this report. The guidelines used directly in the report is also included in the references.

Eurocodes:

- NS-EN 1990:2002+A1:2005+NA:2016: Eurocode: Basis of structural design. Referred to as EC0
- NS-EN 1991-1-1:2002+NA:2019: Eurocode 1: Actions on structure, Part 1-1: General actions, Densities, self-weight, imposed loads for buildings. Referred to as EC1-1
- NS-EN 1991-1-5:2003+NA:2008: Eurocode 1: Actions on structures, Part 1-5: General actions, Thermal actions. Referred to as EC1-5
- NS-EN 1991-2:2003+NA:2010: Eurocode 1: Actions on structures, Part 2: Traffic loads on bridges. Referred to as EC1-2
- NS-EN 1992-1-1:2004+A1:2014+NA:2018: Eurocode 2: Design of concrete structures, Part 1-1: General rules and rules for building. Referred to as EC2
- NS-EN 1992-2:2005+NA:2010: Eurocode 2: Design of concrete structures, Concrete bridges, Design and detailing rules. Referred to as EC2-2

Eurocode draft:

- EN 1992-1-1 Eurocode 2: Design of concrete structures – Part 1-1: General rules – Rules for buildings, bridges and civil engineering structures

National Manuals and guidelines

- N400 "Bruprosjektering" (Bridge Design) from SVV. Referred to as N400
- SVV Report nr. 668: "Beregningsveiledning for etteroppspente betongbruere". (Calculation guidelines for post-tensioned concrete bridges)
- R412 "Bruklassifisering" (Bridge classification) from SVV

### 3.3 Loads and load combinations

This chapter describes the process and establishment of the relevant loads at a prestressed concrete bridge, excluding wind, accident and eccentric traffic loads. SVV's manual N400 and EC1-x are used in calculations. Most loads are calculated as uniformly distributed (kN/m) with some exceptions as point loads (kN).

Loads are classified by their variation in time as permanent, variable and accident loads. The characteristic value of the excitation is used in calculations of the loads.

#### 3.3.1 Permanent loads

Loads which are considered constant or approximately constant at the structures design life are called permanent loads [16]. Self-weight, extra weight due to railings or smaller parts of the construction that are not to be removed, water pressure and earth pressure are all considered permanent loads.

##### Self-weight

For a bridge structure the main part of the self-weight is the bridge deck. Also contributing are elements like parapet walls, railings and added layers like asphalt and insulation. Table 3-1 shows the characteristic self-weights with references.

Table 3-1: Characteristic self-weights

Element	Self-weight	Reference
Reinforced concrete	25 kN/m <sup>3</sup>	N400, 7.3.2
Asphalt	2,0 - 3,5 kN/m <sup>2</sup>	N400, table 5.1
Pedestrians	1,5 – 2,0 kN/m <sup>3</sup>	N400, table 5.2
Railings	0,5kN/m	R412, page 34

#### 3.3.2 Variable Loads

Loads which has time-varying excitement are considered variable loads. Such are loads due to traffic, the environment and others, such as loads during construction or maintenance or other operations on the structure.

### 3.3.3 Temperature Loads

Thermal loads occur in concrete structures because of changes in surrounding temperatures causing the material to expand or contract, depending on rising or sinking temperature respectively. These thermal effects are divided into following categories in bridge design [17]:

- Uniformly distributed temperature
- Vertical linear or nonlinear changing temperature
- Horizontal linear changing temperature
- Difference in uniformly distributed temperature in members
- Difference in temperature across the wall thickness in a box section

Thermal loads are calculated according to NS-EN 1991-1-5 and N400.

#### Uniformly distributed temperature

The loading effects from the uniformly distributed temperature is the effect causing expansion and contraction of a bridge deck if not restrained. It depends on the lowest and highest expected temperature at the specific site. The expected  $T_{max}$  and  $T_{min}$ , the highest and lowest air temperature, are found as isotherms in the national annex of the standard in figure NA.A1 and NA.A2.

Bridges are divided into categories depending on the main material, concrete bridges are in category 3.  $T_{e,min}$  and  $T_{e,max}$ , the expected highest and lowest uniformly distributed temperature of the bridge surface, are calculated according to figure NA.6.1 depending on the bridge type. For concrete bridges these are:

$$T_{e,max} = T_{max} - 3$$

$$T_{e,min} = T_{min} + 8$$

Further, two intervals of temperatures giving maximum expansion and contraction can be calculated using the air temperature at the time of structure erection,  $T_0$ .  $T_0$  is given in the national annex and is normally set to 10°C. Then the two temperature intervals are as follows:

$$\Delta T_{N,con} = T_{e,min} - T_0$$

$$\Delta T_{N,exp} = T_{e,max} - T_0$$

#### Vertical temperature change

During its lifetime, a bridge deck will undergo large changes in temperature, from maximum heating to maximum cooling, resulting in varying temperature situations across the cross section. This report will consider linear varying temperature only, as this is regular practise for concrete bridges (TYPE 3). With the vertical changing temperature across the cross section, the expansion and contraction of the structure member will change thereafter. The member expands in the warmest direction, causing curvature at that side. Vertical temperature differences can cause load effects on a structure if the structure is restrained any buckling or from friction in the rotational supports, which both denies this curving of the member. The Eurocode divides it into top surface warmer than bottom,  $\Delta T_{M,heat}$ , and bottom surface warmer than top,  $\Delta T_{M,cool}$ . Recommended values are found in table NA.6.1. but could be altered depending on the thickness of additional layers at the bridge deck. The default thickness is 50mm in EC1-1-5, but a correction factor,  $k_{sur}$ , is available in table NA.6.2 for different layer thickness.

### Conjunction of uniform temperature and temperature variation

For frame structures as bridges, a premise of conjunction of both uniformly distributed and vertically changing temperature must be considered. The following load cases is then present of which the most unfavourable combination should be chosen. These load cases result in eight possible combination, showed in Table 3-2.

$$\Delta T_{M,heat} \text{ (or } \Delta T_{M,cool}) + \omega_N \cdot \Delta T_{N,exp} \text{ (or } \Delta T_{N,con})$$

$$\omega_M \cdot \Delta T_{M,heat} \text{ (or } \Delta T_{M,cool}) + \Delta T_{N,exp} \text{ (or } \Delta T_{N,con})$$

Where  $\omega_N=0,35$  and  $\omega_M=0,75$ .

**Table 3-2: Load combinations of traffic loads**

Combination nr.	$\Delta T_{M, heat}$	$\Delta T_{M, cool}$	$\Delta T_{N, exp}$	$\Delta T_{N, con}$
1	1,0		0,35	
2	0,75		1,0	
3	1,0			0,35
4	0,75			1,0
5		1,0	0,35	
6		0,75	1,0	
7		1,0		0,35
8		0,75		1,0

### 3.3.4 Traffic loads

Traffic loads are calculated according to NS-EN 1991-2:2003 + NA:2010. The load effect is caused by any vehicles driving over the bridge [18]. Load models suited to the location of the bridge are used to consider the various categories of vehicles, traffic density and other different parameters of vehicle traffic. The load models are representing the following traffic effects:

- LM1: Concentrated and uniformly distributed loads.
- LM2: A single axle load applied on specific tyre contact areas. The load case covers the dynamic effects of normal traffic on short structural members.
- LM3: Special, heavier vehicles. Simulated by a set of assembled axles.
- LM4: Larger gathering of people, only relevant for bridge near towns where effects are not included in LM1.

In design, the carriageway width,  $w$ , is divided into notional lanes and rest area according to table 4.1 in EC1-2. In the load models, the lanes are applied different load combinations, whereas the most unfavourable is to be chosen. LM4 will never be the most unfavourable model for small and medium size bridges [19], therefore LM1 and LM2 and LM3 are relevant.

#### Vertical traffic load: Load model 1

Load model 1 is used for general and local verifications, as it covers the most effects of traffic from lorries and cars. EC1-2 states that "LM1 is intended to cover flowing, congested or traffic jam situations with a high percentage of heavy lorries" [20]. It consists of two partial systems:

- The tandem system (TS), double-axle concentrated loads
- The UDL system, uniformly distributed loads

Figure 3-2 illustrates a situation for one lane only. A tandem system is placed in each lane, with different axle loads. The same applies for the UDL system, different loads are applied to the different lanes as shown in Figure 3-3 below. Figure 3-3 also shows the characteristic values, excluding adjustment factors, which are specified in the national annex. To decide LM1, several load cases are usually carried out, trying with the different combinations loads in the right, left and centre lane, to find the most unfavourable load case.

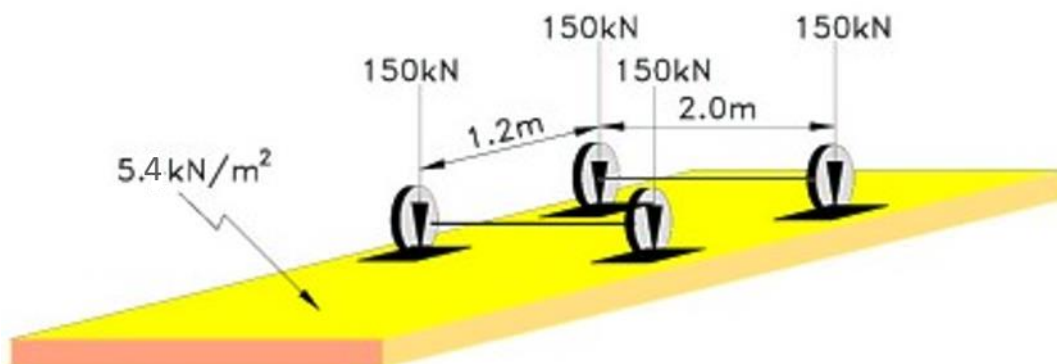
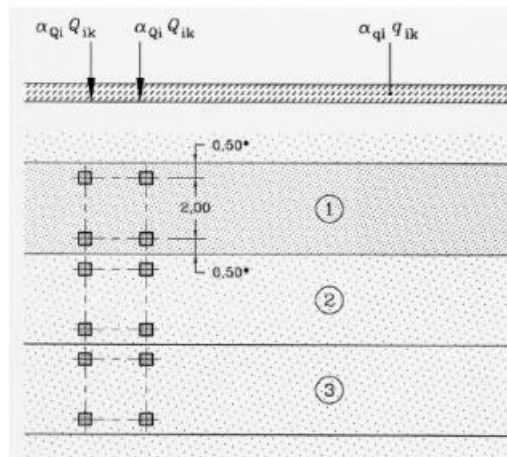

Figure 3-2: Illustration of LM1 applied to a lane. Gathered from [21] but changed from 5,5 to 5,4 which is correct according to NA.

Table 4.2 - Load model 1 : characteristic values

Location	Tandem system <i>TS</i>	<i>UDL</i> system
	Axle loads $Q_{ik}$ (kN)	$q_{ik}$ (or $q_{ik}$ ) (kN/m <sup>2</sup> )
Lane Number 1	300	9
Lane Number 2	200	2,5
Lane Number 3	100	2,5
Other lanes	0	2,5
Remaining area ( $q_{ik}$ )	0	2,5

The details of Load Model 1 are illustrated in Figure 4.2a.



**Key**

- (1) Lane Nr. 1 :  $Q_{1k} = 300$  kN ;  $q_{1k} = 9$  kN/m<sup>2</sup>
  - (2) Lane Nr. 2 :  $Q_{2k} = 200$  kN ;  $q_{2k} = 2,5$  kN/m<sup>2</sup>
  - (3) Lane Nr. 3 :  $Q_{3k} = 100$  kN ;  $q_{3k} = 2,5$  kN/m<sup>2</sup>
- \* For  $w_l = 3,00$  m

Figure 4.2a - Application of load Model 1

Figure 3-3: Details for LM1 from NS-EN 1991-2 [18]

**Vertical traffic load: Load model 2**

Load model 2 consists of a single axle load of 400kN applied anywhere on the carriageway [21]. The model includes factor for dynamic amplification. When relevant, effects under one wheel of 200kN should be considered. The contact surface of each wheel in LM1 and LM2 are different and corresponds to different tyre models. LM2 has a contact area of 0,35m times 0,60m for each wheel.

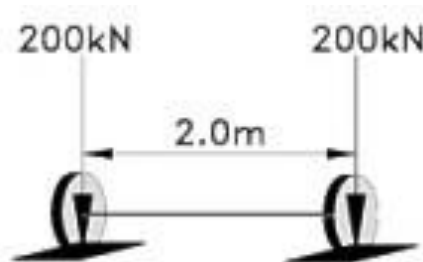

Figure 3-4: Illustration of LM2. [21]



### Vertical traffic load: Load model 3

Load model 3 accounts for one-time transportation of special vehicles. The load model consists of two separate load models of characteristic loads that are to be controlled. Two combinations of total load and axle load are controlled as shown in Table 3-3 [22].

Table 3-3: Characteristic loads, LM3

Total load	Axle composition, <i>n · axle line load</i>	Axle distances, <i>(n - 1) · e + 12+..</i>	Total length
2 700 kN	18 · 150 kN	17 x 1,50 m	25,5 m
4 500 kN	15 · 150kN + 15 · 150kN	14 · 1,50m + 12m + 14 · 1,50m	54,0m

Every axle line consists of two load planes lined with 0,3m distance and 0,15m x 1,20m plane area, resulting in the total width of 2,7m. The special vehicles are driven centrally across the bridge with a minimum eccentricity of +/- 0,3m. Breaking and acceleration forces are not to be included.

### Breaking and acceleration forces

A breaking force must be applied longitudinal, acting at the surface level to the carriageway. The breaking forces is limited to 900kN for the total width of the bridge. The placement and direction of the force should be chosen to the worst-case scenario. Breaking and acceleration force should be considered with the same magnitude only at opposite directions. The breaking and acceleration force is calculated as:

$$Q_{lk} = 0,6 \cdot \alpha_{Q1}(2Q_{lk}) + 0,10 \cdot \alpha_{q1} \cdot q_{lk} \cdot w_l \cdot L$$
$$180 \cdot \alpha_{Q1}[kN] \leq Q_{lk} \leq 900[kN]$$

Where L is the length of the deck or the part of it under consideration.

### Combination of forces

As the different load models may occur simultaneously, they are combined in groups as shown in Figure 3-5. The footnote a in the national annex and the table does not correspond, and therefore gr2 is not relevant since the horizontal forces are included in gr1a according to a calculation guidance from SVV [23]. For road bridges, gr1a is the dominating group for global analysis, while gr1b dominates in local checks of the bridge deck.

		CARRIAGEWAY					FOOTWAYS AND CYCLE TRACKS	
Load type		Vertical forces			Horizontal forces		Vertical forces only	
Reference		4.3.2	4.3.3	4.3.4	4.3.5	4.4.1	4.4.2	5.3.2-(1)
Load system		LM1 (TS and UDL systems)	LM2 (Single axle)	LM3 (Special vehicles)	LM4 (Crowd loading)	Braking and acceleration forces <sup>a</sup>	Centrifugal and transverse forces <sup>a</sup>	Uniformly Distributed load
Groups of Loads	gr1a	Characteristic values						Combination value <sup>b</sup>
	gr1b		Characteristic value					
	gr2	Frequent values				Characteristic value	Characteristic value	
	gr3 <sup>d</sup>							Characteristic value <sup>c</sup>
	gr4				Characteristic value			Characteristic value
	gr5	See annex A		Characteristic value				
Dominant component action (designated as component associated with the group)								
<sup>a</sup> May be defined in the National Annex (for the cases mentioned). <sup>b</sup> May be defined in the National Annex. The recommended value is 3 kN/m <sup>2</sup> . <sup>c</sup> See 5.3.2.1-(2). One footway only should be considered to be loaded if the effect is more unfavourable than the effect of two loaded footways. <sup>d</sup> This group is irrelevant if gr4 is considered.								

Figure 3-5: Assessment of groups of traffic loads. [18]

### 3.3.5 Deformation loads

Deformation loads are effects due to applied deformations or due to material properties, included prestressing forces, shrinkage, creep, relaxation, settlement or from loads during construction [16]. These are often time-dependent, and the characteristic load is defined as the largest expected force within the space of time considered. The material properties are elaborate in chapter Materials. Construction loads are not considered.

### 3.3.6 Load Combinations

Design load combinations are the assembly of characteristic loads to the combination of loads which are used in the design check [19]. Combination of loads are conducted by the partial factor method as presented in Eurocode: Basis of structural design. The partial factor method shall demonstrate that none of the relevant boundary states are exceeded in any of the relevant design situations when design values for loads, load effects and capacities are used in the calculation models [3]. Table NA.A2.1 in EC0 displays the partial factors for road bridges. If two or more loads are considered to often reach its maximum value at the same time or are strongly dependent on each other in respect of time and placement, they shall be considered as one combined load. Loads that cannot operate at the same time because of for example the physical situation will not be combined.

Structures are checked and designed to withstand load combinations in ultimate limit state (ULS) and service limit state (SLS).

**Ultimate limit state** demonstrates a structure's weaknesses in its static system. The static equilibrium should be established by displaying that the design stabilizing loads are equal or larger than the design destabilizing loads. Also, the capacity shall be proven equal or larger than the design load effect [3].

In ULS, three combination sets are checked, where the most unfavourable load case is used in design. The different sets are:

- Set A: EQU Global equilibrium.
- Set B: STR/GEO Capacity
- Set C: STR/GEO Safety towards soil failure

The basis ULS load combinations are the combinations regarding permanent or variable load effects. Equations 6.10, or effectively 6.10a and 6.10b, in EC0 gives different load effects which are calculated and checked towards the capacity of the structure at critical design situations.

In a full design check, load combinations regarding accidents and seismic design situations are calculated. These are not included in this report.

**Service limit state** is described in chapter 6.5 in EC0 and demonstrates that the structure fulfils every technical requirement for usage. A structure which has failed the service limit state has not fulfilled a defined criterion for usage. Such criteria are defined at each project, but typically are related to deflection, vibrations or horizontal displacements [3].

Load combinations in service limit state shall be applicable for the defined technical requirements. Three different combination are needed for a complete design check:

- Characteristic combination
- Frequent combination
- Quasi-permanent combination

Where the characteristic combination are used for irreversible boundary state, frequent for reversible, and quasi-permanent for long-term effects and the structures aesthetic appearance [3].

### 3.3.7 Non-linear analysis combinations

As the principle of superposition is not valid for non-linear analyses, the system matrices must be calculated for each load case. This means that every possible load case must be carried out. The permanent loads are active in each load case, but the variable loads must be tested both separately and in relevant combinations. The partial factor of safety is used in the same manner as in linear combinations.

## 4. Modelling in Sofistik

### 4.1 Sofistik

Sofistik is an advanced engineering software which are particularly directed at structural and civil engineering [24]. It has been continuously developed since 1987 and is now a sophisticated program, made up of a modular structure that provides general open interfaces and performs advanced finite element analyses. Figure 4-1 illustrates how the software is structured, with a database connecting all the different program modules which performs the various tasks in analyses and design. Each individual program module has its own manual with theoretical background and descriptions for possible input and output from the module. Most program modules can be utilized using both text files and graphical user interfaces.



Figure 4-1: Flowchart of Sofistik structure. [24]

Sofistik Structural Desktop (SSD) is the main program module which connects all other modules and interfaces. The module controls pre-processing, processing and post-processing. From here, the user navigates between graphical interfaces and text input files, before running the tasks and analysing the results. All tasks can be executed in Text editor tasks, "TEDDY", through its own programming language, CADINP-command language, which is the most powerful and most basic access method for the modular structure of the software. TEDDY has an integrated help system listing all possible commands for the selected program module. The graphical user interface SOFiPLUS(X), a built in AutoCAD interface, allows the user to enter its system graphically and define geometric structures and loads in a CAD-environment.

The pre-processing is mainly performed either in SOFiPLUS or TEDDY, or in a combination of both with SSD as the connecting module. Pre-processing includes material and cross-section selection, definition of the geometric system, prestressing system, loads and construction stages.

Processing is performed through SSD with TEDDY files that enables the selected analysis program modules. Linear, non-linear and dynamic analysis are some examples of possible analysis, as well as fluid and thermal analysis.

Post-processing and design are also performed through SSD. Design program modules are conducted through TEDDY or graphical user interfaces, and includes superposition, design of cross-sections, plates and shells. Post-processing is conducted through the interactive programs Result viewer and Graphics, which are graphical representation of the analysed finite element system.

A flow chart of the workflow in this project is shown in the next chapter.

## 4.2 Flow chart of analysing process

In this report, the following workflows is executed in design of the bridge models. Figure 4-4 shows the possible types of feedback Sofistik returns after a task is run. Figure 4-2 and Figure 4-23 shows the list of tasks used in each analysis. After a task is run, Sofistik returns a symbol which says if the task was run successful or not. If a warning occurs, the analysis continues to the next task, but the warning should be checked when the analysis stops and if necessary fixed. If an error occurs, the analysis stops immediately and must be fixed. After each task is run, successfully or not, a report is generated where the cause and the location in the code of the error or warning is specified. After fixed, the failed task, or the task fixed (not necessarily the same as some task are dependent on another), is run again. This procedure is carried out until satisfactory results.

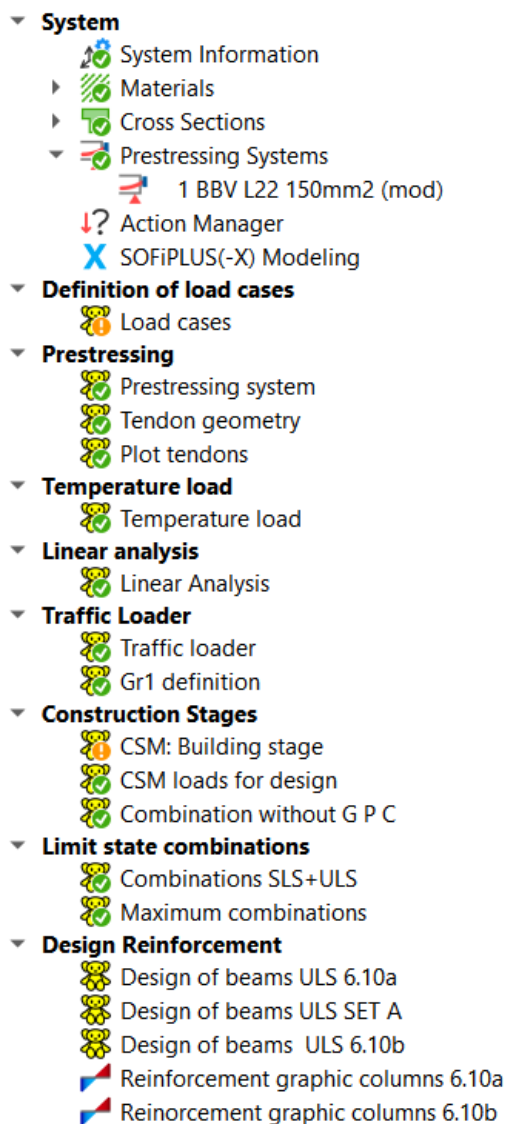

Figure 4-2: Workflow of linear analysis

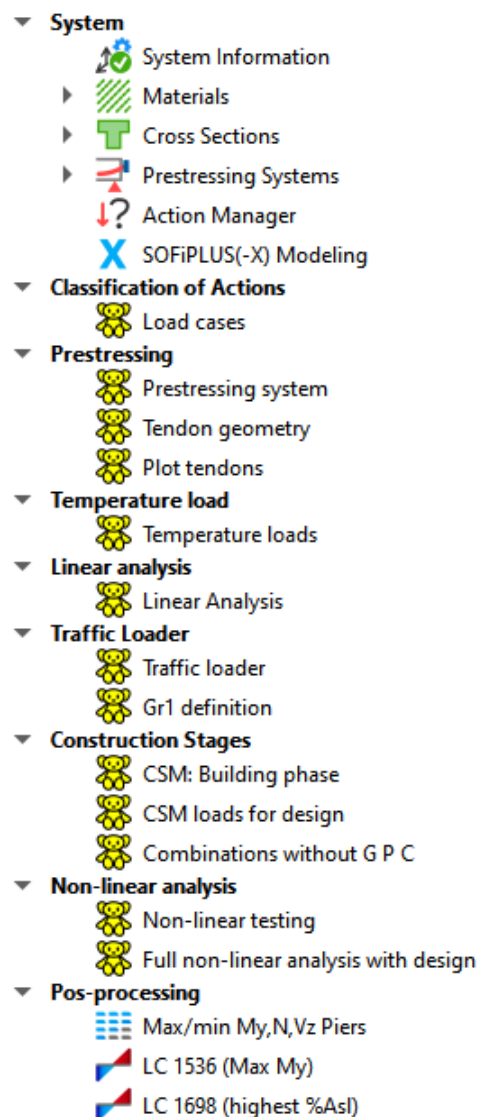

Figure 4-3: Workflow of non-linear analysis

## Run task



-  Task is successfully run
-  Check warning in report after ended run. Fix warning if necessary
-  Error: Task is stopped, check report, fix error and re-run task

Figure 4-4: Possible feedback-types after running a task

## 4.3 Theoretical principles

As mentioned, Sofistik is an advanced and sophisticated FEM software which has enormous possibilities and variants of problem solving. This chapter elaborates some important theoretical principles applied in the analyses and design procedures in this report.

### 4.3.1 ASE

ASE is the Sofistik program module for general static analysis of finite element structures [25]. The name is short for "Advanced Solution Engine", which hints that the module can solve complex and large problems. The module calculates the static and dynamic effects of general loading on any type of structure using the finite element method. It supports a large amount of element types, including beams, shells, springs, cables, trusses and brick(volume) elements

The program handles several types of supports and loads. Rigid and elastic supports are applicable, and could be applied to areas, lines and nodal points. Loads can be applied as nodal, lines and blocks, both at and independent of the selected mesh. ASE can account for construction stages, redistribution and creep effects through a primary load case which generates loads from stresses of a previously defined load case. The primary load case must be created in advance in another program module, in example in the construction stages.

ASE supports non-linear material analyses of three-dimensional elements and shell elements. Geometric non-linear analyses are available as investigations of 2nd and 3rd order theory effects of cable, beam, shell and volume structures.

ASE employs a displacement FEM method which calculates the unknowns from defined nodes. Displacements are obtained by interpolation per elements. The method is employed in four steps:

1. Determination of the element stiffness matrix.
2. Assembly of the global stiffness matrix and solution of the resulting equation system.
3. Application of loads and determination of the corresponding displacements.
4. Determination of the element stresses and support reactions due to the computed displacements.

The assembly of the global stiffness matrix and calculation of the resulting equations system are a demanding task and demand 90 percent of the total CPU time (or processing time). For a static linear system, this calculation is only demanded once. As the displacements are obtained through interpolation, the stresses "jump" from element to element, hence the quality of the FE analysis can be measured in the difference in stresses from element to element.

Sofistik AG specifies that analyses and calculations performed by ASE should be checked by approximate engineering calculations. The user should build experience through simple tasks and examples before analysing complex structures.



### 4.3.2 Non-linear analysis in ASE

ASE usually conducts non-linear analyses with the modified Newton-Raphson method, keeping a constant stiffness matrix [25]. In this way, ASE limits its computational cost, as the stiffness matrix is not decomposed for each step, and the system matrix always return positive determinants. The iterative process is enhanced through an acceleration algorithm designed by Crisfield. The method detects the developing residual forces and calculates coefficients for the displacement increments of the current and previous step. This method could be damped in the case of critical systems.

Geometric nonlinear analyses are conducted by a Line Search technique with a stiffness update. The Linesearch method reduce the load increment internally according to available residual forces. If the energy decreases in a proceeding step, a new tangential stiffness which enhances further iteration is generated, if necessary. For general cases according to first-order theory, including non-linear material analyses, Crisfield method is default. The iteration method, however, can be chosen by the user if desired, in example if experiencing convergence problems.

For truss, cable, spring, beam, quad and brick elements in a geometric non-linear analysis the iterations are significantly more stable when referring to a primary load case. In a geometric non-linear analysis of the elements the initial stress is added to the primary stress state, i.e. the ultimate load is calculated more precisely in this way. ASE can perform non-linear analyses using stress-strain curves accommodated for service limit state, ultimate limit state and with calculatonic mean values. The different stress-strain curves for concrete are shown in Figure 4-5. Material safety factors can easily be included/excluded.

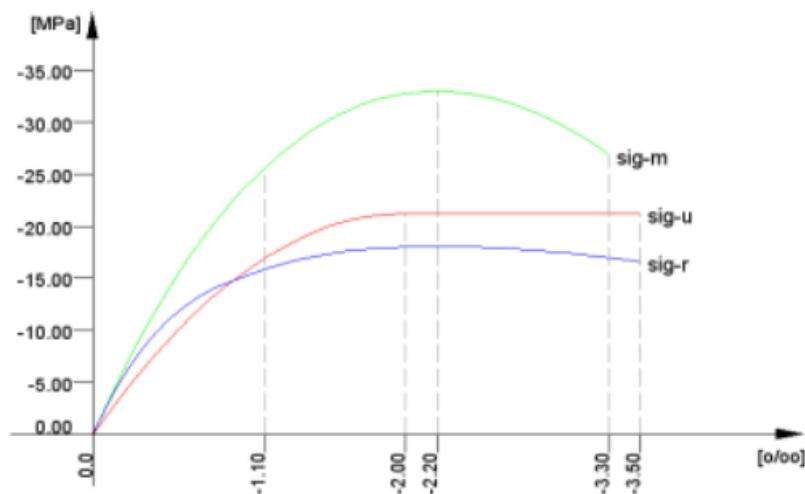

Figure 4-5: Standard stress-strain curves used in ASE. sig-m: Serviceability, sig-u: Ultimate design, sig-r: Calculatonic mean. [25]

Figure 4-6 shows which types of elements are applicable to material and/or geometrical non-linear analyses. The footnotes 1 and 2 specifies elements which requires special licences.

Element	Non-linear Material	Geometrical Non-linearity
SPRI	yes	yes
TRUS	yes+tension failure	yes
CABL	yes+compression failure	yes + cable sag
BEAM	yes	yes
PILE <sup>1</sup>	elastic bedding only	yes
QUAD <sup>2</sup>	yes	yes
BRIC <sup>1,2</sup>	yes	yes
BOUN	-	-
FLEX <sup>1,2</sup>	-	-
Halfspace <sup>2</sup>	yes	-

Figure 4-6: Overview of elements applicable for non-linear analyses. [25]

Geometrical analyses are available for both second- and third-order theory in ASE, and the essential characteristics between the theories are elaborated. Figure 4-7 displays how the second-order theory column does not deflect in z-direction, but elongates and deflects in x-direction [25]. The geometric stiffness is reduced, the beam can get longer than original, and the bottom bending moment increases due to the displacement of  $Pz$ . The third order analysis is iterated for equilibrium on the real deformed shape, as the column deforms in the physically correct path.

Figure 4-8 display a similar example of second order theory as elaborated in the Geometric non-linearity chapter. In the third order, the beam element experience a normal force that counteract a part of the applied load and the vertical deformation.

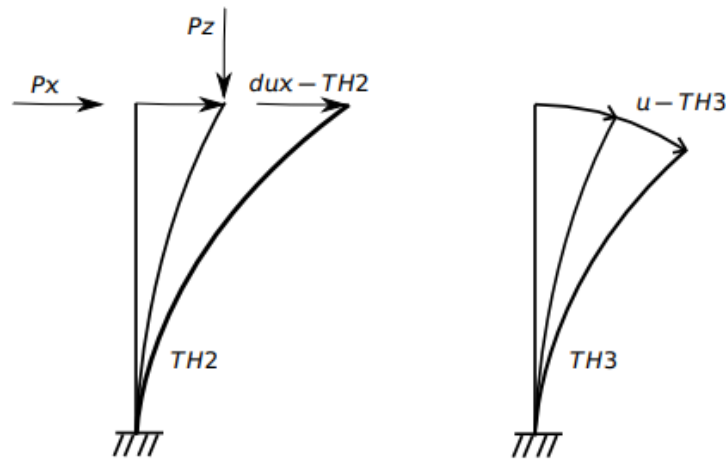

Figure 4-7: Column geometric nonlinear theory, 2nd and 3rd order. [25]

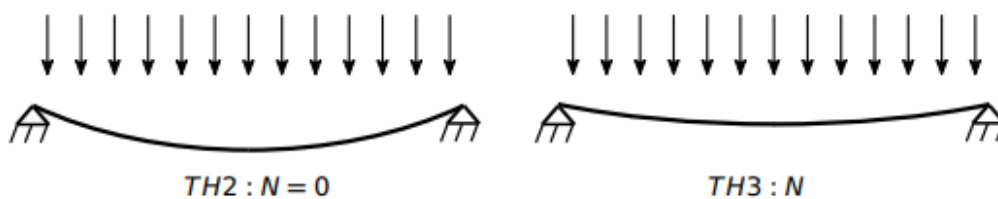

Figure 4-8: Girder using second- and third-order theories. TH3 induces a load carrying normal force N. [25]

### 4.3.3 DESI – Reinforced Concrete Design

DESI is an input record in ASE which can design reinforced concrete. By choosing limit state, material factor or not and specifying the minimum reinforcement, if not specified earlier in analysis, the record can add reinforcement that will satisfy the wanted limit. Possible load condition and codes are serviceability and ultimate loads, non-linear analysis and accidental combinations, and to only save the reinforcement specified. The record also allows for specification of maximum and optimum compression and tensile strain values, shear design and plasticity control.

DESI is often used together with the NSTR and REIN records, which controls the non-linear stress-strain state and specification for determining reinforcement respectively.

# 5. Case Study: Røydalen Bridge

## 5.1 Description

Røydalen bridge is located outside Arendal at a new distance of E18. The distance which goes in between Arendal and Tvedestrand was opened in 2019. As it is a part of a four-lane highway, the bridge distance was divided into two bridges, one for the separate directions. The one considered in this report is the northbound. The highway is classified as a H8 road according to SVV's manuals with an annual average daily traffic < 20 000, and a speed limit of 110 km/hour.

Røydalen Bridge is 170 meters long, divided in 6 spans of 25-30 meters and 7 axes, as shown in Figure 5-1. The bridge is a cast-in-situ pre-stressed beam bridge.

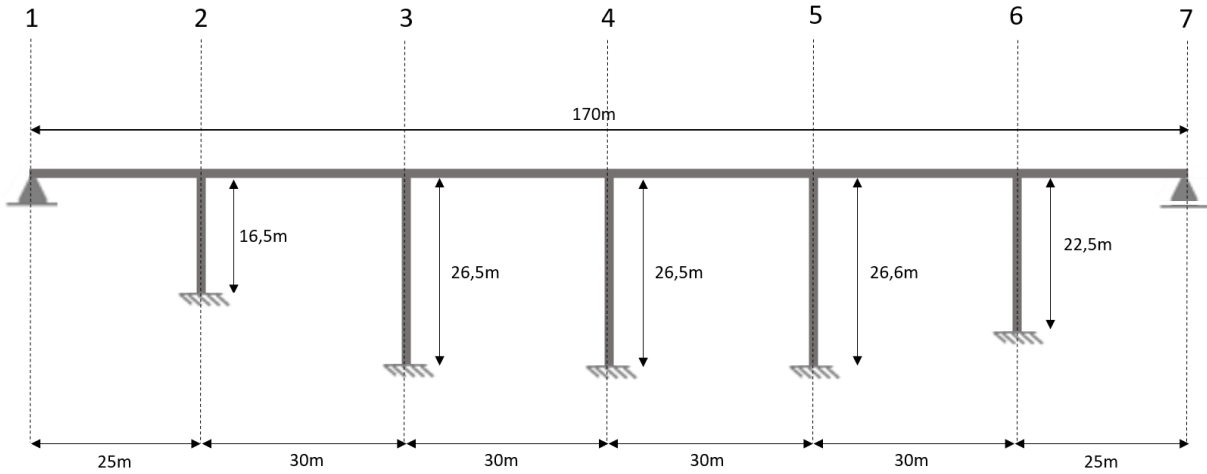

Figure 5-1: Side-view illustration of Røydalen bridge

In the ends, the deck has a pinned connection at axis 1 and a slide bearing in axis 7. The superstructure consists of the 11,5 meter wide bridge deck and the smaller functional members as guard rails and parapet walls, as shown in Figure 5-2. A 100mm layer of asphalt and damp-proof insulation are placed at the top of the bridge deck. The effective road width is 10,75 meters.

The substructure includes approach slabs, abutments, columns, end diaphragms, ballast walls and wing walls. Figure 5-3 display a section with a column, foundation and the bridge deck. The columns are monolithic connected to the bridge deck and are, from left to right in the overview, approximately 16,5 - 26,5 - 26,5 - 26,6 - 22,5 meters long. The foundations at axis 3, 4 and 5 are core drilled to solid rock and connected with steel piles. In axis 2 and 6, the foundations are bolted at solid rock.

Further documentation, including larger scale figures of the real bridge, can be found in Appendix A.

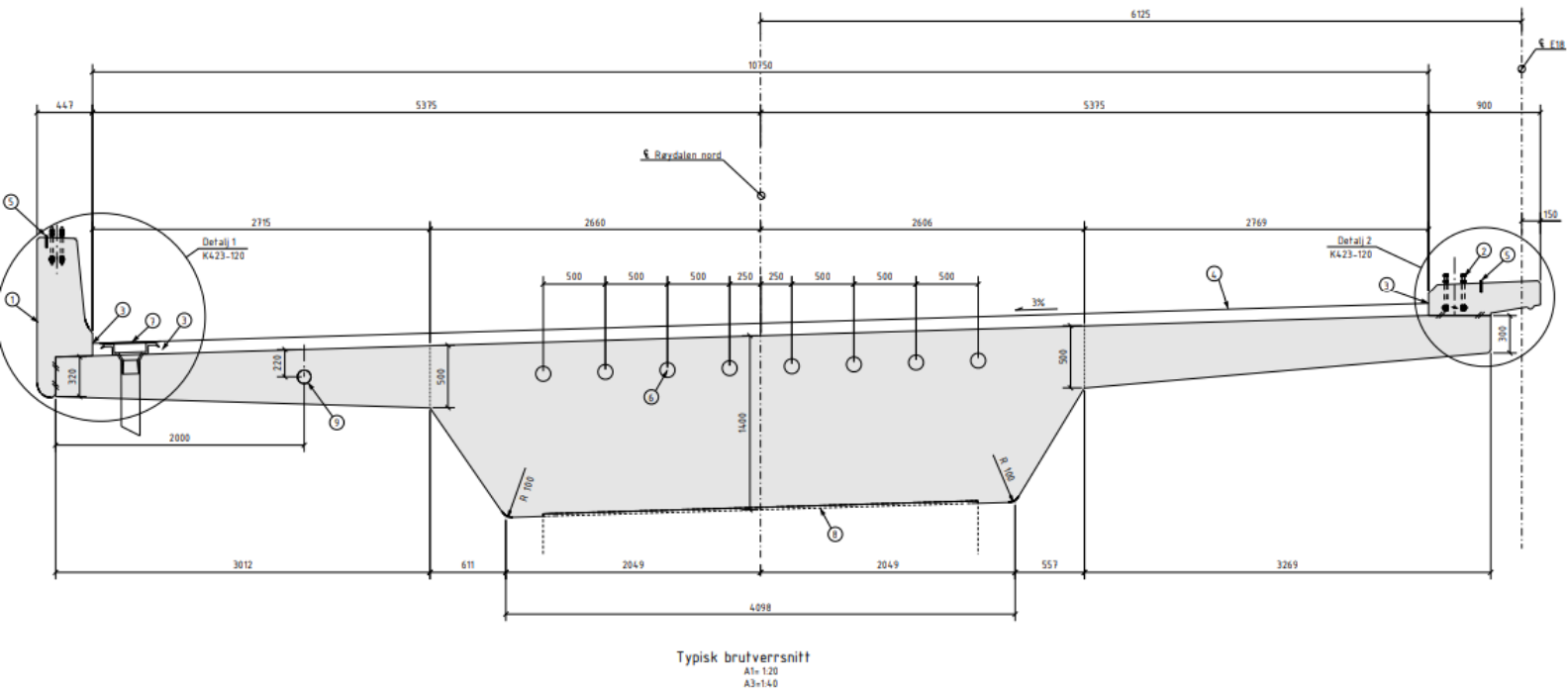

Figure 5-2: Cross-section of bridge deck, dimensions in millimetres. Larger scale figure is found in Appendix A

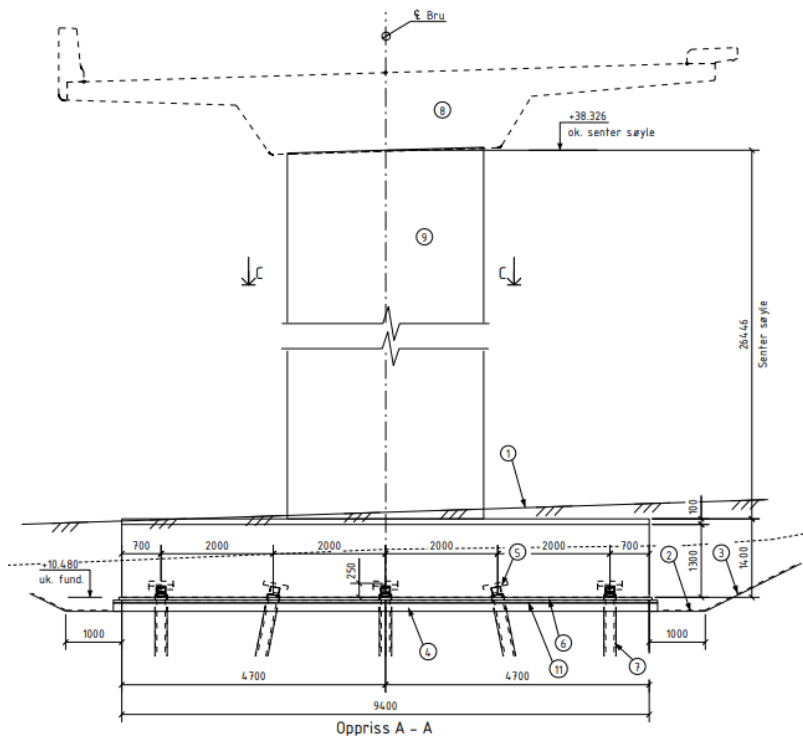

Figure 5-3: Section of Piers and foundations, dimensions in millimetres. Larger scale figure is found in Appendix A

## 5.2 Materials

### 5.2.1 Concrete

The concrete used at Røydalen Bridge are B45, with the standard mixture from SVV called SV-Standard. The properties are shown in Figure 5-4 from Sofistik. Most properties are found in table 3.1 in EC2.

**Mat 1 C 45/55 N (EN 1992)**

Young's modulus	E	36283	[N/mm <sup>2</sup> ]	Safetyfactor		1.50	[-]
Poisson's ratio	μ	0.20	[-]	Strength	f <sub>c</sub>	38.25	[MPa]
Shear modulus	G	15118	[N/mm <sup>2</sup> ]	Nominal strength	f <sub>ck</sub>	45.00	[MPa]
Compression modulus	K	20157	[N/mm <sup>2</sup> ]	Tensile strength	f <sub>ctm</sub>	3.80	[MPa]
Nominal Weight	γ	25.0	[kN/m <sup>3</sup> ]	Tensile strength	f <sub>ctk,05</sub>	2.66	[MPa]
Mean density	ρ	2400.0	[kg/m <sup>3</sup> ]	Tensile strength	f <sub>ctk,95</sub>	4.93	[MPa]
Elongation coefficient	α	1.00E-05	[1/K]	Bond strength	f <sub>bd</sub>	3.39	[MPa]
				Service strength	f <sub>cm</sub>	53.00	[MPa]
				Fatigue strength	f <sub>cd,fat</sub>	20.91	[MPa]
				Tensile strength	f <sub>ctd</sub>	1.51	[MPa]
				Tensile failure energy	G <sub>f</sub>	0.15	[N/mm]

**Figure 5-4: Concrete properties from Sofistik**

### 5.2.2 Reinforcing Steel

The steel used for reinforcement are the standard B500NC. Material properties are shown in Figure 5-5. The minimum reinforcement is set to Ø20cc250mm.

**Mat 2 B 500 B (EN 1992)**

Young's modulus	E	200000	[N/mm <sup>2</sup> ]	Safetyfactor		1.15	[-]
Poisson's ratio	μ	0.30	[-]	Yield stress	f <sub>y</sub>	500.00	[MPa]
Shear modulus	G	76923	[N/mm <sup>2</sup> ]	Compressive yield	f <sub>yc</sub>	500.00	[MPa]
Compression modulus	K	166667	[N/mm <sup>2</sup> ]	Tensile strength	f <sub>t</sub>	540.00	[MPa]
Nominal Weight	γ	78.5	[kN/m <sup>3</sup> ]	Compressive strength	f <sub>c</sub>	540.00	[MPa]
Mean density	ρ	7850.0	[kg/m <sup>3</sup> ]	Ultimate strain		50.00	[o/oo]
Elongation coefficient	α	1.20E-05	[1/K]	relative bond coeff.		1.00	[-]
max. thickness	t-max	32.00	[mm]	EN 1992 bond coeff.	k <sub>1</sub>	0.80	[-]
				Hardening modulus	E <sub>h</sub>	0.00	[MPa]
				Proportional limit	f <sub>p</sub>	500.00	[MPa]
				Dynamic allowance	σ-dyn	152.17	[MPa]

**Figure 5-5: Reinforcing steel properties from Sofistik**

### 5.2.3 Prestressing steel

For pre-stressing of Røydalen Bridge, steel with f<sub>pk</sub>=1860 and f<sub>p0,1k</sub>=1640MPa are used. Material properties are shown in Figure 5-6.

**Mat 3 Y 1860 A (EN 1992)**

Young's modulus	E	195000	[N/mm <sup>2</sup> ]	Safetyfactor		1.15	[-]
Poisson's ratio	μ	0.30	[-]	Yield stress	f <sub>y</sub>	1600.00	[MPa]
Shear modulus	G	75000	[N/mm <sup>2</sup> ]	Compressive yield	f <sub>yc</sub>	1600.00	[MPa]
Compression modulus	K	162500	[N/mm <sup>2</sup> ]	Tensile strength	f <sub>t</sub>	1860.00	[MPa]
Nominal Weight	γ	78.5	[kN/m <sup>3</sup> ]	Compressive strength	f <sub>c</sub>	1860.00	[MPa]
Mean density	ρ	7850.0	[kg/m <sup>3</sup> ]	Ultimate strain		60.00	[o/oo]
Elongation coefficient	α	1.20E-05	[1/K]	relative bond coeff.		0.50	[-]
max. thickness	t-max	18.00	[mm]	EN 1992 bond coeff.	k <sub>1</sub>	1.60	[-]
Relaxation	EN-1992	Class	2	Hardening modulus	E <sub>h</sub>	0.00	[MPa]
Relaxation	ρ(1000h)		2.50	Proportional limit	f <sub>p</sub>	1600.00	[MPa]
				Dynamic allowance	σ-dyn	160.87	[MPa]

**Figure 5-6: Pre-stressing steel properties from Sofistik**

### 5.3 Loads and load combinations

The input permanent and variable loads are revealed in this chapter. The permanent load only displays input loads in Sofistik, e.g. excluding self-weight of modelled members such as bridge deck and columns. Of the variable loads, only traffic and temperature loads are applied, to simplify the non-linear analysis.

#### 5.3.1 Permanent loads

The loads used in the different analyses are listed below. Self-weight of modelled members is calculated directly in Sofistik and not added externally. All load listed are added as either point loads [kN] or distributed loads [kN/m]. As this road is a highway, there is no pedestrian lines or similar contributing to extra loads. Soil and water pressure are neglected. Figure 5-7 shows how the additional self-weights are modelled in Sofiplus-X.

Table 5-1: Applied permanent loads

Load	Value	Load case in Sofistik
Parapet wall left	10,23kN/m	LC 2
Parapet wall right	5,45kN/m	LC 2
Railings	0,5 kN/m	LC 3
Approach slabs	399,86 kN	LC 4
End diaphragms	644 kN	LC 4
Ballast wall	373,75 kN	LC 4
Asphalt	37,5 kN/m	LC 5

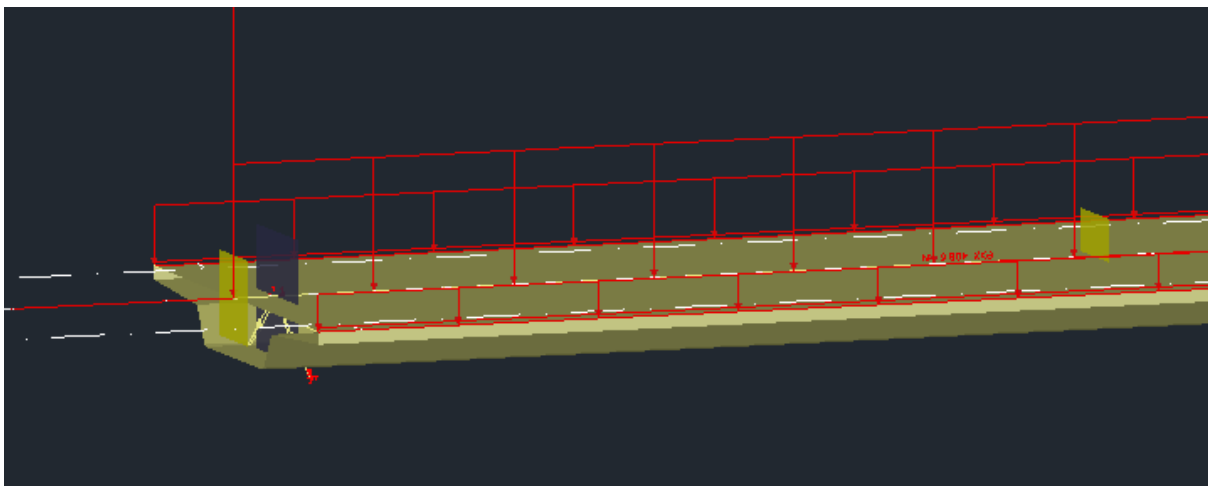

Figure 5-7: Snapshot from Sofiplus-X illustrating applied permanent loads.

In Norway, the approach slabs are standardized for structures as large as Røydalen Bridge, with a cross section as shown in Figure 5-8. The slabs are considered as simply supported beams with a free span of 0,9 times the length (L), which means 0,45L of its weight excites the bridge as half the weight is taken up by the ground. The plates are 4m long and 0,3m deep and the width is assumed to be the same as the bridge deck, 11,5meter.

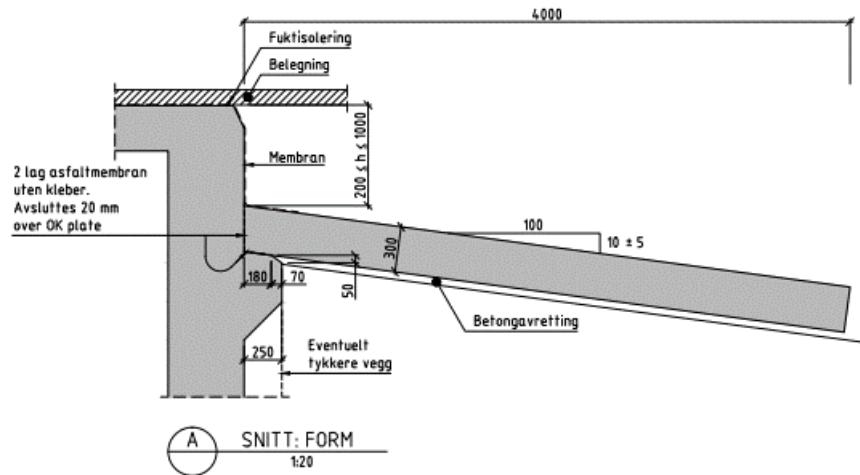

Figure 5-8: Approach slab

Over the slabs, mass is placed to reach the desired height of the road. According to NS-EN 1991 table A.6. this mass weighs 19kN/m<sup>3</sup>. The height of the masses is set to the average of 0,7 meter. Then the total excitation at the bridge from an approach slab are:

$$g_{slabs} = \left( 25 \frac{kN}{m^3} \cdot 0,3m \cdot 4m + 19 \frac{kN}{m^3} \cdot 0,7m \cdot 4m \right) \cdot 0,45 = 37,44kN/m$$

### 5.3.2 Temperature Loads

In the case of Røydalen Bridge, uniformly distributed and vertically varying temperature are considered as the other categories of thermal effects either are not relevant or small enough to be neglected. The temperature variable and load combinations are shown in Table 5-2 and Table 5-3. In Sofistik the  $\Delta$ -loads are first added one by one, before they are added together as combinations, as shown in Figure 5-9.

Table 5-2: Temperature load variables

Description		Value
Highest expected temperature	$T_{max}$	36 °C
Lowest expected temperature	$T_{min}$	-35 °C
Highest temperature at surface	$T_{e,max}$	36 - 3 = 33 °C
Lowest temperature at surface	$T_{e,min}$	-35 + 8 = -27 °C
Reference air temperature	$T_0$	10 °C
Maximum expansion	$\Delta T_{N,exp}$	33 - 10 = 23 °C
Maximum contraction	$\Delta T_{N,con}$	10 - (-27) = 37 °C
Top surface warmer than bottom	$\Delta T_{M,heat}$	-15 * 0,7 = -10,5 °C
Bottom surface warmer than top	$\Delta T_{M,cool}$	8 * 1 = 8 °C



Table 5-3: Temperature combinations

Combination		Load Case in Sofistik
T summer posdt TN+wm*dT	$23^{\circ}\text{C} - 10,5^{\circ}\text{C} \cdot 0,75$	LC 91
T summer negdt TN+wm*dT	$23 + 1 \cdot 8$	LC 92
T winter posdt TN+wm*dT	$-37^{\circ}\text{C} - 10,5^{\circ}\text{C} \cdot 0,75$	LC 93
T winter negdt TN+wm*dT	$-37^{\circ}\text{C} + 1 \cdot 8^{\circ}\text{C}$	LC 94
T summer posdt wn*TN+dT	$23^{\circ}\text{C} \cdot 0,35 - 10,5^{\circ}\text{C}$	LC 95
T summer negdt wn*TN+dT	$23^{\circ}\text{C} \cdot 0,35 + 8^{\circ}\text{C}$	LC 96
T winter posdt wn*TN+dT	$-37^{\circ}\text{C} \cdot 0,35 - 10,5^{\circ}\text{C}$	LC 97
T winter negdt wn*TN+dT	$-37^{\circ}\text{C} \cdot 0,35 + 8^{\circ}\text{C}$	LC 98

```

LC 81  TYPE T  TITL 'TN summer'
      BEAM GRP (10 60 10) TYPE DT #TNexp
      BEAM GRP 8,68      TYPE DT #TNexp
LC 82  TYPE T  TITL 'TN winter'
      BEAM GRP (10 60 10) TYPE DT #TNcon
      BEAM GRP 8,68      TYPE DT #TNcon
LC 83  TYPE T  TITL 'dT positive'
      BEAM GRP (10 60 10) TYPE DTZ #TMheat
      BEAM GRP 8,68      TYPE DTZ #TMheat
LC 84  TYPE T  TITL 'dT negative'
      BEAM GRP (10 60 10) TYPE DTZ #TMcool
      BEAM GRP 8,68      TYPE DTZ #TMcool

$ Load combinations
LC 91 Type T TITL 'T summer posdt TN+wm*dT' ; COPY 81 ; COPY 83 FACT 0.75
LC 92 Type T TITL 'T summer negdt TN+wm*dT' ; COPY 81 ; COPY 84 FACT 0.75
LC 93 Type T TITL 'T winter posdt TN+wm*dT' ; COPY 82 ; COPY 83 FACT 0.75
LC 94 Type T TITL 'T winter negdt TN+wm*dT' ; COPY 82 ; COPY 84 FACT 0.75
LC 95 Type T TITL 'T summer posdt wn*TN+dT' ; COPY 81 FACT 0.35 ; COPY 83
LC 96 Type T TITL 'T summer negdt wn*TN+dT' ; COPY 81 FACT 0.35 ; COPY 84
LC 97 Type T TITL 'T winter posdt wn*TN+dT' ; COPY 82 FACT 0.35 ; COPY 83
LC 98 Type T TITL 'T winter negdt wn*TN+dT' ; COPY 82 FACT 0.35 ; COPY 84

```

Figure 5-9: Modelling of temperature loads

### 5.3.3 Traffic loads

Traffic loads are calculated as described in chapter 3.3.4. The combination gr1a is used as it is most often the unfavourable. Which means the driveway are divided into three lanes that are excited by a uniformly distributed load and a different tandem load. As the carriageway width is 10,75 meters, the bridge is divided into three lanes of 3-meter width and 1,75-meter remaining area. In Sofistik, the UDL load is coded to be active in all traffic load cases, while the TS load are coded to act 1 meter at the time, as shown in Figure 5-10 and Figure 5-11 with LC 10015. The UDL loads are multiplied with the width of the lanes to be expressed as kN/m. As the bridge is 170 meters long, this results in 171 traffic load cases. The input values are given in Table 5-4.

Table 5-4: Applied traffic loads

	Tandem system, TS [kN] $Q_i \cdot \alpha_{Qi}$	Uniformly distributed, UDL [kNm] $q_i \cdot \alpha_{qi}$
Lane 1	300	9*0,6=5,4
Lane 2	200	2,5*1
Lane 3	100	2,5*1

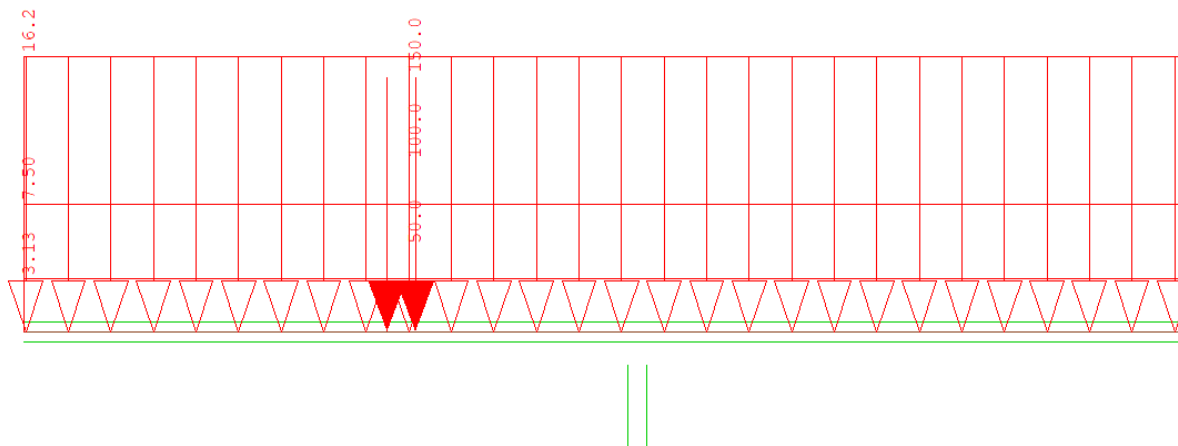

Figure 5-10: Vertical section illustrating the traffic loads

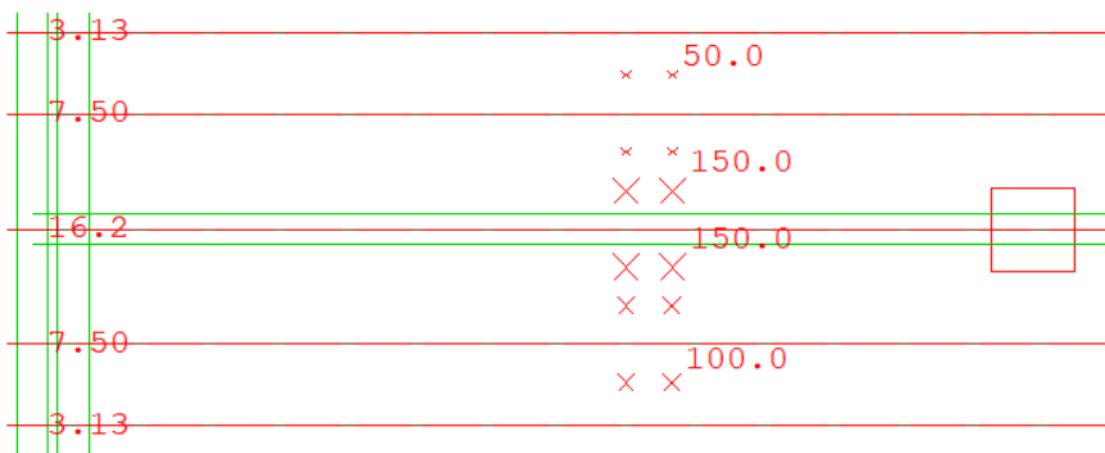

Figure 5-11: Horizontal section illustrating the traffic loads.

### 5.3.4 Linear load combinations

The linear load combinations are carried out automatically by Sofistik. By using input of favourable and unfavourable safety factors, the software automatically identifies the total most unfavourable load situation and stores the maximum and minimum if correctly coded. The combinations are coded in Teddy files and asks specific for the combination of maximum and minimum bending moments, shear stresses and normal force.

Table 5-5 shows the safety factors applied in linear load combinations.

**Table 5-5: Applied safety factors to load combinations, favourable/unfavourable**

Combination	Safety factor, $\gamma_g$ Permanent load $G_k$	Safety factor, $\gamma_p$ Pre-stressing	Safety factor, $\gamma_{Q1}$ Dominating Temperature loads, $Q_{1k}$	Safety factor, $\gamma_{Qi}$ Temperature loads, $Q_{ik}$	Safety factor, $\gamma_{Q1}$ Dominating Traffic loads, $Q_{1k}$	Safety factor, $\gamma_{Qi}$ Traffic loads, $Q_{ik}$
SLS Frequent	1,0	1,0	0,6	0/0,5	0,7	0,2/0,5
ULS 6.10a	1,0/1,35	0,9/1,1	$0,7 \cdot 1,2 = 0,84$	0,84	$0/1,35 \cdot 0,7 = 0,945$	0,945
ULS 6.10b	1,0/1,2	0,9/1,1	1,2	0,84	0/1,35	0,945

In the case of Røydalen bridge, the load scenario is considered to have frequent load combinations in the check for serviceability. In that case, a crack width control is required, with a maximum crack width of 0,39mm.

### 5.3.5 Non-linear load combinations

The non-linear analysis is carried out with each of the 171 traffic load cases combined with the 8 different temperature load scenarios. In addition to the 8 temperature combinations, a load case with no temperature effects are added. This result in a total of 1539 possible load combinations as shown in equation below. The same safety factors as in the linear analysis are used.

$$171 \text{ traffic cases} \times 9 \text{ temperature cases} = 1539 \text{ load combinations}$$

Geometrical non-linearity is accounted for by calculating the system using third order theory. Material non-linearity is also specified in the Teddy task. Sofistik accounts for creep and shrinkage using construction stages, where the bridge is “built” digitally in the correct order. The geometrical non-linear input is first added here. In a later Teddy-task, the non-linear analysis is constructed. First, the system is calculated linearly with the self-weights and pre-stressing. Then the last construction step from construction stages are used as a primary load case, and the whole system calculated with third order behaviour. This analysis is further used as a basis for the full non-linear analysis as a primary load case, or effectively a predefined deformed structure. In the full non-linear analysis, only the columns are specified non-linear, as the rest of the structure already is deformed for the internal loads. Now, the additional variable loads are added, together with safety factors for all loads. Figure 5-12 and Figure 5-13 shows this process for a single non-linear load combination. The load case LC 102 is used as primary load case in all non-linear load combinations.

```

+prog ASE urs:68.2
Head dl=4032
echo grp,load no
SYST prob th3 plc 4032 $ Geometric non-linearity with LC4032 as PLC
GRP 'CSM' CS 32 $ Running the system non-linear
LC 102 facd 1.0 titl 'th3 1.00 times dl=4032'
lcc 2 FACT 1.00 PLC YES $ already applied in PLC g_2
LCC 3 FACT 1.00 PLC YES $ already applied in PLC g_2
LCC 4 FACT 1.00 PLC YES $ already applied in PLC g_2
LCC 5 FACT 1.00 PLC YES $ already applied in PLC g_2
LCC 50 PLC YES $ already applied in PLC prestress
end

```

Figure 5-12: Implementation of creep and shrinkage using PLC from CSM

```

+prog ASE urs:68.8
Head Non-linear analysis
ECHO MAT YES $ -> See ASE-output: Maximum possible concrete stress
ECHO GRP,LOAD NO
CTRL ITER 3 V2 1 $ Improves iterations
REIN LCR 105 $ Stores the reinforcement in a design case
SYST PROB TH3 PLC 102 TOL -10.0 FMAX 2.0 iter - $ Geometric non-linearity
DESI ULTI KSV ULD KSB ULD $ Iterates until ultimate limits are reached
NSTR kmod K1 KSV SLD KSB SLD fmax 0.8 $ material non-linearity
GRP 'CSM' LINE CS 32 $ Including the stresses from CSM linearly
GRP 5 FULL CS 32 t1 0 $ Running columns non-linear
LC 105 facd 1.2 titl 'Nonlin test' $ FACD activates g_1
lcc 2 FACT 1.2 PLC YES $ already applied in PLC g_2
LCC 3 FACT 1.2 PLC YES $ already applied in PLC g_2
LCC 4 FACT 1.2 PLC YES $ already applied in PLC g_2
LCC 5 FACT 1.2 PLC YES $ already applied in PLC g_2
LCC 50 FACT 1.1 PLC YES $ already applied in PLC Prestressing
LCC 10152 fact 1.35 $ gr1a
LCC 94 fact 1.2 $ Temp
end

```

Figure 5-13: Set up of a single non-linear load combination

To perform a full non-linear analysis, every 1539 load combination are coded one by one, similar as in Figure 5-13. To accelerate the process of writing the load cases, the coding software Visual Studio was employed. Through the software, a Teddy-task with 32 337 written lines was constructed for each non-linear analysis, resulting in 97 011 written lines in total to be used in the non-linear analyses. The Visual Studio code can be found in appendix C.

### 5.4 Analytical model

The analytical model used in the analyses is showed in Figure 5-14. The modelled support mechanisms are notable in the figure, where the columns are fixed and the ends are supported by springs in x-,y- and z- direction at left (effectively pinned), and spring in y- and z- direction at right end (effectively roller). As beam theory is the established method for bridge design, beam elements are used. The elements are restricted to be maximum 1 meter long, to form a satisfactory mesh.

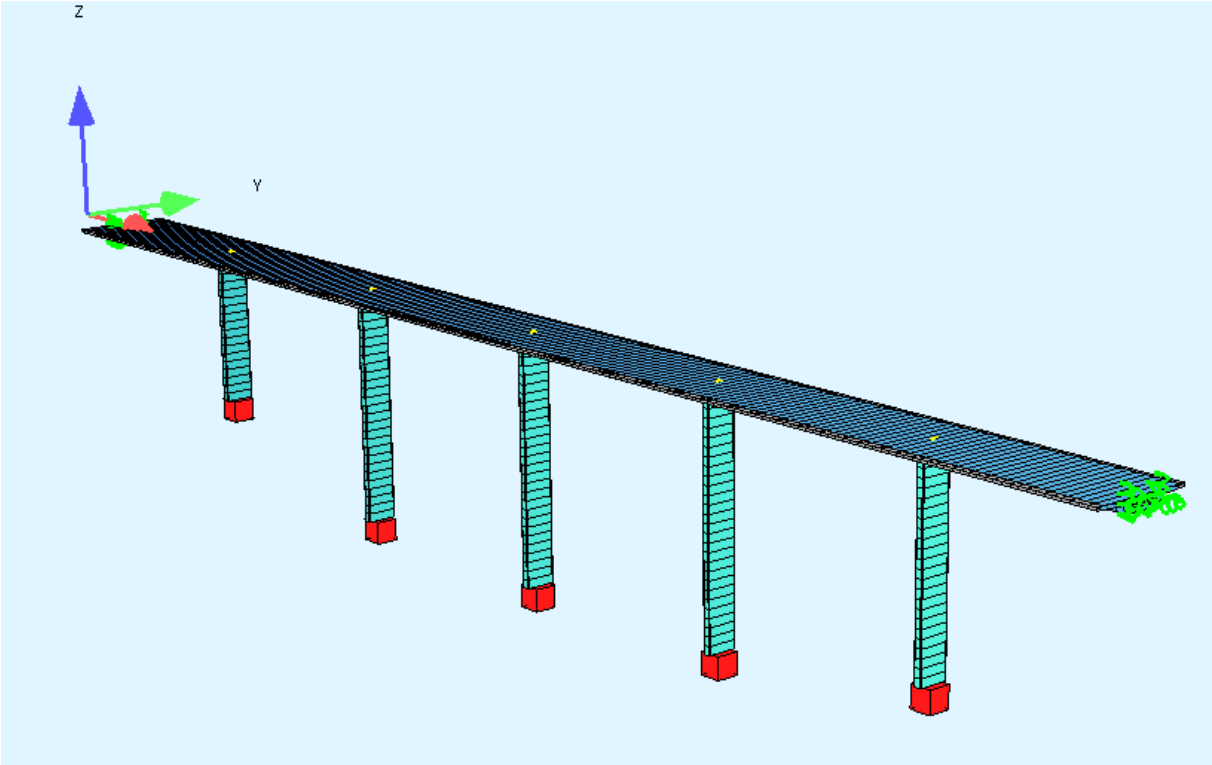

Figure 5-14: Analytical model, screenshot from SSD

### 5.4.1 Cross-sections and geometric constants

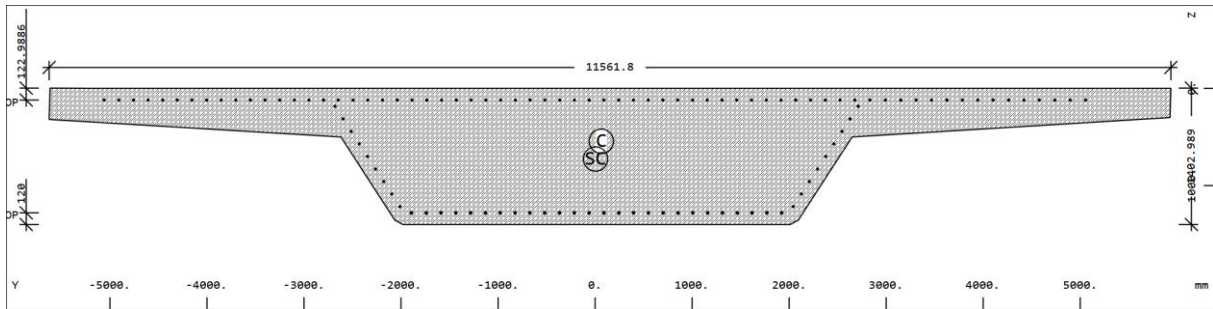

Figure 5-15: Cross-section of bridge deck from Sofistik, dimensions given in millimetres

#### Static properties of cross section

Mat	A[m <sup>2</sup> ]	Ay[m <sup>2</sup> ]	Iy[m <sup>4</sup> ]	yc[mm]	ysc[mm]	E[N/mm <sup>2</sup> ]	g[kg/m]	I-1[m <sup>4</sup> ]
MRf	It[m <sup>4</sup> ]	Az[m <sup>2</sup> ]	Iz[m <sup>4</sup> ]	zc[mm]	zsc[mm]	G[N/mm <sup>2</sup> ]		I-2[m <sup>4</sup> ]
		Ayz[m <sup>2</sup> ]	Iyz[m <sup>4</sup> ]					α[°]
1	9.3936E+00	8.340E+00	1.526E+00	64.2	4.3	36283	23484.0	5.841E+01
2 <sup>1</sup>	3.833E+00	1.735E+00	5.841E+01	543.7	726.3	15118	(BEAM)	1.525E+00
			-1.850E-01					89.81

<sup>1</sup> Reinforcements are not considered in the sectional values

Mat	material number	yc[mm],zc[mm]	ordinate of elastic centroid
A[m <sup>2</sup> ]	sectional area	ysc[mm],zsc[mm]	ordinate of shear centre
Ay[m <sup>2</sup> ],Az[m <sup>2</sup> ],Ayz[m <sup>2</sup> ]	transverse shear deformation area	E[N/mm <sup>2</sup> ]	Young's modulus
Iy[m <sup>4</sup> ],Iz[m <sup>4</sup> ],Iyz[m <sup>4</sup> ]	bending moment of inertia	g[kg/m]	weight per length
I-1[m <sup>4</sup> ],I-2[m <sup>4</sup> ],α[°]	principal moments of inertia and angle of the principal axes		
MRf	reinforcement material number		
It[m <sup>4</sup> ]	torsional moment of inertia		
G[N/mm <sup>2</sup> ]	Shear modulus		

Figure 5-16: Static properties of bridge deck cross-section

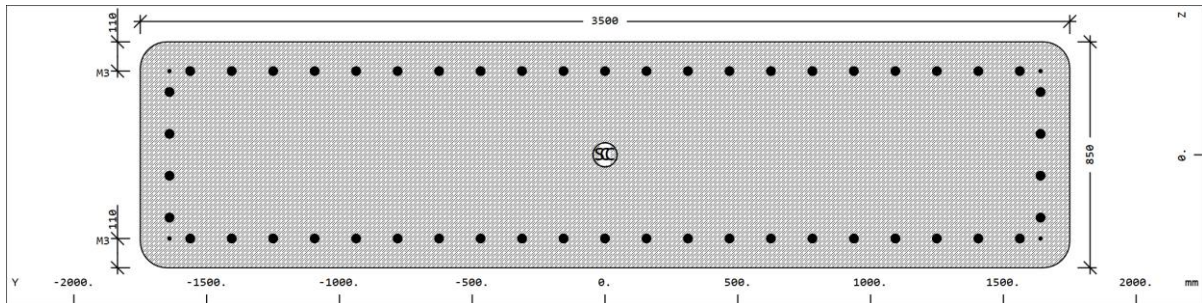

Figure 5-17: Cross-section of column from Sofistik, dimensions given in millimetres

#### Static properties of cross section

Mat	A[m <sup>2</sup> ]	Ay[m <sup>2</sup> ]	Iy[m <sup>4</sup> ]	yc[mm]	ysc[mm]	E[N/mm <sup>2</sup> ]	g[kg/m]	I-1[m <sup>4</sup> ]
MRf	It[m <sup>4</sup> ]	Az[m <sup>2</sup> ]	Iz[m <sup>4</sup> ]	zc[mm]	zsc[mm]	G[N/mm <sup>2</sup> ]		I-2[m <sup>4</sup> ]
		Ayz[m <sup>2</sup> ]	Iyz[m <sup>4</sup> ]					α[°]
5	2.9662E+00	2.474E+00	1.777E-01	0.0	0.2	36283	7415.6	3.011E+00
2 <sup>1</sup>	6.097E-01	2.496E+00	3.011E+00	0.0	0.0	15118	(BEAM)	1.777E-01
			-1.487E-06					90.00

<sup>1</sup> Reinforcements are not considered in the sectional values

Mat	material number	yc[mm],zc[mm]	ordinate of elastic centroid
A[m <sup>2</sup> ]	sectional area	ysc[mm],zsc[mm]	ordinate of shear centre
Ay[m <sup>2</sup> ],Az[m <sup>2</sup> ],Ayz[m <sup>2</sup> ]	transverse shear deformation area	E[N/mm <sup>2</sup> ]	Young's modulus
Iy[m <sup>4</sup> ],Iz[m <sup>4</sup> ],Iyz[m <sup>4</sup> ]	bending moment of inertia	g[kg/m]	weight per length
I-1[m <sup>4</sup> ],I-2[m <sup>4</sup> ],α[°]	principal moments of inertia and angle of the principal axes		
MRf	reinforcement material number		
It[m <sup>4</sup> ]	torsional moment of inertia		
G[N/mm <sup>2</sup> ]	Shear modulus		

Figure 5-18: Static properties of column cross-section

### 5.4.2 Verification of analytical model

When using FEM software, a validation of results by hand calculations is recommended to secure reliable results. This chapter displays the difference between hand calculations and Sofistik values of cross-section parameters and a validation of the static indeterminate bridge model. The validation of the static system is performed with the Hardy-Cross method, which is based on linear elastic beam theory and comparable to the FEM analysis as beam elements are used. Hardy-Cross conducts stiffnesses coefficients and rearranging of loads in the monolithic points at the structure. For simplicity, the model is validated when excited for self-weight only. Complete calculations can be found in appendix B.

**Table 5-6: Verification of geometric properties**

Cross-section parameters	$A_{\text{bridge deck}}$ [m <sup>2</sup> ]	$A_{\text{column}}$ [m <sup>2</sup> ]	$G_{\text{bridge}}$ [kN/m]	$Z_c$ [m]	$I_{y, \text{bridge}}$ [m <sup>4</sup> ]	$I_{y, \text{column}}$ [m <sup>4</sup> ]
Sofistik	9,39	2,9662	234,84	0,8563	1,526	0,177
Hand calculations	9,39	2,975	234,75	0,8561	1,544	0,1791
Difference	0%	0,3%	0,04%	0,02%	1,1%	1,1%

The difference in geometric properties are minimal and expected due to minor simplifications in hand calculations. The values verify the analytical model for further calculations.

Table 5-7 shows the comparison of hand calculations and Sofistik. The difference is satisfactory small, which means the model is approved for full analyses.

**Table 5-7: Comparison of hand calculations and Sofistik-values of bending moments**

Section	Hand calculations	Sofistik	Difference
$M_{AB}$	10 216,93	10 437,00	2,1 %
$M_B$	- 17 570,33	- 17 818,00	1,4 %
$M_{BC}$	8 839,04	8 779,00	-0,7 %
$M_c$	- 17 606,25	- 17 512,00	-0,5 %
$M_{CD}$	8 803,13	8 836,00	0,4 %
$M_D$	- 17 606,25	- 17 634,00	0,2 %
$M_{DE}$	8 803,13	8 820,00	0,2 %
$M_E$	- 17 606,25	- 17 535,00	-0,4 %
$M_{EF}$	8 803,13	8 781,00	-0,3 %
$M_F$	- 18 511,55	- 17 717,00	-4,5 %
$M_{FG}$	10 251,87	10 557,00	2,9 %

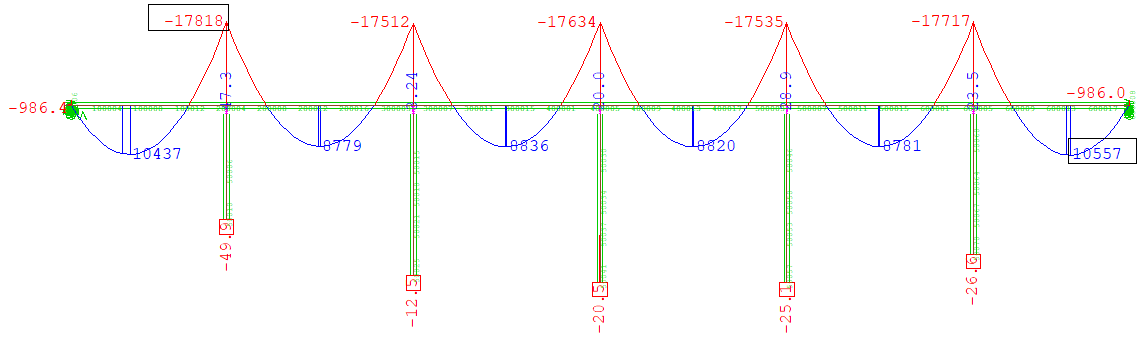

Figure 5-19: Bending moment diagram [kNm] for self-weight g1



## 6. Results of the Analysis

---

The aim of the thesis was to compare linear and non-linear behaviour of a pre-stressed concrete bridge. This chapter reveals the results of the different analyses. Firstly, the results from the linear analysis are carried out, with its resulting forces and design values from the different limit states combination. Secondly, the results from non-linear analysis are carried out similarly. In the end a comparison chapter of the most relevant output is added.

All information is presented with graphics from the program modules “Graphics” or “Result Viewer” before they are summarized in tables. The presented results include maximum bending moment, axial force, capacity, required reinforcement and stresses in the materials.

In design of the columns, minimum reinforcement is set to Ø20cc250, or more comparable to results, 12,57 cm<sup>2</sup>/m. The input record DESI in ASE overrules the minimum reinforcement and stores the required amount reinforcement. In addition, Sofistik increases the minimum reinforcement to the minimum required in the respective cross-section with the formulae  $A_{sl,min} = 0,5 \cdot \frac{N_{ed}}{f_{yd}}$ . To present tangible results, the amount reinforcement is presented both in cm<sup>2</sup>/m and kg steel. The accumulated reinforcement in each check is included.

The non-linear analyses produced enormous amount of output. A report from one load case can be found in appendix D.

## 6.1 Linear Analysis

The linear analyses are displayed with the load combination giving maximum bending moment, and the relevant material parameters connected to the forces. Required reinforcement is also shown. Every analysis is fully utilized in column 5, in regards of bending moment and axial force. Both the concrete and reinforcement stresses are at its limit or too high in the ultimate limit states and just adequate in the service limit state.

### 6.1.1 Service limit state

BEAM	x [m]	LC	Designation	factor [-]	MY [kNm]
50120	0.978	5006	Creep due to hardening	1.000	-0.00
		5030	Infinity creep	1.000	1246.21
		5031	Infinity creep	1.000	380.24
		5032	Infinity creep	1.000	49.30
		5005	Installation of columns	1.000	0.00
		5010	overbyg	1.000	-22.80
		5020	Asphalt	1.000	-0.39
		10156	load group gr1a	0.500	260.63
		5015	Prestressing 50% of fas	1.000	1125.11
		94	T winter negdt TN+wm*dT	0.600	3926.72
50120	0.978	1209	MAXF-MY		5264.02

Figure 6-1: SLS load combination returning highest My

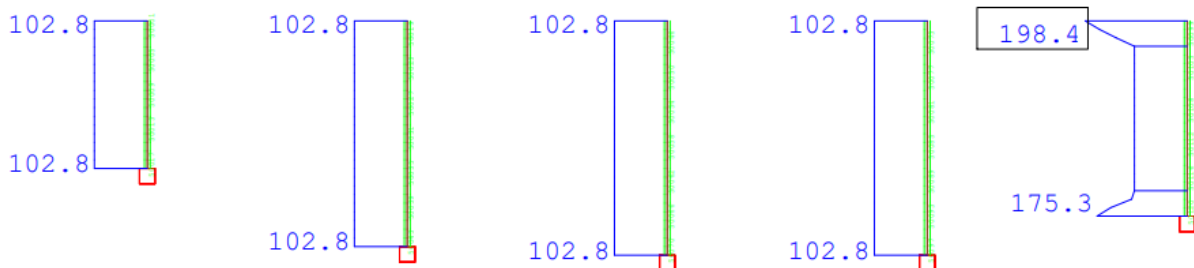

Figure 6-2: Required longitudinal reinforcement [cm<sup>2</sup>/m], linear SLS

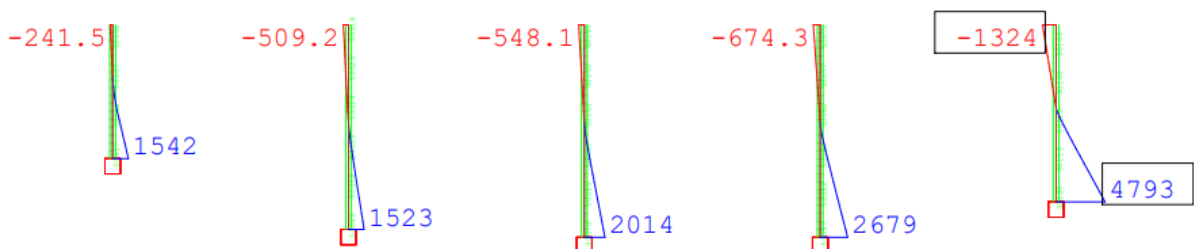

Figure 6-3: Resulting max bending moment My [kNm], linear SLS

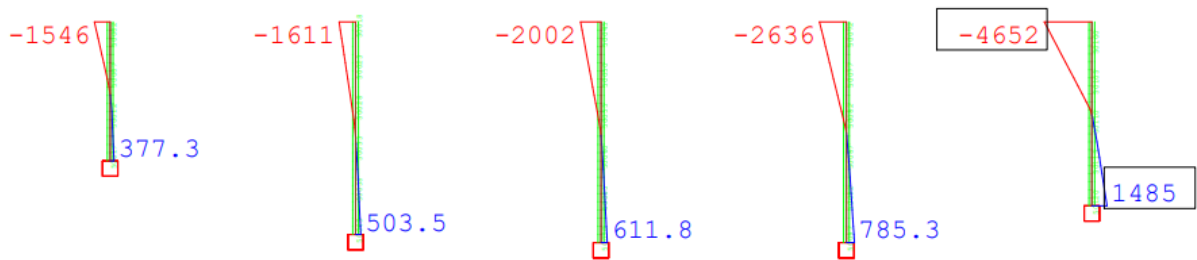

Figure 6-4: Resulting minimum bending moment  $M_y$  [kNm], linear SLS

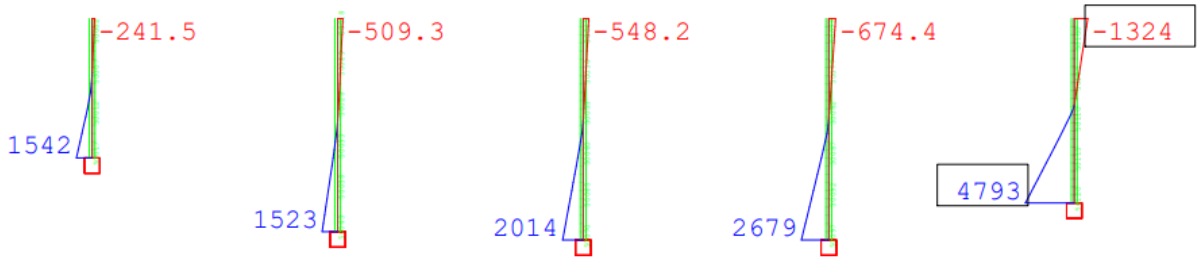

Figure 6-5: Design capacity max  $M_y$  [kNm], linear SLS

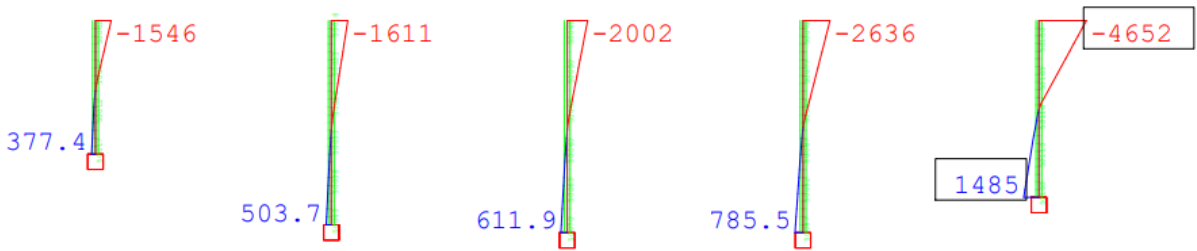

Figure 6-6: Design capacity min  $M_y$  [kNm], linear SLS

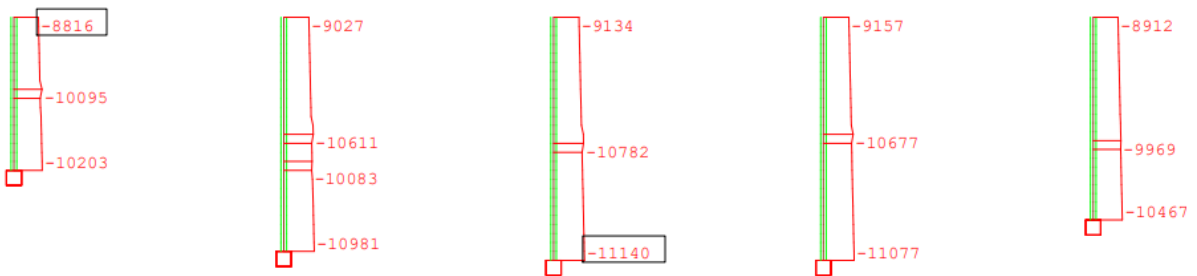

Figure 6-7: Max axial force  $N$  [kN], linear SLS

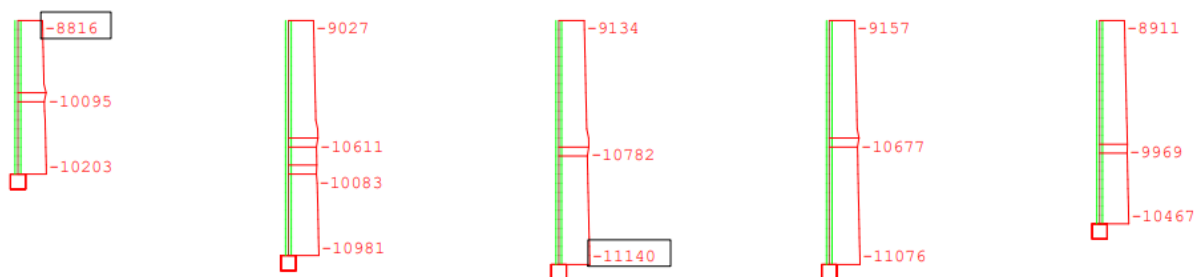

Figure 6-8: Design axial capacity  $N$  [kN], linear SLS

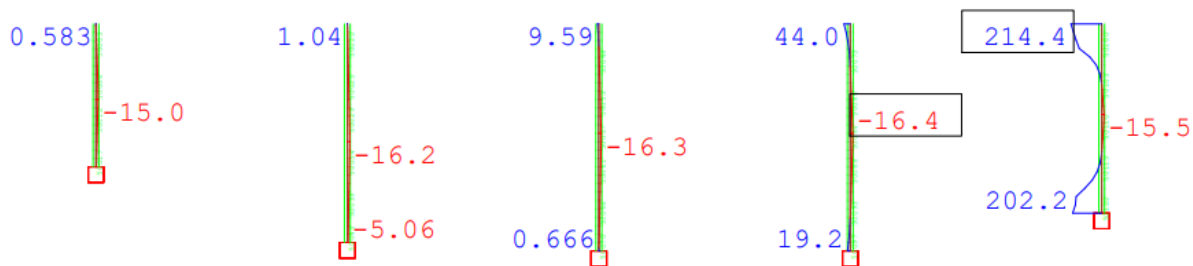

Figure 6-9: Maximum stress in reinforcement [MPa], linear SLS

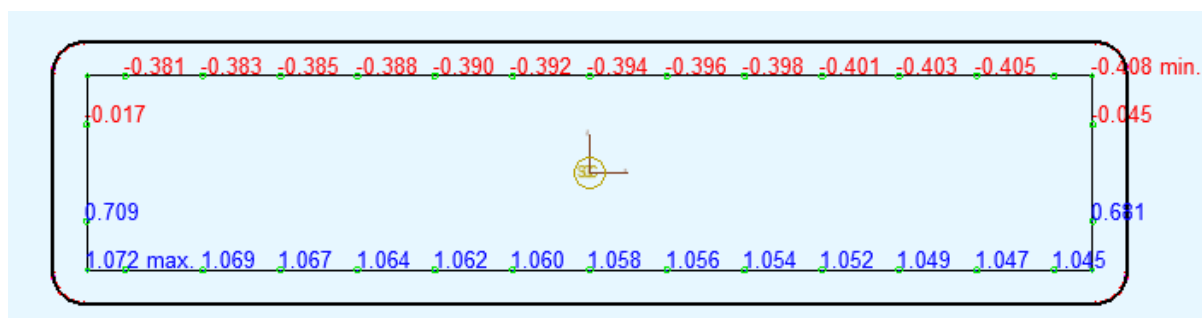

Figure 6-10: Maximum strain in cross-section at top of column five, element nr. 50098

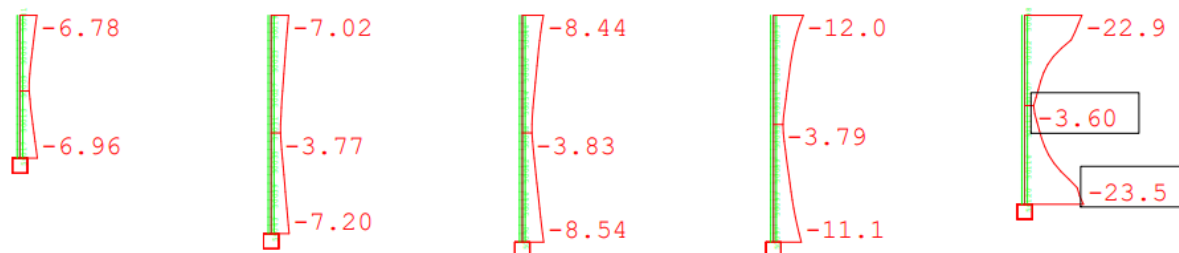

Figure 6-11: Maximum compressive stress in concrete [MPa], linear SLS

### 6.1.2 Ultimate limit state 6.10a

BEAM	x [m]	LC	Designation	factor [-]	MY [kNm]
50120	0.978	5006	Creep due to hardening	1.350	-0.00
		5030	Infinity creep	1.350	1246.21
		5031	Infinity creep	1.350	380.24
		5032	Infinity creep	1.350	49.30
		5005	Installation of columns	1.000	0.00
		5010	overbyg	1.000	-22.80
		5020	Asphalt	1.000	-0.39
		10156	load group gr1a	0.945	260.63
		5015	Prestressing 50% of fas	1.100	1125.11
		94	T winter negdt TN+wm*dT	0.840	3926.72
50120	0.978	2209	MAX-MY		7021.44

Figure 6-12: ULS a load combination returning highest My

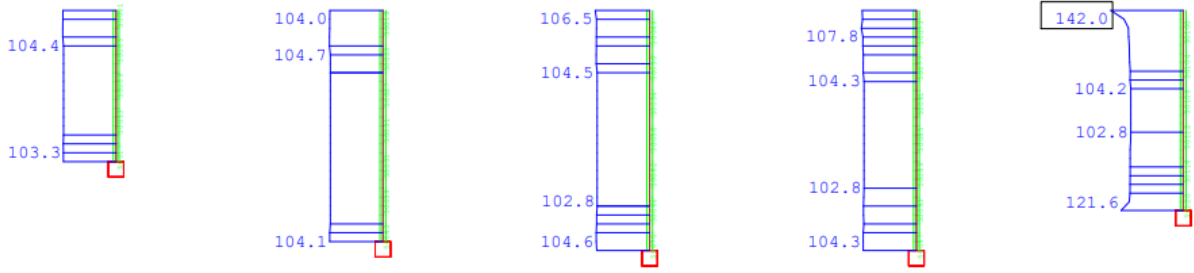

Figure 6-13: Required longitudinal reinforcement[cm<sup>2</sup>/m], linear ULS a

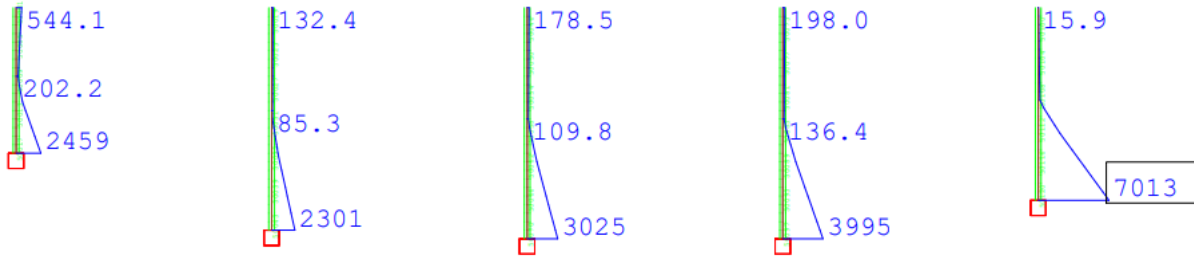

Figure 6-14: Maximum bending moment My [kNm], linear ULS a

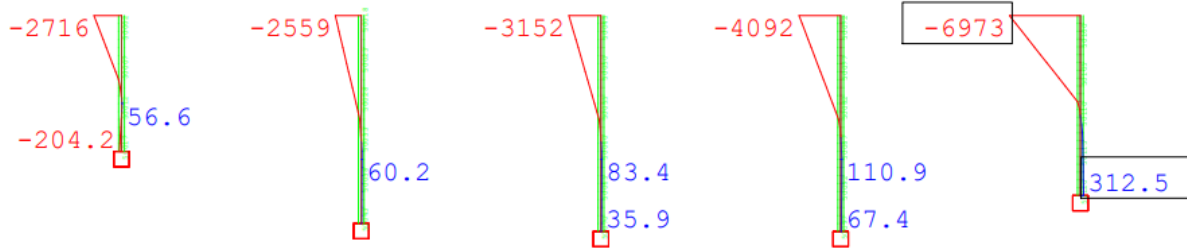

Figure 6-15: Minimum bending moment My [kNm], linear ULS a

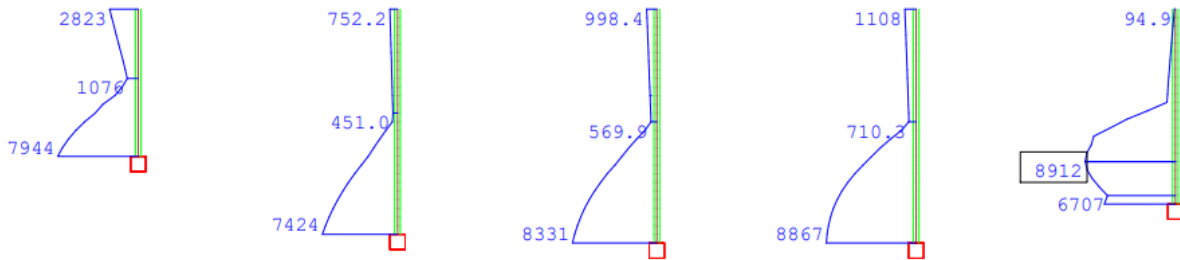

Figure 6-16: Design capacity max My [kNm], linear ULS a

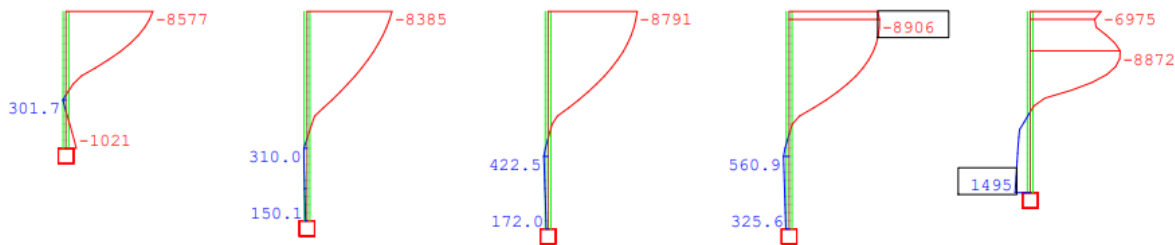

Figure 6-17: Design capacity min My [kNm], linear ULS a

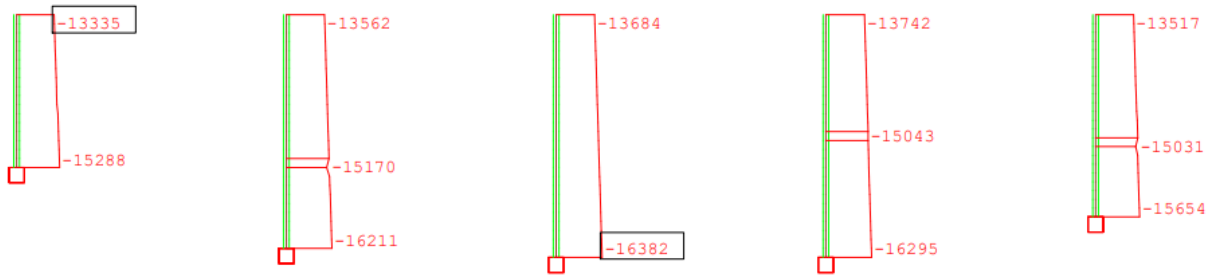

Figure 6-18: Max normal force N [kN], linear ULS a

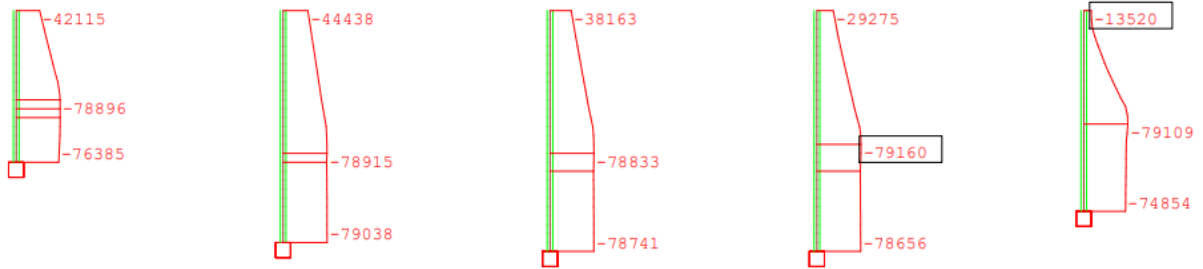

Figure 6-19: Design capacity N [kN] from design case giving min my, linear ULS a

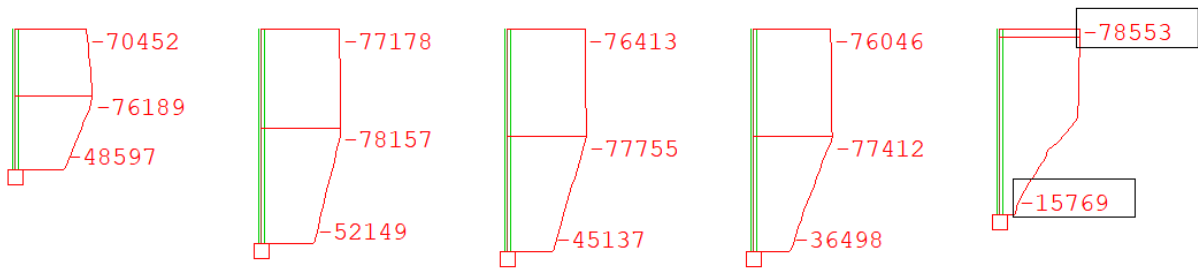

Figure 6-20: Design capacity N [kN] from design case giving max my, linear ULS a

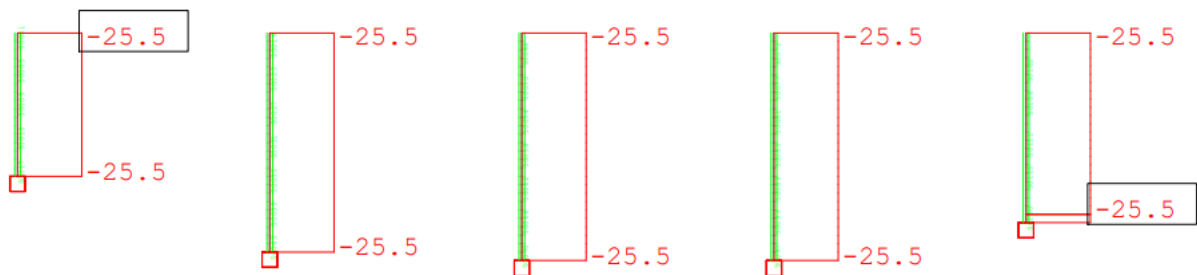

Figure 6-21: Maximum compression stress in concrete [MPa], linear ULS a

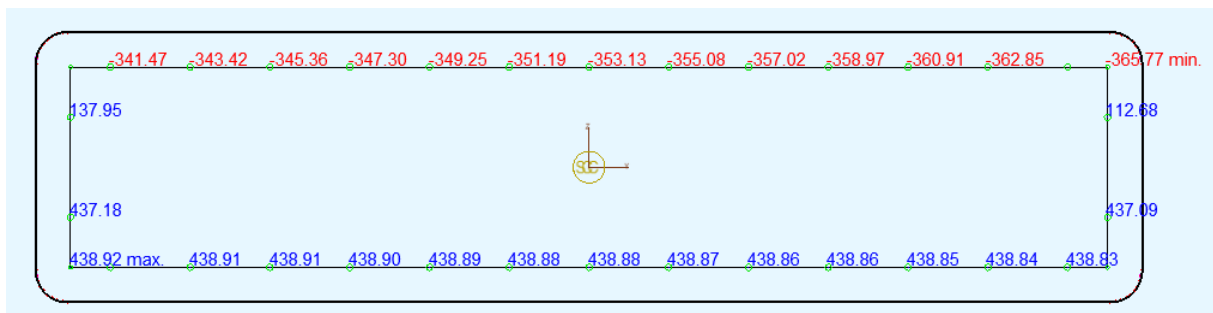

Figure 6-22: Maximum stress in cross-section 50098, at top of column 5, linear ULS a

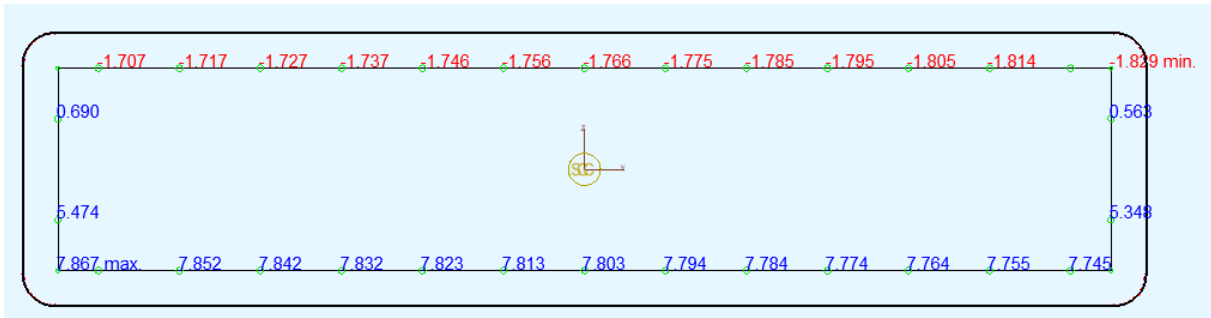

Figure 6-23: Maximum strain in cross-section 50098, at top of column 5, linear ULS a

### 6.1.3 Ultimate limit state 6.10b

BEAM	x [m]	LC	Designation	factor [-]	MY [kNm]
50120	0.978	5006	Creep due to hardening	1.350	-0.00
		5030	Infinity creep	1.350	1246.21
		5031	Infinity creep	1.350	380.24
		5032	Infinity creep	1.350	49.30
		5005	Installation of columns	1.000	0.00
		5010	overbyg	1.000	-22.80
		5020	Asphalt	1.000	-0.39
		10156	load group gr1a	0.945	260.63
		5015	Prestressing 50% of fas	1.100	1125.11
		94	T winter negdt TN+wm*dT	1.200	3926.72
50120	0.978	2309	MAX-MY		8435.05

Figure 6-24: ULS b load combination returning highest My

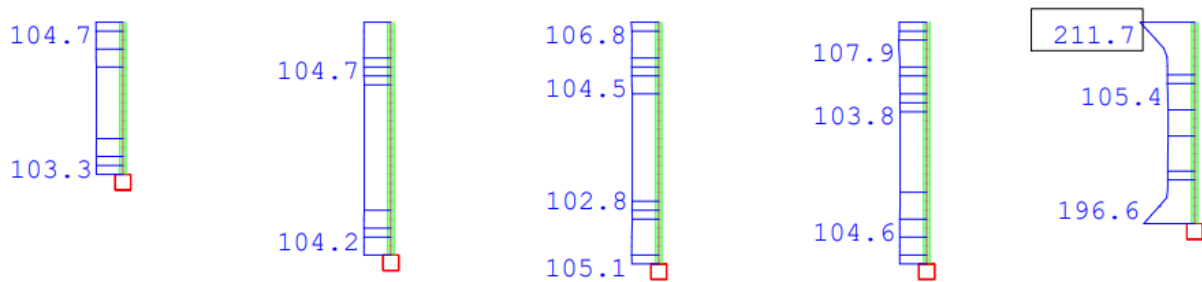

Figure 6-25: Required longitudinal reinforcement [cm<sup>2</sup>/m], linear ULS b

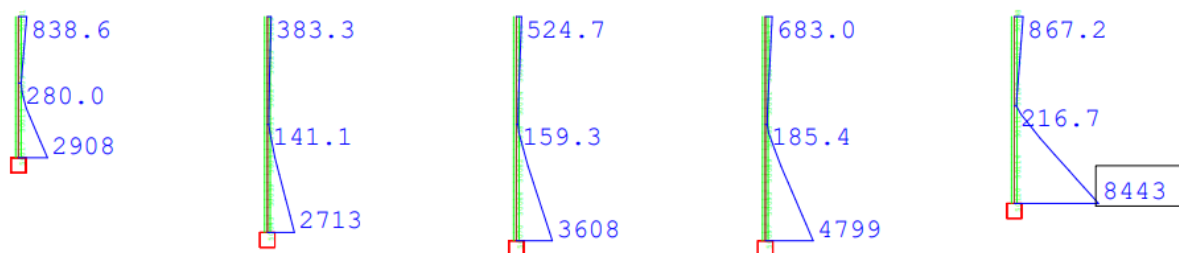

Figure 6-26: Maximum bending moment My [kNm], linear ULS b

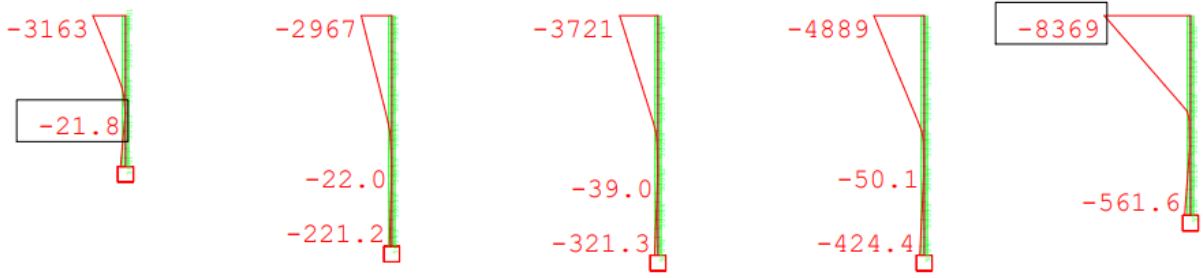

Figure 6-27: Minimum bending moment  $M_y$  [kNm], linear ULS b

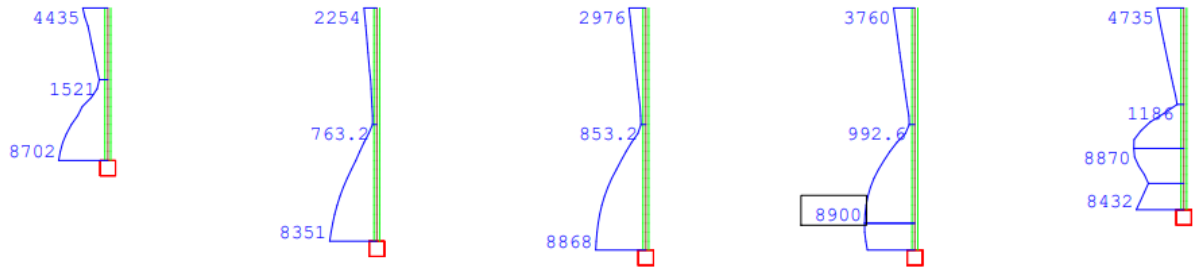

Figure 6-28: Design capacity max  $M_y$  [kNm], linear ULS b

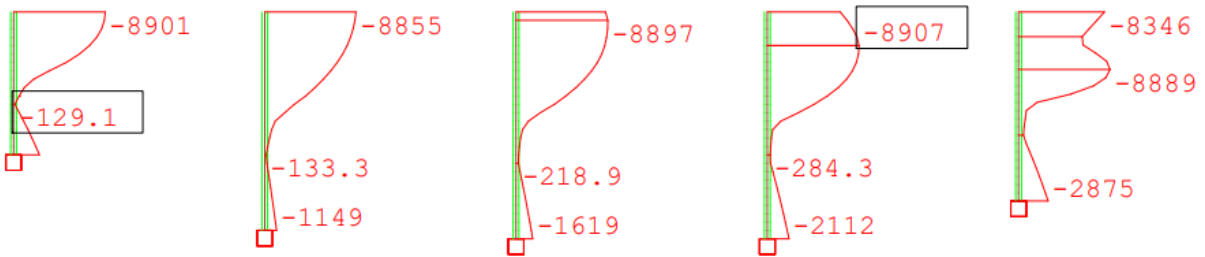

Figure 6-29: Design capacity min  $M_y$  [kNm], linear ULS b

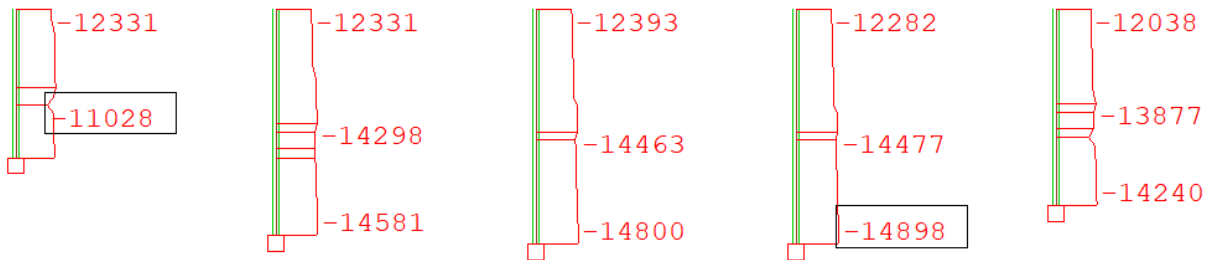

Figure 6-30: Max axial force  $N$  [kN], linear ULS b

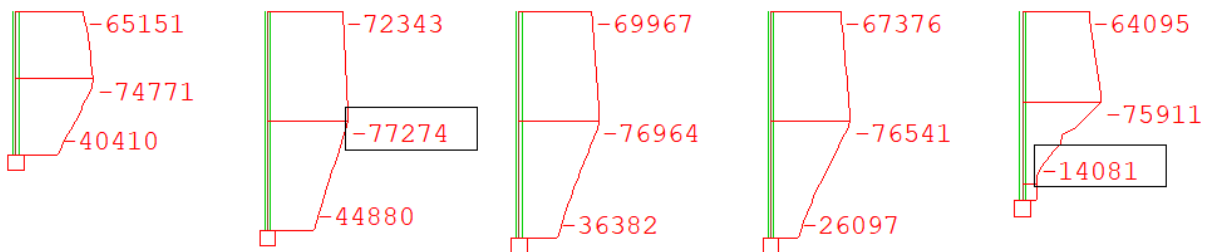

Figure 6-31 Design capacity  $N$  [kN] from design case giving max  $M_y$ , linear ULS b



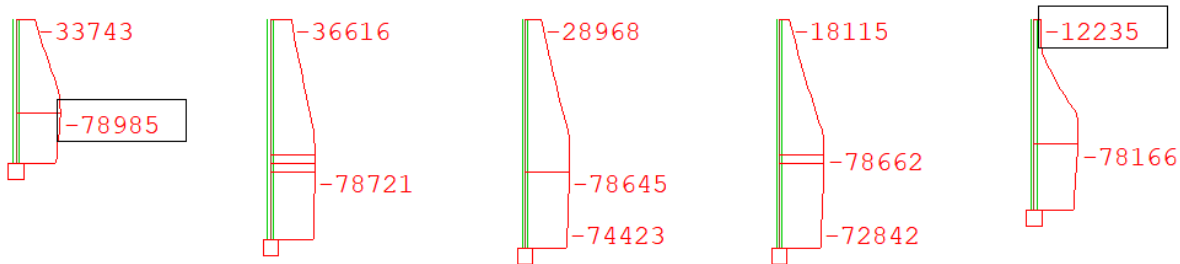

Figure 6-32: Design capacity N [kN] from design case giving min  $m_y$ , linear ULS b

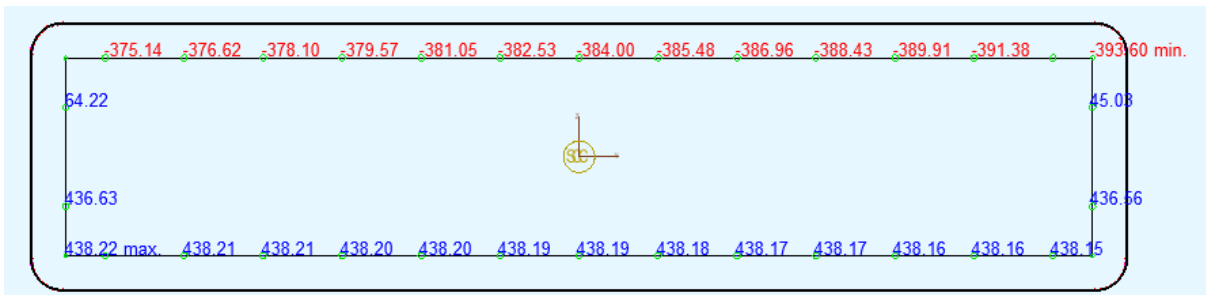

Figure 6-33: Maximum stress in cross-section 50098, at top of column 5, linear ULS b

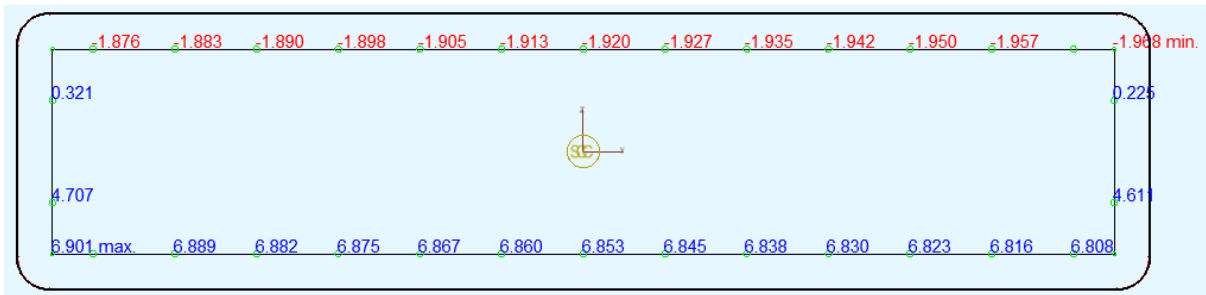

Figure 6-34: Maximum strain in cross-section 50098, at top of column 5, linear ULS b

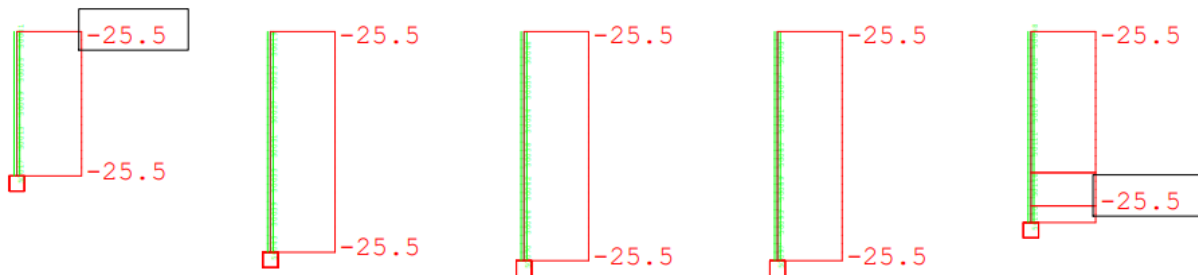

Figure 6-35: Maximum compressive stress in concrete [MPa], linear ULS b

## 6.2 Non-linear analysis

The non-linear analyses are displayed with graphics of the load combinations returning highest bending moment and highest degree of utilization. None of the analyses result in fully utilized columns. Figure 6-36 display a typical deformed shape in all non-linear analysis, here represented by LC 1554 from the non-linear ULS b analysis. The visualization is highly enlarged.

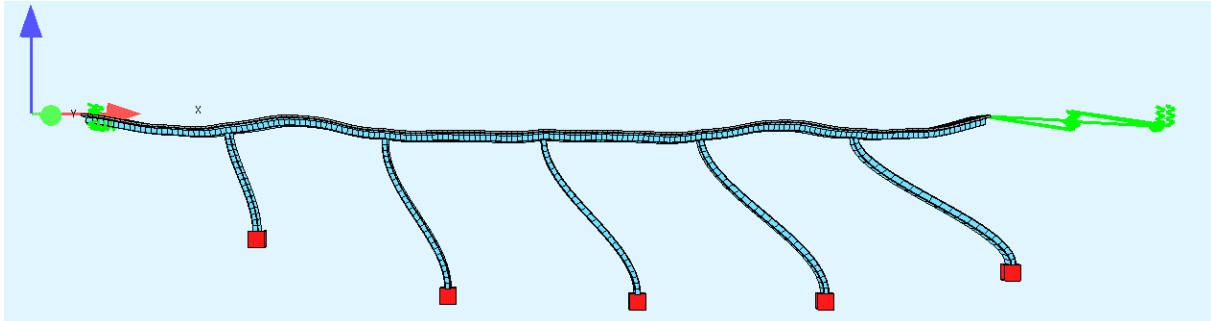

Figure 6-36: System visualization in SSD of LC 1554, non-linear ULS b

### 6.2.1 Service limit state

The load cases giving the highest bending moment in the non-linear analysis for service limit state is load case 1563 with 3286 kNm. With a design capacity of a bit less than 10 851 kNm in the end, the capacity is 30% utilized. The load case returning highest degree of utilization is LC 1626, with 50,1% utilized capacity at top of column 5. Figure 6-37 shows the load combination of LC 1563. The resulting required reinforcement is shown in Figure 6-38, accumulating to 9 855,3kg in all columns. Crack control is not conducted.

```

LC 1563 FACD 1.0 titl 'TH3' $ FACD activates g_1
LCC 2 fact 1 PLC YES $ g_2, Parapet walls
LCC 3 fact 1 PLC YES $ g_2 Railings
LCC 4 fact 1 PLC YES $ g_2 Approach slaps,
                        $ end diaphragms, ballast wall
LCC 5 fact 1 PLC YES $ g_2 Asphalt
LCC 50 fact 1 PLC YES $ prestress
LCC 10151 fact 0.5 $ gr1a
LCC 94 fact 0.6 $ Temp
End

```

Figure 6-37: LC 1563 which return max my in non-linear SLS combination

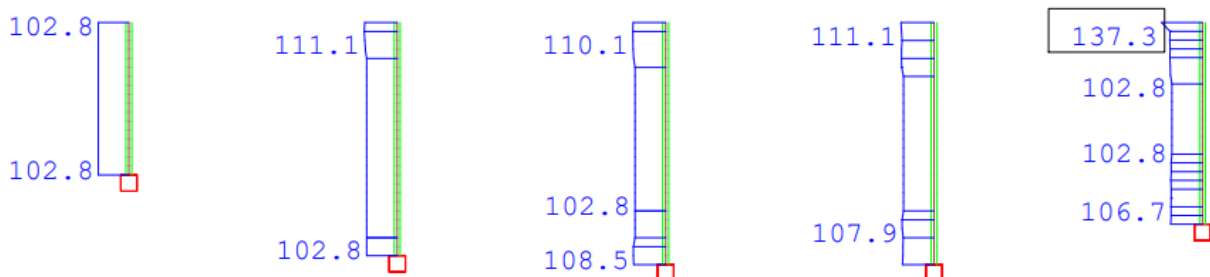

Figure 6-38: Required longitudinal reinforcement [cm<sup>2</sup>/m], non-linear SLS

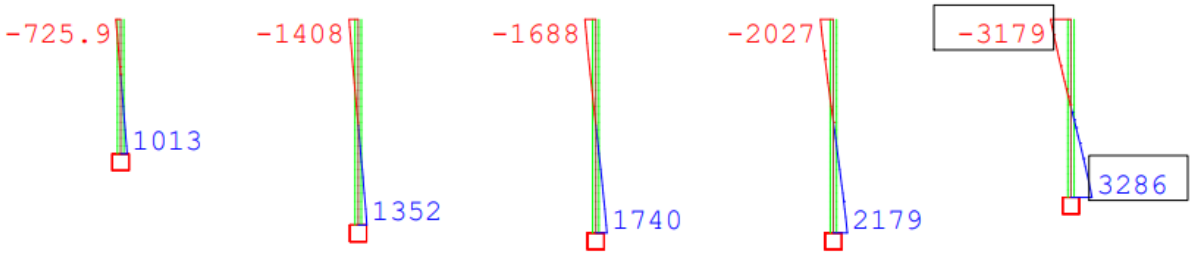

Figure 6-39: Maximum bending moment  $M_y$  [kNm], non-linear SLS LC 1563

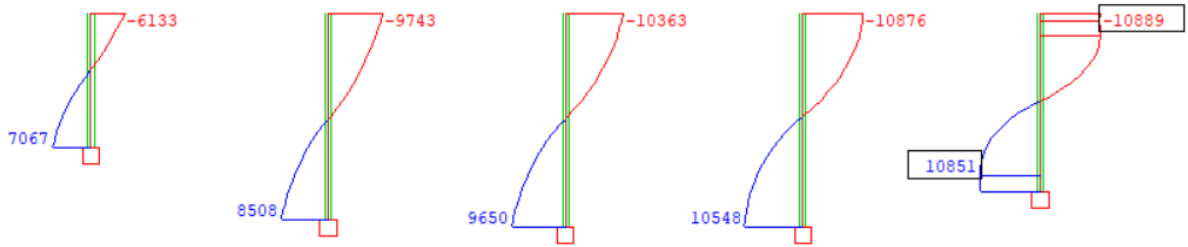

Figure 6-40: Design capacity  $M_y$  [kNm], non-linear SLS LC 1563

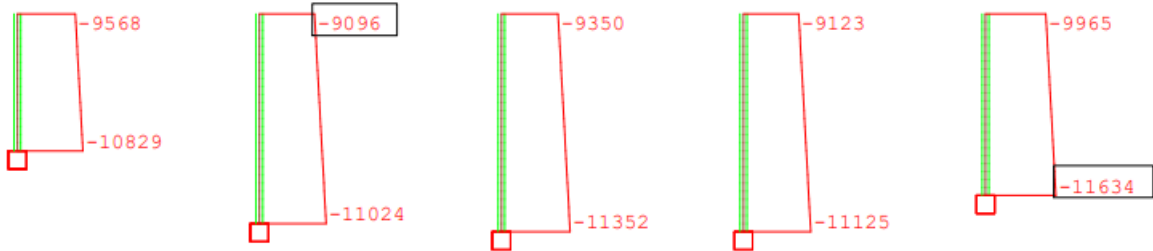

Figure 6-41: Axial force  $N$  [kN], non-linear SLS LC 1563

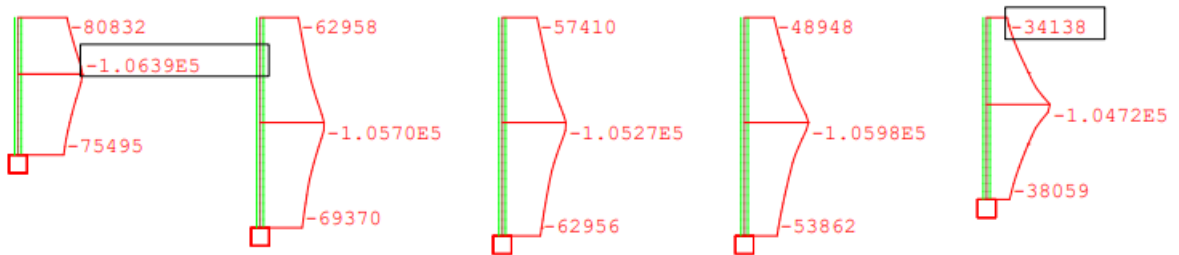

Figure 6-42: Design axial force  $N$  [kN], non-linear SLS LC 1563

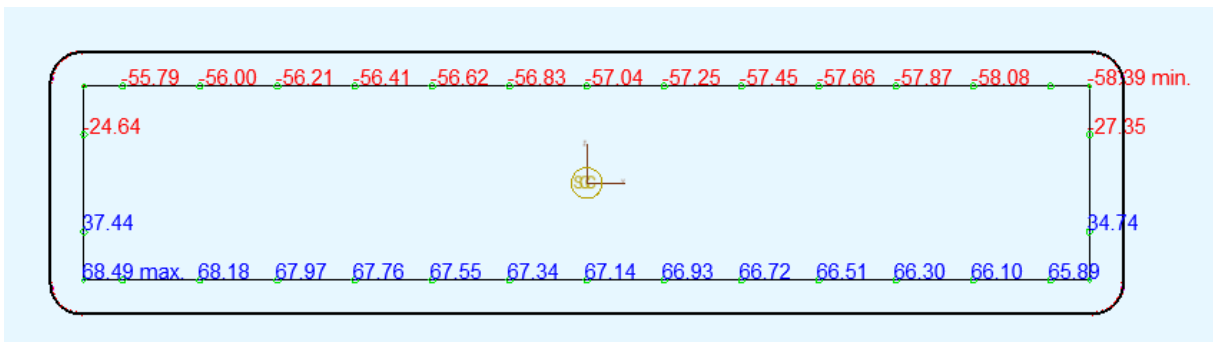

Figure 6-43: Stress distribution in reinforcement in top of column 5 [MPa], non-linear SLS LC 1626

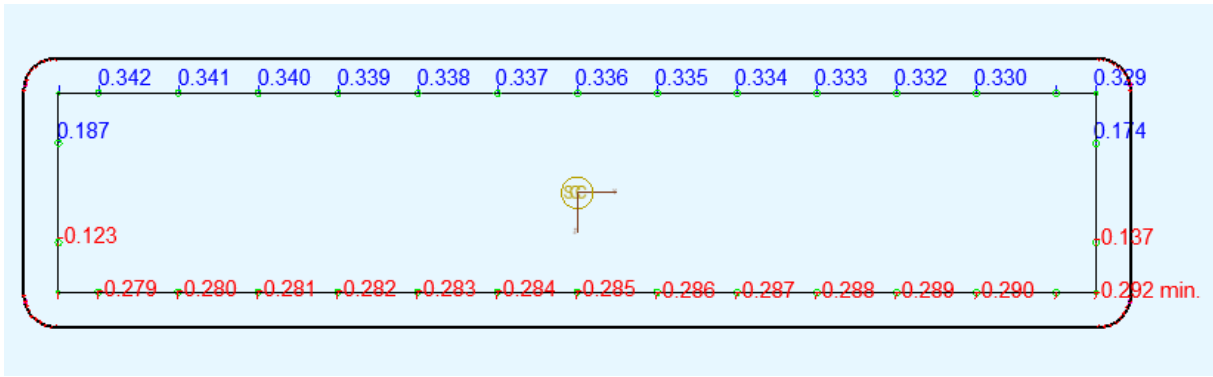

Figure 6-44: Strain distribution in reinforcement in top of column 5 [%], non-linear SLS LC 1626

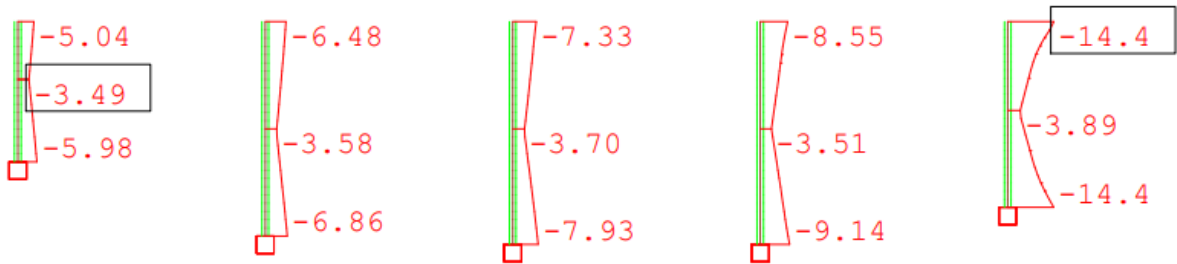

Figure 6-45: Maximum compressive stress in concrete [MPa], non-linear SLS LC 1536

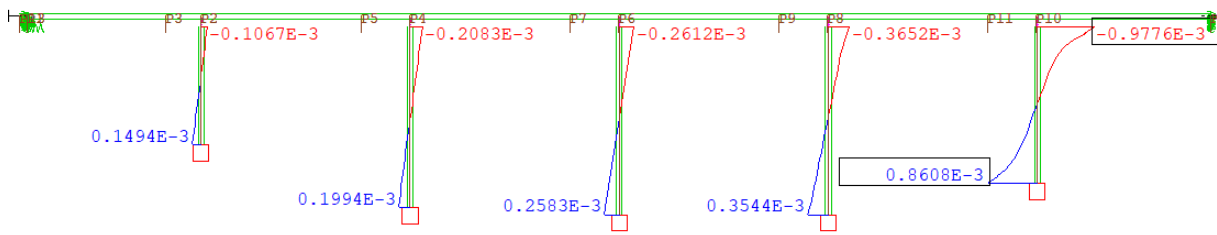

Figure 6-46: Total curvature  $k_y$  [1/m], non-linear SLS LC 1563

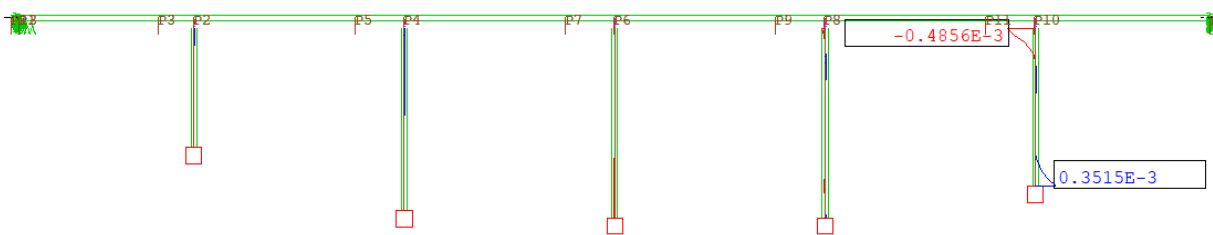

Figure 6-47: Plastic curvature  $y$  [1/m], non-linear SLS LC 1563

## 6.2.2 Ultimate limit state 6.10a

In the combination 6.10a for ultimate limit state, load case 1536 returns the highest bending moment of 3137 kNm. The capacity is significant higher, making the columns maximum 36% utilized. Figure 6-48 shows the loads in the combination. The required accumulating steel reinforcement is 9 786,14 kg.

```

LC 1536 FACD 1.0 titl 'TH3' $ FACD activates g_1
LCC 2 fact 1 PLC YES $ g_2 Parapet walls
LCC 3 fact 1 PLC YES $ g_2 Railings
LCC 4 fact 1 PLC YES $ g_2 Approach slabs
                        $ end diaphragms, ballast wall
LCC 5 fact 1 PLC YES $ g_2 Asphalt
LCC 50 fact 1.1 PLC YES $ prestress
LCC 10148 fact 0.945 $ gr1a
LCC 94 fact 0.84 $ Temp
    
```

Figure 6-48: LC 1536 which returns max My in non-linear ULS a combination

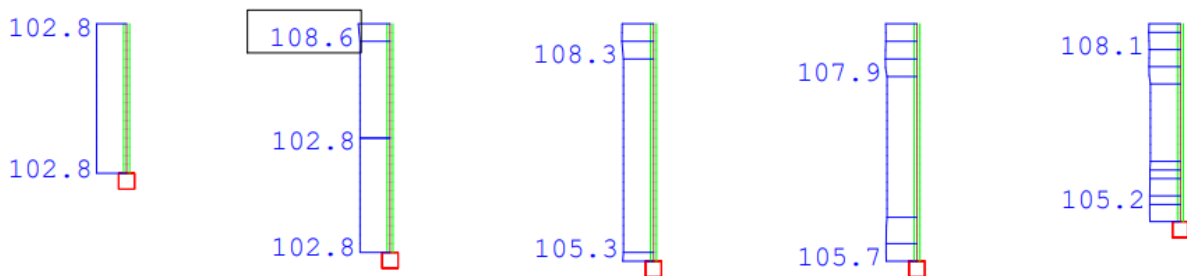

Figure 6-49: Required longitudinal reinforcement [cm²/m], non-linear ULS a



Figure 6-50: Maximum bending moment My [kNm], non-linear ULS a

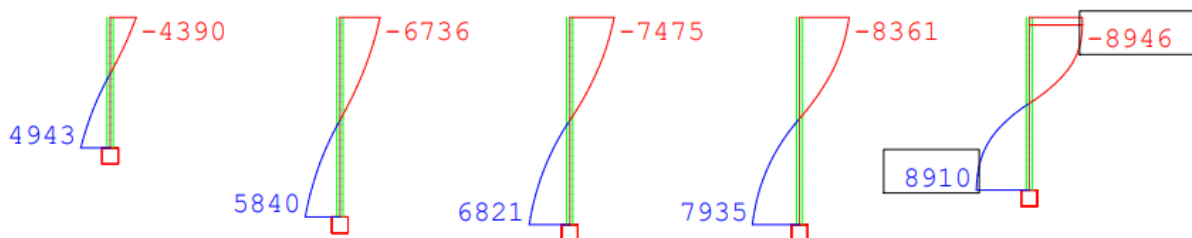

Figure 6-51: Design capacity My [kNm], non-linear ULS a

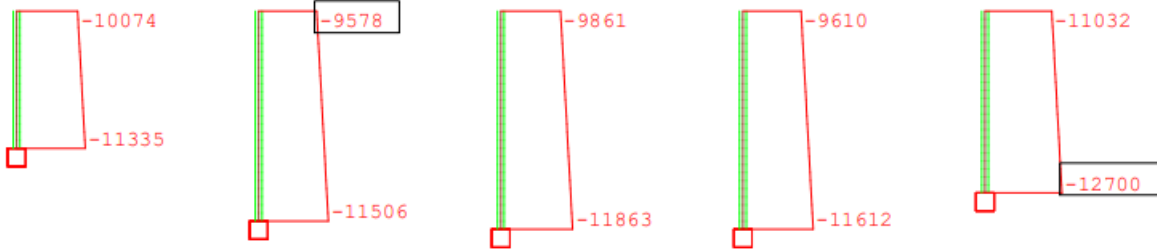

Figure 6-52: Axial force N [kN], non-linear ULS a

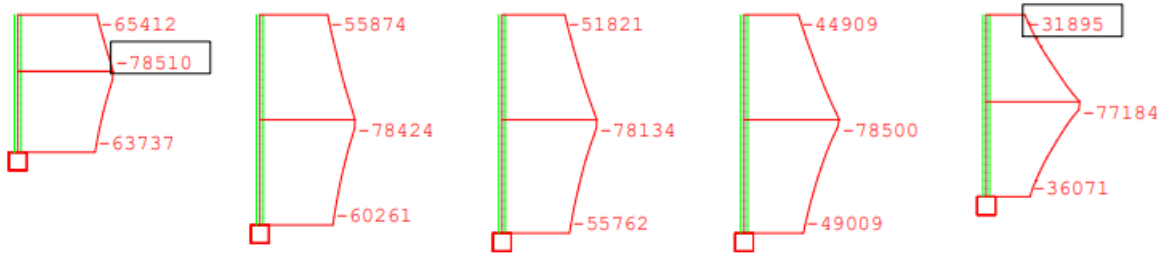

Figure 6-53 Design capacity axial force N [kN], non-linear ULS a

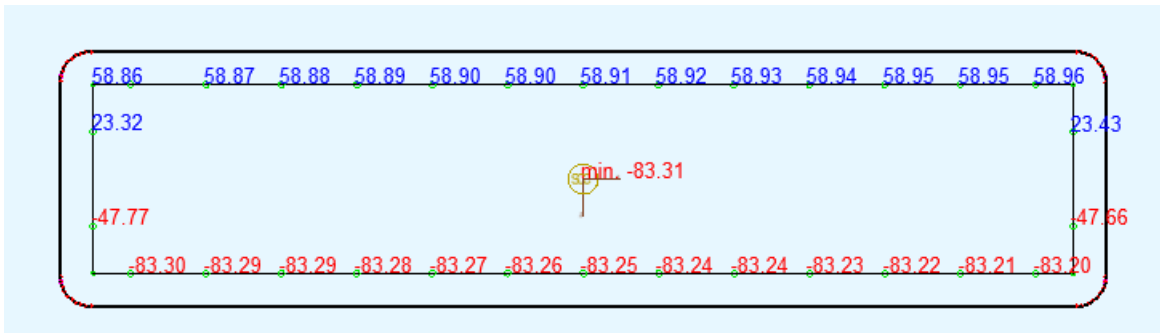

Figure 6-54: Stress distribution in reinforcement in top of column 5 [MPa], non-linear ULS a LC 1536

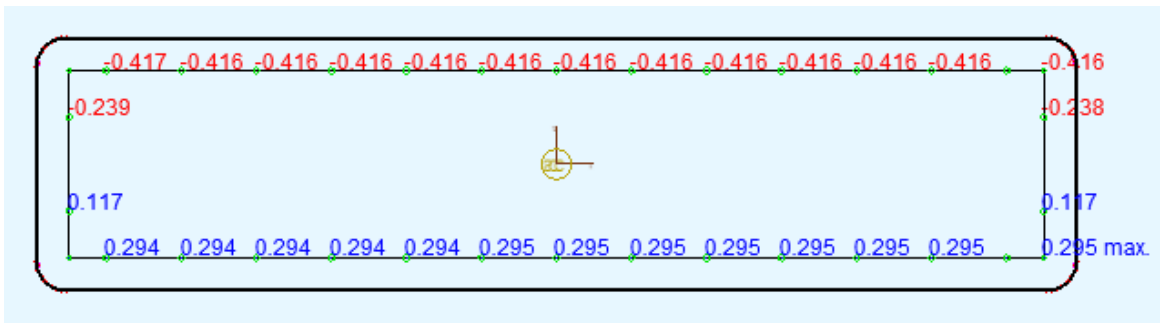

Figure 6-55: Strain distribution in reinforcement in top of column 5 [%], non-linear ULS b LC 1536

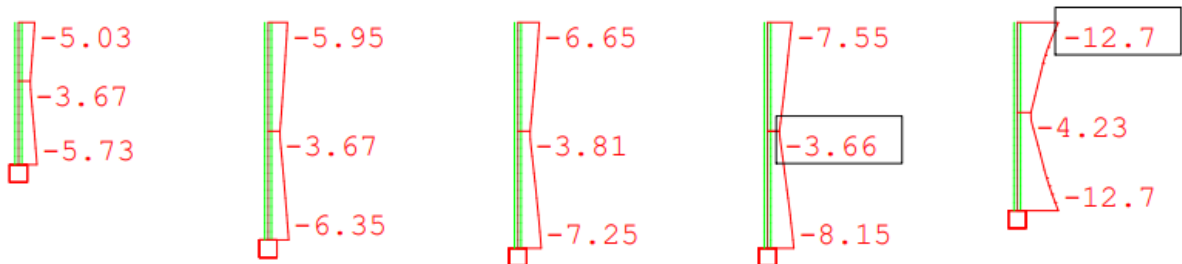

Figure 6-56: Maximum compressive stress in concrete [MPa], non-linear ULS a LC 1536

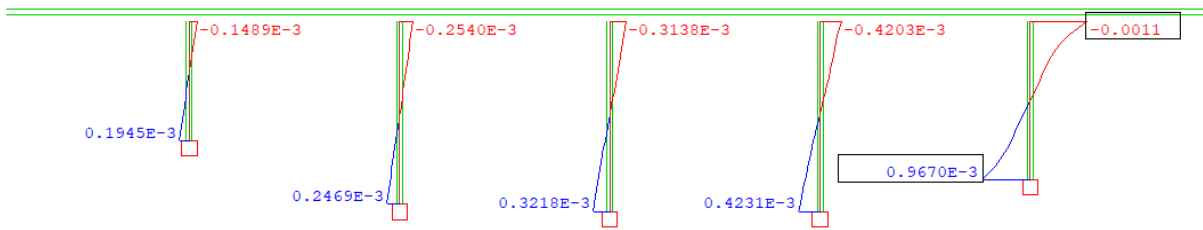

Figure 6-57: Total curvature  $k_y$  [1/m], non-linear ULS a LC 1536

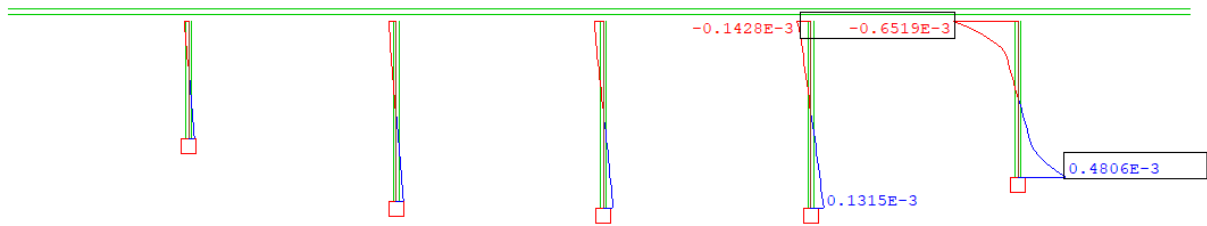

Figure 6-58: Plastic curvature  $y$  [1/m], non-linear ULS a LC 1536

### 6.2.3 Ultimate limit state 6.10b

The non-linear analysis in ultimate limit state, equation 6.10b LC 1554, return a maximum bending moment of 3541kNm. The design capacity is 8938kNm, which means the reinforcement is not utilized. LC 1635 is the load case with highest utilization with 41,1%. Figure 6-60 shows the required longitudinal reinforcement, accumulating to 9 820,72kg. The reinforcement experiences relative high stress with 111MPa, but low strains, 0,7‰ at its maximum. In the concrete, the compressive stress is sufficient low.

```

LC 1554 FACD 1.0 titl 'TH3' $ FACD activates g_1
LCC 2 fact 1 PLC YES $ g_2 Parapet walls
LCC 3 fact 1 PLC YES $ g_2 Railings
LCC 4 fact 1 PLC YES $ g_2 Approach slabs
                    $ end diapragms, ballast wall
LCC 5 fact 1 PLC YES $ g_2 Asphalt
LCC 50 fact 1.1 PLC YES $ prestress
LCC 10150 fact 0.945 $ gr1a
LCC 94 fact 1.2 $ Temp

```

Figure 6-59: LC 1554 which returns max  $m_y$  in non-linear ULS b combination.

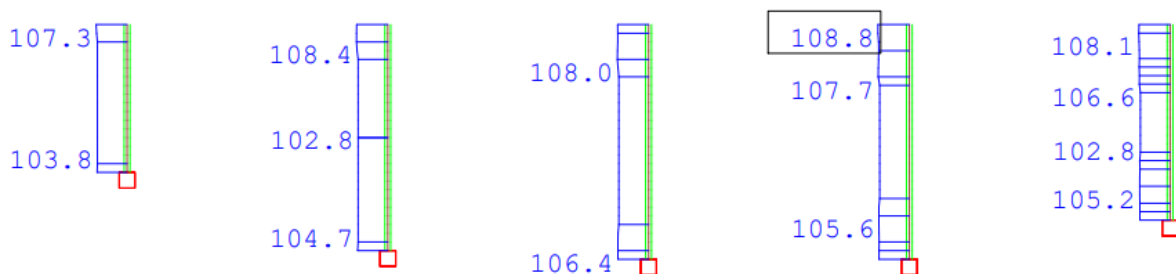

Figure 6-60: Required longitudinal reinforcement [cm<sup>2</sup>/m], nonlinear ULS b

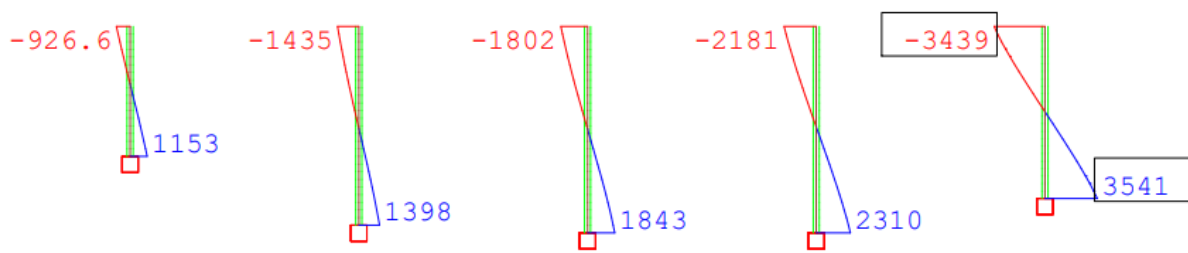

Figure 6-61: Maximum bending moment diagram  $M_y$  [kNm], non-linear ULS b LC 1554



Figure 6-62: Design capacity  $M_y$  [kNm], non-linear ULS b LC 1554

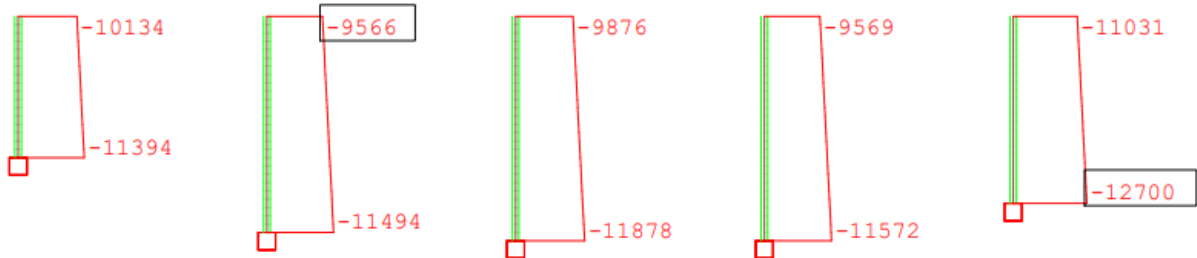

Figure 6-63: Axial force  $N$  [kN], non-linear ULS b LC 1554

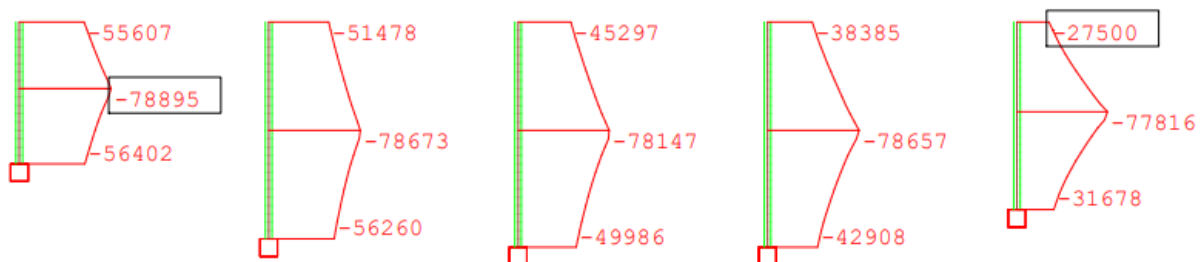

Figure 6-64: Design capacity axial force  $N$  [kN], non-linear ULS b LC 1554

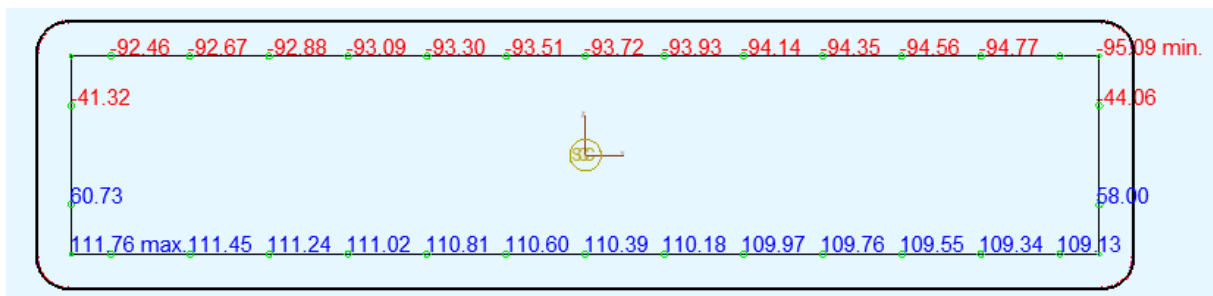

Figure 6-65: Stress distribution in reinforcement at top of column 5 [MPa], non-linear ULS b LC 1635



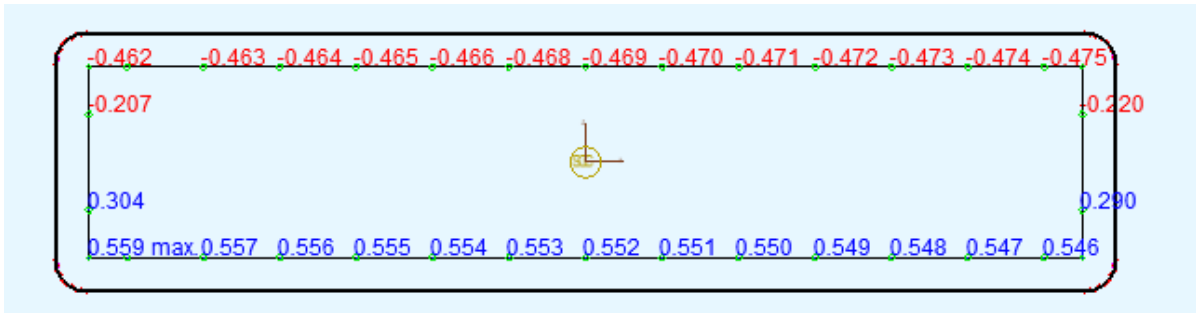

Figure 6-66: Strain distribution in reinforcement at top of column 5 [%], non-linear ULS b LC 1635

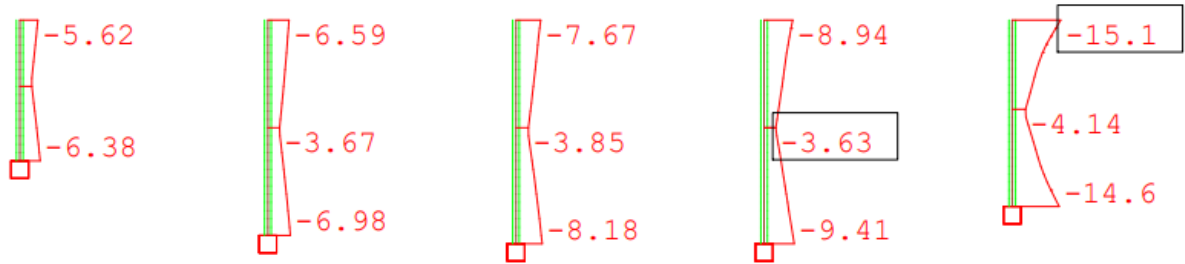

Figure 6-67: Maximum compressive stress in concrete [MPa], non-linear ULS b LC 1635

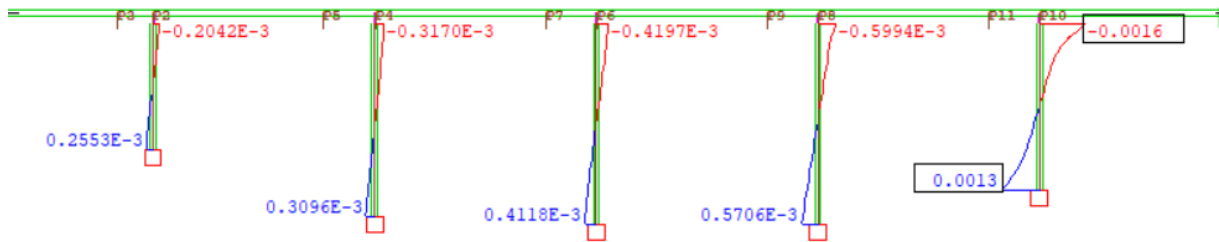

Figure 6-68: Total curvature  $k_y$  [1/m], non-linear ULS b LC 1554

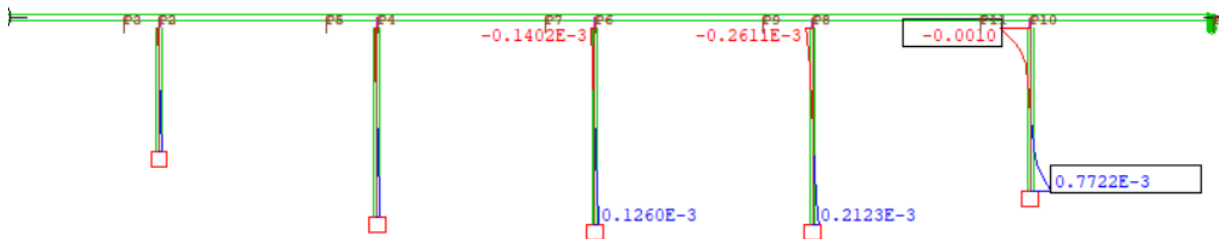

Figure 6-69: Plastic curvature  $\gamma$  [1/m], non-linear ULS b LC 1554

### 6.3 Comparison

To obtain comparable results, some re-calculation has been performed. As the required reinforcement are not similar in linear and non-linear analyses, stresses in reinforcement are calculated to a force by multiplying the cross-section stress and area reinforcement in the critical sections. To compare the non-linear e-modulus, the effective E is divided by the linear E of concrete. In that order, a relative E-modulus can be displayed in graphs for each column. Figure 6-70 shows the dispersion of elements in the respective columns.

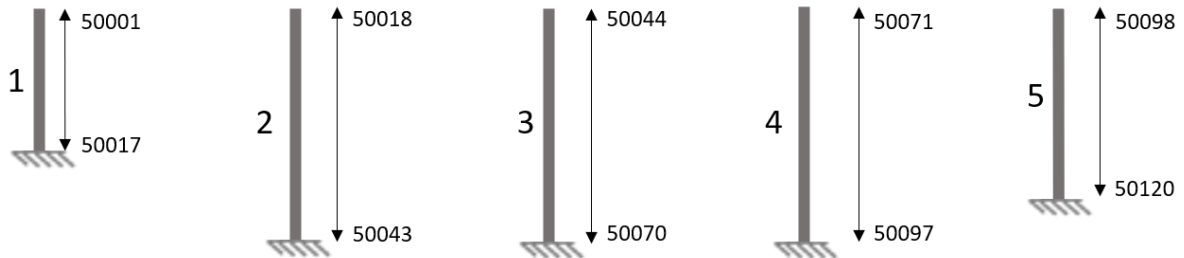

Figure 6-70: Number of elements in columns

#### 6.3.1 Resulting forces

The resulting forces in the critical cross-sections of column 5 are shown in Table 6-1 and Table 6-2. The load combination returning highest bending moments are used.

Table 6-1: Comparison of the resulting forces and capacities at top of column 5

Resulting forces in element 50098 (x=0)	SLS		ULS a		ULS b	
	Linear	Non-linear	Linear	Non-linear	Linear	Non-linear
Med [kNm]	- 4 652	- 3 179	- 6 973	- 3 082	- 8 369	- 3 439
Mrd [kNm]	- 4 652	- 10 889	- 6 975	- 8 946	- 8 346	- 8 953
Ned [kN]	- 8 912	- 9 965	- 13 517	- 11 032	- 12 038	- 11 031
Nrd [kN]	- 8 911	- 34 138	- 13 520	- 31 895	- 12 235	- 27 500

Table 6-2: Comparison of resulting forces and capacities at bottom of column 5

Resulting forces in element 50120 (x=1)	SLS		ULS a		ULS b	
	Linear	Non-linear	Linear	Non-linear	Linear	Non-linear
Med [kNm]	4 793	3 286	7 013	3 137	8 443	3 541
Mrd [kNm]	4 793	10 851	6 707	8 910	8 432	8 938
Ned [kN]	- 10 467	- 11 634	- 15 654	- 12 700	- 14 240	- 12 700
Nrd [kN]	- 10 467	- 38 059	- 15 769	- 36 071	- 14 081	- 31 678

### 6.3.2 Design

**Table 6-3: Comparison of accumulated reinforcement**

Limit state	Linear Asl [cm <sup>2</sup> /m]	Linear [kg]	Non-linear Asl [cm <sup>2</sup> /m]	Non-linear [kg]	Difference in kg
SLS	12 577,34	9 894,82	12 527,78	9 855,30	0,4 %
6.10a	12 465,33	9 805,90	12 438,93	9 786,14	0,2 %
6.10b	12 799,80	10 052,60	12 482,75	9 820,72	2,3 %

**Table 6-4: Comparison of required reinforcement in top of column 5**

Limit state	Linear Asl [cm <sup>2</sup> /m]	nØ20	Non-linear Asl [cm <sup>2</sup> /m]	nØ20	Difference in n
SLS	198,4	64	137,3	44	31 %
6.10a	142,0	46	108,1	35	24 %
6.10b	211,7	68	108,1	35	49 %

### 6.3.3 Material properties

**Table 6-5: Comparison of material properties in element 50098**

Material Parameters in critical section 50098 at top of column 5	SLS		ULS a		ULS b	
	Linear	Non- linear	Linear	Non- linear	Linear	Non- linear
Compressive stress in concrete [MPa]	23,4	14,4	25,5	12,7	25,5	15,1
Stress in reinforcement [MPa]	214	68,5	439	83,3	438,3	111,8
Strain in reinforcement [‰]	1,07	0,342	7,95	0,417	7,00	0,559

**Table 6-6: Comparison of force in steel reinforcement in element 50098(x=0)**

Force in steel at critical cross-section 50098(x=0)	SLS		ULS a		ULS b	
	Linear	Non-linear	Linear	Non- linear	Linear	Non- linear
Asl [cm <sup>2</sup> ]	198,4	137,3	142,0	108,1	211,7	108,1
Stress in reinforcement [N/mm <sup>2</sup> ]	214,4	68,5	439,0	83,3	438,3	111,8
Force in reinforcement [kN]	4 253,7	940,51	6 223,80	900,47	9 278,81	1 208,56
Limiting force [kN] F <sub>yd</sub> =469,6MPa	9316,86	6447,61	6668,32	5076,38	9941,43	5076,38
Utilization [%]	46 %	15 %	93 %	18 %	93 %	24 %

Table 6-7: System properties in the non-linear analyses

Material properties in cross-section 50098(x=0)	Non-linear SLS	Non-linear ULS a	Non-linear ULS b
Bending moment My [kNm]	3 286	3 137	3 541
Asl [cm <sup>2</sup> ]	137,3	108,1	108,1
Stress in steel [MPa]	68,5	83,3	111,8
Strain in steel [‰]	0,342	0,417	0,559
E-modulus of columns [MPa]	18 801	13 758	12 030
Total curvature ky [1/m]	-0,00097	-0,0011	-0,0016
Plastic curvature y [1/m]	-0,486*10 <sup>-3</sup>	- 0,652*10 <sup>-3</sup>	0,0010

Table 6-8: E-modulus at top, bottom and middle for column 5, SLS: LC 1509 ULSa: LC 1572 ULSb: LC 1554

Element nr.	SLS e-modulus [MPa]	ULS a, E-modulus [MPa]	ULS b, E-modulus [MPa]
50098 (X=0)	18 801	13 758	12 030
50109 (X=0)	38 184	25 395	25 386
50120(X=0,978m)	18 553	12 503	12 024

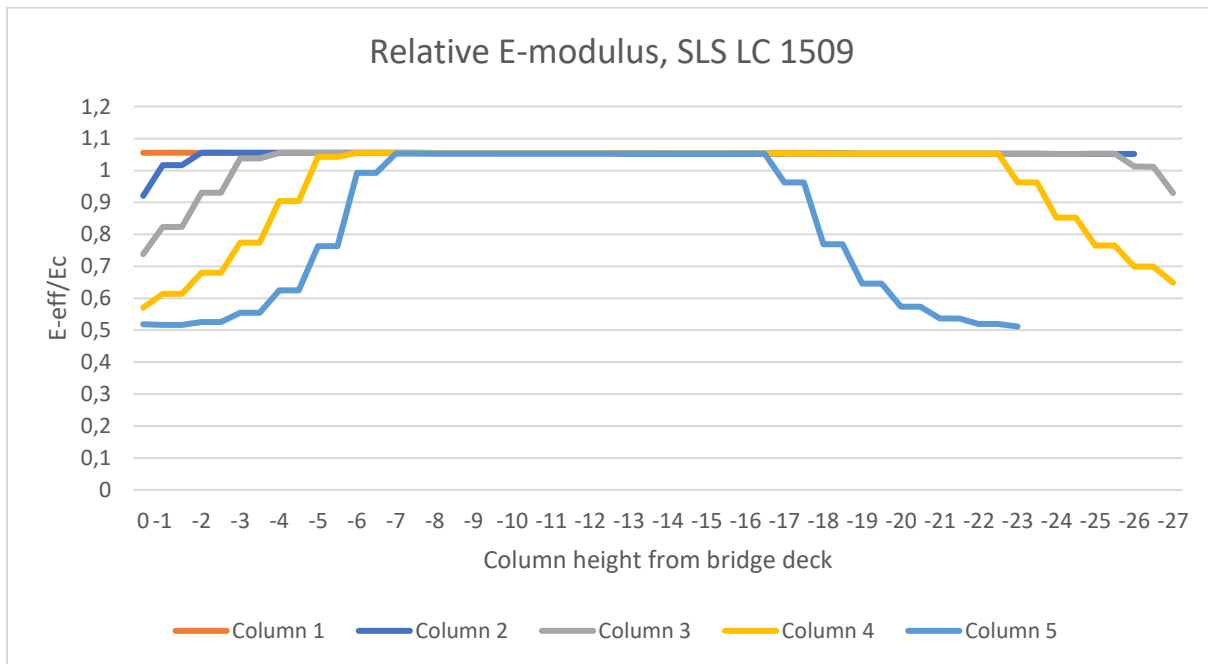
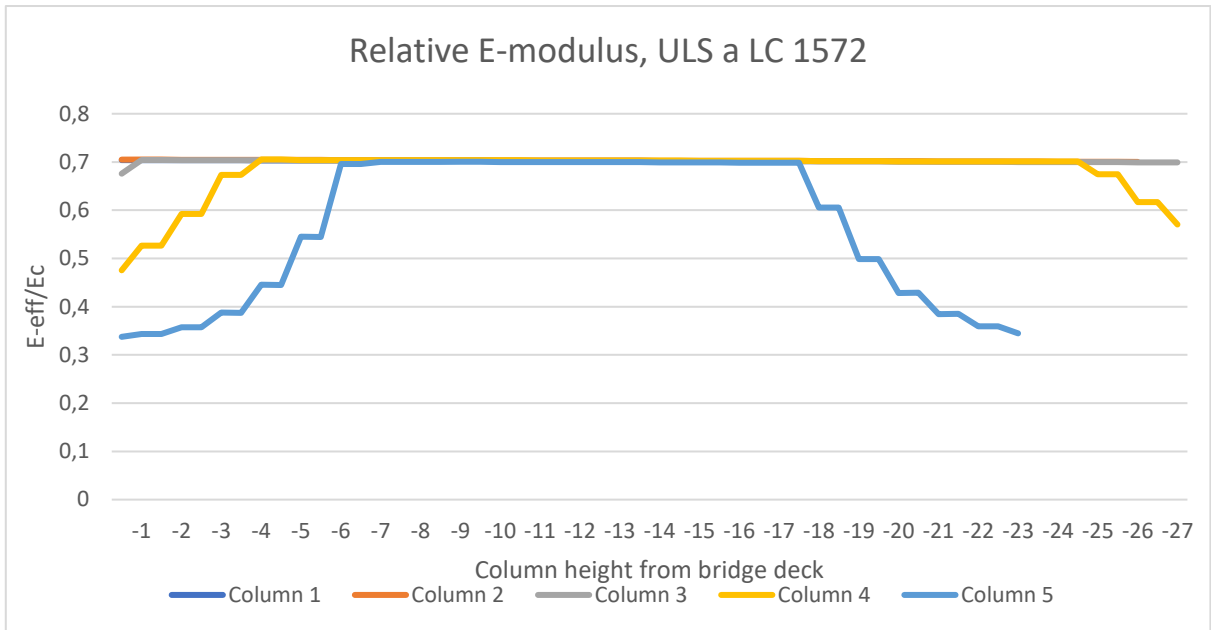
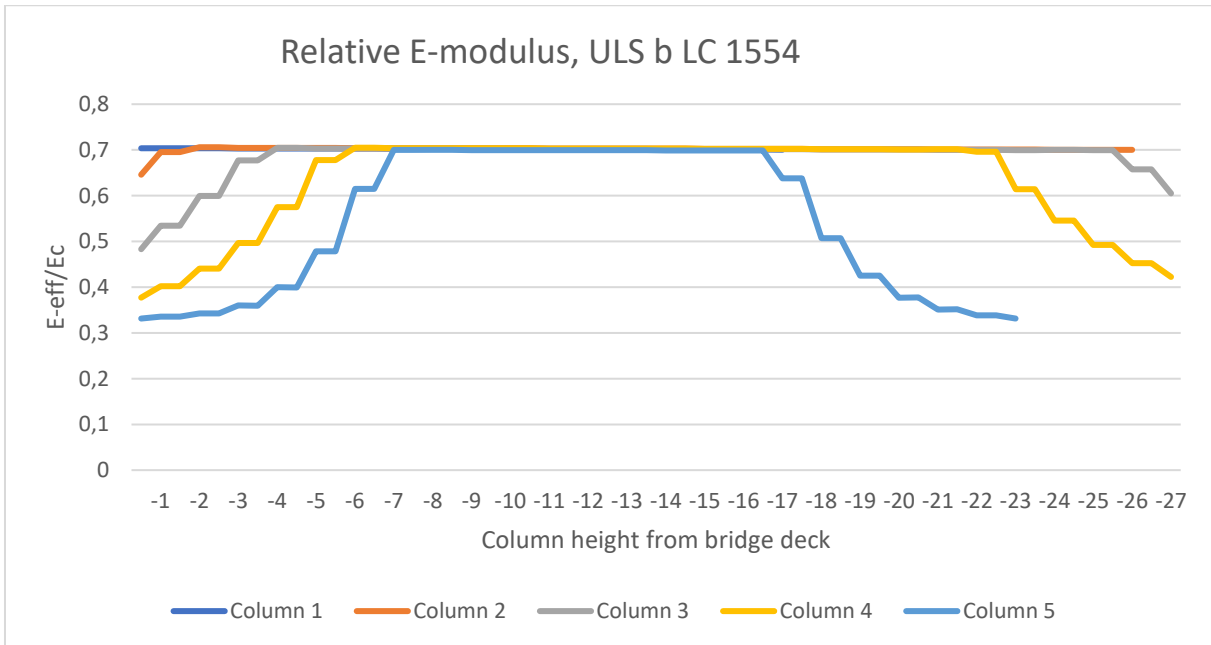

Figure 6-71: Relative E-modulus per column, SLS LC 1509



**Figure 6-72: Relative E-modulus of columns, ULS a LC 1572**



**Figure 6-73: Relative E-modulus of columns, ULS b LC 1554**

## 7. Discussion

---

### 7.1 Linear analyses

The linear analysis for serviceability is successfully designed for limiting crack width of 0,39mm, indicated by the concrete stresses which are just below its limits. Maximum utilization of bending moment and axial force in column 5 demonstrate that the column is on verge of failure, and the absolute minimum required reinforcement is provided. As of the forces, the stress in the reinforcement are also high, but not yielding.

In the check of ultimate limit states, similar pattern occurs, with high stresses and maximum utilization. Both the concrete and reinforcement stress reach its maximum limit, announcing that the columns are on the limit of failure and the minimum required reinforcement is provided also here. Realistically, there should be a margin in the capacities, but the results are nonetheless adequate for the present objective.

### 7.2 Non-linear analyses

The pattern in the non-linear analyses are similar in all design limit states. The columns are not fully utilized regarding neither bending moment nor axial force, which also is displayed in the material properties. In the serviceability check, crack width control is not conducted but may be exceeded as of the ductile results. The SLS analysis is based on a different curve than the ULS analyses and are therefore not directly comparable.

Geometrical non-linearity is based on deformation of an elastic body, which means equilibrium is found regarding the deformed shape. In combination with non-linear material behaviour, i.e. the no longer constant E-modulus, the columns counteract the applied loads by becoming ductile and deform. As the stiffness are a function of the deformation, an iterative process is conducted to provide equilibrium in the system equations. Thus, instead of increasing the amount reinforcement in critical sections, the columns deform to absorb larger forces, as displayed in Table 6-7. Due to the deformation, the stresses raise, and the stiffness is reduced. When higher loads are applied, in example from ULS a to ULS b, the reinforcement is higher utilized and deformations slightly higher.

By calculation for equilibrium in the already deformed shape, the extra eccentricity adds extra bending moment. However, as the bridge deck is deformed, it absorbs some of the force which normally is transferred to the column, leading to lower forces acting on the columns. On the contrary, this effect cannot be significant, as the bridge deck is heavily compressed by the pre-stressing.

As a result of the non-linear behavioural combinations, less forces are needed to reach higher deformations. With concrete being a brittle material, relatively large deformations are not ideal. The brittle characteristics makes concrete susceptible for cracking, which expose the reinforcement for the surrounding environment. Reinforcement is susceptible to corrosion, which would lead to degradation of the steel. Consequently, the whole structure would degrade and eventually fail. However, degradation of concrete structure is another subject which is not covered in the present objectives. Although in this case, as the reinforcement is barely utilized the structure would arguably have sufficient capacity to stand some degradation. In a complete design including all real loads, the situation could be different.

### 7.3 Comparison

The results display a difference of global required reinforcement between linear and non-linear analysis as expected. The differences were small, almost neglectable, as expected, varying from 0,2 to 2,3%. In critical section, however, the difference in required reinforcement was substantial. The difference ranging from 24 to 49% and 35 to 68 number of  $\varnothing 20$  bars, was not expected.

A combination of the material and geometrical non-linearity proved to behave in respect of different terms than the linear approach. With the constantly updating E-modulus, the non-linear columns adapted to the applied forces through ductility and deformations in contrast to forming equivalent internal forces in the linear. As the non-linear columns can deform, smaller internal forces were formed to withstand the applied loads, which also explain the lower required reinforcement in critical sections.

The maximum stresses in the reinforcement are not directly comparable and was therefore converted to a force. The linear reinforcement experiences a significantly higher force than the non-linear. With the ductile behaviour, higher strains can be reached at lower stress rates, as well as the deformation absorbs some of the forces.

The non-linear behaviour resulted in lower internal forces in the columns, even though the deformed shape added extra moments due to higher eccentricities. Equilibrium is found considering the deformed shape and in combination with the material non-linearity, the applied loads and internal forces are balanced by the stiffness matrix that are constantly changed and re-assembled. Also, the already deformed bridge deck is reducing the internal forces of the columns, where the bridge deck absorbs applied loads through creep and deformations. This effect is not significant though, as the bridge deck is heavily compressed by the pre-stressing. In the linear analyses, all internal forces are transferred to the column.

Throughout all the analyses, column 5 experienced the highest bending moments, resulting in highest level of utilization. Column 5 are the furthest column from the pinned support, and subsequently experience the largest effects of the horizontal forces. Figure 7-1 and Figure 7-2 shows this effect, where the system is excited by the temperature combinations LC 95 and LC 94 respectively. LC 95 display extraction of the bridge deck and LC 94 contraction, both subsequently affecting the columns, and number 5 especially.

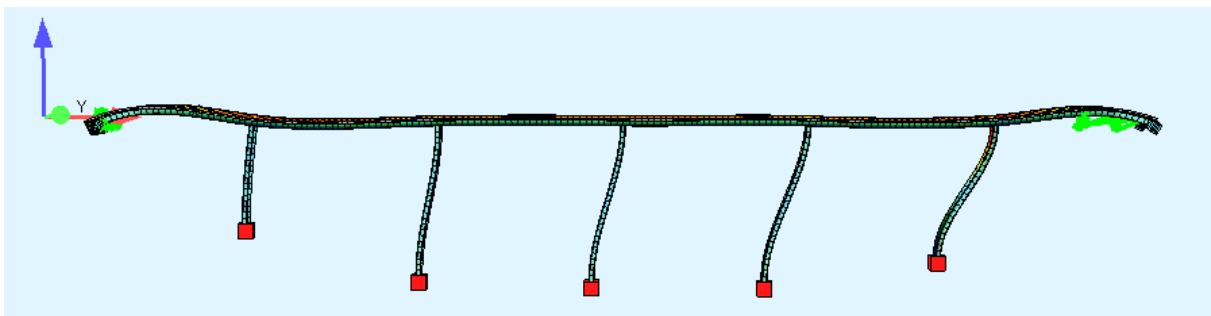

Figure 7-1: Visualization of the system excited of temperature combination LC 95

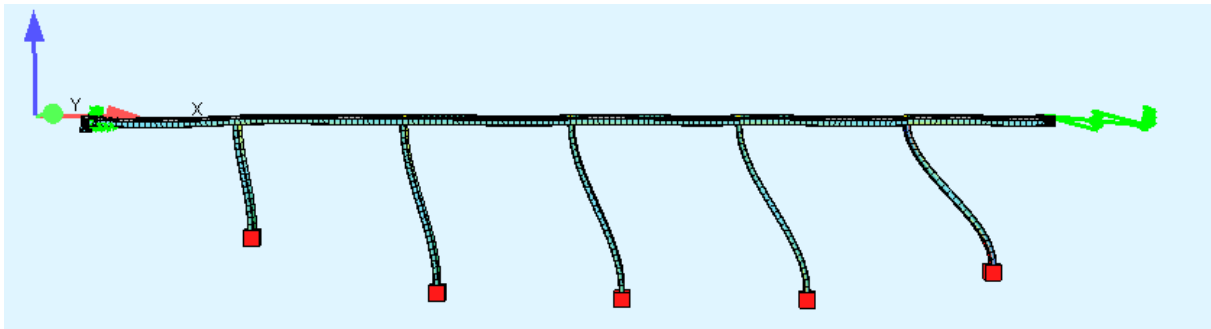

Figure 7-2: Visualization of the system excited of temperature combination LC 94

## 7.4 Modelling

Constructing the non-linear analysis was as expected the most challenging part of the thesis. As it is not usually practised, no design procedure is standardized in the same way as linear analyses. Non-linear analyses are barely used in design, which explain why the information was at times unclear and insufficient. In example, literature states both that mean material stress-strain curves should be used instead of characteristic (Gilbert), and that characteristic for ultimate limit state should be used (Sofistik example).

When comparing the linear and non-linear analyses, time-consume must be considered. The linear analysis is performed in seconds, while the full non-linear analysis is performed in approximately two days. The main reason of the difference is the validity of superposition in the linear analysis which simplifies the process of finding the least favourable combination for the software. As mentioned earlier, the non-linear analysis requires 1539 load combinations to be checked in full, compared to the automatic process in the linear analysis. When performing a non-linear analysis, the global stiffness matrix must be recalculated several times, compared to once in the linear analysis. As the assembly of the global stiffness matrix demand 90 percent of the CPU time (processing time), a full non-linear analysis is considerably demanding. In a complete non-linear analysis, including all loads applied in a complete design, the amount of possible load combination will be significantly higher, hence the time-consume will increase substantially.

Also, the time-consume of configuring the non-linear analysis must be taken into account. The linear analysis process is well documented in the Eurocodes, clear and accessible in the software documentation and practiced daily by engineers. That non-linear global analyses are not a common procedure was obvious when constructing the analysis code in Sofistik. Examples of local non-linear checks in complex structures and of smaller structures was found and used in the process of constructing the global analysis. After constructing the desired setup, the coding software Visual Studio accelerated the physical writing process. Learning an additional software is also time-consuming but compared to manually write almost 100 000 coding lines accurately, it is presumably less toilsome work.

After the non-linear analysis was performed, processing of the results also proved challenging, as the output amount was enormous. All the 1539 different load cases provide individual output for each 120 beam-element. To enable proper analysing of the results, several re-calculations and processing methods was applied. In example, to present the total required reinforcement, the highest registered amount in each element was put together in one design case. This process was not straight forward, as several operations in Sofistik are limited to a specified number of inputs. Therefore, as the REIN command only could store 255 load cases in one design case, the assembly of the required reinforcement design case was first divided into 7 different design cases, before assembled in a final design case.



With the linear analysis being well documented, applied in practice and possible to verify by hand, its results are adequately reliable. The non-linear analyses are hard to validate, the engineer must employ his engineering knowledge to control if the output parameters are reasonable to the expected behaviour. As of the updating stiffness matrix, and generally the non-linear nature of each step in a non-linear analysis, the amount variable increases significantly in comparison to linear analyses. The complexity also increases exponentially as input are added. This makes the construction of the non-linear analyses laborious work, with every input variable being important to compile reliable results. By employing the coding software Visual Studio, not only was the construction of the non-linear analyses accelerated, the reliability of the analyses was also altered by the automated process of the coding software. However, the increase reliability depends on the coding being conducted correctly. Nevertheless, compared to manually write all the almost 100 000 lines, the risk of wrong inputs is arguably lower with a coding software.

## 7.5 Sources of error

With complex and large analyses, there is always a risk of errors. Sofistik is extremely sensitive, in the degree that even the smallest misplacement of a load or a member can cause instability and consequential errors. Computational errors are therefore vital to avoid in order to keep the reliability of the analysis. The required sensitivity increases the time-consume of the engineer, as input and geometry must be carefully programmed.

Troubleshooting in Sofistik has proven to be time-consuming. The software produces an output report which display all output specified in each task, in addition to highlight errors and warnings. This is a helpful function, but as the structure and software are as complex as it is, the warnings and errors seldom highlight the real cause of failure. In example, when testing for the setup of the non-linear analysis, problems with convergence always occurred almost no matter the input. By thoroughly examination of every Teddy task and geometric input in Sofiplus-X, a few loads were found to be placed the smallest distance possible out of position, and therefore causing instability and no convergence. Another example is when the user figured out that BEAM-elements with tendons is not supported for geometric non-linear analysis. The same error, with no convergence and the structure having trouble absorbing energy, even with large amount of reinforcement being used. The error message only specified troubles with convergence and alternatives that could alter the iteration. After contacting the support, the error was found. These examples highlight the complexity and size of a structure as Røydalen Bridge. Even with a functioning report system in place, the real source of error can be numerous hidden details. However, the decisive parameter is often the user and his computation. The software provides enormous possibilities if the user knows who to utilize it.

Towards the end of the non-linear process it became clear that QUAD-elements are better suited than BEAM-elements for non-linear analysis in Sofistik. After spending months gaining knowledge of the software and troubling with non-linear analysis, the support notified that beam-elements including tendons was not applicable to non-linear analyses. In hindsight, it can be argued that a change from BEAM-elements to QUAD-elements should be carried out early, as the documentation for non-linear analysis are superior for QUAD- compared to BEAM-elements. However, the documentation is not completely aligned with the information from support as the ASE manual states that *"Tendons defined in the QUAD elements with the program TENDON can be used only in geometrically linear analysis"* [25]. Although there might be another way, the information is at times unclear. As this inconvenience was first discovered late in the thesis process after contacting support, there was not enough time to make the change.

## 8. Conclusion

---

The aim of the thesis was to compare linear and non-linear behaviour of the prestressed concrete bridge, Røydalen Bridge. Throughout the process, the target was to answer the research question:

“What is the difference in amount of required reinforcement when designing a bridge based on a linear analysis versus a material and geometric non-linear analysis?”

With the final results, the research question is partially answered. Non-linear analyses require less reinforcement than linear. The difference is marginal globally accumulated, but significant in critical sections. As the non-linear analyses are less reliable and pose ductility to a brittle material, the linear assumptions are sufficiently accurate and pose greater security. The research question is partially answered, as the results display the difference in required reinforcement of the columns, not the whole bridge.

The analytical model was verified to be adequately equal to the real bridge through hand calculations. Comparison of both geometric cross-section constants and calculation of a static indeterminate system proved adequate results.

Completing the linear analyses proved different than verification. Too low amount of minimum reinforcement furnished fully utilized columns on the limit of failure. The provided reinforcement is the absolute minimum required, which is not ideal but sufficient for the objective of the thesis.

The non-linear analyses delivered both expected and unexpected results. Stresses in reinforcement did not increase from the linear in ultimate limit states as expected. The constantly changing E-modulus proved to be the governing parameter as the system found equilibrium through iterations between stiffness and deformations. Unexpected was also the low level of utilization of internal forces, which was a result of the ductile behaviour. In the end, the non-linear analyses required less reinforcement as expected.

During the thesis, the objective was slightly altered, as a limitation to the software occurred. The focus was changed from the whole bridge to the columns, as pre-stressed beam-elements could not be analysed with non-linear geometric behaviour in Sofistik. In that regard, the aim of gaining practical knowledge of FEM-design of pre-stressed concrete bridges was reduced. However, the linear analysis was performed with prestressing, and knowledge was already gathered. In hindsight, QUAD-elements could have replaced the BEAM-elements, as they seem better suited. As the limitation was discovered in late in the process, the change was not made.

As large potential non-linear analyses may hold, the complexity, security and time-consume is not at a sufficient stage. With the simplicity and degree of accuracy in linear analysis, non-linear global analyses cannot be justified if linear analyses are applicable.

Overall, the research question is answered within the theses limiting conditions. The linear analysis requires more reinforcement but provides a more secure and compatible behaviour to the concrete's brittle characteristics.

## 8.1 Further work

During this thesis, several additional possibilities occurred. Due to the time-consume of constructing the non-linear analysis and the main objectives, these possibilities were not discovered in detail in this report.

- Change to Quad elements could possibly enabled the full global analysis as originally planned, including the pre-stressed bridge deck. However, quad-elements are significant more complex than beam-elements, which would increase the time-consume further. In addition to the re-modelling of the analytical model, the non-linear analyses would be re-configured and performing the non-linear analyses would consume more time with the more complex elements. As the limitation of beam-elements was discovered late in the process, there was not enough time to change.
- Sofistik has two program modules developed for geometrical non-linearity in beams, called STAR2 and STAR3. As the documentation here was limited, ASE-was chosen as the program module. Trying to configure the non-linear analyses in these modules could be interesting.
- As the focus was changed to the columns a comparison of second and third order theory could be interesting as columns normally can be checked in regard to second order theory.

## References

---

- [1] R. I. Gilbert, N. C. Mickleborough and G. Ranzi, *Design of Prestressed Concrete to Eurocode 2*, CRC Press, 2017.
- [2] Z. Zainal, "Case study as a research method," Universiti Teknologi Malaysia - Faculty of Management and Human Resource Development, 2007.
- [3] Standard Norge, NS-EN 1990:2002+A1:2005+NA:2016 Eurocode: Basis of structural design, Standard Norge, 2002.
- [4] A. P. Boresi and R. J. Schmidt, *Advanced Mechanics of Materials - 6th edition*, Wiley, 2003.
- [5] W. Rust, *Non-Linear Finite Element Analysis in Structural Mechanics*, Springer International Publishing, 2015.
- [6] N.-H. Kim, *Introduction to Nonlinear Finite Element Analysis*, Springer US, 2015.
- [7] R. D. Cook, D. S. Malkus, M. E. Plesha and R. J. Witt, *Concepts and applications of finite element analysis - 4th edition*, Wiley, 2002.
- [8] X. Lin, Y. Zhang and P. Pathak, *Nonlinear Finite Element Analysis of Composite and Reinforced Concrete Beams*, Elsevier, 2020.
- [9] N. Veerabhadraiah, "FINITE ELEMENT STUDIES ON DEFORMATION CHARACTERISTICS OF NON-LINEAR MATERIALS IN QUASI-STATIC REGIME," Researchgate.net, 2009.
- [10] E. Carrera, G. Giunta and M. Petrolo, "The Parabolic, Cubic, Quartic, and N-Order Beam Theories," in *Beam Structures*, John Wiley & Sons, Ltd, 2011, pp. 65-72.
- [11] S. I. Sørensen, *Betongkonstruksjoner: Beregning of dimensjonering etter Eurocode 2 - 2nd edition*, akademika forlag, 2013.
- [12] Standard Norge, NS-EN 1992-1-1:2004+A1:2014+NA:2018 Eurocode 2: Design of concrete structures - Part 1-1: General rules for buildings, Standard Norge, 2004.
- [13] G. Ersdal, J. V. Sharp and A. Stacey, "Application of Safety Principles to Structures," in *Ageing and life extension of offshore structures: The Challenge of Managing Structural Integrity*, London, Wiley, 2019, pp. 29-32.
- [14] CEN, Draft of: EN 1992-1-1 Eurocode 2: Design of concrete structures - Part 1-1: General rules - Rules for buildings, bridges and civil engineering structures, Brussels: European Committee for Standardization, 2020 (not published yet) .
- [15] S. Jacobsen, M. Maage, S. Smeplass, E. Sellevold, J. Lindgård, R. Cepuritis, R. Myrdal, Ø. Bjøntegaard and M. Geiker, *Concrete Technology*, NTNU - Norwegian University of Science and Technology - Faculty of Engineering Science and Technology - Department of Structural Engineering, 2016.
- [16] Vegdirektoratet, "Håndbok N400 - Bruprosjektering: Prosjektering av bruer, ferjekaier og andre bærende konstruksjoner," Statens Vegvesen, 2015.
- [17] Standard Norge, "NS-EN 1991-1-5:2003+NA2008 Eurocode 1: Actions on structures - Part 1-5: General Actions - Thermal Actions," 2003.

- [18] Standard Norge, "NS-EN 1991-2:2003+NA:2010," Standard Norge , 2003.
- [19] Statens Vegvesen, "Beregningsveiledning for etteroppspente betongbruer," 2017.
- [20] Standard Norge, NS-EN 1991-2:2003+NA2010 Eurocode 1: Actions on structures - Part 2: Traffic loads on bridges, Standard Norge, 2003.
- [21] D. Childs, "Load Models & Groups to UK National Annex," 2020.
- [22] "Forskrift for trafikklast på bruer, ferjekaier og andre bærende konstruksjoner i det offentlige vegnettet (trafikklastforskrift for bruer m.m.) [Online]," 2017. [Online]. Available: <https://lovdata.no/dokument/SF/forskrift/2017-11-17-1900>.
- [23] Statens Vegvesen (Norwegian Public Roads Administration), "Beregningsveiledning for etteroppspente betongbruer," Vegdirektoratet, 2017.
- [24] SOFiSTiK AG, *SOFiSTiK: Basics*, SOFiSTiK AG, 2020.
- [25] SOFiSTiK AG, *ASE: General Static Analysis of FE Structures*, SOFiSTiK AG, 2020.
- [26] D. Childs, "Bridge Design & Assessment - Tutorial for Temperature Effects in Bridge Decks," 2020. [Online]. Available: <http://bridgedesign.org.uk/tutorial/temperature-effects.php>. [Accessed 9th February 2021].

## Appendices

---

Appendix A – Detail drawings of Røydalen Bridge

Appendix B – Verification of analytical model by hand calculations

Appendix C – Visual Studio code

Appendix D – Report of non-linear ULS b analysis

## Appendix A

### Detail drawings

The detail drawings of Røydalen Bridge are provided by Sweco. The drawings are used as a basis when modelling in Sofistik and in calculation of self-weights.

PROFIL NR.	17500	17550	17600	17650	17700
VERTIKAL KURVATUR			R=10000		
HORIZONTAL KURVATUR			R=-1800		
BREDEUTVIDELSE					
TVERRFALL	H.kj.b.k.				
	V.kj.b.k.				
PROFIL H.					
TERRENG H.					

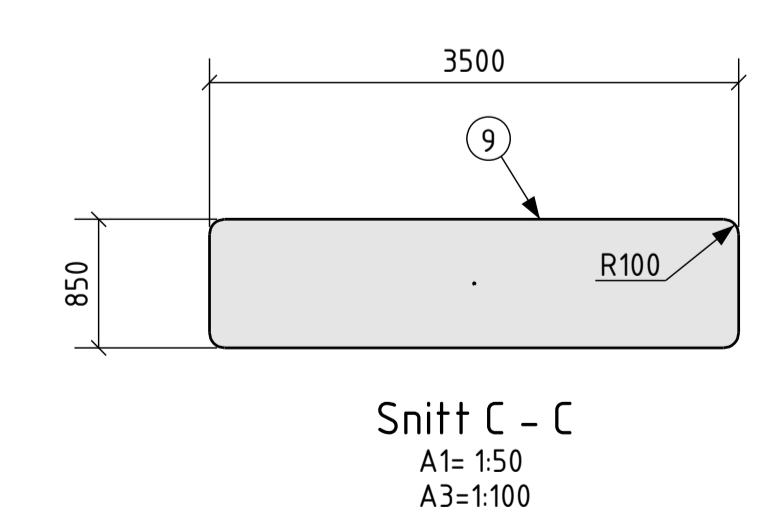
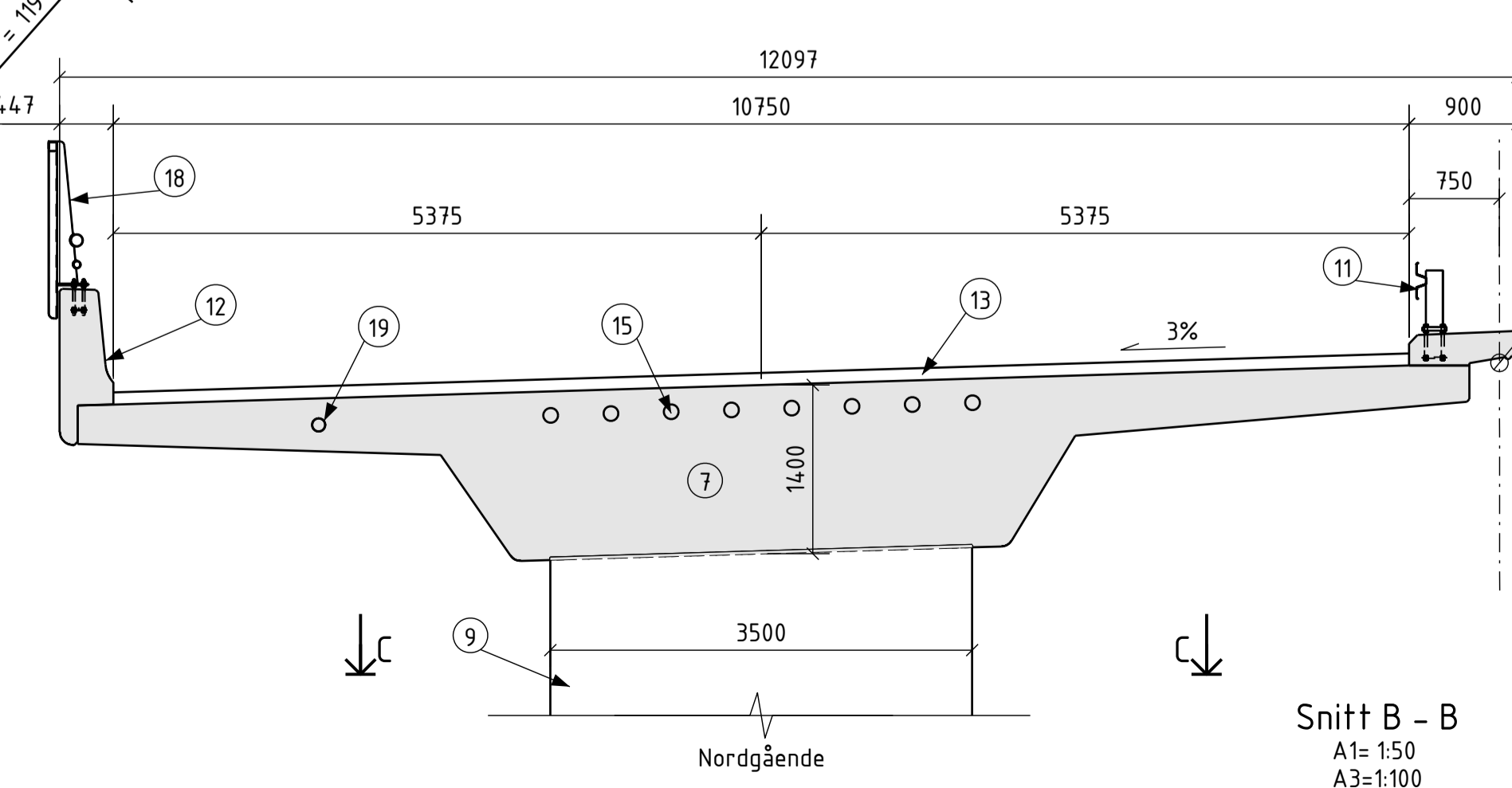
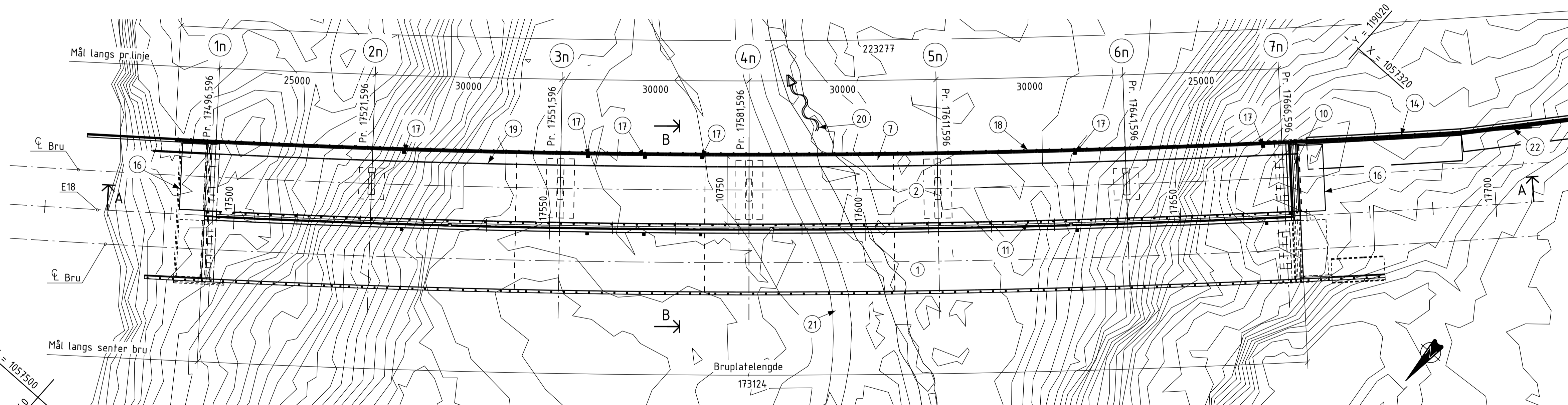
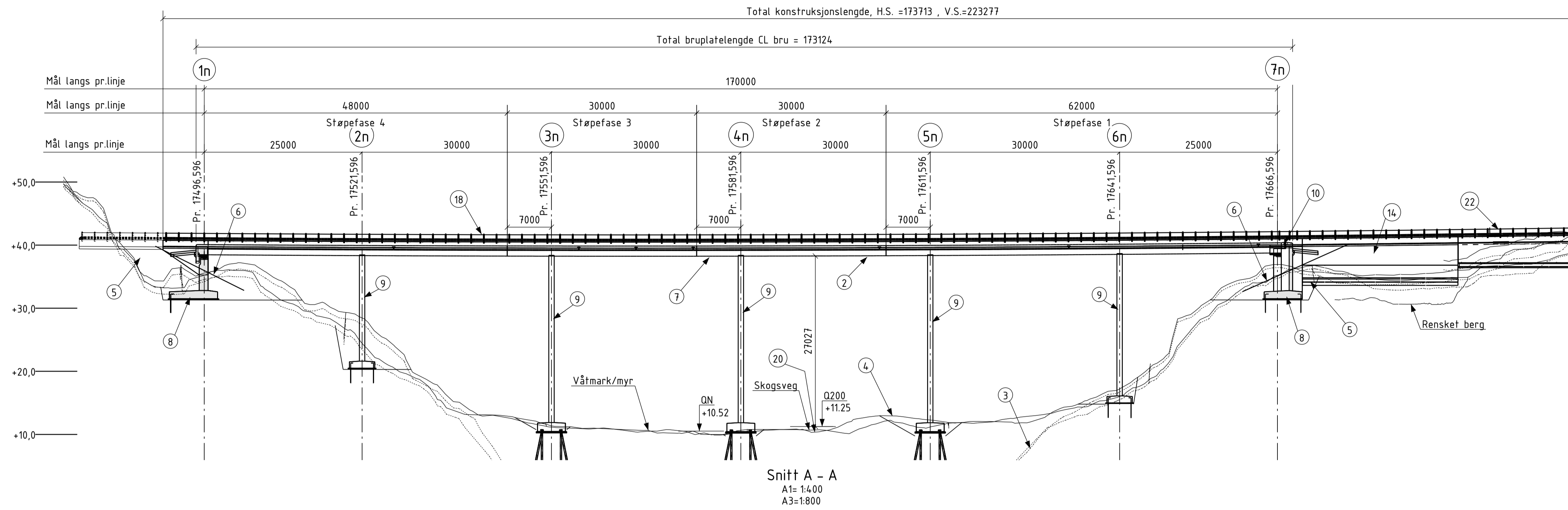

Merk: All målsetting er vist vertikalt eller horisontalt, såfremt ikke annet fremgår av tegningen.

**Merknader:**

- Generelt:**
  - Veg på bru: E18 Vegklasse H8, ÅDT < 20000, fartsgrense 110km/t
  - Veg under bru: Skogsbilveg/traktorveg
  - Bruoverbygning: Plasttøpt spennarmert 6-spenns bjelkebru med fastlager i akse 1 og fugelandkar i akse 7. Alle søyler har monolitisk forb. til overbygning
  - Føringsbredde: 10,75 m
  - Brulengde: 170,0 m lakseavstand i plan, antall spenn: 6
  - Koordinatsystem: NTM sone 8, NN2000
  - Ferdigstilt år: 2019
- Prosjekteringsgrunnlag:**
  - Brusprosjektering, håndbok N400 (2015 + NA-rundskriv 2016/12)
  - NS-EN Eurokode standarder
  - Prosesskode 2, håndbok R762 (2015)
- Prosjekterings- og utførelsesklasser**
  - Pålitelighetsklasse: 3 iht. NS-EN 1990:2002+A1:2005+NA:2016 [tab.NA.A1(901)]
  - Kontrollklasse: Utførelse (U) iht. NS-EN 1990:2002+A1:2005+NA:2016 (NA.A1.3.1)
  - Utførelsesklasse, betong: 3 iht. NS-EN 13670:2009+NA:2010
- Slitelag og fuktisolering**
  - Fuktisoleringssystem A3-4 iht. håndbok R762 (Prosesskode 2)
  - Bindlag Ab og slitelag Ska 16 iht. kontrakt, fuktisolering og asfalt totalt 100 mm
  - Brua er dimensjonert for egenvekt av belegning = 3,5 kN/m<sup>2</sup>
- Konstruksjonsmaterialer**
  - Betong: B45 SV-Standard
  - Slakkarmering: B500NC (NS 3576-3)
  - Spennarmering: fpk/fp0,1k = 1860/1640 MPa
- Fundamentering**
  - Akse 1n, 2n, 6n og 7n: Direkte på berg, bergbolter benyttes
  - Akse 3n, 4n, 5n: Stålkjernerpeler til berg
- Lager/ fuger**
  - Lager i akse 1n er fast i lengderetning
  - Monolitisk forb. til overbygning i akse 2n til 6n
  - I akse 7 er det glidelagre og fingerfuge
- Rekkverk**
  - Betongrekkverk

**Tegnforklaringer:**

- Røydalen bru, sørgående
- Røydalen bru, nordgående
- Antatt berg
- Eksisterende terreng
- Fylling med sprengstein
- Fremtidig terreng
- Plasttøpt bruoverbygning, 4 støpefaser
- Plasttøpt landkarkonstruksjon
- Plasttøpt søyle
- Dialatsjonsfuge, fugekonstruksjon i vegbane
- H1 rekkverk, STP - 11M/2
- Betongrekkverk
- Membran (12-3mm) + asfalt, totalt 100mm
- Støttemur
- Spennkabler
- Overgangsplate
- Vannavløp/sluk
- Støyskjerm
- Trekkerør
- Bekk, se tegn. K422-003 (Strømningsret. mot sør)
- Skogsveg / traktorveg
- Godkjent rekkverksovergang (Typegodkjent av Vegdirektoratet)

**Henvisninger:**

- K422-002 Grave-, sprengnings- og tilbakefyllingsplan, akse 1 til 4
- K422-003 Grave-, sprengnings- og tilbakefyllingsplan, akse 4 til 7
- K422-010 Landkar akse 1. Fundamentplan og snitt
- K422-011 Landkar akse 1. Oppriss
- K422-012 Landkar akse 1. Plan
- K422-070 Fugelandkar akse 7. Plan og snitt
- K422-071 Fugelandkar akse 7. Oppriss
- K423-020 Fundament og søyle, akse 2n og 6n
- K423-030 Fundament og søyle, akse 3n
- K423-040 Fundament og søyle, akse 4n
- K423-050 Fundament og søyle, akse 5n
- K423-101 Bruoverbygning, Akse 1 til 2
- K423-102 Bruoverbygning, Akse 2 til 3
- K423-103 Bruoverbygning, Akse 3 til 4
- K423-104 Bruoverbygning, Akse 4 til 5
- K423-105 Bruoverbygning, Akse 5 til 6
- K423-106 Bruoverbygning, Akse 6 til 7
- K423-110 Bruoverbygning, Brutversnitt
- K423-120 Bruoverbygning, Snitt og detaljer
- K423-130 Bruoverbygning, Vingemur akse 7n
- K423-150 Rekkverk
- K423-160 Lagre og fuge
- K423-161 Fuge, Detaljer
- K423-170 Belegning
- K423-190 Inspeksjon, drift og vedlikehold
- K423-201 Spennkabler, Kabelføring
- K423-202 Spennkabler, Detaljer

Som utført		KV	HENK	JASAT	
Revisjon	Revisjonen gjelder	Utarb.	Kontr.	Godkj.	Rev dato
Godkjent som arbeidstegning ifølge notat fra Vegdirektoratet					
Uttørt av:		Arkivref. 15/206272-26	2017-05-09		
NyeVeier		Tegningsdate	2019-03-15		
Bestiller		-			
Produsert for		Nye Veier			
Prosjektnummer		404			
Arkivreferanse		-			
Byggersnummer		09-2637			
Koordinatsystem		Euref89 NTM sone 8			
Oversiktstegning		NN2000			
Målestokk A1		1:50 1:400			
Målv målestokk A3		-			
Som utført		-			
Utarbeidet av	Kontrollert av	Godkjent av	Konsulentarkiv	Tegningsnummer / revisjonsbokstav	
KV	HENK	JASAT	5168070	K423-001	



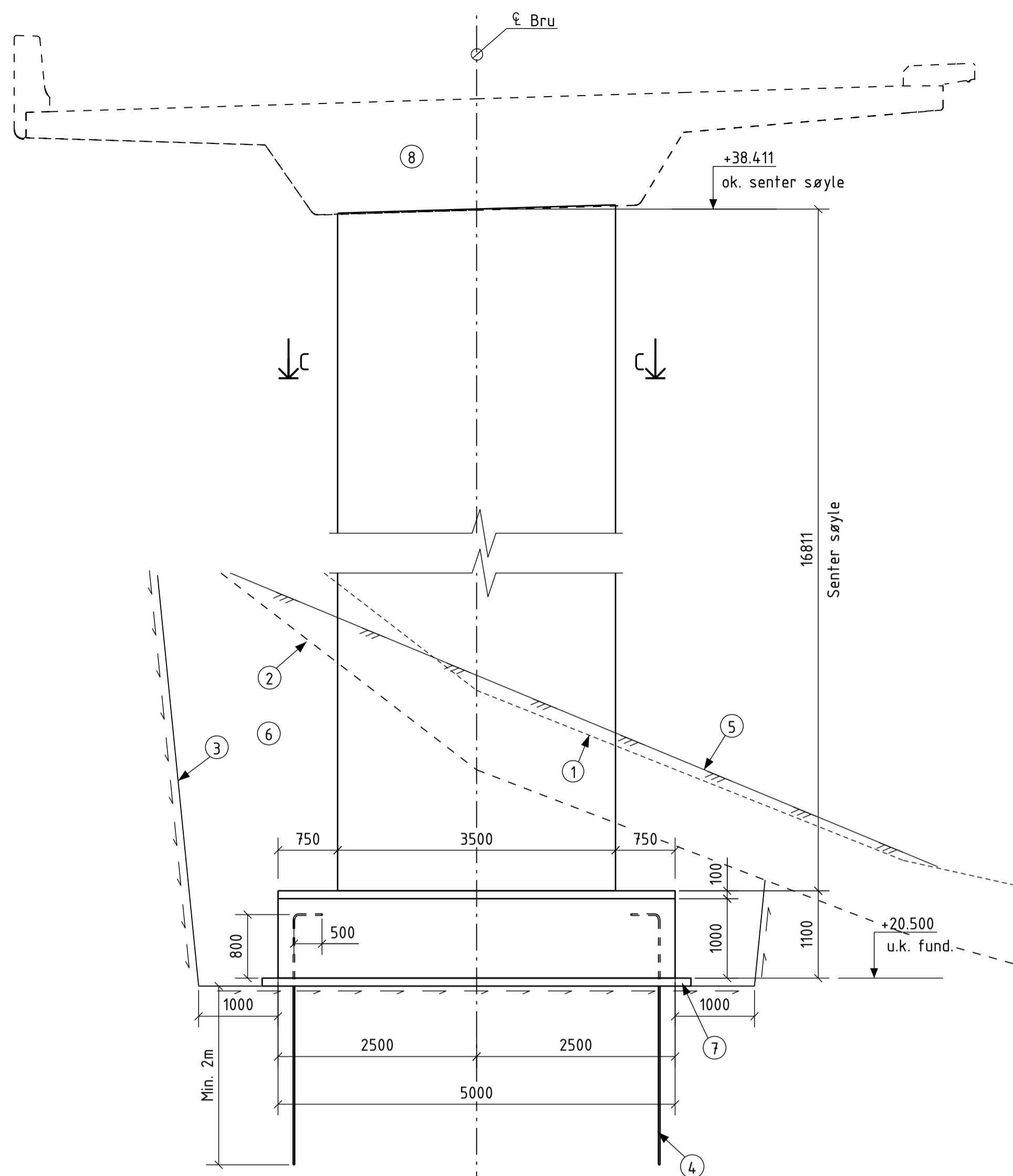

Oppriss A - A  
A1= 1:50  
A3=1:100

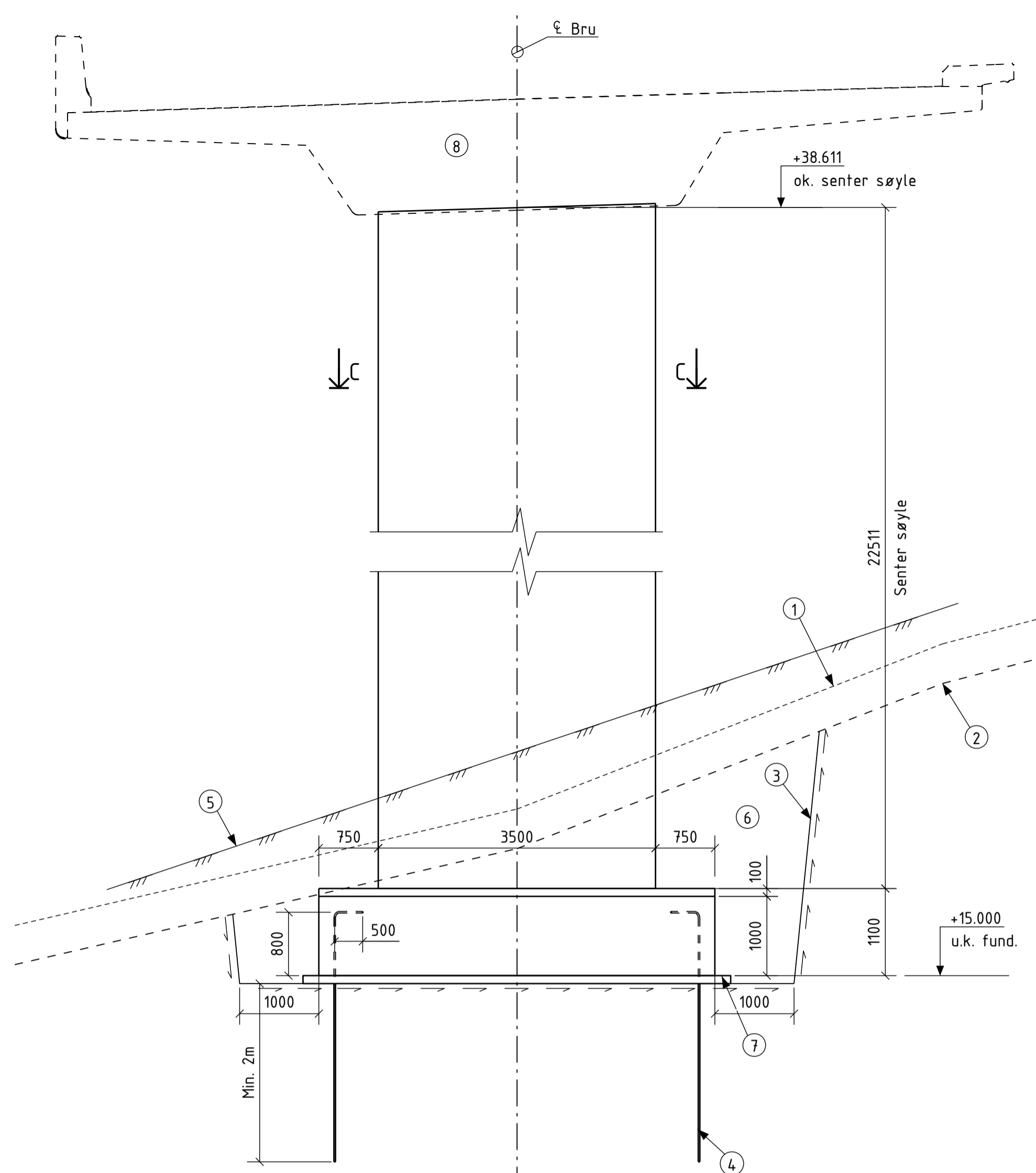

Oppriss D - D  
A1= 1:50  
A3=1:100

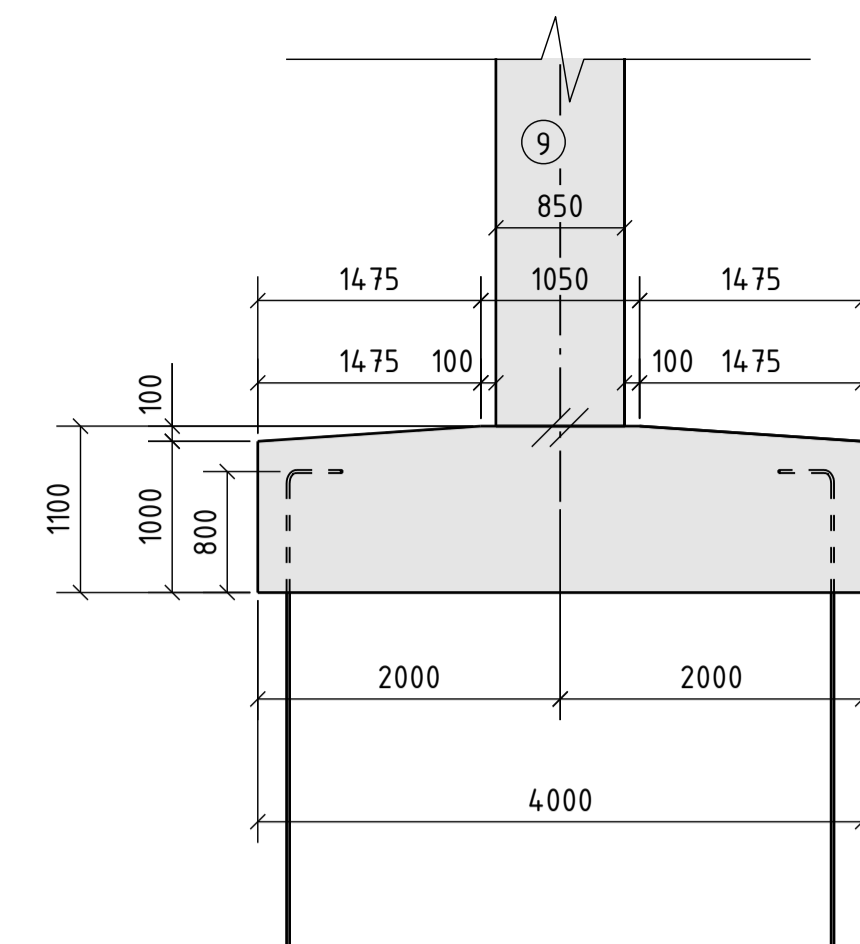

Snitt B - B  
A1= 1:50  
A3=1:100

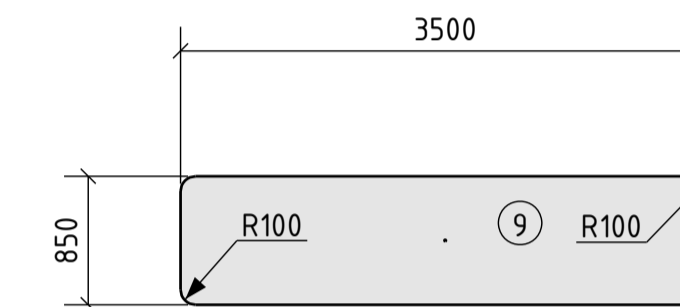

Snitt C - C  
A1= 1:50  
A3=1:100

KOORDINATBESTEMTE PUNKTER:

PUNKT	X	Y
N2.1	1 057 440,256	119 119,754
N2.2	1 057 442,805	119 122,837
N2.3	1 057 438,951	119 126,023
N2.4	1 057 436,402	119 122,940

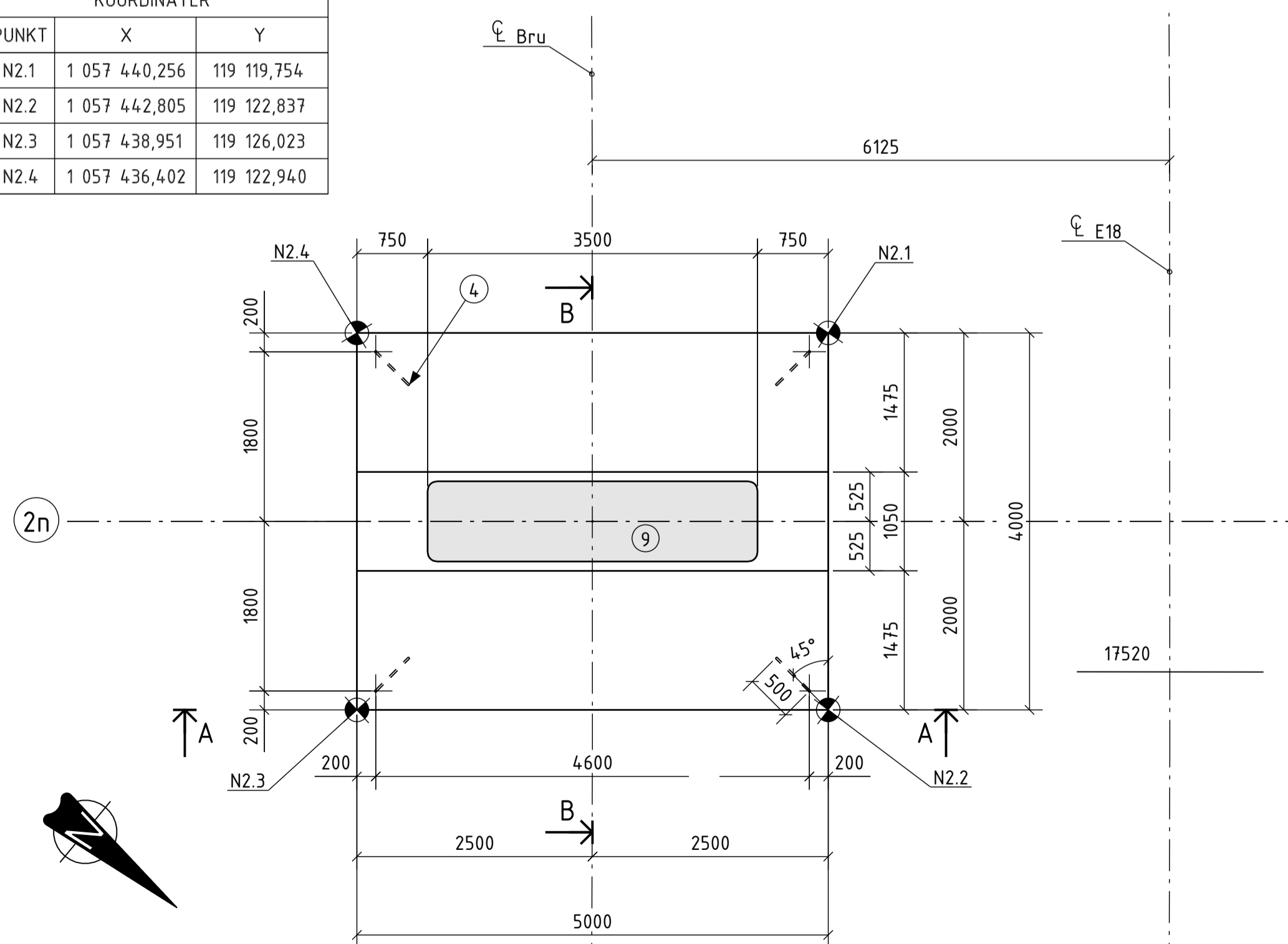

Plan akse 2n  
A1= 1:50  
A3=1:100

KOORDINATBESTEMTE PUNKTER:

PUNKT	X	Y
N6.1	1 057 360,839	119 030,146
N6.2	1 057 363,587	119 033,052
N6.3	1 057 359,954	119 036,488
N6.4	1 057 357,206	119 033,581

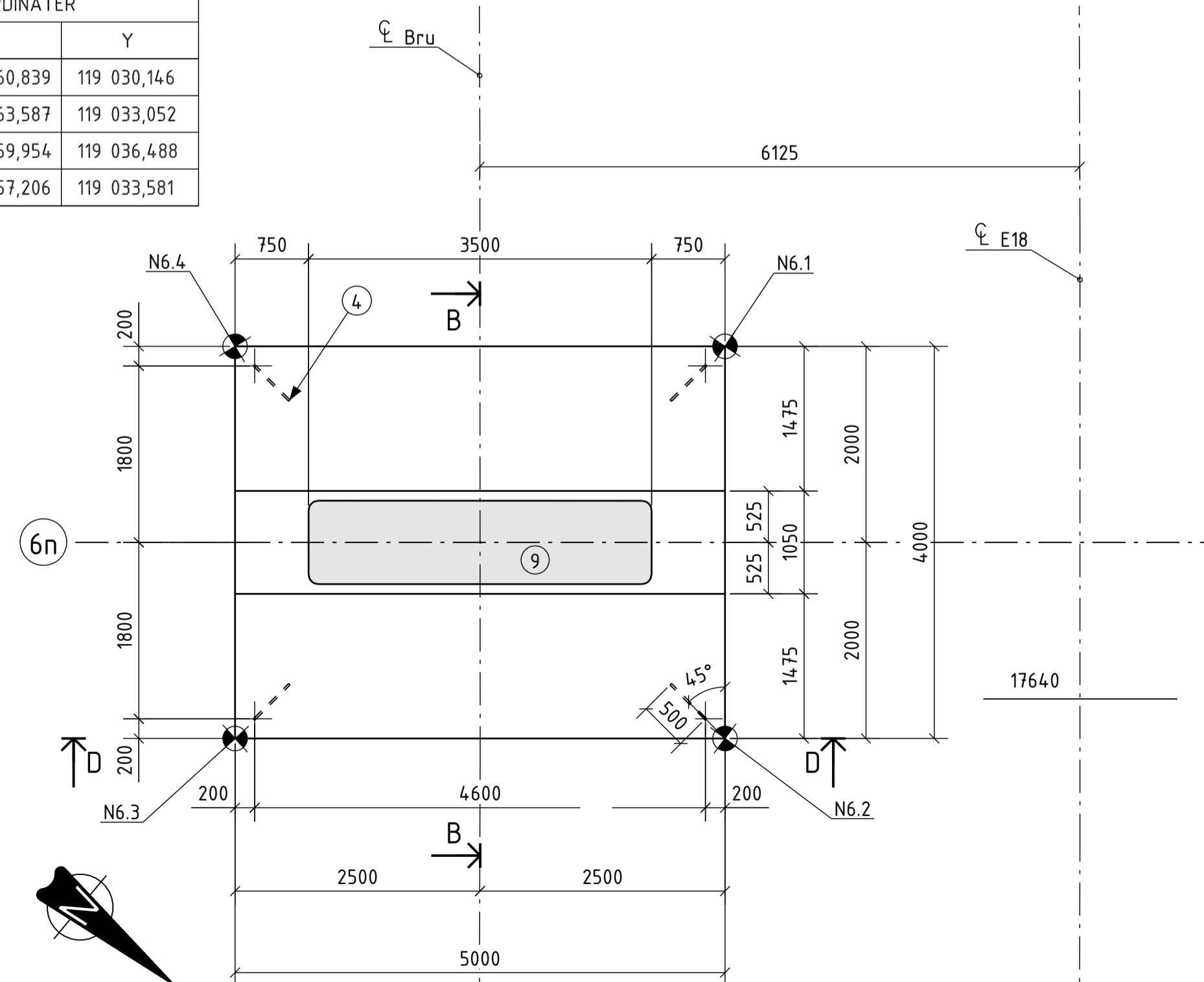

Plan akse 6n  
A1= 1:50  
A3=1:100

Merknader:

1. Konstruksjonsmaterialer, betong

- Materialkvalitet: B4.5, SV-Standard
- Betong: B500NC (NS 3576-3)
- Slakkammering: MF40
- Bestandighetsklasse: MFA0
- Tilslag: Dmaks=22 mm
- Luffinnhold: 4,5 +/- 1,5%
- Luffinnhold betongrekkverk: 5,5 +/- 1,5%
- Overdekning: iht. håndbok N400 (2015 + NA - Rundskriv 2016/12) iht. armeringstegninger)
- Synlige skarpe hjørner avfases 20x20 mm dersom annet ikke er angitt

2. Prosjekterings- og utførelsesklasser

- Pålitelighetsklasse: 3 iht. NS-EN 1990:2002+A1:2005+NA:2016 [fab.NA.A1(901)]
- Kontrollklasse: Utvidet (U) iht. NS-EN 1990:2002+A1:2005+NA:2016 (NA.A1.3.1)
- Utførelsesklasse, betong: 3 iht. NS-EN 13670:2009+NA:2010

Merk: All målsetting er vist vertikalt eller horisontalt, såfremt ikke annet fremgår av tegningen.

Tegnforklaringer:

- 1 Eksisterende terreng
- 2 Antatt berg
- 3 Teoretisk sprengningsprofil
- 4 Varmforsinkede bergbolter  $\varnothing$ 20 gyses min. 2m inn i fast berg, gyses fast med Rescon Zinkbolt el. tilsv. det benyttes bolter med sfålkvalitet B500C iht. NS 3576-3. boltene skal varmforsinkes minst 65 um iht. NS-EN ISO 1461 og pulverlakeres med epoksy med minimum tykkelse 60 um iht. N400 pkt. 11.6.4.3 prosess 23.2
- 5 O.K. fremtidig terreng
- 6 Tilbakefylte masser. Se tegn. K422-002 og -003
- 7 Betongavretting/understøp med konstruksjonsbetong B4.5. Min. avrettingslag 100mm, ved behov for økt tykkelse se merknad nr. 1 Sprenging på tegn. K422-002
- 8 Bruoverbygning
- 9 Betongsøyle

Henvisninger:

- K423-001 Oversiktstegning
- K422-002 Grave-, sprengnings- og tilbakefyllingsplan, akse 1 til 4

Som utført		KV	HENK	JASAT	
Revisjon	Utarbeidet	Utarb.	Kontr.	Godkj.	Rev dato
Godkjent som arbeidstegning ifølge notat fra Vegdirektoratet					
Tegningsdato		2019-03-15		2017-05-09	
Bestiller		Nye Veier		-	
Prosjektnummer		404		-	
Arkivreferanse		-		-	
Byggersnummer		09-2637		-	
Koordinatsystem		Euref89 NTM sone 8		-	
Høydesystem		NN2000		-	
Målestokk A1		1:50		-	
Målestokk A3		1:100		-	
Som utført		-		-	
Utarbeidet av	Kontrollert av	Godkjent av	Konsulentarkiv	Tegningsnummer / revisjonsbokstav	
KV	HENK	JASAT	5168070	K423-020	

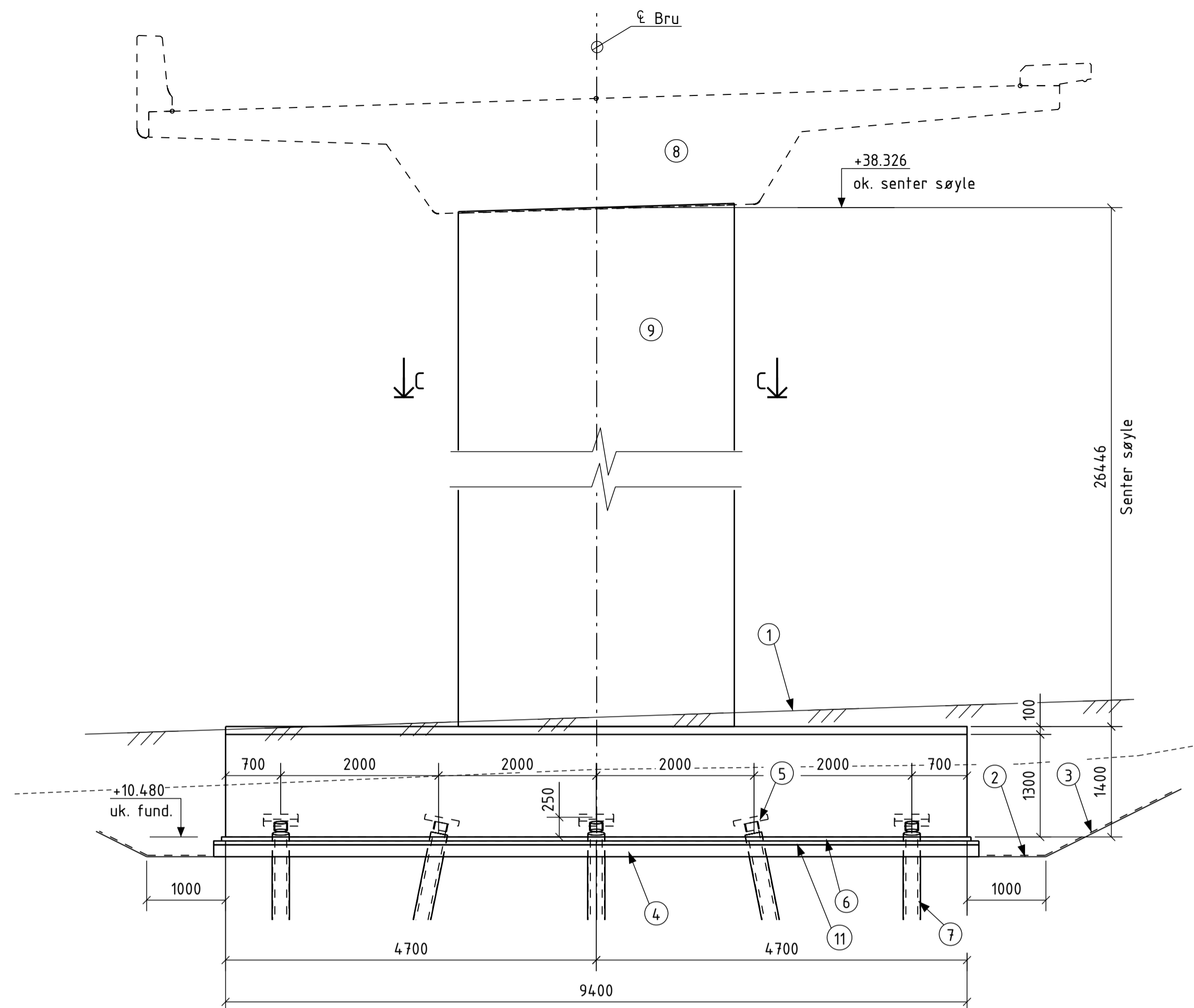

Oppriss A - A  
A1=1:50  
A3=1:100

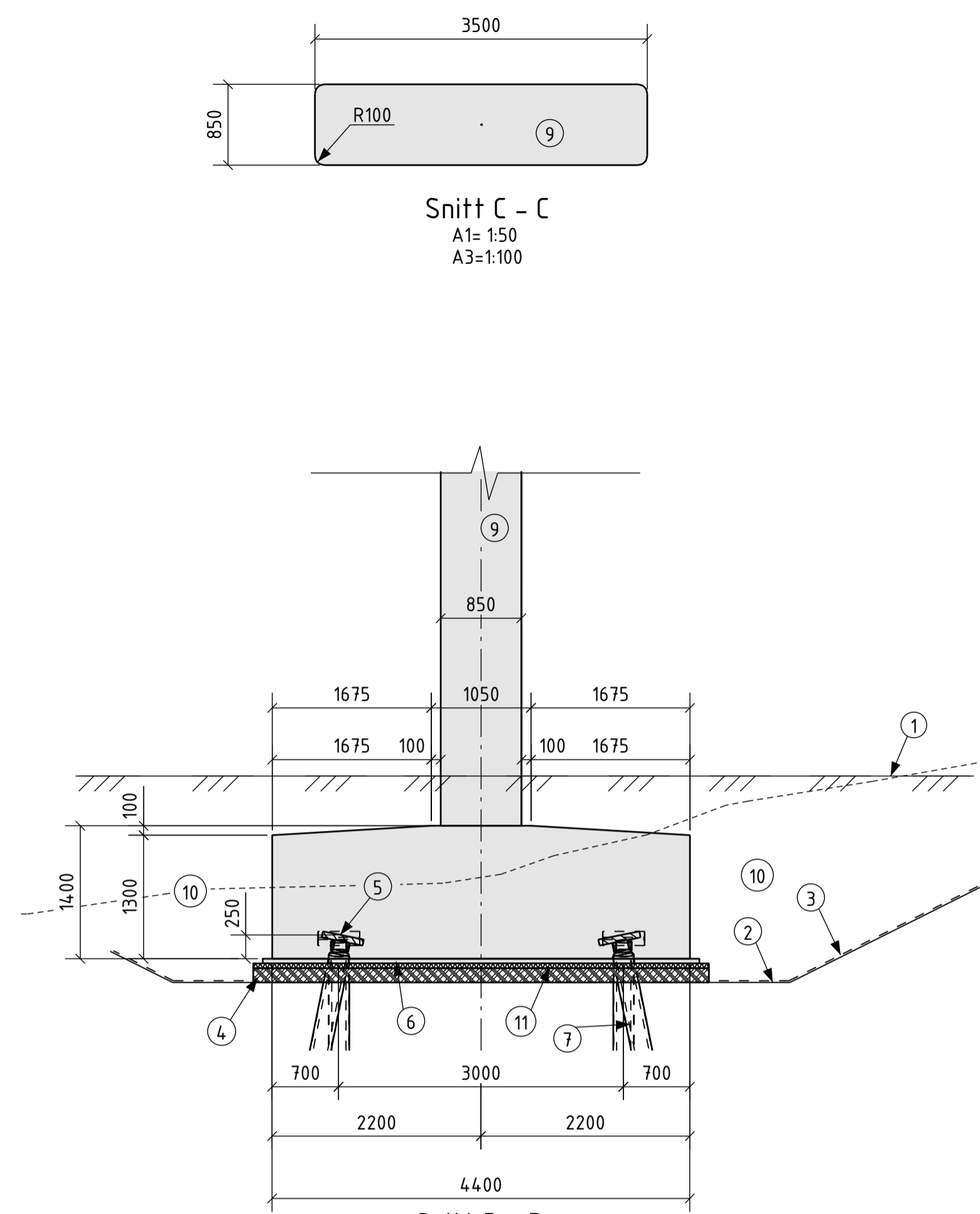

Snitt C - C  
A1=1:50  
A3=1:100

Snitt B - B  
A1=1:50  
A3=1:100

KOORDINATBESTEMTE PUNKTER:

KOORDINATER		
PUNKT	X	Y
N3.1	1 057 422,507	119 095,277
N3.2	1 057 425,366	119 098,621
N3.3	1 057 418,222	119 104,730
N3.4	1 057 415,362	119 101,386

PROSJEKTERTE PUNKTER PEL U.K. FUNDAMENT:

KOORDINATER				
PEL	X	Y	HELN.	R.VINKEL, α
N301	1 057 418,299	119 103,743	5:1	310,531
N302	1 057 419,819	119 102,443	5:1	220,531
N303	1 057 421,339	119 101,144	5:1	310,531
N304	1 057 422,859	119 099,844	5:1	40,531
N305	1 057 424,379	119 098,544	5:1	310,531
N306	1 057 416,349	119 101,463	5:1	130,531
N307	1 057 417,869	119 100,163	5:1	220,531
N308	1 057 419,389	119 098,863	5:1	130,531
N309	1 057 420,910	119 097,564	5:1	40,531
N310	1 057 422,430	119 096,264	5:1	130,531

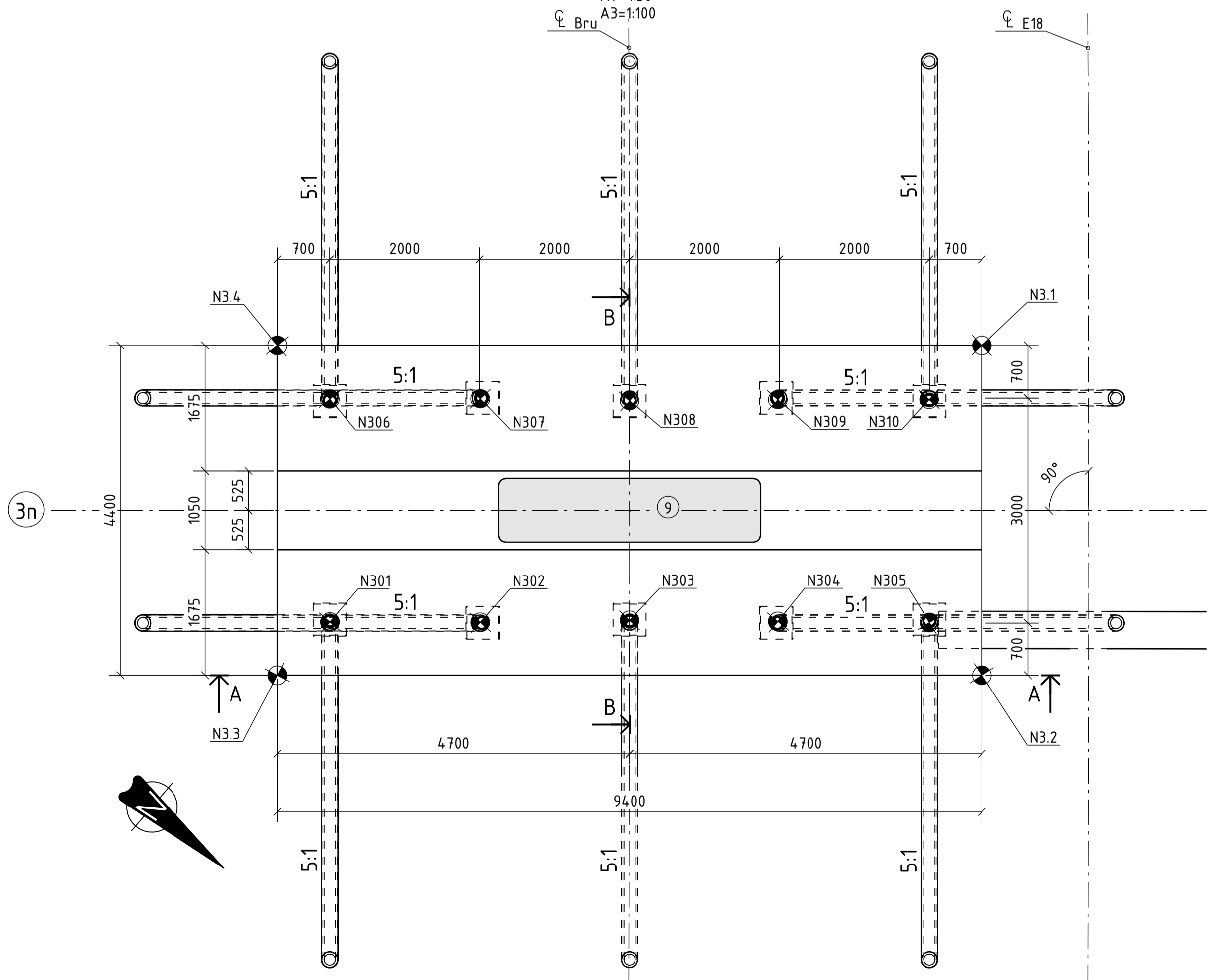
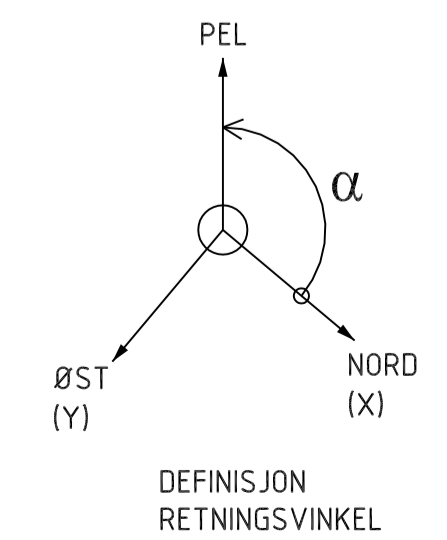

Plan akse 3n  
A1=1:50  
A3=1:100

Merknader:

- 1. Konstruksjonsmaterialer, betong**
- Materialkvalitet: B4.5, SV-Standard
  - Betong: B500NC (NS 3576-3)
  - Slakkarmering: MF40
  - Bestandighetsklasse: Dmaks=22 mm
  - Tilslag: 4,5 +/- 1,5%
  - Luffinnhold: 5,5 +/- 1,5%
  - Luffinnhold betongrekkverk: iht. håndbok N400 (2015 + NA - Rundskriv 2016/12) (se armeringstegninger)
  - Overdekning: 3 iht. NS-EN 13670:2009+NA:2010
  - Synlige skarpe hjørner avfases 20x20 mm dersom annet ikke er angitt

**2. Prosjekterings- og utførelsesklasser**

- Pålitelighetsklasse: 3 iht. NS-EN 1990:2002+A1:2005+NA:2016 [fab.NA.A1(901)]
- Kontrollklasse: Utfvidet (U) iht. NS-EN 1990:2002+A1:2005+NA:2016 (NA.A1.3.1)
- Utførelsesklasse, betong: 3 iht. NS-EN 13670:2009+NA:2010

**Merk:** All måssetting er vist vertikalt eller horisontalt, såfremt ikke annet fremgår av tegningen.

Tegnforklaringer:

- Nytt terrengnivå i ca. tilsvarende nivå som tidligere.
- Gravelinje. Se tegn. K422-002 og -003
- Fiberduk bruksklasse 4 etter NorGeoSpec
- Avrettingslag 150mm pukk 22-64mm
- Topplate 450x80x450mm
- Betongavretting 50mm B45
- Stålkjernepel ø150, bores min. 1500mm i fast berg
- Bruoverbygning
- Betongsøyle
- Tilbakefylte masser. Se tegn. K422-002 og -003
- Frostisolasjon 50 mm XPS med korttids trykkfasthet på min. 700 kPa.

Henvisninger:

- K422-002 Grave-, sprengnings- og tilbakefyllingsplan, akse 1 til 4
- K422-003 Grave-, sprengnings- og tilbakefyllingsplan, akse 4 til 7
- K423-001 Oversiktstegning

Som utført		KV	HENK	JASAT	
Revisjon	Revisjonen gjelder	Utarb.	Kontr.	Godkj.	Rev dato
Godkjent som arbeidstegning ifølge notat fra Vegdirektoratet					
Tegningsdato		Arkivref. 15/206272-26		2017-05-09	
Utarb. av: NyeVeier		Utarb. av: AF GRUPPEN		Tegningsdato: 2019-03-15	
Bestiller: -		Produsert for: Nye Veier		Prosjektnummer: 404	
E18 Tvedestrand - Arendal		Arkivreferanse: -		Byggersnummer: 09-2637	
04 Sagene - Piletjenn		Koordinatsystem: Euref89 NTM sone 8		Høydesystem: NN2000	
K423 Røydalen bru, nordgående		Målestokk A1		Målestokk A3	
Pelefundament og søyle, akse 3n		Som utført		Tegningsnummer / revisjonsbokstav: K423-030	
Utarbeidet av	Kontrollert av	Godkjent av	Konsulentarkiv	Tegningsnummer / revisjonsbokstav	
KV	HENK	JASAT	5168070	K423-030	

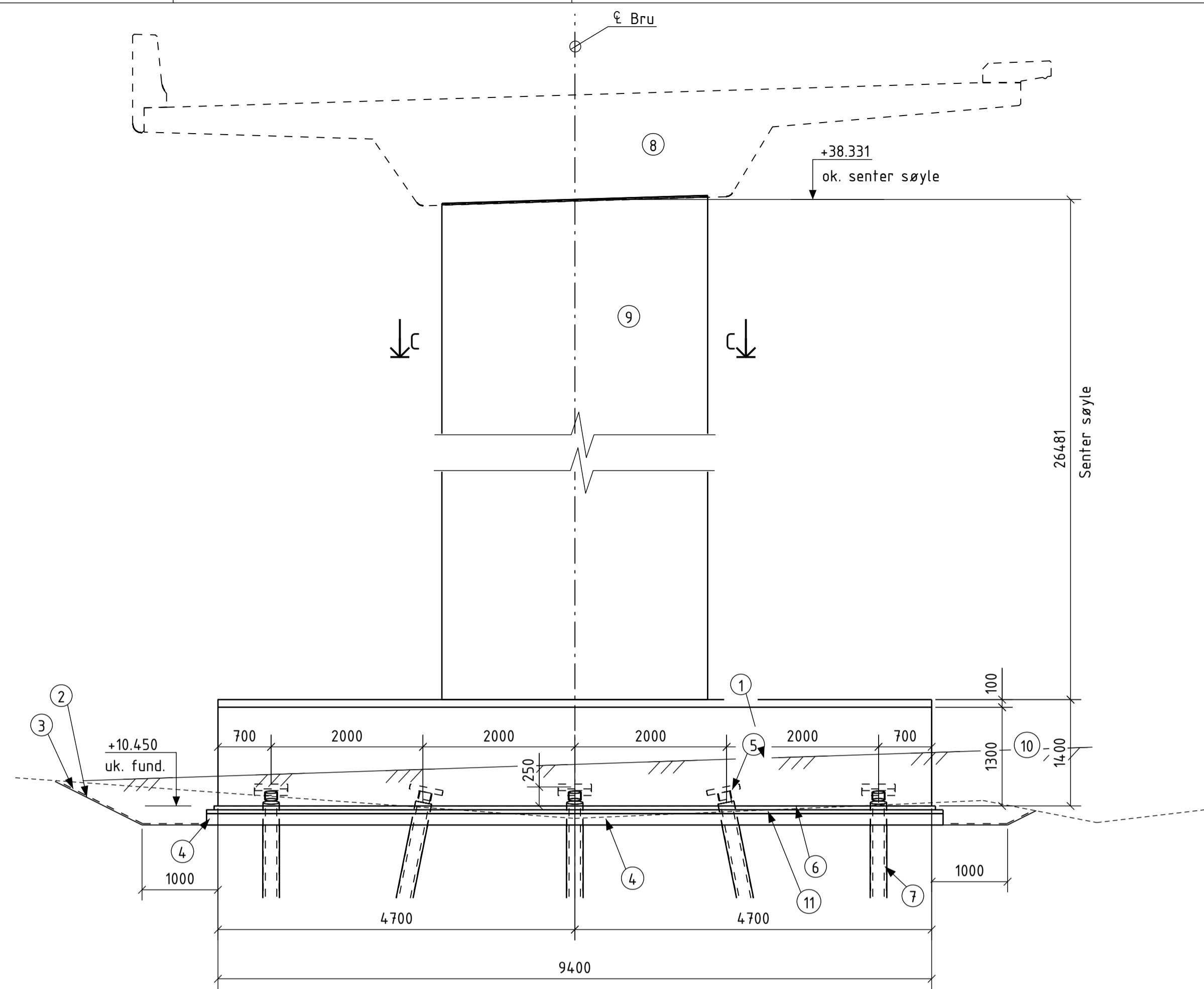

Oppliss A - A  
A1= 1:50  
A3=1:100

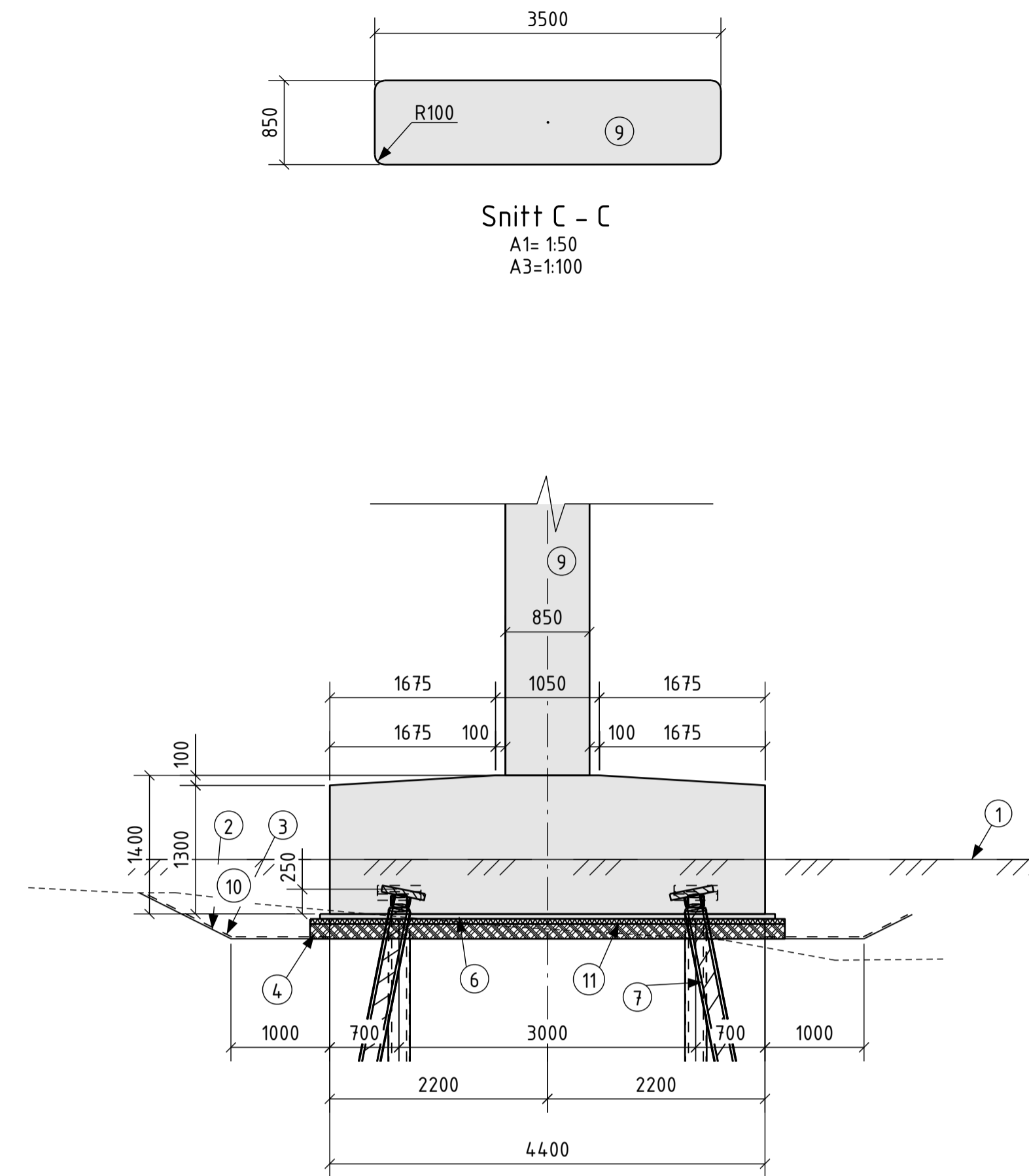

Snitt C - C  
A1= 1:50  
A3=1:100

Snitt B - B  
A1= 1:50  
A3=1:100

KOORDINATBESTEMTE PUNKTER:

KOORDINATER		
PUNKT	X	Y
N4.1	1 057 402,810	119 072,681
N4.2	1 057 405,725	119 075,977
N4.3	1 057 398,683	119 082,204
N4.4	1 057 395,768	119 078,908

PROSJEKTERTE PUNKTER PEL U.K. FUNDAMENT:

KOORDINATER				
PEL	X	Y	HELN.	R.VINKEL, $\alpha$
N401	1 057 398,744	119 081,216	5:1	311,486
N402	1 057 400,242	119 079,891	5:1	221,486
N403	1 057 401,740	119 078,566	5:1	311,486
N404	1 057 403,238	119 077,241	5:1	41,486
N405	1 057 404,736	119 075,916	5:1	311,486
N406	1 057 396,756	119 078,969	5:1	131,486
N407	1 057 398,254	119 077,644	5:1	221,486
N408	1 057 399,753	119 076,319	5:1	131,486
N409	1 057 401,251	119 074,994	5:1	41,486
N410	1 057 402,749	119 073,669	5:1	131,486

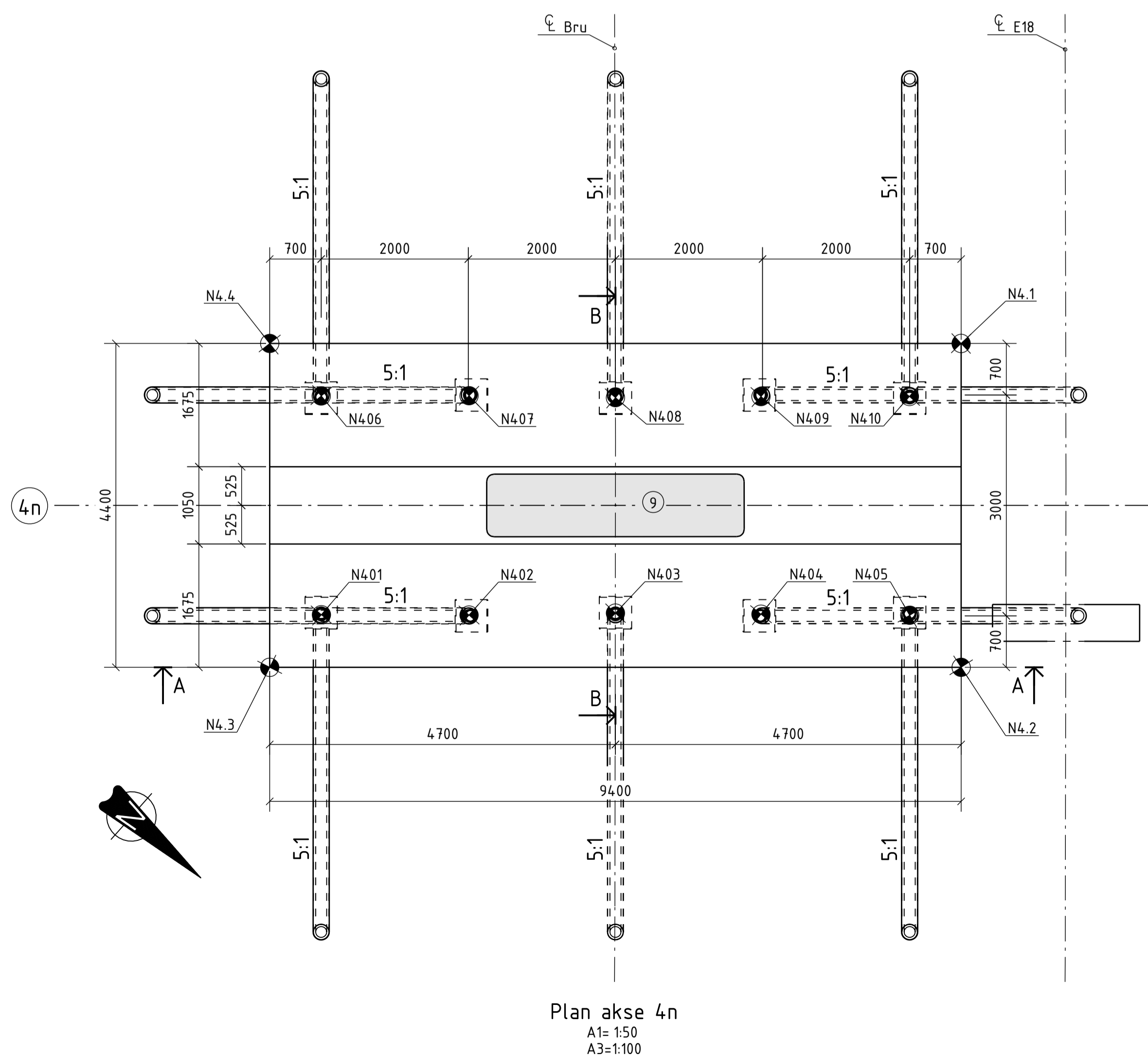
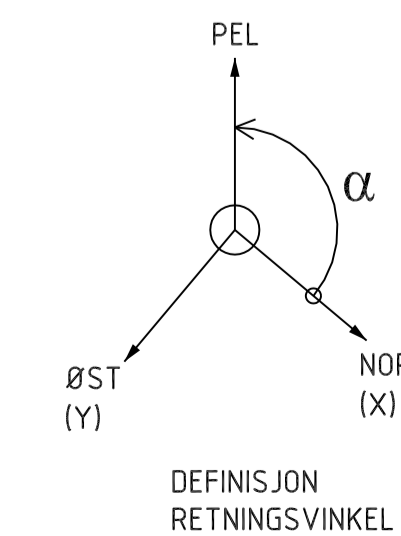

Plan akse 4n  
A1= 1:50  
A3=1:100

Merknader:

1. Konstruksjonsmaterialer, betong

- Materialkvalitet
- Betong: B45, SV-Standard
- Slakkarmering: B500NC (NS 3576-3)
- Bestandighetsklasse: MF40
- Tilslag: Dmaks=22 mm
- Luffinnhold: 4,5 +/- 1,5%
- Luffinnhold betongrekkverk: 5,5 +/- 1,5%
- Overdekning: iht. håndbok N400 (2015 + NA - Rundskriv 2016/12) (se armeringstegninger)
- Synlige skarpe hjørner avfases 20x20 mm dersom annet ikke er angitt

2. Prosjekterings- og utførelsesklasser

- Pålitelighetsklasse: 3 iht. NS-EN 1990:2002+A1:2005+NA:2016 [fab.NA.A1(901)]
- Kontrollklasse: Utfvidet (U) iht. NS-EN 1990:2002+A1:2005+NA:2016 (NA.A1.3.1)
- Utførelsesklasse, betong: 3 iht. NS-EN 13670:2009+NA:2010

Merk: All måtsetting er vist vertikalt eller horisontalt, såfremt ikke annet fremgår av tegningen.

Tegnforklaringer:

- Nytt terrengnivå i ca. tilsvarende nivå som tidligere.
- Gravelinje. Se tegn. K422-002 og -003
- Fiberduk bruksklasse 4 etter NorGeoSpec
- Avrettingslag 150mm pukk 22-64mm
- Topplate 450x80x450mm
- Betongavretting 50mm B45
- Stålkjernepel ø150, bores min. 1500mm i fast berg
- Bruoverbygning
- Betongsøyle
- Tilbakefylte masser. Se tegn. K422-002 og -003
- Frostisolasjon 50 mm XPS med korttids trykkfasthet på min. 700 kPa.

Henvisninger:

- K422-002 Grave-, sprengnings- og tilbakefyllingsplan, akse 1 til 4
- K422-003 Grave-, sprengnings- og tilbakefyllingsplan, akse 4 til 7
- K423-001 Oversiktstegning

Som utført		KV	HENK	JASAT	
Revisjon	Revisjonen gjelder	Utarb.	Kontr.	Godkj.	Rev dato
Godkjent som arbeidstegning ifølge notat fra Vegdirektoratet		Arkivref. 15/206272-26	2017-05-09		
Utført av: <b>NyeVeier</b>		Tegningsdate	2019-03-15		
		Bestiller	-		
		Produsert for	Nye Veier		
		Prosjektnummer	404		
E18 Tvedestrand - Arendal		Arkivreferanse			
04 Sagene - Piletjenn		Byggersnummer	09-2637		
K423 Røydalen bru, nordgående		Koordinatsystem	Euref89 NTM sone 8		
Pelefundament og søyle, akse 4n		Høydesystem	NN2000		
		Målestokk A1	1:50		
		Målv målestokk A3			
Som utført		Utarbeidet av	Kontrollert av	Godkjent av	Konsulentarkiv
		KV	HENK	JASAT	5168070
		Tegningsnummer / revisjonsbokstav	K423-040		

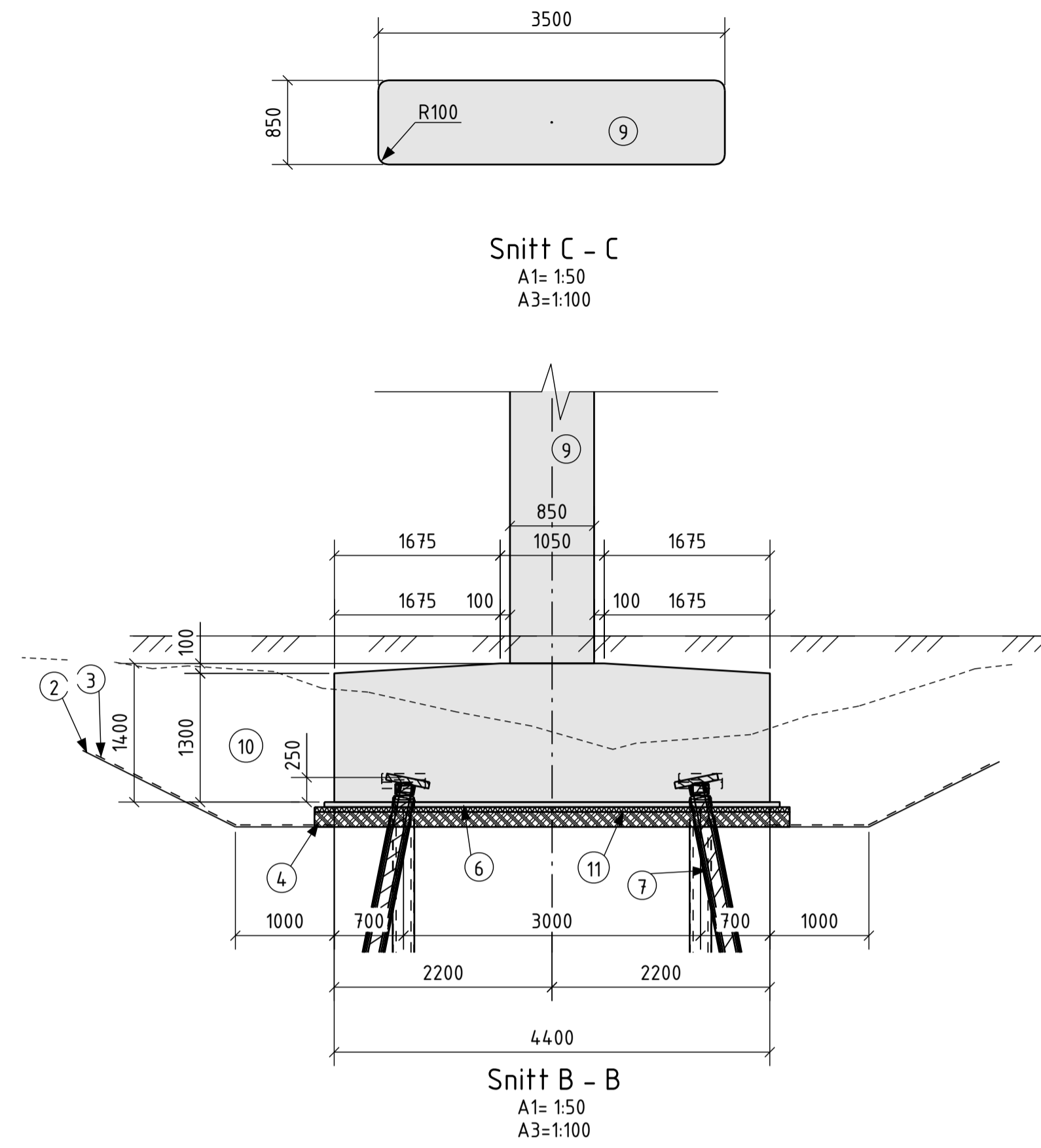
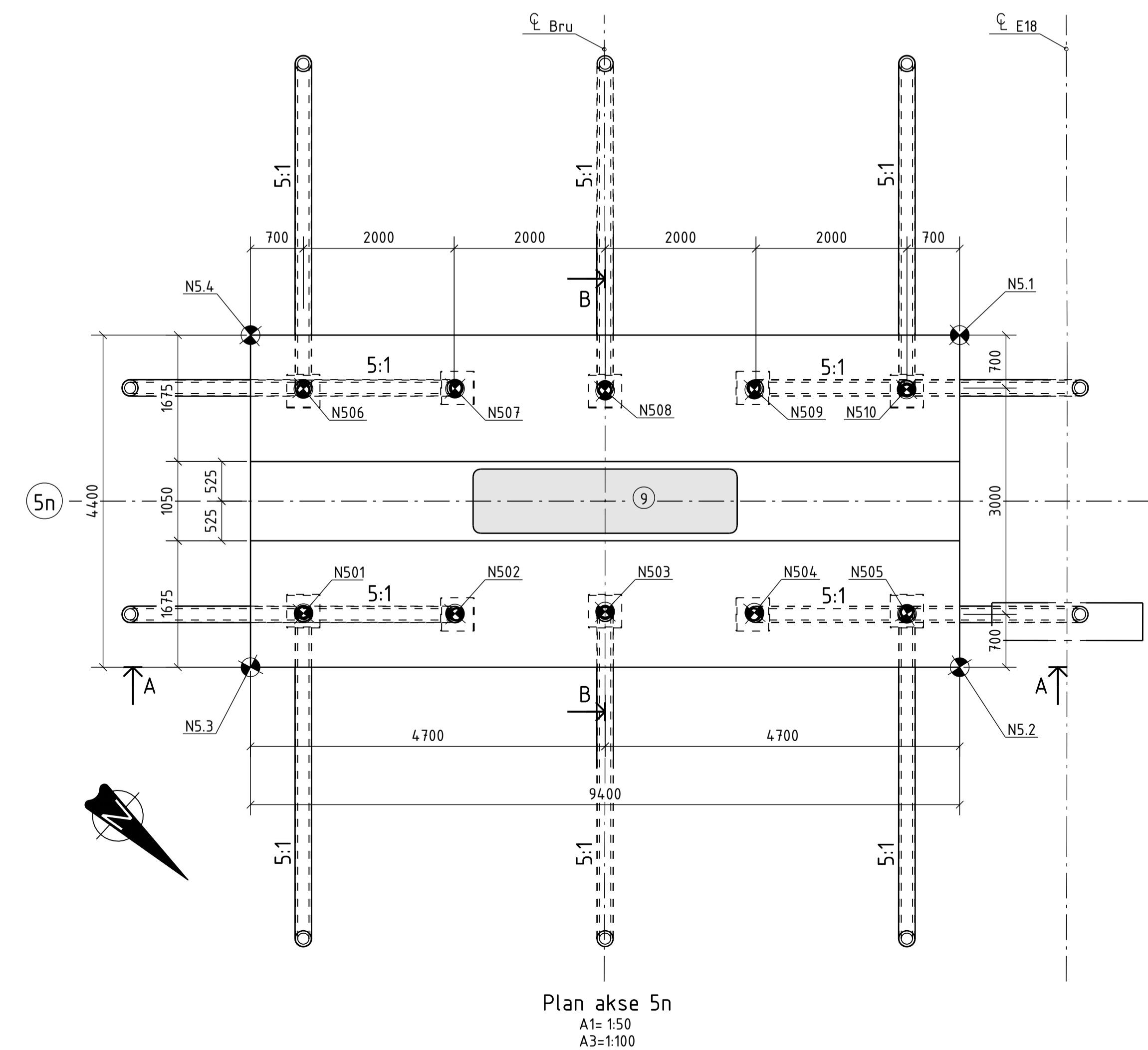
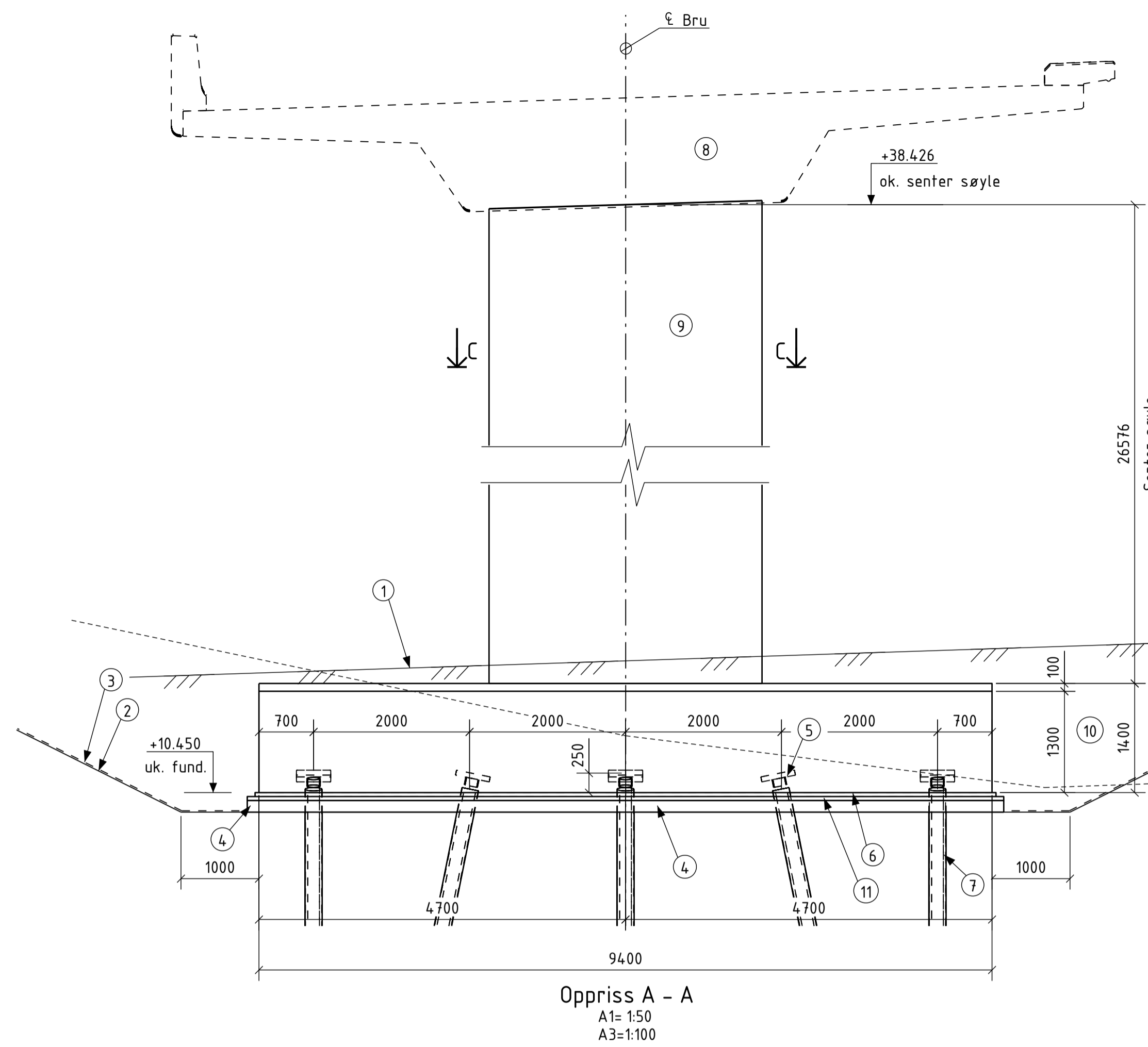

KOORDINATBESTEMTE PUNKTER:

KOORDINATER		
PUNKT	X	Y
N5.1	1 057 382,739	119 050,416
N5.2	1 057 385,708	119 053,663
N5.3	1 057 378,771	119 060,007
N5.4	1 057 375,802	119 056,760

PROSJEKTERTE PUNKTER PEL U.K. FUNDAMENT:

KOORDINATER				
PEL	X	Y	HELN.	R.VINKEL, α
N501	1 057 378,815	119 059,018	5:1	312,441
N502	1 057 380,291	119 057,668	5:1	222,441
N503	1 057 381,767	119 056,318	5:1	312,441
N504	1 057 383,243	119 054,969	5:1	42,441
N505	1 057 384,719	119 053,619	5:1	312,441
N506	1 057 376,791	119 056,804	5:1	132,441
N507	1 057 378,267	119 055,454	5:1	222,441
N508	1 057 379,743	119 054,105	5:1	132,441
N509	1 057 381,219	119 052,755	5:1	42,441
N510	1 057 382,695	119 051,405	5:1	132,441

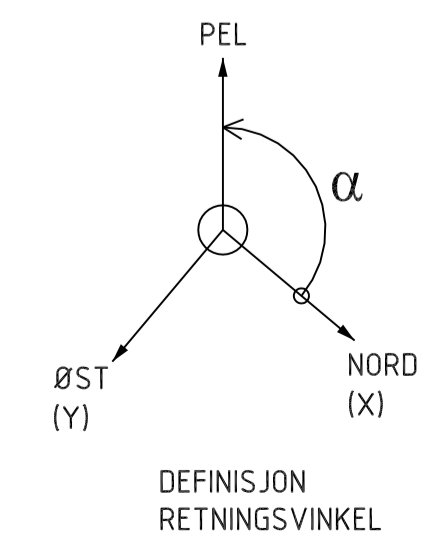

Merknader:

- 1. Konstruksjonsmaterialer, betong**
- Materialkvalitet: B45, SV-Standard
  - Betong: B500NC (NS 3576-3)
  - Slakkarmoring: MF40
  - Bestandighetsklasse: Dmaks=22 mm
  - Tilslag: 4,5 +/- 1,5%
  - Luffinnhold: 5,5 +/- 1,5%
  - Luffinnhold betongrekkverk: iht. håndbok N400 (2015 + NA - Rundskriv 2016/12)
  - Overdekning: (se armeringstegninger)
  - Synlige skarpe hjørner avfases 20x20 mm dersom annet ikke er angitt

**2. Prosjekterings- og utførelsesklasser**

- Pålitelighetsklasse: 3 iht. NS-EN 1990:2002+A1:2005+NA:2016 [fab.NA.A1(901)]
- Kontrollklasse: Utførelse (U) iht. NS-EN 1990:2002+A1:2005+NA:2016 (NA.A1.3.1)
- Utførelsesklasse, betong: 3 iht. NS-EN 13670:2009+NA:2010

**Merk:** All måtsetting er vist vertikalt eller horisontalt, såfremt ikke annet fremgår av tegningen.

Tegnforklaringer:

- 1) Nytt terrengnivå i ca. tilsvarende nivå som tidligere.
- 2) Gravelinje. Se tegn. K422-002 og -003
- 3) Fiberduk bruksklasse 4 etter NorGeoSpec
- 4) Avrettingslag 150mm pukk 22-64mm
- 5) Topplate 450x80x450mm
- 6) Betongavretting 50mm B45
- 7) Stålkjernepel ø150, bores min. 1500mm i fast berg
- 8) Bruoverbygning
- 9) Betongsøyle
- 10) Tilbakefylte masser. Se tegn. K422-002 og -003
- 11) Frostisolasjon 50 mm XPS med korttids trykkfasthet på min. 700 kPa.

Henvisninger:

- K422-002 Grave-, sprengnings- og tilbakefyllingsplan, akse 1 til 4
- K422-003 Grave-, sprengnings- og tilbakefyllingsplan, akse 4 til 7
- K423-001 Oversiktstegning

Som utført		KV	HENK	JASAT	
Revisjon	Revisjonen gjelder	Utarb.	Kontr.	Godkj.	Rev dato
Godkjent som arbeidstegning ifølge notat fra Vegdirektoratet		Arkivref. 15/206272-26			2017-05-09
Utført av: <b>NyeVeier</b>		Tegningsdate			2019-03-15
		Bestiller			-
		Produsert for			Nye Veier
		Prosjektnummer			404
E18 Tvedestrand - Arendal		Arkivreferanse			
04 Sagene - Piletjenn		Byggesaksnummer			09-2637
K423 Røydalen bru, nordgående		Koordinatsystem			Euref89 NTM sone 8
Pelefundament og søyle, akse 5n		Høydesystem			NN2000
Som utført		Målestokk A1			1:50
		Målestokk A3			
Utarbeidet av	Kontrollert av	Godkjent av	Konsulentarkiv	Tegningsnummer / revisjonsbokstav	K423-050
KV	HENK	JASAT	5168070		

**Merknader:**

**1. Betongkonstruksjoner**

- Materialkvalitet: B45, SV-Standard
- Betong: B500NC (NS 3576-3)
- Bestandighetsklasse: MF40
- Tilslag: Dmaks=22 mm
- Luftinnhold: 4,5 +/- 1,5%
- Luftinnhold betongrekkverk: 5,5 +/- 1,5%
- Overdekning: iht. håndbok N400 (2015 + NA - Rundskriv 2016/12) (se armeringstegninger)
- Nøyaktighetsklasse:
- Generelt: B iht. prosesskoden
- Kantbjelke/betongrekkverk: A iht. prosesskoden
- Synlige skarpe hjørner avfases 20x20 mm dersom annet ikke er angitt

**2. Prosjekterings- og utførelsesklasser**

- Pålitelighetsklasse: 3 iht. NS-EN 1990:2002+A1:2005+NA:2016 [fab.NA.A1(901)]
- Kontrollklasse: Utførelse (U) iht. NS-EN 1990:2002+A1:2005+NA:2016 (NA.A1.3.1)
- Utførelsesklasse, betong: 3 iht. NS-EN 13670:2009+NA:2010

Merk: All målsetting er vist vertikalt eller horisontalt, såfremt ikke annet fremgår av tegningen.

**Tegnforklaringer:**

- ① Betongrekkverk med innstøpte boltegrupper for støyskjerm. Se tegn.nr. K423-150
- ② Kjøresterkt lavt H2-rekkverk med innstøpte boltegrupper. Se tegn.nr. K423-150
- ③ For tilslutning belegning inntil kantbjelker og sluk, se tegn. K423-170
- ④ O.K. slitelag
- ⑤ Nivelleringsbolt. Se tegn. K423-120
- ⑥ Spennkabel. Se tegn. K423-201
- ⑦ Sluk
- ⑧ Betongsøyle, stikker 20mm opp i overbygning
- ⑨ Innstøpt pvc trekkerør, 1stk. Ø110mm, i brutverrsnitt. Se også tegn. K423-120

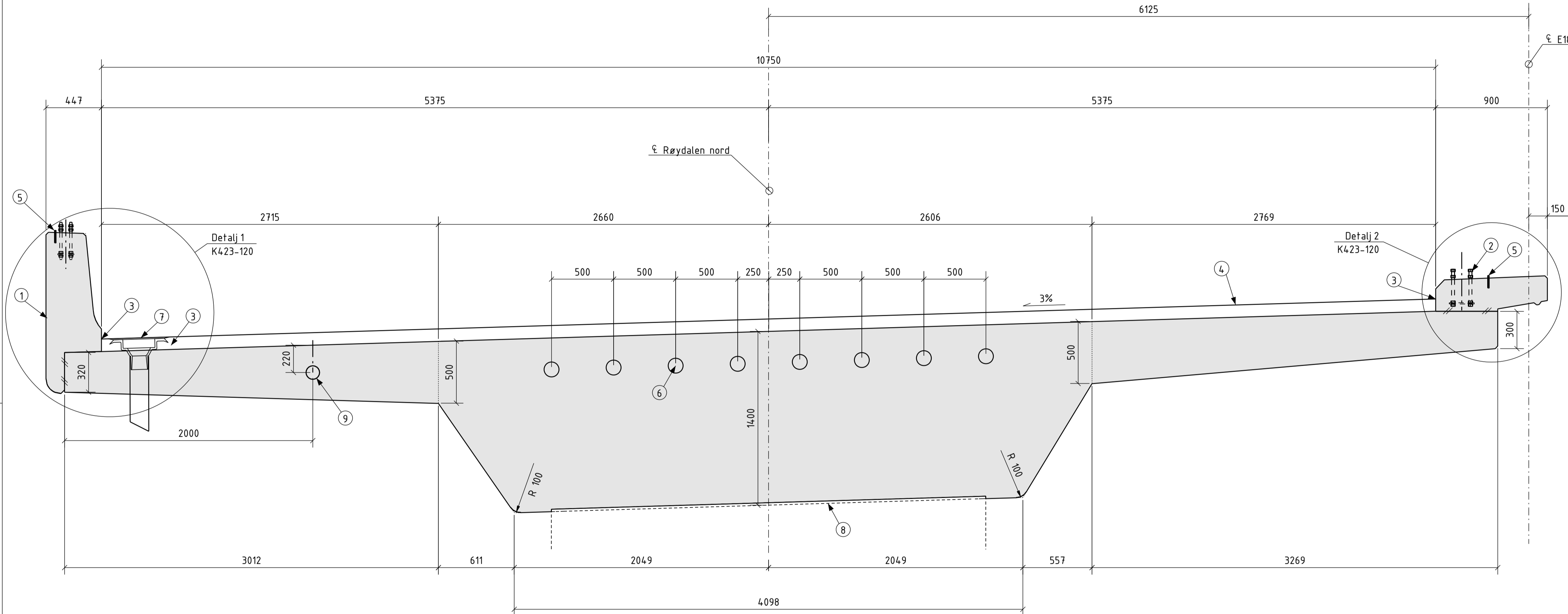

Typisk brutverrsnitt

A1=1:20  
A3=1:40

Som utført		KV	HENK	JASAT	
Revisjon	Revisjonen gjelder	Utarb.	Kontr.	Godkj.	Rev dato
Godkjent som arbeidstegning ifølge notat fra Vegdirektoratet					Arkivref. 15/206272-30
Utdratt av:					2017-06-26
NyeVeier		Utdratt av:		Utdratt av:	Tegningsdato
					2019-03-15
					Bestiller
					-
					Produsert for
					Nye Veier
					Prosjektnummer
					404
					Arkivreferanse
					Byggersnummer
					09-2637
					Koordinatsystem
					Euref89 NTM sone 8
					Høyde-system
					NN2000
					Målestokk A1
					1:20
					Målestokk A3
Som utført		Konsulentarkiv		Tegningsnummer /	
Utarbeidet av	Kontrollert av	Godkjent av	Konsulentarkiv	revisjonsbokstav	
KV	HENK	JASAT	5168070	K423-110	

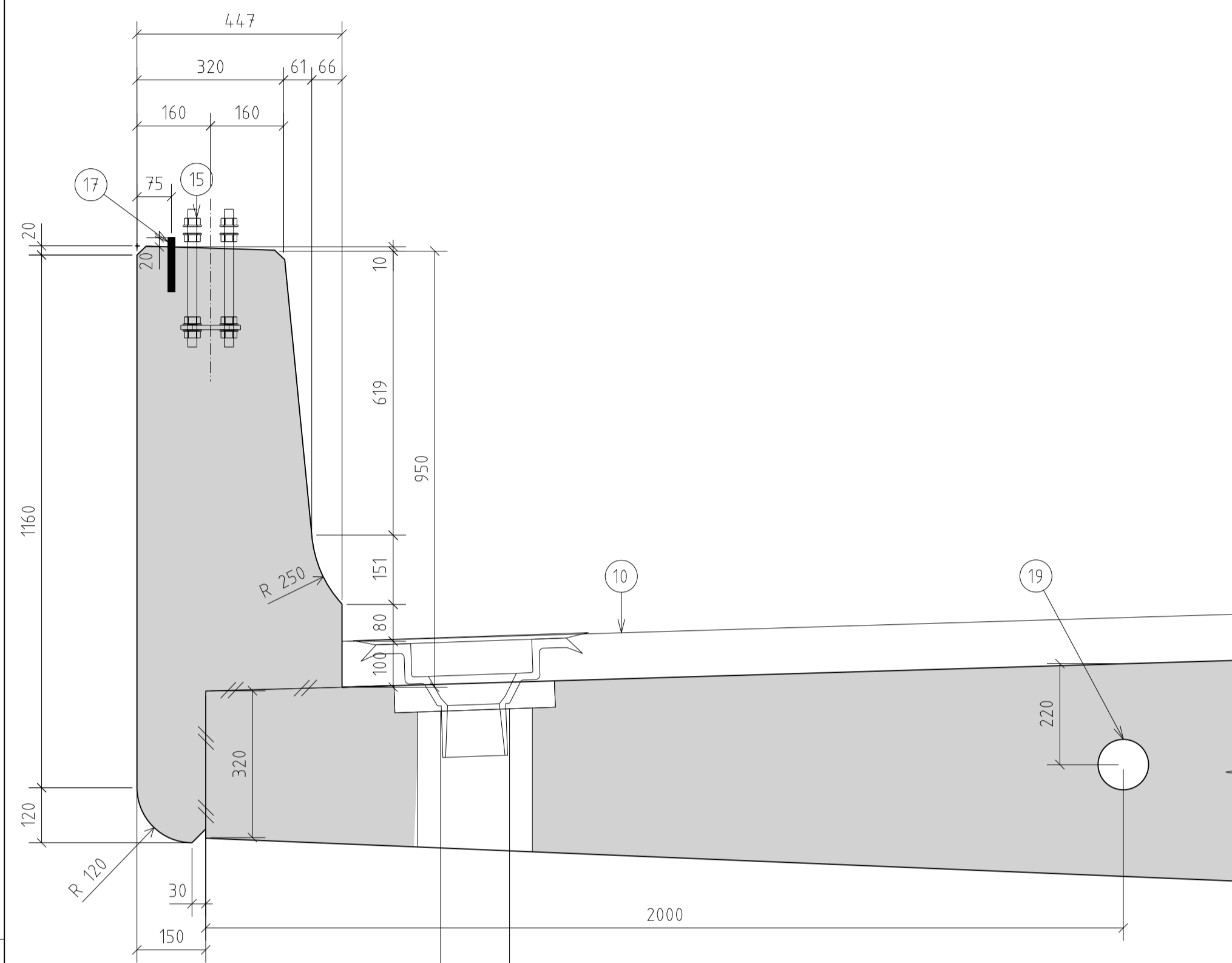

Detalj 1  
K4.23-110  
A1=1:10  
A3=1:20

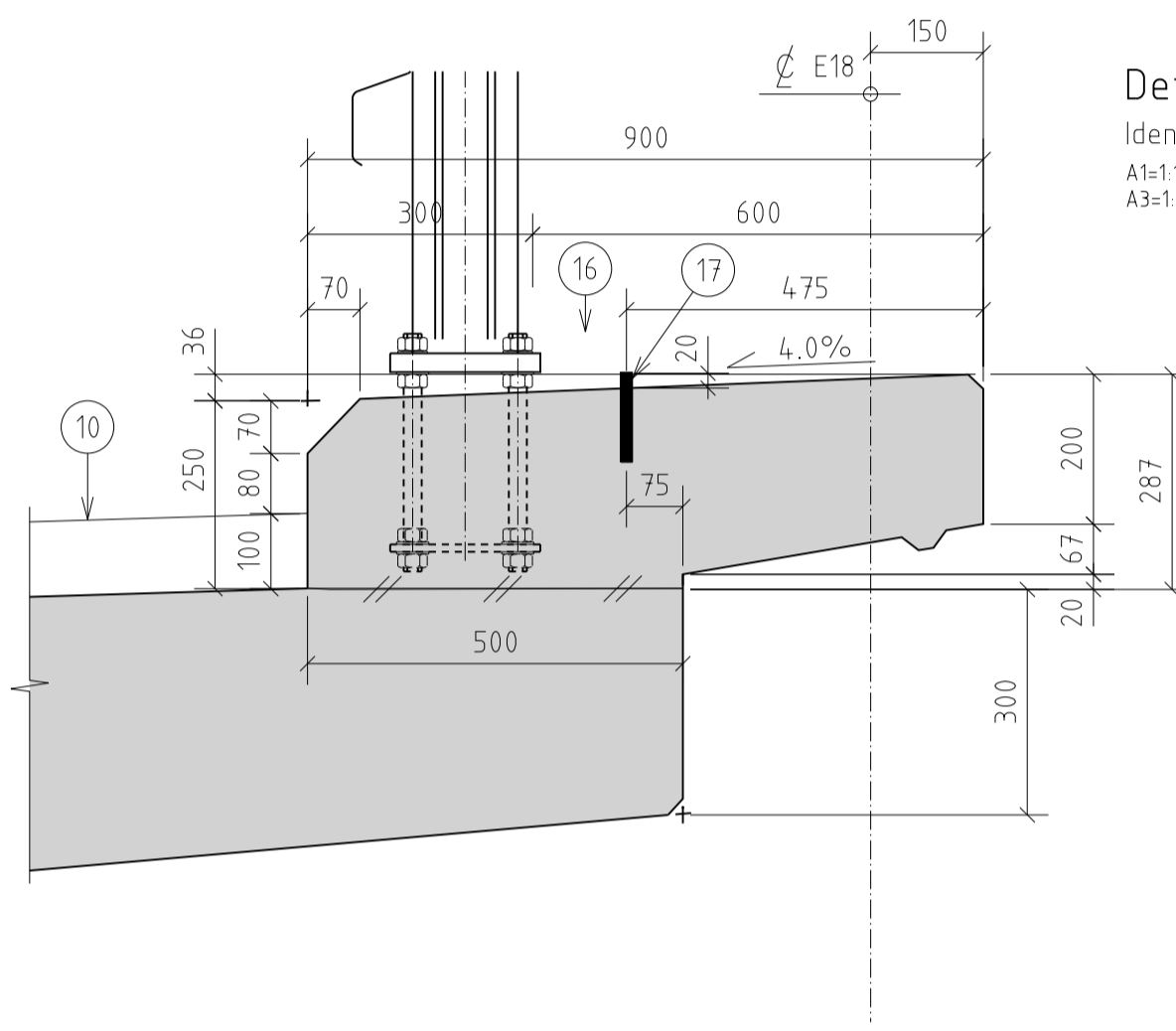

Detalj 2  
K4.23-110  
A1=1:10  
A3=1:20

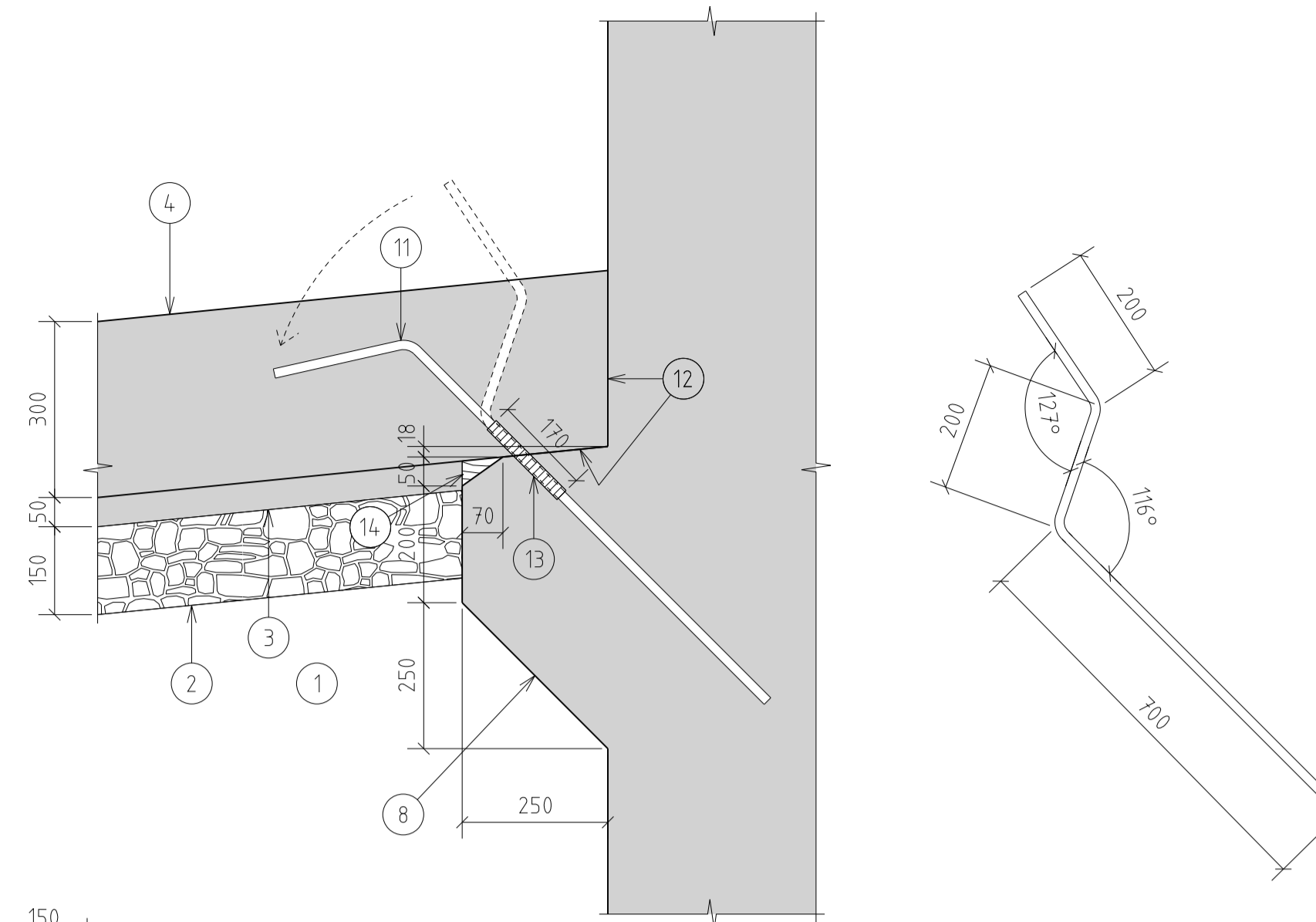

Detalj 3  
Identisk oppleggsdetalj i akse 1n og på bakveggen i akse 7n.  
A1=1:10  
A3=1:20

Målsatt forankringsjern 11  
A1=1:10  
A3=1:20

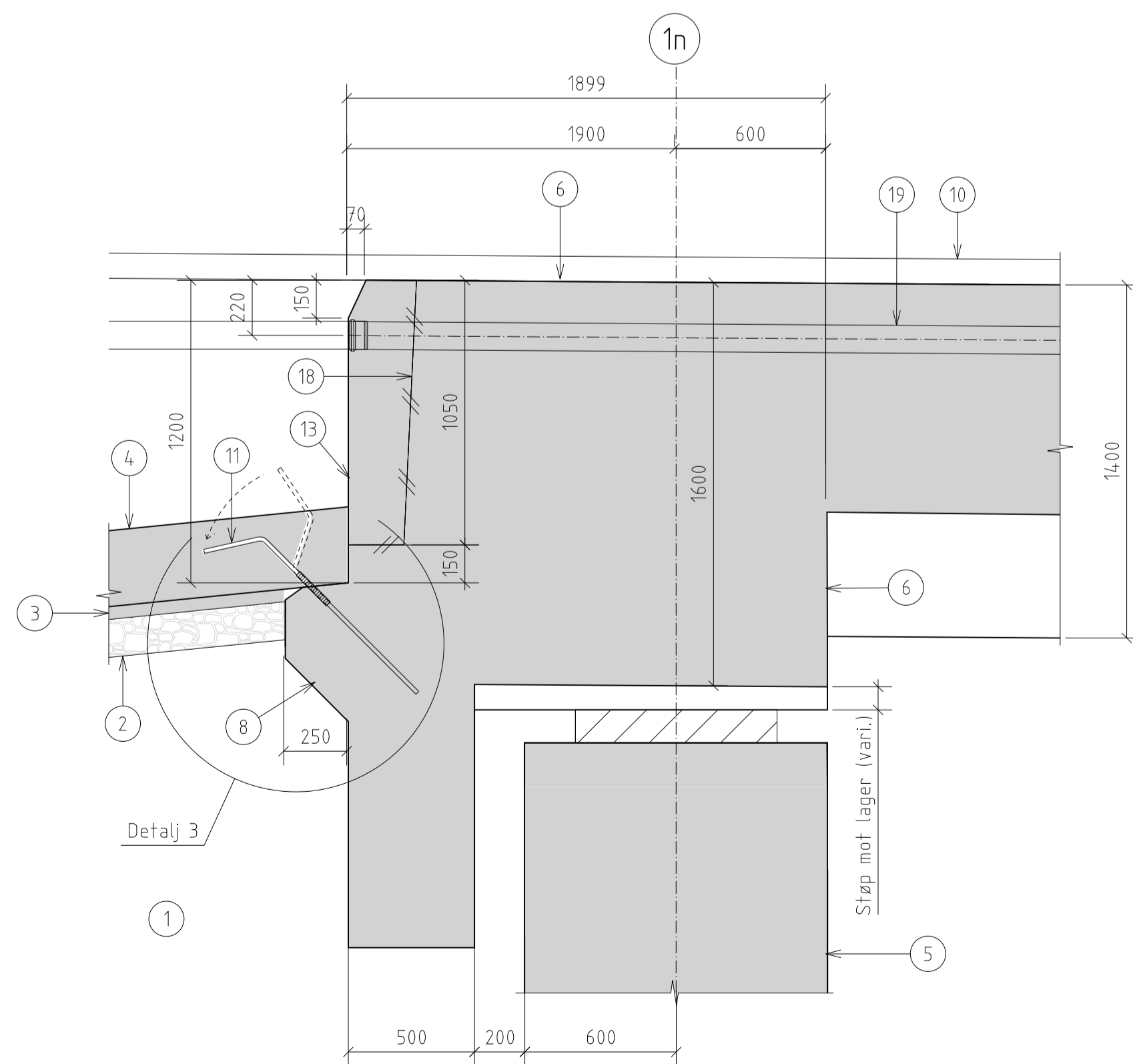

Snitt endetverrbjelke akse 1n  
A1=1:20  
A3=1:40

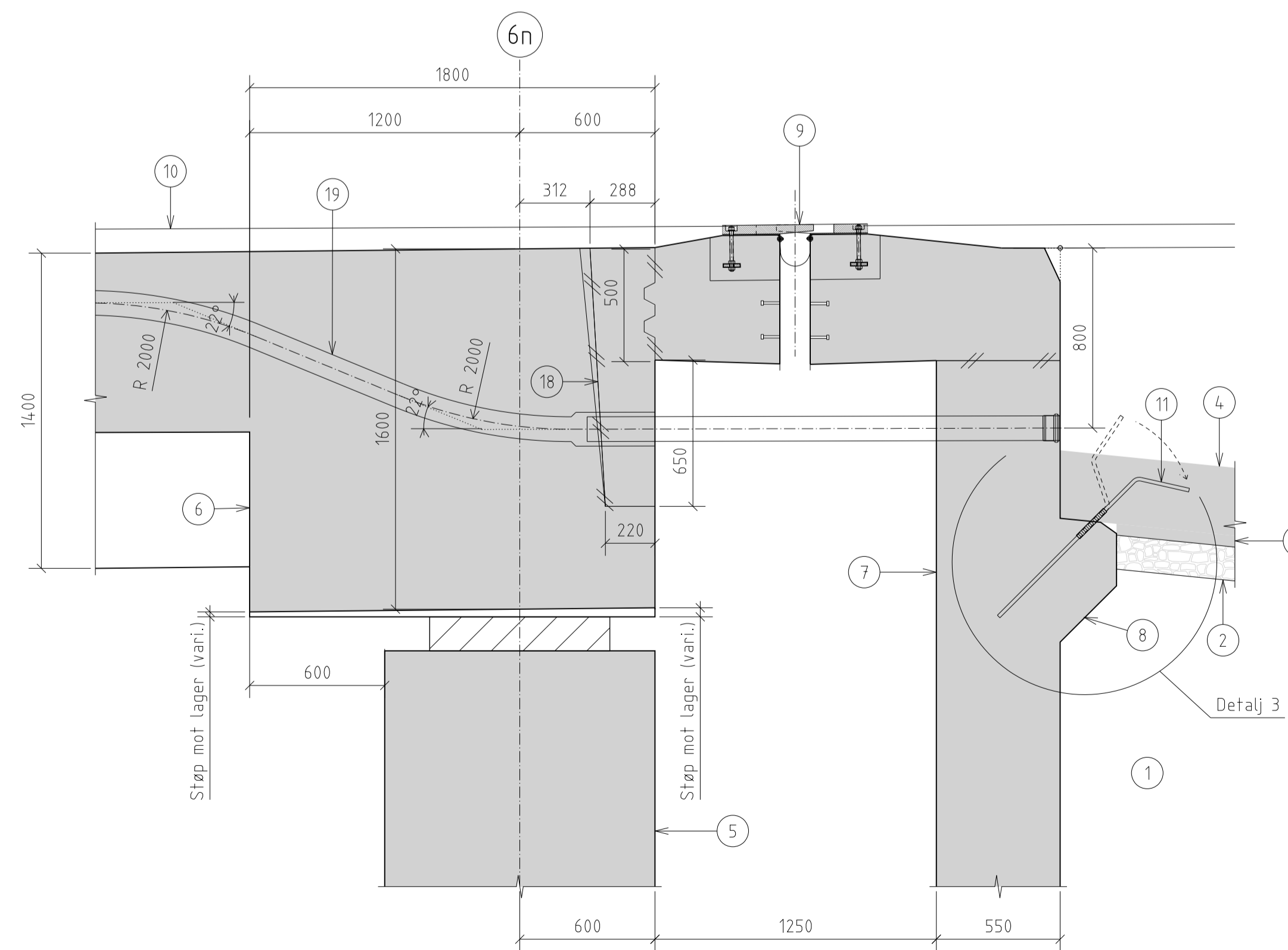

Snitt endetverrbjelke/fugerom/bakvegg akse 7n  
A1=1:20  
A3=1:40

## Merknader:

### 1. Betongkonstruksjoner

- Materialkvalitet: B45 SV-Standard
- Betong: B500NC (NS 3576-3)
- Bestandighetsklasse: MF40
- Tilslag: Dmaks=22 mm
- Luffinnhold: 4,5 +/- 1,5%
- Luffinnhold betongrekkeverk: 5,5 +/- 1,5%
- Overdekning: iht. håndbok N400 (2015 + NA - Rundskriv 2016/12) (se armeringstegninger)
- Nøyaktighetsklasse: B iht. prosesskoden
- Generelt: A iht. prosesskoden
- Kantbjelke/betongrekkeverk: A iht. prosesskoden
- Synlige skarpe hjørner avfases 20x20 mm dersom annet ikke er angitt

### 2. Prosjekterings- og utførelsesklasser

- Pålitelighetsklasse: 3 iht. NS-EN 1990:2002+NA:2008 [tab.NA.A1(901)]
- Kontrollklasse: Utførelse (U) iht. NS-EN 1990:2002+NA:2008 (NA.A1.3.1)
- Utførelsesklasse, betong: 3 iht. NS-EN 13670:2009+NA:2010

MERK:  
Alle mål for fellestlandlandkarene i endeaksene er gitt på tegninger for bru 09-2605 K422 Røydalen sørgående bru.  
Akse 1:  
Se tegningene K422-010 til K422-012  
Akse 7:  
Se tegningene K422-070 til K422-072

### Tegnforklaringer:

- 1 Fylling med sprengstein
- 2 Avrettingslag 150 mm. Fk 22-63 mm
- 3 Betongavretting 50 mm, min. kvalitet B30
- 4 Overgangsplate, lengde 4,0 m, tykkelse 300 mm.
- 5 Landkarsøyle (opplegg for lager). For målsetting se 09-2605 Røydalen bru sør.
- 6 Endetverrbjelke. Høydel 1600 mm
- 7 Bakvegg, for målsetting se 09-2605 Røydalen bru sør. Tegn. K422-070 til -072
- 8 Konsoll
- 9 Fuge. Se tegn. K423-161
- 10 Overkant slitelag/asfalt
- 11 ø12x150 med L=1100 mm i syrefast kvalitet iht. NS-EN-10088 nr. 1.4362. Armeringsstiftet skal ha kammer og tilfredsstillende mekaniske egenskaper som angitt i NS3573-050 pkt. 7, herunder duktilitet og flytegrense fy/bruddgrense fu større eller lik 500 MPa/600 MPa
- 12 2 lag asfaltpapp mot overgangsplate, A-kvalitet
- 13 Krypplast 170 mm
- 14 Formbar oppskummet trekantprofil med tette kryssbundne celler, f.eks. av typen etylen-vinyl-acetat copolymer med servicetemperatur minimum +/- 50 grader og densitet > 45 kg/m<sup>3</sup>. Beholdes under støping av overgangsplate. Dimensjon 70x50 mm.
- 15 Boltegruppe for støyskjerm se tegn. K423-150
- 16 Boltegruppe for lavt brurekkverk se tegn. K423-150
- 17 Nivelleringsbolt ø16 L=120 mm. Boltene skal ha kvalitet rustfritt stål A4-80 i henhold til NS-EN ISO 3506 eller være i messing. Boltene støpes fast samtidig med støp av kantbjelke. For plasseringer se plantegningene, dvs. K423-101 til -106
- 18 Se tegning K423-202 for mål av utsparring for spennkabler
- 19 Typisk trekkerørføring. Trekkerøret er plassert med 220 mm avstand fra overkant betong til senter rør. Ved bruene føres det ned med 22° bend. Føres ut av brua i en avstand på 800 mm fra overkant betong til senter rør. Trekkerøret plasseres i brutvernsnittet som vist på tegn. K423-110.

Revisjon	Revisjonen gjelder	KV	HENK	JASAT	Rev dato	
Godkjent	som arbeidstegning ifølge notat fra Vegdirektoratet	Arkivref	15/206272-30	Godkjent	2017-06-26	
Som utført		Utført av	AF GRUPPEN		Tegningsdato	2019-03-15
E18 Tvedestrand - Arendal		Bestiller	Nye Veier		Prosjektnummer	404
04 Sagene - Pilestjenn		Arkivreferanse	-		Byggesaksnummer	09-2637
K423 Røydalen bru, nordgående		Koordinatsystem	Euref89 NTM sone 8		Haydesystem	NN2000
Snitt og detaljer		Målestokk A1	1:20/1:10		Målestokk A3	1:10/1:5
Som utført		Kontrollert av	Godkjent av	Konsulentarkiv	Tegningsnummer / revisjonsbestav	K423-120
Utført av	HENK	JASAT	5168070			

AVSTAND (m)	21	20	19	18	17	16	15	14	13	12	11	10	9	8	7	6	5	4	3	2	1	0	27	26	25	24	23	22	21	20	19	18	17	16	15	14	13	12	11	10	9	8	7	6	5	4	3	2	1	0
"Z"	741	700	646	592	540	495	456	427	410	400	400	400	400	400	400	417	470	548	644	751	854	961	1057	1135	1187	1205	1177	1089	983	879	783	681	572	464	359	273	213	195	195	195	195	195	195	195	213	273	359	464	572	

Oppspenningsrekkefølge	
Støpefase 1	A1, C1, F1, H1
Støpefase 2	B2, D2, E2, G2
Støpefase 3	A3, C3, F3, H3
Støpefase 4	B4, D4, E4, G4, A5, C5, F5, H5

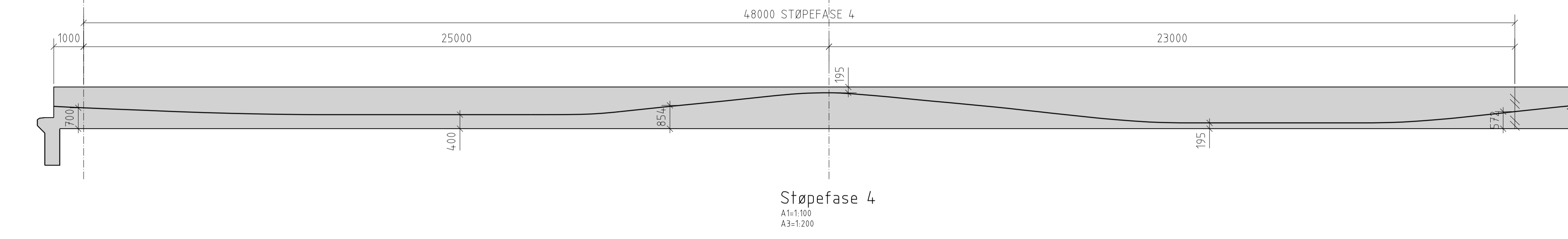

Støpefase 4  
A1=1:100  
A3=1:200

AVSTAND (m)	30	29	28	27	26	25	24	23	22	21	20	19	18	17	16	15	14	13	12	11	10	9	8	7	6	5	4	3	2	1	0
"Z"	572	680	783	879	983	1089	1176	1205	1177	1089	983	879	783	681	572	464	359	273	213	195	195	195	195	195	195	195	213	274	359	464	572

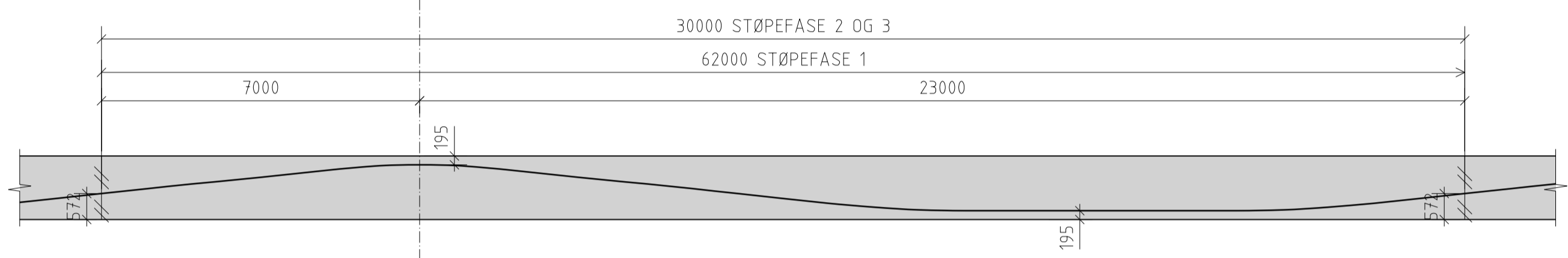

Støpefase 1, 2 og 3  
A1=1:100  
A3=1:200

AVSTAND (m)	32	31	30	29	28	27	26	25	24	23	22	21	20	19	18	17	16	15	14	13	12	11	10	9	8	7	6	5	4	3	2	1	0
"Z"	572	680	783	879	983	1089	1177	1205	1187	1135	1057	961	854	751	644	548	470	417	400	400	400	400	400	400	400	410	428	458	497	542	593	647	700

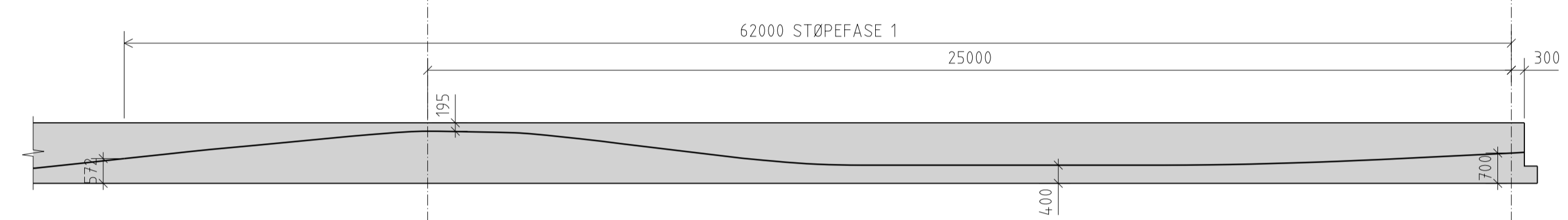

Støpefase 1  
A1=1:100  
A3=1:200

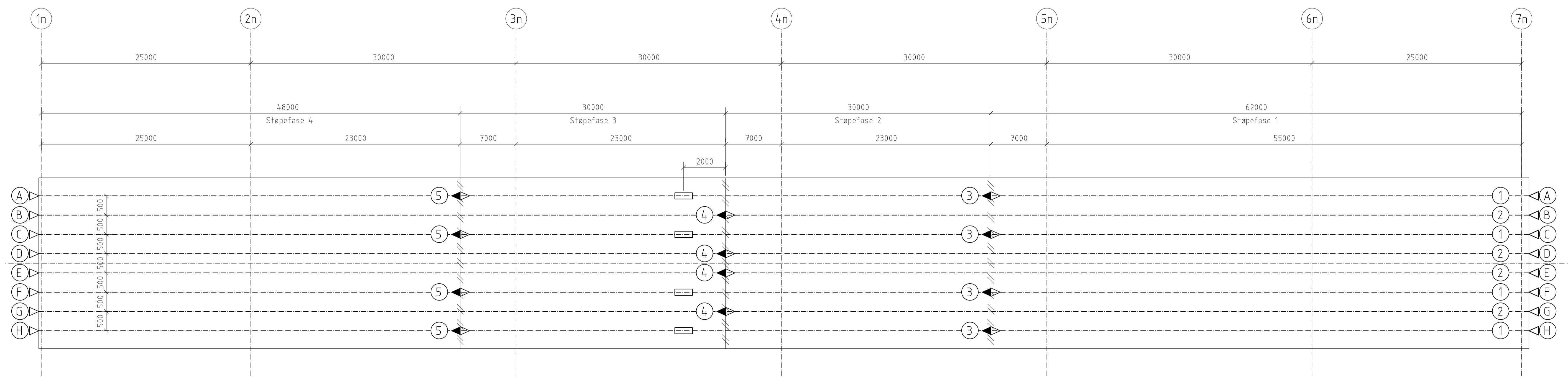

Plan støpefaser  
Ikke i målestokk

**Merknader:**

**1. Betongkonstruksjoner**

- Materialkvalitet: B45 SV-Standard
- Betong: B500NC (INS 3576-3)
- Slakkearmering: MF40
- Bestandighetsklasse: Dmaks=22 mm
- Tilslag: 4,5 +/- 1,5%
- Luftinnhold: 5,5 +/- 1,5%
- Luftinnhold betongrekkverk: iht. håndbok N4.00 (2015 + NA - Rundskriv 2016/12) (se armeringstegninger)
- Overdekning:
- Nøyaktighetsklasse: B iht. prosesskoden
- Generelt: A iht. prosesskoden
- Kanfbjelke/betongrekkverk: A iht. prosesskoden
- Synlige skarpe hjørner avfases 20x20 mm dersom annet ikke er angitt

**2. Prosjekterings- og utførelsesklasser**

- Pålitelighetsklasse: 3 iht. NS-EN 1990:2002+A1:2005+NA:2016 (tab.NA.A1(9011))
- Kontrollklasse: Utvidet (U) iht. NS-EN 1990:2002+A1:2005+NA:2016 (NA.A1.3.1)
- Utførelsesklasse, betong: 3 iht. NS-EN 13670:2009+NA:2010

**3. Spennarmering**

- Totalt 8 stk. spennkabler, hver med 22 stk. 0,62" spenntau
- Stålkvalitet:  $f_{pk}/f_{p0,1k} = 1860/1640$  MPa
- Areal: 22 stk. x 150 mm<sup>2</sup> = 3300 mm<sup>2</sup>/kabel
- Oppspenningskraft etter løsetap:  $0,85 \times F_{p0,1} = 4600$  kN/kabel
- Minimum betongfasthet ved oppspenning skal være 40 Mpa
- Forankringene skal monteres uforskyvelige i formen slik at ankerplaten står vinkelrett på spennarmeringens (kabelrørets) senterlinje i den ferdige konstruksjonen.
- Ved forankringer skal kabelleverandørens krav til rett linje på kabel oppfylles.
- Tillatt avvik fra angitt kabelplassering: vertikalt og horisontalt: +/- 10 mm.
- Alle spennkablenes ankerhoder skal fra leverandør være utstyrt med standard spiralarmring

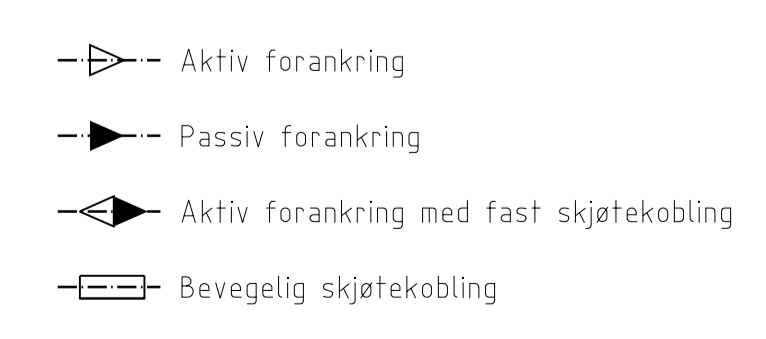

Som utført	KV	HENK	JASAT	
Revisjon	Utarb.	Kontr.	Godkjent	Rev dato
Godkjent som arbeidstegning ifølge notat fra Vegdirektoratet	Arkivref: 15/206272-30	Godkjent		2017-06-26
NyeVeier		Utferet av		
E18 Tvedestrand - Arendal		Arkivreferanse		
04 Sagene - Piletjenn		Tegningsdato		
K423 Røydalen bru, nordgående		Bestiller		
Spennkabler		Produsert for		
Kabelføring		Nye Veier		
Som utført		Prosjektnummer		
Utarbeidet av	KV	Kontr.	HENK	404
Kontr.	HENK	Godkjent av	JASAT	
Konsulentarkiv		Byggesnummer		
5168070		09-2637		
		Koordinatsystem		
		Euref89 NTM some 8		
		Målestokk		
		NN2000		
		Målestokk A1		
		1:100		
		Hålv målestokk A3		
		1:200		
		Tegningsnummer / revisjonsbetav		
		K423-201		

## Appendix B

### B.1 Hand calculations

#### B.1.1 Geometry and cross-section constants

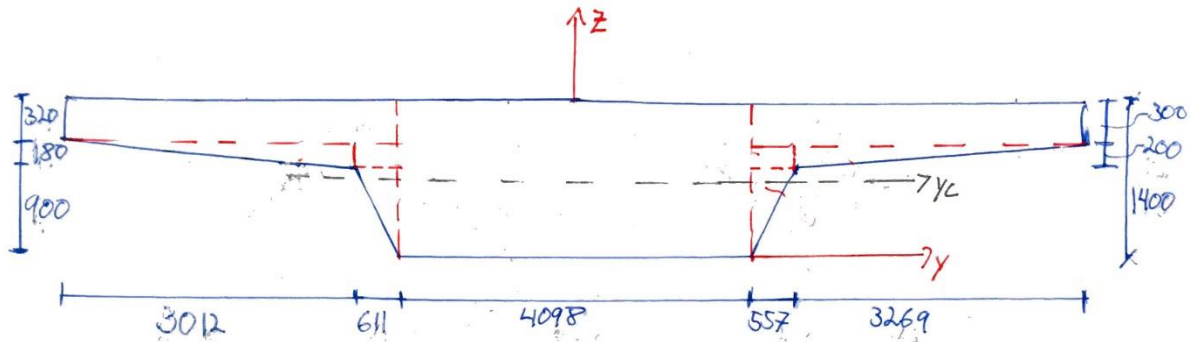

Figure B-1: Cross-section constants used in hand calculations [mm]

#### B.1.2 Cross-section area

$$A_{Total} = \int_0^{hT} dA = \sum A_i$$

$$z_c = \frac{\sum A_i \cdot z_i}{\sum A_i}$$

$$I_{y,i} = \int_A z^2 dA$$

$$I_{y,tot} = \sum I_i + A_i \cdot z_i^2$$



### B.1.3 Hardy Cross

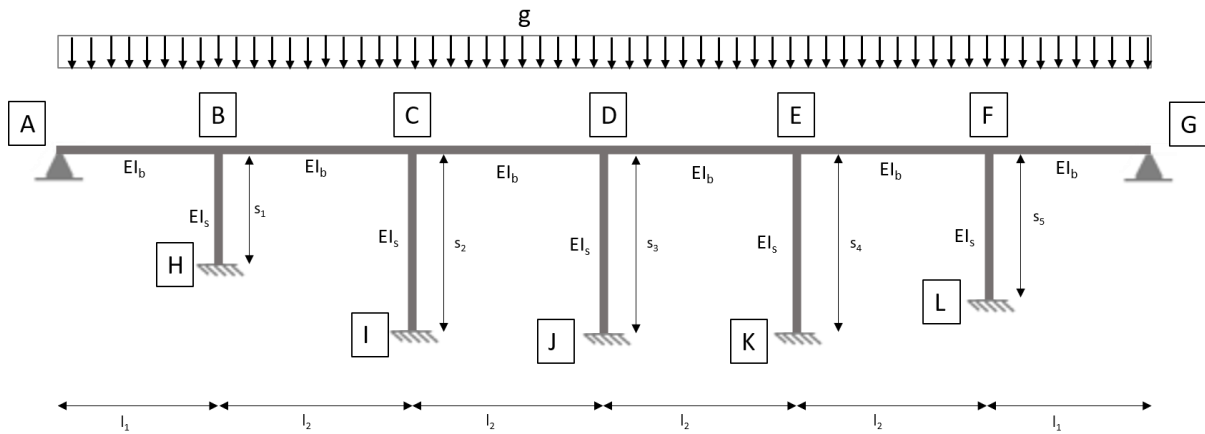

Figure B-2: Static model excited by self-weight

Table B-1: Geometric constants to figure B-2

Notation	L <sub>1</sub> [mm]	L <sub>2</sub> [mm]	S <sub>1</sub> [mm]	S <sub>2</sub> [mm]	S <sub>3</sub> [mm]	S <sub>4</sub> [mm]	S <sub>5</sub> [mm]
Value	25 000	30 000	16 500	26 500	26 500	26 500	22 500

Table B-2: Input variables to Hardy-Cross

Notation	g [kN/m]	E <sub>c</sub> [N/mm]	I <sub>b</sub> [m <sup>4</sup> ]	I <sub>s</sub> [m <sup>4</sup> ]	A <sub>beam</sub> [m <sup>2</sup> ]	A <sub>s</sub> [m <sup>2</sup> ]
Value	234,75	36 283	1,544	0,179	9,39	2,975



Figure B-3: Simplified bending moments for end and mid spans, screenshot from "Structural Analysis", R.C. Hibbeler

**TABELL 3.4 STIVHETSRELASJONER FOR BJELKER**

	Skjærkraft V	Moment M
	$\frac{3EI}{L^2} \cdot \theta$	$\frac{3EI}{L} \cdot \theta$
	$\frac{6EI}{L^2} \cdot \theta$	$\frac{4EI}{L} \cdot \theta$

Figure B-4: Stiffness relations k, screenshot from "Stålkonstruksjoner – Profiler og Formler"

Distribution factor (D.F.):

$$(D.F.)_{ij} = \frac{k_{ij}}{\sum k_i}$$

Balanced M:

$$D.F. \cdot \sum M$$

Table B-3: Calculated moments from fixed ends and stiffness relations

Position	FEM [kNm]	k
AB	0	8,96
BA	18 339,84	6,72
BC=CB=CD=DC=DE=ED=EF=FE	17 606,25	5,60
FG	18 339,84	6,72
GF	0	8,96
BH	0	1,5755
CI=DJ=EK	0	0,981
FL	0	1,155

Table B-4: Cross-method for Røydalen Bridge excited by self-weight

Boundary Condition	Pin ned	Monolithic				Monolithic			Monolithic			Roll er	Fixed	Fixed	Fixed
Node	A	B			C=D=E			F			G	H	I=J=K	L	
Element	AB	BA	BH	BC	CB	CI	CD	FE	FL	FG	GF	HB	IC	LF	
Sum Df	1	1				1			1			1	0	0	0
D.F	1,0	0,48	0,11	0,4	0,46	0,08	0,46	0,42	0,09	0,50	1,0	0	0	0	
FEM	0	18 339,84	0	-17 606,5	17 606,5		-17 606,5	17 606,5	0	-	0	0	0	0	
Balanced	0	354,77	83,18	295,64	0	0	0	-304,87	-62,88	18 339,84	0	0	0	0	
Transferr ed		0	0	-147,82				-152,44				41,59		-31,44	
Balanced		-71,49	-16,76	-59,57				12,67	2,61	15,12					
Transferr ed		0		-29,79				-6,33				-8,38		1,31	
Balanced		-14,41	-3,38	-12,00				-2,63	-0,54	-3,16					
Transferr ed				-6,0				-1,32				-1,69		-0,27	
Balanced		-2,9	-0,68	-2,42				-0,55	-0,11	-0,66					
Transferr ed				-1,21				-0,27				-0,34		-0,06	
Balanced		-0,58	-0,14	-0,49				-0,11	-0,02	-0,14					
Transferr ed				-0,24				-0,02				-0,07		-0,01	
Balanced		-0,12	-0,03	-0,1				0	0	-0,03					
Transferr ed				-0,05				0				-0,01		0	
Balanced		-0,02	-0,01	-0,02						-0,01					
REST				-0,01								0		0	
Sum M		18 605,09	62,19	-17,570	17 606,25		-	17 150,30	-60,95	18 511,55		31,09		-30,48	

Results in table B-3 forms the basis for calculation of the reaction forces and span moments. Because of symmetry only the spans AB and BC are calculated.

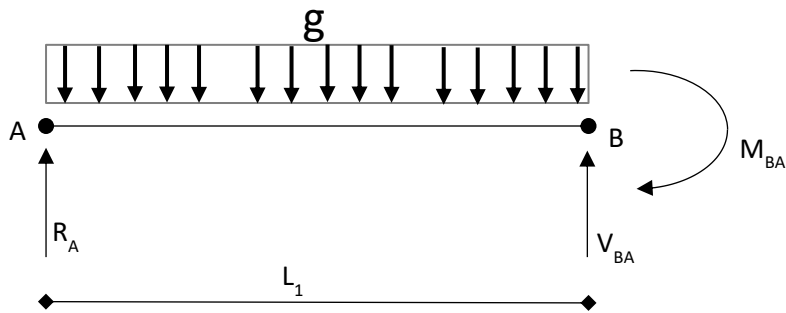
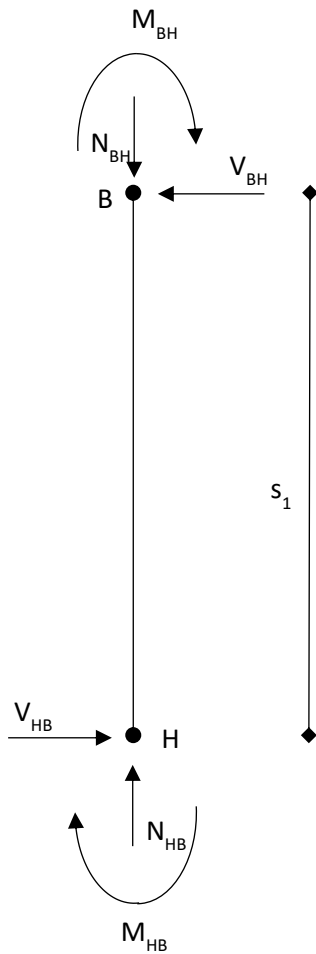

Figure B-5: Element AB/BA

$$\sum M_B = R_A \cdot L_1 - g \cdot L_1^2 \cdot \frac{1}{2} + M_{BA} = 0 \rightarrow R_A = 2\,190,17 \text{ kN}$$

$$\sum F_Y = V_{BA} + R_A - g \cdot L_1 \rightarrow V_{BA} = 3\,678,98 \text{ kN}$$



$$N_{BH} = N_{HB} = V_{BH} + V_{BA} = 3\,678,58 + 3\,521,25 = 7\,199,83 \text{ kN}$$

$$\sum M_B = M_{HB} - V_{HB} \cdot s_1 + M_{BH} = 0 \rightarrow V_{HB} = V_{BH} = 5,65 \text{ kN}$$

Figure B-6: Element BH/HB

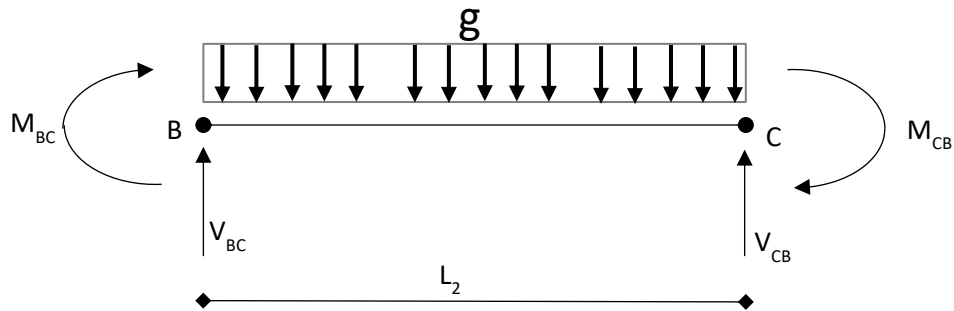

Figure B-7: Element BC/CB

$$\sum M_C = V_{BC} \cdot L_2 - g \cdot L_2^2 \cdot \frac{1}{2} = 0 \rightarrow V_{BC} = V_{CB} = 3521,25 \text{ kN}$$

Bending moment in span BC:

$$M(x) = V_{BC} \cdot x - g \cdot x^2 \cdot \frac{1}{2} - M_{BC} \rightarrow M_{(15)} = 8\,839,04 \text{ kNm}$$

Bending moment in span AB:

$$M(x) = R_A \cdot x - g \cdot x^2 \cdot \frac{1}{2} \rightarrow V(x) = R_A - g \cdot x$$

$$V(x) = 0 \rightarrow x = 9,33 \text{ m} \quad M_{(9,33)} = 10\,216,93 \text{ kNm}$$

```
1 using System;
2 using System.Collections.Generic;
3 using System.IO;
4 using System.Linq;
5
6 using System.Windows.Forms;
7 using static System.FormatableString;
8
9 namespace SkriveAseFiler
10 {
11     public partial class Form1 : Form
12     {
13         public Form1()
14         {
15             InitializeComponent();
16         }
17
18         private void btnVelgPlass_Click(object sender, EventArgs e)
19         {
20             var saveFileDialog1 = new SaveFileDialog();
21             saveFileDialog1.Filter = "Dat file|*.dat";
22             saveFileDialog1.Title = "Save as Sofistik dat file";
23             if (saveFileDialog1.ShowDialog() == DialogResult.OK)
24             {
25                 if (saveFileDialog1.FileName != "")
26                 {
27                     var tst = LagListe();
28                     Console.WriteLine(tst);
29                     File.WriteAllLines(saveFileDialog1.FileName, tst);
30                 }
31             }
32         }
33
34         private List<string> LagListe()
35         {
36             var TrafikkLaster = Enumerable.Range(10000, 172).ToList();
37             var Templaster = Enumerable.Range(91, 8).ToList();
38             var egenfaktor = 1.0;
39             var spennfaktor = 1.1;
40             var faktorTrafikk = 0.945;
41             var faktorTemp = 1.2;
42             var tekst = new List<string>();
43             var startNr = 200;
44             foreach (var elem in TrafikkLaster) //for(int
45                 i=0;i<TrafikkLaster.Count;i++)
46             {
47                 tekst.Add("+prog ase");
48                 tekst.Add("Head");
49                 tekst.Add("Echo MAT Yes");
```

```
49     tekst.Add("Echo grp,load no");
50     tekst.Add("CTRL ITER 3 V2 1          $ better iteration");
51     tekst.Add(Invariant($"REIN LCR {startNr}"));
52     tekst.Add("SYST PROB TH3 PLC 102 TOL -10.0 fmax 2.0 iter - $ ↗
    Geometrisk ikke - lineæritet");
53     tekst.Add("DESI ULTI KSV ULD KSB ULD $ AMAX FIXL  $ AMAX ↗
    improves cross-section iteration");
54     tekst.Add("NSTR kmod K1 KSV SLD KSB SLD fmax 0.8 $ material ↗
    ikke-lineæritet");
55     tekst.Add("GRP 'CSM' LINE CS 32");
56     tekst.Add("GRP 5 FULL CS 32 T1 0");
57     tekst.Add(Invariant($"LC {startNr} FACD 1.0 titl 'TH3' $ FACD ↗
    activates g_1 "));
58     tekst.AddRange(StandardLaster(egenfaktor, spennfaktor));
59     tekst.Add(Invariant($"LCC {elem} fact {faktorTrafikk} $ ↗
    Trafikk"));
60     tekst.Add("End");
61     tekst.Add(" ");
62     startNr++;
63     foreach (var temp in Templaster)
64     {
65         tekst.Add("+prog ase");
66         tekst.Add("Head");
67         tekst.Add("Echo MAT Yes");
68         tekst.Add("Echo grp,load no");
69         tekst.Add("CTRL ITER 3 V2 1          $ better iteration");
70         tekst.Add(Invariant($"REIN LCR {startNr}"));
71         tekst.Add("SYST PROB TH3 PLC 102 TOL -10.0 fmax 2.0 iter - ↗
    $ Geometrisk ikke - lineæritet");
72         tekst.Add("DESI ULTI KSV ULD KSB ULD $ AMAX FIXL  $ AMAX ↗
    improves cross-section iteration");
73         tekst.Add("NSTR kmod K1 KSV SLD KSB SLD fmax 0.8 $ material ↗
    ikke-lineæritet");
74         tekst.Add("GRP 'CSM' LINE CS 32");
75         tekst.Add("GRP 5 FULL CS 32 T1 0");
76         tekst.Add(Invariant($"LC {startNr} FACD 1.0 titl 'TH3' $ ↗
    FACD activates g_1 "));
77         tekst.AddRange(StandardLaster(egenfaktor, spennfaktor));
78         tekst.Add(Invariant($"LCC {elem} fact {faktorTrafikk} $ ↗
    gr1a"));
79         tekst.Add(Invariant($"LCC {temp} fact {faktorTemp} $ ↗
    Temp"));
80         tekst.Add("End");
81         tekst.Add(" ");
82         startNr++;
83     }
84 }
85
86     return tekst;
```

```
87     }
88     private List<string> StandardLaster(double EgenFaktor, double      ↗
      spennFaktor)
89     {
90         var liste = new List<string>();
91         liste.Add(Invariant($"LCC 2 fact {EgenFaktor}   PLC YES $ g_2"));
92         liste.Add(Invariant($"LCC 3 fact {EgenFaktor}   PLC YES $ g_2"));
93         liste.Add(Invariant($"LCC 4 fact {EgenFaktor}   PLC YES $ g_2"));
94         liste.Add(Invariant($"LCC 5 fact {EgenFaktor}   PLC YES $ g_2"));
95         liste.Add(Invariant($"LCC 50 fact {spennFaktor} PLC YES $      ↗
      prestress"));
96         return liste;
97     }
98
99     }
100 }
101
```

Røydalen\_NORD\_GSR

```
1 +PROG ASE
2 $ Dat : C:\...\røydalen_nord_gsr_full_020_6.10b.dat (#11n)      28.05.2021
3 $ Job : LAPTOP-03CNBSLK:001826                                11.09
4 HEAD
5 ECHO MAT YES
6 ECHO GRP,LOAD NO
7 CTRL ITER 3 V2 1      $ better iteration
8 REIN LCR 1554
9 SYST PROB TH3 PLC 102 TOL -10.0 FMAX 2.0 ITER -  $ Geometrisk ikke - lineæritet
10 DESI ULTI KSV ULD KSB ULD $ AMAX FIXL  $ AMAX improves cross-section iteration
11 NSTR KMOD K1 KSV SLD KSB SLD FMAX 0.8 $ material ikke-lineæritet
12 GRP 'CSM' LINE CS 32
13 GRP 5 FULL CS 32 T1 0
14 LC 1554 FACD 1.0 TITL 'TH3' $ FACD activates g_1
15 LCC 2 FACT 1  PLC YES $ g_2
16 LCC 3 FACT 1  PLC YES $ g_2
17 LCC 4 FACT 1  PLC YES $ g_2
18 LCC 5 FACT 1  PLC YES $ g_2
19 LCC 50 FACT 1.1 PLC YES $ prestress
20 LCC 10150 FACT 0.945 $ gr1a
21 LCC 94 FACT 1.2 $ Temp
22 END
```



Røydalen\_NORD\_GSR

**Analysis parameters**

Geometrical nonlinear analysis TH3

Nonlinear material properties are used for:

Truss-, cable-, springelements, pilebedding, QUAD-bedding  
 Beamelements

Only linear material properties are used for:

QUAD- and BRIQ-elements  
 Pile- und boundaryelements

**Maximum possible concrete stress for the design**

Nonlinear elements use the stress strain curve ULS ultimate limit state.

Mno	material safety	starting E-modul* [N/mm2]	max.- sigma* [N/mm2]	at strain [o/oo]	quad-max sigma-z [N/mm2]	quad-tension stiffening [N/mm2]
1	1.500	25500	-25.50	-2.00		
4	1.500	25500	-25.50	-2.00		
5	1.500	25500	-25.50	-2.00		

\* In the E-modulus and max.sigma the material safety is included.

For max sigma-z, fctd has been used. Tension stiffening includes the safety factor.  
 Linear switched elements use the linear E-modulus of AQUA.

**Maximum possible steel stress for the design**

Nonlinear elements use the stress strain curve ULS ultimate limit state.

Mno	material safety	starting E-modul* [N/mm2]	proportional limit* [N/mm2]	at strain [o/oo]	maximum stress* [N/mm2]	at strain [o/oo]
2	1.150	200000	434.78	2.17	469.57	50.00
3	1.150	195000	1391.30	7.13	1617.39	60.00

\* In the marked columns the material safety is included.

Linear switched elements use the linear E-modulus of AQUA.

**Maximum possible concrete stress for the calculation of the stiffness**

Nonlinear elements use the stress strain curve SLS serviceability limit state.

Mno	material safety	starting E-modul* [N/mm2]	max.- sigma* [N/mm2]	at strain [o/oo]	quad-max sigma-z [N/mm2]	quad-tension stiffening [N/mm2]
1	1.500	25398	-35.33	-2.40		
4	1.500	25398	-35.33	-2.40		
5	1.500	25398	-35.33	-2.40		

\* In the E-modulus and max.sigma the material safety is included.

In the tensile strenths the material safety factor is also included.

Linear switched elements use the linear E-modulus of AQUA.

**Maximum possible steel stress for the calculation of the stiffness**

Nonlinear elements use the stress strain curve SLS serviceability limit state.

Mno	material safety	starting E-modul* [N/mm2]	proportional limit* [N/mm2]	at strain [o/oo]	maximum stress* [N/mm2]	at strain [o/oo]
2	1.150	200000	434.78	2.50	469.57	50.00
3	1.150	195000	1391.30	8.21	1617.39	60.00

\* In the marked columns the material safety is included.

Linear switched elements use the linear E-modulus of AQUA.

Primary state for displacements of total system is load case 102

Røydalen\_NORD\_GSR

**Sum of Loadings**

Loadcase	Σ(Loads)		Designation
	X[kN]	Y[kN]	
1554	0.0	0.0	-68880.4 TH3

**Iteration sequence Loadcase 1554**

Iteration 1 Residual 138.518 energy 1.000 Step 1-1 f= 1.000  
 Update nonlinear stiffness

Iteration 2 Residual 34428.574 energy 1.000 Step 2-1 f= 1.000  
 accuracy AQB-NSTR: 1.497

Iteration 3 Residual 78516.531 energy 1.000 Step 2-2 f= 0.438  
 accuracy AQB-NSTR: 1.129

Iteration 4 Residual 49372.902 energy 1.000 Step 2-3 f= 0.258  
 accuracy AQB-NSTR: 1.115

Iteration 5 Residual 39798.480 energy 1.000 Step 2-4 f= 0.168  
 accuracy AQB-NSTR:0.5554

Iteration 6 Residual 35154.234 energy 1.000 Step 2-5 f= 0.114  
 accuracy AQB-NSTR:0.1781

Update nonlinear stiffness

Iteration 7 Residual 24637.898 energy 0.942 Step 3-1 f= 0.080  
 accuracy AQB-NSTR:0.1189

Update nonlinear stiffness

Iteration 8 Residual 14748.671 energy 0.883 Step 4-1 f= 0.161  
 accuracy AQB-NSTR:0.1281

Update nonlinear stiffness

Iteration 9 Residual 6373.456 energy 0.834 Step 5-1 f= 0.322  
 accuracy AQB-NSTR:0.1374

Update nonlinear stiffness

Iteration 10 Residual 1564.096 energy 0.805 Step 6-1 f= 0.569  
 accuracy AQB-NSTR:0.1122

Update nonlinear stiffness

Iteration 11 Residual 203.246 energy 0.797 Step 7-1 f= 0.757  
 accuracy AQB-NSTR:0.1162

Update nonlinear stiffness

Iteration 12 Residual 167.340 energy 0.796 Step 8-1 f= 0.889  
 accuracy AQB-NSTR:0.1191

Update nonlinear stiffness

Iteration 13 Residual 131.093 energy 0.795 Step 9-1 f= 1.455  
 accuracy AQB-NSTR:0.1450

Update nonlinear stiffness

Iteration 14 Residual 32.876 energy 0.796 Step 10-1 f= 2.910  
 accuracy AQB-NSTR:0.1954

Update nonlinear stiffness

Iteration 15 Residual 34.625 energy 0.795 Step 11-1 f= 3.586  
 accuracy AQB-NSTR:0.1020

Update nonlinear stiffness

Iteration 16 Residual 75.707 energy 0.796 Step 12-1 f= 3.896  
 accuracy AQB-NSTR:0.0952

Iteration 17 Residual 78.571 energy 0.796 Step 12-2 f= 0.402  
 accuracy AQB-NSTR:0.0174

Update nonlinear stiffness

Iteration 18 Residual 38.622 energy 0.795 Step 13-1 f= 0.803  
 accuracy AQB-NSTR:0.0398

Update nonlinear stiffness

Iteration 19 Residual 44.238 energy 0.795 Step 14-1 f= 1.484  
 accuracy AQB-NSTR:0.0485

Røydalen\_NORD\_GSR

Update nonlinear stiffness  
 Iteration 20 Residual 13.351 energy 0.795 Step 15-1 f= 2.968  
 accuracy AQB-NSTR:0.0720

Update nonlinear stiffness  
 Iteration 21 Residual 11.957 energy 0.795 Step 16-1 f= 3.892  
 accuracy AQB-NSTR:0.0402

Update nonlinear stiffness  
 Iteration 22 Residual 32.318 energy 0.796 Step 17-1 f= 7.070  
 accuracy AQB-NSTR:0.0553

Iteration 23 Residual 37.500 energy 0.796 Step 17-2 f= 0.295  
 accuracy AQB-NSTR:0.0162

Update nonlinear stiffness  
 Iteration 24 Residual 20.794 energy 0.795 Step 18-1 f= 0.590  
 accuracy AQB-NSTR:0.0127

Update nonlinear stiffness  
 Iteration 25 Residual 16.025 energy 0.795 Step 19-1 f= 1.180  
 accuracy AQB-NSTR:0.0169

Update nonlinear stiffness  
 Iteration 26 Residual 7.417 energy 0.795 Step 20-1 f= 2.359  
 accuracy AQB-NSTR:0.0230

Update nonlinear stiffness  
 Iteration 27 Residual 2.242 energy 0.795 Step 21-1 f= 4.384  
 accuracy AQB-NSTR:0.0216

**Results of nonlinear AQB analysis for beam sections:**

-----  
 Default design code is NS EuroNorm EN 1992-2:2005 (NA:2010) Betongkonstruksjoner (Norge) V 2020  
 Konstruksjon og Pålitelighetsklasse: B (vegbruer)

**Materials**

Mat Classification	
1	C 45/55 N (EN 1992)
2	B 500 B (EN 1992)
3	Y 1860 A (EN 1992)
4	C 45/55 Stivhetx 100 SW=0
5	C 45/55 N (EN 1992)

**Selected Beam Elements**

Selection	NoA	NoE	x[m]	Type	CS
BEAM	50000	50120			32

Biaxial bending, uniaxial stress calculated in principal axis  
 Reinforcement will be accounted for sectional values as defined in AQUA  
 Reinforcements saved as Design case No.1554

**Considered Load Cases**

LC	ACT	REF	CS	Designation	$\gamma-u$	$\gamma-f$	$\psi_0$	$\psi_1$	$\psi_2$	$\psi_{1inf}$	SUP
1554			gross	TH3	1.00	0.00	1.00	1.00	1.00	1.00	

Røydalen\_NORD\_GSR

**Design for Ultimate Loads - NS EuroNorm EN 1992-2:2005 (NA:2010) Betongkonstruksjoner**

Safety factors	$\gamma$ -c,t	$\gamma$ -c,c	$\gamma$ -c,s	$\gamma$ -s,s	$\gamma$ -s,p	$\gamma$ -s Biaxial bending
Strain limits	$\epsilon$ -c1	$\epsilon$ -c2	$\epsilon$ -s1	$\epsilon$ -s2	$\epsilon$ -z1	$\epsilon$ -z2 CTRL-options
	1.50	1.50	1.50	1.15	1.15	1.05
	-3.50	-2.00 <sup>1</sup>	$\delta = 1.00^2$	10.00	20.00	PIIA = 7

<sup>1</sup> Strain limits will be adopted to active stress strain definitions of material

<sup>2</sup> Value is obtained from maximum height of compression zone based on the redistribution grade  $\delta$  (EN 1992-1-1, 5.5)

**Parameters for reinforcements**

Minimum reinforcement for beams	Minimum reinforcement for columns	Compressive Member Limits e/h	Minimum reinforcement of the required section	Maximum reinforcements
0.13 [o/o]	1.00 [o/o]	3.50 <sup>1</sup>	0.0010 <sup>1</sup>	8.00 [o/o]

<sup>1</sup> A beam is taken as compressive member if the eccentricity e/h is less and the compressive force is larger than these limits

Tensile forces in the longitudinal reinforcements due to shear are NOT accounted for.  
Material of sections uses Ultimate Limit strain-stress law with individual safety factors  
Material of reinforcements uses Ultimate Limit strain-stress law with individual safety factors

**Applied material properties**

Mat	Temp	Safety	Max.compr	at	Max.tens	at	Tension-	Bond
Lev.	factor	stress	strain	stress	strain	stiffening	factor	
	[-]	[MPa]	[o/oo]	[MPa]	[o/oo]	[MPa]	[-]	
1	0	1.500	-25.50	-2.00	0.00	0.00	fc,t = 0.00	
2	0	1.150	-469.57	-50.00	469.57	50.00		
3	0	1.150	-1617.39	-60.00	1617.39	60.00		
4	0	1.500	-25.50	-2.00	0.00	0.00	fc,t = 0.00	
5	0	1.500	-25.50	-2.00	0.00	0.00	fc,t = 0.00	

**Required Reinforcements**

Beam	x[m]	SNo	LC	NRd	MyRd	MzRd	$\epsilon$ -1	$\epsilon$ -2	$\gamma$ -c	$\gamma$ -s	rel	As Lay.
				[kN]	[kNm]	[kNm]	[o/oo]	[o/oo]	[-]	[-]	[-]	[cm <sup>2</sup> ]
50001	0.000	9	1554	-61011.1	-5579.60	2149.10	-3.50	-0.17	1.50	1.15	6.02	15.84 0
												41.23 1
												41.23 2
												4.52 3
												0.75 T <sup>1</sup>
	1.000	9	1554	-63181.4	-5016.80	2092.80	-3.50	-0.28	1.50	1.15	6.19	15.84 0
												41.23 1
												41.23 2
												4.52 3
												0.75 T <sup>1</sup>
50002	0.000	9	1554	-63181.4	-5016.80	2092.78	-3.50	-0.28	1.50	1.15	6.19	15.84 0
												41.23 1
												41.23 2
												4.52 3
												0.75 T <sup>1</sup>
	1.000	9	1554	-65421.3	-4399.88	2031.01	-3.50	-0.38	1.50	1.15	6.36	15.84 0
												41.23 1
												41.23 2
												4.52 3
												0.75 T <sup>1</sup>
50003	0.000	9	1554	-65421.3	-4399.88	2030.98	-3.50	-0.38	1.50	1.15	6.36	15.84 0
												41.23 1
												41.23 2
												4.52 3
												0.75 T <sup>1</sup>

Røydalen\_NORD\_GSR

Required Reinforcements

Beam	x[m]	SNo	LC	NRd [kN]	MyRd [kNm]	MzRd [kNm]	ε-1 [o/oo]	ε-2 [o/oo]	γ-c [-]	γ-s [-]	rel [-]	As [cm <sup>2</sup> ]	Lay.
50003	1.000	9	1554	-67689.7	-3725.87	1958.89	-3.41	-0.11	1.50	1.15	6.54	15.84	0
												41.23	1
												41.23	2
												4.52	3
50004	0.000	9	1554	-67689.7	-3725.87	1958.89	-3.41	-0.11	1.50	1.15	6.54	15.84	0
												41.23	1
												41.23	2
												4.52	3
50004	1.000	9	1554	-70077.2	-3000.03	1885.09	-3.28	-0.30	1.50	1.15	6.72	15.84	0
												41.23	1
												41.23	2
												4.52	3
50005	0.000	9	1554	-70077.2	-3000.03	1885.09	-3.28	-0.30	1.50	1.15	6.72	15.84	0
												41.23	1
												41.23	2
												4.52	3
50005	1.000	9	1554	-72631.9	-2221.33	1808.40	-3.11	-0.51	1.50	1.15	6.91	15.84	0
												41.23	1
												41.23	2
												4.52	3
50006	0.000	9	1554	-72632.0	-2221.31	1808.39	-3.11	-0.51	1.50	1.15	6.91	15.84	0
												41.23	1
												41.23	2
												4.52	3
50006	1.000	9	1554	-75343.0	-1388.90	1727.39	-2.91	-0.79	1.50	1.15	7.12	15.84	0
												41.23	1
												41.23	2
												4.52	3
50007	0.000	9	1554	-75343.1	-1388.89	1727.38	-2.91	-0.79	1.50	1.15	7.12	15.84	0
												41.23	1
												41.23	2
												4.52	3
50007	1.000	9	1554	-78012.5	-493.67	1635.58	-2.61	-1.18	1.50	1.15	7.32	15.84	0
												41.23	1
												41.23	2
												4.52	3
50008	0.000	9	1554	-78012.6	-493.64	1635.62	-2.61	-1.18	1.50	1.15	7.32	15.84	0
												41.23	1
												41.23	2
												4.52	3
50008	1.000	9	1554	-78209.9	439.85	1487.87	-2.58	-1.23	1.50	1.15	7.29	15.84	0
												41.23	1
												41.23	2
												4.52	3

Røydalen\_NORD\_GSR

**Required Reinforcements**

Beam	x[m]	SNo	LC	NRd [kN]	MyRd [kNm]	MzRd [kNm]	ε-1 [o/oo]	ε-2 [o/oo]	γ-c [-]	γ-s [-]	rel [-]	As Lay. [cm <sup>2</sup> ]
50009	0.000	9	1554	-78209.8	439.87	1487.86	-2.58	-1.23	1.50	1.15	7.29	0.76 T <sup>1</sup>
												15.84 0
												41.23 1
												41.23 2
50009	1.000	9	1554	-75635.8	1317.60	1292.67	-2.85	-0.86	1.50	1.15	7.00	4.52 3
												0.76 T <sup>1</sup>
												15.84 0
												41.23 1
50010	0.000	9	1554	-75635.8	1317.62	1292.68	-2.85	-0.86	1.50	1.15	7.00	41.23 2
												15.84 0
												41.23 1
												4.52 3
50010	1.000	9	1554	-73039.4	2118.20	1109.73	-3.04	-0.61	1.50	1.15	6.72	0.76 T <sup>1</sup>
												15.84 0
												41.23 1
												41.23 2
50011	0.000	9	1554	-73039.3	2118.21	1109.75	-3.04	-0.61	1.50	1.15	6.72	4.52 3
												0.76 T <sup>1</sup>
												15.84 0
												41.23 1
50011	1.000	9	1554	-70645.7	2849.74	940.75	-3.19	-0.41	1.50	1.15	6.45	41.23 2
												15.84 0
												41.23 1
												4.52 3
50012	0.000	9	1554	-70645.6	2849.75	940.74	-3.19	-0.41	1.50	1.15	6.45	0.76 T <sup>1</sup>
												15.84 0
												41.23 1
												41.23 2
50012	1.000	9	1554	-68447.4	3518.37	785.02	-3.31	-0.25	1.50	1.15	6.21	4.52 3
												0.76 T <sup>1</sup>
												15.84 0
												41.23 1
50013	0.000	9	1554	-68447.4	3518.38	785.05	-3.31	-0.25	1.50	1.15	6.21	41.23 2
												15.84 0
												41.23 1
												4.52 3
50013	1.000	9	1554	-66439.1	4128.69	639.83	-3.41	-0.12	1.50	1.15	5.99	0.76 T <sup>1</sup>
												15.84 0
												41.23 1
												41.23 2
50013	1.000	9	1554	-66439.1	4128.69	639.83	-3.41	-0.12	1.50	1.15	5.99	4.52 3
												0.76 T <sup>1</sup>
												15.84 0
												41.23 2

Røydalen\_NORD\_GSR

**Required Reinforcements**

Beam	x[m]	SNo	LC	NRd [kN]	MyRd [kNm]	MzRd [kNm]	ε-1 [o/oo]	ε-2 [o/oo]	γ-c [-]	γ-s [-]	rel [-]	As Lay. [cm <sup>2</sup> ]	
50014	0.000	9	1554	-66439.1	4128.69	639.84	-3.41	-0.12	1.50	1.15	5.99	15.84 0	
												41.23 1	
												41.23 2	
												4.52 3	
	1.000	9	1554	-64603.8	4686.12	508.03	-3.50	-0.44	1.50	1.15	5.78	0.75 T <sup>1</sup>	
												15.84 0	
												41.23 1	
												41.23 2	
	50015	0.000	9	1554	-64603.8	4686.12	508.03	-3.50	-0.44	1.50	1.15	5.78	15.84 0
													41.23 1
													41.23 2
													4.52 3
1.000	9	1554	-62816.1	5186.03	377.28	-3.50	-0.37	1.50	1.15	5.59	0.75 T <sup>1</sup>		
											15.84 0		
											41.23 1		
											41.23 2		
50016	0.000	9	1554	-62816.1	5186.02	377.29	-3.50	-0.37	1.50	1.15	5.59	15.84 0	
												41.23 1	
												41.23 2	
												4.52 3	
	1.000	9	1554	-61126.8	5629.80	261.56	-3.50	-0.29	1.50	1.15	5.40	0.75 T <sup>1</sup>	
												15.84 0	
												41.23 1	
												41.23 2	
	50017	0.000	9	1554	-61126.8	5629.79	261.60	-3.50	-0.29	1.50	1.15	5.40	15.84 0
													41.23 1
													41.23 2
													4.52 3
1.000	9	1554	-59522.0	6024.10	150.46	-3.50	-0.21	1.50	1.15	5.22	0.75 T <sup>1</sup>		
											15.84 0		
											41.23 1		
											41.23 2		
50018	0.000	9	1554	-50830.7	-7624.33	1924.67	-3.50	0.43	1.50	1.15	5.31	15.84 0	
												45.63 1	
												41.23 2	
												4.52 3	
	1.000	9	1554	-52582.8	-7346.95	1917.49	-3.50	0.31	1.50	1.15	5.45	0.35 T <sup>1</sup>	
												15.84 0	
												45.64 1	
												41.23 2	
	50019	0.000	9	1554	-52583.0	-7346.92	1917.54	-3.50	0.31	1.50	1.15	5.45	15.84 0
													45.64 1
													41.23 2
													4.52 3

Røydalen\_NORD\_GSR

Required Reinforcements

Beam	x[m]	SNo	LC	NRd [kN]	MyRd [kNm]	MzRd [kNm]	ε-1 [o/oo]	ε-2 [o/oo]	γ-c [-]	γ-s [-]	rel [-]	As Lay. [cm <sup>2</sup> ]
	1.000	9	1554	-54485.5	-7035.15	1918.13	-3.50	0.19	1.50	1.15	5.61	0.36 T <sup>1</sup> 15.84 0 44.58 1 42.31 2 4.52 3
50020	0.000	9	1554	-54485.8	-7035.20	1918.12	-3.50	0.19	1.50	1.15	5.61	0.36 T <sup>1</sup> 15.84 0 44.58 1 42.32 2 4.52 3
	1.000	9	1554	-56300.3	-6659.87	1909.51	-3.50	0.08	1.50	1.15	5.75	0.36 T <sup>1</sup> 15.84 0 41.23 1 41.23 2 4.52 3
50021	0.000	9	1554	-56300.1	-6659.91	1909.51	-3.50	0.08	1.50	1.15	5.75	0.36 T <sup>1</sup> 15.84 0 41.23 1 41.23 2 4.52 3
	1.000	9	1554	-58235.0	-6249.04	1901.77	-3.50	-0.04	1.50	1.15	5.91	0.37 T <sup>1</sup> 15.84 0 41.23 1 41.23 2 4.52 3
50022	0.000	9	1554	-58235.0	-6249.04	1901.76	-3.50	-0.04	1.50	1.15	5.91	0.37 T <sup>1</sup> 15.84 0 41.23 1 41.23 2 4.52 3
	1.000	9	1554	-60231.8	-5785.36	1889.92	-3.50	-0.14	1.50	1.15	6.06	0.38 T <sup>1</sup> 15.84 0 41.23 1 41.23 2 4.52 3
50023	0.000	9	1554	-60231.7	-5785.38	1889.92	-3.50	-0.14	1.50	1.15	6.06	0.38 T <sup>1</sup> 15.84 0 41.23 1 41.23 2 4.52 3
	1.000	9	1554	-62262.4	-5272.53	1874.47	-3.50	-0.25	1.50	1.15	6.22	0.38 T <sup>1</sup> 15.84 0 41.23 1 41.23 2 4.52 3
50024	0.000	9	1554	-62262.4	-5272.54	1874.47	-3.50	-0.25	1.50	1.15	6.22	0.38 T <sup>1</sup> 15.84 0 41.23 1 41.23 2 4.52 3 0.38 T <sup>1</sup>



Røydalen\_NORD\_GSR

**Required Reinforcements**

Beam	x[m]	SNo	LC	NRd [kN]	MyRd [kNm]	MzRd [kNm]	ε-1 [o/oo]	ε-2 [o/oo]	γ-c [-]	γ-s [-]	rel [-]	As Lay. [cm <sup>2</sup> ]
50024	1.000	9	1554	-64343.3	-4709.34	1856.26	-3.50	-0.35	1.50	1.15	6.38	15.84 0
												41.23 1
												41.23 2
												4.52 3
50025	0.000	9	1554	-64343.3	-4709.34	1856.27	-3.50	-0.35	1.50	1.15	6.38	15.84 0
												41.23 1
												41.23 2
												4.52 3
50025	1.000	9	1554	-66480.1	-4096.38	1832.26	-3.47	-0.04	1.50	1.15	6.54	0.38 T <sup>1</sup>
												15.84 0
												41.23 1
												41.23 2
50026	0.000	9	1554	-66480.1	-4096.39	1832.22	-3.47	-0.04	1.50	1.15	6.54	4.52 3
												0.39 T <sup>1</sup>
												15.84 0
												41.23 1
50026	1.000	9	1554	-68664.1	-3432.98	1807.32	-3.35	-0.19	1.50	1.15	6.71	41.23 2
												4.52 3
												0.39 T <sup>1</sup>
												15.84 0
50027	0.000	9	1554	-68664.1	-3432.98	1807.34	-3.35	-0.19	1.50	1.15	6.71	41.23 1
												41.23 2
												4.52 3
												0.39 T <sup>1</sup>
50027	1.000	9	1554	-70994.4	-2723.03	1782.59	-3.22	-0.38	1.50	1.15	6.89	15.84 0
												41.23 1
												41.23 2
												4.52 3
50028	0.000	9	1554	-70994.4	-2723.03	1782.58	-3.22	-0.38	1.50	1.15	6.89	0.39 T <sup>1</sup>
												15.84 0
												41.23 1
												41.23 2
50028	1.000	9	1554	-73474.3	-1964.71	1755.28	-3.05	-0.60	1.50	1.15	7.08	4.52 3
												0.39 T <sup>1</sup>
												15.84 0
												41.23 1
50029	0.000	9	1554	-73474.3	-1964.75	1755.28	-3.05	-0.60	1.50	1.15	7.08	41.23 2
												4.52 3
												0.39 T <sup>1</sup>
												15.84 0
50029	1.000	9	1554	-76088.7	-1155.65	1726.73	-2.84	-0.87	1.50	1.15	7.28	41.23 1
												41.23 2
												4.52 3
												0.39 T <sup>1</sup>

Røydalen\_NORD\_GSR

Required Reinforcements

Beam	x[m]	SNo	LC	NRd [kN]	MyRd [kNm]	MzRd [kNm]	ε-1 [o/oo]	ε-2 [o/oo]	γ-c [-]	γ-s [-]	rel [-]	As [cm <sup>2</sup> ]	Lay.
50030	0.000	9	1554	-76088.8	-1155.63	1726.74	-2.84	-0.87	1.50	1.15	7.28	0.39	T <sup>1</sup>
												15.84	0
												41.23	1
												41.23	2
												4.52	3
												0.39	T <sup>1</sup>
1.000	9	1554	1554	-78390.6	-288.77	1687.31	-2.53	-1.29	1.50	1.15	7.44	15.84	0
												41.23	1
												41.23	2
												4.52	3
50031	0.000	9	1554	-78390.6	-288.76	1687.30	-2.53	-1.29	1.50	1.15	7.44	0.39	T <sup>1</sup>
												15.84	0
												41.23	1
												41.23	2
												4.52	3
												0.39	T <sup>1</sup>
1.000	9	1554	1554	-77782.1	595.02	1581.90	-2.65	-1.14	1.50	1.15	7.34	15.84	0
												41.23	1
												41.23	2
												4.52	3
50032	0.000	9	1554	-77782.1	595.03	1581.88	-2.65	-1.14	1.50	1.15	7.34	0.39	T <sup>1</sup>
												15.84	0
												41.23	1
												41.23	2
												4.52	3
												0.39	T <sup>1</sup>
1.000	9	1554	1554	-75290.0	1418.00	1445.28	-2.89	-0.81	1.50	1.15	7.05	15.84	0
												41.23	1
												41.23	2
												4.52	3
50033	0.000	9	1554	-75290.0	1418.02	1445.27	-2.89	-0.81	1.50	1.15	7.05	0.39	T <sup>1</sup>
												15.84	0
												41.23	1
												41.23	2
												4.52	3
												0.39	T <sup>1</sup>
1.000	9	1554	1554	-72845.8	2171.55	1313.91	-3.07	-0.57	1.50	1.15	6.78	15.84	0
												41.23	1
												41.23	2
												4.52	3
50034	0.000	9	1554	-72845.8	2171.55	1313.91	-3.07	-0.57	1.50	1.15	6.78	0.39	T <sup>1</sup>
												15.84	0
												41.23	1
												41.23	2
												4.52	3
												0.39	T <sup>1</sup>
1.000	9	1554	1554	-70578.9	2865.23	1192.93	-3.21	-0.39	1.50	1.15	6.52	15.84	0
												41.23	1
												41.23	2
												4.52	3
												0.39	T <sup>1</sup>

Røydalen\_NORD\_GSR

**Required Reinforcements**

Beam	x[m]	SNo	LC	NRd [kN]	MyRd [kNm]	MzRd [kNm]	ε-1 [o/oo]	ε-2 [o/oo]	γ-c [-]	γ-s [-]	rel [-]	As [cm <sup>2</sup> ]	Lay.
50035	0.000	9	1554	-70578.9	2865.23	1192.92	-3.21	-0.39	1.50	1.15	6.52	15.84	0
												41.23	1
												41.23	2
												4.52	3
1.000	9	1554	-68498.9	3498.10	1080.49	-3.32	-0.23	1.50	1.15	6.28	0.39	T <sup>1</sup>	
											15.84	0	
											41.23	1	
											41.23	2	
50036	0.000	9	1554	-68498.9	3498.10	1080.49	-3.32	-0.23	1.50	1.15	6.28	15.84	0
												41.23	1
												41.23	2
												4.52	3
1.000	9	1554	-66584.2	4080.03	975.89	-3.42	-0.10	1.50	1.15	6.07	0.39	T <sup>1</sup>	
											15.84	0	
											41.23	1	
											41.23	2	
50037	0.000	9	1554	-66584.3	4080.02	975.89	-3.42	-0.10	1.50	1.15	6.07	15.84	0
												41.23	1
												41.23	2
												4.52	3
1.000	9	1554	-64822.4	4612.08	880.67	-3.50	-0.43	1.50	1.15	5.87	0.39	T <sup>1</sup>	
											15.84	0	
											41.23	1	
											41.23	2	
50038	0.000	9	1554	-64822.4	4612.08	880.69	-3.50	-0.43	1.50	1.15	5.87	15.84	0
												41.23	1
												41.23	2
												4.52	3
1.000	9	1554	-63118.1	5089.78	788.30	-3.50	-0.36	1.50	1.15	5.67	0.38	T <sup>1</sup>	
											15.84	0	
											41.23	1	
											41.23	2	
50039	0.000	9	1554	-63118.1	5089.77	788.31	-3.50	-0.36	1.50	1.15	5.67	15.84	0
												41.23	1
												41.23	2
												4.52	3
1.000	9	1554	-61505.7	5518.84	701.64	-3.50	-0.28	1.50	1.15	5.49	0.38	T <sup>1</sup>	
											15.84	0	
											41.23	1	
											41.23	2	
50040	0.000	9	1554	-61505.8	5518.83	701.64	-3.50	-0.28	1.50	1.15	5.49	15.84	0
												41.23	1
												41.23	2
												4.52	3

Røydalen\_NORD\_GSR

Required Reinforcements

Beam	x[m]	SNo	LC	NRd [kN]	MyRd [kNm]	MzRd [kNm]	ε-1 [o/oo]	ε-2 [o/oo]	γ-c [-]	γ-s [-]	rel [-]	As [cm <sup>2</sup> ]	Lay.
	1.000	9	1554	-59969.3	5902.73	619.67	-3.50	-0.21	1.50	1.15	5.32	0.38 T <sup>1</sup>	15.84 0
												41.23 1	41.23 2
												4.52 3	0.38 T <sup>1</sup>
50041	0.000	9	1554	-59969.3	5902.73	619.67	-3.50	-0.21	1.50	1.15	5.32	15.84 0	41.23 1
												41.23 2	4.52 3
	1.000	9	1554	-58520.9	6242.47	540.87	-3.50	-0.13	1.50	1.15	5.16	0.38 T <sup>1</sup>	15.84 0
												41.23 1	41.23 2
												4.52 3	0.38 T <sup>1</sup>
50042	0.000	9	1554	-58521.0	6242.46	540.88	-3.50	-0.13	1.50	1.15	5.16	15.84 0	41.23 1
												41.23 2	4.52 3
	1.000	9	1554	-57168.8	6540.32	467.54	-3.50	-0.06	1.50	1.15	5.01	0.38 T <sup>1</sup>	15.84 0
												41.23 1	41.23 2
												4.52 3	0.38 T <sup>1</sup>
50043	0.000	9	1554	-57168.9	6540.31	467.56	-3.50	-0.06	1.50	1.15	5.01	15.84 0	41.23 1
												41.23 2	4.52 3
	1.000	9	1554	-55916.6	6799.60	402.22	-3.50	0.01	1.50	1.15	4.86	0.37 T <sup>1</sup>	15.84 0
												41.23 1	41.23 2
												4.52 3	0.37 T <sup>1</sup>
50044	0.000	9	1554	-45494.5	-8301.51	1607.85	-3.50	0.82	1.50	1.15	4.61	15.84 0	44.38 1
												41.23 2	4.52 3
	1.000	9	1554	-47503.1	-8080.99	1637.80	-3.50	0.66	1.50	1.15	4.77	0.04 T <sup>1</sup>	15.84 0
												44.30 1	41.23 2
												4.52 3	0.04 T <sup>1</sup>
50045	0.000	9	1554	-47503.0	-8081.00	1637.78	-3.50	0.66	1.50	1.15	4.77	15.84 0	44.30 1
												41.23 2	4.52 3
												0.03 T <sup>1</sup>	

Røydalen\_NORD\_GSR

**Required Reinforcements**

Beam	x[m]	SNo	LC	NRd [kN]	MyRd [kNm]	MzRd [kNm]	ε-1 [o/oo]	ε-2 [o/oo]	γ-c [-]	γ-s [-]	rel [-]	As Lay. [cm <sup>2</sup> ]
50045	1.000	9	1554	-49615.6	-7809.92	1666.92	-3.50	0.50	1.50	1.15	4.95	15.84 0
												44.47 1
												41.23 2
												4.52 3
50046	0.000	9	1554	-49615.4	-7809.94	1666.94	-3.50	0.50	1.50	1.15	4.95	15.84 0
												44.48 1
												41.23 2
												4.52 3
50046	1.000	9	1554	-51817.9	-7482.01	1696.46	-3.50	0.35	1.50	1.15	5.13	0.03 T <sup>1</sup>
												15.84 0
												45.15 1
												41.23 2
50047	0.000	9	1554	-51817.7	-7482.03	1696.45	-3.50	0.35	1.50	1.15	5.13	4.52 3
												0.03 T <sup>1</sup>
												15.84 0
												45.15 1
50047	1.000	9	1554	-54101.5	-7091.27	1728.59	-3.50	0.20	1.50	1.15	5.32	41.23 2
												0.02 T <sup>1</sup>
												15.84 0
												45.25 1
50048	0.000	9	1554	-54101.5	-7091.29	1728.61	-3.50	0.20	1.50	1.15	5.32	41.23 2
												0.02 T <sup>1</sup>
												15.84 0
												45.25 1
50048	1.000	9	1554	-56453.7	-6636.12	1755.23	-3.50	0.06	1.50	1.15	5.51	4.52 3
												0.01 T <sup>1</sup>
												15.84 0
												41.23 1
50049	0.000	9	1554	-56453.6	-6636.17	1755.23	-3.50	0.06	1.50	1.15	5.51	41.23 2
												0.01 T <sup>1</sup>
												15.84 0
												41.23 1
50049	1.000	9	1554	-58869.5	-6111.94	1780.38	-3.50	-0.08	1.50	1.15	5.70	4.52 3
												0.01 T <sup>1</sup>
												15.84 0
												41.23 1
50050	0.000	9	1554	-58869.4	-6111.95	1780.39	-3.50	-0.08	1.50	1.15	5.70	41.23 2
												0.01 T <sup>1</sup>
												15.84 0
												41.23 1
50050	1.000	9	1554	-61329.2	-5517.15	1805.03	-3.50	-0.20	1.50	1.15	5.90	4.52 3
												0.01 T <sup>1</sup>
												15.84 0
												41.23 1
50051	0.000	9	1554	-61329.2	-5517.16	1805.04	-3.50	-0.20	1.50	1.15	5.90	41.23 2
												0.01 T <sup>1</sup>
												15.84 0
												41.23 1

Røydalen\_NORD\_GSR

**Required Reinforcements**

Beam	x[m]	SNo	LC	NRd [kN]	MyRd [kNm]	MzRd [kNm]	ε-1 [o/oo]	ε-2 [o/oo]	γ-c [-]	γ-s [-]	rel [-]	As Lay. [cm <sup>2</sup> ]
	1.000	9	1554	-63840.8	-4849.72	1825.63	-3.50	-0.32	1.50	1.15	6.10	4.52 3
												15.84 0
												41.23 1
												41.23 2
												4.52 3
50052	0.000	9	1554	-63840.8	-4849.73	1825.63	-3.50	-0.32	1.50	1.15	6.10	15.84 0
												41.23 1
												41.23 2
												4.52 3
	1.000	9	1554	-66427.8	-4112.09	1841.30	-3.47	-0.03	1.50	1.15	6.30	15.84 0
												41.23 1
												41.23 2
												4.52 3
50053	0.000	9	1554	-66427.7	-4112.09	1841.30	-3.47	-0.03	1.50	1.15	6.30	15.84 0
												41.23 1
												41.23 2
												4.52 3
	1.000	9	1554	-69085.5	-3303.26	1857.38	-3.33	-0.22	1.50	1.15	6.51	15.84 0
												41.23 1
												41.23 2
												4.52 3
50054	0.000	9	1554	-69085.5	-3303.25	1857.38	-3.33	-0.22	1.50	1.15	6.51	15.84 0
												41.23 1
												41.23 2
												4.52 3
	1.000	9	1554	-71951.5	-2427.46	1875.96	-3.16	-0.45	1.50	1.15	6.73	15.84 0
												41.23 1
												41.23 2
												4.52 3
50055	0.000	9	1554	-71951.6	-2427.46	1875.97	-3.16	-0.45	1.50	1.15	6.73	15.84 0
												41.23 1
												41.23 2
												4.52 3
	1.000	9	1554	-75017.8	-1481.77	1897.81	-2.95	-0.74	1.50	1.15	6.97	15.84 0
												41.23 1
												41.23 2
												4.52 3
50056	0.000	9	1554	-75017.8	-1481.76	1897.80	-2.95	-0.74	1.50	1.15	6.97	15.84 0
												41.23 1
												41.23 2
												4.52 3
	1.000	9	1554	-77964.6	-451.01	1908.90	-2.62	-1.17	1.50	1.15	7.19	15.84 0
												41.23 1
												41.23 2
												4.52 3
50057	0.000	9	1554	-77964.6	-450.99	1908.91	-2.62	-1.17	1.50	1.15	7.19	15.84 0
												41.23 1
												41.23 2
												4.52 3
	1.000	9	1554	-77616.1	618.70	1835.47	-2.68	-1.09	1.50	1.15	7.11	15.84 0
												41.23 1
												41.23 2
												4.52 3

Røydalen\_NORD\_GSR

**Required Reinforcements**

Beam	x[m]	SNo	LC	NRd [kN]	MyRd [kNm]	MzRd [kNm]	ε-1 [o/oo]	ε-2 [o/oo]	γ-c [-]	γ-s [-]	rel [-]	As [cm2]	Lay.
50058	0.000	9	1554	-77616.1	618.69	1835.43	-2.68	-1.09	1.50	1.15	7.11	15.84	0
												41.23	1
												41.23	2
												4.52	3
50059	0.000	9	1554	-74630.5	1610.67	1705.93	-2.96	-0.71	1.50	1.15	6.79	15.84	0
												41.23	1
												41.23	2
												4.52	3
50059	1.000	9	1554	-74630.5	1610.67	1705.93	-2.96	-0.71	1.50	1.15	6.79	15.84	0
												41.23	1
												41.23	2
												4.52	3
50059	0.000	9	1554	-74630.5	1610.68	1705.94	-2.96	-0.71	1.50	1.15	6.79	15.84	0
												41.23	1
												41.23	2
												4.52	3
50059	1.000	9	1554	-71721.5	2506.98	1581.18	-3.16	-0.45	1.50	1.15	6.48	15.84	0
												41.23	1
												41.23	2
												4.52	3
50060	0.000	9	1554	-71721.5	2506.99	1581.18	-3.16	-0.45	1.50	1.15	6.48	15.84	0
												41.23	1
												41.23	2
												4.52	3
50060	1.000	9	1554	-69073.2	3316.73	1469.59	-3.31	-0.25	1.50	1.15	6.20	15.84	0
												41.23	1
												41.23	2
												4.52	3
50061	0.000	9	1554	-69073.2	3316.73	1469.57	-3.31	-0.25	1.50	1.15	6.20	15.84	0
												41.23	1
												41.23	2
												4.52	3
50061	1.000	9	1554	-66651.8	4053.20	1365.71	-3.44	-0.08	1.50	1.15	5.95	15.84	0
												41.23	1
												41.23	2
												4.52	3
50062	0.000	9	1554	-66651.8	4053.20	1365.72	-3.44	-0.08	1.50	1.15	5.95	15.84	0
												41.23	1
												41.23	2
												4.52	3
50062	1.000	9	1554	-64404.7	4715.55	1272.66	-3.50	-0.39	1.50	1.15	5.71	15.84	0
												41.23	1
												41.23	2
												4.52	3
50063	0.000	9	1554	-64404.7	4715.55	1272.66	-3.50	-0.39	1.50	1.15	5.71	15.84	0
												41.23	1
												41.23	2
												4.52	3
50063	1.000	9	1554	-62251.2	5306.64	1182.26	-3.50	-0.29	1.50	1.15	5.48	15.84	0
												41.23	1
												41.23	2
												4.52	3
50064	0.000	9	1554	-62251.3	5306.63	1182.23	-3.50	-0.29	1.50	1.15	5.48	15.84	0
												41.23	1
												41.23	2
												4.52	3

Røydalen\_NORD\_GSR

Required Reinforcements

Beam	x[m]	SNo	LC	NRd [kN]	MyRd [kNm]	MzRd [kNm]	ε-1 [o/oo]	ε-2 [o/oo]	γ-c [-]	γ-s [-]	rel [-]	As [cm2]	Lay.
50064	1.000	9	1554	-60198.1	5829.81	1096.96	-3.50	-0.19	1.50	1.15	5.27	15.84	0
												41.23	1
												41.23	2
												4.52	3
50065	0.000	9	1554	-60198.1	5829.79	1096.97	-3.50	-0.19	1.50	1.15	5.27	15.84	0
												41.23	1
												41.23	2
												4.52	3
	1.000	9	1554	-58237.6	6288.86	1014.86	-3.50	-0.09	1.50	1.15	5.06	15.84	0
												41.23	1
												41.23	2
												4.52	3
50066	0.000	9	1554	-58237.6	6288.85	1014.87	-3.50	-0.09	1.50	1.15	5.06	15.84	0
												41.23	1
												41.23	2
												4.52	3
	1.000	9	1554	-56391.0	6684.66	941.30	-3.50	0.02	1.50	1.15	4.87	0.01	T <sup>1</sup>
												15.84	0
												41.23	1
												41.23	2
50067	0.000	9	1554	-56391.1	6684.65	941.28	-3.50	0.02	1.50	1.15	4.87	15.84	0
												41.23	1
												41.23	2
												4.52	3
	1.000	9	1554	-54664.6	7030.09	869.07	-3.50	0.12	1.50	1.15	4.69	0.02	T <sup>1</sup>
												15.84	0
												41.50	1
												43.05	2
50068	0.000	9	1554	-54664.8	7030.04	869.07	-3.50	0.12	1.50	1.15	4.69	15.84	0
												41.50	1
												43.05	2
												4.52	3
	1.000	9	1554	-53036.9	7323.38	805.68	-3.50	0.22	1.50	1.15	4.52	0.02	T <sup>1</sup>
												15.84	0
												41.53	1
												42.86	2
50069	0.000	9	1554	-53037.2	7323.34	805.70	-3.50	0.22	1.50	1.15	4.52	15.84	0
												41.53	1
												42.86	2
												4.52	3
	1.000	9	1554	-51526.2	7571.46	744.99	-3.50	0.32	1.50	1.15	4.37	0.02	T <sup>1</sup>
												15.84	0
												41.51	1
												42.73	2
												4.52	3
												0.02	T <sup>1</sup>



Røydalen\_NORD\_GSR

**Required Reinforcements**

Beam	x[m]	SNo	LC	NRd [kN]	MyRd [kNm]	MzRd [kNm]	ε-1 [o/oo]	ε-2 [o/oo]	γ-c [-]	γ-s [-]	rel [-]	As Lay. [cm <sup>2</sup> ]	
50070	0.000	9	1554	-51526.0	7571.43	744.97	-3.50	0.32	1.50	1.15	4.37	15.84 0	
												41.51 1	
												42.73 2	
												4.52 3	
	1.000	9	1554	-50112.3	7776.00	687.64	-3.50	0.42	1.50	1.15	4.22	0.03 T <sup>1</sup>	
												15.84 0	
												41.23 1	
												41.23 2	
	50071	0.000	9	1554	-38615.3	-8801.49	1286.57	-3.50	1.47	1.50	1.15	4.04	15.84 0
													44.04 1
													41.23 2
													4.52 3
1.000	9	1554	-40931.2	-8680.26	1326.57	-3.50	1.23	1.50	1.15	4.24	0.42 T <sup>1</sup>		
											15.84 0		
											44.18 1		
											41.23 2		
50072	0.000	9	1554	-40930.9	-8680.26	1326.59	-3.50	1.23	1.50	1.15	4.24	15.84 0	
												44.18 1	
												41.23 2	
												4.52 3	
	1.000	9	1554	-43423.8	-8499.32	1368.10	-3.50	0.99	1.50	1.15	4.47	0.41 T <sup>1</sup>	
												15.84 0	
												44.00 1	
												41.23 2	
	50073	0.000	9	1554	-43423.4	-8499.36	1368.12	-3.50	0.99	1.50	1.15	4.47	15.84 0
													44.00 1
													41.23 2
													4.52 3
1.000	9	1554	-46081.6	-8248.49	1410.30	-3.50	0.76	1.50	1.15	4.71	0.40 T <sup>1</sup>		
											15.84 0		
											43.79 1		
											41.23 2		
50074	0.000	9	1554	-46081.5	-8248.50	1410.32	-3.50	0.76	1.50	1.15	4.71	15.84 0	
												43.79 1	
												41.23 2	
												4.52 3	
1.000	9	1554	-48887.6	-7916.12	1451.98	-3.50	0.54	1.50	1.15	4.96	0.39 T <sup>1</sup>		
											15.84 0		
											43.81 1		
											41.23 2		
50075	0.000	9	1554	-48887.6	-7916.13	1452.01	-3.50	0.54	1.50	1.15	4.96	15.84 0	
												43.81 1	
												41.23 2	
												4.52 3	

Røydalen\_NORD\_GSR

**Required Reinforcements**

Beam	x[m]	SNo	LC	NRd [kN]	MyRd [kNm]	MzRd [kNm]	ε-1 [o/oo]	ε-2 [o/oo]	γ-c [-]	γ-s [-]	rel [-]	As [cm <sup>2</sup> ]	Lay.
	1.000	9	1554	-51812.7	-7491.67	1495.58	-3.50	0.34	1.50	1.15	5.21	0.39 T <sup>1</sup>	15.84 0
												44.71 1	41.23 2
												4.52 3	0.39 T <sup>1</sup>
50076	0.000	9	1554	-51812.5	-7491.70	1495.60	-3.50	0.34	1.50	1.15	5.21	15.84 0	44.71 1
												41.23 2	4.52 3
	1.000	9	1554	-54897.0	-6973.99	1534.82	-3.50	0.14	1.50	1.15	5.48	0.38 T <sup>1</sup>	15.84 0
												43.86 1	42.21 2
												4.52 3	0.38 T <sup>1</sup>
50077	0.000	9	1554	-54897.0	-6973.98	1534.83	-3.50	0.14	1.50	1.15	5.48	15.84 0	43.86 1
												42.21 2	4.52 3
	1.000	9	1554	-57919.1	-6334.82	1568.57	-3.50	-0.04	1.50	1.15	5.74	0.38 T <sup>1</sup>	15.84 0
												41.23 1	41.23 2
												4.52 3	0.38 T <sup>1</sup>
50078	0.000	9	1554	-57919.0	-6334.84	1568.58	-3.50	-0.04	1.50	1.15	5.74	15.84 0	41.23 1
												41.23 2	4.52 3
	1.000	9	1554	-61081.6	-5589.60	1603.60	-3.50	-0.20	1.50	1.15	6.01	0.37 T <sup>1</sup>	15.84 0
												41.23 1	41.23 2
												4.52 3	0.37 T <sup>1</sup>
50079	0.000	9	1554	-61081.6	-5589.60	1603.63	-3.50	-0.20	1.50	1.15	6.01	15.84 0	41.23 1
												41.23 2	4.52 3
	1.000	9	1554	-64292.7	-4732.71	1632.46	-3.50	-0.36	1.50	1.15	6.28	0.37 T <sup>1</sup>	15.84 0
												41.23 1	41.23 2
												4.52 3	0.37 T <sup>1</sup>
50080	0.000	9	1554	-64292.6	-4732.71	1632.47	-3.50	-0.36	1.50	1.15	6.28	15.84 0	41.23 1
												41.23 2	4.52 3
												0.37 T <sup>1</sup>	

Røydalen\_NORD\_GSR

**Required Reinforcements**

Beam	x[m]	SNo	LC	NRd [kN]	MyRd [kNm]	MzRd [kNm]	ε-1 [o/oo]	ε-2 [o/oo]	γ-c [-]	γ-s [-]	rel [-]	As Lay. [cm <sup>2</sup> ]
50080	1.000	9	1554	-67582.9	-3765.26	1655.20	-3.40	-0.13	1.50	1.15	6.55	15.84 0
												41.23 1
												41.23 2
												4.52 3
												0.37 T <sup>1</sup>
50081	0.000	9	1554	-67583.0	-3765.25	1655.22	-3.40	-0.13	1.50	1.15	6.56	15.84 0
												41.23 1
												41.23 2
												4.52 3
												0.37 T <sup>1</sup>
	1.000	9	1554	-71106.6	-2691.73	1681.39	-3.20	-0.39	1.50	1.15	6.85	15.84 0
												41.23 1
												41.23 2
												4.52 3
												0.37 T <sup>1</sup>
50082	0.000	9	1554	-71106.7	-2691.72	1681.40	-3.20	-0.39	1.50	1.15	6.85	15.84 0
												41.23 1
												41.23 2
												4.52 3
												0.36 T <sup>1</sup>
	1.000	9	1554	-74959.0	-1508.83	1711.75	-2.94	-0.75	1.50	1.15	7.17	15.84 0
												41.23 1
												41.23 2
												4.52 3
												0.36 T <sup>1</sup>
50083	0.000	9	1554	-74959.1	-1508.80	1711.71	-2.94	-0.75	1.50	1.15	7.17	15.84 0
												41.23 1
												41.23 2
												4.52 3
												0.36 T <sup>1</sup>
	1.000	9	1554	-78492.5	-192.86	1722.62	-2.49	-1.35	1.50	1.15	7.45	15.84 0
												41.23 1
												41.23 2
												4.52 3
												0.36 T <sup>1</sup>
50084	0.000	9	1554	-78492.4	-192.90	1722.69	-2.49	-1.35	1.50	1.15	7.45	15.84 0
												41.23 1
												41.23 2
												4.52 3
												0.36 T <sup>1</sup>
	1.000	9	1554	-76168.9	1137.12	1609.59	-2.83	-0.90	1.50	1.15	7.18	15.84 0
												41.23 1
												41.23 2
												4.52 3
												0.36 T <sup>1</sup>
50085	0.000	9	1554	-76168.9	1137.14	1609.54	-2.83	-0.90	1.50	1.15	7.18	15.84 0
												41.23 1
												41.23 2
												4.52 3
												0.36 T <sup>1</sup>
	1.000	9	1554	-72334.2	2323.16	1470.59	-3.11	-0.52	1.50	1.15	6.77	15.84 0
												41.23 1
												41.23 2
												4.52 3

Røydalen\_NORD\_GSR

Required Reinforcements

Beam	x[m]	SNo	LC	NRd [kN]	MyRd [kNm]	MzRd [kNm]	ε-1 [o/oo]	ε-2 [o/oo]	γ-c [-]	γ-s [-]	rel [-]	As [cm <sup>2</sup> ]	Lay.
50086	0.000	9	1554	-72334.2	2323.16	1470.61	-3.11	-0.52	1.50	1.15	6.77	0.36	T <sup>1</sup>
												15.84	0
												41.23	1
												41.23	2
50086	1.000	9	1554	-68901.5	3371.31	1344.08	-3.32	-0.24	1.50	1.15	6.41	4.52	3
												0.37	T <sup>1</sup>
												15.84	0
												41.23	1
50087	0.000	9	1554	-68901.5	3371.31	1344.08	-3.32	-0.24	1.50	1.15	6.41	41.23	2
												4.52	3
												0.37	T <sup>1</sup>
												15.84	0
50087	1.000	9	1554	-65823.9	4306.44	1230.13	-3.47	-0.03	1.50	1.15	6.08	41.23	3
												0.37	T <sup>1</sup>
												15.84	0
												41.23	1
50088	0.000	9	1554	-65823.9	4306.44	1230.08	-3.47	-0.03	1.50	1.15	6.08	41.23	2
												4.52	3
												0.37	T <sup>1</sup>
												15.84	0
50088	1.000	9	1554	-62926.5	5128.55	1128.80	-3.50	-0.32	1.50	1.15	5.77	41.23	3
												0.37	T <sup>1</sup>
												15.84	0
												41.23	1
50089	0.000	9	1554	-62926.5	5128.54	1128.80	-3.50	-0.32	1.50	1.15	5.77	41.23	2
												4.52	3
												0.37	T <sup>1</sup>
												15.84	0
50089	1.000	9	1554	-60154.6	5842.93	1031.20	-3.50	-0.19	1.50	1.15	5.48	41.23	3
												0.37	T <sup>1</sup>
												15.84	0
												41.23	1
50090	0.000	9	1554	-60154.7	5842.91	1031.18	-3.50	-0.19	1.50	1.15	5.48	41.23	2
												4.52	3
												0.37	T <sup>1</sup>
												15.84	0
50090	1.000	9	1554	-57493.2	6454.47	937.73	-3.50	-0.05	1.50	1.15	5.20	41.23	3
												0.38	T <sup>1</sup>
												15.84	0
												41.23	1
50090	1.000	9	1554	-57493.2	6454.47	937.73	-3.50	-0.05	1.50	1.15	5.20	41.23	2
												4.52	3
												0.38	T <sup>1</sup>
												15.84	0

Røydalen\_NORD\_GSR

Required Reinforcements

Beam	x[m]	SNo	LC	NRd [kN]	MyRd [kNm]	MzRd [kNm]	ε-1 [o/oo]	ε-2 [o/oo]	γ-c [-]	γ-s [-]	rel [-]	As Lay. [cm <sup>2</sup> ]	
50091	0.000	9	1554	-57493.2	6454.47	937.70	-3.50	-0.05	1.50	1.15	5.20	15.84 0	
												41.23 1	
												41.23 2	
												4.52 3	
	1.000	9	1554	-55007.4	6973.12	853.84	-3.50	0.10	1.50	1.15	4.94	0.38 T <sup>1</sup>	
												15.84 0	
												41.82 1	
												42.70 2	
	50092	0.000	9	1554	-55008.1	6973.09	853.84	-3.50	0.10	1.50	1.15	4.94	4.52 3
													0.38 T <sup>1</sup>
													15.84 0
													41.82 1
1.000	9	1554	-52611.3	7402.97	776.90	-3.50	0.25	1.50	1.15	4.70	42.69 2		
											4.52 3		
											0.38 T <sup>1</sup>		
											15.84 0		
50093	0.000	9	1554	-52611.6	7402.91	776.86	-3.50	0.25	1.50	1.15	4.70	41.86 1	
												42.46 2	
												4.52 3	
												0.39 T <sup>1</sup>	
	1.000	9	1554	-50306.5	7747.75	704.63	-3.50	0.40	1.50	1.15	4.46	15.84 0	
												41.23 1	
												41.23 2	
												4.52 3	
	50094	0.000	9	1554	-50306.5	7747.74	704.65	-3.50	0.40	1.50	1.15	4.46	0.39 T <sup>1</sup>
													15.84 0
													41.23 1
													41.23 2
1.000	9	1554	-48215.1	8031.78	639.05	-3.50	0.56	1.50	1.15	4.25	4.52 3		
											0.39 T <sup>1</sup>		
											15.84 0		
											41.23 1		
50095	0.000	9	1554	-48215.3	8031.76	639.04	-3.50	0.56	1.50	1.15	4.25	42.58 2	
												4.52 3	
												0.40 T <sup>1</sup>	
												15.84 0	
	1.000	9	1554	-46272.9	8255.71	578.25	-3.50	0.71	1.50	1.15	4.05	41.23 1	
												41.73 2	
												4.52 3	
												0.40 T <sup>1</sup>	
	50096	0.000	9	1554	-46273.1	8255.69	578.25	-3.50	0.71	1.50	1.15	4.05	15.84 0
													41.23 1
													41.73 2
													4.52 3

Røydalen\_NORD\_GSR

Required Reinforcements

Beam	x[m]	SNo	LC	NRd [kN]	MyRd [kNm]	MzRd [kNm]	ε-1 [o/oo]	ε-2 [o/oo]	γ-c [-]	γ-s [-]	rel [-]	As [cm <sup>2</sup> ]	Lay.
	1.000	9	1554	-44513.2	8433.03	523.62	-3.50	0.86	1.50	1.15	3.87	0.40 T <sup>1</sup>	
												15.84 0	
												41.23 1	
												42.32 2	
												4.52 3	
												0.40 T <sup>1</sup>	
50097	0.000	9	1554	-44513.5	8433.00	523.59	-3.50	0.86	1.50	1.15	3.87	15.84 0	
												41.23 1	
												42.33 2	
												4.52 3	
												0.41 T <sup>1</sup>	
	1.000	9	1554	-42923.9	8568.76	472.69	-3.50	1.01	1.50	1.15	3.71	15.84 0	
												41.23 1	
												42.35 2	
												4.52 3	
												0.41 T <sup>1</sup>	
50098	0.000	9	1554	-27349.5	-8564.21	51.57	-3.50	3.28	1.50	1.15	2.48	15.84 0	
												41.36 1	
												41.23 2	
												4.52 3	
												0.50 T <sup>1</sup>	
	0.978	9	1554	-30560.1	-8832.94	72.86	-3.50	2.60	1.50	1.15	2.75	15.84 0	
												41.41 1	
												41.23 2	
												4.52 3	
												0.50 T <sup>1</sup>	
50099	0.000	9	1554	-30567.3	-8833.43	72.87	-3.50	2.60	1.50	1.15	2.75	15.84 0	
												41.41 1	
												41.23 2	
												4.52 3	
												0.50 T <sup>1</sup>	
	0.978	9	1554	-33981.3	-8952.93	102.01	-3.50	2.03	1.50	1.15	3.04	15.84 0	
												41.47 1	
												41.23 2	
												4.52 3	
												0.50 T <sup>1</sup>	
50100	0.000	9	1554	-33986.1	-8952.89	101.99	-3.50	2.03	1.50	1.15	3.04	15.84 0	
												41.47 1	
												41.23 2	
												4.52 3	
												0.49 T <sup>1</sup>	
	0.978	9	1554	-37477.7	-8877.08	132.10	-3.50	1.58	1.50	1.15	3.33	15.84 0	
												41.54 1	
												41.23 2	
												4.52 3	
												0.49 T <sup>1</sup>	
50101	0.000	9	1554	-37474.7	-8877.18	132.06	-3.50	1.58	1.50	1.15	3.33	15.84 0	
												41.54 1	
												41.23 2	
												4.52 3	
												0.49 T <sup>1</sup>	

Røydalen\_NORD\_GSR

**Required Reinforcements**

Beam	x[m]	SNo	LC	NRd [kN]	MyRd [kNm]	MzRd [kNm]	ε-1 [o/oo]	ε-2 [o/oo]	γ-c [-]	γ-s [-]	rel [-]	As Lay. [cm <sup>2</sup> ]
50101	0.978	9	1554	-41411.5	-8683.13	163.48	-3.50	1.14	1.50	1.15	3.66	15.84 0
												41.54 1
												41.23 2
												4.52 3
50102	0.000	9	1554	-41405.6	-8683.53	163.64	-3.50	1.14	1.50	1.15	3.66	15.84 0
												41.54 1
												41.23 2
												4.52 3
50102	0.978	9	1554	-45744.3	-8323.39	203.54	-3.50	0.74	1.50	1.15	4.02	0.49 T <sup>1</sup>
												15.84 0
												41.72 1
												41.23 2
50103	0.000	9	1554	-45744.1	-8323.41	203.57	-3.50	0.74	1.50	1.15	4.02	4.52 3
												0.49 T <sup>1</sup>
												15.84 0
												41.72 1
50103	0.978	9	1554	-50390.4	-7751.61	251.29	-3.50	0.37	1.50	1.15	4.40	41.23 2
												0.49 T <sup>1</sup>
												15.84 0
												41.84 1
50104	0.000	9	1554	-50392.0	-7751.38	251.31	-3.50	0.37	1.50	1.15	4.40	41.23 2
												0.49 T <sup>1</sup>
												15.84 0
												41.84 1
50104	0.978	9	1554	-55274.3	-6933.15	299.53	-3.50	0.05	1.50	1.15	4.79	4.52 3
												0.49 T <sup>1</sup>
												15.84 0
												41.77 1
50105	0.000	9	1554	-55274.0	-6933.18	299.50	-3.50	0.05	1.50	1.15	4.79	41.44 2
												0.49 T <sup>1</sup>
												15.84 0
												41.77 1
50105	0.978	9	1554	-60261.3	-5840.84	358.97	-3.50	-0.24	1.50	1.15	5.19	41.43 2
												0.49 T <sup>1</sup>
												15.84 0
												41.23 1
50106	0.000	9	1554	-60260.9	-5840.92	359.03	-3.50	-0.24	1.50	1.15	5.19	4.52 3
												0.49 T <sup>1</sup>
												15.84 0
												41.23 1
50106	0.978	9	1554	-65334.8	-4465.75	419.04	-3.46	-0.06	1.50	1.15	5.59	41.23 2
												0.49 T <sup>1</sup>
												15.84 0
												41.23 1
												4.52 3

Røydalen\_NORD\_GSR

**Required Reinforcements**

Beam	x[m]	SNo	LC	NRd [kN]	MyRd [kNm]	MzRd [kNm]	ε-1 [o/oo]	ε-2 [o/oo]	γ-c [-]	γ-s [-]	rel [-]	As [cm <sup>2</sup> ]	Lay.
50107	0.000	9	1554	-65334.8	-4465.77	419.00	-3.46	-0.06	1.50	1.15	5.59	0.49 T <sup>1</sup>	15.84 0
												41.23 1	
												41.23 2	
												4.52 3	
0.978	9	1554	-70768.2	-2819.54	485.51	-3.15	-0.46	1.50	1.15	6.02	0.49 T <sup>1</sup>	15.84 0	
											41.23 1		
											41.23 2		
											4.52 3		
50108	0.000	9	1554	-70768.2	-2819.54	485.51	-3.15	-0.46	1.50	1.15	6.02	0.49 T <sup>1</sup>	15.84 0
												41.23 1	
												41.23 2	
												4.52 3	
0.978	9	1554	-77124.3	-887.03	564.69	-2.65	-1.14	1.50	1.15	6.52	0.49 T <sup>1</sup>	15.84 0	
											41.23 1		
											41.23 2		
											4.52 3		
50109	0.000	9	1554	-77124.3	-887.04	564.68	-2.65	-1.14	1.50	1.15	6.52	0.49 T <sup>1</sup>	15.84 0
												41.23 1	
												41.23 2	
												4.52 3	
0.978	9	1554	-75898.5	1260.45	590.50	-2.77	-0.97	1.50	1.15	6.38	0.49 T <sup>1</sup>	15.84 0	
											41.23 1		
											41.23 2		
											4.52 3		
50110	0.000	9	1554	-75898.6	1260.44	590.51	-2.77	-0.97	1.50	1.15	6.38	0.49 T <sup>1</sup>	15.84 0
												41.23 1	
												41.23 2	
												4.52 3	
0.978	9	1554	-69851.6	3096.02	572.91	-3.22	-0.38	1.50	1.15	5.83	0.49 T <sup>1</sup>	15.84 0	
											41.23 1		
											41.23 2		
											4.52 3		
50111	0.000	9	1554	-69851.6	3096.00	572.86	-3.22	-0.38	1.50	1.15	5.83	0.49 T <sup>1</sup>	15.84 0
												41.23 1	
												41.23 2	
												4.52 3	
0.978	9	1554	-64767.4	4635.99	557.61	-3.49	-0.01	1.50	1.15	5.38	0.49 T <sup>1</sup>	15.84 0	
											41.23 1		
											41.23 2		
											4.52 3		
												0.49 T <sup>1</sup>	



Røydalen\_NORD\_GSR

Required Reinforcements

Beam	x[m]	SNo	LC	NRd [kN]	MyRd [kNm]	MzRd [kNm]	ε-1 [o/oo]	ε-2 [o/oo]	γ-c [-]	γ-s [-]	rel [-]	As Lay. [cm <sup>2</sup> ]
50112	0.000	9	1554	-64767.5	4635.94	557.60	-3.49	-0.01	1.50	1.15	5.38	15.84 0
												41.23 1
												41.23 2
												4.52 3
0.978	9	1554	-59997.4	5898.59	543.53	-3.50	-0.21	1.50	1.15	4.95	0.49 T <sup>1</sup>	
											15.84 0	
											41.23 1	
											41.23 2	
50113	0.000	9	1554	-59997.6	5898.53	543.53	-3.50	-0.21	1.50	1.15	4.95	15.84 0
												41.23 1
												41.23 2
												4.52 3
0.978	9	1554	-55453.3	6896.60	524.25	-3.50	0.05	1.50	1.15	4.55	0.49 T <sup>1</sup>	
											15.84 0	
											41.68 1	
											42.07 2	
50114	0.000	9	1554	-55454.0	6896.49	524.23	-3.50	0.05	1.50	1.15	4.55	4.52 3
												0.49 T <sup>1</sup>
												15.84 0
												41.68 1
0.978	9	1554	-51075.7	7642.88	503.96	-3.50	0.34	1.50	1.15	4.16	42.07 2	
											4.52 3	
											0.49 T <sup>1</sup>	
											15.84 0	
50115	0.000	9	1554	-51074.8	7643.02	503.95	-3.50	0.34	1.50	1.15	4.16	41.23 1
												42.44 2
												4.52 3
												0.49 T <sup>1</sup>
0.978	9	1554	-46989.4	8181.97	482.01	-3.50	0.65	1.50	1.15	3.81	15.84 0	
											41.23 1	
											42.27 2	
											4.52 3	
50116	0.000	9	1554	-46988.8	8182.03	481.99	-3.50	0.65	1.50	1.15	3.81	0.49 T <sup>1</sup>
												15.84 0
												41.23 1
												42.27 2
0.978	9	1554	-43233.0	8544.07	460.75	-3.50	0.98	1.50	1.15	3.48	4.52 3	
											0.50 T <sup>1</sup>	
											15.84 0	
											41.23 1	
50117	0.000	9	1554	-43235.5	8543.87	460.70	-3.50	0.98	1.50	1.15	3.48	42.17 2
												4.52 3
												0.50 T <sup>1</sup>
												15.84 0
0.978	9	1554	-43235.5	8543.87	460.70	-3.50	0.98	1.50	1.15	3.48	42.17 2	
											4.52 3	
											0.50 T <sup>1</sup>	
											15.84 0	

Røydalen\_NORD\_GSR

**Required Reinforcements**

Beam	x[m]	SNo	LC	NRd [kN]	MyRd [kNm]	MzRd [kNm]	ε-1 [o/oo]	ε-2 [o/oo]	γ-c [-]	γ-s [-]	rel [-]	As Lay. [cm2]
	0.978	9	1554	-39848.0	8768.35	441.80	-3.50	1.32	1.50	1.15	3.19	0.50 T <sup>1</sup> 15.84 0 41.23 1 42.27 2 4.52 3
50118	0.000	9	1554	-39851.9	8768.14	441.77	-3.50	1.32	1.50	1.15	3.19	0.50 T <sup>1</sup> 15.84 0 41.23 1 42.27 2 4.52 3
	0.978	9	1554	-36848.5	8887.73	421.48	-3.50	1.66	1.50	1.15	2.94	0.51 T <sup>1</sup> 15.84 0 41.23 1 41.89 2 4.52 3
50119	0.000	9	1554	-36849.8	8887.69	421.47	-3.50	1.66	1.50	1.15	2.94	0.51 T <sup>1</sup> 15.84 0 41.23 1 41.89 2 4.52 3
	0.978	9	1554	-34253.3	8937.88	406.04	-3.50	1.99	1.50	1.15	2.71	0.51 T <sup>1</sup> 15.84 0 41.23 1 41.69 2 4.52 3
50120	0.000	9	1554	-34251.3	8937.87	406.00	-3.50	1.99	1.50	1.15	2.71	0.51 T <sup>1</sup> 15.84 0 41.23 1 41.68 2 4.52 3
	0.978	9	1554	-31979.9	8923.24	391.40	-3.50	2.33	1.50	1.15	2.52	0.53 T <sup>1</sup> 15.84 0 41.23 1 42.19 2 4.52 3
												0.53 T <sup>1</sup>

<sup>1</sup> Torsional longitudinal reinforcement for 45° inclination, the layers will be checked and adjusted after the shear design

**Nonlinear Stresses**

**Parameters for Nonlinear Stresses**

Iteration only for normal force

Material of sections uses Serviceability strain-stress law with individual safety factors

Material of reinforcements uses Serviceability strain-stress law with individual safety factors

**Applied material properties**

Mat	Temp Lev.	Safety factor	Max.compr stress [MPa]	at strain [o/oo]	Max.tens stress [MPa]	at strain [o/oo]	Tension-stiffening [MPa]	Bond factor [-]
1	0	1.500	-35.33	-2.40	0.00	0.00	f <sub>c,t</sub> = 0.00	
2	0	1.150	-469.57	-50.00	469.57	50.00		
3	0	1.150	-1617.39	-60.00	1617.39	60.00		
4	0	1.500	-35.33	-2.40	0.00	0.00	f <sub>c,t</sub> = 0.00	
5	0	1.500	-35.33	-2.40	0.00	0.00	f <sub>c,t</sub> = 0.00	

Røydalen\_NORD\_GSR

**Nonlinear Stresses**

Beam	x[m]	SNo	LC	Ni	Myi	Mzi	yn	zn	σ-min	σ-s	σ-t	Ey-eff
				[kN]	[kNm]	[kNm]	[mm]	[mm]	[MPa]	[MPa]	[MPa]	[N/mm <sup>2</sup> ]
				ε-θ	ky	kz	fact	ε	σ-max	σ-s	σ-t	Ez-eff
				[o/oo]	[1/km]	[1/km]	[-]	[o/oo]	[MPa]	[MPa]	[MPa]	[N/mm <sup>2</sup> ]
50001	0.000	9	1554	-10135.4	-926.63	356.44	-28611	-653.8	-5.62	-41.10		25531
				-0.134	-0.204	0.005		-0.228	-0.99	-12.31		25370
	1.000	9	1554	-10209.6	-810.48	337.64	-30404	-752.4	-5.37	-39.59		25527
				-0.134	-0.179	0.004		-0.218	-1.29	-14.18		25365
50002	0.000	9	1554	-10209.6	-810.47	337.64	-30404	-752.4	-5.37	-39.59		25527
				-0.134	-0.179	0.004		-0.218	-1.29	-14.18		25365
	1.000	9	1554	-10283.7	-691.50	318.76	-32419	-887.7	-5.12	-38.04		25522
				-0.135	-0.152	0.004		-0.207	-1.60	-16.09		25359
50003	0.000	9	1554	-10283.7	-691.49	318.75	-32420	-887.7	-5.12	-38.04		25522
				-0.135	-0.152	0.004		-0.207	-1.60	-16.09		25359
	1.000	9	1554	-10357.9	-570.05	299.79	-34700	-1084	-4.86	-36.46		25516
				-0.136	-0.126	0.004		-0.196	-1.92	-18.05		25354
50004	0.000	9	1554	-10357.9	-570.05	299.79	-34700	-1084	-4.86	-36.46		25516
				-0.136	-0.126	0.004		-0.196	-1.92	-18.05		25354
	1.000	9	1554	-10432.0	-446.50	280.76	-37301	-1393	-4.59	-34.86		25511
				-0.137	-0.098	0.004		-0.185	-2.24	-20.03		25348
50005	0.000	9	1554	-10432.0	-446.49	280.75	-37301	-1393	-4.59	-34.86		25511
				-0.137	-0.098	0.004		-0.185	-2.24	-20.03		25348
	1.000	9	1554	-10506.2	-321.27	261.65	-40294	-1949	-4.32	-33.23		25505
				-0.138	-0.071	0.003		-0.174	-2.57	-22.04		25342
50006	0.000	9	1554	-10506.2	-321.26	261.64	-40294	-1949	-4.32	-33.23		25505
				-0.138	-0.071	0.003		-0.174	-2.57	-22.04		25342
	1.000	9	1554	-10580.4	-194.79	242.47	-43774	-3237	-4.04	-31.58		25499
				-0.139	-0.043	0.003		-0.163	-2.89	-24.08		25335
50007	0.000	9	1554	-10580.4	-194.79	242.47	-43774	-3237	-4.04	-31.58		25499
				-0.139	-0.043	0.003		-0.163	-2.89	-24.08		25335
	1.000	9	1554	-10654.6	-67.43	223.24	-47868	-9413	-3.77	-29.92		25493
				-0.140	-0.015	0.003		-0.151	-3.22	-26.13		25329
50008	0.000	9	1554	-10654.5	-67.43	223.24	-47868	-9414	-3.77	-29.92		25493
				-0.140	-0.015	0.003		-0.151	-3.22	-26.13		25329
	1.000	9	1554	-10728.7	60.36	203.95	-52753	10589	-3.77	-29.94		25486
				-0.141	0.013	0.003		-0.151	-3.27	-26.51		25322
50009	0.000	9	1554	-10728.7	60.36	203.95	-52753	10588	-3.77	-29.94		25486
				-0.141	0.013	0.003		-0.151	-3.27	-26.51		25322
	1.000	9	1554	-10802.9	188.11	184.61	-58679	3421	-4.07	-31.84		25479
				-0.142	0.042	0.002		-0.164	-3.01	-25.01		25315
50010	0.000	9	1554	-10802.9	188.11	184.61	-58679	3421	-4.07	-31.84		25479
				-0.142	0.042	0.002		-0.164	-3.01	-25.01		25315
	1.000	9	1554	-10877.1	315.38	165.23	-66015	2054	-4.38	-33.73		25472
				-0.143	0.070	0.002		-0.176	-2.75	-23.53		25308
50011	0.000	9	1554	-10877.1	315.39	165.23	-66015	2054	-4.38	-33.73		25472
				-0.143	0.070	0.002		-0.176	-2.75	-23.53		25308
	1.000	9	1554	-10951.3	441.67	145.81	-75326	1477	-4.68	-35.61		25464
				-0.144	0.098	0.002		-0.189	-2.50	-22.06		25301
50012	0.000	9	1554	-10951.3	441.68	145.80	-75327	1477	-4.68	-35.61		25464
				-0.144	0.098	0.002		-0.189	-2.50	-22.06		25301
	1.000	9	1554	-11025.5	566.60	126.35	-87531	1159	-4.98	-37.48		25456
				-0.145	0.125	0.002		-0.201	-2.24	-20.61		25293
50013	0.000	9	1554	-11025.6	566.60	126.35	-87529	1159	-4.98	-37.48		25456
				-0.145	0.125	0.002		-0.201	-2.24	-20.61		25293
	1.000	9	1554	-11099.8	689.59	106.87	-	959.3	-5.27	-39.32		25448
				-0.146	0.152	0.001		-0.213	-1.99	-19.19		25286

Røydalen\_NORD\_GSR

**Nonlinear Stresses**

Beam	x[m]	SNo	LC	Ni	Myi	Mzi	yn	zn	σ-min	σ-s	σ-t	Ey-eff
				[kN]	[kNm]	[kNm]	[mm]	[mm]	[MPa]	[MPa]	[MPa]	[N/mm <sup>2</sup> ]
				ε-θ	ky	kz	fact	ε	σ-max	σ-s	σ-t	Ez-eff
				[o/oo]	[1/km]	[1/km]	[-]	[o/oo]	[MPa]	[MPa]	[MPa]	[N/mm <sup>2</sup> ]
50014	0.000	9	1554	-11099.8	689.59	106.87	-.-	959.3	-5.27	-39.32		25448
				-0.146	0.152	0.001		-0.213	-1.99	-19.19		25286
	1.000	9	1554	-11174.0	810.26	87.37	-.-	822.1	-5.56	-41.14		25439
				-0.147	0.179	0.001		-0.225	-1.74	-17.80		25278
50015	0.000	9	1554	-11174.0	810.26	87.37	-.-	822.1	-5.56	-41.14		25439
				-0.147	0.179	0.001		-0.225	-1.74	-17.80		25278
	1.000	9	1554	-11248.2	928.05	67.85	-.-	722.8	-5.84	-42.91		25431
				-0.148	0.205	0.001		-0.237	-1.50	-16.46		25270
50016	0.000	9	1554	-11248.2	928.05	67.85	-.-	722.8	-5.84	-42.91		25431
				-0.148	0.205	0.001		-0.237	-1.50	-16.46		25270
	1.000	9	1554	-11322.4	1042.50	48.32	-.-	648.0	-6.11	-44.64		25422
				-0.150	0.231	0.001		-0.249	-1.27	-15.16		25261
50017	0.000	9	1554	-11322.5	1042.51	48.33	-.-	648.0	-6.11	-44.65		25422
				-0.150	0.231	0.001		-0.249	-1.27	-15.16		25261
	1.000	9	1554	-11396.7	1153.14	28.79	-.-	589.9	-6.37	-46.33		25413
				-0.151	0.255	0.000		-0.260	-1.05	-13.91		25253
50018	0.000	9	1554	-9567.2	-1434.83	361.91	-25923	-398.1	-6.59	-46.80		23434
				-0.126	-0.317	0.005		-0.269	0.00	-3.67		24681
	1.000	9	1554	-9648.8	-1346.68	351.93	-27617	-429.3	-6.40	-45.66		25226
				-0.127	-0.297	0.005		-0.261	0.00	-5.27		25224
50019	0.000	9	1554	-9648.7	-1346.67	351.94	-27616	-429.3	-6.40	-45.66		25226
				-0.127	-0.297	0.005		-0.261	0.00	-5.27		25224
	1.000	9	1554	-9713.7	-1254.29	341.88	-28677	-464.1	-6.21	-44.46		25613
				-0.128	-0.276	0.004		-0.253	-0.09	-6.76		25431
50020	0.000	9	1554	-9713.6	-1254.29	341.88	-28677	-464.1	-6.21	-44.46		25613
				-0.128	-0.276	0.004		-0.253	-0.09	-6.76		25431
	1.000	9	1554	-9795.1	-1157.88	331.75	-29768	-506.7	-6.02	-43.31		25558
				-0.129	-0.255	0.004		-0.245	-0.35	-8.35		25398
50021	0.000	9	1554	-9795.1	-1157.88	331.75	-29768	-506.7	-6.02	-43.31		25558
				-0.129	-0.255	0.004		-0.245	-0.35	-8.35		25398
	1.000	9	1554	-9864.2	-1057.86	321.55	-30906	-558.1	-5.81	-42.05		25553
				-0.130	-0.233	0.004		-0.236	-0.61	-9.94		25393
50022	0.000	9	1554	-9864.1	-1057.86	321.54	-30906	-558.1	-5.81	-42.05		25553
				-0.130	-0.233	0.004		-0.236	-0.61	-9.94		25393
	1.000	9	1554	-9938.3	-954.30	311.27	-32143	-622.8	-5.59	-40.75		25549
				-0.131	-0.210	0.004		-0.227	-0.88	-11.60		25388
50023	0.000	9	1554	-9938.3	-954.30	311.27	-32143	-622.8	-5.59	-40.75		25549
				-0.131	-0.210	0.004		-0.227	-0.88	-11.60		25388
	1.000	9	1554	-10012.5	-847.66	300.92	-33474	-705.9	-5.37	-39.42		25544
				-0.132	-0.187	0.004		-0.218	-1.16	-13.31		25382
50024	0.000	9	1554	-10012.4	-847.66	300.92	-33474	-705.9	-5.37	-39.42		25544
				-0.132	-0.187	0.004		-0.218	-1.16	-13.31		25382
	1.000	9	1554	-10086.6	-738.08	290.50	-34910	-816.2	-5.14	-38.04		25539
				-0.133	-0.163	0.004		-0.208	-1.45	-15.05		25377
50025	0.000	9	1554	-10086.6	-738.08	290.50	-34910	-816.2	-5.14	-38.04		25539
				-0.133	-0.163	0.004		-0.208	-1.45	-15.05		25377
	1.000	9	1554	-10160.8	-625.99	280.01	-36464	-968.9	-4.91	-36.63		25534
				-0.134	-0.138	0.004		-0.198	-1.74	-16.84		25371
50026	0.000	9	1554	-10160.7	-625.99	280.01	-36464	-968.9	-4.91	-36.63		25534
				-0.134	-0.138	0.004		-0.198	-1.74	-16.84		25371
	1.000	9	1554	-10234.9	-511.63	269.46	-38151	-1194	-4.67	-35.18		25528
				-0.135	-0.113	0.004		-0.188	-2.03	-18.66		25365

Røydalen\_NORD\_GSR

**Nonlinear Stresses**

Beam	x[m]	SNo	LC	Ni [kN]	Myi [kNm]	Mzi [kNm]	yn [mm]	zn [mm]	σ-min [MPa]	σ-s [MPa]	σ-t [MPa]	Ey-eff [N/mm2]
				ε-θ [o/oo]	ky [1/km]	kz [1/km]	fact [-]	ε [o/oo]	σ-max [MPa]	σ-s [MPa]	σ-t [MPa]	Ez-eff [N/mm2]
50027	0.000	9	1554	-10234.9	-511.63	269.46	-38150	-1194	-4.67	-35.18		25528
				-0.135	-0.113	0.004		-0.188	-2.03	-18.66		25365
	1.000	9	1554	-10309.1	-395.35	258.84	-39986	-1555	-4.42	-33.71		25522
				-0.136	-0.087	0.003		-0.178	-2.33	-20.51		25359
50028	0.000	9	1554	-10309.1	-395.35	258.84	-39987	-1555	-4.42	-33.71		25522
				-0.136	-0.087	0.003		-0.178	-2.33	-20.51		25359
	1.000	9	1554	-10383.2	-277.60	248.16	-41992	-2230	-4.17	-32.23		25517
				-0.137	-0.061	0.003		-0.168	-2.63	-22.38		25353
50029	0.000	9	1554	-10383.2	-277.60	248.16	-41992	-2230	-4.17	-32.23		25517
				-0.137	-0.061	0.003		-0.168	-2.63	-22.38		25353
	1.000	9	1554	-10457.4	-158.74	237.43	-44193	-3926	-3.92	-30.72		25510
				-0.137	-0.035	0.003		-0.158	-2.94	-24.27		25347
50030	0.000	9	1554	-10457.4	-158.74	237.43	-44193	-3926	-3.92	-30.72		25510
				-0.137	-0.035	0.003		-0.158	-2.94	-24.27		25347
	1.000	9	1554	-10531.6	-39.07	226.63	-46617	-16063	-3.67	-29.21		25504
				-0.138	-0.009	0.003		-0.147	-3.24	-26.18		25340
50031	0.000	9	1554	-10531.6	-39.07	226.63	-46617	-16064	-3.67	-29.21		25504
				-0.138	-0.009	0.003		-0.147	-3.24	-26.18		25340
	1.000	9	1554	-10605.8	81.02	215.79	-49298	7799	-3.78	-29.95		25497
				-0.139	0.018	0.003		-0.152	-3.18	-25.84		25333
50032	0.000	9	1554	-10605.8	81.02	215.79	-49299	7799	-3.78	-29.95		25497
				-0.139	0.018	0.003		-0.152	-3.18	-25.84		25333
	1.000	9	1554	-10680.0	200.97	204.89	-52281	3166	-4.07	-31.77		25490
				-0.140	0.044	0.003		-0.164	-2.93	-24.42		25326
50033	0.000	9	1554	-10680.0	200.97	204.89	-52281	3166	-4.07	-31.77		25490
				-0.140	0.044	0.003		-0.164	-2.93	-24.42		25326
	1.000	9	1554	-10754.2	320.53	193.95	-55616	1999	-4.36	-33.59		25483
				-0.141	0.071	0.003		-0.176	-2.69	-23.00		25319
50034	0.000	9	1554	-10754.2	320.53	193.95	-55616	1999	-4.36	-33.59		25483
				-0.141	0.071	0.003		-0.176	-2.69	-23.00		25319
	1.000	9	1554	-10828.4	439.29	182.96	-59369	1469	-4.65	-35.41		25475
				-0.143	0.097	0.002		-0.188	-2.44	-21.60		25312
50035	0.000	9	1554	-10828.4	439.29	182.96	-59369	1469	-4.65	-35.41		25475
				-0.143	0.097	0.002		-0.188	-2.44	-21.60		25312
	1.000	9	1554	-10902.6	556.66	171.93	-63622	1167	-4.94	-37.20		25467
				-0.144	0.123	0.002		-0.200	-2.20	-20.22		25305
50036	0.000	9	1554	-10902.6	556.66	171.93	-63622	1167	-4.94	-37.20		25467
				-0.144	0.123	0.002		-0.200	-2.20	-20.22		25305
	1.000	9	1554	-10976.8	672.39	160.86	-68478	973.1	-5.22	-38.98		25459
				-0.145	0.149	0.002		-0.211	-1.96	-18.87		25297
50037	0.000	9	1554	-10976.8	672.39	160.86	-68478	973.1	-5.22	-38.98		25459
				-0.145	0.149	0.002		-0.211	-1.96	-18.87		25297
	1.000	9	1554	-11051.0	785.94	149.75	-74075	838.4	-5.49	-40.73		25451
				-0.146	0.174	0.002		-0.223	-1.73	-17.54		25289
50038	0.000	9	1554	-11051.0	785.95	149.75	-74075	838.4	-5.49	-40.73		25451
				-0.146	0.174	0.002		-0.223	-1.73	-17.54		25289
	1.000	9	1554	-11125.2	896.89	138.61	-80591	739.8	-5.76	-42.44		25442
				-0.147	0.198	0.002		-0.234	-1.50	-16.26		25281
50039	0.000	9	1554	-11125.3	896.89	138.61	-80590	739.8	-5.76	-42.44		25442
				-0.147	0.198	0.002		-0.234	-1.50	-16.26		25281
	1.000	9	1554	-11199.5	1004.79	127.44	-88270	665.0	-6.03	-44.12		25434
				-0.148	0.222	0.002		-0.245	-1.28	-15.01		25273

Røydalen\_NORD\_GSR

**Nonlinear Stresses**

Beam	x[m]	SNo	LC	Ni [kN] ε-θ	Myi [kNm] ky	Mzi [kNm] kz	yn [mm] fact	zn [mm] ε	σ-min [MPa]	σ-s [MPa]	σ-t [MPa]	Ey-eff [N/mm2]
				[o/oo]	[1/km]	[1/km]	[-]	[o/oo]	σ-max [MPa]	σ-s [MPa]	σ-t [MPa]	Ez-eff [N/mm2]
50040	0.000	9	1554	-11199.5	1004.79	127.44	-88271	665.0	-6.03	-44.12		25434
				-0.148	0.222	0.002		-0.245	-1.28	-15.01		25273
	1.000	9	1554	-11273.7	1109.27	116.24	-97454	606.6	-6.28	-45.75		25425
				-0.149	0.245	0.002		-0.256	-1.06	-13.82		25265
50041	0.000	9	1554	-11273.7	1109.28	116.24	-97455	606.6	-6.28	-45.75		25425
				-0.149	0.245	0.002		-0.256	-1.06	-13.82		25265
	1.000	9	1554	-11347.9	1209.89	105.02	..	560.1	-6.52	-47.32		25416
				-0.150	0.268	0.001		-0.266	-0.86	-12.67		25257
50042	0.000	9	1554	-11348.0	1209.89	105.02	..	560.1	-6.52	-47.32		25416
				-0.150	0.268	0.001		-0.266	-0.86	-12.67		25257
	1.000	9	1554	-11425.0	1306.11	93.78	..	522.6	-6.76	-48.85		25407
				-0.151	0.289	0.001		-0.276	-0.66	-11.60		25248
50043	0.000	9	1554	-11425.1	1306.11	93.78	..	522.6	-6.76	-48.85		25407
				-0.151	0.289	0.001		-0.276	-0.66	-11.60		25248
	1.000	9	1554	-11493.7	1397.64	82.53	..	491.5	-6.98	-50.29		25398
				-0.152	0.310	0.001		-0.286	-0.48	-10.57		25240
50044	0.000	9	1554	-9876.0	-1802.09	349.20	-24010	-303.7	-7.66	-53.68		17527
				-0.127	-0.420	0.005		-0.315	0.00	2.69		21850
	1.000	9	1554	-9950.2	-1692.66	343.19	-26172	-339.2	-7.36	-51.85		19383
				-0.130	-0.384	0.005		-0.301	0.00	-0.23		22915
50045	0.000	9	1554	-9950.1	-1692.65	343.19	-26172	-339.2	-7.36	-51.85		19382
				-0.130	-0.384	0.005		-0.301	0.00	-0.23		22914
	1.000	9	1554	-10024.4	-1577.88	337.09	-28341	-376.2	-7.07	-50.09		21753
				-0.132	-0.351	0.005		-0.289	0.00	-2.77		24008
50046	0.000	9	1554	-10024.3	-1577.88	337.09	-28340	-376.2	-7.07	-50.09		21753
				-0.132	-0.351	0.005		-0.289	0.00	-2.77		24008
	1.000	9	1554	-10103.0	-1457.98	330.92	-30468	-414.7	-6.79	-48.41		24562
				-0.133	-0.322	0.004		-0.278	0.00	-4.98		25003
50047	0.000	9	1554	-10103.0	-1457.98	330.91	-30468	-414.7	-6.79	-48.41		24562
				-0.133	-0.322	0.004		-0.278	0.00	-4.98		25003
	1.000	9	1554	-10171.8	-1333.37	324.66	-31618	-456.6	-6.53	-46.79		25565
				-0.134	-0.294	0.004		-0.266	-0.06	-6.94		25385
50048	0.000	9	1554	-10171.7	-1333.37	324.66	-31618	-456.6	-6.53	-46.79		25565
				-0.134	-0.294	0.004		-0.266	-0.06	-6.94		25385
	1.000	9	1554	-10253.2	-1204.47	318.33	-32451	-509.5	-6.26	-45.16		25515
				-0.135	-0.266	0.004		-0.255	-0.39	-8.96		25356
50049	0.000	9	1554	-10253.2	-1204.47	318.33	-32451	-509.5	-6.26	-45.16		25515
				-0.135	-0.266	0.004		-0.255	-0.39	-8.96		25356
	1.000	9	1554	-10322.5	-1071.53	311.93	-33310	-576.0	-5.98	-43.45		25512
				-0.136	-0.236	0.004		-0.243	-0.73	-11.00		25352
50050	0.000	9	1554	-10322.5	-1071.53	311.93	-33309	-576.0	-5.98	-43.45		25512
				-0.136	-0.236	0.004		-0.243	-0.73	-11.00		25352
	1.000	9	1554	-10396.7	-935.00	305.45	-34230	-664.3	-5.70	-41.71		25508
				-0.137	-0.206	0.004		-0.231	-1.08	-13.10		25347
50051	0.000	9	1554	-10396.6	-935.00	305.45	-34230	-664.3	-5.70	-41.71		25508
				-0.137	-0.206	0.004		-0.231	-1.08	-13.10		25347
	1.000	9	1554	-10470.8	-795.23	298.90	-35203	-786.0	-5.40	-39.92		25503
				-0.138	-0.175	0.004		-0.219	-1.43	-15.24		25342
50052	0.000	9	1554	-10470.8	-795.23	298.90	-35203	-786.0	-5.40	-39.92		25503
				-0.138	-0.175	0.004		-0.219	-1.43	-15.24		25342
	1.000	9	1554	-10544.9	-652.62	292.28	-36231	-963.9	-5.10	-38.09		25499
				-0.139	-0.144	0.004		-0.206	-1.79	-17.43		25336

Røydalen\_NORD\_GSR

**Nonlinear Stresses**

Beam	x[m]	SNo	LC	Ni [kN] ε-θ	Myi [kNm] ky	Mzi [kNm] kz	yn [mm] fact	zn [mm] ε	σ-min [MPa] σ-max	σ-s [MPa] σ-s	σ-t [MPa] σ-t	Ey-eff [N/mm2]	Ez-eff [N/mm2]
50053	0.000	9	1554	-10544.9	-652.62	292.28	-36230	-963.9	-5.10	-38.09		25499	
				-0.139	-0.144	0.004		-0.206	-1.79	-17.43		25336	
	1.000	9	1554	-10619.1	-507.65	285.59	-37319	-1247	-4.79	-36.24		25494	
				-0.140	-0.112	0.004		-0.194	-2.16	-19.66		25331	
50054	0.000	9	1554	-10619.1	-507.65	285.59	-37318	-1247	-4.79	-36.24		25493	
				-0.140	-0.112	0.004		-0.194	-2.16	-19.66		25331	
	1.000	9	1554	-10693.2	-360.71	278.84	-38472	-1767	-4.48	-34.35		25488	
				-0.141	-0.080	0.004		-0.181	-2.53	-21.92		25325	
50055	0.000	9	1554	-10693.2	-360.71	278.84	-38472	-1767	-4.48	-34.35		25488	
				-0.141	-0.080	0.004		-0.181	-2.53	-21.92		25325	
	1.000	9	1554	-10767.4	-212.25	272.02	-39696	-3022	-4.16	-32.45		25482	
				-0.142	-0.047	0.004		-0.167	-2.90	-24.21		25319	
50056	0.000	9	1554	-10767.4	-212.25	272.02	-39696	-3022	-4.16	-32.45		25482	
				-0.142	-0.047	0.004		-0.167	-2.90	-24.21		25319	
	1.000	9	1554	-10841.6	-62.85	265.13	-40998	-10274	-3.84	-30.54		25476	
				-0.143	-0.014	0.003		-0.154	-3.27	-26.51		25312	
50057	0.000	9	1554	-10841.6	-62.85	265.13	-40998	-10274	-3.84	-30.54		25476	
				-0.143	-0.014	0.003		-0.154	-3.27	-26.51		25312	
	1.000	9	1554	-10915.8	87.04	258.18	-42385	7468	-3.92	-31.05		25469	
				-0.144	0.019	0.003		-0.157	-3.24	-26.40		25305	
50058	0.000	9	1554	-10915.8	87.04	258.18	-42385	7468	-3.92	-31.05		25469	
				-0.144	0.019	0.003		-0.157	-3.24	-26.40		25305	
	1.000	9	1554	-10990.0	236.95	251.17	-43863	2762	-4.28	-33.31		25462	
				-0.145	0.052	0.003		-0.172	-2.93	-24.55		25298	
50059	0.000	9	1554	-10990.0	236.95	251.17	-43863	2762	-4.28	-33.31		25462	
				-0.145	0.052	0.003		-0.172	-2.93	-24.55		25298	
	1.000	9	1554	-11064.2	386.33	244.10	-45442	1706	-4.64	-35.57		25454	
				-0.146	0.085	0.003		-0.187	-2.61	-22.70		25291	
50060	0.000	9	1554	-11064.2	386.34	244.10	-45442	1706	-4.64	-35.57		25454	
				-0.146	0.085	0.003		-0.187	-2.61	-22.70		25291	
	1.000	9	1554	-11138.4	534.72	236.98	-47131	1241	-5.00	-37.81		25446	
				-0.147	0.118	0.003		-0.202	-2.29	-20.87		25283	
50061	0.000	9	1554	-11138.4	534.72	236.98	-47132	1241	-5.00	-37.81		25446	
				-0.147	0.118	0.003		-0.202	-2.29	-20.87		25283	
	1.000	9	1554	-11212.6	681.44	229.80	-48942	980.4	-5.35	-40.04		25438	
				-0.148	0.151	0.003		-0.217	-1.98	-19.07		25275	
50062	0.000	9	1554	-11212.6	681.45	229.80	-48942	980.4	-5.35	-40.04		25438	
				-0.148	0.151	0.003		-0.217	-1.98	-19.07		25275	
	1.000	9	1554	-11286.8	826.19	222.57	-50885	814.3	-5.70	-42.25		25429	
				-0.149	0.183	0.003		-0.231	-1.67	-17.30		25267	
50063	0.000	9	1554	-11286.9	826.19	222.57	-50886	814.3	-5.70	-42.25		25429	
				-0.149	0.183	0.003		-0.231	-1.67	-17.30		25267	
	1.000	9	1554	-11361.1	968.19	215.29	-52977	699.8	-6.04	-44.42		25420	
				-0.150	0.214	0.003		-0.246	-1.37	-15.56		25259	
50064	0.000	9	1554	-11361.1	968.19	215.28	-52978	699.8	-6.04	-44.42		25420	
				-0.150	0.214	0.003		-0.246	-1.37	-15.56		25259	
	1.000	9	1554	-11435.3	1107.04	207.96	-55233	616.3	-6.37	-46.55		25410	
				-0.151	0.245	0.003		-0.260	-1.07	-13.88		25250	
50065	0.000	9	1554	-11435.4	1107.04	207.96	-55233	616.3	-6.37	-46.55		25410	
				-0.151	0.245	0.003		-0.260	-1.07	-13.88		25250	
	1.000	9	1554	-11509.5	1242.12	200.59	-57669	553.2	-6.70	-48.64		25400	
				-0.152	0.275	0.003		-0.273	-0.78	-12.24		25241	

Røydalen\_NORD\_GSR

**Nonlinear Stresses**

Beam	x[m]	SNo	LC	Ni [kN] ε-θ	Myi [kNm] ky	Mzi [kNm] kz	yn [mm] fact	zn [mm] ε	σ-min [MPa]	σ-s [MPa]	σ-t [MPa]	Ey-eff [N/mm2]
				[o/oo]	[1/km]	[1/km]	[-]	[o/oo]	σ-max [MPa]	σ-s [MPa]	σ-t [MPa]	Ez-eff [N/mm2]
50066	0.000	9	1554	-11509.6	1242.12	200.59	-57669	553.2	-6.70	-48.64		25400
				-0.152	0.275	0.003		-0.273	-0.78	-12.24		25241
	1.000	9	1554	-11589.8	1372.93	193.17	-60339	504.3	-7.01	-50.68		25390
				-0.153	0.304	0.003		-0.287	-0.51	-10.68		25232
50067	0.000	9	1554	-11589.9	1372.93	193.17	-60340	504.3	-7.01	-50.68		25390
				-0.153	0.304	0.003		-0.287	-0.51	-10.69		25232
	1.000	9	1554	-11654.9	1498.95	185.71	-63173	464.7	-7.31	-52.61		25404
				-0.154	0.332	0.002		-0.300	-0.23	-9.15		25236
50068	0.000	9	1554	-11655.0	1498.94	185.71	-63174	464.7	-7.31	-52.61		25404
				-0.154	0.332	0.002		-0.300	-0.23	-9.15		25236
	1.000	9	1554	-11728.9	1619.66	178.22	-66292	433.2	-7.60	-54.50		25378
				-0.156	0.359	0.002		-0.312	0.00	-7.72		25215
50069	0.000	9	1554	-11728.9	1619.65	178.22	-66291	433.2	-7.60	-54.50		25378
				-0.156	0.359	0.002		-0.312	0.00	-7.72		25215
	1.000	9	1554	-11806.0	1734.52	170.69	-68314	406.7	-7.88	-56.35		23853
				-0.157	0.385	0.002		-0.324	0.00	-6.31		24716
50070	0.000	9	1554	-11806.1	1734.52	170.68	-68316	406.7	-7.88	-56.35		23853
				-0.157	0.385	0.002		-0.324	0.00	-6.31		24716
	1.000	9	1554	-11878.4	1842.96	163.12	-69781	382.4	-8.16	-58.18		21960
				-0.157	0.412	0.002		-0.336	0.00	-4.81		24003
50071	0.000	9	1554	-9569.2	-2181.00	318.80	-18240	-178.2	-8.97	-61.04		13683
				-0.107	-0.599	0.006		-0.371	0.00	18.32		18081
	1.000	9	1554	-9642.3	-2045.06	312.53	-21611	-220.8	-8.43	-57.98		14585
				-0.116	-0.525	0.005		-0.348	0.00	11.64		19365
50072	0.000	9	1554	-9642.2	-2045.10	312.54	-21609	-220.8	-8.43	-57.98		14585
				-0.116	-0.525	0.005		-0.348	0.00	11.64		19365
	1.000	9	1554	-9717.4	-1902.00	306.16	-24958	-266.2	-7.93	-55.07		15975
				-0.122	-0.460	0.005		-0.326	0.00	6.10		20730
50073	0.000	9	1554	-9717.4	-1902.02	306.17	-24956	-266.2	-7.93	-55.07		15975
				-0.122	-0.460	0.005		-0.326	0.00	6.10		20730
	1.000	9	1554	-9791.5	-1752.66	299.71	-28254	-313.8	-7.47	-52.34		18012
				-0.127	-0.405	0.004		-0.306	0.00	1.57		22160
50074	0.000	9	1554	-9791.4	-1752.66	299.71	-28253	-313.8	-7.47	-52.34		18012
				-0.127	-0.405	0.004		-0.306	0.00	1.57		22160
	1.000	9	1554	-9865.7	-1597.48	293.18	-31501	-363.2	-7.05	-49.81		20867
				-0.130	-0.357	0.004		-0.288	0.00	-2.09		23637
50075	0.000	9	1554	-9865.6	-1597.48	293.18	-31500	-363.2	-7.05	-49.81		20867
				-0.130	-0.357	0.004		-0.288	0.00	-2.09		23637
	1.000	9	1554	-9944.1	-1437.16	286.57	-34633	-414.3	-6.67	-47.49		24587
				-0.131	-0.317	0.004		-0.272	0.00	-5.05		25037
50076	0.000	9	1554	-9944.0	-1437.17	286.58	-34632	-414.3	-6.67	-47.49		24587
				-0.131	-0.317	0.004		-0.272	0.00	-5.05		25037
	1.000	9	1554	-10013.3	-1272.12	279.90	-36085	-471.5	-6.31	-45.26		25576
				-0.132	-0.280	0.004		-0.257	-0.18	-7.57		25399
50077	0.000	9	1554	-10013.3	-1272.12	279.90	-36085	-471.5	-6.31	-45.26		25576
				-0.132	-0.280	0.004		-0.257	-0.18	-7.57		25399
	1.000	9	1554	-10090.1	-1102.88	273.16	-37206	-547.4	-5.96	-43.09		25532
				-0.133	-0.243	0.004		-0.242	-0.60	-10.12		25372
50078	0.000	9	1554	-10090.1	-1102.87	273.16	-37206	-547.4	-5.96	-43.09		25532
				-0.133	-0.243	0.004		-0.242	-0.60	-10.12		25372
	1.000	9	1554	-10163.8	-929.81	266.35	-38394	-653.3	-5.59	-40.83		25529
				-0.134	-0.205	0.003		-0.227	-1.04	-12.72		25368



Røydalen\_NORD\_GSR

**Nonlinear Stresses**

Beam	x[m]	SNo	LC	Ni [kN] ε-θ	Myi [kNm] ky	Mzi [kNm] kz	yn [mm] fact	zn [mm] ε	σ-min [MPa] σ-max	σ-s [MPa] σ-s	σ-t [MPa] σ-t	Ey-eff [N/mm2]	Ez-eff [N/mm2]
50079	0.000	9	1554	-10163.7	-929.80	266.35	-38393	-653.3	-5.59	-40.83		25529	
				-0.134	-0.205	0.003		-0.227	-1.04	-12.72		25368	
	1.000	9	1554	-10237.9	-753.46	259.48	-39661	-811.3	-5.21	-38.53		25525	
				-0.135	-0.166	0.003		-0.211	-1.48	-15.37		25363	
50080	0.000	9	1554	-10237.9	-753.46	259.48	-39660	-811.3	-5.21	-38.53		25525	
				-0.135	-0.166	0.003		-0.211	-1.48	-15.37		25363	
	1.000	9	1554	-10312.0	-574.42	252.55	-41013	-1071	-4.83	-36.20		25521	
				-0.136	-0.127	0.003		-0.195	-1.92	-18.07		25358	
50081	0.000	9	1554	-10312.0	-574.42	252.55	-41012	-1071	-4.83	-36.20		25521	
				-0.136	-0.127	0.003		-0.195	-1.92	-18.07		25358	
	1.000	9	1554	-10386.2	-393.11	245.56	-42457	-1575	-4.44	-33.83		25515	
				-0.137	-0.087	0.003		-0.179	-2.37	-20.80		25352	
50082	0.000	9	1554	-10386.2	-393.10	245.56	-42457	-1575	-4.44	-33.83		25515	
				-0.137	-0.087	0.003		-0.179	-2.37	-20.80		25352	
	1.000	9	1554	-10460.4	-210.20	238.52	-44005	-2966	-4.04	-31.45		25510	
				-0.138	-0.046	0.003		-0.162	-2.82	-23.56		25346	
50083	0.000	9	1554	-10460.3	-210.19	238.51	-44006	-2966	-4.04	-31.45		25510	
				-0.138	-0.046	0.003		-0.162	-2.82	-23.56		25346	
	1.000	9	1554	-10534.5	-26.15	231.41	-45666	-24003	-3.64	-29.06		25504	
				-0.139	-0.006	0.003		-0.146	-3.27	-26.34		25340	
50084	0.000	9	1554	-10534.5	-26.16	231.42	-45665	-24000	-3.64	-29.06		25504	
				-0.139	-0.006	0.003		-0.146	-3.27	-26.34		25340	
	1.000	9	1554	-10608.7	158.31	224.27	-47450	3993	-3.96	-31.07		25497	
				-0.140	0.035	0.003		-0.159	-3.00	-24.74		25333	
50085	0.000	9	1554	-10608.7	158.31	224.26	-47451	3993	-3.96	-31.07		25497	
				-0.140	0.035	0.003		-0.159	-3.00	-24.74		25333	
	1.000	9	1554	-10682.9	342.63	217.06	-49372	1858	-4.40	-33.81		25489	
				-0.141	0.076	0.003		-0.177	-2.60	-22.41		25326	
50086	0.000	9	1554	-10682.9	342.63	217.07	-49372	1858	-4.40	-33.81		25489	
				-0.141	0.076	0.003		-0.177	-2.60	-22.41		25326	
	1.000	9	1554	-10757.1	526.23	209.82	-51445	1218	-4.84	-36.54		25481	
				-0.142	0.116	0.003		-0.196	-2.20	-20.10		25318	
50087	0.000	9	1554	-10757.1	526.23	209.82	-51446	1218	-4.84	-36.54		25481	
				-0.142	0.116	0.003		-0.196	-2.20	-20.10		25318	
	1.000	9	1554	-10831.3	708.44	202.53	-53687	911.7	-5.27	-39.27		25472	
				-0.143	0.157	0.003		-0.214	-1.81	-17.81		25310	
50088	0.000	9	1554	-10831.4	708.44	202.53	-53689	911.7	-5.27	-39.27		25472	
				-0.143	0.157	0.003		-0.214	-1.81	-17.81		25310	
	1.000	9	1554	-10905.6	888.57	195.20	-56119	732.3	-5.70	-41.97		25463	
				-0.144	0.196	0.003		-0.231	-1.42	-15.55		25301	
50089	0.000	9	1554	-10905.6	888.58	195.20	-56119	732.3	-5.70	-41.97		25463	
				-0.144	0.196	0.003		-0.231	-1.42	-15.55		25301	
	1.000	9	1554	-10979.8	1066.11	187.83	-58758	615.0	-6.12	-44.64		25452	
				-0.145	0.236	0.002		-0.249	-1.03	-13.33		25292	
50090	0.000	9	1554	-10979.9	1066.11	187.83	-58759	615.0	-6.12	-44.64		25453	
				-0.145	0.236	0.002		-0.249	-1.03	-13.33		25292	
	1.000	9	1554	-11055.7	1240.27	180.43	-61643	532.7	-6.54	-47.28		25442	
				-0.146	0.274	0.002		-0.267	-0.65	-11.16		25283	
50091	0.000	9	1554	-11055.8	1240.27	180.43	-61645	532.7	-6.54	-47.28		25442	
				-0.146	0.274	0.002		-0.267	-0.65	-11.16		25283	
	1.000	9	1554	-11125.6	1410.41	172.99	-64768	471.8	-6.93	-49.83		25455	
				-0.147	0.312	0.002		-0.283	-0.28	-9.04		25286	

Røydalen\_NORD\_GSR

**Nonlinear Stresses**

Beam	x[m]	SNo	LC	Ni [kN] ε-θ [o/oo]	Myi [kNm] ky [1/km]	Mzi [kNm] kz [1/km]	yn [mm] fact [-]	zn [mm] ε [o/oo]	σ-min [MPa] σ-max [MPa]	σ-s [MPa] σ-s [MPa]	σ-t [MPa] σ-t [MPa]	Ey-eff [N/mm2] Ez-eff [N/mm2]
50092	0.000	9	1554	-11125.7	1410.41	172.99	-64769	471.8	-6.93	-49.83		25455
				-0.147	0.312	0.002		-0.283	-0.28	-9.04		25286
	1.000	9	1554	-11209.7	1576.01	165.53	-68157	425.9	-7.33	-52.37		25254
				-0.148	0.349	0.002		-0.300	0.00	-7.02		25182
50093	0.000	9	1554	-11209.8	1576.00	165.52	-68161	425.9	-7.33	-52.37		25255
				-0.148	0.349	0.002		-0.300	0.00	-7.02		25182
	1.000	9	1554	-11274.8	1736.23	158.04	-68754	386.1	-7.72	-54.93		22292
				-0.149	0.387	0.002		-0.317	0.00	-4.79		24169
50094	0.000	9	1554	-11274.9	1736.23	158.04	-68753	386.1	-7.72	-54.93		22293
				-0.149	0.387	0.002		-0.317	0.00	-4.79		24169
	1.000	9	1554	-11348.9	1890.51	150.53	-68984	349.2	-8.13	-57.57		19798
				-0.149	0.428	0.002		-0.335	0.00	-2.21		23074
50095	0.000	9	1554	-11348.9	1890.51	150.53	-68987	349.2	-8.13	-57.57		19798
				-0.149	0.428	0.002		-0.335	0.00	-2.21		23074
	1.000	9	1554	-11423.1	2038.02	143.00	-69039	314.9	-8.56	-60.26		17865
				-0.149	0.473	0.002		-0.353	0.00	0.72		22027
50096	0.000	9	1554	-11423.2	2038.02	143.00	-69041	314.9	-8.56	-60.26		17865
				-0.149	0.473	0.002		-0.353	0.00	0.72		22027
	1.000	9	1554	-11497.3	2178.17	135.45	-69038	283.2	-8.99	-62.97		16419
				-0.147	0.520	0.002		-0.372	0.00	4.01		21066
50097	0.000	9	1554	-11497.4	2178.16	135.44	-69044	283.3	-8.99	-62.98		16419
				-0.147	0.520	0.002		-0.372	0.00	4.00		21066
	1.000	9	1554	-11571.5	2310.02	127.87	-69018	254.5	-9.42	-65.68		15337
				-0.145	0.571	0.002		-0.391	0.00	7.60		20187
50098	0.000	9	1554	-11028.2	-3439.01	20.60	36991	13.4	-14.98	-94.85		12030
				0.021	-1.569	0.001		-0.647	0.00	103.27		12071
	0.978	9	1554	-11103.3	-3207.89	26.85	-58626	-30.9	-13.52	-87.68		12179
				-0.039	-1.264	0.001		-0.577	0.00	72.06		13426
50099	0.000	9	1554	-11102.6	-3207.29	26.85	-58748	-30.9	-13.51	-87.66		12180
				-0.039	-1.264	0.001		-0.577	0.00	72.01		13428
	0.978	9	1554	-11174.5	-2947.61	33.05	..	-86.7	-12.06	-80.09		12431
				-0.086	-0.994	0.001		-0.510	0.00	45.61		15127
50100	0.000	9	1554	-11174.0	-2949.03	33.06	..	-86.4	-12.07	-80.13		12429
				-0.086	-0.995	0.001		-0.510	0.00	45.73		15117
	0.978	9	1554	-11247.9	-2667.07	39.17	..	-152.9	-10.72	-72.76		13056
				-0.118	-0.775	0.001		-0.449	0.00	25.36		17135
50101	0.000	9	1554	-11247.6	-2669.40	39.18	..	-152.4	-10.73	-72.81		13048
				-0.118	-0.776	0.001		-0.449	0.00	25.49		17118
	0.978	9	1554	-11319.0	-2374.30	45.20	..	-226.3	-9.57	-66.13		14504
				-0.138	-0.608	0.001		-0.398	0.00	11.05		19354
50102	0.000	9	1554	-11318.8	-2375.67	45.23	..	-226.0	-9.57	-66.16		14495
				-0.138	-0.609	0.001		-0.398	0.00	11.10		19344
	0.978	9	1554	-11392.6	-2073.17	51.21	..	-304.7	-8.60	-60.37		17368
				-0.148	-0.485	0.001		-0.355	0.00	1.26		21721
50103	0.000	9	1554	-11392.4	-2073.42	51.23	..	-304.6	-8.60	-60.37		17364
				-0.148	-0.485	0.001		-0.355	0.00	1.26		21719
	0.978	9	1554	-11465.2	-1763.71	57.19	..	-386.5	-7.79	-55.40		22306
				-0.152	-0.393	0.001		-0.320	0.00	-5.36		24167
50104	0.000	9	1554	-11465.1	-1763.70	57.20	..	-386.5	-7.79	-55.40		22306
				-0.152	-0.393	0.001		-0.320	0.00	-5.36		24167
	0.978	9	1554	-11537.0	-1447.25	63.13	..	-476.5	-7.10	-51.02		25401
				-0.153	-0.321	0.001		-0.290	-0.38	-10.08		25240

Røydalen\_NORD\_GSR

**Nonlinear Stresses**

Beam	x[m]	SNo	LC	Ni [kN] ε-θ	Myi [kNm] ky	Mzi [kNm] kz	yn [mm] fact	zn [mm] ε	σ-min [MPa]	σ-s [MPa]	σ-t [MPa]	Ey-eff [N/mm2]
				[o/oo]	[1/km]	[1/km]	[-]	[o/oo]	σ-max [MPa]	σ-s [MPa]	σ-t [MPa]	Ez-eff [N/mm2]
50105	0.000	9	1554	-11536.8	-1447.27	63.12	-.-	-476.5	-7.10	-51.02		25401
				-0.153	-0.321	0.001		-0.290	-0.38	-10.08		25240
	0.978	9	1554	-11612.3	-1125.26	69.02	-.-	-615.6	-6.40	-46.70		25394
				-0.153	-0.249	0.001		-0.261	-1.16	-14.69		25234
50106	0.000	9	1554	-11612.2	-1125.28	69.03	-.-	-615.6	-6.40	-46.70		25394
				-0.153	-0.249	0.001		-0.261	-1.16	-14.69		25234
	0.978	9	1554	-11684.7	-798.67	74.90	-.-	-871.3	-5.69	-42.31		25393
				-0.154	-0.177	0.001		-0.231	-1.95	-19.37		25231
50107	0.000	9	1554	-11684.6	-798.68	74.90	-.-	-871.3	-5.69	-42.31		25393
				-0.154	-0.177	0.001		-0.231	-1.95	-19.37		25231
	0.978	9	1554	-11757.2	-468.53	80.74	-.-	-1493	-4.97	-37.89		25390
				-0.155	-0.104	0.001		-0.201	-2.73	-24.11		25227
50108	0.000	9	1554	-11757.1	-468.53	80.74	-.-	-1493	-4.97	-37.89		25390
				-0.155	-0.104	0.001		-0.201	-2.73	-24.11		25227
	0.978	9	1554	-11829.7	-136.11	86.55	-.-	-5167	-4.24	-33.45		25386
				-0.156	-0.030	0.001		-0.171	-3.52	-28.91		25222
50109	0.000	9	1554	-11829.7	-136.11	86.54	-.-	-5167	-4.24	-33.45		25386
				-0.156	-0.030	0.001		-0.171	-3.52	-28.90		25222
	0.978	9	1554	-11902.3	197.31	92.33	-.-	3586	-4.40	-34.53		25379
				-0.157	0.044	0.001		-0.177	-3.40	-28.22		25215
50110	0.000	9	1554	-11902.3	197.30	92.33	-.-	3586	-4.40	-34.53		25379
				-0.157	0.044	0.001		-0.177	-3.40	-28.22		25215
	0.978	9	1554	-11974.9	530.58	98.10	-.-	1342	-5.19	-39.43		25370
				-0.158	0.118	0.001		-0.210	-2.65	-23.75		25207
50111	0.000	9	1554	-11974.9	530.58	98.09	-.-	1342	-5.19	-39.43		25370
				-0.158	0.118	0.001		-0.210	-2.65	-23.75		25207
	0.978	9	1554	-12047.5	862.19	103.83	-.-	831.8	-5.97	-44.33		25359
				-0.159	0.191	0.001		-0.243	-1.90	-19.32		25197
50112	0.000	9	1554	-12047.6	862.18	103.83	-.-	831.8	-5.97	-44.33		25359
				-0.159	0.191	0.001		-0.243	-1.90	-19.32		25197
	0.978	9	1554	-12120.2	1191.14	109.55	-.-	606.5	-6.74	-49.20		25346
				-0.160	0.264	0.001		-0.275	-1.15	-14.94		25186
50113	0.000	9	1554	-12120.3	1191.13	109.55	-.-	606.6	-6.74	-49.21		25346
				-0.160	0.264	0.001		-0.275	-1.15	-14.94		25186
	0.978	9	1554	-12189.8	1516.06	115.26	-.-	480.2	-7.49	-54.02		25346
				-0.162	0.337	0.002		-0.307	-0.41	-10.62		25182
50114	0.000	9	1554	-12189.9	1516.03	115.26	-.-	480.2	-7.49	-54.02		25346
				-0.162	0.337	0.002		-0.307	-0.41	-10.62		25182
	0.978	9	1554	-12263.5	1835.30	120.96	-99106	398.3	-8.24	-58.89		23137
				-0.163	0.409	0.002		-0.339	0.00	-6.28		24435
50115	0.000	9	1554	-12263.6	1835.36	120.96	-99107	398.3	-8.24	-58.89		23136
				-0.163	0.409	0.002		-0.339	0.00	-6.28		24435
	0.978	9	1554	-12335.6	2147.98	126.65	-85837	326.8	-9.06	-64.20		18400
				-0.162	0.495	0.002		-0.376	0.00	-0.55		22302
50116	0.000	9	1554	-12335.8	2147.99	126.64	-85842	326.8	-9.06	-64.20		18400
				-0.162	0.495	0.002		-0.376	0.00	-0.55		22302
	0.978	9	1554	-12408.2	2452.57	132.35	-72270	259.6	-10.01	-70.13		15419
				-0.157	0.604	0.002		-0.417	0.00	7.41		20258
50117	0.000	9	1554	-12408.4	2452.15	132.31	-72312	259.7	-10.01	-70.12		15422
				-0.157	0.604	0.002		-0.417	0.00	7.39		20261
	0.978	9	1554	-12481.0	2747.60	138.05	-58538	197.5	-11.07	-76.66		13685
				-0.146	0.740	0.002		-0.465	0.00	18.21		18368

Røydalen\_NORD\_GSR

**Nonlinear Stresses**

Beam	x[m]	SNo	LC	Ni [kN] ε-θ	Myi [kNm] ky	Mzi [kNm] kz	yn [mm] fact	zn [mm] ε	σ-min [MPa]	σ-s [MPa]	σ-t [MPa]	Ey-eff [N/mm2]
				[o/oo]	[1/km]	[1/km]	[-]	[o/oo]	σ-max [MPa]	σ-s [MPa]	σ-t [MPa]	Ez-eff [N/mm2]
50118	0.000	9	1554	-12481.3	2746.49	137.99	-58617	197.7	-11.07	-76.63		13690
				-0.146	0.739	0.002		-0.465	0.00	18.16		18376
	0.978	9	1554	-12553.8	3030.10	143.73	-44743	141.5	-12.24	-83.69		12745
				-0.128	0.906	0.003		-0.518	0.00	32.39		16655
50119	0.000	9	1554	-12554.2	3028.62	143.66	-44840	141.8	-12.24	-83.65		12749
				-0.128	0.905	0.003		-0.518	0.00	32.30		16665
	0.978	9	1554	-12625.9	3296.01	149.31	-31257	92.7	-13.50	-91.01		12267
				-0.102	1.103	0.003		-0.576	0.00	50.10		15158
50120	0.000	9	1554	-12626.4	3295.10	149.28	-31319	92.9	-13.49	-90.98		12268
				-0.102	1.102	0.003		-0.576	0.00	50.02		15164
	0.978	9	1554	-12691.6	3540.78	154.76	-18623	52.1	-14.76	-98.24		12024
				-0.069	1.322	0.004		-0.637	0.00	70.70		13908

**Maximum Stresses and Checked Limits**

Mat Check or Criterion	Value	Limit	Unit	Level	LC	Beam	x[m]
2 Longitud. compressive stress	σ-x	-98.24	MPa		1554	50120	0.978
Longitud. tensile stress	σ+x	103.27	MPa		1554	50098	0.000
5 Longitud. compressive stress	σ-x	-14.98	MPa		1554	50098	0.000
Longitud. tensile stress	σ+x	0.00	MPa		1554	50072	0.000

Plastic strains are stored in database

Deviation of Moments	0.008
Deviation of Forces	0.001
Deviation of Forces	0.000
Minimum stiffness	0.010
Maximum stiffness	4.000
Crisfield faktors	-0.080
	0.800

**Longitudinal Reinforcements - Design case No. 1554**

Beam	x[m]	SNo	ρ [o/o]	As1 [cm2]	vm [m]	As1-0 [cm2]	As1-1 [cm2]	As1-2 [cm2]	As1-3 [cm2]	As1-4 [cm2]	As1-5 [cm2]
50001	0.000	9	0.35	102.82		15.84	41.23	41.23	4.52		
50001	1.000	9	0.35	102.82		15.84	41.23	41.23	4.52		
50002	0.000	9	0.35	102.82		15.84	41.23	41.23	4.52		
50002	1.000	9	0.35	102.82		15.84	41.23	41.23	4.52		
50003	0.000	9	0.35	102.82		15.84	41.23	41.23	4.52		
50003	1.000	9	0.35	102.82		15.84	41.23	41.23	4.52		
50004	0.000	9	0.35	102.82		15.84	41.23	41.23	4.52		
50004	1.000	9	0.35	102.82		15.84	41.23	41.23	4.52		
50005	0.000	9	0.35	102.82		15.84	41.23	41.23	4.52		
50005	1.000	9	0.35	102.82		15.84	41.23	41.23	4.52		
50006	0.000	9	0.35	102.82		15.84	41.23	41.23	4.52		
50006	1.000	9	0.35	102.82		15.84	41.23	41.23	4.52		
50007	0.000	9	0.35	102.82		15.84	41.23	41.23	4.52		
50007	1.000	9	0.35	102.82		15.84	41.23	41.23	4.52		
50008	0.000	9	0.35	102.82		15.84	41.23	41.23	4.52		
50008	1.000	9	0.35	102.82		15.84	41.23	41.23	4.52		
50009	0.000	9	0.35	102.82		15.84	41.23	41.23	4.52		
50009	1.000	9	0.35	102.82		15.84	41.23	41.23	4.52		
50010	0.000	9	0.35	102.82		15.84	41.23	41.23	4.52		
50010	1.000	9	0.35	102.82		15.84	41.23	41.23	4.52		
50011	0.000	9	0.35	102.82		15.84	41.23	41.23	4.52		

Røydalen\_NORD\_GSR

Longitudinal Reinforcements - Design case No. 1554

Beam	x[m]	SNo	$\rho$ [o/o]	As1 [cm2]	vm [m]	As1-0 [cm2]	As1-1 [cm2]	As1-2 [cm2]	As1-3 [cm2]	As1-4 [cm2]	As1-5 [cm2]
50011	1.000	9	0.35	102.82		15.84	41.23	41.23	4.52		
50012	0.000	9	0.35	102.82		15.84	41.23	41.23	4.52		
50012	1.000	9	0.35	102.82		15.84	41.23	41.23	4.52		
50013	0.000	9	0.35	102.82		15.84	41.23	41.23	4.52		
50013	1.000	9	0.35	102.82		15.84	41.23	41.23	4.52		
50014	0.000	9	0.35	102.82		15.84	41.23	41.23	4.52		
50014	1.000	9	0.35	102.82		15.84	41.23	41.23	4.52		
50015	0.000	9	0.35	102.82		15.84	41.23	41.23	4.52		
50015	1.000	9	0.35	102.82		15.84	41.23	41.23	4.52		
50016	0.000	9	0.35	102.82		15.84	41.23	41.23	4.52		
50016	1.000	9	0.35	102.82		15.84	41.23	41.23	4.52		
50017	0.000	9	0.35	102.82		15.84	41.23	41.23	4.52		
50017	1.000	9	0.35	102.82		15.84	41.23	41.23	4.52		
50018	0.000	9	0.36	107.22		15.84	45.63	41.23	4.52		
50018	1.000	9	0.36	107.23		15.84	45.64	41.23	4.52		
50019	0.000	9	0.36	107.23		15.84	45.64	41.23	4.52		
50019	1.000	9	0.36	107.25		15.84	44.58	42.31	4.52		
50020	0.000	9	0.36	107.25		15.84	44.58	42.32	4.52		
50020	1.000	9	0.35	102.82		15.84	41.23	41.23	4.52		
50021	0.000	9	0.35	102.82		15.84	41.23	41.23	4.52		
50021	1.000	9	0.35	102.82		15.84	41.23	41.23	4.52		
50022	0.000	9	0.35	102.82		15.84	41.23	41.23	4.52		
50022	1.000	9	0.35	102.82		15.84	41.23	41.23	4.52		
50023	0.000	9	0.35	102.82		15.84	41.23	41.23	4.52		
50023	1.000	9	0.35	102.82		15.84	41.23	41.23	4.52		
50024	0.000	9	0.35	102.82		15.84	41.23	41.23	4.52		
50024	1.000	9	0.35	102.82		15.84	41.23	41.23	4.52		
50025	0.000	9	0.35	102.82		15.84	41.23	41.23	4.52		
50025	1.000	9	0.35	102.82		15.84	41.23	41.23	4.52		
50026	0.000	9	0.35	102.82		15.84	41.23	41.23	4.52		
50026	1.000	9	0.35	102.82		15.84	41.23	41.23	4.52		
50027	0.000	9	0.35	102.82		15.84	41.23	41.23	4.52		
50027	1.000	9	0.35	102.82		15.84	41.23	41.23	4.52		
50028	0.000	9	0.35	102.82		15.84	41.23	41.23	4.52		
50028	1.000	9	0.35	102.82		15.84	41.23	41.23	4.52		
50029	0.000	9	0.35	102.82		15.84	41.23	41.23	4.52		
50029	1.000	9	0.35	102.82		15.84	41.23	41.23	4.52		
50030	0.000	9	0.35	102.82		15.84	41.23	41.23	4.52		
50030	1.000	9	0.35	102.82		15.84	41.23	41.23	4.52		
50031	0.000	9	0.35	102.82		15.84	41.23	41.23	4.52		
50031	1.000	9	0.35	102.82		15.84	41.23	41.23	4.52		
50032	0.000	9	0.35	102.82		15.84	41.23	41.23	4.52		
50032	1.000	9	0.35	102.82		15.84	41.23	41.23	4.52		
50033	0.000	9	0.35	102.82		15.84	41.23	41.23	4.52		
50033	1.000	9	0.35	102.82		15.84	41.23	41.23	4.52		
50034	0.000	9	0.35	102.82		15.84	41.23	41.23	4.52		
50034	1.000	9	0.35	102.82		15.84	41.23	41.23	4.52		
50035	0.000	9	0.35	102.82		15.84	41.23	41.23	4.52		
50035	1.000	9	0.35	102.82		15.84	41.23	41.23	4.52		
50036	0.000	9	0.35	102.82		15.84	41.23	41.23	4.52		
50036	1.000	9	0.35	102.82		15.84	41.23	41.23	4.52		
50037	0.000	9	0.35	102.82		15.84	41.23	41.23	4.52		
50037	1.000	9	0.35	102.82		15.84	41.23	41.23	4.52		
50038	0.000	9	0.35	102.82		15.84	41.23	41.23	4.52		

Røydalen\_NORD\_GSR

Longitudinal Reinforcements - Design case No. 1554

Beam	x[m]	SNo	$\rho$ [o/o]	As1 [cm2]	vm [m]	As1-0 [cm2]	As1-1 [cm2]	As1-2 [cm2]	As1-3 [cm2]	As1-4 [cm2]	As1-5 [cm2]
50038	1.000	9	0.35	102.82		15.84	41.23	41.23	4.52		
50039	0.000	9	0.35	102.82		15.84	41.23	41.23	4.52		
50039	1.000	9	0.35	102.82		15.84	41.23	41.23	4.52		
50040	0.000	9	0.35	102.82		15.84	41.23	41.23	4.52		
50040	1.000	9	0.35	102.82		15.84	41.23	41.23	4.52		
50041	0.000	9	0.35	102.82		15.84	41.23	41.23	4.52		
50041	1.000	9	0.35	102.82		15.84	41.23	41.23	4.52		
50042	0.000	9	0.35	102.82		15.84	41.23	41.23	4.52		
50042	1.000	9	0.35	102.82		15.84	41.23	41.23	4.52		
50043	0.000	9	0.35	102.82		15.84	41.23	41.23	4.52		
50043	1.000	9	0.35	102.82		15.84	41.23	41.23	4.52		
50044	0.000	9	0.36	105.97		15.84	44.38	41.23	4.52		
50044	1.000	9	0.36	105.89		15.84	44.30	41.23	4.52		
50045	0.000	9	0.36	105.89		15.84	44.30	41.23	4.52		
50045	1.000	9	0.36	106.06		15.84	44.47	41.23	4.52		
50046	0.000	9	0.36	106.06		15.84	44.48	41.23	4.52		
50046	1.000	9	0.36	106.74		15.84	45.15	41.23	4.52		
50047	0.000	9	0.36	106.74		15.84	45.15	41.23	4.52		
50047	1.000	9	0.36	106.84		15.84	45.25	41.23	4.52		
50048	0.000	9	0.36	106.84		15.84	45.25	41.23	4.52		
50048	1.000	9	0.35	102.82		15.84	41.23	41.23	4.52		
50049	0.000	9	0.35	102.82		15.84	41.23	41.23	4.52		
50049	1.000	9	0.35	102.82		15.84	41.23	41.23	4.52		
50050	0.000	9	0.35	102.82		15.84	41.23	41.23	4.52		
50050	1.000	9	0.35	102.82		15.84	41.23	41.23	4.52		
50051	0.000	9	0.35	102.82		15.84	41.23	41.23	4.52		
50051	1.000	9	0.35	102.82		15.84	41.23	41.23	4.52		
50052	0.000	9	0.35	102.82		15.84	41.23	41.23	4.52		
50052	1.000	9	0.35	102.82		15.84	41.23	41.23	4.52		
50053	0.000	9	0.35	102.82		15.84	41.23	41.23	4.52		
50053	1.000	9	0.35	102.82		15.84	41.23	41.23	4.52		
50054	0.000	9	0.35	102.82		15.84	41.23	41.23	4.52		
50054	1.000	9	0.35	102.82		15.84	41.23	41.23	4.52		
50055	0.000	9	0.35	102.82		15.84	41.23	41.23	4.52		
50055	1.000	9	0.35	102.82		15.84	41.23	41.23	4.52		
50056	0.000	9	0.35	102.82		15.84	41.23	41.23	4.52		
50056	1.000	9	0.35	102.82		15.84	41.23	41.23	4.52		
50057	0.000	9	0.35	102.82		15.84	41.23	41.23	4.52		
50057	1.000	9	0.35	102.82		15.84	41.23	41.23	4.52		
50058	0.000	9	0.35	102.82		15.84	41.23	41.23	4.52		
50058	1.000	9	0.35	102.82		15.84	41.23	41.23	4.52		
50059	0.000	9	0.35	102.82		15.84	41.23	41.23	4.52		
50059	1.000	9	0.35	102.82		15.84	41.23	41.23	4.52		
50060	0.000	9	0.35	102.82		15.84	41.23	41.23	4.52		
50060	1.000	9	0.35	102.82		15.84	41.23	41.23	4.52		
50061	0.000	9	0.35	102.82		15.84	41.23	41.23	4.52		
50061	1.000	9	0.35	102.82		15.84	41.23	41.23	4.52		
50062	0.000	9	0.35	102.82		15.84	41.23	41.23	4.52		
50062	1.000	9	0.35	102.82		15.84	41.23	41.23	4.52		
50063	0.000	9	0.35	102.82		15.84	41.23	41.23	4.52		
50063	1.000	9	0.35	102.82		15.84	41.23	41.23	4.52		
50064	0.000	9	0.35	102.82		15.84	41.23	41.23	4.52		
50064	1.000	9	0.35	102.82		15.84	41.23	41.23	4.52		
50065	0.000	9	0.35	102.82		15.84	41.23	41.23	4.52		

Røydalen\_NORD\_GSR

Longitudinal Reinforcements - Design case No. 1554

Beam	x[m]	SNo	$\rho$ [o/o]	As1 [cm2]	vm [m]	As1-0 [cm2]	As1-1 [cm2]	As1-2 [cm2]	As1-3 [cm2]	As1-4 [cm2]	As1-5 [cm2]
50065	1.000	9	0.35	102.82		15.84	41.23	41.23	4.52		
50066	0.000	9	0.35	102.82		15.84	41.23	41.23	4.52		
50066	1.000	9	0.35	102.82		15.84	41.23	41.23	4.52		
50067	0.000	9	0.35	102.82		15.84	41.23	41.23	4.52		
50067	1.000	9	0.35	104.91		15.84	41.50	43.05	4.52		
50068	0.000	9	0.35	104.91		15.84	41.50	43.05	4.52		
50068	1.000	9	0.35	104.75		15.84	41.53	42.86	4.52		
50069	0.000	9	0.35	104.75		15.84	41.53	42.86	4.52		
50069	1.000	9	0.35	104.59		15.84	41.51	42.73	4.52		
50070	0.000	9	0.35	104.59		15.84	41.51	42.73	4.52		
50070	1.000	9	0.35	102.82		15.84	41.23	41.23	4.52		
50071	0.000	9	0.36	105.63		15.84	44.04	41.23	4.52		
50071	1.000	9	0.36	105.77		15.84	44.18	41.23	4.52		
50072	0.000	9	0.36	105.77		15.84	44.18	41.23	4.52		
50072	1.000	9	0.36	105.59		15.84	44.00	41.23	4.52		
50073	0.000	9	0.36	105.59		15.84	44.00	41.23	4.52		
50073	1.000	9	0.36	105.38		15.84	43.79	41.23	4.52		
50074	0.000	9	0.36	105.38		15.84	43.79	41.23	4.52		
50074	1.000	9	0.36	105.40		15.84	43.81	41.23	4.52		
50075	0.000	9	0.36	105.40		15.84	43.81	41.23	4.52		
50075	1.000	9	0.36	106.30		15.84	44.71	41.23	4.52		
50076	0.000	9	0.36	106.30		15.84	44.71	41.23	4.52		
50076	1.000	9	0.36	106.42		15.84	43.86	42.21	4.52		
50077	0.000	9	0.36	106.42		15.84	43.86	42.21	4.52		
50077	1.000	9	0.35	102.82		15.84	41.23	41.23	4.52		
50078	0.000	9	0.35	102.82		15.84	41.23	41.23	4.52		
50078	1.000	9	0.35	102.82		15.84	41.23	41.23	4.52		
50079	0.000	9	0.35	102.82		15.84	41.23	41.23	4.52		
50079	1.000	9	0.35	102.82		15.84	41.23	41.23	4.52		
50080	0.000	9	0.35	102.82		15.84	41.23	41.23	4.52		
50080	1.000	9	0.35	102.82		15.84	41.23	41.23	4.52		
50081	0.000	9	0.35	102.82		15.84	41.23	41.23	4.52		
50081	1.000	9	0.35	102.82		15.84	41.23	41.23	4.52		
50082	0.000	9	0.35	102.82		15.84	41.23	41.23	4.52		
50082	1.000	9	0.35	102.82		15.84	41.23	41.23	4.52		
50083	0.000	9	0.35	102.82		15.84	41.23	41.23	4.52		
50083	1.000	9	0.35	102.82		15.84	41.23	41.23	4.52		
50084	0.000	9	0.35	102.82		15.84	41.23	41.23	4.52		
50084	1.000	9	0.35	102.82		15.84	41.23	41.23	4.52		
50085	0.000	9	0.35	102.82		15.84	41.23	41.23	4.52		
50085	1.000	9	0.35	102.82		15.84	41.23	41.23	4.52		
50086	0.000	9	0.35	102.82		15.84	41.23	41.23	4.52		
50086	1.000	9	0.35	102.82		15.84	41.23	41.23	4.52		
50087	0.000	9	0.35	102.82		15.84	41.23	41.23	4.52		
50087	1.000	9	0.35	102.82		15.84	41.23	41.23	4.52		
50088	0.000	9	0.35	102.82		15.84	41.23	41.23	4.52		
50088	1.000	9	0.35	102.82		15.84	41.23	41.23	4.52		
50089	0.000	9	0.35	102.82		15.84	41.23	41.23	4.52		
50089	1.000	9	0.35	102.82		15.84	41.23	41.23	4.52		
50090	0.000	9	0.35	102.82		15.84	41.23	41.23	4.52		
50090	1.000	9	0.35	102.82		15.84	41.23	41.23	4.52		
50091	0.000	9	0.35	102.82		15.84	41.23	41.23	4.52		
50091	1.000	9	0.35	104.88		15.84	41.82	42.70	4.52		
50092	0.000	9	0.35	104.88		15.84	41.82	42.69	4.52		

Røydalen\_NORD\_GSR

**Longitudinal Reinforcements - Design case No. 1554**

Beam	x[m]	SNo	$\rho$ [o/o]	As1 [cm2]	vm [m]	As1-0 [cm2]	As1-1 [cm2]	As1-2 [cm2]	As1-3 [cm2]	As1-4 [cm2]	As1-5 [cm2]
50092	1.000	9	0.35	104.68		15.84	41.86	42.46	4.52		
50093	0.000	9	0.35	104.68		15.84	41.86	42.46	4.52		
50093	1.000	9	0.35	102.82		15.84	41.23	41.23	4.52		
50094	0.000	9	0.35	102.82		15.84	41.23	41.23	4.52		
50094	1.000	9	0.35	104.17		15.84	41.23	42.58	4.52		
50095	0.000	9	0.35	104.17		15.84	41.23	42.58	4.52		
50095	1.000	9	0.35	103.32		15.84	41.23	41.73	4.52		
50096	0.000	9	0.35	103.32		15.84	41.23	41.73	4.52		
50096	1.000	9	0.35	103.91		15.84	41.23	42.32	4.52		
50097	0.000	9	0.35	103.91		15.84	41.23	42.33	4.52		
50097	1.000	9	0.35	103.94		15.84	41.23	42.35	4.52		
50098	0.000	9	0.35	102.95		15.84	41.36	41.23	4.52		
50098	0.978	9	0.35	103.00		15.84	41.41	41.23	4.52		
50099	0.000	9	0.35	103.00		15.84	41.41	41.23	4.52		
50099	0.978	9	0.35	103.06		15.84	41.47	41.23	4.52		
50100	0.000	9	0.35	103.06		15.84	41.47	41.23	4.52		
50100	0.978	9	0.35	103.13		15.84	41.54	41.23	4.52		
50101	0.000	9	0.35	103.13		15.84	41.54	41.23	4.52		
50101	0.978	9	0.35	103.13		15.84	41.54	41.23	4.52		
50102	0.000	9	0.35	103.13		15.84	41.54	41.23	4.52		
50102	0.978	9	0.35	103.31		15.84	41.72	41.23	4.52		
50103	0.000	9	0.35	103.31		15.84	41.72	41.23	4.52		
50103	0.978	9	0.35	103.43		15.84	41.84	41.23	4.52		
50104	0.000	9	0.35	103.43		15.84	41.84	41.23	4.52		
50104	0.978	9	0.35	103.56		15.84	41.77	41.44	4.52		
50105	0.000	9	0.35	103.56		15.84	41.77	41.43	4.52		
50105	0.978	9	0.35	102.82		15.84	41.23	41.23	4.52		
50106	0.000	9	0.35	102.82		15.84	41.23	41.23	4.52		
50106	0.978	9	0.35	102.82		15.84	41.23	41.23	4.52		
50107	0.000	9	0.35	102.82		15.84	41.23	41.23	4.52		
50107	0.978	9	0.35	102.82		15.84	41.23	41.23	4.52		
50108	0.000	9	0.35	102.82		15.84	41.23	41.23	4.52		
50108	0.978	9	0.35	102.82		15.84	41.23	41.23	4.52		
50109	0.000	9	0.35	102.82		15.84	41.23	41.23	4.52		
50109	0.978	9	0.35	102.82		15.84	41.23	41.23	4.52		
50110	0.000	9	0.35	102.82		15.84	41.23	41.23	4.52		
50110	0.978	9	0.35	102.82		15.84	41.23	41.23	4.52		
50111	0.000	9	0.35	102.82		15.84	41.23	41.23	4.52		
50111	0.978	9	0.35	102.82		15.84	41.23	41.23	4.52		
50112	0.000	9	0.35	102.82		15.84	41.23	41.23	4.52		
50112	0.978	9	0.35	102.82		15.84	41.23	41.23	4.52		
50113	0.000	9	0.35	102.82		15.84	41.23	41.23	4.52		
50113	0.978	9	0.35	104.11		15.84	41.68	42.07	4.52		
50114	0.000	9	0.35	104.11		15.84	41.68	42.07	4.52		
50114	0.978	9	0.35	104.03		15.84	41.23	42.44	4.52		
50115	0.000	9	0.35	104.03		15.84	41.23	42.44	4.52		
50115	0.978	9	0.35	103.85		15.84	41.23	42.27	4.52		
50116	0.000	9	0.35	103.86		15.84	41.23	42.27	4.52		
50116	0.978	9	0.35	103.76		15.84	41.23	42.17	4.52		
50117	0.000	9	0.35	103.76		15.84	41.23	42.17	4.52		
50117	0.978	9	0.35	103.86		15.84	41.23	42.27	4.52		
50118	0.000	9	0.35	103.86		15.84	41.23	42.27	4.52		
50118	0.978	9	0.35	103.48		15.84	41.23	41.89	4.52		
50119	0.000	9	0.35	103.48		15.84	41.23	41.89	4.52		



Røydalen\_NORD\_GSR

**Longitudinal Reinforcements - Design case No. 1554**

Beam	x[m]	SNo	$\rho$ [o/o]	As1 [cm2]	vm [m]	As1-0 [cm2]	As1-1 [cm2]	As1-2 [cm2]	As1-3 [cm2]	As1-4 [cm2]	As1-5 [cm2]
50119	0.978	9	0.35	103.27		15.84	41.23	41.69	4.52		
50120	0.000	9	0.35	103.27		15.84	41.23	41.68	4.52		
50120	0.978	9	0.35	103.78		15.84	41.23	42.19	4.52		

Note: Layer includes reinforcements for torsion if followed by T

Note: Layer has only compression reinforcements if followed by a quote

**Statistic nonlinear effects Loadcase 1554**

Statistic nonlinear effects of spring elements: no of elem.: 16  
 Number of longitudinal springs: 16  
 Number of torsional springs: 0  
 No nonlinear effects detected

Statistic beam elements: number of checked elements : 120  
 Number of yielding elements .....[DEHN KSV PL/PLD]: 0  
 Maximum plasticity value [1.00=just starting to yield]: 1.000  
 =difference plasticity without value of primary loadcase