



University of
Stavanger

Faculty of Science and Technology

MASTER'S THESIS

Study program/ Specialization: Master of Science Petroleum Technology	Spring semester, 2015 Open
Writer: Ola Grav Skjåstad (Writer's signature)
Faculty supervisor: Bernt Aadnøy External supervisor(s): Sjur Usken and Henning Hansen	
Thesis title: "A New Method for Through Tubing Drilling"	
Credits (ECTS): 30 Points	
Key words: Feasibility study, new drilling concept, through tubing drilling, tractor, umbilical	Pages: 124 + enclosure: 34 Stavanger, 15.06.2015 Date/year

Preface

This is a Master's Thesis that has been prepared during the spring semester of 2015 at the Institute of Petroleum Technology at the University of Stavanger as part of my Master's Degree in Petroleum Engineering. The thesis is a discussion and exploration of the feasibility of a new method for through tubing drilling that has the potential of being safer and more cost effective than conventional methods. The new method is a concept by Henning Hansen and Aarbakke Innovation and the thesis was carried out in cooperation with them. I was free to explore this concept to lay a foundation for future development on my own terms. Henning Hansen provided the necessary information for a preliminary description and area of use of the concept for me to build upon. Aarbakke Innovation provided me with support from my external supervisor Sjur Usken who made sure that I never encountered any show stoppers so that I was self sufficient in my work.

The presumed background for the readers of this thesis is a higher technical education, preferably within the petroleum industry.

Institute of Petroleum Technology

University of Stavanger

Ola Grav Skjåstad

Spring 2015

Acknowledgment

I would like to thank my supervisor Bernt Aadnøy for his support, guidance and knowledge throughout the the Master´s Thesis work. The discussions and his availability have been a great help.

I would also like to express my gratitude for the support and guidance from Henning Hansen and Sjur Usken at Aarbakke Innovation. Henning provided all the required technical details for me to use as the foundation for the thesis. Sjur Usken provided me with excellent support, enthusiasm and pushed me to be just as enthusiastic.

Finally I would like to thank my father, Otto Skjåstad, who continually gave me invaluable support throughout the thesis work.

Ola Grav Skjåstad

Abstract

As the world energy needs rises, the demand for new oil and gas reserves will increase along with the need for increased recovery from existing reserves. Through tubing drilling is one method of accomplishing increased recovery. New laterals can be drilled from existing wells with the completion in place to access bypassed reservoirs that were too small or too difficult to access due to the additional drilling cost. Through tubing drilling methods can also be used to extend the life of a mature asset by producing another part of the reservoir.

Today, the conventional methods of accomplishing this are coiled tubing drilling or through tubing rotary drilling. Even though these are established methods in the industry, there is room for further development.

This thesis is the start of a feasibility study for a concept called UmbiliDrill. UmbiliDrill is an all-electrical drilling system operated by a spool-able umbilical deployed from the surface. The system has the potential to drill these laterals more safely and cost effectively by being more accurate in the placement of the well in the reservoir, having more effective well paths and having the potential for a shorter operational timespan.

The feasibility is determined by evaluating the potential of UmbiliDrill, finding and evaluating available supporting technologies, evaluating how UmbiliDrill will function in an actual operation and evaluating if the system fulfills the design requirements to drill a well with respect to torque, drag, buckling and hydraulics.

The feasibility study revealed that UmbiliDrill has the potential of reducing risk, making it more safe and thereby more cost effective as a through tubing drilling system compared to conventional methods. The study also revealed that it can be an improved system for drilling into difficult bypassed and mature reservoirs. It is not limited by buckling and can always supply enough torque and weight on bit, thus it can drill further and with a more complex well path than conventional methods.

A few limitations to the drilling performance were discovered with regards to the hydraulics and hole cleaning and there is some uncertainty of some of the features of the system. However no show stoppers were identified. Based on this, further development of the system is recommended.

Contents

Preface	i
Acknowledgment	ii
Abstract	iii
1 Introduction	2
1.1 Background and objectives	2
1.2 Limitations	5
1.3 Approach	6
2 Theory and methods for calculating forces on a drill string	8
2.1 Torque and drag theory	8
2.1.1 Contact Friction	8
2.1.2 Maximum load location	9
2.1.3 Tool joint contribution	9
2.1.4 Torque	10

2.1.5	Drag	10
2.1.6	Buckling	13
2.2	Hydraulics Theory	15
2.2.1	Pressure loss in the fluid circulation system	15
2.2.2	Equivalent circulating density and the drilling window	17
2.2.3	Hole Cleaning	18
3	Through tubing drilling methods	21
3.1	Torque and Drag	22
3.2	Fluid hydraulics	23
3.3	Hole Stability	24
3.4	Equipment handling	25
4	Planning a through tubing drilling operation	28
4.1	Establishing a cost overview	28
4.2	Establishing objectives	29
4.3	Candidate well selection	30
4.4	Finalizing well trajectory	31
4.5	Pressure management and hole stability	31
4.6	Planning for completion	32

4.7	Choosing drilling method	32
4.8	Underbalanced drilling	33
4.9	Well control	34
5	UmbiliDrill	35
5.1	System Description	35
5.1.1	The drilling motor	36
5.1.2	Directional control system	36
5.1.3	The hydraulic drill collar	37
5.1.4	The umbilical	37
5.1.5	Sensors unit	39
5.2	The potential of UmbiliDrill	39
5.2.1	Torque and drag	39
5.2.2	Fluid hydraulics	41
5.2.3	Hole stability	41
5.2.4	Equipment handling	42
5.3	UmbiliDrill motivation	44
5.3.1	General	44
5.3.2	HSE and cost	44

5.3.3	Economic efficiency	45
5.3.4	Other areas of use	46
6	Technologies that support the UmbiliDrill concept	47
6.1	The Kolibomac concept	48
6.1.1	System Description	49
6.1.2	The inflatable packer, no-slip condition and tensile stress limits	51
6.2	The Anaconda system	56
6.2.1	System description	58
6.3	Fiberspar composite coiled tubing	61
6.4	Reelwell Drilling Method	63
6.4.1	System description	63
6.4.2	Benefits of the Reelwell Drilling Method	63
6.5	Nordhard Norwegian Hard Rock Drilling	67
6.5.1	General	67
6.5.2	Drilling system description	67
6.5.3	Use of a permanent magnet motor	68
7	Case Analysis	72
7.1	Introduction and summary of operation	72

7.2	Operational challenges	74
7.2.1	Maintain completion integrity	74
7.2.2	Directional drilling	76
7.2.3	Stuck pipe	76
7.2.4	Hole Cleaning	77
7.2.5	Formation integrity and stability	78
7.2.6	Drill string	80
7.3	Evaluation of sequence of operations in a through tubing drilling operation	80
7.4	Torque and drag calculations	83
7.4.1	General assumptions	83
7.4.2	Torque and drag calculation results for TTRD	86
7.4.3	Torque and drag calculation results for UmbiliDrill	86
7.4.4	Kolibomac inflatable packer no-slip and tensile stress limit	89
7.5	Hydraulics	91
7.5.1	General	91
7.5.2	Pressure loss and ECD in the TTRD fluid circulation system	92
7.5.3	Pressure loss and ECD in the UmbiliDrill circulation system	92
7.5.4	Hole cleaning performance for both systems	96

7.6	Motor estimates for UmbiliDrill	97
7.6.1	Re-scaling the Nordhard motor size to required size for UmbiliDrill	97
7.6.2	Motor power requirement estimates	97
8	Discussion of the UmbiliDrill system feasibility	99
8.1	General	99
8.2	Supporting technology	100
8.3	Technical complexity of UmbiliDrill and operational evaluation	101
8.3.1	General	101
8.3.2	The umbilical	102
8.3.3	Surface equipment	103
8.3.4	Permanent magnet motor	104
8.3.5	Implications and uncertainty of the operational evaluation	105
8.4	Explanation of results from the case analysis	106
8.4.1	General drilling performance and limiting factors of conventional TTRD	106
8.4.2	General drilling performance and limiting factors for UmbiliDrill	108
8.4.3	Drilling performance evaluation	111
9	Summary and conclusions	116
9.1	Summary of results and limitations	117

<i>CONTENTS</i>	1
9.2 Main conclusions	120
9.3 Recommendation for future work	123
List of figures	125
List of tables	127
Acronyms	130
Bibliography	132
A Conventional TTRD T&D Tables	137
B UmbiliDrill Torque and Drag Tables	140
C Conventional TTRD Hydraulics Tables	142
D UmbiliDrill Hydraulics Tables	144
E Fiber optic distributed sensing	147

Chapter 1

Introduction

1.1 Background and objectives

It is a well-known fact that drilling an offshore well is expensive. It is also a well-known fact that the oil industry is an unstable market with respect to the ever-changing value of oil and gas. With this in mind and taking into consideration the increase in the world energy needs, the following will be required:

- Less costly drilling operations
- Increased recovery of oil and gas

Today the average recovery rate of oil worldwide is 40 % and 47 % on the Norwegian Continental Shelf (NCS). Statoil aims for 60 % in the future (Statoil, 2014). The oil recovery rate is the percentage of produced oil from the total oil in place in the reservoir. To increase the recovery rate a step in the right direction is extending the life of mature reservoirs or to produce bypassed reservoirs that were too expensive to develop initially.

A method to accomplish this is Through Tubing Drilling (TTD). This is an established cost effective way of creating new laterals from an existing motherbore to access marginal pockets of

oil and gas that was initially not deemed commercially viable to produce. TTD overcomes the economic constraint of traditional lateral drilling, where the completion equipment is removed before sidetracking. With the completion equipment in place, a milling assembly and a whipstock is used to mill a window in the tubing, casing and cement from which a new lateral is drilled into the reservoir. A liner is run, cemented and perforated. All of this is done without removing any completion equipment, including the christmas tree or the down hole safety valve. The main principle of a TTD operation can be seen in fig. 1.1.

There are two methods of through tubing drilling:

- Coiled Tubing Through Tubing Drilling (CT TTD) or Coiled Tubing Drilling (CTD) for short
- Through Tubing Rotary Drilling (TTRD)

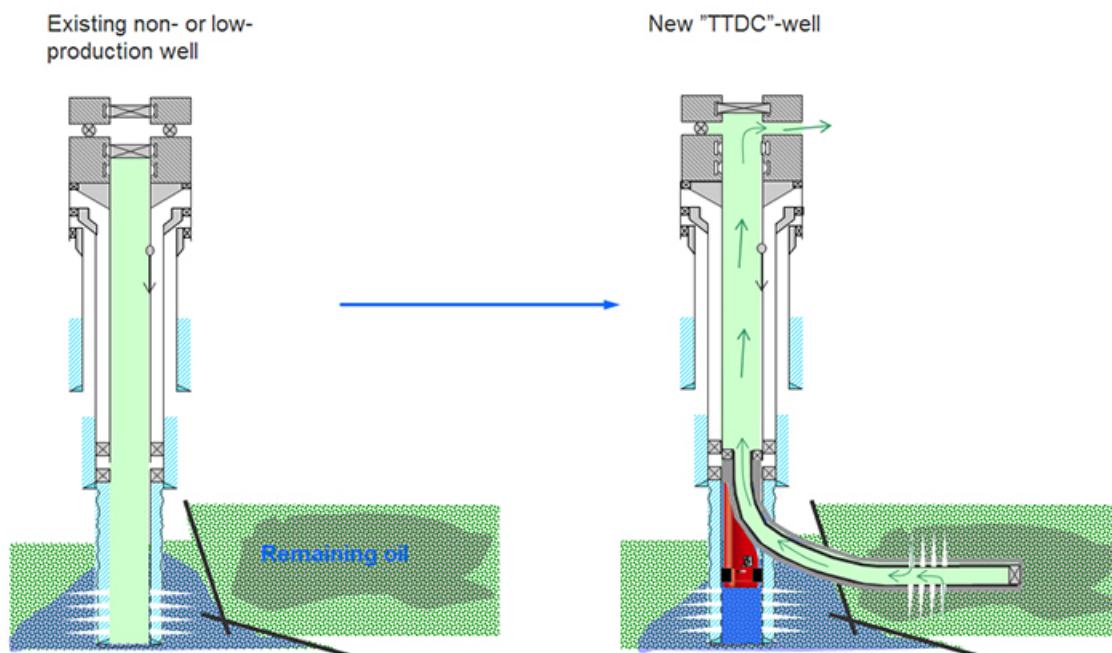

Figure 1.1: Visualization of a TTD operation (Statoil, 2007)

Through tubing drilling is still a new practice with relatively limited experience compared to other more traditional methods of drilling. There is a demand for a reliable and cost effective method to drill side tracks for increased oil recovery or accessing bypassed reservoirs when the well was originally constructed. E.g. there are currently 303 already known, but undeveloped

reservoirs across the United Kingdom Continental Shelf (UKCS) due to high cost or lack of technology to access bypassed pockets of hydrocarbons (Hansen, 2014). The possibility to develop these fields and increasing the life of mature fields is what through tubing drilling has the potential to deliver. The methods in place today can be improved upon. There are potential methods of drilling laterals more effectively, more safely and less costly.

The reservoirs were bypassed mainly because they are too small to make a profit when considering the investment costs for a oil well. For them to be productive requires a cost effective drilling method with high precision to accurately place the well in the most optimal location in the reservoir for optimal production rates. Another reason for drilling a through tubing well is to convert a mature well into a multilateral to compensate for high water cuts and low draw down pressures.

A through tubing operation will increase the chance of destroying the in-place completion and will cause tubing wear due to rotation of the drill string, at least for TTRD. Mature reservoirs are also are prone to hole stability issues and are very sensitive to contamination from lost circulation. Through tubing drilling wells can therefore be seen as a risky investment both to the new lateral and the motherbore. Not to mention that production has to be stopped in the motherbore while the new lateral is under construction. Therefore there is demand for innovation in the TTD market.

A proposal for a method that can address these points is an all-electrical drilling machine operated by a spool-able umbilical deployed from surface called UmbiliDrill. This is a concept introduced by Henning Hansen and Aarbakke Innovation. The technology and method of drilling is analogous to coiled tubing drilling. However, the intricacy of its design gives it a much higher potential with respect to operational risks of through tubing drilling operations and effective drilling.

UmbiliDrill is a theoretical concept at this stage and needs to be studied in detail to find evidence that support the feasibility of the concept.

The content of a feasibility study proposed by Aarbakke Innovation, is summarized here:

1. Overall system
2. Challenges identification and discussion
 - Hole cleaning
 - Getting stuck
 - Long length cuttings transport
 - Casing installation
 - Weak zone stabilization / sand control / inflow control methodology
3. Technologies existing and technologies to be developed
4. Technology partners
5. Cost and time estimates
6. Commercialization models

The initial feasibility for UmbiliDrill is explored in this thesis. The thesis will cover the three points below, which are based on the feasibility study goals by Aarbakke Innovation listed above:

- Identifying and evaluating the operational impact of UmbiliDrill
- Finding available technologies that can be used to support the UmbiliDrill feasibility and potential
- Evaluate UmbiliDrill with respect to the design and functional requirements that is needed to drill a well

1.2 Limitations

UmbiliDrill is a concept in a very early stage of development. This thesis is the first attempt to explore the vision of UmbiliDrill and its potential advantages and disadvantages compared to current methods. Naturally, this means there are a few limitations to what can be accomplished at this stage. There is currently no detailed information with regards to the system itself. Testing out the arguments for the feasibility is beyond the scope of this thesis.

The different components that make up the UmbiliDrill system will have to be pieced together using technologies that are available today, under development or were attempted to be developed in the past. Some technologies are more applicable than others and some technologies can be regarded as out dated.

Any conclusions made regarding advantages and disadvantages will be based on envisioning of how the UmbiliDrill system will behave during a TTD operation based on assumptions. The behavior of coiled tubing drilling and through tubing rotary drilling is well documented and is used as a basis for these assumptions. This behavior is also based on the technologies that are pieced together to form the building blocks of UmbiliDrill. The conclusions are therefore preliminary and not definite.

Other limitations can be found in the mathematical modeling and evaluation done in this thesis. All calculations are done using Microsoft Excel and models that are used in the industry. Naturally the results will not reflect a completely realistic scenario, but will be accurate enough to do a reasonable assessment of the UmbiliDrill concept at this stage.

1.3 Approach

The potential of UmbiliDrill is determined by exploring the conventional methods for through tubing drilling. The strengths and weaknesses of coiled tubing drilling and through tubing rotary drilling is described along with the process of planning a through tubing operation. This gives insight into the strengths and weaknesses the features of UmbiliDrill will exhibit in a through tubing drilling operation. These features are based on the assumed behavior of the individual components of UmbiliDrill.

The behavior of UmbiliDrill and its features are supported by established enabling technologies. These technologies are either entire systems that included many of the same features as UmbiliDrill or technologies that could be used as individual components of the system. The experience from the development, testing or the application in the field of these established

technologies serves as evidence for the potential of the UmbiliDrill features.

This experience and evidence for the potential of the UmbiliDrill features is used as a basis to evaluate how the system could solve operational challenges. It is also used as a basis to evaluate how the UmbiliDrill system would be used in an actual sequence of operations for a through tubing multilateral well.

Finally it will be determined if UmbiliDrill can meet the standard functional and design requirements to drill a well. The system will have to be able to handle the torque and drag. It needs to be able to supply sufficient weight on bit without buckling. The system will also need to handle the frictional pressures generated by the fluid flow rate dictated by the hole cleaning requirement while keeping the ECD inside the drilling window. This is done in parallel to an actual through tubing drilling operation using conventional methods. The two methods are compared to identify the differences between the methods.

Chapter 2

Theory and methods for calculating forces on a drill string

Before explaining the different TTD methods it is important to understand the fundamental forces that are experienced by the drill string during drilling. Understanding this will support the arguments made for the two methods. Advantages and disadvantages related to other abilities than drill string forces will be explained as well.

Knowing how far it is possible to drill will indicate important distinctions between the two methods. Calculating the forces and comparing them to their respective yield strength of the material under stress, i.e. the drill string, determines maximum drillable length.

2.1 Torque and drag theory

2.1.1 Contact Friction

One of the forces experienced by the drill string is the contact friction between the string and the wellbore. The contact friction is decided by the normal force and the frictional factor. The

normal force is the force that is perpendicular to the point of contact (Newton's Third Law). The frictional factor depends on the type of material and the geometry of the material that is in contact with each other. The contact friction will decide the required force to slide and/or rotate the drill string in the well bore.

2.1.2 Maximum load location

When calculating loads on a drill string it is important to know the location of the point that will experience the highest total stress. When e.g. a chain is hung from a fixed structure, the very top of the chain will experience the highest gravitational force because it will support the entire weight below the top point. It is the same when pulling and twisting the chain. This principle is the same when it comes to a drill string. Therefore, the very top of the drill string will be where tensional and torsional forces will be calculated from. However, bending stress and buckling will generally be largest farther down.

2.1.3 Tool joint contribution

The drill string is not completely uniform and is comprised of several pipes joined together in joints, called tool joints. The tool joints have larger diameters than the drill pipe and will be in contact with the hole before the drill pipe. The tool joints will contribute to most of the contact force in the well bore. However, in curves and in the horizontal plane the drill string will also come in contact with the well bore walls. To obtain the most correct and accurate value the forces need to be calculated for both diameters. The correct load values will be somewhere between the values obtained from using the two different diameters. A computer simulation program will have this distinction built in. (Skaugen, 2013)

2.1.4 Torque

The torque is the force moment required to rotate the drill string. The torque is decided by the contact friction in the well. It will need to be calculated as it will decide how far it is possible to drill horizontally into the reservoir. The torque will be greatest at the top of the string and the torsional yield strength at this point will be the limiting factor for how far the well can be drilled horizontally. When the torque generated by the well becomes greater than the torque yield limit, the drill string will be twisted apart.

2.1.5 Drag

The drag is the force required to hoist or lower the drill string out and in the borehole. It needs to be calculated to make sure that the axial forces at the top do not exceed the yield limit. When pulling a string in a vertical wellbore the rig is only lifting the strings static weight. However, when lifting a string from a curved or horizontal wellbore the string will slide along the annulus wall and cause friction. The friction adds to the weight of the string, hence the pulling force needs to be higher. If the pulling force exceeds the tensional yield strength or the lifting capacity of the rig the well has reached its maximum distance, at least in terms of the pulling force.

The lowering force is the force that the top of the string will experience when sliding it back into the wellbore after tripping. This force is lower than the pulling force as the friction in the curves contributes in the opposite direction of the direction of movement. If the well is perfectly vertical the pulling and lowering force will be identical to the lifting force. This will not be considered a limiting factor as the lowering force will always be lower than the pulling force.

There is a recent method of modeling torque and drag for in a 3D friction model (Aadnøy et al., 2010). This method incorporates the rotation of the drill string. This model is summarized in the equations below which also incorporates rotation of the string:

$$\Psi = \tan^{-1} \left(\frac{V_h}{V_r} \right) = \tan^{-1} \left(\frac{60V_h(m/s)}{2\pi N_r(rpm)r(m)} \right) \quad (2.1)$$

Ψ = angle between the axial and tangential velocity

V_r = tangential pipe speed

V_h = axial velocity

N_r = rotations per minute (rpm)

Torque and drag in straight pipe sections:

$$F_2 = F_1 + \beta w \Delta L \cos(\alpha) \pm \mu \beta w \Delta L \sin \alpha \sin \Psi \quad (2.2)$$

$$T = r \mu \beta w \Delta L \sin \alpha \cos \Psi \quad (2.3)$$

For curved pipe sections:

$$F_2 = F_1 + F_1 (e^{\pm \mu |\theta_2 - \theta_1|} - 1) \sin \Psi + \beta w \Delta L \left(\frac{\sin \alpha_2 - \sin \alpha_1}{\alpha_2 - \alpha_1} \right) \quad (2.4)$$

$$T = \mu r N = \mu r F_1 |\theta_2 - \theta_1| \cos \Psi \quad (2.5)$$

F_2 = Drag in section (kN)

F_1 = Drag in previous section (kN)

β = buoyancy factor

w = weight per meter (kN/m)

ΔL = Section length (m)

α = Curve angle (degrees) subscript 1 is the deepest angle and subscript 2 is the shallowest angle, see figure 2.1

μ = coefficient of friction

Φ = angle between the axial and tangential velocity

T = Torque (kNm)

r = pipe radius (m)

θ = curve angle (radians) subscript 1 is the deepest angle and subscript 2 is the shallowest angle, see figure 2.1

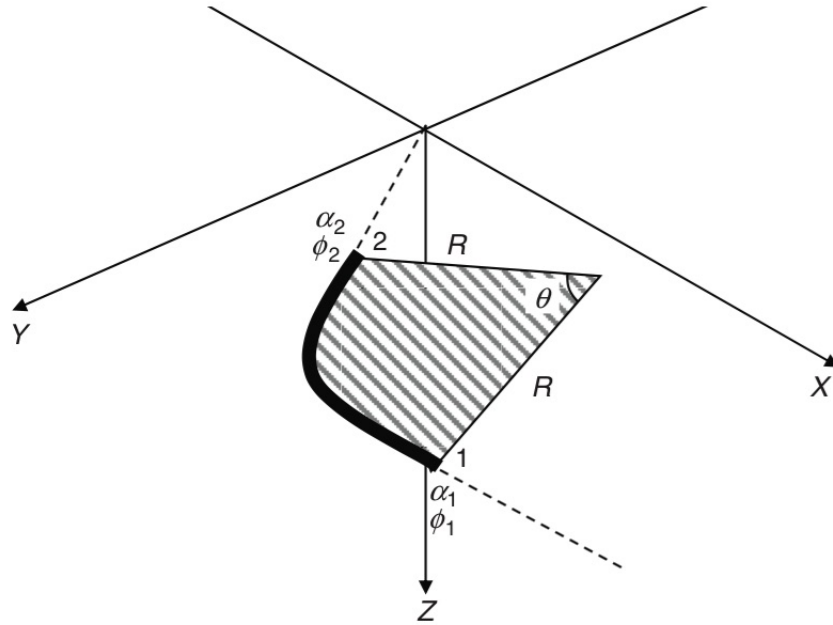

Figure 2.1: The Dogleg in 3D space

The Weight On Bit (WOB) will also contribute to the torque by the equation:

$$T = \frac{(D_b \times WOB \times \mu)}{36} \quad (2.6)$$

T = torque (ft-lbs)

D_b = bit diameter (in)

μ = friction coefficient

WOB = weight on bit (lbf)

2.1.6 Buckling

There are three scenarios where buckling in a string may occur:

- Compression of string in vertical section
- Compression of string in curved section
- Compression of string in inclined/straight section

When drilling deviated wells the string can start to buckle either at the end of the drill collars or in the horizontal section due to weight transfer to the bit and sliding force in the wellbore. In this scenario, the drill string is more likely to buckle in a horizontal or straight section than in a curved section. In a curved section, there will be a vertical and horizontal component that equals the compressive force. The vertical component will push the drill string into the well bore and will decrease the drill strings ability to buckle. The limiting factor here is not to exceed the critical buckling force in the horizontal section because the critical buckling force in the horizontal section will be lower than for the curved section.

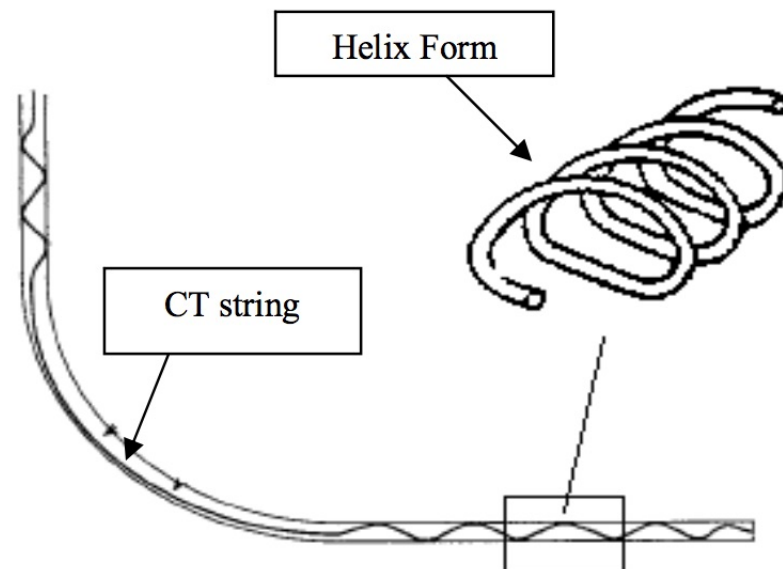

Figure 2.2: A sketch of the principles of helical buckling (Bawaked et al., 2008)

When compressing a string enough it will bend sinusoidal or even helically inside the wellbore and can cause the string to get stuck. Frictional force and the necessary weight on bit cannot exceed the helical buckling force. When the drill string is buckled helically it will lock up in the well bore and weight can no longer be transferred to the bit. The principal of helical buckling can be seen in fig. 2.2. There are a number of equations that attempt to model the sinusoidal and helical buckling force for the different well sections mentioned in the list above. The equations used in this thesis are described below. (Belayneh, 2006)

Inclined sinusoidal by Dawson and Paslay (1984):

$$F_{sin} = 2 \left(\frac{EIw \sin \alpha}{r} \right)^{0,5} \quad (2.7)$$

Curved helical by Mitchell (SPE29457):

$$F_{sin} = \frac{2EI k}{r} \left(1 + \sqrt{\frac{w \sin \alpha r}{EI k^2}} \right) \quad (2.8)$$

$$F_{hel} = 2,83 \times F_{sin} \quad (2.9)$$

Inclined/horizontal helical by Chen et al. average load (1989):

$$F_{hel} = 2\sqrt{2}(EI)^{0,5}(w \sin \alpha)^{0,5}(1/r)^{0,5} \quad (2.10)$$

$$F_{hel} = \sqrt{2} \times F_{Dawson-Paslay-Sinusoidal} \quad (2.11)$$

F_{sin} = sinusoidal buckling force

F_{hel} = helical buckling force

w = weight per unit length

E = Young's modulus of elasticity

α = angle of deviation

r = radial distance between the outer diameter of the drill string and the well bore

I = Moment of inertia

$k = 1 / R$ where R is the radius of the curve

2.2 Hydraulics Theory

2.2.1 Pressure loss in the fluid circulation system

When drilling a well, the pumping pressure required to circulate the drilling fluid must be known. The pressure is determined by the fluid friction in the well and the nozzle pressure loss. The required pumping pressure to circulate a given fluid at a given flow rate is determined by the frictional pressure loss in the well. The pressure dissipates through out its cycle and eventually equals zero when returning to surface. This means that the total pressure loss is equal to the initial pumping pressure. To calculate the total pressure loss across the well, the Drilling Data Handbook (DDH) can be used (Gabolde and Nguyen, 2006). The calculation is based on a Bingham fluid in turbulent flow and it takes into account the following:

- Lengths of the different sections
- The pressure loss in the nozzles
- Specific gravity of the drilling fluid
- Pressure loss in the surface equipment
- The drill pipes
- Drill collars
- The hole and drill collar annulus
- The hole and drill string annulus

Adding the pressure loss across all of these sections will give to total pressure loss across the well. As the length is an important factor, the pressure loss will need to be calculated with respect to the maximum length before reaching the burst pressure of the pipe. Depending on the different parameters of the drill string aside from length the total pressure loss may very well be a limiting factor.

The total pressure loss in the well can be calculated by using the tables in the DDH. Pressure loss in the drill string and Bottom Hole Assembly (BHA) are calculated with the equations:

$$P_{drillstring} = \left(\frac{\Delta s d^{0,8} Q^{1,8} \mu_p^{0,2}}{901,63 D^{4,8}} \right) \quad (2.12)$$

$$P_{annulus} = \left(\frac{\Delta s d^{0,8} Q^{1,8} \mu_p^{0,2}}{706,96 (D_o - D_i)^3} \right) \quad (2.13)$$

Δs = section length (m)

d = specific gravity (kg/l)

Q = flow rate (liter per minute)

μ_p = plastic viscosity

D_o = Open hole diameter (in)

D_i = Outside diameter string (in)

The pressure loss across the drill bit is calculated using the formula:

$$P = \frac{dQ^2}{2959,41 C^2 A^2} \quad (2.14)$$

P = Pressure loss (kPa)

d = specific gravity (kg/l)

Q = flow rate (lpm)

A = total nozzle area (in^2)

C = orifice coefficient = 0,95

The pressure loss in the drill string, BHA and across the bit is gives an accurate enough estimate of the total pressure loss in a circulation system for the purposes of this thesis. However, it is possible to account for the amount of cuttings in the annulus and how this affects the total pressure loss by increasing the overall density of the circulating fluid. This effect can be calculated using the formula:

$$d_{ann} = d_{init} + \frac{D_f^2 A_v (2,5 - d_{init})}{118,41Q - 60(D_f^2 - D_t^2) V_s} \quad (2.15)$$

A_v = rate of penetration (m/h)

d_{init} = initial specific gravity (kg/l)

d_{ann} = annular mud specific gravity

Q = flow rate (lpm)

V_s = rate of fall of cuttings (m/min)

D_f = Hole size (in)

D_t = pipe size (in)

2.2.2 Equivalent circulating density and the drilling window

In drilling of any well regardless of method a pressure is needed in the annulus in the open hole section to keep the formation from collapsing. This pressure also needs to be lower than the pressure required to fracture the formation. The pressure interval between the collapse pressure and fracturing pressure is called the drilling window. When drilling these pressures are converted into equivalent mud weights versus the true vertical hole depth. Pressures are converted into equivalent mud weights with the formula:

$$\rho = \frac{P}{gh} \quad (2.16)$$

ρ = Density (kg/l)

P = Pressure (bar)

g = Acceleration of gravity ($\frac{m}{s^2 \times 100}$)

h = True vertical depth (m)

The mud weights are chosen based on its ability to create enough hydrostatic pressure at the current depth to keep the hole from collapsing and stay below the fracturing pressure. However,

when the drilling mud is circulated, the bottom hole pressure is equal to the frictional pressure loss in the annulus plus the hydrostatic pressure of the drilling fluid. Including the annular frictional pressure loss with the mud weight results in what is called the equivalent circulating density.

$$\rho_{ECD} = \rho_{MW} + \frac{\Delta P_{ann}}{gh} \quad (2.17)$$

ρ_{ECD} = Equivalent Circulating Density (kg/l)

ρ_{MW} = Density of drilling fluid (kg/l)

ΔP_{ann} = Annular pressure loss (bar)

g = Acceleration of gravity ($\frac{m}{s^2 \times 100}$)

h = True vertical depth (m)

2.2.3 Hole Cleaning

Hole cleaning is a term that describes the transport of cuttings generated by the bit to the surface to keep the well from plugging. Hole cleaning is a key parameter when drilling a well. Keeping the hole clean depends on the rheological properties of the drilling fluid and the flow rate. Hole cleaning depends on the following controllable variables (Luo et al., 1994):

- Mud flow rate
- Rate of penetration (ROP)
- Mud rheology
- Mud flow regime
- Mud weight
- Hole angle
- Hole size

The minimum flow rate required for adequate hole cleaning is called the critical flow rate (CFR). According to the American Petroleum Institute standard for rheology and hydraulics of oil-well fluids (API, 2006) which is based on the paper by Luo et al. (1994), the CFR can be predicted by knowing the controllable variables listed above. A transport index is calculated using the equation:

$$TI = RF \times AF \times MW \quad (2.18)$$

TI = Transport index

RF = Rheology factor

AF = Angle factor

MW = Mud weight (s.g.)

The angle factor is found in table 2.1 and the rheology factor is found by inputting the plastic viscosity and yield point in figure 2.3a. The TI can be calculated and used along with the ROP in figure 2.3b to find the CFR.

Table 2.1: Angle factors for deviated holes Luo et al. (1994)

Hole Angle	Angle factors (AF)
25	1,51
30	1,39
35	1,31
40	1,24
45	1,18
50	1,14
55	1,10
60	1,07
65	1,05
70 - 80	1,02
80 - 90	1,0

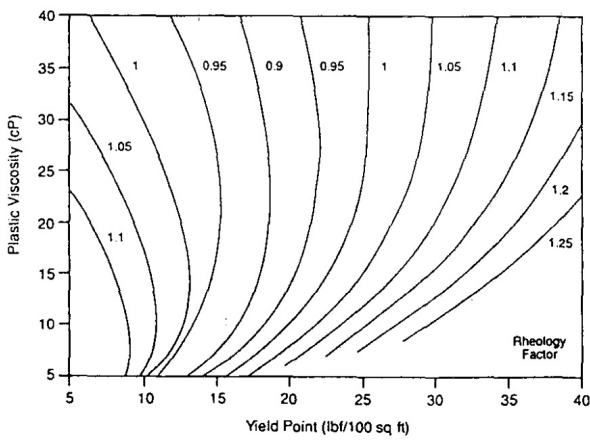

(a) Rheology Factor

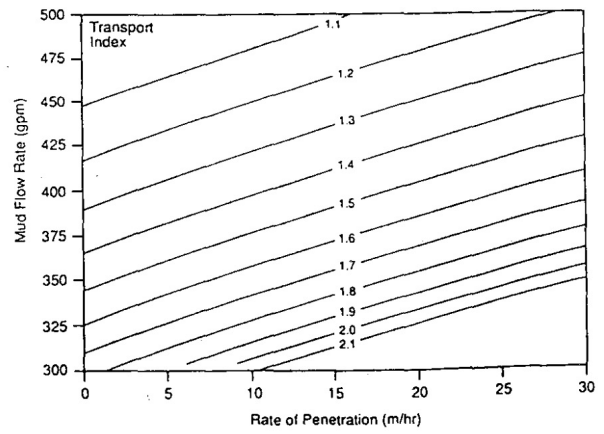

(b) Transport index

Figure 2.3: Hole Cleaning Charts for 8 1/2" holes (Luo et al., 1994)

Chapter 3

Through tubing drilling methods

Coiled Tubing Coiled tubing drilling is a method of drilling a hole using a continuous spooled rigid pipe with a down hole mud motor to drive the drilling machine. This method opens up some unique advantages as well as disadvantages when compared to conventional rotary drilling (Lenhart, 1994).

Through Tubing Rotary Drilling TTRD is the practice of using standard rotary drilling techniques to perform a TTD operation. It uses jointed pipes with a standard rig set up with a top drive, iron roughneck, pipe handling system, standard BOP and fluid system (Andersen, 2015a).

Four criteria are chosen to evaluate the advantages and disadvantages of the two methods. These criteria are based on the criteria used to chose between the two methods when planning a through tubing operation (see section 4.7):

- Torque and drag
- Fluid Hydraulics
- Hole stability
- Equipment Handling

The evaluation of both TTD methods are based on these criteria.

3.1 Torque and Drag

Which method has the best ability to reach the target depth based on their ability to handle torque and drag? CTD does not rotate and therefore does not achieve dynamic sliding that is achieved in rotary drilling. The friction from coiled tubing is static and puts a lot of strain on the equipment when tripping in and out of hole in highly deviated wells. The increased tension and increased chance for helical buckling will put a limit on the drilling distance as it is determined partly by the tensional strength and buckling limit when tripping. The force used to overcome the static friction will also limit how much force is transferred to the bit. Rotary drilling will always have the advantage of lower drag and better weight transfer to the bit in highly deviated wells.

The issue of a low buckling limit and weight transfer can be overcome by using a very low Dogleg Severity (DLS) when drilling deviated wells using coiled tubing. In the Kauparuk field, to reach laterals, as of June 2013, up to 4923 ft horizontal lateral length to a measured depth of 13375 ft; coiled tubing, a “push the bit” BHA and an average of 4 degrees/100 ft DLS were used (Burke et al., 2014). Low DLS and smooth trajectories helps with weight transfer, liner running operations and prove to be less problematic with respect to well bore conditions. To achieve this, the engineers at Kauparuk used specially designed software to effectively simulate the effect of the cumulative dogleg and pipe friction on the effective weight transfer. These simulations will reveal early on if the defined target is reachable or not. Simulations like this can be applied to the UmbiliDrill concept as well and compared to conventional methods. The drilling plan can be optimized to reach the target by lowering the cumulative dogleg, adding friction reducing lubricants/beads and/or utilizing extended reach tools, such as down hole vibration tools.

Reactive torque in the CT from the motor can make it difficult for the directional control of the tool face in the BHA steering system. This will also limit the hole size in CTD. Larger holes re-

quire larger and heavier drilling assemblies that require more force to be pushed along deviated well bores. The increased force will increase the chance of buckling and eventual lock-up where no force is applied on the bit.

Hole size, reactive torque and larger drilling assemblies will not limit TTRD in the same way as CTD. TTRD has better weight transfer and there are many rotary steerable systems available to accurately control the drilling direction.

However, it is possible for a CTD system to have signal lines built in that are able to continuously send telemetry data to surface for very precise directional control. TTRD relies on mud pulse surveys sent every now and then to check its telemetry. The same argument can be made for Logging While Drilling (LWD). These abilities are important as they help determine the smoothness and tortuosity of the well path, which in turn has a great effect on the total torque and drag experienced by the drill string.

In conclusion, with respect to torque and drag, rotary drilling has an advantage due to its strength and superior ability to transfer weight to bit in highly deviated wells.

3.2 Fluid hydraulics

Fluid hydraulics determines the ability of the drilling method to achieve the needed annular fluid velocity to successfully transport cuttings to surface. Cuttings transport requires a certain fluid velocity and certain fluid properties. To achieve the needed annular fluid velocity a certain pump rate is needed. This will increase the pressure inside the drill string. A smaller diameter will have a higher pressure loss than a large diameter to achieve the same fluid velocity. Therefore when drilling, both the annular volume and drill string volume is very important. Coiled tubing has a small inner volume and a relatively large annular volume and is immediately at a disadvantage to TTRD. TTRD has a large inner volume compared to its annular volume. The pressure build up in the coiled tubing to achieve the needed annular fluid velocity will limit its total drilling distance and its ability to reach Target Depth (TD).

In TTRD annular volumes are smaller compared to CTD and even smaller than annular volumes in conventional drilling. In addition the string is rotated. Hole cleaning is therefore not an issue, usually. These properties are beneficial in horizontal departures, as cuttings will take longer to settle.

Cuttings transportation in horizontal departures is another issue that reduces the cuttings transport ability of CTD. Cuttings deposited in highly deviated wellbores above the BHA, can only be removed through rotation or short tripping. Short tripping, being the only available option for CTD, will induce cyclic tension in the steel and will eventually cause fatigue. This has to be carefully monitored.

3.3 Hole Stability

Hole stability is related to lost circulation, formation damage, fluid influx and differential sticking. TTD operations in mature reservoirs will suffer from hole stability issues. Underbalanced drilling can be used to limit this issue beyond reservoir pressure management. CTD has an advantage in Underbalanced Drilling (UBD) operations by being able to maintain flow of produced fluids and to pump continuously during tripping in and out of hole. Therefore there is no chance of fluid loss and damaging the formation. Underbalanced conditions also increase the WOB. These underbalanced operations require fully contained well pressure. This means that a mechanical barrier including a lubricator and upper stripper of the hydraulic pack off in the well control stack is part of the primary barrier. In a properly designed operation, this gives the advantage of minimizing the threat to personnel and equipment during a kick when compared to conventional drilling that only uses the drilling fluid as primary barrier. (Society of Petroleum Engineers, 2014)

In sensitive reservoirs pressure fluctuations is not desired. Pressure fluctuations can be caused by surge and swab. Surge and swab effects in CTD are very small due to its relative size to the open hole. This allows for quicker trip times make CTD applicable even in places where UBD

and managed pressure is not possible due to weak formations. The cost saved from quicker trip times can make CTD more cost effective both from a cost-per-well and cost-per-barrel point of view. (Society of Petroleum Engineers, 2014)

However, for TTRD annular clearances are very small. Surge and swab effects must therefore be carefully monitored to not fracture or collapse the well bore. RPM and pump rate must be manipulated to account for these effects when tripping. A down hole pressure gauge (DHPG) is recommended to be used to monitor the pressure fluctuations (Andersen, 2015a). Surge effects can easily create a kick scenario and the kick detection is already difficult in a TTD operation as mentioned in 4.9. These effects also increases the time spent tripping.

The risk of differential sticking is much higher for CTD than TTRD. The lack of connections on a CT and therefore standoff between the well bore wall and most of the string, increases the surface area in contact with the bore hole wall which increases the risk of differential sticking during overbalanced operations. This is one of the major concerns when planning a CTD operation Andersen (2015b)

3.4 Equipment handling

The equipment handling in a TTD operation includes lifting operations, pipe handling and damaging the upper completion. TTRD can use the equipment already in place on most drilling rigs. It requires no special lifting operations. Whereas CTD will require modifications to the rig if not a specialized rig is used. The basic coiled tubing equipment is:

- Reel
- Component controls
- Injector with guide arch
- Well control components

This equipment needs to be lifted onto the rig and a large amount of space is required. If the cranes cannot lift the heaviest equipment or if the space requirements are not met it is not possible to perform CTD operations. This is where TTRD has a major advantage.

The most common TTD well is drilled through a 7" monobore completion with a $5\frac{3}{4}$ " to $5\frac{7}{8}$ " open hole diameter. This allows for the same size of pipes and BHA equipment that is already present or readily available on the rig (Andersen, 2015a).

With regards to pipe handling, during a coiled tubing operation the pipe is plastically yielded three times when running in hole and three times when pulling out of hole:

- From coil to guide arch
- Across the guide arch
- From guide arch into hole

The plastic yielding will weaken the pipe as is the nature of repeatedly deforming steel and the coiled tubing can only be used a finite number of times before being scrapped. A standard drill pipe can be maintained and pipes and connections can be replaced which is more cost effective than scrapping an entire coil of pipe.

The following arguments are inspired by Andersen (2015a), Andersen (2015b) and Klaussen and Borlaug (2009).

Drill strings used in TTRD are less rigid than normal drill strings. This means that the equipment is more easily damaged and can create abrasive edges on pipes when torquing using a tong. Abrasive edges are not desirable when it comes to damaging the in place completion.

Protecting the completion is one of the top priorities in TTD operations. The risk of damaging the completion and Christmas Tree (XMT) is mainly related to the size of the drilling assembly and rotation. In any TTD operation it is required to check the inner diameters of the in place completion. This is called drifting. This is done to ensure that the size of the drilling can safely pass through the completion without damaging any essential components. The assembly will

have a greater chance to get stuck and damage fragile down hole equipment such as the safety valve, especially if drilling equipment with abrasive angles is used. Rotation and especially rotation while stationary is a major cause of wear to the completion. Wear to the completion will lower its structural integrity. This means lower lifetime as well as lower burst and collapse strength.

Rig and riser centralization is important for both TTD categories, but extra important for TTRD due to its size and rotation. If the rig is not centralized any equipment run into the hole can come in contact with down hole equipment and even rest against them with some degree of force. Rotating a string in this state will cause extra wear on any equipment it is in contact with.

Wear sleeves used to protect the down hole safety valve is important for both TTD categories. The wear sleeve is a specially designed pipe that is installed in the completion across the down hole safety valve to absorb any damage caused by the TTD operation. For TTRD a special wear sleeve deployment and retrieval tool is run as part of the drill string and will install the wear sleeve at the desired depth. Wear sleeves are fragile and have a maximum set down weight. This brings us back to the importance of drifting and use of non-abrasive angles in the drilling assembly. Deforming the wear sleeve can make it difficult to remove and there is higher chance of damaging the down hole safety valve when removing the wear sleeve. A damaged down hole safety valve can result in replacement of the entire completion.

Chapter 4

Planning a through tubing drilling operation

Determining the decisions and steps that are involved in designing a TTD operation is important to understand how UmbiliDrill can be feasible as a method to successfully accomplish the same goals as TTRD and CTD. It will also be easier to understand which aspects of operation that UmbiliDrill has the potential to improve upon.

According to Nas and Laird (2001) there are a number of essential steps for a successful design of a through tubing drilling operation both for CTD and TTRD. These steps will be explained below and supported by Statoil experiences as well as case histories where data is available.

4.1 Establishing a cost overview

The first step is establishing the cost. That is, the economical impact of completing a TTD operation on the well and reservoir in question. The economical impact is decided by factors such as:

- Effect of water shut off
- Effect of production shut off for candidate well
- Total recoverable reserves
- Daily anticipated production

The cost of the operation has to be lower than the total revenue gained from increasing the recoverable reserves. The potential for a failed operation also has to be taken into account. Establishing a guarantee for increased revenue due to a successful operation will focus the value of a TTD operation rather than the overall drilling costs. Nas and Laird (2001) confirms that many mature assets on the NCS have seen significant increase in production from bypassed oil reserves. The relative number of successful operations compared to unsuccessful operations can also have an effect on the go ahead from the company's top management. Failures are often quoted and used as reasons not to take the risk of jeopardizing a well by drilling a new lateral. This is an extremely important point if UmbiliDrill should be considered for a TTD operation. Proper development, rigorous testing and assessment is needed to build confidence in a new concept.

4.2 Establishing objectives

The next step should be to establish a well profile, target and objectives. Deciding the objectives, such as drilling and producing bypassed reserves or drilling a lateral into an existing asset, will decide the type of sidetracks. The needed production rate for a financially productive well also needs to be established to determine the hole size. The required hole size for a financially viable production rate will determine if the production tubing in the motherbore is large enough and hence the feasibility of the entire TTD operation. The reservoir target will affect the well profile and is in a way the main objective of the TTD operation. The reservoir target must be clearly defined to include length, inclination, azimuth and size. Since these operations take place in mature fields establishing the target and objectives must be based upon the experience and knowledge attained from previous operations. Reservoir characteristics listed below must also

be established at this stage in the planning process.

- Reservoir pressure
- Fluids Oil/water
- Gasses CO₂/H₂S
- Gas Oil Ratio (GOR)
- Contacts Oil Water Contact (OWC)/Oil Gas Contact (OGC)
- Porosity
- Permeability
- Production Index
- Expected Drawdown
- Expected Production
- Geology
- Fractures

4.3 Candidate well selection

The mature fields on NCS often have a high number of available production wells. A selection process based on the well itself and the operability of the existing well as well as the drillability of the proposed sidetrack. The most optimal and closest candidates are then screened on the technical ability to sidetrack which addresses the issues:

- Through bore access
- Well cleanliness
- Kick off depth
- Interface complexity
- Sidetrack preparation
- Miscellaneous
 - Chrome tubing

- Plastic tubing
- Kick Off Point (KOP) vertical
- Tubing leaks
- Perforations above KOP
- Closed in Tubing Head Pressure (CITHP)
- Reservoir temperature
- Crane capacity

4.4 Finalizing well trajectory

Once a target and the candidate well have been selected the well profile and trajectory must be finalized. The trajectory must be designed to avoid problem zones due to formations, pressures or faults. Not planning for or properly identifying and avoiding problem zones may result in the failure and abandonment of the entire lateral. Torque and drag needs to be taken into account when designing the trajectory. There is little point in having a well path that that causes high frictional forces and results in lock-up of the string.

4.5 Pressure management and hole stability

Hole stability is an issue in mature reservoirs. Therefore, the following case history is important to understand the kinds of conditions that UmbiliDrill can be exposed to. The sand stone reservoir can be layered or intertwined with shale. When the sand stone is produced and depleted the pressure in the shale will remain relatively the same. Dealing with different collapse and fracturing pressures for shale and sand stone is a major challenge when conducting TTD in mature reservoirs. The Kauparuk field in Alaska has employed CT TTD to drill thin sands with intra-bedded shales with success (Burke et al., 2014). They overcame this challenge with efficient planning, proper reservoir management, drill fluid optimization and Equivalent Circulating Density (ECD) management. Based on regional stresses a mud envelope was developed

to effectively find a mud weight that helps ensure well bore stability. The stability of shale is also affected by cycling of BHP caused by annular friction pressure of the circulating mudsystem. Managed Pressure Drilling (MPD) was implemented to limit these cycles by carefully manipulating the choke. Due to its maturity and vast knowledge of pressures and the effect of manipulating the flow and pressures of producers and injectors in the reservoir very effective reservoir management is possible. The Kauparuk field is highly faulted and under an active water flood. Under these conditions high pressure differentials can form between fault blocks. A formation pressure management plan can be put into place and even out the pressures across the faults to some degree. The thin sand stone reservoirs at Kauparuk have a very small drilling window and due to the long laterals and high annular friction relatively high ECDs is expected at the bit. By adjusting drilling mud properties, flow rates and open hole size they were able to keep the ECD within the optimal drilling window.

4.6 Planning for completion

A plan for completion equipment and method is then based on reservoir characteristics, well trajectory, existing completion in the motherbore, hole stability and production profile. Special design modification of certain completion equipment may have to be planned for due to hole sizes and restrictions in the original completion. Some parts of the original completion may even have to be removed.

4.7 Choosing drilling method

The drilling planned up to this stage must be reviewed and a drilling method must be chosen. The drilling method and the following factors will indicate if it is possible to reach the defined reservoir target from the selected candidate well according to Nas and Laird (2001).

- Open hole length

- Maximum pull at TD
- Annular velocity
- Anti Collision
- Dog leg severity
- Fracure gradient
- Overbalanced pressure
- Maximum WOB at TD
- Circulation pressure
- Formation problems
- Completion complexity

4.8 Underbalanced drilling

The use of underbalanced drilling is decided based on these reasons

1. Pressure related drilling problems

- Fluid Losses
- Slop WOB
- Differentially stuck pipe
- Depleted reservoir

2. Reservoir improvement

- High skin factor
- Low permeability wells

If underbalanced drilling is selected special planning is required to ensure that the completion equipment in place and that the reservoir pressure and hole stability are able to handle such an operation. Underbalanced operations also require special equipment on the surface or the modification of existing equipment for gas and fluid separation.

4.9 Well control

Lastly, well control issues must be addressed. In TTD operations, regardless of drilling method, it is very difficult to detect kicks due to the small annular volumes. Clearances can be less than 0.0056 bbls/ft with typical open hole volumes of 10 bbls. Standard methods of detecting kick with sensitivities of +/- 6bbls are not optimal. A potential kick is a minor issue as the original completion and XMT are in place and that horizontal laterals do not accommodate for very much vertical displacement of a kick. This is especially true in underbalanced operations. Even so, being on the safe side is always better and the following methods should be in place for more accurate kick detection:

- Reducing the active system
- Installation of differential flow meter system
- Installation of an advanced kick detection system

Chapter 5

UmbiliDrill

5.1 System Description

UmbiliDrill is a concept for a new drilling method proposed by Aarbakke Innovation and Henning Hansen. The drilling system is an all-electrical drilling machine operated by a spool-able multi-course flexible umbilical deployed from the surface. The drilling machine is capable of gravity independent drilling by using a type of tractor that functions as a hydraulic drill collar (HDC)to move the machine in and out of the wellbore. Drilling is done by using a conventional drill bit powered by an electrical motor with directional control. The key unique and distinctive features in this system are listed below and can be seen in fig. 5.1:

- The drilling motor
- Directional control system
- The tractor functioning as a hydraulic drill collar
- The umbilical
- The sensors unit

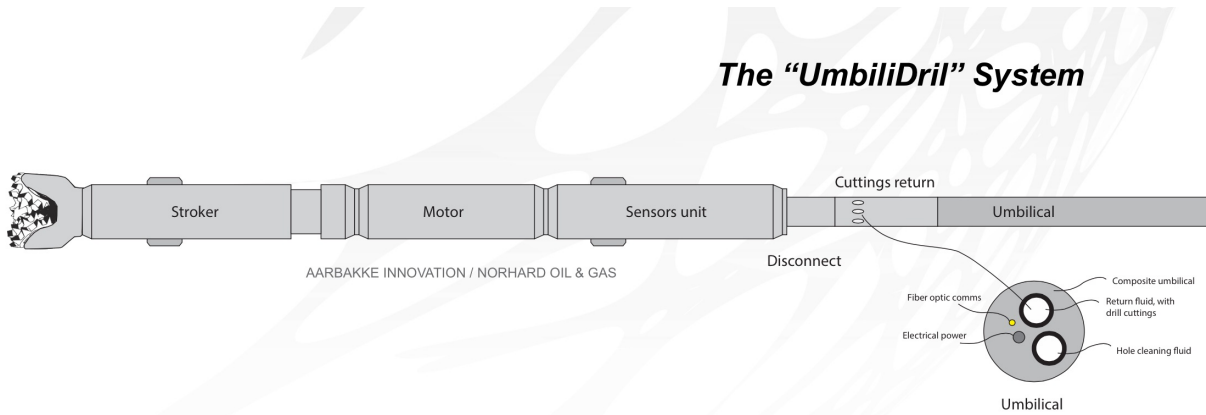

Figure 5.1: UmbiliDrill system schematic

5.1.1 The drilling motor

The drilling motor in this system is similar to conventional mud motors used in coiled tubing drilling in the way that only the bit is rotated. The difference in UmbiliDrill is that it the motor is powered electrically and not powered hydraulically with circulation of the drill fluid. This requires a motor that can supply the torque and bit rotation needed for an optimal drilling operation. A permanent magnet motor is a small, efficient and light weight electrically driven motor that is the best candidate for this drilling machine. An electrical system will give greater control over bit Rotation Per Minute (RPM) and torque independent from mud flow used to power conventional drilling motors. Several of these permanent magnet motors can be placed through out the drilling machine to power the hydraulics in the hydraulic drill collar.

5.1.2 Directional control system

The philosophy behind the design of UmbiliDrill is to utilize existing proven technologies in the drilling machine where possible. For the directional control system there is no need to reinvent the wheel. There are several available directional control systems used in CTD and other systems similar to UmbiliDrill. A rotary steerable system can be located in front of the motor and rotated along with the bit. Rotary steerable systems have been reliably used in the industry for many years. Modifications may have to be made to ensure its reliability when using a hydraulic

drill collar to move the drilling machine forwards.

5.1.3 The hydraulic drill collar

In conventional drilling the BHA with drill collars and gravity are used to transfer weight to the bit. The weight needs to be continuously monitored at surface to ensure that the string is in tension while keeping enough weight on the bit. A hydraulic drill collar is a tractor system that replaces conventional drill collars to supply axial force and displace the bit independent of gravity and absorb the reactive forces caused by the motor and bit. The idea in UmbiliDrill is to use this type system to eliminate the need for jointed pipe and give it the ability to drill highly deviated departures without the risk of buckling.

There are a few different designs for hydraulic drill collars that have been attempted and even some available and in use today. The specific design for UmbiliDrill is not yet decided, but the principle for hydraulic drill collars is the same. There are at least two anchors. The rear anchor is deployed and secured against the well bore wall. While the rear anchor is secured the front anchor is displaced in the forward direction. At maximum displacement the front anchor is deployed and secured. The rear anchor can now be released and be pulled towards the front anchor. Repeating this process will make the drilling machine crawl forwards. Axial tension and rotational torsion is absorbed in the friction between the anchors and the borehole wall. This principal mechanism can be observed in fig. 6.9

5.1.4 The umbilical

A cross section of the proposed umbilical is shown in fig. 5.1. The umbilical consists of two flow lines for any fluid supply and return. In addition to these flow lines there is an electrical line and a fiber optic line. These lines are bundled and encased in a specially designed composite material. The encasing composite material can be designed to have a high axial tensile capacity whereas the flow lines can be designed to have high burst pressure capacity. The composite

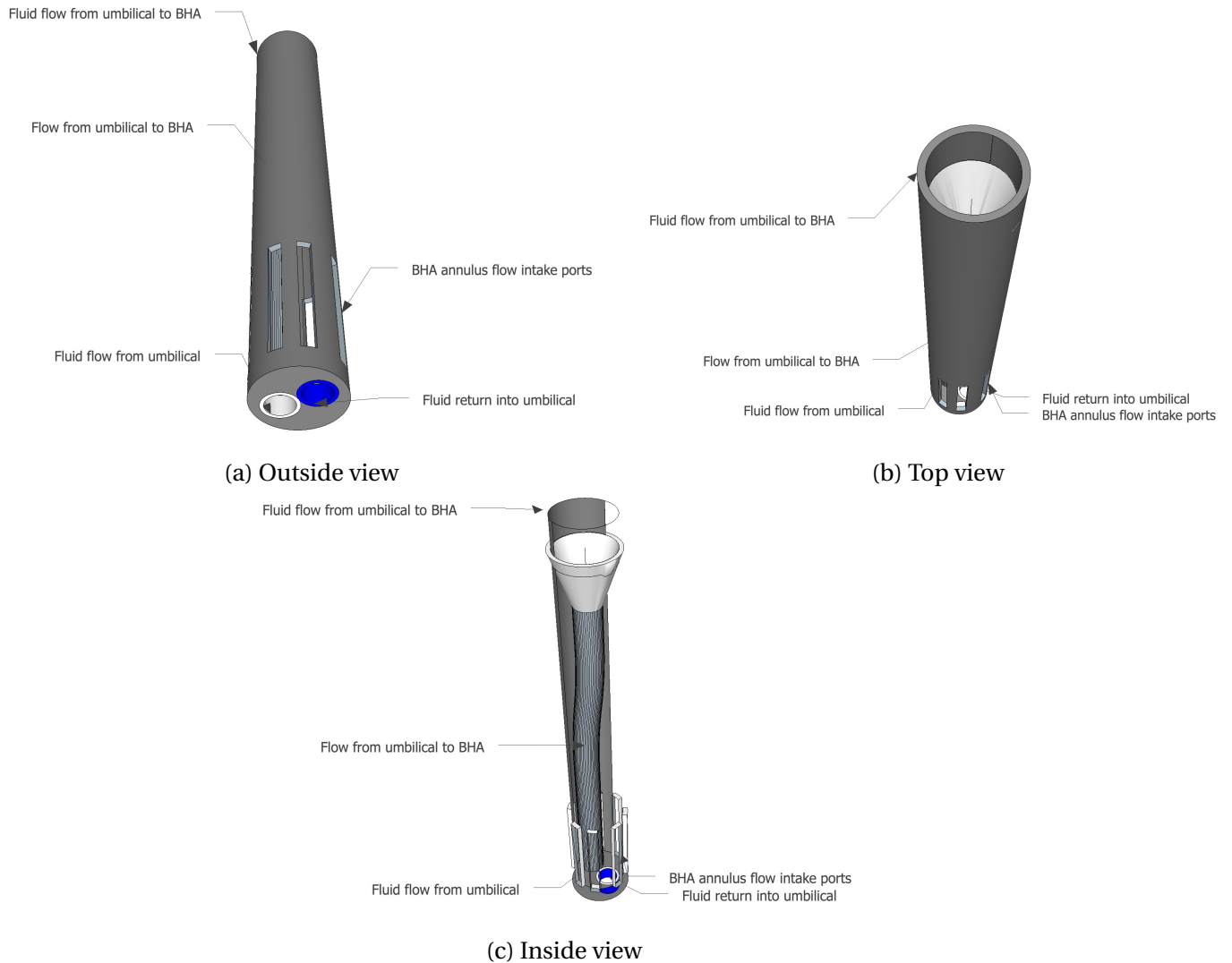

Figure 5.2: Design proposal for the crossover and intake port between the umbilical and BHA

material can also be designed to have a high buoyancy factor in the drilling fluid thus lowering effective weight and drag. The umbilical allows for a closed circulating system where mud supply and cuttings return is done in separate lines inside the umbilical. There is a special intake port with a float valve system that can direct flow into and out of any of the flow lines as well as directing flow through the annulus. The annulus will be filled from the top with a static mud designed to keep the open hole stable. A design proposal for the crossover and intake port between the umbilical and BHA can be seen in figure 5.2.

5.1.5 Sensors unit

The sensors unit in UmbiliDrill will be dependent on the operation in which it is used. Service companies with experience and established technologies will provide the needed equipment for a sensors unit. The main challenge is finding equipment with the correct dimensions. However, UmbiliDrill will be designed to take advantage of as much of the established technology as possible.

5.2 The potential of UmbiliDrill

The potential of UmbiliDrill is based on an evaluation of section 4.7 and chapter 3.

5.2.1 Torque and drag

With successful use of a hydraulic drill collar torque and drag will be transferred to the anchors and the contact points between the anchors and the well bore wall. By actively controlling the crawl speed of UmbiliDrill and the un-spooling of the umbilical, drag and the risk of buckling is essentially eliminated. When pulling out of hole the umbilical is spooled back onto its coil creating drag through the contact friction between UmbiliDrill and the well bore wall. To solve this the UmbiliDrill system will be designed to be able to crawl in both directions which will help eliminate the drag. The friction will still be there, but there will be less strain on the equipment due to both the hydraulic drill collar and the spooling at the top will contribute to the movement. Monitoring the relationship between these two points of movement will allow the system to keep the umbilical within the acceptable tensional limit. When running in hole the hydraulic drill collar will allow for drilling and movement in highly deviated departures. The main challenge here is to ensure that the anchoring points in the hydraulic drill collar can handle the forces required for drilling and tripping. This is related both to grip strength and formation strength. Different hydraulic drill collar technologies and methods are reviewed in the next

chapter to address this challenge.

Designing an umbilical with a lower material density will lower its buoyancy factor in mud. This will reduce its effective weight and therefore the contact force against the well bore wall. Less potential drag can allow for cheaper and weaker umbilical material for short departures and stronger, but more expensive umbilicals for extended reach wells. TTRD and CTD material properties cannot be designed to fit operational requirements to the same degree.

The maximum DLS for UmbiliDrill will be based upon the hydraulic drill collar's ability to function in curved well bores. This is based on the BHA length and the number of available gripping mechanisms along the BHA. The umbilical can handle a very high DLS compared to jointed pipe. The DLS capability is assumed the same as coiled tubing. However it will not suffer the same weight transfer issues as coiled tubing.

Another advantage is high speed data transmission through tube fiber optic line. Accurate and constant live updates of pressure, temperature, WOB and telemetry will allow for precise directional control, higher Rate of Penetration (ROP) and longer bit life. Challenges here will be to have a contingency plan if the fiber optics should fail. Having the same mud pulse data transmission as conventional rotary drilling can be an adequate contingency.

The inventor, Henning Hansen, also describes that the fiber optic lines incorporated into the UmbiliDrill umbilical can perform so-called distributed sensing. Measurements such as strain and compression on the umbilical can be real time measured every meter along the entire string. This will enable a highly monitored string, where torque and drag is continuously monitored. Thereby, increased drilling and tripping load control is substantially increased. It can be envisaged that "smart" pushing/pulling control downhole and at surface, combined with the real-time distributed sensing will introduce manipulations to minimize high load wellbore wall contact and contact with the in place completion. See Appendix E for more information.

5.2.2 Fluid hydraulics

The umbilical allows for a closed circulating system. This means that mud supply is done through one of the flow lines while cuttings return is taken through the other line. There is no flow in the annulus. The small size of the inner flow lines creates an optimal environment for achieving turbulent conditions and the flow speed required for optimal cuttings transport. One issue is if circulation is stopped any cuttings in the flow line and in the BHA open hole annulus will settle. UmbiliDrill cannot be rotated or tripped shortly to stir the cuttings into the flow. One solution for cuttings beds in the BHA open hole interval is tripping backwards while rotating the bit. As for cuttings beds in the flow line, other technologies that use a closed circulating system must be consulted. However, constant circulation is the best preventable action.

When using very small volumes and diameters the total pressure loss will increase. The increased pressure will no longer fracture the formation, but rather the flow lines themselves. Bursting the flow lines will result in replacing the umbilical which can be very costly. Designing a material with high burst strength is essential if UmbiliDrill can be capable of long departures. This is not only an issue of bursting the umbilical, but this will affect the ECD and can have consequences for staying within the drilling window. An idea for UmbiliDrill is to have specially designed booster pumps in the BHA that can pump fluids in either direction to aid the pumps topside and relieve some pressure in the return flow. Mud return can also be routed in the annulus alone or partially, by selecting return pump speed and fully or partially open the intake fluid return ports above the BHA.

5.2.3 Hole stability

The drilling mud is only exposed to the formation the BHA interval, the mud properties can be designed for that specific formation. This will make it easier to stay within the drilling window, reduce formation damage and reduce the chance for influx. A pressure gauge with constant live updates through the fiber optic line will allow for accurate bottom hole pressure management.

A static fluid in the umbilical annulus will have higher density than the circulating mud to keep them from mixing at the fluid intake port. This static fluid will also have to be specially designed for the formations to ensure that it keeps the open hole from collapsing and from fracturing. The annular fluid can also be assisted by MPD to accurately control the pressures. This system will also help lower the risk for differential sticking.

Surge and swab effects needs to be monitored as usual. An MPD system can help relieve the surge and swab effects by increasing the choke pressure when Pulling Out of Hole (POOH) and relieving choke pressure when Run In Hole (RIH). However, there will be no harmful pressure fluctuations due to the lack of connection and the continuous circulation capability.

The increased hole stability gives UmbiliDrill the potential to drill much further with less frequent hole stability issues. A major limiting factor here is that the drilled formations are not uniformly strong. This means that the hydraulic drill collar can have an issue of breaking the formation and losing its grip. The hydraulic drill collar is dependent on a open hole that is as uniform as possible. If there is a cave in the grippers might not be able to reach the bore hole wall. A solution can be to have multiple hydraulic drill collars located along the BHA. If one cannot get a sufficient grip there is a backup available move the drilling machine outside of the collapsed area. The only limit here is the maximum allowable length of the BHA to pass through the milling window in the completion.

The same distributed sensing made capable of the fiber optics line can be used to monitor distributed temperature and acoustics, which can provide unique information about fluid circulation, gas flow, zonal inflow and zonal fluid loss. This data may be proactively used to test drilled through zones.

5.2.4 Equipment handling

UmbiliDrill will require much of the same equipment as CTD:

- Composite umbilical reel
- Composite umbilical injector with guide arch
- Hydraulic power pack
- Control unit
- Well control equipment

This will require modifications to rigs with limited space and the equipment will require heavy lifting. There can be, however, specialized vessels such as light weight intervention vessels capable of using UmbiliDrill.

When running in and out of hole the composite umbilical will experience the same bending and straightening as coiled tubing from the coil across the guide arch and into the hole. A composite string will not experience plastic yielding and will not suffer from fatigue in the same way as coiled tubing. The life time for UmbiliDrill will be significantly longer before having to replace the umbilical. Studies will have to be made when the composite design is established.

When it comes to damage to the in-place completing the smoothness of the umbilical is an advantage. There are no abrasive edges that can catch and damage down hole equipment. The production tubing will suffer less wear due to this with an added benefit of no rotation. The UmbiliDrill BHA is another issue. This BHA can have components that can be damaging to the down hole equipment. It is also not possible to slowly rotate the BHA to get past areas where there is a high potential for getting stuck, such as the milled window. Drifting the completion and ensuring a smooth BHA will be essential.

Rig centralization could be less of an issue with UmbiliDrill on floating rigs. This depends on the flexibility of the umbilical and if movement of the umbilical against the Blow Out Preventor (BOP) and XMT is not an issue. It may not have to be heavily compensated in the same way as TTRD and CTD due to its flexibility. The umbilical could be reeled out so that there is slack that allows for both horizontal and vertical movement. For fixed platform centralization to avoid contact between UmbiliDrill and the down hole equipment.

5.3 UmbiliDrill motivation

5.3.1 General

Establishing the advantages and disadvantages with the UmbiliDrill system is important towards the incentive of developing the system. If there aren't any clear advantages with the system, there would be no point in spending time, effort and money to develop UmbiliDrill. The potential described in this chapter does create some incentive.

There are three ways in which UmbiliDrill will gain an advantage over other methods. First the system will have to be able to drill a well with less risk of jeopardizing the operation with respect to HSE and cost. Secondly, the system must be able to drill the well more effectively from an economical perspective. Thirdly, the system will have an advantage if it is applicable to other areas than through tubing drilling operations.

5.3.2 HSE and cost

The first and main advantage of using UmbiliDrill in a through tubing drilling operation is that it will be more effective at preserving the in-place completion. Any damage to the tubing, tubing hanger, XMT or down hole safety valve can have disastrous consequences. UmbiliDrill preserves the tubing extending the lifetime of the completion. This reduces cost in the long run. A failed tubing can also have safety and environmental consequences. Leakage and pressure build-up in the tubing annulus increases the risk of spillage to the environment. Changing out the tubing is a complex operation in it self that carries its own set of risks to the safety of the personnel with it. Damaging the x-mas tree increases the risk of a blow out which is devastating both financially and to the safety. Damaging the down hole safety valve or the tubing hanger will have the same risks. Changing out any of this equipment is another financial and HSE burden.

A second advantage is the elimination of buckling, high strength to weight ratio and extreme fatigue limit of the umbilical. Eliminating buckling not only removes this phenomenon as a

limiting factor during planning, but reduces the risk of getting the string stuck. Equipment stuck down hole can lead to fishing operations that can be very costly and have their own set of risks to HSE. The high strength to weight and extreme fatigue limit of the umbilical gives the equipment a longer lifetime making it more cost effective. These properties also reduces the risk of the equipment failing during an operation leading to more fishing operations.

There are however some inherent risks of using UmbiliDrill. Currently these are identified as the heavy lifting required for installing the surface equipment and well integrity. Suspending the heavy reel above the rig is a financial and Health, Safety and Environment (HSE) risk.

Other areas of risk includes the pipe handling system. Designing an effective system that minimizes human contact during deployment of the BHA and other tubulars into the well will reduce HSE risks. A system that could do this remotely and automatically will be the most optimal solution, but will carry with it more development costs. Henning Hansen is also the original inventor of the Seabed Rig concept, which is a part of the Norwegian company Robotic Drilling Systems AS (Hansen, 2015). This company is about to commercialize robotic systems for handling BHA and similar tubulars (Robotic Drilling Systems AS). This can be an ideal system for handling the UmbiliDrill BHA.

5.3.3 Economic efficiency

Economic efficiency is in this section meant by how effectively the well can be drilled with respect to the optimal position and effective well path. A optimal position is the orientation and placement of the well in the reservoir that yields the highest production rate. An effective well path will reduce the tortuosity in the well which reduces the total completion length and complexity. The high degree of precise directional control of the UmbiliDrill system along with real time logging while drilling allows for optimal positioning of the well. The MPD and closed loop circulation will reduce fluid losses and damage to the reservoir. This has the effect of giving the well a greater lifetime and greater production rate with limited stimulation. This is very important as the first step in any drilling operation is to make sure the well can produce enough to

cover the cost of not only the reservoir development but the cost of shutting off the mother well to drill the new side track. If UmbiliDrill can accomplish this with a price tag that has a higher profit to investment ratio than conventional through tubing drilling methods, it will have the potential for commercial success.

5.3.4 Other areas of use

It is important to consider other areas of use where UmbiliDrill is applicable. By catering only the the market for through tubing drilling operations sets a limit on potential profits. Opening the technology up to markets such as cheaper exploration drilling, extended reach drilling or deep water drilling can be advantageous. UmbiliDrill has the potential to drill wells from smaller and less expensive rigs because it does not need high pressure risers. Today, in deep water drilling, it is also common to utilize a costly subsea located pumping system to circulate mud from the wellbore to the surface to reduce hydrostatic mud pressure in the wellbore. Using UmbiliDrill, a subsea pump system like this is not required (Hansen, 2015).

It also does not have to abide by the conventional strict rig centralization and riser tensioning demands which saves time, cost and effort. Quick tripping speeds, increased bit life and accurate pressure control saves time and cost spent on changing worn bits and reducing the number of casing sizes. These are all factors that can reduce cost and HSE risks in exploration drilling and deep water drilling. Extended reach drilling is achievable due to the lack of buckling limit and high strength to weight ratio of the umbilical. However, currently this is limited by the maximum length of umbilical that can be supported by a coil and limits in the fluid circulation system. These limits are discussed in sections 8.3.3 and 8.4.3 respectively.

Chapter 6

Technologies that support the UmbiliDrill concept

The potential of UmbiliDrill discussed in section 5.2 are based on imagining the behavior of UmbiliDrill in a drilling scenario and are therefore only preliminary. However, by reviewing technologies that serve as evidence for the claims made for the potential of UmbiliDrill. There are technologies that individually can be used as a component in the UmbiliDrill system. These individual technologies that can function as the UmbiliDrill components can be put together to make up the entire system. For instance, there are numerous companies that designs bits and directional control systems and have a high success rate. There are also companies that make tractors that can function as a hydraulic drill collar. It is important to review the technologies that are available or under development that fits in as one or more UmbiliDrill building blocks to give an indication towards the feasibility of the system.

The most important components of UmbiliDrill that are available in other technologies are the following:

- The hydraulic drill collar
- The composite material for the umbilical

- The fluid circulation system
- The permanent magnet motor

6.1 The Kolibomac concept

Kolibomac is an abbreviation for Continuously Lining and Boring Machine. It was a concept for gravitationally independent drilling created by prof. Arild Rødland in 1981. As the name indicates, Kolibomac was intended to continuously case the open hole while drilling. A hydraulic drill collar system would supply the weight on bit. This was one of the first attempts at developing this sort of drilling machine. There was a series of doctoral theses dedicated to the development of this technology (Moen, 1995; Pourjavad, 1993).

The vision behind Kolibomac was to find a way to drill a well without relying on a rotating drill string and being able to drill and case the hole in a single run. The UmbiliDrill-system shares the first part of Kolibomac's vision and includes many of the same important components as UmbiliDrill. The most important aspect about Kolibomac gives an indication towards the feasibility of being able to drill using a hydraulic drill collar. Particularly a hydraulic drill collar system that uses armed rubber packers. The possibilities and potential that the designers envisioned in this type of drilling is also an important aspect to consider.

The developers of Kolibomac envisioned many of the same benefits with respect to a hydraulic drill collar and an umbilical with closed loop mud system as what can be seen in UmbiliDrill. The drilling fluid is only in contact with the formation where the drilling happens. The drill fluid can therefore be designed for optimal drilling without taking hole stability or pressures into account. As with UmbiliDrill, Kolibomac was capable of high data transfer rates. The detection capabilities would allow, for instance, for very early kick detection. Float valves inside the umbilical and packers on the outside that could be activated by electrical signals was also imagined as an added safety feature.

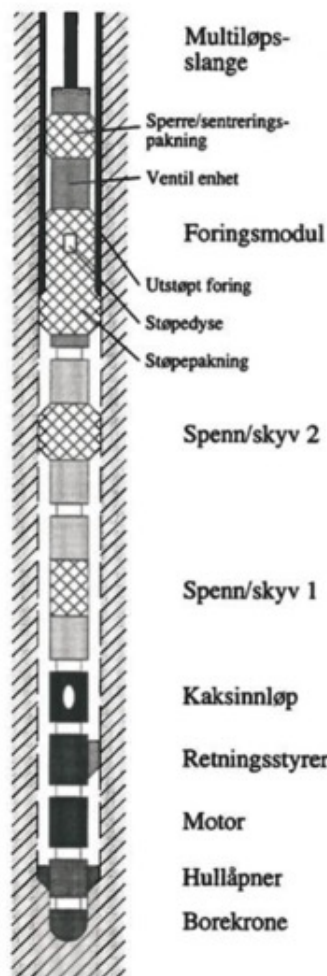

Figure 6.1: Kolibomac system schematic (Moen, 1995)

6.1.1 System Description

A motor is located directly behind the bit and reamer. The torque generated by the motor and bit is transferred to a hydraulic drill collar. This anchoring system also generates weight on bit. Hence, there is no longer need for a drill pipe connected to a top drive at surface to do the same job. The hydraulic drill collar anchor will serve as a fixed point in the well directly after the bit. By using a steerable system it is possible to have full control of the well trajectory. Thus, all of the necessary components that are needed in traditional drilling are in place for this system without the need for drill pipe and drill collars.

The next key element is the casing module. This replaces traditional casing programs by contin-

uously cementing the hole concentrically to the drilling machine leaving a continuous casing in place consisting of a type of cementing mass. This can solve the usual hole stability problems like fracturing or collapse of the formation. The risk of lost circulation or gas influx is therefore eliminated. The drilling fluid can be tailored specifically to the formation that is drilled at the time. This has the potential to simultaneously give maximum rate of penetration while having optimal cuttings transport.

When a hole is continuously cased problems related to differential sticking will be eliminated. The drillpipe can therefore be replaced by an umbilical that can supply drilling fluids, electricity, casing material and signals. The possibilities for measurements while drilling such as directional data, position and formation data is almost limitless. The developers of Kolibomac also saw the benefits of having a dual flow line umbilical with mud supply and return.

The Kolibomac system utilizes a conventional drill bit that is driven by a hydraulic axial piston engine. This is a compact engine that can supply significant torque, but it can easily be replaced by a conventional mud motor. For UmbiliDrill these motors are outdated. Today there are permanent magnet motors powered by electricity available that can be used in the same manner. The deciding factor is the ability to have data transfer to the reamer as this is the component that drills the hole to be cased.

The hydraulic drill collar system used on Kolibomac was a new drilling mechanism and is one of the most important and distinguishing features of Kolibomac. In conjunction the Kolibomac-project there were a number of different designs for the tractor system. The first prototype was built in 1985 and was to be used as part of conventional drilling to supply extra weight to the bit. Another design was built for the tunnel drilling industry with a diameter of 1,2 m. A third design, which is the design most similar to the stroker in Kolibomac was built in 1988. A 300 m vertical hole was successfully drilled using this design.

The main principal for the hydraulic drill collar is that a packer fastened to a cylinder is set hydraulically and the machine is pushed forward much like a piston. There is a specially designed spline connection between the piston and the packer cylinder so torque can be absorbed. For

the drilling machine to be able to crawl forwards there has to be two identical packers at either end of the stoker. When the rear packer is inflated and the machine is secured against the bore hole wall, pressure is set on the rear cylinder pushing the machine forward. The front packer is set before deflating the rear packer. Pressure is set on the front cylinder pulling the rest of the machine behind itself. The process can be seen in figure 6.2.

When the rubber packers are inflated they will fill the entire openhole annulus. Therefore, if UmbiliDrill were to use the Kolibomac hydraulic drill collar for conveying the drilling assembly it would have to be located at the back with the circulation sub in front of it. Fluid can now be pumped through the string, out the bit, along the BHA and finally back into the drill string. This is assuming that the Kolibomac hydraulic drill collar can be fitted with a dual flow line like the one in the umbilical. A second circulation sub could be fitted at the rear of the hydraulic drill collar to divert fluid into the annulus if desired.

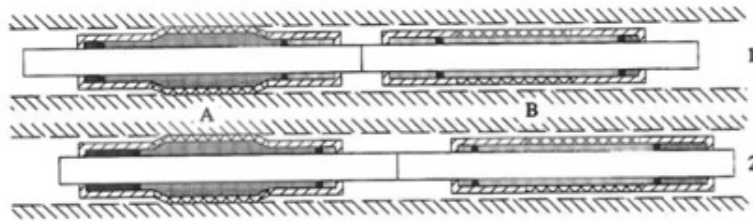

Figure 6.2: Kolibomac Hydraulic Drill Collar (Moen, 1995)

6.1.2 The inflatable packer, no-slip condition and tensile stress limits

The inflatable packer designed for Kolibomac needed to be both resistant to wear and be resistant against swelling in the hydraulic fluid used to inflate the packer. Two different types of rubbers were used in its construction reflecting the design criteria of Kolibomac. The inner layer is swelling resistant while the outer layer is extremely wear durable. Two layers of aramid cords were imbedded and wrapped concentrically and helically between the rubber layers.

The packer in the hydraulic drill collar will absorb the torque, axial load and fluid pressures on the inside and outside. The forces experienced by the packer will then be absorbed through the aramid fiber cords. At inflation the packer is secured against the bore hole wall and there should

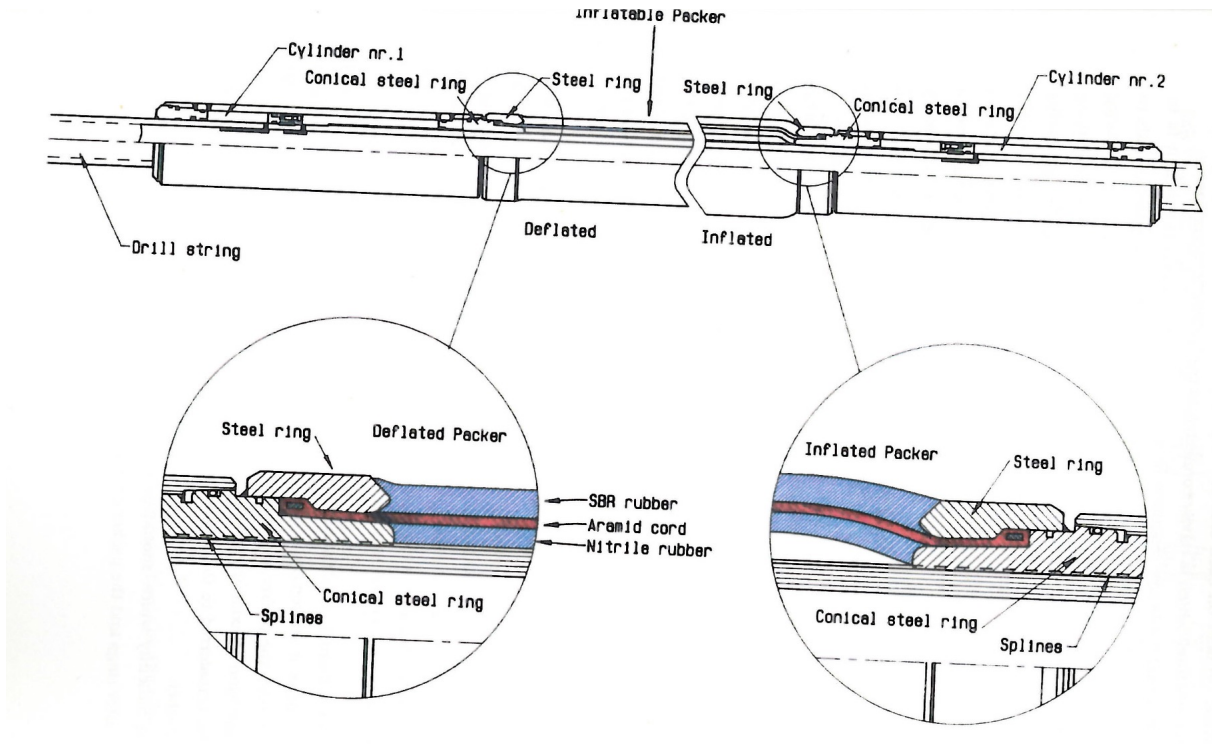

Figure 6.3: Hydraulic drill collar packer assembly used in Kolibomac (Pourjavad, 1993)

be no slippage when external loads are applied. This no slip condition is deduced by Pourjavad (1993) and shown below.

The vector summation of the friction between the packer and formation in both directions, axial and tangential should be higher than the vector summation of the axial and tangential load transfer from the drill bit and motor. If friction in the axial and hoop directions are defined as F_{fa} and F_{fh} , respectively, with external loads such as F_a and $M_t = F_t \cdot R$, the axial force by pushing action of the hydraulic drill collar and torsional moment from the motor respectively, then the external force F and friction force F_t illustrated in fig. 6.4 can be calculated as follows:

$$F = \sqrt{F_t^2 + F_a^2} \quad (6.1)$$

F_a and F_t are the forces between the drill collar and the bore hole wall.

$$F_f = F_N \sqrt{\mu_t^2 + \mu_a^2} \quad (6.2)$$

where

$$F_N = 2\pi R \times L_{eff} \times \Delta P$$

and

$$\Phi_1 = \tan^{-1} \left(\frac{F_t}{F_a} \right) \quad (6.3)$$

$$\Phi_2 = \tan^{-1} \left(\frac{\mu_t}{\mu_a} \right) \quad (6.4)$$

With regard to fig. 6.5, the requirement for no-slip condition between the packer and the bore hole wall is defined by eq. 6.5 or eq. 6.6

$$F_f \times \cos(\Phi_1 - \Phi_2) > \sqrt{F_t^2 + F_a^2} \quad (6.5)$$

$$2\pi R \times L_{eff} \times \Delta P \sqrt{\mu_t^2 + \mu_a^2} \times \cos \left(\tan^{-1} \left(\frac{F_t}{F_a} \right) - \tan^{-1} \left(\frac{\mu_t}{\mu_a} \right) \right) > \sqrt{F_t^2 + F_a^2} \quad (6.6)$$

ΔP = Packer internal and external hydraulic pressure difference ($\Delta P = P_i - P_e$)

R = Crown radius of the inflated packer (Kolibomac's inflated packer radius = $D/2 = 315/2$ mm)

L_{eff} = Effective length of the packer in contact with the borehole wall

μ_a, μ_t = Coefficients of friction in axial and hoop directions

In fig. 6.3 and during operation of the hydraulic drill collar, the packer of length L will behave the same as a rod in tension where the fixed point is at $L/2$ and the end where the axial force is applied is where the packer is fastened to the hydraulic cylinder. The packer ends are fastened to the drilling assembly with splines that absorb the torque generated by the motor and drill bit. This makes the packer the same as two rods of length $L/2$ where equal amount of torque is applied at the end with a common fixed point in the middle. This is shown in fig. 6.6 where M_t

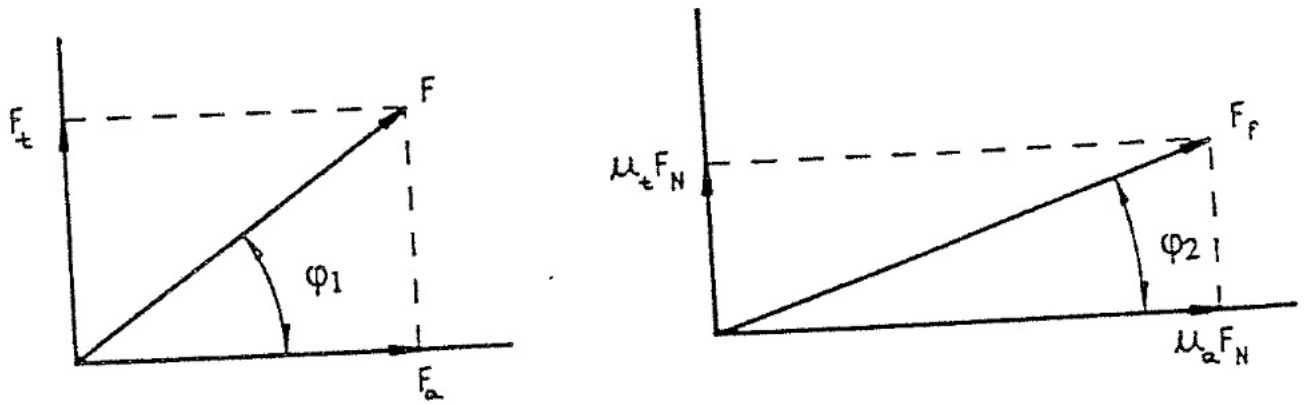

Figure 6.4: Vector illustration of the external friction forces (Pourjavad, 1993)

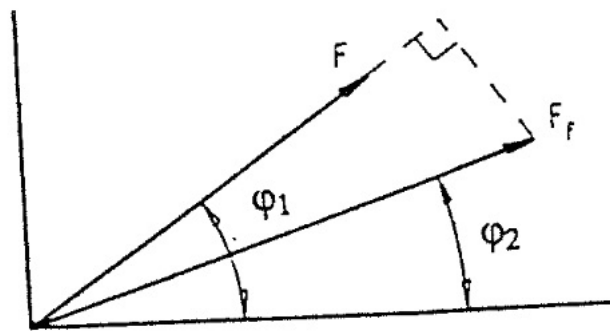

Figure 6.5: Vector illustration of the external friction forces on the same coordinate axes (Pourjavad, 1993)

is the torsional moment.

The resulting tensile stress of the cords in the packer while under axial force, torsional moment

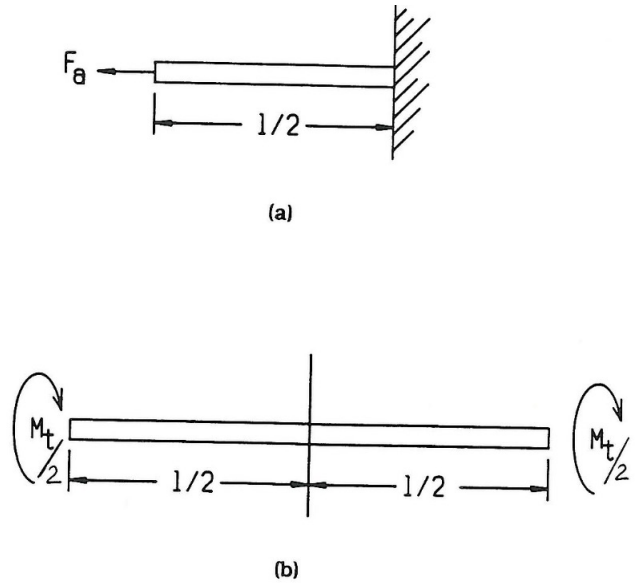

Figure 6.6: Inflatable packer presented analogous to a bar under axial load (a) and torsional moment (b) (Pourjavad, 1993)

and tensile stress due to the internal pressure of the packer is represented by σ_{1cord} , σ_{2cord} and σ_{3cord} respectively can be calculated using the following equations:

$$\sigma_{1cord} = \frac{F_a \cos \theta}{2nA_{cord}} \quad (6.7)$$

$$\sigma_{2cord} = \frac{M_t \sin \theta}{R_o n A_{cord}} \quad (6.8)$$

$$\sigma_{3cord} = \frac{\pi R_o^2 (1 - x^2) P}{2nA_{cord} \cos \theta} \quad (6.9)$$

The sum of these equation will be the resultant tensile stress of the cords.

$$\sigma_{cord} = \sigma_{1cord} + \sigma_{2cord} + \sigma_{3cord} \quad (6.10)$$

F_a = axial force

A_{cord} = cross-sectional area of the cord

n = number of cords

θ = cord angle

M_t = torsional moment

P = internal pressure of the packer (same as internal pressure needed for no-slip condition in eq. 6.6)

R_o = represented by r in fig. 6.7

$x = \frac{r_m}{R_o}$, where r_m is the mandrel radius seen in fig. 6.7

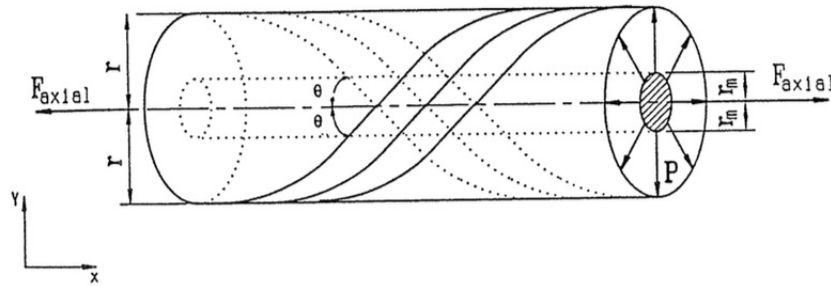

Figure 6.7: A fiber reinforced rubber packer under internal pressure and axial force) (Pourjavad, 1993)

The actual tensile stress of the cord will be higher than calculated by these equations. This is due to pre-compression and the special form of the packer ends. For the purposes of this thesis the results will be accurate enough to compare calculations with the yield strength of the reinforcing fibers to find the failure criteria. A more detailed derivation and explanation of the no-slip condition and tensile stress equations is given by Pourjavad (1993).

6.2 The Anaconda system

The description and discussion of Anaconda is based on Marker et al. (2000); Andersen (2015b); Hansen (2015).

The Anaconda system is a joint development from Halliburton and Statoil that began in 1997. The system is, similar to UmbiliDrill by using an all electrical gravitationally independent drilling and intervention machine operated by a spoolable Advanced Composite Coiled Tubing (ACCT).

The difference between them is the use of a closed circulation system in UmbiliDrill, the use of permanent magnet motors to drive hydraulic components and drill bit, and possibly the hydraulic drill collar design. The Anaconda project was born from the challenge to overcome the dependence of steel tubulars and the low bandwidth of conventional mud-pulse telemetry of transmitting down hole measurements. The developers of Anaconda had the vision of developing a system that could be remotely operated, have real-time monitoring capabilities, have a tractor driven BHA and have 3D steering. This could allow Anaconda to drill into previously inaccessible hydrocarbon pockets with less risk while being more cost effective from a cost per barrel point of view.

The system was tested by drilling casing filled with different cement types. The testing confirmed that the system could drill independent of gravity and could even mill a window off a whipstock. The system performed over 300 circulating and tripping hours, 100 drilling hours and 30 milling and reaming hours. The ACCT endured more than 50 times the number of stress cycles than are usually considered acceptable for a standard steel coiled tubing. After this a 1800 ft well was successfully drilled at Halliburton's Dincan Technology Center (Marker et al., 2000).

However, due to poor understanding of constructing composite tubing the project was never commercialized. The production process of layering the composite materials created micro-annuli where gas could gather. When the tubing was reeled to surface the gas would expand and destroy the ACCT (Andersen, 2015b). Because Anaconda and UmbiliDrill have very similar areas of use and vision, examining the Anaconda system and learning from the mistakes made can give more indication towards the feasibility of UmbiliDrill.

Henning Hansen is also the inventor of a spool-able composite rod and associated technologies which is today commercialized by the Norwegian company Ziebel AS. The composite material and construction will not suffer from the problems observed on the Anaconda umbilical, such as for example gas intrusion and explosive decompression. (Hansen, 2015)

6.2.1 System description

The Anaconda system has three main parts:

1. The surface equipment
2. The ACCT with embedded wires
3. The tractor driven BHA

The surface equipment

The surface equipment consists of a control cabin, tool cabin, injector, reel, tower, pipe-handling system, blowout preventers, a fluid system, and the digital control and data-acquisition system. These are all customized for Anaconda. A similar system as the one described in Marker et al. (2000) can be used for UmbiliDrill as well.

The ACCT with embedded wires

The ACCT for Anaconda was designed together with the company Fiberspar and had the same design criteria as the umbilical intended for UmbiliDrill. The ACCT for Anaconda, however, only has one fluid channel and has imbedded copper wires for signals and power. ACCT has a much higher strength to weight ration than steel tubing and low material density. This makes the tubing much more flexible allowing for more complex well paths and gives it a high tolerance for low-cycle fatigue. The low material density allowed the the ACCT to become neutrally buoyant in drilling fluids. The composite material is also resistant to corrosive fluids and gases encountered while drilling. These factors makes the ACCT ideal for long reach drilling without any risk of reaching the tensile yield limit due to drag. The specifications for the Anaconda ACCT can be seen in table 6.1.

Table 6.1: Anaconda ACCT data (Statoil, 2000)

OD/ID	78/51 mm	3.06/2.03 in
Internal working pressure	34.5 MPa	5000 psi
Burst pressure	87.6 MPa	12700 psi
Ultimate Tensile Capacity	185.5 kN	41700 lbf
Ultimate Collapse pressure	30 Mpa	4350 psi
Minimum Bend Radius	1.96 m	6.43 ft
Comparison with steel coiled tubing		
	CT	ACCT
Weight in air	5.05 lb/ft	3.11 lb/ft
Weight in 13.3 ppg drilling fluid	4.02 lb/ft	0.3 lb/ft
Drag in a 10000 ft horizontal hole	8699 lbs	625 lbs

The tractor driven BHA

The Anaconda hydraulic drill collar for gravitationally independent drilling is a design by Western Well Tools (WWT). This is a coiled tubing service company and have developed a specialized tractor to overcome the horizontal travel limit due to buckling of regular coiled tubing. The principle of propulsion is the same as Kolibomac, however it uses mechanical grippers that are extended into the bore hole wall instead of inflatable packers. It is operated by increasing fluid pressure to a predetermined set point where the tractors are activated. Fluid is diverted to either gripper using a special diverter located between the two grippers. If it is the front grippers turn to be activated fluid is directed to the front gripper until it is extended and secured. A piston is then activated pushing the bit forward and pulling the tubing behind it. This process is repeated for the other gripper. The tractor can be turned off by reducing the fluid pressure below the set point. To restart the tractor the pressure is reduced to zero before increasing it beyond the set point again. The walking mechanism is seen in fig. 6.9. This figure depicts inflatable packers, however this is wrong as WWT tractors use mechanical anchors. The different specifications for the WWT tractor models can be seen in table 6.2.

These tractors have proven commercial track records of being able to convey coiled tubing tool strings beyond the point of lock up and being able to perform tasks such as milling of bridge plugs beyond the point of lock up (WWT International Inc.). The point of lock up is the point where a coiled tubing without a tractor would lock up due to buckling.

Table 6.2: WWT Coiled Tubing Tractor specifications

Model	300	338	350	388	470
Collapsed OD (in)	3.00	3.38	3.50	3.88	4.70
Expanded OD (in)	5.2	4.2	7.4	5.1	8.5
Tractor ID (in)	0.5	0.75	0.5	0.75	0.8
Total length (ft)	22.6	22.6	23.9	22.6	27.5
Maximum output (lbf)	5150	6250	9200	6250	14500
Max. operating differential pressure (psi)	1500	1500	1700	1500	1700
Nominal speed (ft/hr)	750	1000	750	1000	1000
Fluid consumption at nominal speed (gpm)	6	7.3	7	7.3	15
Max. centerline flow (gpm)	120	120	120	120	120
Maximum overpull (lb)	54000	69000	60000	69000	69000
Maximum temperature (F)	300	300	300	300	300
Connection type	2 3/8 PAC	2 3/8 PAC	2 3/8 PAC	2 3/8 PAC	2 3/8 PAC

In the Anaconda BHA using the WWT tractor, there are two electronically operated circulation subs at either end of the tractor. The upper sub can divert fluid flow for better hole cleaning and divert other fluids that have the potential to plug the BHA. The lower sub will keep the necessary fluid pressure in the tractor and direct flow to the mud motor or the annulus. There are also two weight sensors at either end of the tractor. The upper sensor will accurately measure the tension in the ACCT and the lower sensor will accurately measure the WOB for optimal drilling conditions. These sensors will allow for accurate rate of feed of ACCT and walk speed for the tractor. According to Phillips et al. (2000), the tractor used in the Anaconda system could apply up to 13000 lb of force with a rate of penetration reaching 135 m/h. The walk speed could reach speeds of 213 m/h.

A dynamically operated bent housing is used for the 3D steering capabilities. It will bend the motor and drill bit in the desired direction with the desired DLS. It can also change the tool face direction while on bottom. This will result in very smooth well bores and high DLS capabilities resulting in drilling no longer being a limiting factor in well path design. The BHA design for Anaconda can be seen in fig. 6.8.

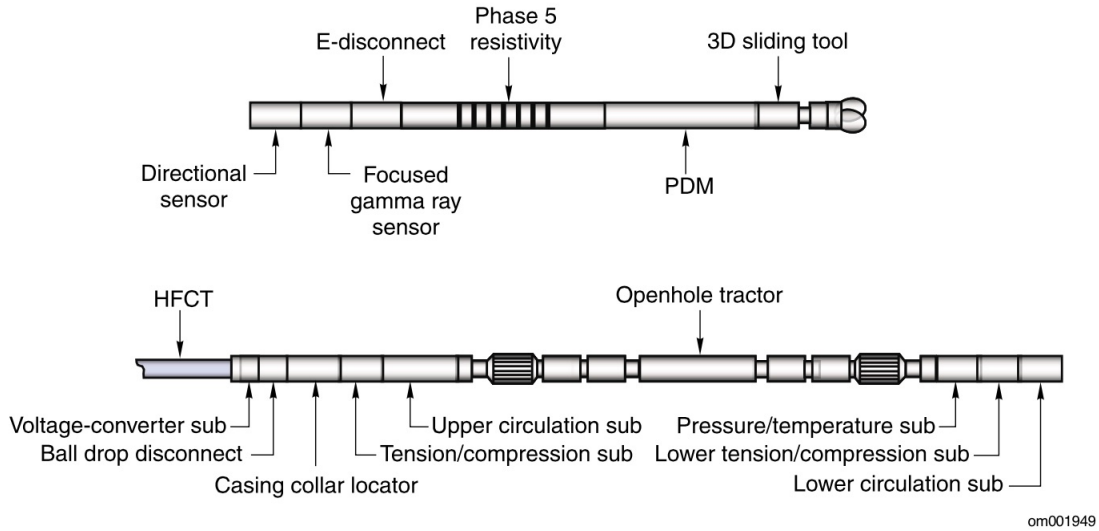

Figure 6.8: Anaconda system BHA subs. (Marker et al., 2000)

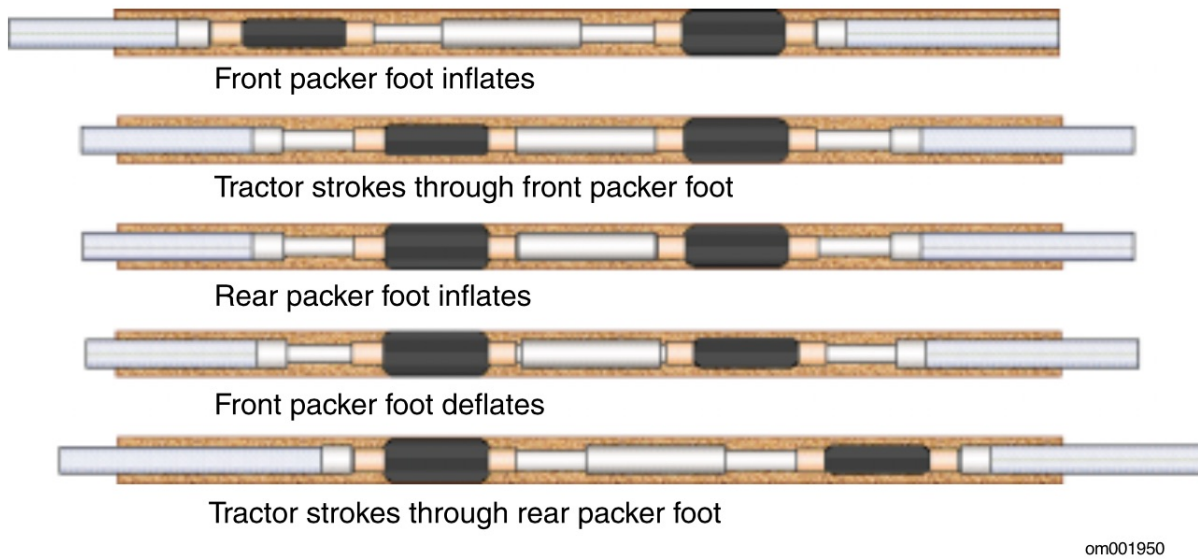

Figure 6.9: Tractor driven BHA (Marker et al., 2000)

6.3 Fiberspar composite coiled tubing

The advanced composite coiled tubing used in Anaconda was developed by Fiberspar together with Halliburton. Although this particular ACCT failed due to the production process, composite coiled tubing has unique properties that can be beneficial in a drilling method where drag and torque limits no longer are design criteria. Composite coiled tubing have a high strength

to weight ratio, excellent corrosion resistance and have an extremely high limit for fatigue. This is because composite coiled tubing is made of reinforced polymers. These polymers are epoxy resins reinforced with continuous high strength, low density fibers such as carbon (graphite), aramid (Kevlar) and glass (s-2 e-glass). Different combinations of these materials allows the composite coiled tubing to be designed and engineered to serve specific purposes and provide optimal performance for particular applications (Rispler et al., 1998). A summary of the characteristics of a 1.5" OD composite coiled tubing design by Fiberspar is seen in table 6.3.

Table 6.3: Performance properties comparison between composite CT and steel CT (Rispler et al., 1998)

	Composite CT		Steel CT
OD (in.)	1.50		1.50
ID (in.)	1.00		1.29
Wall thickness (in.)	0.25		0.109
Linear weight in air (lb/ft)	0.54		1.66
Temperature range	70F	250F	
Burst pressure (psi)	19600	13000	9710
Operating pressure	6000	6000	5000
Ultimate tensile load (lb)	14500	9800	35500
Ultimate tensile yield (lb)	N/A*	N/A*	31930
Ultimate compressive load (lb)	16000	10900	N/A
Fatigue life at operating pressure (cycles)	>5000	>5000	63

*Composite coiled tubing is elastic to failure, and does not have a classical yield point as steel.

The materials that provides the inner surface of CT has less fluid friction than steel CT. Frictional pressure losses are therefore lower in composite CT than steel CT with the same inner diameter. Experiments were conducted by measuring the difference in pressure loss between steel tubing with 1" ID, a smooth roughness value of 0.0018" and the same spool geometry and a composite CT of equivalent length and size with the composite CT of same dimensions. This resulted in a 26 % reduction of frictional pressure loss in the composite CT at lower pump rates and a 56 % reduction at higher pump rates. These characteristics are optimal for the dual flow lines in the umbilical of UmbiliDrill since the pressure loss is expected to be high due to the small inner diameter, long drilling distance and cuttings in the return flow. Two composite coiled tubings of the size as in table 6.3 could be imbedded in a reinforced composite material along with electricity and fiber optic lines to form an umbilical with an outer diameter of at least 3".

6.4 Reelwell Drilling Method

6.4.1 System description

The benefits of a having mud supply and return inside a single string, managed pressure drilling capabilities and continuous circulating capabilities that is part of the UmbiliDrill vision are evident in the Reelwell drilling system. Vestavik et al. (2009) provides the following description. The Reelwell system can be seen in fig. 6.10. It uses a dual drill string consisting of two concentric pipes. A smaller diameter pipe is fitted inside a standard 5" drill string. Drill fluids are pumped through the annulus between the outer and inner string and return is taken through the inner string. The open hole annulus is filled with a higher density kill mud and is separated from the flowing drilling fluids by a sliding piston. This piston can be operated to allow flow from the dual float valve and into the annulus above the piston. The annular kill mud is filled by pumping through the drill string, out the dual float valve and through the piston into the annulus. Pressure can be set on the piston through the annulus making the drill string function as a cylinder. The sliding piston can therefore give extra control over the WOB if required. The dual float valve is integrated in the crossover between the dual drill string and the BHA and can be operated to direct flow through any flow path. It also has the function of keeping the bottom hole pressure constant when shutting off circulation by not allowing flow in any direction. The rotating control device isolates the pressure inside the annulus. The return at the top is directed through a top drive adapter that is made up to the conventional top drive system. The return flow is directed into a choke system that adds managed pressure drilling capabilities to the system. The computerized choke along with the hydraulic system in the open hole annulus is used to keep the bottom hole pressure constant at all times during drilling (Rajabi et al., 2010).

6.4.2 Benefits of the Reelwell Drilling Method

As the fluids are circulated inside the dual drill string and the need for a riser and all riser related equipment in subsea wells are eliminated. This opens up capabilities for smaller less expen-

sive rigs to be used with much less difficulties and technical limitations. Conventionally the latest generation colossal rigs are used to accommodate the riser, tension the riser and precisely positioning the rig. (Rajabi et al., 2010)

The MPD capabilities that the top drive adapter provides along with the annulus hydraulic system (figure 6.10) reduces non productive time caused by bottom hole pressure related issues. Drilling through formations with narrow pressure windows can be done more safely and is used as means to reach drilling objectives that otherwise would be inaccessible. MPD also helps to avoid common drilling issues as differential sticking and unwanted influx or fluid loss. Influx that can lead to kicks are detected immediately due to the small dual string annulus and choke system. Formation integrity is upheld in narrow pressure windows when circulation is stopped thanks to the dual float valve that closes. Open hole pressure is regulated by the mud weight in the annulus and the hydraulic system. (Rajabi et al., 2010)

The continuous circulation system is not exclusive to the Reelwell drilling method. NOV has a rig-floor device that allows for continuous circulation during connections. The benefits of this system applicable to UmbiliDrill is described on the NOV website (National Oilwell Varco, 2014) and summarized here:

- ECD management
 - Continuous hole cleaning
 - Maintains borehole stability
 - Provides a steady loading of the mud cleaning equipment
 - Maintains an even temperature throughout the annulus
 - Enables drilling through narrow pressure window formations
 - Provides an even distribution of cuttings throughout the annulus
 - Near steady state circulating conditions (reduced surge and swab effect)
- Time
 - Reduces drilling duration and program disruption
 - Eliminates changing mud weights while tripping an open hole

- Fewer stuck pipe incidents
- Saves time for testing, and handling of connection influx
- Eliminates stop/start pressure transients
- Well quality
 - Improve hole condition and ability to step-out in ERD wells
 - Reduces reservoir and hole damage
 - Reduces formation stress, improves borehole stability
 - Reduces cuttings bed formation in lateral and ERD walls
 - Reduces the likelihood of a stuck bit or BHA
 - Improved bit penetration rate
- Well control and safety
 - Kicks are less likely due to absence of stop/start pressure transients
 - Kicks are easier to identify in the absence of stop/start transients
 - Immediate response to kicks as drill pipe is always connected to the mud supply
- Cost savings
 - Increase drilling length, potential to reduce mud weight
 - Increased equipment lifetime, especially with HT wells
 - Lower drilling fluid costs
 - Reduction in drilling problems
 - Increase production due to less reservoir damage
 - Develop previously un-drillable reserves

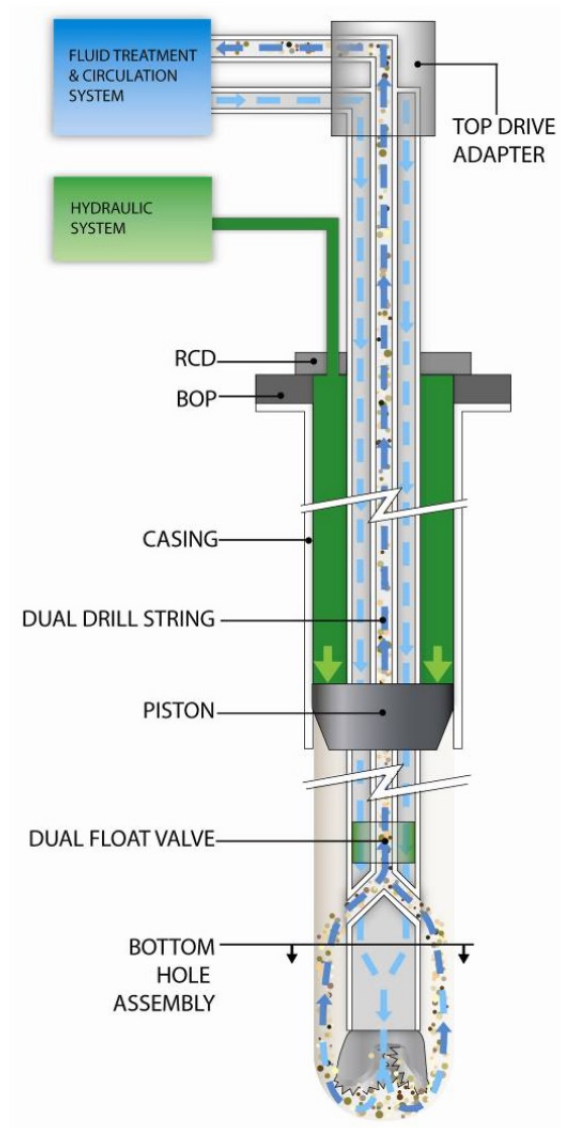

Figure 6.10: Schematic depicting the Reelwell Drilling Method (Phillips et al., 2000)

6.5 Nordhard Norwegian Hard Rock Drilling

6.5.1 General

Nordhard is one of Aarbakke Innovations technology partners and are involved in the development of UmbiliDrill. Nordhard is a company that uses the same ideas presented in 5 with respect to an all electric drilling machine that uses a tractor and a non-rotating drill string. The difference is the scale and area of use. The Nordhard drilling system is currently only used for drilling tunnels from a lower-lying position to the bottom of a higher-lying water source for hydroelectric power. These tunnels have diameters of 700 mm or 27,56". According to Nordhard, the main characteristics of the system is (Nordhard, 2014a):

- Exclusively electrically driven equipment
- Non-rotating drill string
- Drilling at an upwards incline of a few degrees
- Continuous real time telemetry for directional control and position
- On-line high speed communication between remote equipment in the mountain tunnel and operator outside
- No non-environmental discharge
- No excessive noise or vibrations to surroundings

6.5.2 Drilling system description

The drilling machine uses a conventional bit and reamer to drill tunnels with 27,56" diameter capable of departures up to 1000 m. Tunnels can be drilled with build-up curves of 200-300 m radius. This is equivalent to a positive incline of 4 degrees typically. The ability to use this system to drill horizontally and at a negative is currently under development. The position and direction of the drilling machine is continuously monitored and results in an accuracy of 2 m offset per 1000 m drilled. The cuttings are circulated with water and sedimented in a pond

where the clean water is recirculated. (Nordhard, 2014c)

The reason why the Nordhard drilling system is relevant to UmbiliDrill is that it uses a tractor functioning as a hydraulic drill collar and a motor that is driven electrically using a custom built permanent magnet motor (Nordhard, 2014b). The tractor functions principally in the same way as the WWT tractor or Kolibomac by having a anchoring mechanism clamped against the bore hole wall to supply axial force and take up torque from the drill bit. As there are no requirements for pressures in the open hole, water can be pumped through tubulars that are clamped on the outside of the drill string (Haughom and Knutsen, 2011). This is also true for electrical and signal cables. The drill strings no longer have to be tubulars, but can instead have other more convenient cheaper designs such as an H-beam (Haughom, 2014).

6.5.3 Use of a permanent magnet motor

This tractor is hydraulically operated and powered electrically by a custom made permanent magnet motor. This type of permanent magnet motor is designed manufactured by the company SmartMotor. SmartMotor also provides the motor for the Badger drilling system. This is also a drilling system that uses a tractor working on the same principles as the WWT, Kolibomac and Nordhard tractor, albeit on a smaller scale. The same type of motor should therefore be applicable to UmbiliDrill. The motor specification for the Nordhard drilling machine is shown in table 6.4. The air gap shear stress is often used as a motor constant referring to the compactness of the motor and is calculated as follows:

$$\text{Air gap shear stress} = \frac{T}{2\pi r_{lg}^2 L} \quad (6.11)$$

T = Torque (Nm)

r_{lg} = Radius to air gap or the rotor radius

L = Active length

If the air gap shear stress is known it is possible to re-scale the motor size by using the air gap shear stress as a constant. By inserting the torque from table 6.4 and the new desired radius into equation 6.11 it is possible to find an estimate of the new length and the stator radius. The re-scaled stator radius is found by keeping the same rotor to stator radius ratio as the original motor. These values are only rough estimates. However, it is possible to find an estimate of the necessary motor length that is required for UmbiliDrill with the same torque capabilities as the Nordhard motor.

Table 6.4: Nordhard permanent magnet motor specifications (Kvåle, 2015)

Nordhard permanent magnet motor specifications	
Power (kW)	29
RPM (rpm)	690
Torque (Nm)	400
Outer diameter of stator (mm or in)	265 or 10,43
Length of active (mm or in)	630 or 24,80
Air gap shear stress (N/m^2)	9525
Rotor diameter (mm or in)	206 or 8,11

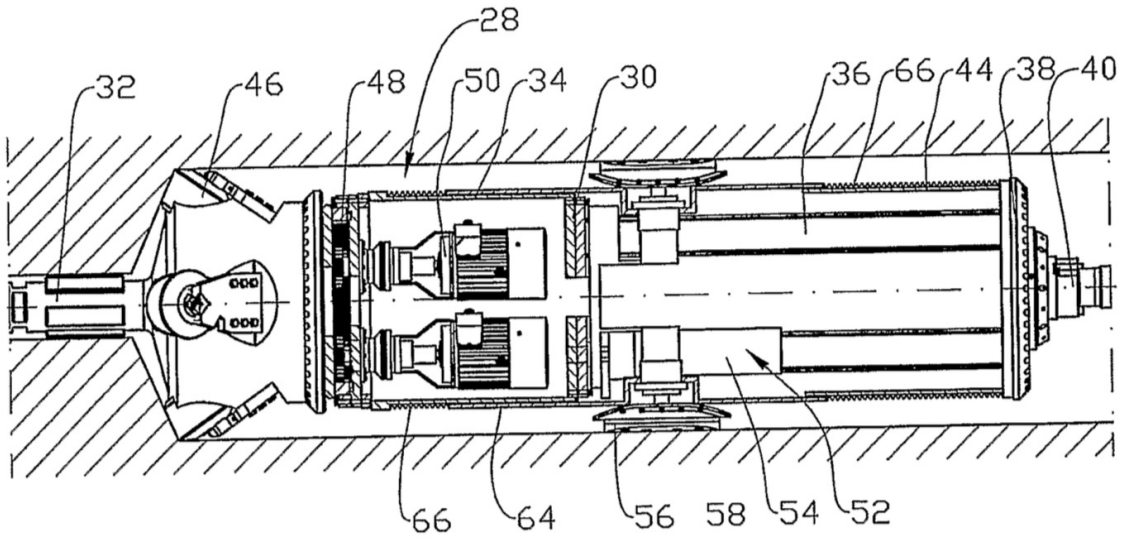

(a) Nordhard tractor patent schematic with extended feet

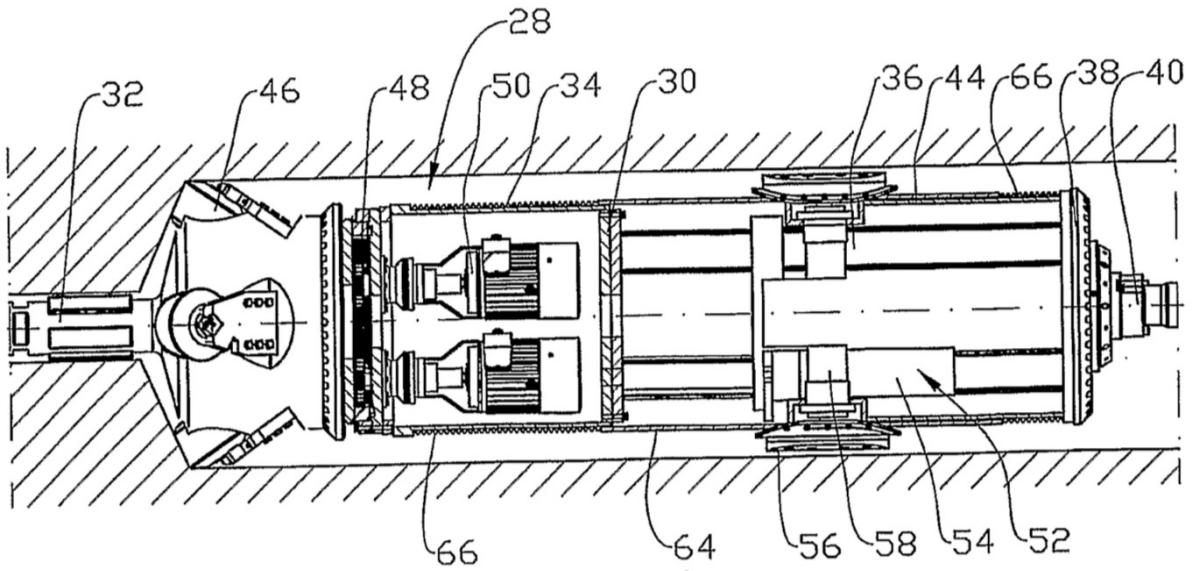

(b) Nordhard tractor patent schematic with retracted feet

Figure 6.11: Nordhard Norwegian Hard Rock Drilling patent schematic for tractor in use (Haughom and Knutsen, 2011)



(a) Nordhard tractor feet photo



(b) Photo of Nordhard tractor module



(c) Photo of Nordhard tractor module

Figure 6.12: Nordhard Norwegian Hard Rock Drilling tractor which is currently in use. Photos taken by author at Nordhard headquarters in Tonstad, Norway

Chapter 7

Case Analysis - Theoretical performance analysis of UmbiliDrill in a through tubing multilateral well by Statoil on Norne

7.1 Introduction and summary of operation

Now that the vision of UmbiliDrill and its advantages have been supported by the similar technologies reviewed in chapter 6, it is possible to analyze a theoretical drilling performance in an actual drilling case. Any mention of the drilling program in this chapter is accredited to Klaussen and Borlaug (2009). This case will be a Through Tubing Multilateral (TTML) well on Norne provided by Statoil. The well was drilled to compensate for the very high water cut in the main bore. The multilateral was drilled without pulling the completion, making it a through tubing drilling operation. A packer was set in the 7" liner to isolate the mother bore. A retrievable oriented whipstock was installed above the packer and a window was milled in the liner and production casing. A 5 3/4" sidetrack was drilled through the milled window and geo-steered into a different reservoir segment with a lower water cut. This reservoir segment was produced on its own until the water cut reached the same level as in the main bore and the reservoir could be produced

from both wells.

This case and the data available in the drilling program will be used to make an evaluation of the performance between conventional through tubing rotary drilling and UmbiliDrill in a real scenario. The assessment will concern the challenges that the engineers foresaw and prepared for during the planning of this multilateral well and how UmbiliDrill can find solutions or improvements to these challenges based on the theory in the previous chapters.

The case analysis will also concern how the UmbiliDrill system will behave in accordance with the general requirements for a successful drilling operation. These requirements are the drilling systems ability to:

- cope with the torque and drag generated by the frictional forces encountered while drilling, running in hole and pulling out of hole
- stay outside the buckling limit
- withstand the hydraulic pressures generated by circulating the drill fluid
- keep the ECD within the collapse pressure and fracture pressure of the formation
- have a high enough drilling fluid flow rate for cuttings transport

A special note for the UmbiliDrill system will be to see if the down hole tractor has a high enough output to pull the umbilical while also being able to exert enough weight on bit. A section is dedicated to calculate the no-slip condition and tensile stress on the Kolibomac inflatable packers in case this technology is to be used in the UmbiliDrill system.

Calculating estimates of the torque, drag, buckling limit, hydraulic pressure loss, ECD and cuttings transport ability will indicate if UmbiliDrill can fulfill the requirements listed above. This will also shed light on any short comings or advantages of the system. Calculations of estimates based on the same requirements will also be done for conventional drilling and compared to UmbiliDrill.

7.2 Operational challenges

The following sections describe the operational challenges that were thought to be important when planning a TTRD operation on Norne (Klaussen and Borlaug, 2009). These challenges will give some insight into where similar challenges can occur when using UmbiliDrill or where UmbiliDrill can improve challenges.

7.2.1 Maintain completion integrity

In any TTRD operation maintaining the integrity of the in-place completion is a top priority. In the drilling program it is stated that it is not possible to prevent mechanical wear caused by rotation and side forces. The only option is to protect the most critical components and to distribute the wear evenly in the remaining tubing string. Protective sleeves in the wellhead area, BOP and down hole safety valve must be installed. The maximum amount of tubing wear for this operation was calculated to be 13% at 710 m Measured Depth (MD). If experience from a similar operation shows more excessive wear than predicted an ultra sonic imaging tool should be run to check the actual tubing wear.

The tubing used in the in-place completion on the Norne mother bore is a 7" 13 Cr-80 FOX tubing with a minimum yield strength of 80000 psi and thickness of 0,408". According to the API burst rating formula, eq. 7.1, the burst rating of this tubing is equal to 9326 psi. With tubing wear of 13% this burst rating is reduced to 8113 psi by making the tolerance equal to 0,87.

$$P_b = SF \frac{2\sigma_y t}{D} \quad (7.1)$$

P_b = Burst pressure rating

SF = tolerance

σ_y = minimum yield strength

D = outer diameter of tubing

t = wall thickness

The UmbiliDrill system has the advantage of not causing any tubing wear, based on the experience from Anaconda and composite coiled tubing drilling. Tubing wear is also a function of the number of tool-joint rotations. UmbiliDrill does not rotate and does not have any tool-joints. Tubing wear will therefore not be an important operational challenge. Distributed sensing from the fiber optics can be used to continually monitor the integrity of the completion during drilling.

Important equipment such as the surface BOP, tubing hanger and down hole safety valve is very important to protect regardless of drilling method. A wear sleeve will be installed in the BOP and remain there as long as the operation is in drilling mode. To protect the tubing hanger and the down hole safety valve wear sleeves are installed. For TTRD the wear sleeves are installed in tandem on a running tool with shear pins as part of the drill string above the BHA. This means that there is no protection for the tubing hanger and down hole safety valve when running in the BHA before the sleeves are installed. Any rotation of the string can cause movement of the flowtube in the safety valve. If the flowtube is removed from a position where it denies the flapper valve to close, a situation of severe damage and possible stuck pipe can occur. The only way to avoid damage is to lower the string with limited speed, have the heave compensator activated and the rig in optimum position. Using correct tallies, limited run speed and limited appliance of force is extremely important.

If using UmbiliDrill for this operation the same precautions have to be made when running in hole with the BHA. However, wear sleeves cannot be run as part of the drill string, but can be run as part of the BHA. This has to be researched more at a later development stage. Wear sleeves can be installed prior to running in hole with the UmbiliDrill system. They can be installed as part of the clean-out run or on wireline.

7.2.2 Directional drilling

Geo-steering the side track in this operation required an onshore team working 24/7 to support the rig when drilling the reservoir section. This is because previous experience from Norne is that the hole inclination has to be changed rapidly to keep the well path in the oil bearing zone. This can increase the tortuosity of the well which increases the frictional drag in the well bore. There have also been issues with steering through horizontal stringers in the reservoir formation.

For directional drillers to accurately hit targets and stay within the target interval real time telemetry data can be very beneficial. In conventional directional drilling surveys are sent to the directional driller every now and then using mud pulses to check the bit position in relation to the shale above. Having this data in real time will allow the driller to react quicker and steer the side track more smoothly and accurately. The correct placement of the side track in the reservoir section is also very important to maximize production. Due to the electrical system and fiber optics in UmbiliDrill, this system is better equipped to handle challenging directional drilling. It may also alleviate the need for a 24/7 onshore geo-steering support team.

7.2.3 Stuck pipe

There are two types of stuck pipe that needs to be addressed. The first is differential sticking where the well bore pressure is greater than the reservoir pressure and the pipe sticks to the well bore wall. This is considered a risk in areas where the reservoir pressure is reduced. In the Norne well there are sandstones with an overbalance of ± 130 bar and differential sticking is considered a risk. The chance of getting stuck is also increased when circulation and rotation is stopped allowing the string to rest against the well bore wall. Indicating factors of differential sticking is unexpected increase in torque and drag. Therefore in this TTRD well, torque and drag had to be recorded prior to every connection in the expected trouble zones.

UmbiliDrill utilizes a closed circulating system with active pressure management. There are

also no connections. UmbiliDrill can therefore actively adjust the well bore pressure above the BHA using back pressure from topside while adjusting the flow and ECD in the BHA annulus to minimize the risk of differential sticking in any situation.

Getting mechanically stuck is an equal risk for both drilling methods. Based on previous experience of TTRD operations conducted by Statoil, it is reasonable to assume that mechanically stuck pipe is most likely to occur in the milled window or in the downhole safety valve. Getting stuck in open hole is also a risk and can never be completely ruled out. To minimize the risk of getting mechanically stuck Statoil has provided in the drilling program a number of guidelines. These are applicable to UmbiliDrill as well.

- The well will be drifted in a separate run.
- Prior to each run, the maximum outer dimension of all down hole equipment must be verified and compared to restrictions in the well.
- In addition to limited running speed, heave compensation must be activated prior to run BHA through restrictions and/or exposed completion components. This requirement is applicable for every string component with a significant upset, such as wear sleeve and liner hanger.
- If hung up, only limited pulling force shall be applied. The pulling force limitation must reflect the weakest point in the string as well as the consequence of damaging the completion components. A rule of thumb is to always be able to lower the string out of the restriction. Getting the string stuck while pulling, or pulling until something yields, is not considered the best practice.
- Experience shows that jarring down is often the best way to free the string.

7.2.4 Hole Cleaning

The drilling program states that hole cleaning is not the most challenging part of the TTRD operation. This is due to the narrow annulus and the corresponding high annulus velocity. This does not, however, reflect the importance of hole cleaning. In a long horizontal departure with

a narrow annulus it is extremely important to have a clean hole when running the completion. Especially in this well where 4 1/2" x 4" liner with swell packers and 4" screens in a 5 3/4" open hole must be run to TD. Proper hole cleaning for this operation requires a high annular fluid velocity, string rotation and time in general. The last two are limited by the fact that this is a TTRD operation where rotation is harmful to the in-place completion and that spending a lot of time can become very costly due to high rig rates.

Whether or not the UmbiliDrill system can achieve the same annular fluid velocities in the BHA interval as the TTRD BHA needs to be more closely examined. The flow area of the BHA annulus is the same in this scenario for both methods. However, the inner flowlines of the UmbiliDrill umbilical is relatively small. The flow rates required for adequate hole cleaning in the annulus may become too great for the umbilical to handle. On the other side, the small diameter flow line increases the hole cleaning ability above the BHA.

7.2.5 Formation integrity and stability

Hole stability issues are often unique to the different formations that are drilled through. On Norne experience indicates that in high inclination well bores a mud weight of at least 1,25 s.g. is needed to maintain bore hole stability. For this well a mud weight of 1,44 s.g. was chosen with an expected ECD of 1,57 s.g. at TD. A formation integrity test of 1,62 s.g. estimated mud weight will be performed below the casing window before starting to drill. At the milled window depth the leak of test is expected to be 1,78 s.g. and the weakest formation has an expected leak of test of 1,68 s.g.. According to these parameters the hole should be pretty stable, but it is still important to follow good drilling practice and minimize total exposure time and cyclical loading to reduce the risk of hole stability problems.

In UmbiliDrill the same mud weight could be used as the static fluid in the annulus above the BHA. There will also be limited cyclic loadings in this area because there are no circulation stops and starts that reduce and increase ECD respectively. The ECD of the flowing fluid can be accurately controlled by varying the flow rate, mud weight or manipulating the choke in the return

flow.

The formation integrity will also be affected by the tractor used in UmbiliDrill. A thesis by Flateboe (1999) simulated the effect of a Kolibomac-based tractor with many feet as contact points instead of a uniform packer on the bore hole. The normal stresses of the tractor feet were calculated against the critical shear stress of the formation. At low well pressures the tractor will have a supporting effect on the bore hole, but if the tractor force is increased enough it is possible for the shear stress at the edge of the tractor feet to exceed the critical shear stress of the formation. The analysis made by Flateboe (1999) also shows that the tangential stresses go into tension at lower well pressures when the tractor is applied. This is a function of the tractor force and the well pressure. In the analysis the initiating fracturing pressure was reduced when using a tractor.

When a fluid filled material in equilibrium experiences an external force on a point, a new pressure distribution will appear around this point. To equalize the pressure a transient fluid flow will take place until equilibrium or steady state conditions are established. A tractor with feet will cause pressure build up the moment it is applied to the wall. During the transient period the radial stress may become tensile between the feet causing scaling of the bore hole wall. This is demonstrated in the thesis and is a function of the tractor force, how fast the tractor is applied to the wall, the area of the feet and the permeability. Transient pressure build-up between the feet can cause scaling that get the tractor stuck. Transient pressure build-up effects can be limited if the tractor is applied in steps allowing the pressure to be equalized before scaling becomes an issue.

These effects need to be simulated and analyzed for the specific tractor that is used, the formations that are drilled and the well pressures that are expected. The effects will vary for different tractor types. The Kolibomac tractor with a uniform inflatable packer does not have any edges or gaps that can cause tension in the bore hole. The Anaconda tractor by Western Well Tools will experience these issues as this has separate feet with gaps in between. The bottom line is that using tractors can affect the bore hole by lowering the fracture initiation pressure that can cause unexpected fluid loss scenarios. A stuck tractor due to scaling can jeopardize the entire operation by not being able to retrieve the drill string.

7.2.6 Drill string

Compared to equipment used in a conventional well, the string components in a TTRD well are less rigid. Pipe handling equipment is capable of applying damaging force to the equipment if care is not taken. The combination of slim hole equipment, friction and powerful surface equipment demands high focus to avoid exceeding the yield stress of the drill pipes.

UmbiliDrill uses a down hole tractor with weight sensors on either side that communicates with the reel on surface to ensure at all times that the yield stress in the umbilical or any other equipment is never exceeded. Constant communication between the surface and down hole equipment will ensure that the umbilical is always in tension with the tractor doing most of the work to "walk" in and out of the hole.

7.3 Evaluation of sequence of operations in a through tubing drilling operation

There is an established necessary sequence of operations for preparing the well for a through tubing drilling operation and for drilling the side track. This is an attempt to evaluate how UmbiliDrill will play a part in these sequences. Note that these evaluations are preliminary and based on assumptions and should be regarded as such. The sequences described in this section are the same as the ones described in the Norne TTML well drilling program (Klaussen and Borlaug, 2009). These sequences are based on the experiences gathered by Statoil supported by the recommended practices in the presentation by Andersen (2015a).

The sequence of operations along with the main objective of the specific operation are listed as written in the drilling program below.

1. Open hatch - Move rig to correct template, hand over well from Norne PSV. Perform dynamic position trial. Open hatch and remove tree debris cap.

2. Pull internal tree cap with open water tree cap retrieval tool - Pull Internal Tree Cap (ITC) with Open Water Tree Cap Tool (OWTCT).
3. Run TTRD equipment - Run TTRD equipment including lower riser package, Merlin riser, surface BOP, high pressure casing and surface flow tree. Land and lock same in intervention mode.
4. Pull tubing hanger crown plug and install tubing hanger nipple protector - Retrieve Tubing Hanger Crown Plug (THCP), displace Work Over Riser (WOR) to base oil, perform inflow test and install Tubing Hanger Nipple Protector (THNP).
5. Run multi finger calliper on extended wire line tractor - Main objective is to measure ID of 7" tubing and 7" liner, and to verify that there are no restrictions or scale in the well prior to install the TIW Packer. If the Multi fingered Caliper (MFC) run detects any obstructions or reduction in well ID a clean-up run will be performed prior to install the TIW Packer.
6. Kill Well - Mother bore is filled with hydrocarbons and formation water. The main objective is to kill the well by bull-heading MEG, base oil, SW, kill-pill and Oil Based Mud (OBM).
7. Mill scale inside tubing (contingency) - Remove scale from wellbore
8. Run and install TIW packer - The TIW Packer will function as a basement for the temporary set whipstock and the MFIV sub assembly will seal off the mother bore reservoir while drilling the lateral section. The TIW Packer will be run with tractor and CCL on electric wireline, and must be installed at ideal depth so the window can be milled without hitting casing collars.
9. Check orientation of TIW Packer - The main objective with this run is to check the orientation of the TIW Packer, to verify that the TIW Packer is properly set and to close the MFIV sub assembly.
10. Run whipstock and mill window - Install a temporary set whipstock with milling latch and debris barrier. Mill window through 7" liner and 9 5/8" casing.
11. Drilling 5 3/4" Hole - Drill 5 3/4" hole section to TD at ± 4316 m MD / ± 2598 m TVD and circulate hole clean
12. Run lower completion - Run and install 4" screens, blank pipe, swell packers and 3,375" PBR. Swell packers are run to isolate the depleted formation.

Points 1 and 2 would probably have to be done according to standard procedure using standard drill pipe and the lifting system on the drill floor. According to the Reelwell method, a system with mud circulation inside the drill string does not require a high pressure riser or casing when drilling. However, for a through tubing operation there is need to kill the well with bullheading. This requires at least a high pressure casing to circulate through. It is unlikely that UmbiliDrill could accomplish this on its own due to the flow rates and pressures involved. Therefore, point number 3 is an entirely necessary operation even when using UmbiliDrill. This would have to be accomplished using conventional methods.

Operation number 4 would also most likely have to be accomplished using conventional methods.

Operation number 5 (Run caliper on wireline (WL) tractor) could be postponed until after operation number 6 (Kill Well). Operation number 5 could also be accomplished using UmbiliDrill. This means that the UmbiliDrill system would have to be rigged up after killing the well and a compatible multi-fingered caliper tool could be made up to the UmbiliDrill BHA. This would save time on wire line rig-up and this time could be allocated to rigging up the UmbiliDrill system. Killing the well would have to be done using conventional methods. Doing this means that UmbiliDrill would have to be used to complete operation number 7, 8, 9 and 10. They could be accomplished using conventional methods if the rig allows for quick interchangeability between UmbiliDrill and conventional methods. This is something that must be looked into in the further development of UmbiliDrill.

However, if UmbiliDrill were to be used to complete operations 7, 8, 9 and 10 it must be able to perform equally as well as conventional methods. Milling scale could be done by making up a compatible milling assembly to the UmbiliDrill BHA and use the electrical motor to drive the assembly. The tractor would have to be engaged as well to prevent buckling in deviated wells and take up the resultant torque from the milling assembly. Running and installing the TIW packer is done on wire line and tractor and can therefore be assumed to be accomplished with UmbiliDrill as well. Checking the orientation and verifying that the packer is properly set is done on drill string by using special tools attached to the BHA. Weight and orientation could be

recorded by the weight sensors and the positioning sensors in the UmbiliDrill BHA. These will be very accurate due to the high speed data transfer capabilities.

Running the whipstock would probably be possible using UmbiliDrill as well. The tractor applies enough weight for it to lock properly and the motor can be used to rotate it into the correct orientation. Milling the window is accomplishable using a system like UmbiliDrill because it has already been accomplished during testing of the Anaconda system (Marker et al., 2000).

Finally drilling the side track is also accomplishable courtesy of the testing done during the development of Anaconda (Marker et al., 2000).

7.4 Torque and drag calculations

7.4.1 General assumptions

A comparison of the torque and drag performance of conventional TTRD used in this operation and UmbiliDrill does not require the exact same well path as the Norne TTRD well. As long as the well conditions remain the same when calculating torque and drag for both drilling methods it is possible to compare their performance. For simplicity's sake a well profile with a 2000 m vertical section, a 90 degree build up section with a dog leg severity of 3 degrees per 30 meter and a horizontal sail section is used. The vertical section has the same hole size as the tubing used in the Norne well while the 90 degree build up and sail sections has the same 5 3/4 " open hole diameter. The kick off point at 2000 m is imagined as the milled window. A 1000 m horizontal sail section is assumed as a starting point and will be increased to find the maximum horizontal drilling distance for both drilling methods. The drill string and BHA dimensions and yield ratings is the same as for the Norne TTRD well. The UmbiliDrill umbilical dimensions and rating is based on the Fiberspar composite coiled tubing in table 6.3 and the Anaconda advanced composite coiled tubing in table 6.1. The umbilical is imagined to consist of two 1,5" composite coiled tubings imbedded in the same material that the Anaconda ACCT consists of.

The burst strength will be dependent on the composite coiled tubings and the tensile limits are based on the ACCT. A cross-sectional schematic of the imagined umbilical can be seen in figure 7.1

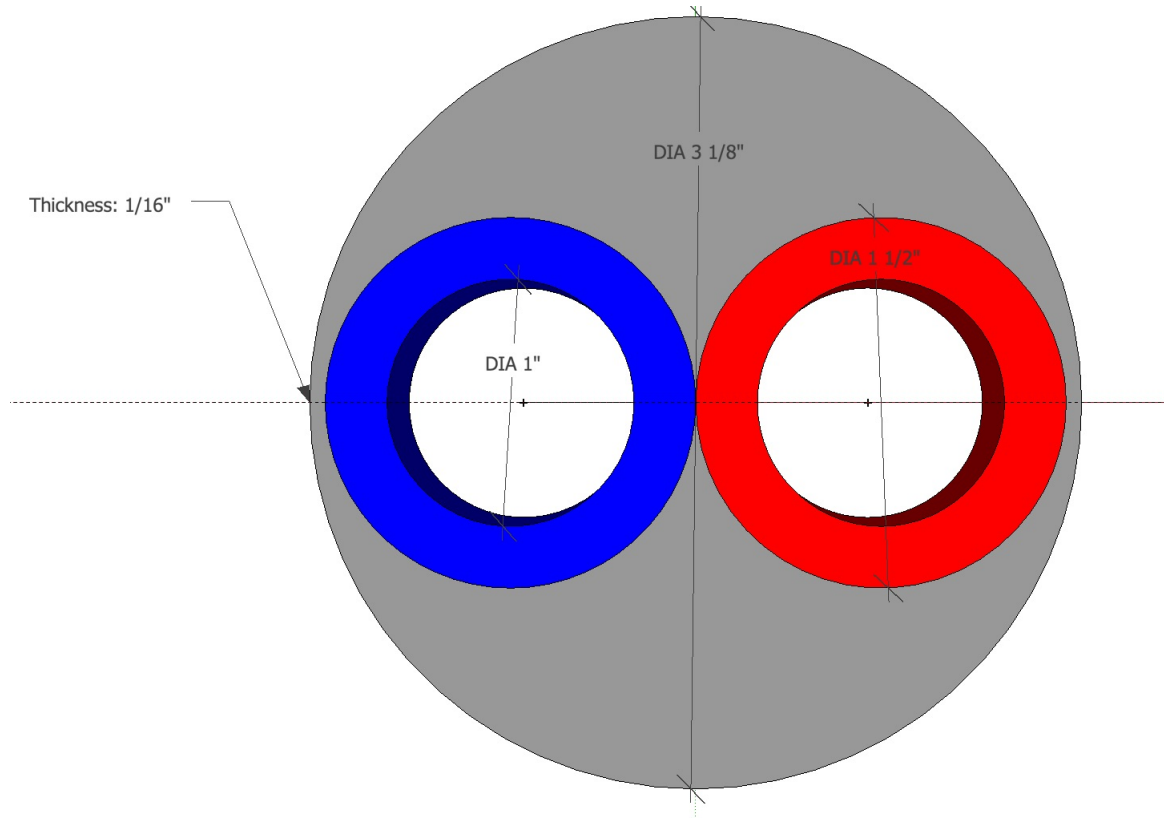

Figure 7.1: A cross sectional schematic of a proposed design for the UmbiliDrill umbilical. The red and blue tubes represent the composite coiled tubing and are imbedded in the grey material which represents the ACCT material

The well data is summarized in table 7.1 and the well path design can be seen in figure 7.2.

Table 7.1: Torque and drag well data

Well Data	
Vertical length, L1 (m)	2000
Tubing inside diameter, D1 (m)	0,1524
Build up radius, R (m)	900
Horizontal length, L2 (m)	1000
Open hole diameter, D2 (m)	0,14605
BHA length, L3 (m)	200
Coefficient of friction, μ	0,2
Build up angle, α , (deg.)	90
θ_1 (radians)	$\frac{\pi}{2}$
θ_2 (radians)	0

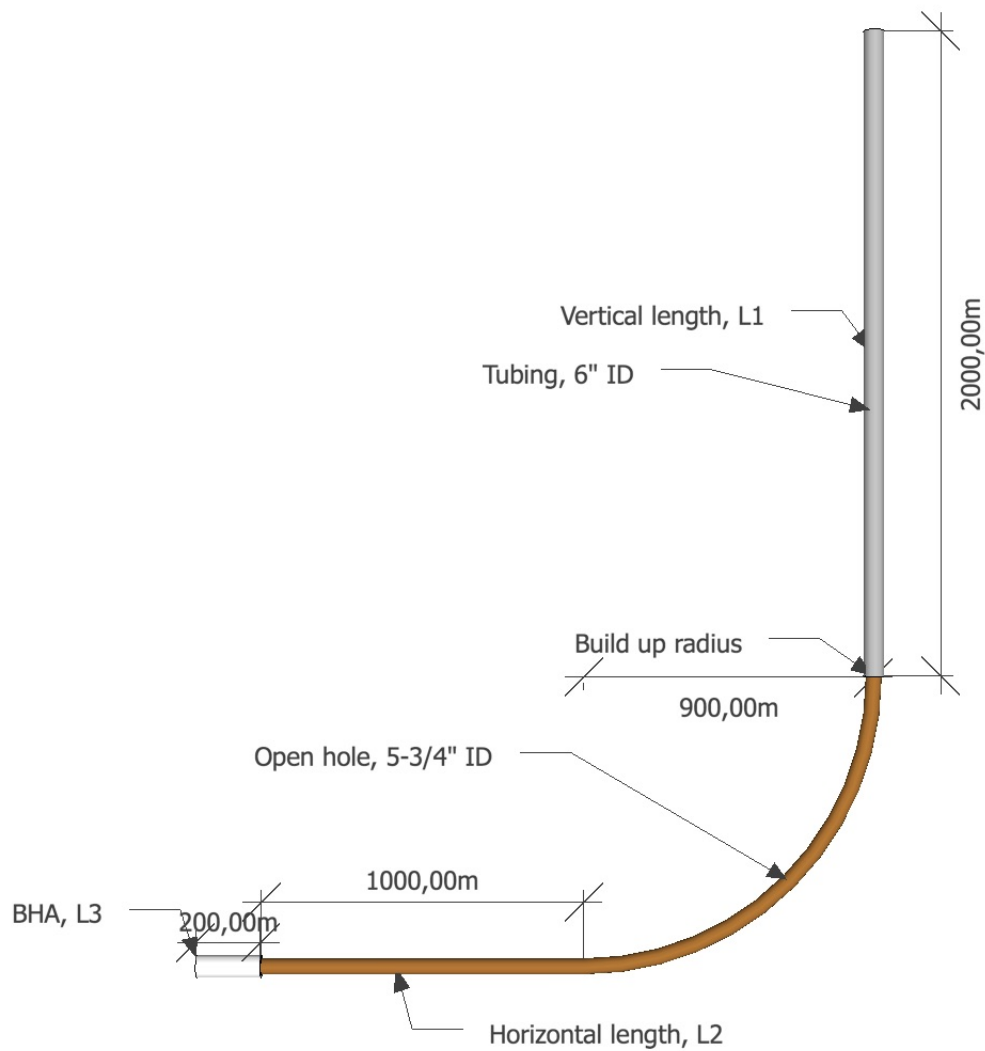

Figure 7.2: Well path design for torque and drag calculations

7.4.2 Torque and drag calculation results for TTRD

The torque and drag is calculated using equations 2.2, 2.3, 2.4 and 2.5. The torque and drag is calculated both with rotation using equation 2.1 and with no rotation. The drill string and BHA data is summarized in tables A.1 and A.2. This data is simplified from the Norne drilling program by replacing the entire BHA with the heavy walled drill pipe used in the BHA. The drill string and hole sizes are the same. The results from equation 2.1 are based on a block speed of 0,2 m/s and rotational speed of 120 rpm, and is summarized in table A.3. Using the string, BHA and well data in the 3D friction equations gives the torque and drag which is summarized in tables A.4 and A.5. The results are visualized in figure 7.3. The tensile limit in this figure has an added safety factor of 2 where $\frac{1}{SF} = \frac{\sigma}{\sigma_{yield}}$ and $\sigma = 1000$. The buckling limits are calculated using eq. 2.7 for the vertical section, eq. 2.8 for the curved section and eq. 2.10 for the horizontal depreature.

7.4.3 Torque and drag calculation results for UmbiliDrill

The torque and drag calculations for UmbiliDrill are done exactly the same as for conventional through tubing rotational drilling. The difference is the mechanism for running in and pulling out of hole. For conventional drilling the torque and drag indicates the weight and torsion measured at the top drive when lifting, lowering and rotating the string. UmbiliDrill does not rotate, however it can be lifted by the reel which is similar to lifting by top drive. UmbiliDrill also utilizes a tractor to pull the umbilical behind itself while pushing the BHA and bit forward. This means that the tractor will be required to have a greater output than the lowering force and the reel has to have a higher output than the pulling force. The torque is not applicable to this drilling method, but it is included for a comparison between a composite material and a steel material. The input data is show in tables B.1 and B.2. The numerical results are shown in tables B.3 and B.4. The numerical results are shown in relation to the buckling and tensional limits in figure 7.4. The buckling limits are calculated with the same equations as in section 7.4.2 and are included to show how a composite umbilical will behave without using a tractor to keep the string

in tension.

The maximum horizontal departure for UmbiliDrill based on tension alone with the assumption that all other input data is constant and the reel can be infinitely big is when $L_2 = 64000$ m.

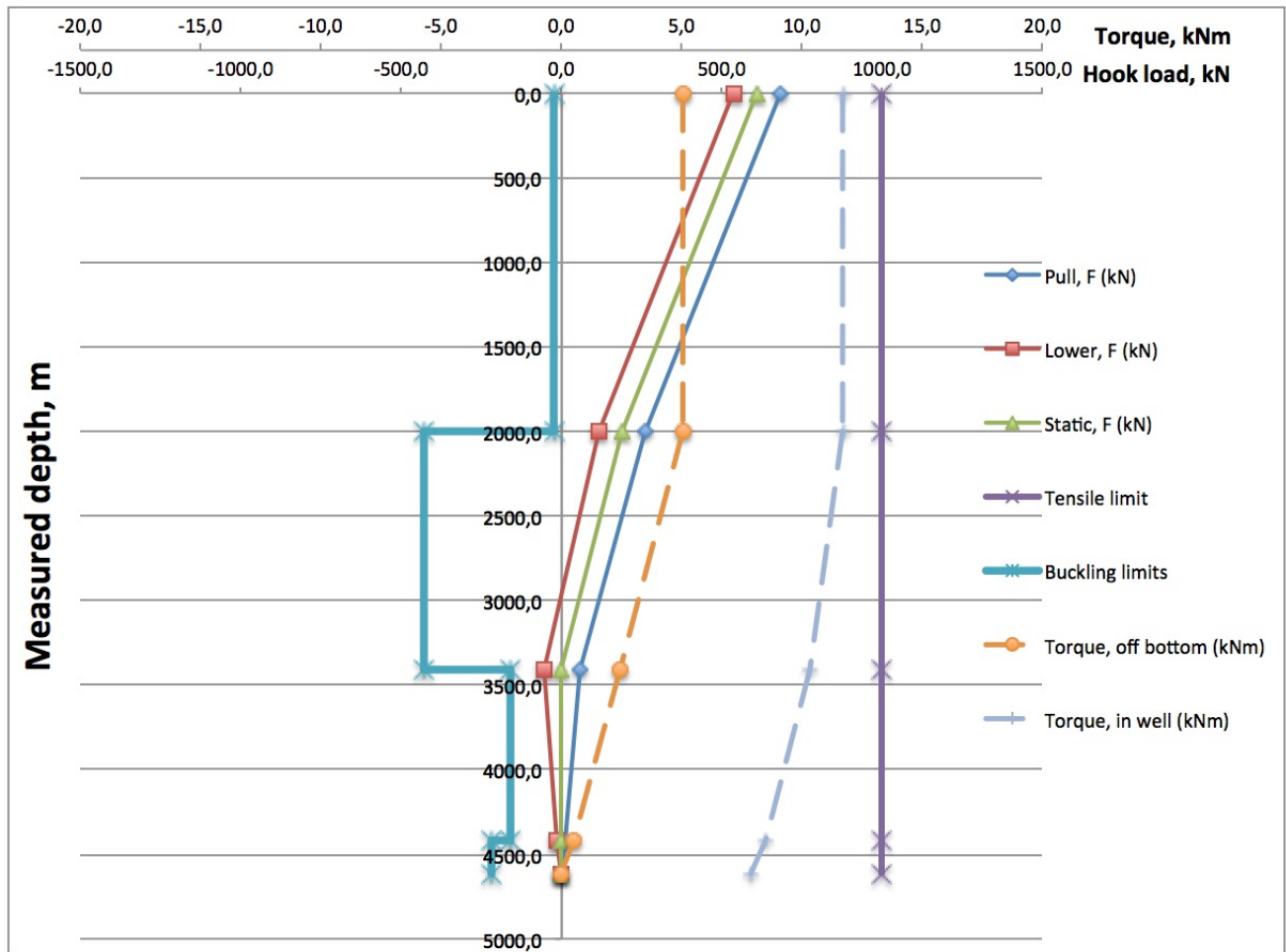

Figure 7.3: Torque and drag results visualized with buckling, torsional and tensile limits for through tubing rotary drilling

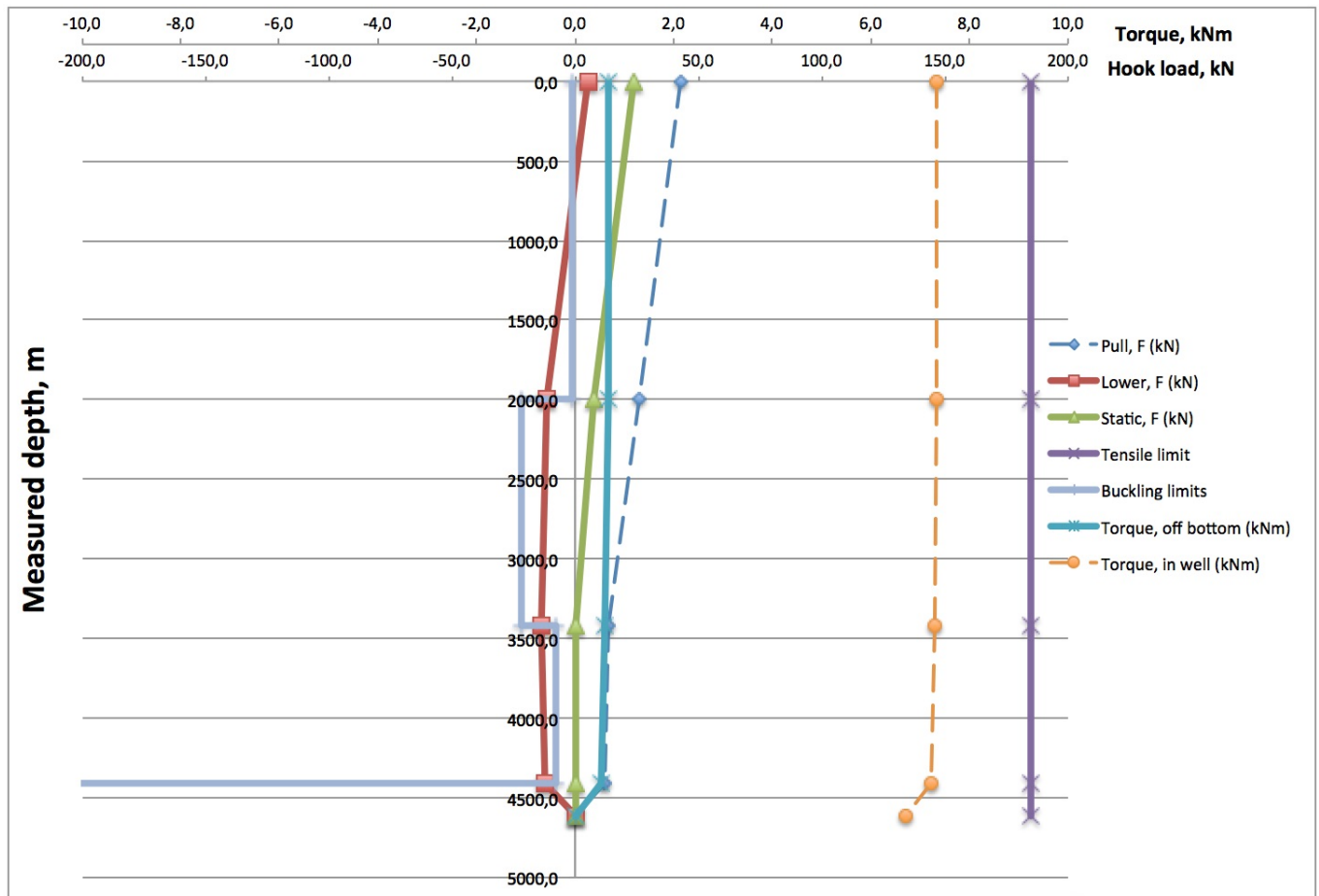

Figure 7.4: Torque and drag results visualized with buckling, torsional and tensile limits for Um-biliDrill

7.4.4 Kolibomac inflatable packer no-slip and tensile stress limit

In this section the no-slip conditions and tensile stress limits for the Kolibomac inflatable packers are calculated. The calculations are based on the ability of the packers to withstand the forces experienced by the drill string when running in hole and pulling out of hole. In addition to overcome the frictional drag in the well bore, the packers also have to be able to apply the same amount of weight as the TTRD which is in this case 5 metric tonnes. It will also be compared to the maximum axial output of the WWT tractor.

The calculations are made in accordance with section 6.1.2. The Kolibomac-packer has been scaled to fit the envisioned diameter of the UmbiliDrill BHA. The equation 6.6 has been rearranged in equation 7.2 and the input factors are seen in table 7.2 where the description for A to F is listed below:

$$\Delta P = \frac{\sqrt{F_t^2 + F_a^2}}{2\pi R \times L_{eff} \times \sqrt{\mu_t^2 + \mu_a^2} \times \cos\left(\tan^{-1}\left(\frac{F_t}{F_a}\right) - \tan^{-1}\left(\frac{\mu_t}{\mu_a}\right)\right)} \quad (7.2)$$

A = Maximum tensile stress from figure 7.4 and bit torque from drilling program

B = Maximum tensile stress from figure 7.4 and bit torque from motor in section 6.5

C = Axial force from weight on bit requirement from drilling program and bit torque from drilling program

D = Axial force from weight on bit requirement from drilling program and bit torque from motor in section

E = Maximum output of the WWT tractor from table 6.2 and bit torque from drilling program

F = Maximum output of the WWT tractor from table 6.2 and bit torque from motor in section

The external pressure, P_e , is the hydrostatic column of 1,44 s.g. drilling fluid in a 2900 m true vertical depth well as in the other sections. The no-slip condition will be calculated with and without the external pressure. The results of the calculation can be seen in table 7.3.

The tensile stress for the same A-F scenarios as listed above are carried out using the equations

Table 7.2: Input factors for no-slip condition of Kolibomac inflatable packers

Input factors for no-slip:	A	B	C	D	E	F
External pressure, Pe (Pa)	0 or 40966560	0 or 40966560	0 or 40966560	0 or 40966560	0 or 40966560	0 or 40966560
Crown radius, R (m)	0,16	0,16	0,16	0,16	0,16	0,16
Effective packer length, Leff (m)	0,6	0,6	0,6	0,6	0,6	0,6
Coefficients of Friction, u	0,3	0,3	0,3	0,3	0,3	0,3
Axial force, Fa (N)	43000	43000	50000	50000	64500	64500
Torsional moment, Mt (N/m)	3000	400	3000	400	3000	400
Torsional Force, Ft (N)	18750	2500	18750	2500	18750	2500

Table 7.3: Minimum internal packer pressure required for no-slip condition

Minimum internal packer pressure required for no-slip condition		
Scenario	Pe = 0	Pe = 410 bar
A	1,97 bar	411,6 bar
B	2,25 bar	412,5 bar
C	2,29 bar	412,3 bar
D	2,64 bar	412,6 bar
E	2,99 bar	413 bar
F	3,44 bar	413,5 bar

6.7, 6.8, 6.9 and 6.10. The variable input factors for axial force and torsional moment are the same as in table 7.2 and the internal packer pressure is taken from 7.3. The other constant input factors are listed below:

Cross-sectional area of cord, $A_{cord}(m^2) = 0,00000113$

number of cords, $n = 150$

Cord angle, $\theta = 0,34906585$

Packer radius, $R_o (m) = 0,088$

Mandrel radius, $r_m (m) = 0,0616$

Packer mandrel radius ratio, $x = 0,7$

Tensile strength of cord, (bar) = 15800

The results of equation 6.10 are summarized in table 7.4.

Table 7.4: Tensile stress experienced by the reinforcing Aramid fiber cords in inflatable packer

Tensile stress experienced by the reinforcing Aramid fiber cords in inflatable packer		
Scenario	Pe = 0	Pe = 410 bar
A	1957 bar	17913 bar
B	1371 bar	17328 bar
C	2163 bar	18119 bar
D	1581 bar	17537 bar
E	2592 bar	18549 bar
F	2014 bar	17969 bar

7.5 Hydraulics

7.5.1 General

The pressure loss in the fluid circulation systems of both conventional TTRD and UmbiliDrill is important to calculate and compare. The pressure loss in the UmbiliDrill system with its small diameter flow lines will have a significant impact on its ability to drill long distances. These values will need be compared to the burst rating of the composite coiled tubing. They will also determine the fluid flow rate, specific gravity and viscosity to ensure the needed fluid flow velocity and turbulence required for cuttings transportation without bursting the pipes. The frictional pressure loss will also affect the ECD of the system. The ECD is very important to keep track of as it determines if the bottom hole pressure stays within the collapse and fracturing pressures when drilling.

7.5.2 Pressure loss and ECD in the TTRD fluid circulation system

The pressure loss in the fluid circulation system for the conventional through tubing drilling method is calculated based on the same parameters as the ones used in the Norne well. The fluid and drill string characteristics are summarized in the tables C.1, C.2, C.3 and C.4. The pressure loss based on these characteristics are calculated in accordance with the equations in section 2.2.1 and the results are summarized with the ECD in the tables C.5, C.6 and C.7.

The maximum horizontal departure based on the burst strength of the drill string while keeping all other input data constant is $L_2 = 12900$ m

7.5.3 Pressure loss and ECD in the UmbiliDrill circulation system

Additional hydraulic calculation methods and assumptions for UmbiliDrill

The hydraulics for UmbiliDrill are calculated differently than for the conventional TTRD. The circulation system for UmbiliDrill is a closed loop system where the drilling fluid is circulated inside two separate flow lines that are imbedded in an umbilical. The supply and return of drilling fluids also have to pass through the entire coil before going into the hole. The coil is assumed to have a fixed length of 6100 m, which is the same as the Anaconda system's coil. This means that there is a total circulation length of 12200 m plus the BHA and BHA annulus length. The total pressure in the umbilical annulus above the upper inflow sub is equal to the fluid column pressure of the static fluid and depends only on the mud weight. The total pressure loss in the circulating system is the sum of the pressure loss in the drilling fluid supply flow line, the drilling fluid return flow line, the BHA and across the bit nozzles.

To evaluate the hydraulic performance of UmbiliDrill flow rates with their respective frictional pressure losses must be known. The ECD contribution from the frictional pressure loss in the return line must be calculated to know that it is possible to stay inside the drilling window. The ECD window and the pressure integrity window of the umbilical must be within the same range

of flow rates. The flow rate must stay within this window to be able to drill safely. When the flow is shut off the static mud will keep the down hole pressures within the drilling window.

The pressure loss in the coil is calculated using sea water and the Darcy-Weisbach (eq. 7.3) equation for frictional pressure loss in turbulent flow. Since the flow is turbulent the friction factor has been found using solving the Colebrook-White equation (eq. 7.4) through iteration.

$$\Delta p = f_D \times \frac{L}{D} \times \frac{\rho u^2}{2} \quad (7.3)$$

$$\frac{1}{\sqrt{f_D}} = -2 \log_{10} \left(\frac{\epsilon}{3.7 D_h} + \frac{2.51}{Re \sqrt{f_D}} \right) \quad (7.4)$$

Δp = pressure loss due to friction (Pa)

f_D = Darcy friction factor

$\frac{L}{D}$ = the ratio of length to diameter of the pipe

ρ = fluid density (kg/m^3)

u = average fluid velocity (m/s)

ϵ = roughness height (m)

D_h = pipe diameter

Re = Reynolds number, $Re = \frac{\rho u D_h}{\mu}$

To get a complete picture of the hydraulics in this system the flow rate was varied from 10 lpm to 400 lpm. The pipe cross-sectional area was used to determine the respective flow velocities and Reynolds numbers. This was used to find the Darcy friction factor and finally the pressure losses with respect to the corresponding flow rates. These pressure losses were compared to the burst and operating pressure of the Fiberspar composite coiled tubing to find the maximum flow rate for a 6100 m coil (12200 m in total).

The ECD was calculated based on the frictional pressure loss in the return line, which is the entire length of the reel of length 6100 m, with a hydrostatic pressure column of the well from sea water with a height of 2900 m. The flow rates were the same as for the total pressure loss.

Results

The results for the pressure loss calculations are summarized in table D.1 and visualized in figure 7.5.

The results for the ECD calculations are shown in table D.2 where the green area shows the drilling window based on a collapse pressure of 1,25 s.g. and a fracturing pressure of 1,68 s.g.. This green window is also shown in table D.1 to show the pressure loss in the entire system when operating at these flow rates. The drilling window is show in figures 7.6 and 7.7.

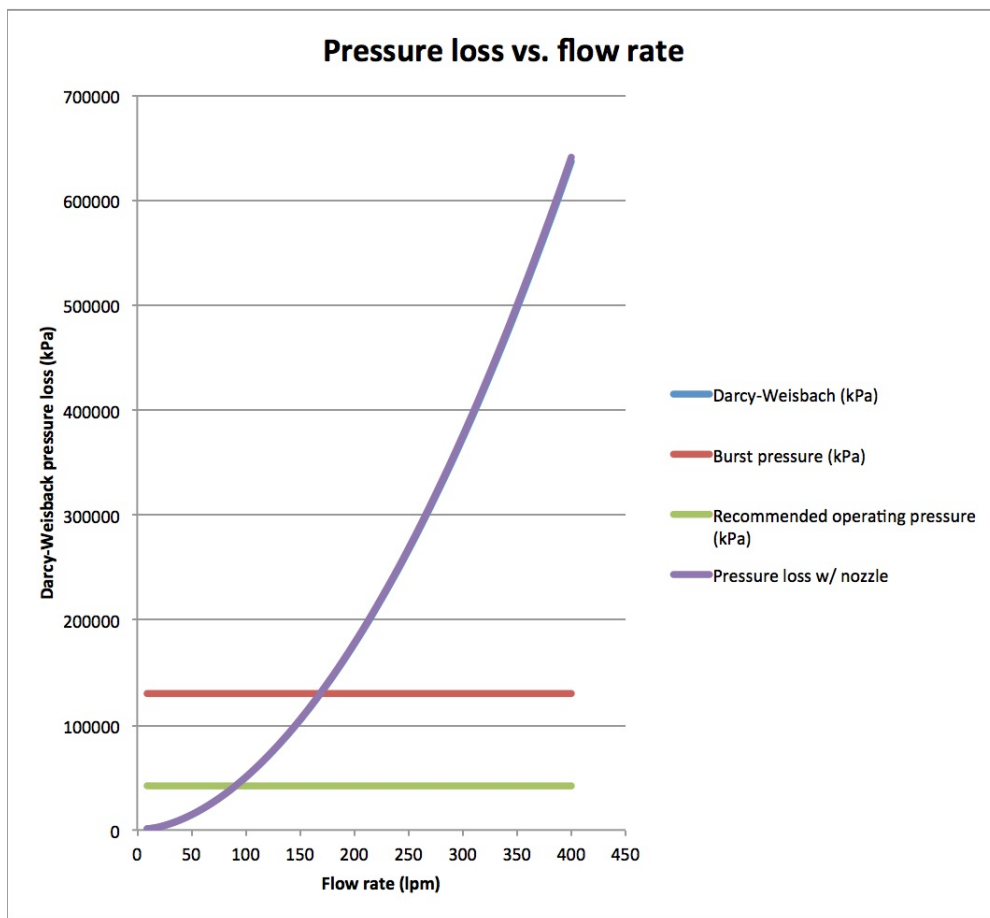

Figure 7.5: Graph showing the frictional pressure loss inside the 12000 m UmbiliDrill circulation system against the flow rate

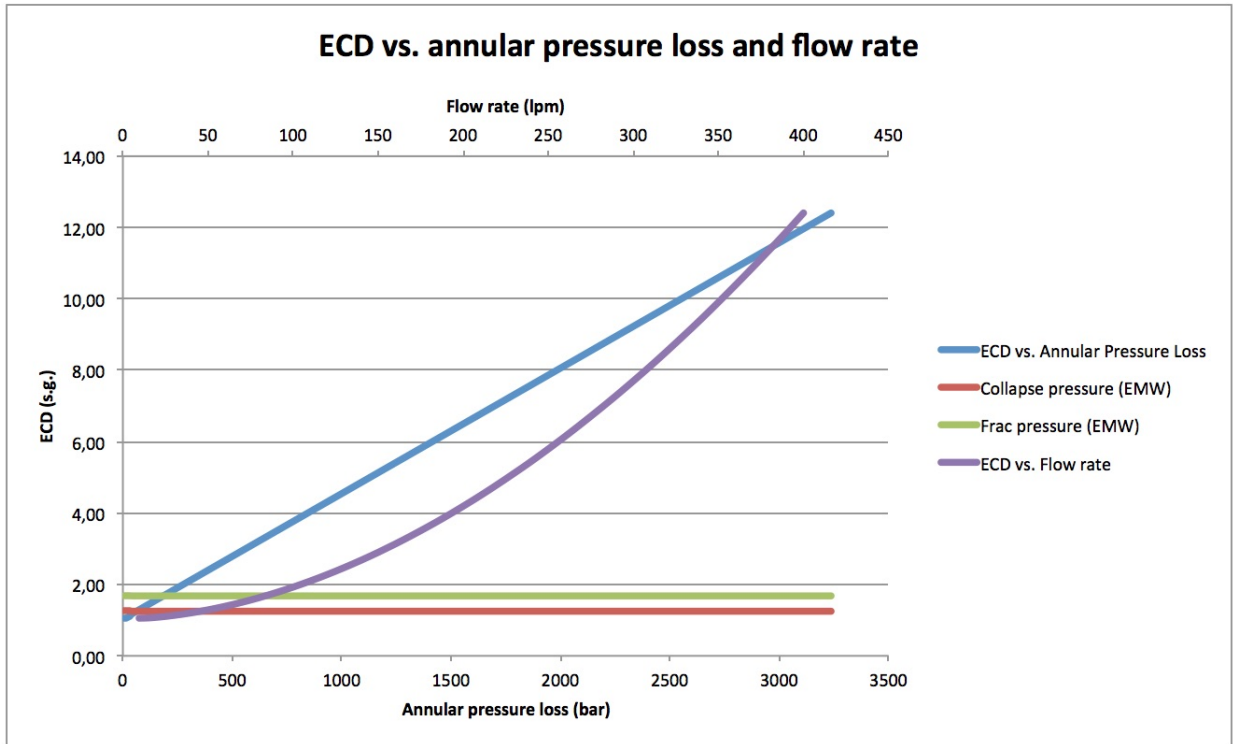

Figure 7.6: Graph showing the ECD for UmbiliDrill where the pressure return flow line functions as the annulus pressure in the ECD equation. 6100 m reel and 2900 m TVD

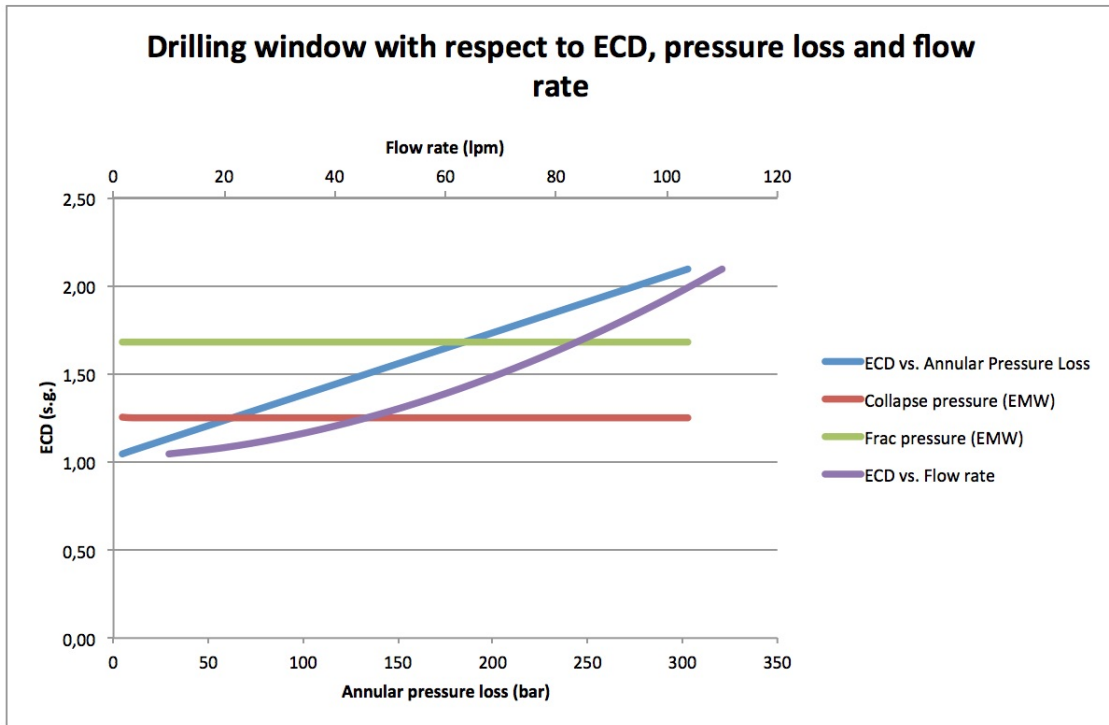

Figure 7.7: Graph showing the drilling window for UmbiliDrill where the pressure return flow line functions as the annulus pressure in the ECD equation. 6100 m reel and 2900 m TVD

7.5.4 Hole cleaning performance for both systems

Both systems have roughly the same BHA diameter and the same open hole diameter. The required flow rate for successful cuttings transport in the BHA interval of both systems will differ due to UmbiliDrill using sea water and TTRD uses a conventional drilling mud. In the simulations done by Statoil when planning this well it was determined that a fluid flow rate of 675 lpm is enough for adequate hole cleaning. This flow rate results in fluid velocities in the drill string annulus and BHA annulus of 1,07 m/s. According to section 2.2.3 the CFR for a 8 1/2" hole and a drilling mud with $PV = 24 \text{ cP}$ and $YP = 16 \text{ lb}/100 \text{ ft}^2$ the $CFR = 445 \text{ gpm} = 1685 \text{ lpm}$. This is equal to a fluid velocity of 0,76 m/s.

Using the same methodology as in section 2.2.3 and inputting the properties for sea water the CFR to UmbiliDrill can be predicted in a 8 1/2" hole and scaled down to a 5 3/4" hole. Assuming a rheology factor of 1, angle factor of 1, a mud weight of 1,03 s.g. and a ROP of 20 m/h results in a flow rate above 500 gpm and close to 600 gmp. 600 gpm in a 8 1/2" hole results in a fluid velocity of 1,03 m/s. It can therefore be assumed that the same fluid velocity is needed in the BHA annulus for UmbiliDrill. This is supported by a experimental study shows that 88 % of a controlled amount of cuttings were transported (CTP%) in a small scale well with a 90 degree inclination using tap water with fluid velocity of 1,01 m/s (Piroozian et al., 2012). A overview of fluid velocities based on the experimental study and the equivalent flow rate required along with cuttings transport percentage can be seen in table 7.5.

Table 7.5: Hole cleaning performance using tap water based on fluid velocities in a 90 degree well from Piroozian et al. (2012). The last row is the CFR from section 2.2.3 based on sea water

CTP%	Fluid velocity (m/s)	Annular area (m^2)	Flow rate (m^3/s)	Flow rate (lpm)
38	0,56	0,0105	0,0059	355
70	0,67	0,0105	0,0071	426
85	0,79	0,0105	0,0083	498
88	1,01	0,0105	0,0106	638
88+	1,03	0,0105	0,0109	652

7.6 Motor estimates for UmbiliDrill

7.6.1 Re-scaling the Nordhard motor size to required size for UmbiliDrill

Assuming that the outer diameter of the stator will be the final outer diameter of the new re-scaled UmbiliDrill motor the following estimates can be made:

Rotor to stator radius ratio = $206/265 = 0,777$

Torque = 400 Nm

Re-scaled stator radius = 3,5" or 88,9 mm

Re-scaled rotor radius = 2,72" or 69,1 mm

Air gap shear stress = 9525 N/m^2

By re-arranging equation 6.11 and inputting the data above the new rescaled active length, L, can be found:

$$L = \frac{T}{\text{Air gap shear stress} \times 2\pi r_{lg}^2} = \frac{400}{9525 \times 2 \times \pi \times 0,0691^2} = 1,40m$$

7.6.2 Motor power requirement estimates

If a Kolibomac inflatable packer tractor is to be considered to be used in the UmbiliDrill system it is necessary to see if the permanent magnet motor has the necessary power to apply the necessary axial force to supply the required weight on bit. The necessary axial force is assumed to be 50000 N. The speed at which the force is applied is assumed to be equal to the rate of penetration, which is 20 m/h or 0,00556 m/s. Power is a function of force times velocity.

$$\text{Power} = \text{Force} \times \text{velocity} = 50000N \times 0,00556m/s = 277W \quad (7.5)$$

The necessary power to inflate the packers with enough pressure to have a no-slip condition is a function of flow rate and pressure. The flow rate of the fluid inside the packer when the packer

is inflated is unknown. The fluid power is beyond the scope of this paper.

Chapter 8

Discussion of the UmbiliDrill system feasibility

8.1 General

The main goal of this thesis is to evaluate the feasibility of UmbiliDrill by:

- Identifying and evaluating the operational impact of UmbiliDrill
- Finding available technologies that can be used to support the UmbiliDrill feasibility and potential
- Evaluate UmbiliDrill with respect to the design and functional requirements that is needed to drill a well

The evaluations of these three points have been presented in chapters 5, 6 and 7. This chapter will discuss the impact of these three points and how they affect the feasibility of UmbiliDrill. This means elaborating on the implication of the supporting technologies, discussing the challenges to the feasibility with respect to the complexity of the system and finally present and discuss the physical limits of the system.

8.2 Supporting technology

The advantages of UmbiliDrill are, based on assumptions of the behavior of the system in a drilling scenario. Therefore there is a high degree of uncertainty in the claims that are made. Rigorous testing of every component in the system is required to be able to give a certain evaluation the the potential and vision of UmbiliDrill.

However, some of the claims mentioned in chapter 5 are supported by the available technologies that are reviewed in chapter 6. Kolibomac was one of the first attempts at drilling without relying on a traditional drill string and rotation by using a down hole tractor. The system was never commercialized, but the testing and groundwork done when it was under development shows that the same is possible for UmbiliDrill. The uncertainty in Kolibomac is the lack of a full scale test of the tractor. The reliability of repeated use of the reinforced inflatable rubber packers is uncertain.

The same can be said for Anaconda. This system is identical to UmbiliDrill in almost every way except for the dual flow line umbilical. The fact that this system was fully functional before the error in the production process of the ACCT was discovered, shows that the elimination of buckling and low drag is possible. Any arguments based on this ability can be regarded as true until the system is tested in a full scale scenario. The tractor that was used in Anaconda, the WWT tractor, is however a product that have been and is currently in use on a commercial level for coiled tubing operations. Since coiled tubing is analogous to UmbiliDrill it can be said with a degree of certainty that using a motor as a hydraulic drill collar is feasible.

The uncertainty in the use of the Fiberspar ACCT for Anaconda and the small diameter composite coiled tubing must also be mentioned. The material properties of these composite tubulars that are used in the calculations involving the UmbiliDrill umbilical serve only as an indication towards the feasibility. The results based on these properties should not be taken literally, but it would have quickly been revealed if the strength of these composite tubulars were to low to be even considered as possible drill string substitutes. The complexity of the umbilical is discussed in more detail in section 8.3.

The potential and benefits the UmbiliDrill system acquires from keeping fluid flow inside the drill string, having MPD capabilities and a closed circulation system can be considered to be true. The benefits of these capabilities are evident in the Reelwell method and the NOV closed circulation system tool. These are technologies that have been successfully tested in full scale scenarios.

The Nordhard drilling machine is currently successfully drilling using a permanent magnet motor to power the entire machine. If the same type of motor can be adapted to UmbiliDrill, there is some evidence that it is possible to drill with an all electrical drive train. However, there is a great deal of uncertainty associated with this and is discussed in more detail in 8.3.

There is still a degree of uncertainty as all of these technologies will have to be able to work together. Anaconda, WWT and Fiberspar already are already designed to work together, but how will the UmbiliDrill umbilical, permanent magnet motor and closed circulation system affect each other and the system as a whole? This is a question that needs to be answered in future development of UmbiliDrill.

8.3 Technical complexity of UmbiliDrill and operational evaluation

8.3.1 General

Many of the technical challenges related to the functioning of the different components of UmbiliDrill is addressed and solved in chapter 6. These were challenges such as how hydraulic drill collar can be successfully used, the possibility of drilling using a composite drill string and how the unique fluid circulation system would work. The technical challenges that are not proven to function to a satisfactory degree in this chapter is the umbilical, the surface equipment and the permanent magnet motor. These components are mentioned, but the technologies that are available will require a high degree of modification for them to fit the requirements of Um-

biliDrill. How these components will function in an operation and a more detailed description of them are discussed below.

On another note, the operational evaluations done in sections 7.2 and 7.3 are preliminary and carry with them a great deal of uncertainty. This is also discussed below.

8.3.2 The umbilical

The available technologies that were reviewed in chapter 6 give clear evidence and viability towards the UmbiliDrill vision introduced in chapter 5. This implies that on their own, these technologies are proven to work, but the challenge lies in adapting them to work together. The best solution would be to base the entire BHA on the Anaconda BHA as this is a technology designed with the same vision as UmbiliDrill. The only difference is the umbilical design. As the Anaconda ACCT is the only component that did not work properly, a new design for the drill string might be a smart move. Although it is important to note that the methods of constructing advanced composite coiled tubing probably have changed since Anaconda was under development. Fiberspar is currently developing an advanced composite coiled tubing called Smartpipe with the same properties as the Anaconda ACCT (Fiberspar).

The umbilical design for UmbiliDill is extremely complex and manufacturing this will be a challenge. Extensive testing will be needed to find how such a design will behave in a drilling scenario. Some important questions to consider are:

- How will the inner flow pipes deform when the umbilical is bent?
- How will the deformation affect the strength of the umbilical?
- The composite material is able to deform without breaking, but how will this affect the electrical and fiber optic lines?
- What process can be use to manufacture a 6100 m continuous umbilical?

Referring to figure 7.1 and imagining the umbilical extending into the into the plane (z-axis) and

the relative orientation of the flow lines are fixed across the x-axis. The x-axis is the horizontal central line and the y-axis is the vertical line. What are the different stress situations when the umbilical is bent along the x-axis compared to the y-axis? Will this have an impact when the umbilical is loaded onto the reel and under transport? Examining the umbilical behavior under stress and deformation is a very important subject for future development of UmbiliDrill.

The fiber optics and electric signal lines embedded in the material surrounding the flow lines are fragile. Especially the fiber optic line. In other designs with electrical lines, the lines are spiraled inside the composite material layers to allow for axial deformation of the composite tubing. This design can utilize the area above and below the flow lines in figure 7.1 to embed the signal lines. They could be embedded in a curving pattern like a sine curve to allow for axial deformation of the surrounding material. This will make the manufacturing process even more complex. This process is beyond the scope of this thesis and will have to be looked into in more detail in the future.

8.3.3 Surface equipment

The surface equipment mentioned previously in this paper has mainly been the reel that holds the umbilical. This reel has been assumed to have identical properties as the Anaconda reel. However as UmbiliDrill uses a umbilical different to the Anaconda a few noteworthy modifications would have to be made. These modifications will have an impact on the complexity of the modifications that have to be made on the rig to accommodate the reel. It will most likely have to be rebuilt in a different size since the umbilical is likely to have different dimensions than the Anaconda ACCT when it is fully developed. The total length of umbilical that the reel can accommodate will most likely be the same as for Anaconda, as this length probably was decided upon through an extensive evaluation maximum length required to reach the largest number of reservoirs on the Norwegian continental shelf.

Another important aspect is the dual flow lines that have to be separated in the centre of the reel. One line has to go to drill fluid processing and the MPD choke systems, while the other

has to go to the pump output line. Due to the small size of these flow line modifications or maybe even a total redesign of a MPD choke system may have to be made. The pumps that are usually capable of generating flow rates of 2500 lpm and above are not suitable for this system. Specially designed pumps that can control the flow rate very sensitively may have to be a part of the surface equipment that have to be hooked up to the drilling rig's own drilling fluid system.

Smaller pumps and volumes allows the use of smaller surface equipment components. Smaller and less heavy components has the potential of using UmbiliDrill on smaller drilling rigs and maybe even drill ships. This will reduce the cost of operation drastically due to high rig rates.

8.3.4 Permanent magnet motor

The permanent magnet motor that is described in section 6.5.3 is currently in use by Nordhard and is able to both power the hydraulics in the tractor, the drill bit and the directional drilling tool. Therefore it can be concluded that it is possible for UmbiliDrill to be powered in the same way. However, there is a great uncertainty in this conclusion that needs to be mentioned. This motor was purpose built for the Nordhard drilling machine and was roughly rescaled to fit the dimensions of the UmbiliDrill BHA. A motor of this size and with the increased down hole temperatures and pressures may behave very differently. Temperature will affect the ability for the motor to cool itself and by consequence the amount of power that the motor can be fed.

Note that there is a concept, called Badger, that claims to be able to drill holes up to 3000m TVD with the purpose being exploration drilling. Badger is a drilling system that drills vertical holes without a drill string by pushing and packing the cuttings behind itself. It buries it self. It uses a tractor principally similar to UmbiliDrill and uses a permanent magnet motor by SmartMotor for power (Kvåle, 2015). It has a average rate of penetration of 2 meters per hour and a power requirement of 10 kW (Badger Explorer ASA, 2007). This is too slow for the effective drilling that is intended for UmbiliDrill and the power output of the motor is likely to be too low. This shows that it is possible to use an all electrical system for offshore drilling, however more development is required.

Moreover, if the performance of the UmbiliDrill motor is assumed to be exactly the same as the Nordhard motor, it will at least be able to supply enough power to move displace UmbiliDrill in the axial directions with enough force for the weight on bit and enough force to pull the string behind it self. This is based on the result of the calculations made in section 7.6.

Also, the performance of the Nordhard motor is similar to many of the drilling motors listed in the drilling data handbook (Gabolde and Nguyen, 2006). Assuming that a permanent magnet motor for UmbiliDrill can achieve the same performance values shows that an electrical solution to eliminate the dependance on string rotation for drilling is feasible.

The use of a permanent magnet motor for drilling must therefore be considered with great uncertainty until a purpose built motor is looked into that can achieve roughly the same output as a established positive displacement motor.

8.3.5 Implications and uncertainty of the operational evaluation

Section 7.2 gives an insight into what the engineers foresaw as potential challenges when planning the Norne multilateral. These challenges are very similar to the criteria against UmbiliDrill, TTRD and CTD are evaluated. The few suggestions made here to potentially relieve some of the risks involved in the operational challenges are therefore directly linked to the UmbiliDrill potential. And as the potential of UmbiliDrill is supported through the reviewed technologies, the suggestions can be regarded to be true within the limits of uncertainty discussed through out this chapter.

This section also reveals that UmbiliDrill will face many of the same challenges as conventional TTRD. There are some areas that will be difficult and challenging regardless of method. Getting stuck in the milled window, for instance, is always a risk when running a string through it.

Referring to section 7.3. All the conventional tools that are usually used during these operations would have to be compatible with the UmbiliDrill BHA. There are also small procedure such as setting wear sleeves as UmbiliDrill is run in hole and retrieving the wear sleeves when

pulling out of hole. Pressure testing using UmbiliDrill may also become an issue as the small inner diameters of the umbilical flow lines sets a limit on the maximum flow rate and maximum allowable pressure. There could also be issues with lifting equipment in and out of hole.

The budgeted time for operations 1 through 10 is twice as high as the budgeted time for operation number 11 (Klaussen and Borlaug, 2009). Therefore any system that can reduce the time spent on preparing a well for sidetracking is beneficial. Assuming that UmbiliDrill can be used as described above, there is a potential to save time by eliminating the wire line rig-up, tripping times, time spent on connections for the operations that require drill pipe and potentially the drilling of the side track. Saving time is an important cost reducing measure due to the high rig rates. The average rig rates at the time of writing this thesis is according to Andersen (2015b) 800 000 USD per day for drilling and completion, including through tubing drilling operation.

8.4 Explanation of results from the case analysis

8.4.1 General drilling performance and limiting factors of conventional TTRD

All of the necessary information, data and simulations required to ensure a safe operation was already available in the drilling program (Klaussen and Borlaug, 2009). But, since the well path was simplified to simplify the necessary calculations for the Umbilidrill feasibility, it required a recalculation of the torque, drag, buckling limit, hydraulic pressure loss, ECD and cuttings transport ability for the conventional TTRD. Efforts were made to make the new well path have almost the same true vertical depth and measured depth. This was done so that any difference in the calculations made in this thesis and in the drilling program would be relatively similar. For instance the predicted ECD values in the drilling program at TD was 1,56 s.g. while the calculated ECD in this thesis ended up being 1,53. The similarities with regard to torque, drag and buckling was not as evident. This is probably mainly due to the difference in the calculation methods. While the engineers designing this well had access to complex computer based simulators, the calculations made in this thesis were done using Microsoft Excel. A complex

computer based simulator could also have been used in this thesis, however the same simulator could not be used when calculating the torque and drag for UmbiliDrill. The methods had to be kept as similar as possible to be able to give a proper comparison.

The results from the calculations made in chapter 7 show, with the well, drill string and BHA data, that it is safe to drill to TD at 4614 m MD. The highest achievable pulling force is lower than the tensile yield strength by a factor of 3. The lowering force is close to the helical buckling force in the beginning of the horizontal section. This would seem to be the limiting factor in this well. The torque in the well with the same bit force and bit torque as in the drilling program is lower than the torsional yield of the string by a factor of 4,7.

The performance of conventional TTRD and UmbiliDrill is compared based on their ability to drill the longest horizontal departure before failing. If the horizontal departure, represented by section L2 in figure 7.2, is increased the limits for the torque, drag and buckling can be found and hence which one is the main limiting factor. These lengths are listed below:

When L2 = 15500 m the torque in the well exceeds the tensile limit of the drill string

When L2 = 24000 m the pulling force without rotation exceeds the tensile limit

When L3 = 3500 m the lowering force without rotation exceeds the buckling limit

The pulling and lowering forces without rotation is used because in a TTD operation rotating the drill string should be kept to a minimum to prevent tubing wear as much as possible.

It is clear that buckling is the main limiting factor. This is expected as the drill string used in TTD operations are less rigid compared to normal. The tubing and open hole size relative to the drill string size is high and will contribute to a lower buckling limit. This result is very important as UmbiliDrill is not limited by buckling.

The frictional pressure loss in the conventional TTRD circulation system is available in the drilling program (Klaussen and Borlaug, 2009) but, had to be re-calculated because the well path was changed. The results show clearly that the hydraulic pressure loss is within the burst strength of the drill string. The final pressure loss is underestimated as the exact inner and outer

diameters of the different components in the BHA were assumed to have the same dimensions as the heavy walled drill pipes for simplicity's sake. The surface circulation systems were also omitted from the calculation. These assumptions have a negligible effect on the safety margin of the operation because of the high burst strength of the drill pipe.

The performance of the conventional TTRD method is evaluated against the same criteria as for the torque, drag and buckling, namely the maximum horizontal departure. The maximum horizontal departure, L₂, based on the burst strength of the drill string alone is estimated to be 12900 m. However, this will also increase the ECD. If the ECD and fracturing pressure of the formation, assuming the fracturing pressure is 1,68 s.g., is taken into consideration, the maximum horizontal departure, L₂, will be 7400 m.

Lowering the flow rate will allow a longer horizontal departure, but eventually the hole cleaning will begin to suffer. For this well with the hole and drill string dimensions and the drilling fluid the recommended flow rate is 675 lpm. This recommendation is based on the simulations carried out in the drilling program. This is also consistent with the API standard for determining the flow rate for adequate hole cleaning. This means that the flow rate cannot be lowered due to hole cleaning and the maximum horizontal departure is determined by the ECD first, then the burst strength.

8.4.2 General drilling performance and limiting factors for UmbiliDrill

The torque, drag and buckling limits for UmbiliDrill was calculated based on the exact same well parameters and with the same methods. First of all, these results shows the benefit of using a composite material with a high strength to weight ratio with respect to the pulling force. The drag is significantly lower in the same well than for conventional TTRD. The maximum pulling force is lower than the tensile strength by a factor of 4,33 compared to 3 for conventional TTRD. The torque is also relatively low, but the torsional strength of the composite coiled tubing by Fiberspar and the Anaconda ACCT is unknown. And since the string is not intended to rotate and it never will be, this result is not relevant to the potential performance of UmbiliDrill.

The lowering force shows that this type of material will buckle already in the vertical section due to the resultant normal forces experienced in the build-up curve. These results clearly show the importance of the down hole tractor functioning properly as a hydraulic drill collar. If the tractor fails it will be impossible to do anything else other than pulling out of hole using the reel. The reel should be designed to be able to pull the drill string out of the hole in case this happens.

The limiting factors for UmbiliDrill are different than for conventional drilling except for the tensile limit. The performance of UmbiliDrill is evaluated against the same criteria as conventional TTRD, which is the maximum horizontal departure, L2. The performance of UmbiliDrill with respect to drag is determined by the ability of the tractor achieve the necessary axial force to pull the umbilical behind itself. The WWT tractor has a maximum output of 14500 lbs or 64,5 kN. This is lower than the tensile strength of the composite material in the umbilical. The limiting factor is no longer dependent on the tensile strength, but rather on the tractor itself. The lifting capacity of the reel according to Phillips et al. (2000) is 366 kN, which is greater than the tractor maximum pulling force and the tensile strength.

The tractor type to be used in the UmbiliDrill system has not yet been decided. The two types are the Kolibomac inflatable packer tractor or the WWT tractor. It was therefore necessary to explore the two possibilities and try to assess which of the two tractor designs are the most optimal. Calculations on the no-slip condition and tensile strength of the reinforcing Aramid fibers in the Kolibomac rubber packers were therefore made. The calculations resulted in the reinforcing fibers failing when the necessary pressure to have a no-slip condition was applied (see tables 7.3 and 7.4). Keep in mind that this pressure does not include the necessary initial pressure to required inflate the packers in the first place. The high pressure required for a no-slip condition is due to the high resultant pressure from the hydrostatic column of the kill mud in the open hole annulus. The Kolibomac packers could not reach the predetermined TD of 4614 m MD or apply enough axial force for the necessary weight on bit. However, this technology is dated and if the packers were re-designed for the purpose of being used in UmbiliDrill, the results may have been different. Increasing the number of reinforcing fibers would be a start. For instance doubling the number to 300 will allow the packer to reach 4614 m MD. How this would affect the behavior of the packer is not known and would have to be studied.

Clearly the best tractor design for UmbiliDrill based on the axial force output is the WWT tractor. If this tractor was used and the reel was able to accommodate an infinitely long umbilical the maximum horizontal departure, L_2 , is 10500 m. If the tractor had an infinite axial output and the limit is the tensile strength of the umbilical, L_2 could be 64000 m before the composite material fails.

The hydraulic performance of UmbiliDrill had to be calculated differently because it was assumed that it required seawater as a drilling fluid which is a newtonian fluid. The results from the hydraulic calculations also cannot say anything about the maximum horizontal departure as this is already determined by the size of the reel. These results simply determine if the proposed circulation system for UmbiliDrill is feasible or not. The feasibility is determined by the hydraulic performance fulfilling these three criteria:

- Keeping the ECD below the fracturing pressure of the formation with a flow rate necessary for adequate hole cleaning
- Keeping the frictional pressure loss below the burst strength of the umbilical with a flow rate necessary for adequate hole cleaning

The necessary flow rate for adequate hole cleaning has to equate to an annular fluid velocity of about 1 m/s. In the Norne well the open hole was 5 3/4" with an assumed BHA diameter of 3.5". This results in a flow rate of 650 lpm and above according to the API standard and simulations by Statoil in the drilling program. This flow rate is too high for the UmbiliDrill umbilical to handle (see table D.1). The umbilical will burst at 170 lpm and the ECD will be high enough to fracture the formation at 90 lpm. With the current assumptions for the BHA and open hole dimensions UmbiliDrill cannot be used to drill the well described in chapter 7.

There are, however, a few options available to make sure UmbiliDrill can be used. The first option is to design an optimized drilling fluid that can successfully transport cuttings at lower annular fluid velocities. This will require extensive testing and serves as an important area of future study. A second option is to make the reel shorter to lower the ECD. This impairs the total possible drilling length and will result in the system not being able to reach TD and is not

recommended. Increasing the size of the inner flow lines is a third option. This will result in a bigger reel as the total diameter of the umbilical will have to be increased to accommodate the new flow lines. A bigger reel can be problematic due to spacing and lifting issues. The size of the UmbiliDrill reel is imagined to be the same as for the Anaconda system as this is a proven technology and can have a high chance of working for UmbiliDrill as well. The umbilical could retain its original size by reducing the size of the supply flow line to 0,75" ID while increasing the return flow line to 1,5" ID. This, however, results in a drastic increase in the frictional pressure loss beyond the burst strength at the same flow rates. The last and most viable option is to lower the open hole size to lower the flow area in the BHA annulus. A possible bit size found in the DDH (Gabolde and Nguyen, 2006) is 3 3/4". With this bit and hole size, annular fluid velocities of around 1 m/s are achievable at flow rates of about 60 lpm. Having the optimal flowrate of 60 lpm will give some room for varying the flow up to 80 lpm before high ECD becomes an issue. The same effect could be accomplished by increasing the BHA size until the flow area in the annulus is small enough for a flow velocity of 1 m/s at 60 lpm.

8.4.3 Drilling performance evaluation

The maximum horizontal departure has been used to evaluate the performance between the two methods to have a common variable between them. Of course if the goal of this well was to drill an extended reach well with an extreme horizontal departure it would have been designed accordingly. All possible measures would have been taken to ensure that the buckling limit would be as high as possible. However, most drilling operations in general are not carried out to drill as far as possible, but rather to drill a well into a reservoir at a specific orientation and length with a hole size that can accommodate a profitable production rate. The Norne well was designed according to these criteria in the drilling program and most TTD operations carried out by Statoil have similar hole sizes and therefore must have similar in-place completion sizes (see section 3.4). It is therefore interesting to find the limiting factor in operations with these typical dimensions for the drill string and well. Conventional TTRD will not be able to access reservoirs that lie outside the range decided by the limiting factor while other methods that are

not limited in the same way might be able to. This is an important point as the goal of TTD operations is to access reservoirs that were previously inaccessible, or too expensive to develop, and produce them through an existing well to save cost.

The same arguments can be made for the hydraulics as for the torque, drag and buckling when it comes to using the horizontal departure to evaluate the performance. If an extended horizontal departure was the goal of this operation the circulation system would have been designed accordingly. However, the maximum horizontal departure sets a clear goal for UmbiliDrill. As one of the visions for UmbiliDrill is to access reservoirs that were previously inaccessible it will have to at least perform as well as conventional methods. The horizontal departure gives a more accurate picture of the hydraulic performance as the frictional pressure loss, ECD and hole cleaning is dependent only on the total measured depth and true vertical depth, not the complexity of the well path.

The arguments above are important when considering the potential performance of UmbiliDrill. It will have to meet the same demands as conventional methods when it comes to drilling a well that can accommodate a profitable production rate. UmbiliDrill will have no problems of reaching the same targets as conventional drilling, assuming the target can be reached with a 6100 m drill string, based on the drag and the tractor output. However it cannot at this stage meet the same criteria when it comes to the hole size. As stated in chapter 4, the hole size decided based on the necessary production rate. Reducing the bit and hole size of UmbiliDrill will set a limit on the types of reservoirs it can be used in as the most common hole sizes for through tubing drilling today on the NCS is $5\frac{3}{4}$ " to $5\frac{7}{8}$ ". The other option of increasing the BHA size to ensure hole cleaning is not recommended because it will increase the risk of damaging the in-place completion and increase the risk of getting stuck in the milled window.

There is also the issue of the pore pressure and fracturing pressure used in the calculations are based on the specific formations encountered in the Norne well. These pressures will vary from well to well. Based on the calculations in table D.2, the fracturing pressure cannot be lower than 1,39 s.g. as this equivalent to the ECD at 60 lpm. Of course the drilling fluid is in this case assumed to be sea water with a density of 1,03 s.g.. Using a drilling fluid with a lower density is

possible, but the flow rate needed for hole cleaning will increase. It will also be more expensive as it probably will not be as abundant as seawater. Seawater also has the benefit of not being environmentally harmful assuming no influx of harmful fluids during drilling. It should also be noted that the small interval for safe flow rates will require extra sensitive down hole pressure gauges and extra sensitive pumps.

Based on the hydraulic performance the UmbiliDrill system is feasible, but only within this particular well design (see table 7.1 and figure 7.2) with the readjusted open hole of 3 3/4". Figures showing the minimum flow rate required for hole cleaning and maximum flow rate with respect to the ECD and total pressure loss can be seen in figures 8.1 and 8.2. The vertical lines represent the flow rate limit. The flow rate must be kept to the right of these limits at all times, but cannot exceed the limit where ECD crosses the fracturing gradient or when the pressure loss crosses the burst limit. Changing any of the parameters will yield different results.

To properly evaluate the physical limits and the hydraulic performance of UmbiliDrill, input parameters of the calculations have to be varied over a wide range. For instance the hydraulic performance must be explored by using different types of drill fluids, hole depths, hole lengths and umbilical dimensions. A computer program could be written to calculate the same results as in tables B.3, B.4, D.1 and D.2. The program could then vary the relevant input data as in tables 7.1, B.1, B.2, C.1, C.2, C.3 and C.4 and compare the results to predefined limits. The program could then print the results that fall within the limits and identify the input parameters. This would build a database that can be used to find the most optimal input values for, for example, the umbilical dimensions.

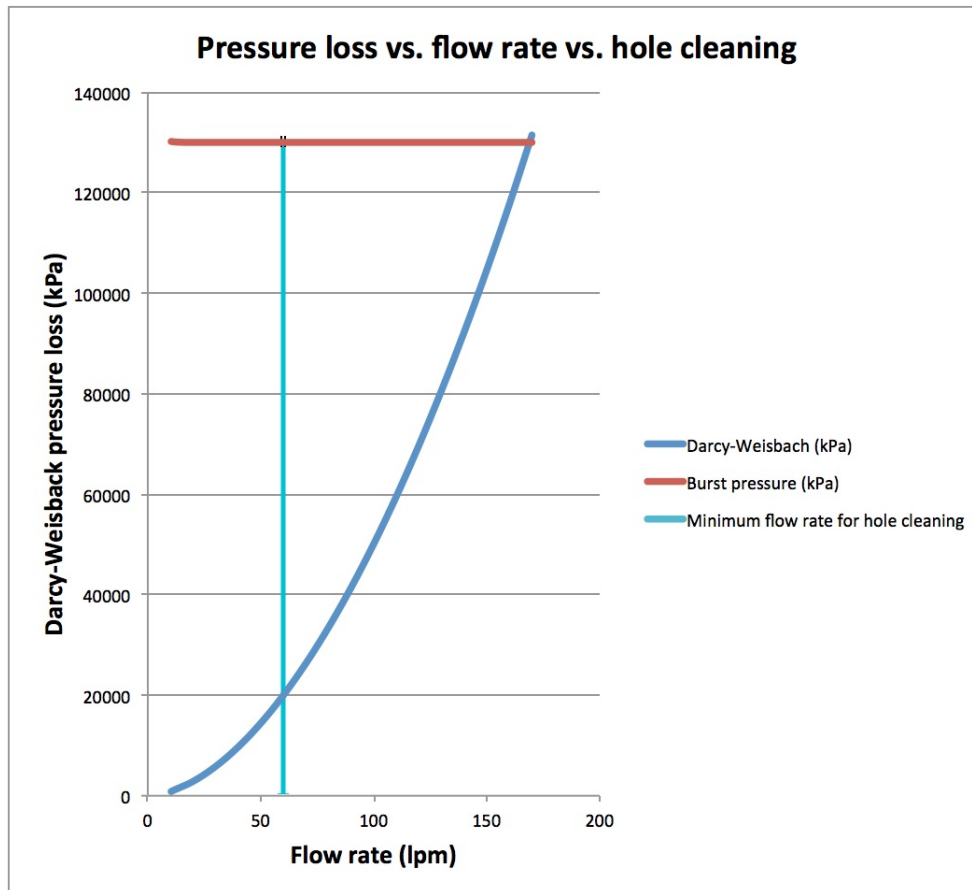

Figure 8.1: Graph showing the frictional pressure loss inside the 12000 m UmbiliDrill circulation system against the flow rate and minimum flow rate for hole cleaning

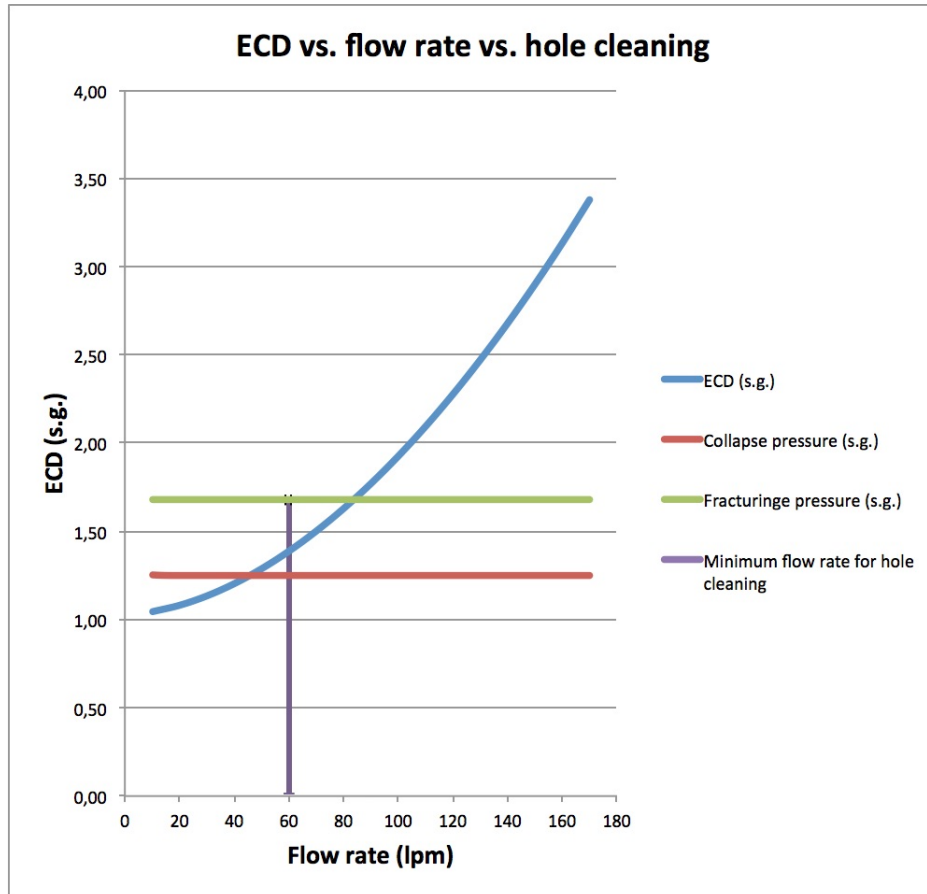

Figure 8.2: Graph showing the drilling window for UmbiliDrill where the pressure return flow line functions as the annulus pressure in the ECD equation. 6100 m reel and 2900 m TVD. With hole cleaning flow rate

Chapter 9

Summary and conclusions

The main goal of this thesis is to build a foundation for a feasibility study of a concept called UmbiliDrill. UmbiliDrill is an all electrical drilling system that is independent of traditional rotating jointed pipe by using a down hole tractor as a hydraulic drill collar and an electrical motor that is connected to the surface by a spoolable composite umbilical with dual-flow lines for the circulation system and instrumentation with high speed data transfer capabilities (see figure 5.1). The system is intended at this stage for through tubing drilling operations to effectively drill through tubing laterals into bypassed reservoirs or into different parts of mature reservoirs to stimulate production. The vision for UmbiliDrill is to perform this more safely and cost effectively than the conventional methods in use today. The feasibility is addressed through the following points:

- Identifying and evaluating the operational impact of UmbiliDrill
- Finding available technologies that can be used to support the UmbiliDrill feasibility and potential
- Evaluate UmbiliDrill with respect to the design and functional requirements that is needed to drill a well

9.1 Summary of results and limitations

The key features of UmbiliDrill along with the corresponding enabling system component and supporting technology that are discussed throughout this thesis are summarized in figure 9.1. These features form the basis of the evaluation of the operational impact UmbiliDrill can have. The functional requirements of UmbiliDrill along with the results from the case analysis and their implications are summarized in figure 9.2.

The limitations to the results summarized in figure 9.1 are related to the uncertainty gained from preliminary evaluations based on technologies known to work on their own, but not as part of a complete drilling system like UmbiliDrill.

The results summarized in figure 9.2 are limited to the assumptions and parameters defined in this thesis. The main assumptions and parameters are the two dimensional wellpath, sea water used as circulation fluid, the BHA and open hole dimensions and the drilling window.

Component	Feature	Potential	Supporting technology
Composite material for the umbilical	High strength to weight ratio	Allows drilling of more difficult well paths	Anaconda advanced composite coiled tubing by Fiberspar Composite coiled tubing by Fiberspar
	High buoyancy	Increases safety Allow for the elimination of rotation as an aid while drilling and tripping	
	High fatigue limit	Fiberspar claims 5000 fatigue cycles and above compared to steel coiled tubing that can only handle 63	
Fiber optics and electrical signal lines	Precise directional control	Allows for effective wells that can react immediately to any formation anomalies and can drill into the reservoir more accurately, which yields higher production rates	Anaconda advanced composite coiled tubing by Fiberspar
	Precise logging measurements		
	Real time weight monitoring	Real time weight measurements makes sure the umbilical always is in tension	SmartPipe by Fiberspar
	Precise WOB and vibration monitoring	WOB and vibration monitoring maximises bit life, which reduces time spent on tripping	
	Distributed sensing	Fiber optics used to monitor temperature, acoustics, strain and compression data throughout the entire string	See Appendix E
Tractor functioning as a hydraulic drill collar	Elimination of buckling	Buckling will not be a limiting factor when planning a well. Allows wells to be drilled beyond the point of lockup for conventional strings	Anaconda Kolibomac
	Provide weight on bit, take up reaction forces from drilling, assist during tripping	The tractor will provide all the necessary functions that are usually done by the drill string. This eliminates the need for a rigid pipe and pipe handling systems	Western Well Tools
Permanent magnet motor	Rotates the bit independent of the string	Eliminates the need for a rotating string which drastically reduces tubing wear	Nordhard Hard Rock Drilling
	All electrical system	Down hole components can be operated independent of flow and hydraulic pressure. Hydraulically operated components can be powered by electric motor.	SmartMotor Badger
Dual flow line circulation system	Managed pressure drilling capability	Excellent ECD management with continuous circulation for enhanced hole cleaning and bore hole stability.	The Reelwell Drilling Method NOV Closed Circulation System Device
	Static kill mud in umbilical annulus with hydraulic pressure control		
	Continuous circulation system	Lowers risk for stuck pipe Enables drilling through narrow pressure windows	
		Reduces risk of damaging the reservoir Immediate kick detection	

Figure 9.1: A summary of the key features of UmbiliDrill with the corresponding components, potential and supporting technology

	Requirement	Results	Implications
Torque	Torque must be absorbed by the tractor	Assumed to make the requirement	Torque can be eliminated as a limiting factor assuming the tractor can handle it.
Drag	Lower than tensile strength and tractor output	46 kN drag with a tensile strength of 185 kN and tractor output of 64,5 kN	The tractor will be the limiting factor and must be able to handle the drag generated by the necessary well path.
Buckling	Tractor must keep the umbilical in tension	Composite umbilical is very likely to buckle unless kept in tension by tractor	Buckling is eliminated as a limiting factor.
Hole cleaning	Annular fluid flow velocity must be at least 1 m/s	ECD and frictional pressure exceed their limits with a 3,5" BHA and 5 3/4" open hole.	The relative BHA and hole size must create an annulus that allows annular flow velocities of 1 m/s or higher with safe flow rates
Flow rate	Flow rates must not burst the flow lines or make the ECD exceed the fracturing pressure	Safe flow rate interval with respect to burst pressure is 0 to 160. Safe flow rate interval with respect to the ECD and the assumed drilling window is 50 - 80 lpm	The drilling window will define the safe flow rate interval within the burst limit. The flow rates are dictated by the ECD and drilling window with a minimum flowrate dictated by the hole cleaning requirement
Tractor output	Must be able to handle the reaction forces from drilling	Kolibomac tractor: The reinforcing cords will fail due to the high pressure required for no-slip condition	Rubber packers must be redesigned to meet the requirements of UmbiliDrill
		WWT Tractor: Maximum tractor output is higher than the maximum drag. Can apply as much weight on bit as the conventional method	Can be considered safe to use as the tractor in UmbiliDrill

*The results are based on applying UmbiliDrill in a through tubing multilateral well case on Norne by Statoil

Figure 9.2: A summary of the fulfillment of the functional and design requirements required of UmbiliDrill to drill a well

9.2 Main conclusions

The different features of UmbiliDrill and its corresponding benefits have the potential of lowering the risk of some HSE elements, complete certain operational tasks as effectively as conventional methods, or in some cases more effectively, and construct a well with a higher potential production rate than conventional methods.

UmbiliDrill will be less abrasive to the in-place completion due to the system not requiring rotation of the drill string to rotate the bit. Upholding the structural integrity of the in-place completion is an utmost priority in a through tubing drilling operation. Damaging the in-place completion can lead to a series of events that have direct HSE consequences such as a burst tubing, failed down hole safety valve or a leaking XMT. Replacing this equipment is not only costly, but carry with them their own potential risks. UmbiliDrill has the potential of lowering this risk and makes it more safe and thereby more cost effective as a through tubing drilling system compared to conventional methods.

By a comparison to the Anaconda system and the capabilities of coiled tubing systems using the WWT tractor it is possible to evaluate how UmbiliDrill will fit into the sequence of preparations for the through tubing drilling operation and the drilling of the lateral. It has the potential to accomplish what conventional methods does in two runs requiring both wire line and drill pipe in a single run. It can trip in and out of the hole at higher speeds than jointed pipe as no time is spent on connections. Surge and swab effects are also lowered due to UmbiliDrills managed pressure drilling capabilities and continuous circulation system. The Anaconda system has the ability to mill the sidetrack using a oriented whipstock and UmbiliDrill should be able to do the same. This gives further indication towards the feasibility of UmbiliDrill in as a through tubing drilling system.

Drilling into depleted mature reservoirs requires a high degree of down hole pressure control. It also requires precise directional control to effectively steer the well into a position in the reservoir that yields the most optimal conditions for production. The high-speed data transfer due to the electrical signal lines and fiber optic lines, the LWD and Measurement While Drilling (MWD)

equipment can in real time update the position of UmbiliDrill allowing precise adjustments and quick reactions to any formation anomalies. The same system can actively monitor the down hole pressure to keep it within the drilling window at all times. The MPD capabilities and continuous circulation system allows safe drilling through narrow and difficult drilling windows without damaging the formation. Immediate kick detection is another benefit of the UmbiliDrill circulation system. These features make UmbiliDrill an improved system for drilling into difficult bypassed and mature reservoirs.

The arguments above are supported by technologies that can serve as the UmbiliDrill building blocks. Each building block and its features have corresponding technologies that confirm their potential benefits.

The high strength to weight ratio, buoyancy and fatigue limit and their benefits of the composite umbilical have been proven by Fiberspar in their involvement with the Anaconda system. The dual flow line circulation system is similar to the Reelwell method circulation system. The benefits of this type of circulation system have been tested and proven during the development of Reelwell. However, there is an uncertainty in this argument as the umbilical design is new and the exact behavior cannot be predicted.

The tractor is a fully functioning technology from Western Well Tools successfully used to drill both with Anaconda and regular coiled tubing.

The permanent magnet motor is currently in use by Nordhard Hard Rock Drilling to drill pipelines in mountains for hydropower. The same technology is used in a concept called Badger that claims to be able to drill to depths of 3000 m TVD. It can be argued that the same type of motor is possible for UmbiliDrill, but will require further development.

The benefits of high speed data transfer of MWD and LWD is evident in the Anaconda system. These technologies can be used as a foundation for the development of UmbiliDrill and they provide support to the feasibility of UmbiliDrill.

The design and functional requirements to drill a well was evaluated in a case study of a through

tubing multilateral well on Norne by Statoil. These requirements are that the drilling system must be able to handle the frictional forces and reactive forces from tripping and drilling respectively. It must be able to provide enough down hole pressure to keep the hole from collapsing while allowing a circulation rate that satisfies the requirement for hole cleaning without creating an ECD that fractures the formation or bursts the drill string.

The results from this case study revealed that the umbilical can be used to drill this well as the maximum drag was below the yield strength of the composite material. The maximum tractor output of the WWT tractor was higher than the maximum drag and could apply as much weight on bit as the conventional system showing that it is capable of being used to drill this well. The Kolibomac tractor reinforced rubber packers could not be used as the reinforcing cords will fail due to the pressure required for a no-slip condition between the packer and the bore hole wall.

The main limitation to the system is the umbilical. The small inner diameters of the fluid flow lines creates an ECD and frictional pressure that exceed their limits at a flow rate necessary to satisfy the hole cleaning requirements. For the hole cleaning requirements to be met an annular flow area that can accommodate fluid flow velocities about 1 m/s at flow rates ranging between 50 - 80 lpm is required. This flow rate must also keep the ECD within the drilling window and the frictional pressure loss lower than the burst strength. This limitation, however, does not disprove the feasibility of the system as reducing the hole size will allow this to occur.

These results show that UmbiliDrill can drill the same well as conventional methods. Since it is not limited by buckling and can always supply enough torque and weight on bit, it can drill further and with a more complex well path. The limit is based on the maximum length of umbilical allowed on the reel and the limitation of the ECD and hole cleaning requirement.

The feasibility study conducted in this thesis has revealed that UmbiliDrill has the potential to meet the demands of less costly drilling operations and increased recovery of oil and gas. There were discovered a few limitations to the drilling performance and uncertainty of certain features of the system, however there are no show stoppers. Based on this, further development of the system is recommended.

9.3 Recommendation for future work

Reducing the hole size to make an annulus flow area that can accommodate fluid velocities that satisfy the hole cleaning requirement at safe flow rates makes UmbiliDrill fulfill the functional and design requirements for drilling a well. While lowering the hole size fixes the issue it will limit UmbiliDrill's ability to drill wells with the required hole size to accommodate the necessary completion for a profitable production rate.

Creating an annulus flow area that satisfies the hole cleaning requirement at a safe flow rate also can be achieved by increasing the BHA size to accommodate the hole size. This will increase the risk of damaging the in-place completion and getting stuck in the milled window.

Therefore further development of the umbilical is of importance. Other umbilical dimensions, inner flow line diameters, length, composite material types and drilling fluid properties have to be explored and tested to find an optimal umbilical design that can handle the same hydraulic stress as a conventional drill string.

UmbiliDrill describes that the return fluid intake port in the BHA can manipulate the return flow to the annulus and opening both fluid flow lines in the umbilical for input flow. The effect this has on the hole cleaning limitation has not been explored in this thesis. Calculating the fluid hydraulics for all possible flow paths with respect to hole cleaning, ECD and frictional pressure loss is recommended to fully understand how the unique circulation system will behave.

The UmbiliDrill system is envisaged to be an all-electrical drilling system. For this to be possible a motor must be able to power both the tractor and the drilling assembly. This will require a power output as high as the Nordhard motor by SmartMotor. The Nordhard motor can be used as a foundation for further development as the requirements for a motor to drill tunnels for hydropower in mountains are different to the requirements for drilling oil and gas wells. Development to ensure that a motor with a sufficient power output to power the tractor and drilling assembly despite high pressures and temperatures is essential. The motor must also be dimensioned to fit into the BHA of UmbiliDrill.

Of the two tractors discussed in this thesis the Kolibomac tractor is the only one being powered electrically. The WWT tractor is powered hydraulically with the circulating fluid and will not fit into the vision of an all-electrical drilling system. The thesis revealed that the Kolibomac tractor could not be used in this system. Therefore a tractor with the same capabilities as the WWT tractor that can be powered by electrical motors or by electrically powered hydraulic pumps is necessary.

Other areas of use for this system can be explored. Exploring the necessary steps for this system to be used on light intervention vessels can make it ideal for applications such as through tubing slim hole drilling if a well needs to be completed beforehand due to a difficult pressure scheme in the reservoir, pilot holes in exploration drilling to find shallow gas as no risers are needed or perform certain well intervention tasks.

List of Figures

- 1.1 TTD Visualization 3

- 2.1 3D Dogleg 12
- 2.2 Buckling 13
- 2.3 Hole Cleaning Charts 20

- 5.1 UmbiliDrill Schematic 36
- 5.2 Crossover Design 38

- 6.1 Kolibomac System 49
- 6.2 Kolibomac Drill Collar 51
- 6.3 Kolibomac Packer Assembly 52
- 6.4 Friction forces vector 54
- 6.5 Friction forces on same axis 54
- 6.6 Rod analogy 55

6.7	Packer under stress	56
6.8	Anaconda BHA	61
6.9	Anaconda Tractor	61
6.10	Reelwell Method	66
6.11	Nordhard Tractor Schematic	70
6.12	Photos of Nordhard Tractor	71
7.1	Umbilical design	84
7.2	T and D well path	85
7.3	T and D results for TTRD	87
7.4	T and D results UmbiliDrill	88
7.5	Pressure loss vs Flow rate	94
7.6	ECD vs annular pressure and flow rate	95
7.7	ECD drilling window	95
8.1	Pressure loss vs Flow rate vs Hole cleaning	114
8.2	ECD drilling window and hole cleaning flow rate	115
9.1	Features and potential of UmbiliDrill	118
9.2	Design and functional requirements	119

List of Tables

2.1	Angle factors for deviated holes Luo et al. (1994)	19
6.1	Anaconda ACCT data (Statoil, 2000)	59
6.2	WWT Coiled Tubing Tractor specifications	60
6.3	Performance properties comparison between composite CT and steel CT (Rispler et al., 1998)	62
6.4	Nordhard permanent magnet motor specifications (Kvåle, 2015)	69
7.1	Torque and drag well data	85
7.2	Input factors for no-slip condition of Kolibomac inflatable packers	90
7.3	Minimum internal packer pressure required for no-slip condition	90
7.4	Tensile stress experienced by the reinforcing Aramid fiber cords in inflatable packer	91
7.5	Hole cleaning performance using tap water based on fluid velocities in a 90 degree well from Piroozian et al. (2012). The last row is the CFR from section 2.2.3 based on sea water	96

A.1	Through tubing drilling drill string data	137
A.2	Through tubing drilling BHA data	138
A.3	Effect of rotation on torque and drag	138
A.4	Drag calculation results for TTRD	138
A.5	Torque calculation results for TTRD	139
B.1	Umbilical data	140
B.2	UmbiliDrill BHA data	140
B.3	Drag calculation results for UmbiliDrill	141
B.4	Torque calculation results for UmbiliDrill	141
C.1	Hydraulics Well Characteristics	142
C.2	Hydraulics String Characteristics	142
C.3	Hydraulics BHA Characteristics	143
C.4	Fluid Characteristics	143
C.5	Contribution to the specific gravity of the annulus fluid from cuttings	143
C.6	Constant pressure losses independent of horizontal hole length	143
C.7	Variable pressure loss when varying the horizontal hole length	143
D.1	UmbiliDrill pressure loss calculation result based on a 6000 m reel with 12000 m circulation length due to dual flow lines	145

D.2 ECD calculation results with for UmbiliDrill 146

Acronyms

ACCT Advanced Composite Coiled Tubing.

BHA Bottom Hole Assembly.

BOP Blow Out Preventor.

CITHP Closed in Tubing Head Pressure.

CT TTD Coiled Tubing Through Tubing Drilling.

CTD Coiled Tubing Drilling.

DDH Drilling Data Handbook.

DLS Dogleg Severity.

ECD Equivalent Circulating Density.

GOR Gas Oil Ratio.

HSE Health, Safety and Environment.

ITC Internal Tree Cap.

KOP Kick Off Point.

LWD Logging While Drilling.

MD Measured Depth.

MFC Multi fingered Caliper.

MPD Managed Pressure Drilling.

MWD Measurement While Drilling.

NCS Norwegian Continental Shelf.

OBM Oil Based Mud.

OGC Oil Gas Contact.

OWC Oil Water Contact.

OWTCT Open Water Tree Cap Tool.

POOH Pulling Out of Hole.

RIH Run In Hole.

ROP Rate of Penetration.

RPM Rotation Per Minute.

TD Target Depth.

THCP Tubing Hanger Crown Plug.

THNP Tubing Hanger Nipple Protector.

TTD Through Tubing Drilling.

TTML Through Tubing Multilateral.

TTRD Through Tubing Rotary Drilling.

UBD Underbalanced Drilling.

UKCS United Kingdom Continental Shelf.

WL wireline.

WOB Weight On Bit.

WOR Work Over Riser.

WWT Western Well Tools.

XMT Christmas Tree.

Bibliography

Aadnøy, B. S., Fazelizadeh, M., and Hareland, G. (2010). A 3d analytical model for wellbore friction. *Journal of Canadian Petroleum Technology*.

Allanic, C. (2012). Overview of optical distributed sensing for reservoir monitoring in total e&p. *Society of Petroleum Engineers*.

Andersen, S. K. (2015a). Through tubing drilling and completion (ttdc) in statoil. Internal Document, Statoil Drilling and Well ENG DCI WIE.

Andersen, S. K. (2015b). Through tubing drilling discussion with advisor for slimhole drilling tpd dw eng dci well interventions, statoil. Personal Communication.

API (FIFTH EDITION, JUNE 2006). Api recommended practice 13d rheology and hydraulics of oil-well drilling fluids. Standard by the American Petroleum Institute.

Badger Explorer ASA (2007). Technical details. Retrieved June 4, 2015 from <http://www.bxpl.com/?id=897>.

Bawaked, W. K., Beheiri, F. I., and Saudi, M. M. (2008). A new record of coiled tubing reach in open hole horizontal wells using tractor and friction reducer in saudi arabia history: A case study. *Society of Petroleum Engineers*.

Belayneh, M. (2006). *Review of Buckling models in oil well*. Shaker Verlag, University of Stavanger.

Burke, J., Eller, G., Venhaus, D., and Gantt, L. (2014). Coiled tubing drilling: Increasing horizontal reach in the kuparuk field. *Society of Petroleum Engineers*.

- Cannon, R. and Aminzadeh, F. (2013). Distributed acoustic sensing: State of the art. *Society of Petroleum Engineers*.
- Fiberspar. Fiberspar production development. Retrieved June 02, 2015 from <http://fiberspar.wccclient.com/development/smartpipe.html>.
- Flateboe, R. E. (1999). Analyses of the stress situation in the formation when introducing a well tractor. Master's thesis, University of Stavanger.
- Gabolde, G. and Nguyen, J.-P. (2006). *Drilling Data Handbook*. IFP Publications, Editions Technip, eighth edition edition.
- Hansen, H. (2014). The umbilidril methodology for drilling long reach wellbores to drain marginal reservoirs. Internal Document.
- Hansen, H. (2015). Discussion with umbilidril inventor and supervisor. Personal Communication.
- Haughom, S. (2014). Drilling device and method for using the same. EP Patent App. EP20,130,781,335.
- Haughom, S. and Knutsen, K. (2011). Rock drilling machine. WO Patent App. PCT/NO2010/000,358.
- Klaussen, K.-G. and Borlaug, T. (2009). Drilling & completion programme ttml well 6608/10-e-1 y2h. Internal Document from Statoil.
- Kvåle, L. O. A. (2015). Sales manager marine / project manager of smartmotor. Personal Correspondence.
- Lenhart, R. A. (1994). Coiled-tubing drilling: A directional service company point of view. *Society of Petroleum Engineers*.
- Luo, Y., Bern, P., Chambers, B., and Kellingray, D. (1994). Simple charts to determine hole cleaning requirements in deviated wells. *Society of Petroleum Engineers*.

- Marker, R., Haukvik, J., Terry, J. B., Paulk, M. D., Coats, E. A., Wilson, T., Estep, J., Farabee, M., Berning, S. A., and Song, H. (2000). Anaconda: Joint development project leads to digitally controlled composite coiled tubing drilling system. *SPE/ICoTA Coiled Tubing Roundtable, Houston*.
- Moen, T. (1995). *Utvikling og Testing av Foringsmodul for Utstøpning av et Konsentrisk rør i et Borehull for Systemet Kolibomac*. PhD thesis, University of Stavanger.
- Nas, S. and Laird, A. (2001). Designing underbalanced thru tubing drilling operations. *Society of Petroleum Engineers*.
- National Oilwell Varco (2014). Continuous circulating system. Retrieved May 28, 2015 from https://www.nov.com/Segments/Rig_Systems/Offshore/Drilling_Pressure_Control/Continuous_Circulation_Systems/CCS-9-5k_Continuous_Circulation_System.aspx.
- Nordhard (2014a). Hovedegenskaper. Retrieved May 27, 2015, from <http://www.norhard.no/index.cfm?id=159802>.
- Nordhard (2014b). Nd700hr - norhard directional 700mm hard rock. Retrieved May 27, 2015 from <http://www.norhard.no/index.cfm?id=183212>.
- Nordhard (2014c). Produkter/boring. Retrieved May 27, 2015 from <http://www.norhard.no/index.cfm?id=159798>.
- Phillips, I. C., Paulk, M. D., , and Constant, A. (2000). Real real-time geosteering. *Society of Petroleum Engineers*.
- Piroozian, A., Ismail, I., ZulkefliYaacob, Babakhani, P., and Ismail, A. I. (2012). Impact of drilling fluid viscosity, velocity and hole inclination on cuttings transport in horizontal and highly deviated wells. *Journal of Petroleum Exploration and Production Technology*.
- Pourjavad, M. (1993). *Investigation of Inflatable Packer Technology for Oil Industry Applications Based on Aramid Fiber Reinforced Rubber*. PhD thesis, University of Stavanger.

- Rajabi, M. M., Nergaard, A., Hole, O., and Vestavik, O. (2010). Riserless reelwell drilling method to address many deepwater drilling challenges. *Society of Petroleum Engineers*.
- Rispler, K., Berning, S., and Fowler, H. (1998). Composite coiled tubing in harsh completion/workover environments. *Society of Petroleum Engineers*.
- Robotic Drilling Systems AS. Technology. Retrieved June 10, 2015 from <http://www.rds.no/technology>.
- Skaugen, E. (2013). Friction in curved wells. Unpublished paper, University of Stavanger.
- Society of Petroleum Engineers (2014). Coiled tubing drilling. Retrieved March 27, 2015 from http://petrowiki.org/Coiled_tubing_drilling.
- Statoil (2000). Anaconda drilling system. Unpublished presentation by Statoil.
- Statoil (2007). Boring gjennom produksjonsrør. Retrieved 21 April 2015 from <http://www.statoil.com/no/technologyinnovation/optimizingreservoirrecovery/advanceddrilling/through%20tubing%20drilling/pages/throughtubingdrilling.aspx>.
- Statoil (2014). Statoil opens new research centre – a milestone for improved oil recovery. Retrieved June 07, 2015 from <http://www.statoil.com/en/NewsAndMedia/News/2014/Pages/IORJune2014.aspx>.
- Vestavik, O. M., Brown, S. C., and Kerr, S. P. (2009). Reelwell drilling method. *Society of Petroleum Engineers doi:10.2118/119491-MS*.
- WWT International Inc. Case studies. Retrieved June 4, 2015 from http://wwtinternational.com/index.php/case_studies/.

Appendix A

Conventional Through Tubing Rotary Drilling Torque and Drag Tables

Table A.1: Through tubing drilling drill string data

Drill string data data	
OD (m)	0,0889
ID (m)	0,0661
Modulus of elasticity (kPa)	210000000
Density (s.g.)	7,85
Mass per length (kg/m)	26,17
Buoyancy factor, β	0,82
Buoyant weight, W_s (kN/m)	0,210
Moment of inertia, I (m^4)	$2,129 \times 10^{-6}$
Annular clearance for L1, r (m)	0,03175
Annular clearance for L2, r (m)	0,02858

Table A.2: Through tubing drilling BHA data

BHA data	
OD (m)	0,0889
ID (m)	0,0524
Modulus of elasticity (kPa)	210000000
Density (s.g.)	7,85
Mass per length (kg/m)	37,7
Buoyancy factor, β	0,82
Buoyant weight, W_s (kN/m)	0,302
Moment of inertia, I (m^4)	$2,696 \times 10^{-6}$
Annular clearance for L3, r (m)	0,02858

Table A.3: Effect of rotation on torque and drag

Rotational contribution	With rotation	No rotation
Block speed, V_h (m/s)	0,2	0,2
Rotational speed, N_r (rpm)	120	0
Pipe radius, r (m)	0,04445	0,04445
Angle of resultant velocity, Ψ (radians)	0,006	$\frac{\pi}{2}$

Table A.4: Drag calculation results for TTRD

Hole Section	Vertical depth (m)	Measured depth (m)	With rotation		No rotation		Static, F (kN)
			Pull, F (kN)	Lower, F (kN)	Pull, F (kN)	Lower, F (kN)	
Top of well	0,0	0,0	608,3	607,6	681,9	534,0	607,9
Kick off point	2000,0	2000,0	189,0	188,3	262,6	114,7	188,7
End of build-up	2900,0	3413,7	0,3	-0,3	54,0	-54,0	0,0
BHA	2900	4413,7	0,1	-0,1	12,1	-12,1	0,0
Bit	2900	4613,7	0,0	0,0	0,0	0,0	0,0

Table A.5: Torque calculation results for TTRD

Hole section	Measured depth (m)	Static weight, bit off bottom (kN)	Torque, off bottom (kNm)	Static weight, with bit force (kN)	Torque, in string (kNm)	Torque, in well (kNm)
Top of well	0,0	607,0	5,0	517,9	3,8	11,7
Kick off point	2000	188,7	5,0	98,7	3,8	11,7
End of build-up	3413,7	0,0	2,4	-90,0	2,4	10,3
BHA	4413,7	0,0	0,5	-90,0	0,5	8,4
Bit	4613,7	0,0	0,0	-90,0	0,0	7,9

Appendix B

UmbiliDrill Torque and Drag Tables

Table B.1: Umbilical data

Umbilical data	
OD (m)	0,078
ID (m)	0,051
Modulus of elasticity (kPa)	20400000
Density (s.g.)	1,76
Mass per length (kg/m)	4,63
Tensile yield (kN)	185
Buoyancy factor, β	0,18
Buoyant weight, W_s (kN/m)	0,00826
Moment of inertia, I m^4	$1,49 \times 10^{-6}$
Annular clearance for L1, r (m)	0,0372
Annular clearance for L2, r (m)	0,034025

Table B.2: UmbiliDrill BHA data

Umbilical data	
OD (m)	0,0889
ID (m)	0,0524
Modulus of elasticity (kPa)	20400000
Density (s.g.)	7,85
Mass per length (kg/m)	37,7
Buoyancy factor, β	0,82
Buoyant weight, W_s (kN/m)	0,302
Moment of inertia, I m^4	$2,696 \times 10^{-6}$
Annular clearance for L3, r (m)	0,028575

Table B.3: Drag calculation results for UmbiliDrill

Hole Section	Vertical Depth (m)	Measured Depth (m)	Pull, F (kN)	Lower, F (kN)	Static, F (kN)
Top of well	0,0	0,0	42,7	5,1	23,9
Kick off point	2000	2000	26,2	-11,4	7,4
End of build-up	2900	3413,7	13,7	-13,7	0,0
BHA	2900	4413,7	12,1	-12,1	0,0
Bit	2900	4613,7	0,0	0,0	0,0

Table B.4: Torque calculation results for UmbiliDrill

Hole Section	Measured Depth (m)	Static weight, bit off bottom (kNm)	Torque, off bottom (kNm)	Static weight, with bit force (kNm)	Torque, in string (kNm)	Torque, in well (kNm)
Top of well	0,0	23,9	0,7	18,9	0,6	7,3
Kick off point	2000	7,4	0,7	2,4	0,6	7,3
End of build-up	3413,7	0,0	0,6	-5,0	0,6	7,3
BHA	4413,7	0,0	0,5	-5,0	0,5	7,2
Bit	4613,7	0,0	0,0	-5,0	0,0	6,7

Appendix C

Conventional Through Tubing Rotary Drilling Hydraulics Tables

Table C.1: Hydraulics Well Characteristics

Well characteristics	
Open hole size (in)	5,75
Tubing inside diameter (in)	6
True vertical depth (m)	2900
Measured depth (m)	4614
Bit nozzle area (in^2)	0,1243
Tubing length (m)	2000
Build up radius (m)	900
Build up length (m)	1414
BHA length (m)	200
Horizontal open hole length (m)	1000

Table C.2: Hydraulics String Characteristics

String characteristics	
String inside diameter, D (in)	2,6
Annulus outside diameter, D_o (in)	5,75
Annulus inside diameter (outside string), D_i (in)	3,5
Length, L (m)	4414
Burst strength (kPa)	191100

Table C.3: Hydraulics BHA Characteristics

BHA characteristics	
String inside diameter, D (in)	2,06
Annulus outside diameter, D_o	5,75
Annulus inside diameter (outside string), D_i	3,5
Length, L (m)	200

Table C.4: Fluid Characteristics

Fluid characteristics	
Fluid specific gravity, d (kg/l)	1,44
Fluid flow rate, Q (lpm)	625
Plastic viscosity, μ_p (cP)	24
Rate of penetration, A_v (m/h)	20
Rate of fall of cuttings, V_s (m/min)	10

Table C.5: Contribution to the specific gravity of the annulus fluid from cuttings

Specific gravity contribution from cuttings	
BHA annular specific gravity (kg/l)	1,451
Open hole annular specific gravity (kg/l)	1,451
Tubing annular specific gravity (kg/l)	1,453

Table C.6: Constant pressure losses independent of horizontal hole length

Constant pressure losses independent of horizontal hole length	
Pressure drop in bit nozzles (kPa)	13631
Pressure drop in drill string from top to end of build up (kPa)	10511
Pressure drop in BHA (kPa)	1883
Pressure in BHA annulus (kPa)	124
Pressure drop in drill string annulus in build up (kPa)	878
Pressure drop in drill string annulus from top to KOP (kPa)	864
Total constant pressure loss in system (kPa)	27890

Table C.7: Variable pressure loss when varying the horizontal hole length

Variable pressure loss when varying horizontal hole length	
Pressure drop in horizontal drill string	3080
Pressure drop in horizontal drill string annulus	621
Total pressure loss in system	31591
Total annular pressure loss	2487
Equivalent circulation density (s.g.)	1,53

Appendix D

UmbiliDrill Hydraulics Tables

Table D.1: UmbiliDrill pressure loss calculation result based on a 6000 m reel with 12000 m circulation length due to dual flow lines

Flow rate	Flow rate m ³ /s	Pipe area A	Flow velocity v	Reynolds number Re	Relative pipe roughness e/D	Friction factor fD (from Colebrook-White)	Pressure loss Darcy-Weisbach (kPa)	Burst pressure (kPa)	Operating pressure (kPa)	Pressure loss w/ nozzle
10	0,00017	0,000506707	0,33	8605	9,84E-05	0,032	850	130000	42000	852
20	0,00033	0,000506707	0,66	17210	9,84E-05	0,027	2849	130000	42000	2859
30	0,00050	0,000506707	0,99	25816	9,84E-05	0,025	5823	130000	42000	5846
40	0,00067	0,000506707	1,32	34421	9,84E-05	0,023	9700	130000	42000	9739
50	0,00083	0,000506707	1,64	43026	9,84E-05	0,022	14432	130000	42000	14494
60	0,00100	0,000506707	1,97	51631	9,84E-05	0,021	19995	130000	42000	20085
70	0,00117	0,000506707	2,30	60237	9,84E-05	0,020	26364	130000	42000	26487
80	0,00133	0,000506707	2,63	68842	9,84E-05	0,020	33508	130000	42000	33668
90	0,00150	0,000506707	2,96	77447	9,84E-05	0,019	41428	130000	42000	41630
100	0,00167	0,000506707	3,29	86052	9,84E-05	0,019	50119	130000	42000	50369
110	0,00183	0,000506707	3,62	94658	9,84E-05	0,019	59561	130000	42000	59863
120	0,00200	0,000506707	3,95	103263	9,84E-05	0,018	69746	130000	42000	70105
130	0,00217	0,000506707	4,28	111868	9,84E-05	0,018	80653	130000	42000	81075
140	0,00233	0,000506707	4,60	120473	9,84E-05	0,018	92249	130000	42000	92738
150	0,00250	0,000506707	4,93	129078	9,84E-05	0,018	104595	130000	42000	105157
160	0,00267	0,000506707	5,26	137684	9,84E-05	0,017	117658	130000	42000	118297
170	0,00283	0,000506707	5,59	146289	9,84E-05	0,017	131456	130000	42000	132177
180	0,00300	0,000506707	5,92	154894	9,84E-05	0,017	145926	130000	42000	146735

Table D.2: ECD calculation results with for UmbiliDrill

Flow rate (lpm)	Pressure in return line (bar)	ECD (s.g)	Collapse pressure (EMW)	Frac pressure (EMW)
10	4	1,05	1,25	1,68
20	14	1,08	1,25	1,68
30	30	1,13	1,25	1,68
40	49	1,20	1,25	1,68
50	73	1,29	1,25	1,68
60	102	1,39	1,25	1,68
70	134	1,50	1,25	1,68
80	170	1,63	1,25	1,68
90	211	1,77	1,25	1,68
100	255	1,93	1,25	1,68
110	303	2,09	1,25	1,68
120	355	2,28	1,25	1,68
130	410	2,47	1,25	1,68
140	469	2,68	1,25	1,68
150	532	2,90	1,25	1,68
160	598	3,13	1,25	1,68
170	668	3,38	1,25	1,68
180	742	3,64	1,25	1,68

Appendix E

Fiber optic distributed sensing

Distributed sensing technology is a technology that allows for continuous distributed measurement along a fiber optic cable. Measurements such as strain, compression, acoustics and temperature can be monitored along the entire length of the fiber optic cable. These measurements have numerous applications in the petroleum industry. Currently fiber optic lines are used for real time signal transmission from down hole pressure and temperature gauges (Cannon and Aminzadeh, 2013).

The current proven applications for distributed sensing technology are near well-bore hydraulic fracture stimulation surveillance, flow profiling, well integrity monitoring, vertical seismic profiling, gas-lift optimization, sand detection and electrical submersible pump (ESP) monitoring (Cannon and Aminzadeh, 2013). These applications are primarily intended for completed wells or pipeline monitoring. However, since the potential of optical fiber technology has probably not yet been fully explored (Allanic, 2012), there could be distributed sensing technology application for drilling systems in the future.