



FACULTY OF SCIENCE AND TECHNOLOGY

MASTER THESIS

Study programme:
Industrial Economics

The spring semester, 2022

Open

Authors:
Felix Lossius Husum
Martinus Kirkefjord Leirvaag

Supervisor(s): Idriss El-Thaljii

Thesis title: A Multi-Criteria Classification Framework for Spare Parts Management

Credits (ECTS): 30

Keywords:
Spare Part Classification
Criticality Analysis
Multi-Criteria Inventory Classification
Analytic Hierarchy Process

Pages: 72
+ appendix: 82

Stavanger, 15.06/2022
date/year



A Multi-Criteria Classification Framework for Spare Parts Management: A case study

Felix Lossius Husum
Martinus Kirkefjord Leirvaag

Master's Thesis in Industrial Economics
Date: June 2022
Supervisor: Idriss El-Thaljii, University of Stavanger
Advisor: Jawad Raza, Moreld Apply AS

Faculty of Science and Technology
Department of Security, Economics and Planning

Abstract

The offshore petroleum industry can be described as a capital-intensive industry. Capital intensive refers to a heavy and high-value asset structure with long lifetimes that demands considerable effort to maintain. Large investments are required to produce goods and services, and the consequences of downtime, shortage and production loss are extensive. Efficient and reliable maintenance operations are essential to secure safe, productive and reliable production, creating a great incentive to stock up on all kinds of spare parts to reduce the consequences of the above-mentioned. However, there are great costs and inefficiencies related to spare parts inventories. Holding costs are high, turnover ratios are low, and inconsistent demand patterns make demand difficult to predict. Therefore, the trade-off between availability and efficiency is a fundamental principle in inventory management of spare parts.

The industry puts a lot of effort into optimising spare parts inventories and spends resources on developing efficient and reliable spare parts operations. Among these efforts is spare parts classification. This is the process of classifying spare parts into distinct groups and is crucial to control the enormous number of parts with different characteristics. The decisions on which characteristics to use in classification practices is not straightforward and has been subject to research and debate for many decades.

In current classification practices, most spare parts of an equipment are assigned the same criticality rank as the equipment itself, which is not necessarily the case. Therefore, Moreld Apply AS are interested in developing a method for spare parts classification that further evaluates criticality and consequence analysis on a spare parts level. This study presents a way to classify spare parts using a multi-criteria framework to establish precise criticality classes for each part.

The findings in this thesis have ultimately led to the conclusion that multi-criteria approaches have great potential in the classification practices in the industry. We also see that the framework is already implementable for single case scenarios, such as the one analysed in this thesis, and provide reliable results. The results indicate that, in almost all instances, the criticality level of spares is reduced compared to the main equipment.

The main contributions of this thesis is a framework with several steps guiding the user through the process of setting up the evaluation, preparing the analysis, as well as doing the analysis. Important aspects will be the selection of the most appropriate classification criteria, data collection processes and preparation activities. These topics form the main body of research.

Acknowledgements

We would like to thank our internal supervisor at the University of Stavanger, Idriss El-Thalji, for sharing his knowledge and expertise. His guidance was deeply appreciated, and aided us very much.

Additionally, we want to thank Moreld Apply AS, specifically business manager Jawad Raza, for providing a solid and interesting research question for the thesis. We would also like to extend our gratitude to other Moreld Apply employees for giving valuable insight and guidance.

Abbreviations

MRP	Material Requirement Planning
ERP	Enterprise Resource Planning
DM	Decision-Maker
CMMS	Computerised Maintenance Management System
SKU	Stock Keeping unit
FSN	Fast-moving, Slow-moving, Non-moving
MCIC	Multi-Criteria Inventory Classification
MADM	Multi-Attribute Decision Making
MASTA	Multi-Attribute Spare Tree Analysis
CAD	Computer-Aided Design
PO	Purchase Order
WO	Work Order
PCM	Pairwise Comparison Matrix
AHP	Analytic Hierarchy Process
VED	Vital, Essential, Desirable
CI	Consistency Index
CR	Consistency Ratio
PM	Preventive Maintenance
PdM	Predictive Maintenance
P&ID	Piping and Instrumentation Diagram
BOM	Bill of Materials
NCS	Norwegian Continental Shelf
RCM	Reliability Centred Maintenance
PDT	Planned Delivery Time
CPDT	Controlled Planned Delivery Time
IMP	Inventory Management Policy
OM	Operations Management
JIT	Just in Time
O&G	Oil & Gas
O&M	Operations and Maintenance
RAMS	Reliability, Availability, Maintainability, Supportability
OEM	Original Equipment Manufacturer
PCM	Pairwise Comparison Matrix

Contents

1	Introduction	1
1.1	Background and Motivation	2
1.2	Case study	3
1.3	Problem	6
1.4	Objective and Scope	7
1.5	Delimitation	7
1.6	Project Workflow	8
1.7	Outline of Thesis	9
2	Literature Review	10
2.1	Maintenance Management in the Oil and Gas Industry	10
2.2	Norsok Z-008	11
2.2.1	Maintenance Management	12
2.2.2	Technical Hierarchy	12
2.2.3	Consequence Classification	13
2.3	Spare Parts Management	13
2.3.1	Spare Parts Demand Drivers	14
2.3.2	Spare Part Criticality and Control Characteristics	15
2.4	Spare Part Classification	17
2.4.1	Spare Part Classification Models	19
2.4.2	MADM - Multi-Attribute Decision Making	22
2.4.3	AHP - Analytic Hierarchy Process	23
2.4.4	MASTA - Multi-Attribute Selection Spare Tree Analysis	24
3	Methodology	26
3.1	Overview of Analysis and Framework Procedure	26
3.1.1	System Analysis	27
3.1.2	Criteria Selection and Classification	29
3.1.3	Criteria Evaluation	31
3.1.4	Criteria Ranking and Prioritisation	32
3.1.5	Decision Diagram	37
3.1.6	Classify Spares Into Groups	38
3.1.7	Inventory Management Policy Matrix	39
3.2	Research Design	39
3.3	Validity	40

4	Analysis and Framework Development	41
4.1	System Analysis	41
4.2	Criteria Selection and Criticality Definition	42
4.3	Criteria and Attribute Evaluation	44
4.4	Analytic Hierarchy Process	45
4.5	Decision Tree	49
4.6	Classify Spare Parts Into Groups	50
4.7	Inventory Management Policy Matrix	52
4.8	Case Study	53
4.8.1	Systems Analysis	54
4.8.2	VED Classification	55
4.8.3	AHP for Logistics Characteristics	55
4.8.4	Decision Diagram for Overall Criticality Classification	56
5	Discussion	58
5.1	Framework Performance and Applicability	58
5.1.1	Reliability and validity of results	59
5.1.2	Data Validity	61
5.2	Model Features and their impacts	63
5.2.1	Perspectives and Criticality Definition	63
5.2.2	Multi-criteria vs. Single-Criterion	63
5.2.3	Criteria Selection	64
5.2.4	Complexity vs. Simplicity	65
5.2.5	Degree of Nuance in Classes	65
5.2.6	Main shortcomings	66
5.3	Other practicalities and implications	67
5.3.1	Customisation vs. standardisation	67
5.3.2	When and where to use	68
6	Conclusion	70
6.1	Recommendation	70
6.2	Limitations and Future Work	71
	Bibliography	73
	Appendix	76
A	Case studies	76
A.1	DC Electric Motor	76

CONTENTS

A.2	Gate valve	78
B	Overview of Classification Process	80
C	Decision tree from classification framework	81
D	AHP Rating Scale	82

1 Introduction

Our thesis is inspired by Moreld Apply AS, a service provider in the offshore oil and gas market delivering operations and maintenance services. Their client base consists of several oil and gas actors on the Norwegian Continental Shelf (NCS), which will provide the basis for the thesis case study. These clients act as operators of offshore installations, an environment where efficient and reliable maintenance operations are essential to secure safe, productive and reliable production. Therefore, there is a need to ensure high availability of spare parts for maintenance work. Some of these parts are highly critical to assure safety and production up-time, but inventory management involves considerable costs. This forms the basis of spare parts management, a management field where availability and efficiency are an everlasting conflict.

A central part of spare parts management is spare parts classification. This is the process of classifying spare parts into distinct groups based on their similarities in characteristics. However, deciding on which characteristics to use in classification practices is not straightforward and has been subject to research and debate for many decades. Some spare part characteristics focus on financial aspects, whereas others focus on material movement patterns, lead times and turnover rates. Most maintenance practitioners will emphasise the need to define an equipment criticality level. Criticality is a somewhat vague term as it all depends on the perspective of the assessors. An item of high cost might be considered critical for the economist, being constrained and measured against the maintenance budget. In contrast, the supply chain manager might consider an item with long lead times and high replenishment risk more critical. This lays the foundation for different classification models.

Typical classification tools are ABC and FSN-analysis (Fast-moving, Slow-moving and Non-moving). ABC focus on annual usage value, a product of the annual spare part consumption and price. FSN emphasise the material movements of the spare parts. Both methods have been widely used across industries because of their simplicity, and apply mainly one criterion for classification. Modern research on classification methods finds this to be too simplistic for the complex realities of spare parts operations. It is suggested to implement several classification criteria to cover all variabilities. That is, it is desired to incorporate additional spare parts characteristics in the same classification framework. This forms the field of multi-criteria inventory classification (MCIC), a subfield of multi-attribute decision-making (MADM) models which focus on spare parts classification and inventory management. These models combine the best of several classification models and offer opportunities in terms of improved classification, eventually resulting in optimised and efficient spare parts operations. For that reason, there is an interest in developing and testing an MCIC-framework for multi-attribute spare parts classification. The development of the classification framework, its effectiveness and validity will be studied in this thesis.

1.1 Background and Motivation

The offshore oil and gas industry is characterised by complex operations, heavy and expensive machinery, and high consequences of failure, pushing industrial engineering to its limits. The investment costs are high, and the consequences of downtime, shortage and production loss are extensive. In addition, for offshore oil and gas, the repercussions of failure also pose a significant level of risk in terms of health, safety and environment (HSE). With offshore installations comes hazardous environments where accidents might cause great danger to human health and safety, and the potential consequences of oil spills and gas leaks create a strong emphasis on risk management and proactive maintenance. In addition, governmental institutions impose strict laws and policies to prevent such failures, requiring the offshore actors to put great efforts into maintenance management and engineering. Therefore, the industry has since its dawn focused on developing reliable, safe and robust operations, efficient supply chains, and cost-efficient maintenance management.

To prevent failure, breakdowns and downtime, maintenance activities must be planned. There are several established approaches and programmes on the topic, each developed to cover its own specific needs. However, independent of the chosen maintenance program(s), one always desires to find the most cost-efficient methods of doing maintenance work. That is, we want to ensure that the operations are running smoothly, but also to make sure that the cost of maintenance is at a reasonable level. At the most extreme, there is no need to fix a machine if the cost of fixing it exceeds the gains of having it fixed. And this problem boils down to the well-known and fundamental optimisation problem in logistics and operational planning; the cost of storage versus the cost of shortage. This logic applies to inventory management in general, but for maintenance purposes, we are most interested in the inventory levels of spare parts. How many spares do we need to keep in stock, where should they be stocked, and what is the cost of running short?

In general, a desire is to minimise inventory levels as much as possible, reducing waste, costs and inefficiencies related to storage. However, as mentioned above, the offshore oil and gas industry is characterised by a high cost of lost production, essentially meaning a high cost of shortage, assuming that not having the item in stock when needed might cause a breakdown of crucial machinery, ultimately resulting in costly production loss. The shortage cost increases dramatically as we account for HSE factors as well. This creates a great incentive to stock up on all kinds of spare parts to ensure that production downtime and failures are less probable. Nevertheless, studies have revealed that great inefficiencies in spare parts inventories exist. Holding costs are high, turnover ratios are low, and the level of non-moving and obsolete items is significant. In fact, studies provided by Gopalakrishnan and Banerji (2013), indicates that about 40% of the working capital in the process, mining and transport industries is tied to the spare part inventory. Among them, 25% is often related to non-moving or obsolete items. Furthermore, their studies also show that about 60 - 80% of the total maintenance

costs in most industries are accounted for by spare parts consumption. Such issues have caused the industry to put a great deal of effort into optimising their spare parts inventories, and resources are being spent on developing efficient and reliable spare parts operations. Among these efforts is spare parts classification.

1.2 Case study

Moreld Apply AS is a multi-disciplinary engineering company delivering maintenance management products and services for its clients. A central part of these solutions is their spare parts management and evaluation tools and services, which, in short, support every aspect of the customers’ spare parts operations. This includes, among other things, risk and criticality analysis, spare parts classification, spare parts evaluation and spare part inventory optimisation. The overall goal is to provide the customers with a fully integrated spare parts solution for optimal operations, maintenance and control. As previously mentioned, their client base consists of oil and gas operators.

The case study covers oil and gas operators controlling and operating several offshore production facilities on the NCS. Data used for the thesis is gathered from three specific offshore installations, one offshore storage location, and one onshore warehouse. In addition to offshore and onshore storage locations, each production facility holds its own spare parts inventories. The total number of spare parts in terms of SKUs (Stock Keeping Units) is vast. For a typical offshore installation mentioned above, the total number of spare parts is about 50k SKUs.

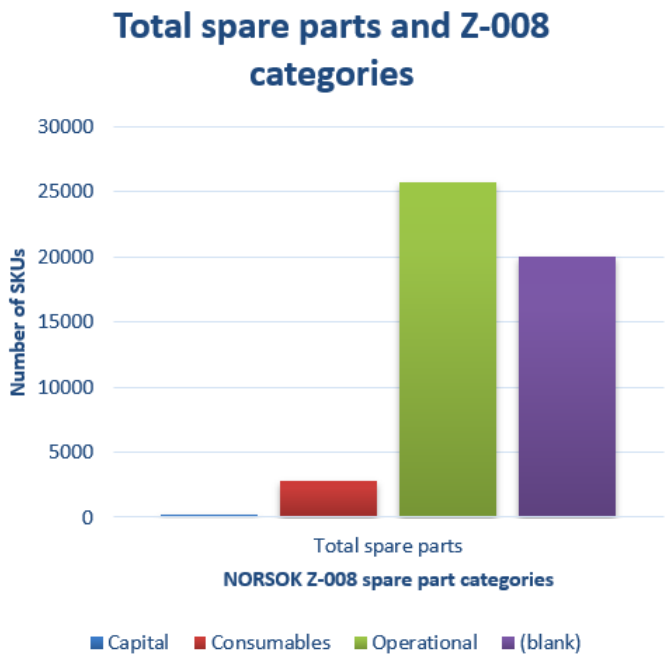

Figure 1: Total spare parts volumes categorised based on NORSOK Z-008 spare parts categories

Amongst them, about 50% are categorised as “Operational spare parts” (See section 2.4 on NORSOK

Z-008 spare parts categories), accounting for about 45% of total spare parts value in terms of SKU unit prices. “Capital spare parts” account for about 0.50%, or about 250 SKUs, of total spare parts SKU. However, often being more expensive items, the capital spares account for impressively 35 - 40% of total spare parts value in terms of unit prices. About 6% of spare parts volumes are categorised as “consumable spare parts, ” accounting for about 0.40% of total spare parts value. The remaining ca. 40% is marked as “blank”, which may have several potential causes, the main reasons being either (1) items are not part of the project scope (in which forms the case study data) as the respective spares might have been classified earlier in other projects, or simply not to be classified, (2) the spare parts might not have been evaluated yet, or (3) these are new items, not properly analysed, or parts that are currently undergoing some kind of change. Moreover, about 45% of the provided data is not marked with unit prices. This may affect the actual price ratios provided above.

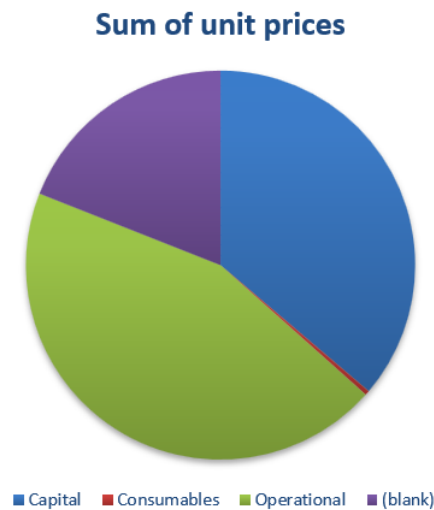

Figure 2: Total spare parts value in terms of SKU unit prices based on spare parts categories

Furthermore, the average vendor delivery lead time for spare parts categories is as follows: capital spare parts; 84 days, operational spare parts; 39 days, and consumables; 21 days. These numbers are only to be viewed as indicators of the lead time situations, as this parameter, in reality, is subject to significant variability, depending on the specific spare part cases, as well as the risks and uncertainties that follow with supply chain management. The standard deviation of the above numbers is 115.5 days, 42.9 days and 12.2 days, respectively. At the extremes, there are cases with delivery lead times of 420 days, as well as cases with lead times of only two days.

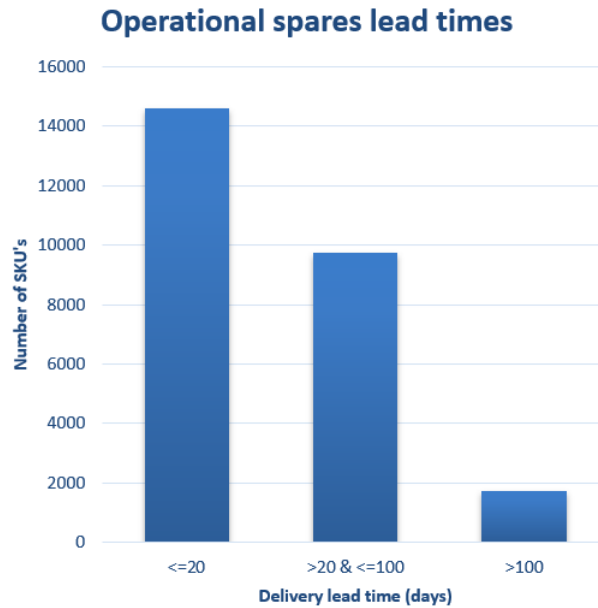

Figure 3: Distribution of vendor delivery times for operational spare parts

Moreover, of all spare part SKUs, about 50% highlight equipment with the highest criticality levels. That is, equipment which is classified as either highly critical for production or that is categorised as barrier/safety-critical. This means that the respective spare parts are a part of, or are meant to fix/replace, equipment deemed highly critical. Figure 4 illustrates the distribution of spare part SKUs based on “parent equipment” criticality levels.

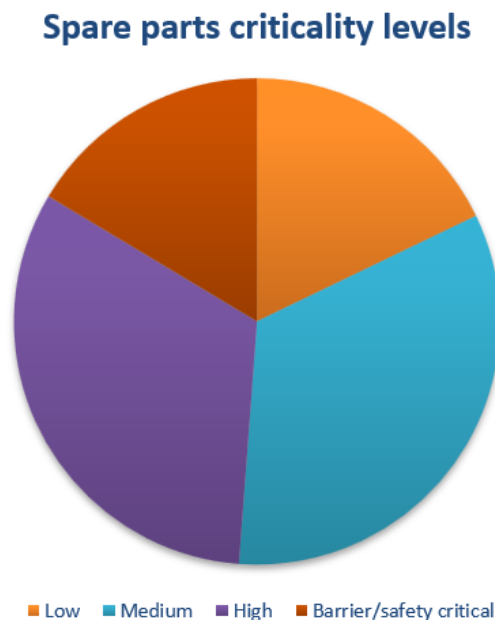

Figure 4: Pie chart of spare parts SKUs categorised based on equipment criticality

The numbers, ratios and charts above illustrate the scale and complexity of the spare parts situation at a typical offshore production facility and give substance to the classification problem and its importance.

The overall spare parts operations at the typical oil and gas company are managed at an annual level. This is due to the use of an opportunistic maintenance strategy, implying that one desires to exploit the planned downtimes of the production facility for maintenance work. This is a typical strategy in the offshore oil and gas sector as the “setup cost” of maintenance work (transport, manning, vessels, planning, etc.) and the cost of downtime are high. Therefore, the operators desire to exploit the planned downtime during summer to complete as much maintenance work as possible. Consequently, the same applies to spare parts operations, meaning that most spare part consumption happens during summer.

1.3 Problem

Current classifications methods are usually managed at the equipment level, using a criticality scale defining the equipment’s criticality. The companies utilise different criticality scales; some use numbers and others use letters or symbols. However, typical for most is that there is a need to further evaluate criticality and consequence analysis on a spare parts level.

In current practices, most spare parts for a piece of equipment are usually assigned the same criticality rank as the equipment itself. That is, all spare parts for a criticality “A” equipment will automatically be ranked as A as well. However, that may not necessarily be the case. For instance, consider a gearbox with a criticality rank of A. This gearbox consists of some parts that are highly critical for its functioning. This could, for instance, be the different shafts, bearings and the lubrication system, i.e. parts that are absolutely needed for the gearbox to function. However, several other gearbox parts are not so crucial for its functioning, meaning that they do not necessarily require immediate replacement upon failure, and might therefore receive a lower criticality rank.

The same principle applies to the opposite case; what is the criticality level of a spare part that is critical for the functioning of low-level-criticality equipment? The equipment is not deemed critical for operations itself; should its critical spare parts then be classified as non-critical? The problem becomes more complex as we account for other spare parts characteristics, such as the probability of failure and replenishment risk. A spare part might not be considered critical for the functioning of the equipment, yet, a high failure rate might make the part worthy of extra attention.

The examples highlight the need for a lower-level item criticality classification framework. It also illustrates how the existing equipment criticality rank functions as an essential indicator of the spare part criticality and should therefore be incorporated into the classification models, but, together with other spare parts characteristics, which also provides an indication of the overall criticality of the spare part situation.

1.4 Objective and Scope

Resulting of the above problem definition, Moreld Apply AS is interested in developing a multi-criteria spare parts classification framework. The overall objective of the framework is to use an equipment's existing criticality level, together with other equipment and spare parts characteristics, to establish precise criticality classes for each of the equipment's spare parts. Such a framework will include several steps in guiding the user through setting up the evaluation, preparing the analysis, and doing the analysis. Essential aspects will be the framework for selecting the most appropriate classification criteria, the data collection processes and preparation activities. These topics form the main body of our research.

Also, the classification framework is desired to be of a pragmatic nature, where results on established procedures and processes should be similar to real-life scenarios and cases. This will affect and form decisions on research methodology, philosophy and approach. Nevertheless, a literature review and research are done to provide the theoretical foundation of the thesis.

Objectives:

- Develop a framework for multi-criteria spare parts classification
- Test framework on real-life cases
- Validation of framework performance
- Validation of realism in framework and results

Sub-objectives:

- Ideas on where in a typical maintenance/asset lifecycle the framework is applicable
- Framework to be scalable and flexible
- Framework to function as simple tool for early-phase testing and pilot-projects for spare parts classification

Correct and reliable spare parts classification models will function as a valuable tool when optimising and controlling spare parts operations. Spare parts classification models provide the basis for spare part strategy development, where each spare part class, or category, with its characteristics, such as demand patterns, replenishment lead times, inventory turnover ratio, and others, will be subject to its spare part strategy. The strategy typically provides guidance on what to stock, how much to stock and where to stock it.

1.5 Delimitation

This thesis is not meant to develop an entirely new approach to spare part classification but merely, based on literature review and company interviews, to create a framework combining academia and industry best practices. The framework is desired to be easy to test and use, and we will therefore

delimit our model complexity in that regard. However, practitioners of the framework can easily enrich the model with several more criteria and attributes later on as the testing progresses, creating a model with desired complexity.

Even though the primary focus of this study is to develop the framework, a number of cases have been analysed to produce some results and highlight the framework's functioning. Some numbers and decisions are somewhat arbitrarily made purely for the sake of the framework development to delimit the total scope. Although some data is accessible through case company systems, it will be too time-consuming and not really necessary for the thesis results and objectives. However, this will naturally be noted down and documented.

An essential aspect of spare parts criticality classification is risk, criticality and consequence analysis of the spare part concerning equipment's functionality. Such an analysis requires a scope beyond this thesis and could potentially be another master's thesis of its own, specifically focusing on such topics.

It is the clients of Moreld Apply who will experience the direct benefits of an improved classification model. Therefore, data used for the case study is collected from companies operating at the NCS. Due to the possibility of data being sensitive, the data is anonymised, making it untraceable back to the companies. That being said, this will not influence the data quality or the model's performance.

1.6 Project Workflow

This section describes the different work stages of the thesis and the structure of the main activities in the analysis and classification framework. The goal is for the reader to get an overview of the different stages and the ability to follow the workflow. On the other hand, perhaps, more importantly, it ensures that the group can coordinate project execution so that the quality remains as high as possible. The workflow is split into three stages; (1) Orientation and data collection, (2) data analysis and framework development and (3) results and findings.

- **Stage 1: Orientation and Data Collection**

An important part of the first stage is getting an insight into the case companies and a familiarisation with the field of study. Due to less knowledge and experience around spare part classification, a thorough search of the existing literature was necessary and time-consuming. Gathering enough insight to facilitate and streamline the data-gathering process was essential. A continuous dialogue with relevant company representatives and internal supervisors provided support in collecting quantitative and qualitative data.

- **Stage 2: Data Analysis and Model Development**

The data analysis in stage 2 started with the evaluation of different classification approaches in order to find applicable models to the installed base data in the chosen cases. The purpose was to determine the most suitable approach for the thesis objective and research design. The installed base information, and all other applicable data, were provided from internal sources at the case companies and the analysis was mainly conducted quantitatively. The analysis and model development was carried out in Microsoft Excel. Excel performs well when analysing structured quantitative data and provides various data analysis tools. It is a reliable and commonly used programme, and compatibility with most ERP systems makes it easy to import data. Molenaers et al. (2012) puts forward Excel as a preferred programme for a similar classification tool due to its user-friendly interface. Furthermore, one of the sub-objectives of the thesis is to develop a scalable classification tool to be tested and perhaps adopted at the case company, with the characteristics described above being desirable. This thesis stage can be described as iterative because it is an ongoing process continuously modified, improved and re-evaluated.

- **Stage 3: Results and Findings**

The final result is a classification framework which is supposed to be an easy-to-use tool offering an alternative approach to classifying spare parts. Another goal is to introduce the idea of a link between the spare parts classification and inventory policies using an Inventory Policy matrix. At this stage, the final results were evaluated and validated. This was mainly done by comparing our results with similar research projects and their findings. Also, a short and informal feedback session with company representatives at Moreld Apply was carried out to validate the concept and classification approach. However, a thorough validation of classification results could not be done as it was deemed too time-consuming for both parties at this stage.

1.7 Outline of Thesis

This report will present the background and motivation for our project objectives and scope, followed by a chapter explaining relevant theory and research on the topic. Then we will introduce our method of approaching the problem, the case study, and the data analytical aspects of the thesis. At last, we will present our results, evaluate them and conclude on how they relate to the problem definition.

2 Literature Review

This chapter covers the literature study related to the thesis. Here we provide the theoretical foundation of the project. The chapter is meant to guide the reader through important concepts and aspects of spare parts management. Such an underlying understanding is important for understanding the problem at hand, the case studies, the analysis and other aspects related to the problem-solving processes.

In addition, we have chosen to structure our theory and research based on the standard Norsok Z-008. Oil and gas companies operating at the Norwegian Shelf are regulated on risk and maintenance issues as the potential consequences of failure might be damaging on a societal level. As a result, the Norwegian petroleum regulators have developed a bundle of standards called Norsok. These standards are meant to help companies on the Norwegian Shelf meet requirements set by the regulators while still remaining competitive. It can kind of be viewed as 40 years of best practices developed in the Norwegian oil and gas sector. Norsok Z-008 provides simple and thorough explanations of the most important concepts of risk and maintenance management, and therefore we have chosen to use it as the foundation for our research. The idea is to build the theory around the standard and then enrich it with other research and literature on the topic.

The thesis, and therefore this theory section, will mainly cover issues related to spare parts management, strategy and classification. However, there are a few topics and dilemmas that should be understood in order to fully comprehend the spare parts management issues at hand. Therefore, we will first go through some overall fundamental topics on offshore oil and gas, maintenance management, logistics and supply chain management to lay the foundation for our problem definition and the relevant literature. We will then focus the literature on spare parts management and classification.

2.1 Maintenance Management in the Oil and Gas Industry

The petroleum industry can be described as a capital-intensive industry. Capital intensive refers to a high-value asset structure with long lifetimes that demands considerable effort to maintain a high level of availability and reliability. Companies in capital-intensive industries use these assets for their primary business processes and a high level of availability and reliability is crucial to providing products and services. Downtime can result in lost revenues, customer dissatisfaction and/or public safety hazard, and the consequences of downtime are usually very costly (Wang and A. A. Syntetos, 2011a). Wang and A. A. Syntetos (2011a) divides downtime of a system into (i) diagnosis and maintenance, and (ii) maintenance delay caused by the unavailability of the required resources for maintenance and diagnosis, emphasising the importance of spare parts availability.

Maintenance is necessary and commonly used to extend the lifetime of capital assets and the main operating costs on the Norwegian shelf are related to maintenance, as well as daily operational costs

Petroleum. Breakdowns of assets will affect operations, but can also negatively impact the health and safety of crew and environment. Maintenance activities therefore must adhere to current technical and operational standards and specifications, mainly imposed by NORSOK, for safe and efficient operation. The role of maintenance is evident in the technical and operational health of production facilities, and maintenance activities are costly contributing to an average of 36.6% of total operating costs from 2009-2021 (Petroleum, 2021). The technical condition of assets in the industry is related to the performance and efficiency of the maintenance itself (Mouschoutzi and Ponis, 2022), accentuating the importance of the maintenance function within an organisation. Accordingly, maintenance management is a critical component of a well-functioning manufacturing process in capital-intensive industries.

2.2 Norsok Z-008

NORSOK, short for "the Norwegian Shelf's Competitive Position" in English, is a bundle of standards developed by the Norwegian petroleum industry. The complete standard covers every aspect of the offshore oil and gas industry. Its objective is to "ensure adequate safety, value-adding and cost-effectiveness for petroleum industry developments and operations" (Standards, 2022). The standards are based on more than forty years of experience from the Norwegian continental shelf and are today managed by Standards Norway. For our thesis, covering offshore risk and maintenance management, the section called "Z-008: Risk-based maintenance and consequence classification" will be the section of interest. This section provides guidelines and policies related to offshore risk and maintenance management, and functions as a valuable tool for oil and gas companies when deciding on maintenance-related issues. It serves as a handy tool for educational purposes as well. Figure 5 is found in the introduction chapter of the standard and illustrates the standard's content and structure.

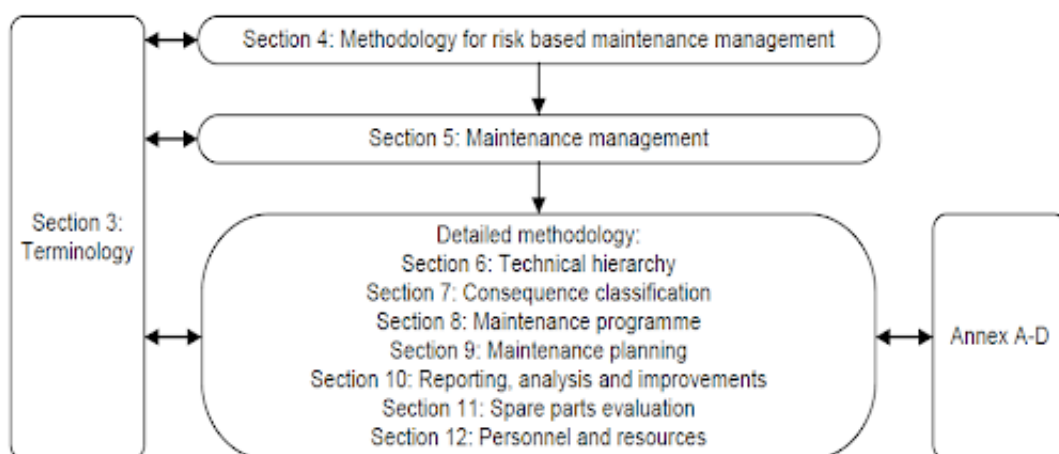

Figure 5: Illustration of content and structure of the standard

The NORSOK Z-008 standard provides requirements and guidelines for:

- How to manage the maintenance of critical equipment and barrier elements

- How to update preventive maintenance programmes based on risk and reliability analysis
- How to aid decisions related to maintenance using risk analysis
- How to establish a technical hierarchy
- How to classify equipment based on consequence rate
- How to evaluate spare parts

All these elements are closely related as they describe the overall maintenance strategy of a firm. The main idea is that the maintenance strategy should be assessed based on the risk and criticality of the respective equipment. The different elements should be viewed as a package, where each should be evaluated as a part of the whole. In the next sections, we will further describe a few of them in detail. The information in the following subsections has been gathered from (NORSOK, 2011).

2.2.1 Maintenance Management

According to Norsok, the purpose of this part is to:

- Describe the key elements and expectations of the overall maintenance management work process
- Describe where consequence classification is applicable in the maintenance management work process
- Highlight how risk management aspects are taken into account in the different steps in the process
- Link the main steps to the rest of the document where risk assessment details are described

This maintenance management process is a model proposed as an industry best practice and gives a short description of what each step typically involves. It briefly describes the different elements of risk assessment, consequence classification and probability of failure assessment as the overall themes.

2.2.2 Technical Hierarchy

According to Norsok, all equipment needs to be arranged in a hierarchy to effectively manage the resources used for maintenance purposes. Therefore it is a fundamental part of maintenance management that should be established in the early project phases. It describes the technical structure of the equipment, and provides an overview of all technical interdependencies between units in that equipment. A hierarchy like this enables the creation of item identifiers to store and retrieve data such as historical maintenance and general item documents. Norsok explains that the technical breakdown should be down to a level where requirements and history can be linked to the individual barrier elements, and its performance can be reported and verified.

2.2.3 Consequence Classification

Norsok defines consequence classification as a qualitative analysis of events and failures and the assignments of these consequences. This part describes how a standard consequence classification should be done, its flow of work and its relation to maintenance programmes. The aim is to disclose the unwanted effects of loss of function on different activities and processes. The consequence classification in Norsok defines:

- “workflow for consequence classification”
- “classification attributes”
- “consequence values/levels”
- “how to identify the main functions and sub functions”

Consequences can be negative and positive, but regarding loss of function, they are always negative for safety.

2.3 Spare Parts Management

Spare parts management is a field of study that, over the past decades, has acquired a significant interest in the literature. The literature covers many research areas, such as inventory control, maintenance and reliability, and supply chain management. It is especially comprehensive on the subject of inventory control strategies, where many models are developed. Several characteristics make spare parts different compared to regular products, thus, the management of spare parts is considered a particular case of inventory management (Hu et al., 2018), making it challenging. The basic questions to be answered are: what to stock, where to stock and how much to stock? (Molenaers et al., 2012) These are fundamental issues regarding spare parts management and lay the foundation for developing different spare parts strategies.

Hu et al. (2018) discusses technical approaches within the field of Operational Research (OR) for supporting spare parts management, among them multicriteria classification. Due to different requirements, Hu et al. (2018) divides inventory classification into two groups; classification for inventory control and classification for forecasting. The first is to determine an appropriate stocking policy for different spare part groups. The second is to choose the most suitable forecasting method for spare part groups.

Spare parts classification is an essential part of spare parts management to control the vast number of parts with different characteristics and specificities (Teixeira et al., 2018a). Each spare part class, or group, will eventually have their own rules on how many to stock, where to stock it, and required replenishment lead time, i.e. the spare part strategy. This is essentially the main reason for doing a spare part classification. It is desired to develop customised strategies for each group based on their criticality, annual value, lead times and other criteria. Referring to the theory on Reliability Centered

Maintenance (RCM), the maintenance programmes should be assessed based on the characteristics of the items to be maintained. However, to develop customised strategies based on item characteristics one must assess and establish the actual characteristics of interest. We need a systematic and reliable approach for categorising these items. We need a classification framework. However, this is not an easy task in the onshore and offshore petroleum industry due to operational assets' highly hazardous and capital-intensive nature. (Ratnayake, 2019).

2.3.1 Spare Parts Demand Drivers

Maintenance interventions in industries with capital-intensive asset structures without an adequate maintenance management system will be challenging. It specifically aims to support activities such as adopting inventory policies, ensuring part availability, and classifying spare parts. The demand related to spare parts is often differ generated based on the strategy of the maintenance management system, and Van der Auweraer et al. (2019) mentions three main sources of information that drive spare part demand: (i) size and status of the installed base and the spare part itself, (ii) the maintenance policy/strategy selected, and (iii) environmental factors that impact reliability.

Firstly, the literature review conducted by Van der Auweraer et al. (2019) suggests that factors such as product life characteristics, spare part life characteristics, and manufacturing rate greatly impact the demand related to spare parts. Furthermore, the age of products and systems and the probability of replacing a failed part also play a part. Secondly, the maintenance strategy can be the main underlying driver for spare part demand because it specifies when parts are replaced. A maintenance strategy is either proactive or reactive, and Yang et al. (2008) explain four different maintenance strategies; Predictive, Preventive, and Condition-based being proactive and Corrective maintenance being reactive. Proactive approaches focus on preventive and predictive measures used to prevent future failure of equipment by dealing with the problems before they occur. Reactive maintenance, also called breakdown maintenance, refers to a strategy where measures are applied after a part has already broken down. As technology has improved and maintenance methods and personnel have become more sophisticated in recent years, Swanson (2001) points out that some companies are converting to proactive approaches. Even though these approaches require greater commitments and efforts in terms of training, resources and integration, they are expected to provide enhanced levels of plant and equipment performance (Swanson, 2001). Thirdly, the environmental factors in which the equipment operates often have a considerable influence on the product reliability characteristics (Ghodrati, 2005). These factors are not only weather conditions, but also operator and crew training, maintenance facilities and general working conditions.) Ghodrati (2005) explains that maintenance programmes are generally chosen based on the age and status of the equipment, neglecting environmental factors. This creates poor system performance and higher life cycle costs due to many unexpected system failures. For this reason, the operating conditions should be considered when adopting support strategies since it affects

operational and maintenance costs and the quality of the service.

2.3.2 Spare Part Criticality and Control Characteristics

When classifying spare parts or any other type of classifying process, one needs to establish classification criteria or parameters. Such criteria provide the foundation of the classification process where each sample or case is compared and analysed against the given parameter. From a maintenance perspective, typical classification criteria could be machine failure rate, supplier lead times, reliability and criticality (Molenaers et al., 2012). The latter criterion, criticality, is for many a well-known concept and is often defined in terms of its risk character on production, safety and environment in the case of shortage or failure. However, research and practice have shown that such aspects are not necessarily easy to capture and measure.

In their analysis of the effects of different control parameters and strategic choices Huiskonen (2001) defines the concept of criticality based on two main aspects; process criticality and control criticality. Process criticality refers to the consequences a potential shortage of an item will have on the processes. For instance, the failure of a critical valve might pose a risk in terms of human safety and cause environmental damage. The consequence of not having a spare part at hand will be the same as this risk over time. That is, we have criticality defined in terms of process risk. However, such a definition of criticality is often recognised as quite difficult to measure and control, as such risk often is judged on subjective notions. In addition, it is difficult to quantify the total effects of failures and downtime as the repercussions might be severe and complex. The notion of subjectiveness is a known drawback and discussion in the risk analysis field in general and is well recognised in the literature.

On the other hand, a thorough determination might not be needed regarding process criticality, as it is often more practical with several degrees of criticality. Huiskonen (2001) suggest that relating the criticality to replacement time could be an effective solution. That is, one decides upon a maximum acceptable time from the time of failure to the time of replaced item as a basis for different degrees of criticality. Such a measurement, or KPI (Key Performance Indicator), would be similar to the well-known MTTR (mean time to repair) or the perhaps more similar MTTS (mean time to support). MTTR measures the time from failure until the item is fixed, and the MTTS measures the logistical aspects of the maintenance event, for instance, supplier lead time. For the case of spare part replacement, we would measure the time from failure event till the time of replaced item, a KPI which would fit somewhere between MTTR and MTTS.

Huiskonen (2001) further provides an example with three degrees of criticality: (i) the failure has to be corrected, and the spares should be supplied immediately, (ii) the failure can be tolerated with temporary arrangements for a short period, during which the spare can be supplied, (iii) the failure is not critical for the process and can be corrected, and spares can be supplied after a longer period..

(Huiskonen, 2001) Using time dimension as a measure of criticality makes it easier to consider control systems, e.g. choosing between material and time buffers to control the system. It also provides both the user and the supplier with a common means for setting the objectives and controlling operations performance.

The other criticality aspect mentioned by Huiskonen (2001), control criticality, refers to the ability to control the spare part availability. That is, how easy or difficult it is for us to acquire a new part if the installed part fails. The author further elaborates on control criticality is based on market complexity, vendor availability, supplier lead times, and predictability of failure. Jouni et al. (2011), in its research on global spare parts distribution chains, describes the same concept where it is referred to as availability risk. Jouni et al. (2011) evaluates availability risk, and operational criteria, as an efficient criterion for classifying spare parts. These are supply chain issues and will therefore be essential for effective spare parts management.

Huiskonen (2001) also mentions three more control characteristics of maintenance spare parts beyond criticality; demand pattern, specificity and value of parts.

Demand pattern

The demand pattern is a distinct characteristic different from many other products. Commonly used methods for classification are often based on demand volume and part criticality, e.g. ABC-classification, and fail to consider the intermittency of the demand patterns that are common for service parts. The nature of the underlying demand structure of spare parts, mainly based on demand arrivals and sizes, makes classification complicated and forecasting especially difficult (Boylan and A. A. Syntetos, 2010). One key reason being the presence of demand patterns common to spare parts, such as lumpy and/or intermittent demand. Van der Auweraer et al. (2019) also includes this among the three important spare part characteristics, especially related to demand. Although some spare parts will experience high and/or stable demand, most will face intermittent demand (Van der Auweraer et al., 2019; Wang and A. A. Syntetos, 2011b). Intermittency is defined as being subject to interruption or occurring at irregular intervals. Intermittent demand is therefore characterised by periods of zero demands with occasional non-zero demand periods. It has low variability in demand volumes with high inter-demand frequency. The characteristics of lumpy, smooth and erratic demand patterns can be depicted in figure 6.

Specificity

Specificity refers to the characteristics of user-specific parts and are commonly described as unique and low-volume parts. The wide range of spare parts is usually distinguished between generic and exclusive parts, where the exclusive are subject to specificity. Generic parts usually have few supply problems with many available suppliers. On the contrary, exclusive parts can be subject to supply issues as there are a single or few suppliers to choose from and are often characterised by high supply delivery time and sporadic demand. Exclusive parts can be further categorised into specific and strategic parts.

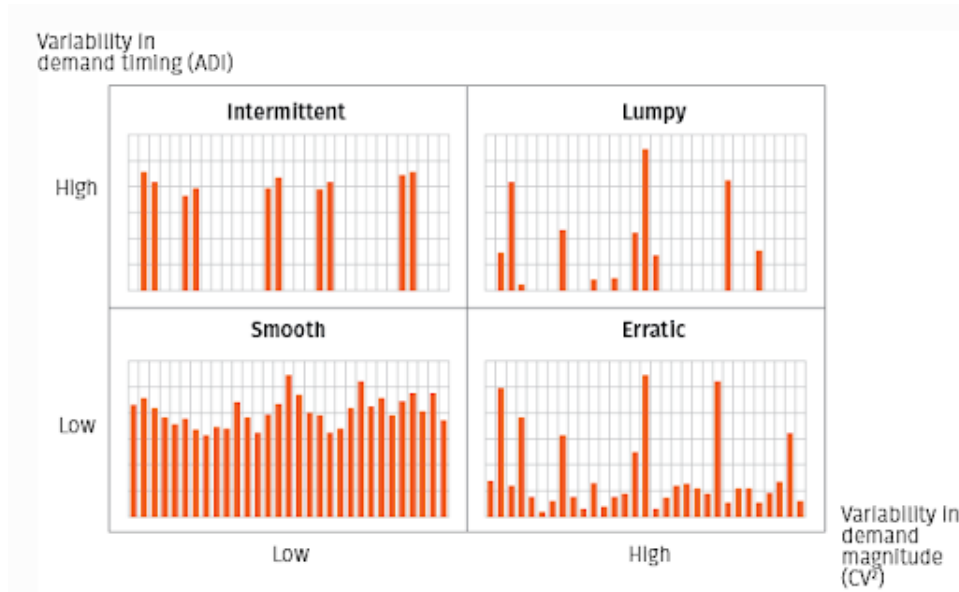

Figure 6: Four categories of demand patterns common to spare parts (Rodin and Katsov, 2019)

Specific parts are particular to a piece of equipment and/or only available through a single supplier. Strategic parts are specific parts “whose expected wear-out time is not foreseeable”, characterised by long delivery times and relevant costs (Cavalieri et al., 2008). The specificity characteristic of exclusive parts gives a significantly higher risk of obsolescence.

Part Value

The value of a spare part is also a common control characteristic in the classification process, and is important for the selection of maintenance and logistics strategies. Huiskonen (2001) mentions storage of high-value parts as an unappealing option and encourages to find other solutions. Due to the attributes described earlier, exclusive parts often experience higher costs. Generic parts often have many suppliers and few supply problems, hence the lower price. Here the efficiency of the replenishment strategies is the primary concern so that the costs do not increase unreasonably in proportion to the value of the parts.

2.4 Spare Part Classification

Spare part classification is an important aspect of the spare parts management and evaluation processes. Based on certain characteristics such as risk, price and material movements, the idea is to decide upon the spare parts’ criticality and importance, and thereafter the spare parts strategy. Such a classification is also important for logical and systematic handling of spare parts in terms of spare parts management and policy.

Norsok Z-008 states that the spare parts strategy, i.e. number of, location and lead time, shall be based on results from consequence classification and other relevant analysis. The importance and criticality of the spare parts are based on the importance and criticality of their respective equipment or system, i.e.

the equipment or system that the spare part is a part of or is meant to fix. However, the case company has found this practice to produce somewhat inefficient and costly procedures, as the statement can be interpreted as follows; if a piece of equipment is classified as critical, then all its spare parts should be classified as critical as well. For instance, if a motor is decided to be highly critical for production uptime, then all of its spare parts, from tiny screws and bolts to lubrication and bearings, shall be critical as well. And that is necessarily not the case. Most motors spares are most likely not critical for motor functioning, meaning that they should not be given the same criticality level as spares that are crucial for the motor. Otherwise might result in costly stock-at-site policies for all of its spare parts. Or put the other way around, if a spare part is considered as critical for a piece of equipment that is not critical, should the spare part be treated as critical in line with other highly critical spare parts? Both cases highlight the need for a lower-level framework for spare parts criticality and consequence analysis as a basis for spare parts classification. Lower level in the sense of the level below maintainable item level, referring to the technical hierarchy in section XX. That is, the level concerned with components and spare parts that together build the equipment or system. NORSOK Z-008 further categorize spare parts into three main categories:

- Capital spare parts:
 - Vital to the functioning of the plant, but unlikely to suffer a fault during the lifetime of the equipment
 - Delivered with unacceptably long lead times from the supplier and usually very expensive
 - Often these spare parts are characterised by substantially lower costs if they are included with the initial order of the system package
 - Also called insurance spare part
- Operational spare parts:
 - Spare parts required to maintain the operational and safety capabilities of the equipment during its normal operational lifetime
- Consumables:
 - Item or material that is not item specific and intended for use only once (non-repairable)

This known and well-established spare parts classification framework is practiced in the maintenance field throughout the industries. However, the classification does not necessarily provide any information on whether a spare part is critical or not. There exist other methods for classifying spare parts, some incorporating other relevant aspects and characteristics of the individual spare part situation. But first, let us elaborate on some relevant classification fundamentals.

2.4.1 Spare Part Classification Models

There exist several well-established classification models that vary based on the user needs, as well as the users' views on the classification criteria dilemma. These models are well researched in the literature and used throughout the industries. Each model will have strengths and weaknesses depending on the situation. According to Cavalieri et al. (2008), there are two types of classification methods to define spare part criticality; (1) "quantitative methods, implying the adoption of drivers based on a numerical value", and (2) "qualitative methods, assigning criticality levels based on a rough judgment or on scoring methods". Cavalieri et al. (2008) further illustrates the main approaches for spare parts criticality analysis in the illustration seen in figure 7.

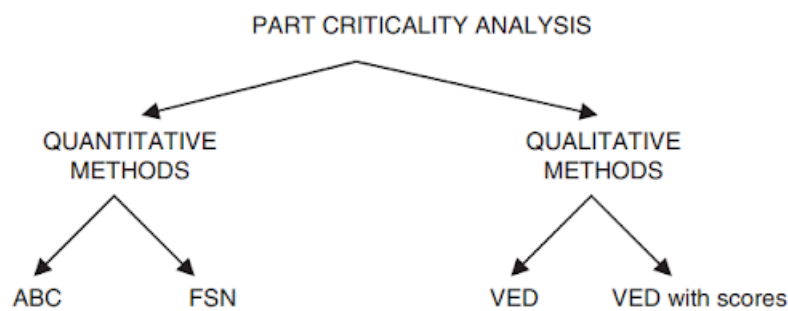

Figure 7: Parts Criticality Analysis

Some models are purely quantitative and others are merely qualitative. We will also see that a few try to combine the best of both approaches.

ABC Classification

ABC classification is a common quantitative method for deciding on strategies and policies for spare parts. The idea is to classify all spare parts into three main groups (A, B and C) based on their ranking compared to the selected criteria. Hatefi et al. (2014), in their research on multi-criteria classification models, describes these groups to be:

- A group: for very important items,
- B group: for moderately important items, and
- C group: for relatively unimportant items.

The method is based on the Pareto principle, which famously states that 20% of the sources causes 80% of the consequences, often referred to as "the vital few", and the remaining 20% of the consequences are caused by 80% of the sources, or "the trivial many". Similarly, the A group is most important and should receive the most attention. B is also important but should be given a bit less. C is less important and will be the least emphasised group. The A group will contain relatively few items but accounts for a large portion of the consequences. In contrast, the C group will have relatively many items but represents a more minor part of the consequences, as stated by Ramanathan (2006).

The ABC method is known for its simplicity and widespread use among material and maintenance practitioners. Simplicity comes in the sense that only one classification criterion is used, namely the annual use-value or dollar value. The annual use-value is derived from the product of annual demand and average unit price (Ramanathan, 2006). This makes it applicable to most situations, and the system makes it trivial to create strategies and policies for each group. However, with this simplicity comes the method's drawback: one classification criteria alone is often insufficient to cover the range of different item characteristics. Studies have revealed that classical ABC analysis only functions effectively when we have a situation of homogenous spare parts assortment. That is, the method is only successful when the assortment mainly differs in terms of one classification criteria, i.e. the annual use value [8]. Such situations are for most industrial companies not realistic, whereas one in contrast, holds spare part inventories of a much more heterogeneous character. Even a moderate-sized company may control thousands of inventory items that do not necessarily have similar characteristics Ramanathan (2006). As a result, the research community, as well as the industries, has emphasised the need for incorporating several more classification criteria into the models (Ramanathan, 2006; Molenaers et al., 2012; Hatefi et al., 2014; Guvenir and Erel, 1998; Huiskonen, 2001; Teixeira et al., 2017)

However, as the variety of control characteristics of items increases, the one-dimensional ABC classification does not discriminate all the control requirements of different types of items (Huiskonen, 2001). Referring to the example above on process criticality related to the important valve, the impact of a shortage of a critical part may be a multiple of its commercial value, which makes an ordinary ABC analysis an insufficient control tool.

Several researchers and experts in the area suggest that one should incorporate several more classification parameters in the models to cover a more comprehensive and detailed picture of the spare parts situation. Spare parts might vary in several manners, which should be recognised in our classification models. Guvenir and Erel (1998) suggest that criteria such as replenishment lead times, commonality, criticality, obsolescence and substitutability should be considered as well. Cavalieri et al. (2008) illustrates an example where classical ABC analysis is enriched with other classification parameters such as MTTF (mean time to failure) and MDT (mean downtime). These two variables are added to determine the criticality level of the spare parts, where a low MTTF indicates a high frequency of failures, and a high DMT means that breakdowns are long-lasting. Other models integrate other variables, as we will see later in this chapter.

FSN - Fast-, Slow- and Non-Moving

The FSN model is another quantitative method for spare parts classification [main]. This method also classifies the spare parts into three main groups: F for fast-moving items, S for slow-moving items and N for non-moving items. However, the FSN model differs from the ABC classification in that FSN uses spare part demand patterns as classification criteria, resulting in a classification focused on

the material movement rates of the spare parts (Cavalieri et al., 2008). In this case, it is normal to measure the average spare part consumption over a given period and use this while also considering the replenishment lead time, as a classification criterion. Cavalieri et al. (2008) further elaborates on the different classification groups and describes a rule of thumb when deciding on groups: F will normally have a demand of 10 or more items per period, S is for items with a demand of less than ten items per period, and N is for items with no demand over the period. The authors also note that the method especially comes in handy when one wants to highlight an item's obsolescence and non-movement.

In their case study on using FSN in a chemical firm, Devarajan and Jayamohan (2016) defines the model as a "stock turnover ratio-based analysis". That is, the annual usage of an item divided by its annual average stocking levels. In contrast to the rule of thumb provided by Cavalieri et al. (2008), Devarajan and Jayamohan (2016) groups the items based on inventory turnover ratio:

- Fast-moving (F) are those items whose stock turnover ratio is greater than 3.
- Slow-moving (S) are those items whose stock turnover ratio is between 1 and 3.
- Non-moving (N) are those items whose stock turnover ratio is below 1.

VED - Vital, Essential, Desirable

When discussing qualitative classification methods, the VED model is often recognised. VED is also based on item criticality and classifies spare parts into three; V for Vital, E for essential and D for desirable (Teixeira et al., 2017). This criticality is defined in terms of its functional importance to operations and maintenance (Gajpal et al., 1994). The analysis is based on the maintenance expert's knowledge and judgment of the situation. The researchers describe the characteristics of the three classification groups as follows:

- Vital spare parts include all items, which, if not in stock, could result in huge losses due to the non-availability of the equipment needing the spare.
- Essential spare parts are those for which stock-outs could result in moderate losses. In this case, the equipment may be operable with some difficulty but cannot be used for long periods without the spare.
- Non-availability of desirable spares will cause only minor disruptions but may lead to more serious operational problems in the long run.

(Cavalieri et al., 2008) illustrates the classification logic above with an example: if the non-availability of an item inhibits the execution of a production process and there is no standby equipment, then the item can be defined as Vital. If the same item is backed up by a standby unit, then it comes into the Essential category. If the item does not affect the process or the safety, it is categorised as Desirable.

The researcher, Cavalieri et al. (2008) and Gajpal et al. (1994), soon after emphasises that there is no generic methodology for performing the analysis and that the method is case-specific. In addition, most

research on the method recognises the way to suffer from drawbacks related to subjectiveness. After all, the classification is based on personal experience and opinions. Gajpal et al. (1994) therefore suggests the use of VED combined with AHP (Analytical Hierarchy Process), a structured ranking technique for complex decision making (we will discuss AHP in the next subchapter).

In this analysis, the researchers first identify three factors that are considered as main drivers for spare part criticality: the type of spare required, the replenishment lead time, and “and the status of availability of the production facility when an original part fails, and a spare part is required”. The latter parameter is the impact the non-availability will have on production in failure cases. Each classification criteria is then enriched with three alternatives as follows:

Type of spare required

- standard part available from the shelf
- standard part whose availability is not certain
- non-standard part to be fabricated according to specifications

Procurement lead time

- less than 3 months
- varying from 3 to 6 months
- more than 6 months

Availability of the production facility

- alternative production facility available
- alternative production facility available if suitable modifications are made in the equipment or process
- no alternative production facility available

Finally, the criticality analysis of spare parts is achieved through a pair-wise comparison of the three driver values within a team of users. The AHP results in a compound index, which is adopted as a comprehensive score for defining the VED classification index

The example above also showcase the idea of including several classification criteria, as discussed earlier. In maintenance and inventory management, these issues are also known as Multi-Criteria-Inventory Classification (MCIC).

2.4.2 MADM - Multi-Attribute Decision Making

MADM-methods aim to determine which of multiple comparable alternatives is the most satisfactory to solve the problem. MADM is defined by Zhang (2014) as “making preference decisions by eval-

uating and prioritising a limited set of alternatives based on multiple conflict attributes”. Since the attributes have different impacts on the outcome, the significance of the attributes is determined. Therefore, a judging matrix and eigenvectors of the attributes are components used in most MADM-methods (Zavadskas and Podvezko, 2016). Three steps are often needed to solve MADM-problems: (i) Determine weights of attributes, (ii) determine and normalise the attribute values for each alternative, and (iii) aggregate the normalised attribute values into an overall index for the ranking process of alternatives (Zhang, 2014). MADM-methods operate using numerical values, although the attributes can be both quantitative and qualitative. Once determined, these values remain static during the solving process. The authors of this thesis utilise a MCIC-approach, a subfield of MADM, to answer the research question. It focuses on grouping inventory items regarding several criteria as an extension to single-criterion studies, which is regarded as too limited to fit the realities of modern business decision-making.

2.4.3 AHP - Analytic Hierarchy Process

Another well-established method for spare part classification is AHP - Analytic Hierarchy Process. Originally developed by Thomas L. Saaty, AHP is a widely used tool for classification and decision-making processes (Saaty, 1987). According to Teixeira et al. (2017), AHP is considered a leading classification method, as well as one of the most popular multi-criteria decision-making techniques. The main idea is to develop relative weights, also referred to as scalars (Ramanathan, 2006), compound index (Cavalieri et al., 2008), weighted vectors (Hatefi et al., 2014), or eigenvalues (Guvendir and Erel, 1998), for the different criteria which will provide the basis for pairwise comparison. Gajpal et al. (1994) describes the decision model to be “based on structuring the problem in a hierarchy”, where we at the top-level place the overall objective of the process. For instance, in our case, the objective could be something like “Classification of critical spare parts”. Then, the middle level is concerned with the classification criteria, or parameters, we want to use. Referring to the example provided in section XX above about VED, such criteria could be the type of spare required, supplier lead time and availability of the production facility. Other parameters mentioned earlier such as annual consumption, use-value and obsolescence could also be used. At last, the decision alternatives for each criterion are placed at the bottom level. Referring to the same example, this could be lead time as criteria and three degrees of lead times as decision alternatives. These three levels form the general AHP model, however, more levels might be added between the top level and the bottom level depending on the problem structure.

The method has found several different use-cases, from Partovi and Burton (1993) famously applying the method for inventory classification, to Silva Neves and Camanho (2015) using it for prioritizing IT projects. Hosseini and Khaled (2019) applied the AHP model for resilient supplier selection and Jiang et al. (2019) used it for the classification of weld defects. Triantaphyllou, Mann, et al. (1995), in its research on AHP as a methodology for engineering decision-making, states that the popularity

of the method comes with the (normally) simple mathematical properties of the model, as well as the easiness of obtaining the input data needed. The method is also much appreciated because of its ability to simultaneously incorporate both qualitative and quantitative data (Yiğit and Esnaf, 2021; Molenaers et al., 2012), which often comes in handy in MCIC-problems. The application of AHP helps to reduce the complex decisions to a series of simple comparisons. Consequently, it helps to synthesise results showing the best decision and the clear reason for the choice[20]. Triantaphyllou, Mann, et al. (1995) verifies this and adds that the method also verifies the consistency of the comparison and provides a mechanism to improve it in the cases where the comparisons are not consistent. Nevertheless, it is also important to add that there are some known drawbacks to AHP discussed in the literature.

Ramanathan (2006) states, "The single most important issue associated with AHP-based studies is the subjectivity involved in the analysis". This is a recognised problem among researchers, and attempts to reduce the subjectivity bias have been researched. Others, such as Subramanian and Ramanathan (2012), find this subjectiveness a strength as it makes it possible to consider several subjective opinions from decision-makers. The authors emphasise this feature as attractive when combining the AHP with other methodologies that usually deal with objective data. This can be seen in the "increasingly growing literature on applications in which AHP has been combined with other tools such as quality function deployment, meta-heuristics, SWOT analysis and data envelopment analysis" (Subramanian and Ramanathan, 2012). See Ho (2008) for more details on AHP combined with other methodologies. Hatefi et al. (2014) also finds the argument of subjectiveness as a possible drawback and adds two more points: First, when the number of items is increased, the size of respective pair-wise comparison matrices (PCMs) grows, which in turn makes it difficult reaching to consistent matrices and therefore eliciting the right weight vectors. Second, when applying the AHP method, it is generally difficult for the decision-maker to assign accurately crisp numbers to each pair-wise comparison (Hatefi et al., 2014).

Regarding the first point of Hatefi et al. (2014), Saaty (1987) suggested overcoming this problem by limiting the number of criteria to 7 at each level in the hierarchy. Anyhow, as we can observe from the literature, there are some pitfalls to be aware of when using the AHP model and this must be recognised by practitioners of the model, as well as documented in research and reports.

2.4.4 MASTA - Multi-Attribute Selection Spare Tree Analysis

Braglia et al. (2004), in their research on spare parts inventory management using a "multi-attribute classification method", develops a new method of spare parts classification. Their model is called MASTA, short for Multi-Attribute Selection Spare Tree Analysis, and incorporates both the classification process and the strategy development into one model.

The model is divided into two sequential steps, a first step naturally being spare parts classification

followed by a step for spare part strategy selection (Teixeira et al., 2018b). In the classification process the model identifies four spare parts categories in the classification process using a logic tree. The desired criteria create the decision nodes of the logic tree. For instance, Braglia et al. (2004) uses “Spare parts plant criticality”, “Spare supply characteristics”, “Inventory problems”, and “Usage rate”, as their classification criteria. Each criterion includes several attributes describing its composition and structure. For instance, under the criteria on supply characteristics, we find attributes such as “lead time”, “cannibalism”, “potential suppliers”, and more. The criteria on usage rate consist of attributes on “Number of identical parts in plant”, “Redundancies”, and “Frequency of failure”. The attributes are then divided into the three VED-categories mentioned above.

The AHP method is used to support the decision process at each node. The decision alternatives at each node, i.e. for each classification criteria, are based on the VED logic, classifying each decision alternative into vital, essential or desirable. Similar terminology such as critical, important and desirable can also be used (Teixeira et al., 2018b). In the second step of the model all four spare part groups are compared with different spare part inventory strategies. This results in what the authors call an “inventory management policy” (IMP) matrix. The matrix will function as a tool for strategy selection for each spare part group. The authors refer to the method as being consistent in the selection of inventory strategy on all types of facility equipment.

3 Methodology

This section covers the overall conceptual framework and methodology of the thesis. It highlights the project workflow, research method and strategy and provides a step-by-step procedure for the case study, data collection and analysis. Together this forms the overall classification framework where the framework steps will provide the foundation of the analysis. This section also describes the sources and methods of data collection, data cleansing and pre-processing, and an explanation of the data and model validation mechanisms. Limitations of the data collection are also described.

3.1 Overview of Analysis and Framework Procedure

This section presents the authors' procedure when developing the classification framework. The overview comprises seven steps, including the inputs and outputs associated with each step, which will be explained in the following subsections. The complete overview is shown in figure 8.

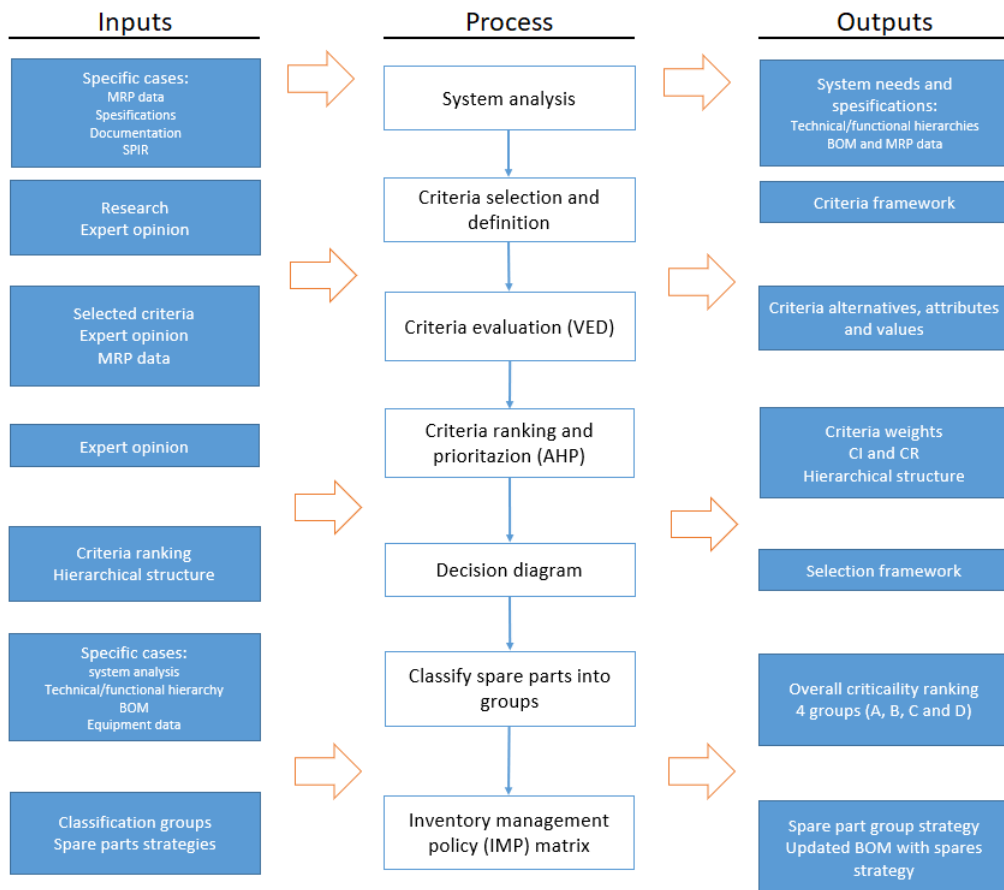

Figure 8: The overall classification framework

The framework can be considered divided into two sequential phases. The first phase is the process of setting up the framework. We want to go through all the steps solely to set up, adjust and customise the framework. The framework development is the main part of the analysis, where most data collection

is done. This is also the phase where the availability of experts and specialists is essential, as one must really understand the spare parts situation at hand to set up the framework in a correct manner. The second phase concerns the analysis of the specific spare parts. It is here we apply the framework established in phase one. This is a simpler and less demanding phase as we now merely are to score the spare parts based on their characteristics with respect to the framework. However, that being said, the same people doing the first phase should also be involved in the second phase as they are the experts on both the framework, its functioning and design, and the spare parts situation to be analysed.

3.1.1 System Analysis

Before the actual classification processes can begin, a thorough systems analysis is necessary to understand the system at hand, its needs, interfaces and connections, and how the system functions. There are several established tools and methods for system analysis; among them are technical and functional hierarchies, the system of system (SoS) diagrams, and process flow diagrams.

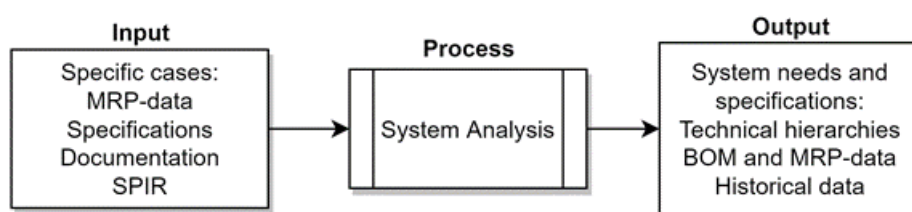

Figure 9: First step: System Analysis

This step involves developing/retrieving technical and functional hierarchies on the selected cases and collecting BOM and MRP data. Also, in this step, the analyst/decision-maker will get an overview of the data management aspects of the system. This is an important finding in the systems analysis as data availability sets the preliminary conditions for how the classification should proceed. Also, the data availability is often of varying quality. The results of this step should be an overall system understanding to facilitate the work in the remaining steps, as well as the needed technical specifications and data to perform the analysis.

For the system analysis, the various data sources were mostly related to the case companies and their databases. Needed SAP permissions were granted, where the module for Computerised Maintenance Management System (CMMS) was made available. Such systems are designed for maintenance and asset management, where all data related to maintenance and MRP is produced and obtained. Here we got access to the complete functional hierarchy of the industrial plant of interest, BOM and MRP data, and historic maintenance activities. In addition, one of the employees with expertise within the CMMS provided us with an excel sheet covering essential data for spare parts.

The authors also got access to internal documentation systems. In this system, one can find most

data related to technical specifications of specific equipment. This is typically data provided by the vendor upon procurement and consists of technical drawings, datasheets, certificates, and maintenance procedures. SPIR, an abbreviation for Spare Parts and Interchangeability Record, was a significant source of data related to this system. SPIR is an extensive list of spare parts recommendations from the OEM (Original Equipment Manufacturer). The spare parts might be proprietary to the OEM or subcontracted to other vendors. SPIR was a beneficial data source as it contains data on PDT (planned delivery times), unit prices, and the true spare part BOM. True spare part BOM in the sense that some parts in the total equipment BOM is not to be considered as spare parts as they pose other characteristics on failure and maintenance. Therefore, they are not included in the maintenance scope as spare parts (at least not to be changed or shifted soon). Typical examples of this are parts related to structure.

Furthermore, semi-structured interviews were conducted with maintenance personnel at the company. This was done in order to develop a qualitative and descriptive understanding of the system. Such data covers the practical aspect of the analysis, where different connections, interfaces and correlations are examined. For instance, how certain practicalities affect the maintenance data, or how relationships between the different types of data are connected. The interviews also uncovered why some cases are embedded with poorer data availability and quality than others.

Limitations for this step were mainly related to the data available at the case company and, to be more precise, the time data for spare parts consumption. The plan was originally to use spare part demand patterns as a classification criterion. However, we had only access to total annual consumption per spare part and not specific dates. This is primarily because oil and gas operators usually operate with annual numbers on spare parts volumes to calculate the yearly usage value of each spare part. The ones with the highest annual usage value are the most important and deserve the most attention, i.e. the ABC classification method described in section 2.4.1. Discussions with the CMMS employee described above revealed that more precise time data on spare parts consumption could be made available, for instance, by analysing historical maintenance work orders where the specific spare part is used. However, this process was deemed too resource and time-consuming as we would need access to other internal systems at the case companies. In addition, a complete list of timestamped spare parts consumption would be complex to retrieve as; (1) the part is used in several different systems for both planned (preventive) and unplanned (corrective) maintenance work, making it a complex query systemwise, and (2) the degree to which the operators at the production facility report the usage of a spare part in the work orders is of varying quality. As a result, we did not go further into the demand patterns for spare parts. However, such practicalities as just described are a good illustration of the importance of having semi-structured interviews with company personnel as described in the subsection above.

Another limitation related to the data collection process for system analysis is related to the internal documentation system described above. The availability of the data found here is of varying quality

depending on which production facility we are analysing and varying from case to case. In some cases, most, or all, needed data, such as technical drawings, datasheets and purchase orders (POs), are found. However, only some, or even nothing, is available for other cases. This limitation made it difficult to find suitable cases for analysis and will be a significant limitation later on when the framework is potentially applied for real. Our solution to this problem was the development of a classification criterion attribute called “Availability of technical specification”, a criterion meant to measure the degree of availability of such data described above. This was an attribute created under the criterion for logistics characteristics of the spare parts, as the non-availability of documentation can be boiled down to a logistical issue (it is first when the item is to be ordered, moved, or done some activity with, that documentation is needed). The logic is that spare parts with lower availability of the technical specification are to be ranked as more critical than those with higher availability. The ranking of this specific criterion will naturally be weighted relative to the other criteria attributes used for the classification process.

3.1.2 Criteria Selection and Classification

After identifying the system needs and specifications, the spare part classification process continues by selecting and defining the classification criteria used to evaluate spare parts’ criticality. To select appropriate criteria for the framework, views and judgements from designated experts were fundamental. A review of the existing literature on the field of study was also essential.

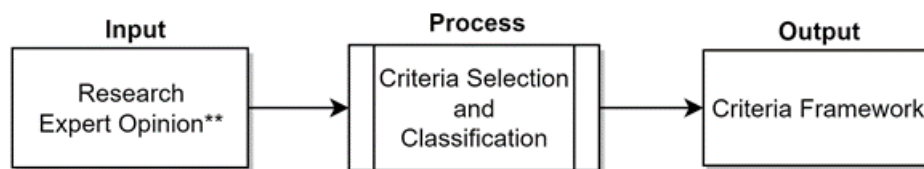

Figure 10: Second step - Criteria Selection and Classification

**Expert panels, specialists, and discipline managers as explained in 1.5 (label?)

Firstly, it is important to establish a common understanding of some definitions used in this step. Both criteria and criteria attributes are used to describe the classification parameters used in the classification process. While these two may look alike, they actually differ in which hierarchical level of the classification they are used. The criteria are used to describe the characteristics of the spare parts, and the attributes are used to describe the criteria characteristics. That is, the criteria are first-level items, and the attributes are the level below. See figure 11 for an illustration of the decomposition.

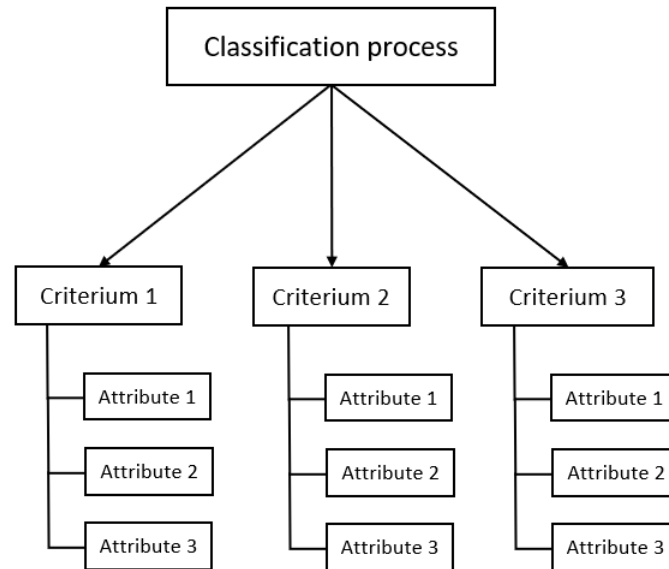

Figure 11: Hierarchical structure of classification criteria and criteria attribute

Assigning attributes to the criteria provides the evaluation with a deeper classification layer. The perhaps more complex criteria can be broken down into several “easy to comprehend” types of subcriteria. The method could, in practice be applied to all the classification criteria depending on the situation and decision-makers’ preference toward the classification processes. However, the more criteria and attributes one chooses to include, the more complexity is added to the model. For instance, Braglia et al. (2004), in their illustration of the MASTA-model, use four main criteria embedded with six to eight attributes each. This gives a more complex and nuanced model consisting of several decision trees and evaluation processes. Another reason for the decomposition of criteria is related to the AHP, which requires comparison elements of a homogeneous nature of measurements. This means that each criterion must be of the same units of measurement.

The research philosophy for this step is somewhat abductive. The literature review on spare parts classification, multi-criteria decision-making, and classification criteria selection, revealed best practices and current discussions amongst researchers and maintenance practitioners on the topic. However, simultaneously with the theoretical review, case company data collection, interviews and system analysis were done, providing an inductive approach as well. The criteria selection and definition would typically be subject to changes by the DMs and analysts at the case company due to differences in spare part cases and situations. For some situations, other criteria and attributes might be considered more important and can replace others or be added as additional criteria.

The result of this step is the overall criteria framework that the classification process will be based on.

3.1.3 Criteria Evaluation

The next step of the process is to identify and define the different criteria alternatives of the selected criteria. The VED analysis is used to structure each alternative into “Vital”, “Essential”, or “Desirable”. Desirable is the condition that is the most advantageous in terms of the criticality it has related to the criteria. The opposite being vital. The alternatives might be quantitative or qualitative which is considered one of the key strengths of using VED combined with AHP.

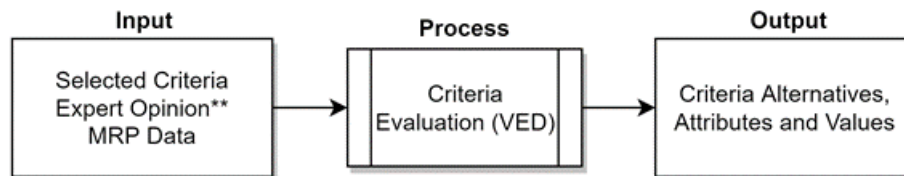

Figure 12: Third step - Criteria Evaluation

The inputs for this step are first the selected classification criteria and attributes from the previous step. Then, for each criterion and attribute, MRP (Material Requirement Planning) data is needed. Such data typically consist of lead times, equipment criticality, stock levels, manufacturer, model/type and prices. These data are gathered from the CMMS as mentioned in ???. Also, equipment and product data, such as technical drawings, data sheets and purchase orders, are used. OREDA is used for the estimation of the probability of failure.

Similar to the previous step for criteria selection, such an evaluation of criteria and attributes alternatives should be subject to expert opinion. The decision-makers must thoroughly understand the spare parts situation at the company, the maintenance practices, the supply chain characteristics and the procurement routines. Hence, we recommend using expert panels with multi-disciplinary backgrounds related to these topics.

Also similar to the previous step, this step was developed with an abductive approach. We started at both tails of the research methodology spectrum and gradually formed the step. This step is also based on verification from maintenance employees at Moreld Apply concerning the different criteria alternatives and their values. That is, we have used maintenance personnel competence and subjective experience to evaluate the different alternatives. In other words, experts have somehow interpreted their beliefs on the situation, which can be compared with interpretivism, a research philosophy emphasising the importance of human interest.

The results of this step are a complete identification, valuation, and VED classification of criteria and attribute alternatives. This creates a framework of boundary values for each criterion/attribute, which will be used as the basis for the AHP and decision diagrams in the following steps.

3.1.4 Criteria Ranking and Prioritisation

A ranking system is needed for cases where classification criteria are decomposed into several attributes. For this, AHP is utilised to establish each attribute’s significance relative to each other and relative to the “parent-criteria” it describes.

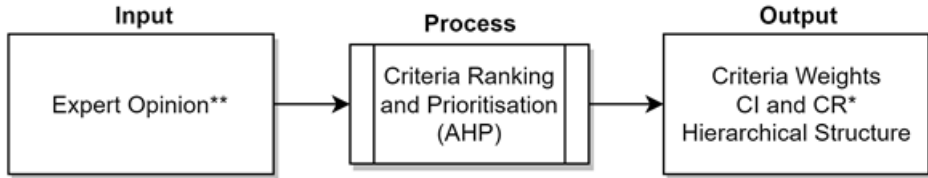

Figure 13: Fourth step - Criteria Ranking and Prioritisation (AHP)

*Consistency index and consistency ratio

The evaluations in the previous step are now converted to numerical values for each element, representing the assessor’s beliefs on the attributes’ relative importance. This involves the creation of pairwise comparison matrices (PCMs), normalising them, and calculating the overall attribute priority, often referred to as eigenvalues in matrix theory. Then consistency ratios are estimated to make sure that the comparison is made consistently. However, first, we need to organise the criteria, their attributes, and the attributes alternatives into a hierarchical structure.

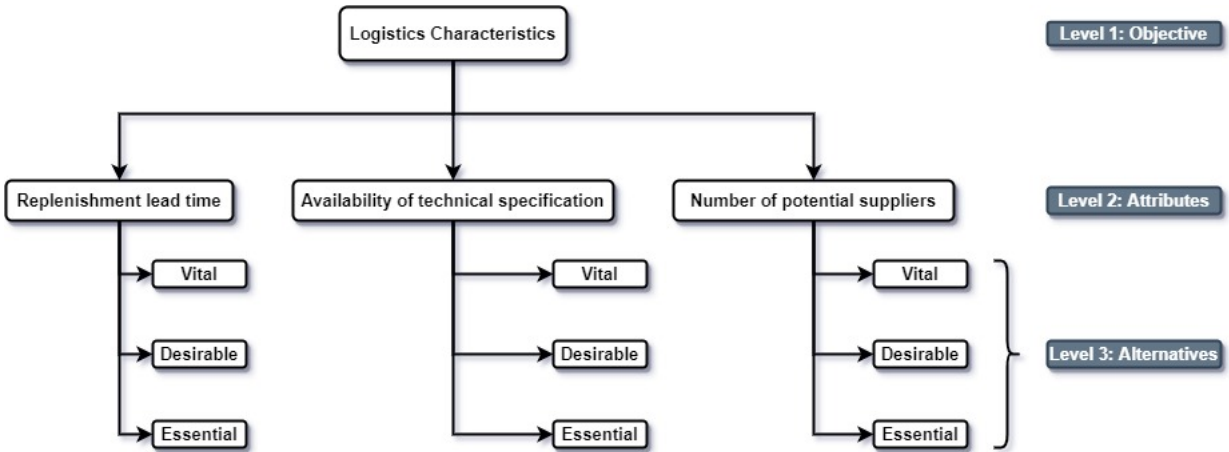

Figure 14: Hierarchical structure of the AHP with respect to the criteria “Logistics characteristics”

A known drawback of the AHP is the notion of perceived loss of control due to the “black box” nature of the calculations (we will come back to this in the discussion). That is, one can quickly lose track of what is going on, eventually giving the assessor a feeling that simply some inputs are used, then some processes are happening, and outputs are coming out. As a result, one might not understand where the numbers on priority, eigenvalues and consistency originate. Hence, the black box comparison. Therefore, a detailed description of each step is needed. In the following sections, we will provide a pragmatic description of each step, enriched with mathematical equations and properties. However, one

might need to combine this with the AHP results in the analysis chapter to understand the process truly, as the mathematics might be perceived as a bit abstract.

1. Pairwise comparison matrix

The first step of the AHP process is to fill in the pairwise comparison matrix for the comparison of attributes. Referring to figure 14, this will be the first comparison activity where the attributes (level 2) are pairwise compared with each other with respect to the objective (level 1). The comparison process is structured around simple questions regarding one attribute's importance, or criticality, compared to the other regarding the objective. The typical question will be: "how important or critical is attribute one compared to attribute two in terms of logistics characteristics of the spare part?". The assessor then gives a score to attribute one based on the question. The score must be given within the AHP rating scale (ranging from 1/9 to 9), which can be found in appendix D. The PCMs form $n \times n$ matrices where n equals the number of attributes included in the classification process.

$$A = [a_{ij}] = \begin{bmatrix} \frac{w_1}{w_1} & \frac{w_1}{w_2} & \dots & \frac{w_1}{w_n} \\ \frac{w_2}{w_1} & \frac{w_2}{w_2} & \dots & \frac{w_2}{w_n} \\ \vdots & \vdots & \ddots & \vdots \\ \frac{w_n}{w_1} & \frac{w_n}{w_2} & \dots & \frac{w_n}{w_n} \end{bmatrix}$$

Figure 15: AHP pairwise comparison matrix (Nguyen, 2014)

The term a_{ij} represents the assessor's given importance of attribute i compared to that of attribute j , where i and j goes from 1 to n . If the weight of attribute i equals w_i and the weight of attribute j equals w_j , then a_{ij} equals w_i divided by w_j . See figure 16 below for illustrations PCM with numbers.

$$A = \begin{bmatrix} 1 & 2 & 6 \\ \frac{1}{2} & 1 & 3 \\ \frac{1}{6} & \frac{1}{3} & 1 \end{bmatrix}$$

Figure 16: AHP pairwise comparison matrix illustration with numbers (Nguyen, 2014)

The lower half of the matrix illustrates the reciprocal relationships of the comparisons. This means that given a pairwise comparison of a_{ij} (a_{ij} being a number in Saaty's scale), then a_{ji} will logically be $1/a_{ij}$ as the comparison now is reversed. The comparison elements at the diagonal of the matrix will naturally be equal to 1, as the attributes are compared to themselves. The sum of each matrix column, $S = a_{ii} + a_{ji} + \dots + a_{ni}$ will be used to normalise the matrix in the next step.

2. Normalise matrix and calculate eigenvalues/weights

In this step, we will standardise or normalise the matrix. This is essentially the same matrix as before, with the same attributes along the rows and columns. However, this matrix differs in the sense that each value in the matrix is now divided by the sum S of the belonging column in the first comparison

matrix. By doing this, we can calculate the total relative weight of each attribute, often referred to as the normalised eigenvalue. This is simply the average of all attributes normalised scores. See Nguyen (2014) for detailed proof of the eigenvector with its eigenvalues. In practice, this value tells us about the assessor(s) overall opinion on each attribute (see analysis section for illustration). The attribute's total weight adds up to 100%, or 1. This is one of the benefits of normalising data as we are now operating with ratio data, making it easier to work with and more intuitive to comprehend.

3. Consistency matrix, -index and -ratio

The third matrix is created to establish the consistency index (CI) and consistency ratio (CR) of the comparison process. We want to ensure that the different pairwise comparisons are made thoroughly and with a bit of thought. A consistent comparison matrix would mean that if A is ranked as more important than B and B more important than C, then it should be inherent that A is more important than C. The example with A, B and C is relatively straightforward; however, as the number of comparison elements grows, it becomes more challenging to keep track of the consistency. Therefore, it is normal to develop consistency indicators to capture whether this transitive property exists in the comparison matrices or not. The consistency ratio (CR) was developed by Thomas L. Saaty in 1980 when he first introduced the AHP. We will not go into the detailed theory behind the concept in this thesis; however, we will highlight the fundamental idea of CR and its mathematical properties. See Nguyen (2014) for details on the mathematics of AHP consistency.

The main idea behind CR is that there will always be some degree of inconsistency in such comparison processes because of human nature, our own personal experience and goals, and the way we perceive, capture and use information. However, inconsistency has an important function as it helps us modify our consistent understanding. In other words, it lets us learn and change our minds. Yet, for the sake of the AHP, the inconsistency must not become too large as it affects the results. Therefore, it is mathematically only allowed for an inconsistency that is a maximum of one order of magnitude smaller than the consistency. That is, we allow for a maximum of 10% overall inconsistency. This allows for minor variations in the comparison process without completely changing each comparison's true identity. From Wedley (1993) we learn that the consistency index (CI) is mathematically defined as:

$$CI = \frac{\lambda_{max} - n}{n - 1} \quad (1)$$

"where λ_{max} is the largest principal eigenvalue of a positive reciprocal pairwise comparison matrix ($a_{ij} = 1/a_{ji}$, $a_{ii} = 1$) of size n " (Wedley, 1993). The matrix is defined as positive when all elements are strictly greater than zero ($a_{ij} > 0$, for i and $j = 1, 2, \dots, n$). This will always be the case for AHP PCMs as the comparison scores never will be zero. In practical terms, this means that the larger inconsistency there is within the comparison matrices, the larger λ_{max} will get. It also implies that if we had a perfectly

consistent matrix, then λ_{\max} would be equal to the matrix size n . This will in turn, cause the CI, our measurement of inconsistency, to arrive at zero, as the numerator in the equation for CI above now will be zero.

Saaty further describes consistency ratio (CR) as the ratio between the CI of the comparison matrix and the mean CI from a large sample of randomly generated matrices of the same size. The CR will then function as a measurement of deviation solely from inconsistency.

$$CR = \frac{CI}{MeanRandomCI} \quad (2)$$

Naturally, a somewhat consistent comparison will have a substantially lower CI than what is generated by random matrices. Hence, the CI rule of 10% was claimed by Saaty, with the logic and reasoning discussed earlier. In table 1 provided by Wedley (1993) we can observe the different random mean CI based on matrix size n . We can also see that it is deemed as tolerable with a CR between 10% and 20%. The population size of the randomly generated matrices is 500. Furthermore, Saaty states that the size of the matrix, meaning the number of criteria or attributes for the classification framework, should be limited to a maximum of 7 plus/minus 2 ($n = 7 \pm 2$). This is to make sure that the overall consistency of the matrix is reliable. If the number of elements compared is too big, then the CR rule of a maximum 10% variation might result in a higher overall inconsistency within the matrix.

Size of matrix	Consistency index from randomly generated matrices, $n = 500$	Saaty's cut-off consistency indexes	
		Acceptable (10%)	Tolerable (20%)
3	0.58	0.058	0.116
4	0.9	0.09	0.180
5	1.12	0.112	0.224
6	1.24	0.124	0.248
7	1.32	0.152	0.246
8	1.41	0.141	0.282
9	1.45	0.145	0.29
10	1.49	0.149	0.298

Table 1: Saaty Random and cut-off consistency indexes

Continuing the comparison process, when the CR is not acceptable/tolerable, the next step will be to ensure that the assessor understands how the comparison elements function together. The analysts must find out where the inconsistency is produced in the pairwise comparison process. The assessor(s) must then repeat the comparison until the CR is at a desirable level. The first comparison process is completed when the CR arrives at acceptable/tolerable levels.

4. Repeat the process for attribute alternatives

Now that we have established the principal eigenvalues, or relative weights/priorities, for the attributes, with an acceptable/tolerable level of consistency, we can start with establishing the priority of the at-

tribute alternatives with respect to the attributes. This is essentially the same process as the previous comparison; however, we now make a pairwise comparison of the level 3 AHP elements with respect to level 2 (see figure 14). That is, we want to find the normalised eigenvector of the VED alternatives with the same rules for consistency evaluation.

An essential aspect of AHP and spare parts classification is that the decision-makers must first observe and understand the VED classification provided in a previous step. That is, we need to understand what vital, essential and desirable (the alternatives, level 3) mean for that specific spare part, as well as their decided values, in terms of the attribute criticality. This means that the comparison questions would be something like: "In terms of replenishment lead time, how critical or important is a spare part with a vital lead time (lead time i 3 months) compared to a part with a desirable lead time (lead time j = 14 days)". The assessors provide a score based on the AHP-rating scale.

In table 11 the analysis (section 4.4, we can observe that we, as assessors of the framework, have given this exact comparison a score of 5. Referring to the AHP scale, this implies that we believe vital replenishment lead time (i 4 months) is "strongly more important" than desirable replenishment lead time (j = 14 days). Similarly, as in the previous comparison, we will eventually arrive at a normalised eigenvalue for each attribute alternative, indicating its importance in reference to the attribute.

When the normalised eigenvector is established, with a desired degree of consistency, there are a few more steps to be done for the comparison of the alternatives. First, we want to establish the composite weights for each alternative regarding the specific attributes. The composite weight is simply the product of the attribute normalised eigenvalue, found in step two of AHP explained above, and the alternative normalised eigenvalue, found in step four of AHP just described above, giving us the total aggregated weight of the attribute alternative. Mathematically, the attribute eigenvalue can be viewed as a global weight for the attribute, let's call it G , whereas the attribute alternative eigenvalue will be the local weight, let's call it L , of that alternative with respect to the specific attribute. The product of these two weights will then give the composite weight.

$$\sum_{i=1}^n G_i L_{ik} \quad (3)$$

Where n is the number of attributes, i is the index for attribute reference, and k is the index for alternative reference.

The composite weight gives us the true priority of that specific attribute alternative. Also, such a calculation of an aggregated priority, using both attribute weight and alternative weight, provides a more dynamic evaluation of the attribute criticality. The attributes are now situation-specific and can change the degree of importance depending on how the specific spare part scores on the alternatives.

In practice, this means that an attribute becomes more important if a spare part scores as vital on that attribute alternatives than if it scores as desirable. For instance, the attribute "Replenishment lead time" will be evaluated as more important, meaning a higher composite weight, for a special spare part with a lead time of 3 months than it would have been for a standard, off-the-shelf spare part with a lead time of 10 days.

The second and last step of comparing the alternatives, and the last step of the AHP for this specific criterion, is to develop boundary values for each VED classification; Vital, Essential and desirable. This is, like other previous steps, a process where the management, experts and specialists must be included. Here we want to establish numerical limits for each VED class based on constructed scenarios for the attribute alternatives. For instance, if a part is ranked as vital on replenishment lead time, vital on the number of suppliers, and desirable on availability of technical specifications, what is then the total VED ranking of that spare part with respect to the logistics characteristics? Here, the expert opinion comes to play, and the decided strategy, or logic, will be the procedure for all spare parts with those characteristics in terms of the logistics criterion.

One usually will first calculate the lower limit of the "vital" class. So, for instance, if the assessors believe that the combination of a vital situation (meaning alternative) for attribute 1, as well as a vital situation for attribute 2, independent of the situations for the remaining attributes, is the minimum possible degree of a vital spare part situation with respect to the overall classification criterion of interest, then this will create the lower boundary limit for vital for the respective criterion. In practice, this is simply the sum of the respective composite weights, i.e. the sum of composite weights of alternative "Vital" for attribute 1 and alternative "Vital" for attribute 2. This means that all sums of composite weights that are equal to, or greater than, this value will be classified as vital in terms of that criterion. Next, one must calculate the upper limit for the "desirable" class. This will be a similar process. However, we are now analysing the maximum possible degree of a desirable spare part situation with respect to the overall classification criterion, using the same attributes. The range of values between this upper value for "desirable" and the lower limit for the "vital" will then be equal to "essential".

3.1.5 Decision Diagram

Multi-criteria classification models, such as the AHP, are often complemented by using a decision diagram or tree to present the model. In this case, the classification process will be presented using a decision tree that highlights the criticality level of each criterion based on the order of sequence of the decision nodes.

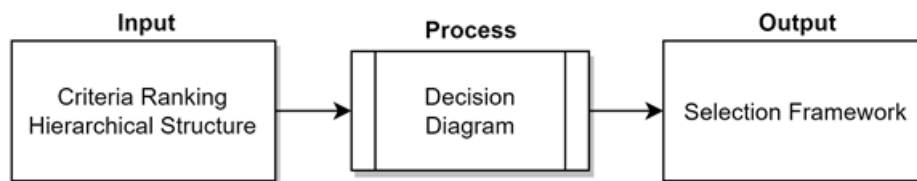

Figure 17: Fifth step - Decision Diagram

The diagram provides the user with a logical and intuitive breakdown of the classification process. It is meant to guide the assessor through the decision nodes based on the characteristics of the spare parts. Each node represents a classification criterion selected in previous steps, and the decision path will be decided based on how the spare part score to the different criteria. The complexity of the decision tree increases with the number of criteria and attributes included in the evaluation as the tree grows with each added node.

The input for this step is mainly the decided classification criteria from step two of the framework, as these make up the decision tree nodes. Each criterion's VED classification, i.e. the criterion alternatives, is used to create the arcs, or decision path lines, between the different nodes. Therefore, the research and literature review provided for that step will also apply to this step. In fact, for this step, we have chosen to use the decision diagram developed by Molenaers et al. (2012) in their case study on spare part criticality classification. This is because we based our classification criteria on their research and because we believe this decision diagram covers the essentials of a vast number of variants in the literature.

3.1.6 Classify Spares Into Groups

All the steps prior to this point are a general process to create the framework and will be similar in most instances. This stage is where the actual classification of spare parts occurs and requires the input of information and data from specific spare parts cases.

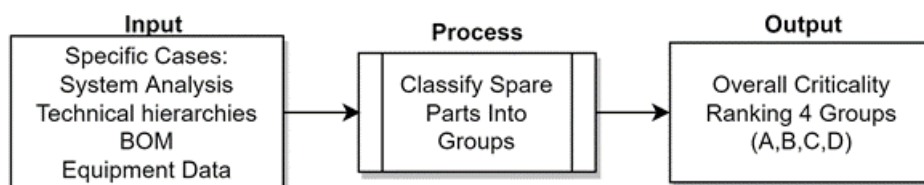

Figure 18: Sixth step - Classify Spares Into Groups

This step results in an overall criticality ranking of the spare parts based on the criteria ranking and selection framework created in the previous steps. The criticality rank is divided into four groups; A, B, C and D, with parts with the highest criticality being classified into group A.

3.1.7 Inventory Management Policy Matrix

A natural next step after the classification is to decide what the inventory policy for each group should be. The IMP matrix highlights that the classification framework can provide a basis for developing spare parts management strategies based on a criticality classification. IMP is a simple and useful tool that proposes an inventory policy using a matrix that assigns a maintenance strategy to each group.

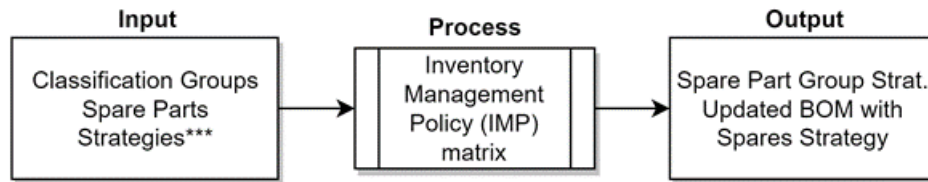

Figure 19: Seventh step - Inventory Management Policy Matrix

***Existing strategies on spare parts inventory management. For instance, no stock, 1 unit stock or multi-unit stock with SS and ROP

3.2 Research Design

The research of this thesis is mainly conducted based on quantitative data. The main body of the thesis consists of analysis related to installed base information, spare parts, lead times, stock levels and similar data, requiring a quantitative approach. However, to develop both a conceptual and a technical understanding of the systems and equipment to be analysed, as well as knowledge related to the case company on maintenance policies, procedures and processes, qualitative data gathered from the case company's experts was needed as well. This was mainly done through informal interviews and meetings.

As a result, we end up with a mixed-methods approach as described by Johnson et al. (2007). This is an approach where it is desired to achieve deeper knowledge and understanding through the combination of both quantitative and qualitative methods, or as described by the authors, one "combines elements of qualitative and quantitative research approaches (e.g., use of qualitative and quantitative viewpoints, data collection, analysis, inference techniques) for the broad purposes of breadth and depth of understanding and corroboration". Figure 20, also developed by Johnson et al. (2007), illustrates the various approaches and the connections between the quantitative and qualitative techniques.

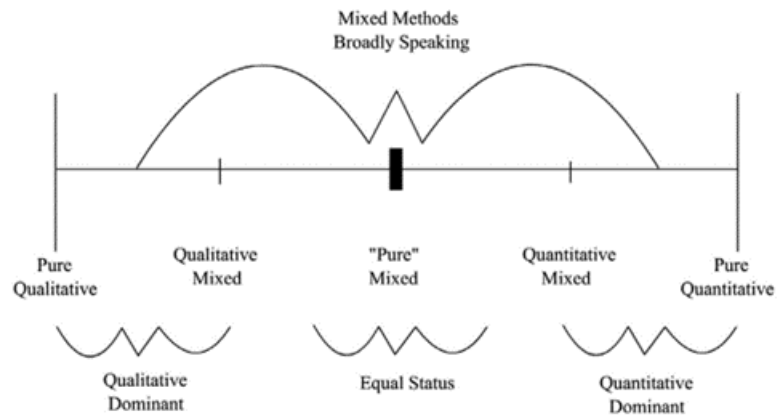

Figure 20: Mixed methods

Referring to figure 20, with our analysis being most dependent on the quantitative data analysis, a definition of our approach would fit somewhere near “Quantitative Mixed”.

Another argument for choosing a mixed-method approach is that our client, Moreld Apply AS, desires a thesis of pragmatism. They are interested in a real-world and realistic framework for spare part classification. The “primary philosophy of mixed research is that of pragmatism” (Johnson et al., 2007) coincides well with the notion of this thesis being of a practical nature. The method is designed for theoretical and practical knowledge where one wants to “consider multiple viewpoints, perspectives, positions, and standpoints”. As the thesis’s objective is to develop a practical framework for spare parts classification based on case studies, such a pragmatic approach is well suited.

3.3 Validity

The overall validity of the data collected is regarded as high, and every data point was extracted from internal systems that are in use today. Data collection was done in collaboration with a data expert at Moreld Apply who confirms the validity and actuality of the information. The validity of data is not of the utmost/absolute importance as the framework is supposed to be a modifiable classification model with the ability to fit most cases. The data is merely to be used as a reference in the production of the model. However, it has indeed been meaningful to get an insight into how the data is structured in their systems in order for the model to be as relevant and suitable as possible. Nevertheless, consensus between this thesis’ methods and literature indicates that the data and methods used hold high validity.

4 Analysis and Framework Development

This chapter covers the analysis and framework development. Here we will follow the same procedure as explained in the methodology chapter. The idea is to develop the framework for spare parts classification step-by-step, and then apply the framework to specific cases.

4.1 System Analysis

The framework development begins with an analysis of the system in question. The following content will be based on the system analysis of a specific case, an electric motor.

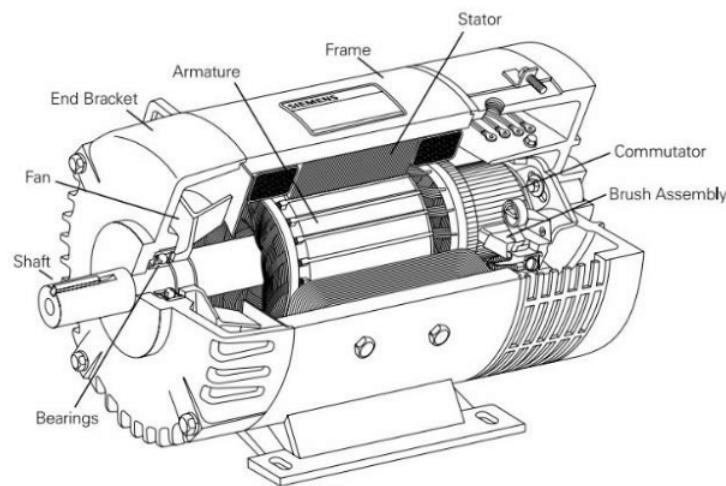

Figure 21: Assembly drawing of a general direct current (DC) electric motor (Mohsen and Al-Sharkawy, 2017)

The original drawings and documentation of the cases will not be provided in the thesis as it is considered sensitive information. However, the typical documentation to find for the systems analysis are assembly drawings with BOM, vendor-specific data on maintenance procedure and SPIR, datasheets, process diagrams such as P&IDs and similar, technical and functional hierarchies, as well as MRP data from the ERP system. However, for this specific case, the availability of technical specifications and other maintenance-related data was quite low. We could only find the most basic data for the equipment in the CMMS.

System summary	
Functional location:	Tank pump motor
Equipment:	Electric motor, DC, 690V, 60Hz
Criticality:	6
Maintenance type:	Preventive maintenance (PM)
Technical specification:	Limited
OREDA MTF (years):	0,57
Unit price:	kr 111 476,00

Table 2: Electric motor general information

The systems summary provided in table 2 illustrates the general information about the electric motor. The data is gathered from the CMMS, where the technical hierarchy and some MRP data were available. Table 3 contains a list of the spare part BOM. These parts of the motor are deemed as spare parts, subject to repair or replacement. The data is anonymised, meaning that neither the material number nor the material description is the actual data. However, the material description summarises the correct item type. Only specific data on the model, dimensions, sizes etc., are removed.

Equipment: Electric motor, DC, 690V, 60Hz		
Material nr	Material description	Total installed
1	Bearing	2
2	Brush holder	1
3	Carbon brush	1
4	Brush spring	1
5	Stator	1
6	Fan	1
7	End head	2
8	Armature	1
9	Protection cover band	1

Table 3: Spare parts BOM for the electric motor, DC, 690V, 60Hz

The final table, table 4, summarises the systems analysis results. This is the data which, based on existing literature and case studies, is reckoned essential for the development of the framework for spare parts classification. Some table columns contain the exact same data from top to bottom. This is due to the data only being available on an equipment level. So, for example, since the electric motor is subject to preventive or planned maintenance, its spare parts will take on this characteristic too. The same for the criticality level.

Material nr.	Material description	Equipment criticality	Probability of failure*	Lead time**	#Suppliers	Techn. specification	Maintenance type
1	Control unit	6	5,5	18	Several	Limited	PM
2	Cabling & junction box	6	16,0	18	Several	Limited	PM
3	Subunit	6	4,3	18	Several	Limited	PM
4	Thrust bearing	6	22,8	18	Several	Limited	PM
5	Instrument vibration	6	16,0	18	Few	Limited	PM
6	Radial bearing	6	6,9	18	Several	Limited	PM
7	Stator	6	40,0	18	Medium	Limited	PM
8	Fan	6	17,7	18	Medium	Limited	PM

Table 4: Electric motor, results and data from system analysis

*Probability of failure as MTTF in years ** Lead time in weeks

Now that we have analysed the system and its characteristics, we can start the classification process by defining the spare parts criticality characteristics and selecting appropriate classification criteria.

4.2 Criteria Selection and Criticality Definition

Based on the results from the system analysis, we can develop a draft of potential classification criteria and attributes that best defines the spare part criticality. As described in the literature study, item criticality is often

divided into two main categories: (1) process criticality, when item failure might cause severe consequences for the production facility, typically in terms of human safety, environmental impact and production loss. And (2) control criticality, also referred to as availability risk, is the criticality in the replenishment of an item. That is, an item is considered process critical when its failure has a potentially severe impact on the production, personnel and environment, and control critical if it is difficult to ensure availability of the part upon failure. A way to think about process criticality is from the perspective of maintenance and production, and control criticality from the perspective of logistics i.e. processes concerned with procurement and supply chain management.

Based on the assessment of criticality, literature review on spare parts classification, and feedback from internal expertise, a cautious selection of criticality classification criteria is made.

Criticality criteria	Description
Equipment criticality	Equipment criticality refers to the criticality class of equipment. The O&G industry typically distinguishes between barrier/safety critical and production critical (high, medium, low). High and barrier are considered most critical.
Probaility of item failure	The probability of failure is the likelihood of failure or breakdown of the spare part.
Logistics character.	This criterum is based on three subcriteria, or attributes, which together defines the overall logistics characteristics of the spare part
Maintenance type	The type of maintenance performed on the equipment.

Table 5: Criticality criteria and criteria description developed by (Molenaers et al., 2012)

The three criteria “Equipment criticality”, “Probability of failure” and Logistics characteristics forms the criticality aspect of the process described in the section above. These criteria together describe the overall process criticality of the equipment. Especially as the already existing criticality levels, the one on the equipment level most likely is based on some sort of risk assessment and consequence classification of its own. It being a reasonable indicator of their own assessment of the equipment’s effect on process criticality. Examining the reliability of the existing criticality levels is beyond the scope of this thesis. The classification criteria called “Logistics characteristics” forms the control criticality aspects of the framework. This criterion is concerned with the characteristics related to the replenishment of the items, and it’s the only criterion where decomposition of the criterion into attributes is needed to cover the classification criterion’s nature and situation fully. See figure 11 for a description of the relations between criteria and attributes. Table 6 contains the chosen criterion attributes and their descriptions.

Logistics criticality attributes	Description
Replenishment lead time	The total elapsed time from when a material need is communicated until the item has been received, checked, binned and is available for use.
Number of potential suppliers	The number of potential suppliers who are able to deliver the specific spare part to the requestor
Availability of technical specifications	The availability of the technical specifications (BOM, CAD-CAM drawing, data sheets and order text) of the article

Table 6: Criterion attributes for “Logistics characteristics” developed by (Molenaers et al., 2012)

Such a decomposition of classification criterion into criterion attributes could in principle be applied to all criteria, depending on the decision-maker(s) desires and preferences regarding the complexity and user-friendliness of the framework. However, there should be a logical reasoning behind the criteria breakdown.

4.3 Criteria and Attribute Evaluation

VED classification evaluates each criterion and attributes importance depending on the spare parts situation. In this regard, criteria alternatives can be established with values and boundary limits. For instance, the probability of failure often referred to as failure rate, is divided into three alternatives: more or equal to one time/year, more or equal to 1 time/5 years and less than 1 time/year, and less than 1 time/5 year. The different scenarios are then evaluated based on the VED classification. That is, for the previous case on failure rate, the alternatives are evaluated as vital, essential and desirable, respectively, based on the criterion’s importance given the specific situation (alternative).

Criticality criteria	VED categories		
	Vital	Essential	Desirable
Equipment criticality	High criticality Barrier/safety critical	Medium criticality	Low criticality
Probability of item failure	≥ 1 time / year	≥ 1 time / 5 year and < 1 time / year	< 1 time / 5 year
Replenishment lead time	≥ 3 months	> 14 days and < 3 months	≤ 14 days
Number of potential suppliers	Few 1 - 3 suppliers	Medium > 3 and ≤ 9 suppliers	Several > 9 suppliers
Availability of technical specifications	Limited specifications available (information can be found in overall system descriptions)	General specifications available (P&ID, General arrangement, but no datasheet or anything specifying mfr, model nr or mfr pn)	Detailed specifications available (Datasheet with data on mfr, model nr and mfr pn, detailed drawings and specs on dimensions, capacities, effect and other product specifications)

Table 7: VED-classification of criteria and attribute alternatives

Similar to the criteria selection process presented in the section above, decisions on the values for the alternatives should also be based on expert opinion, given the specific situations. Referring to the example on replenishment lead time, the experts on that matter, being either supply chain managers, purchasers or maintenance managers, or even all of them together, should have a say when deciding what is considered a vital lead time and what is

considered essential or desirable.

4.4 Analytic Hierarchy Process

In “Criteria selection and definition”, we found that one of our main classification criteria, the one concerning logistical aspects of the spare part, was to be decomposed into three subcriteria or attributes; replenishment lead time, the number of potential suppliers and the availability of technical documentation. To use these as attributes for the classification process, they must have a ranking compared to each other and compared to the overall criterion. For this, the AHP is used. See table 8 for the structure of the AHP for “Logistics characteristics”.

Pairwise Comparison Matrix	A	B	C
A - Replenishment lead time	1,00	6,00	3,00
B - Number of potential suppliers	0,17	1,00	0,33
C - Availability of technical specification	0,33	3,00	1,00
Sum	1,50	10,00	4,33

Table 8: PCM of the attributes under the “Logistics characteristics” criterion

Alongside the rows and the columns in table 8, we can see the attributes defining the logistical characteristics of the spare part. Each table element represents the pairwise comparison of the two respective attributes. For instance, we can observe that the element a_{1,2} contains the value of 6. This means that the assessor believes that the attribute “Replenishment lead time”, i.e. the row item, is “strongly to very strongly MORE important” than the column item, in this case, “Number of potential suppliers”, when relating them both to criticality in terms of logistics. See the rating scale in appendix D for a score of 6. Similarly, the value of cell a_{2,1}, where the comparison is made with “Number of potential suppliers” as row item and “Replenishment lead time” as column item, will logically be 1/6 as this attribute is considered strongly to very strongly LESS important than the other. This is called the reciprocal relationship, when a value is the inverse of the other, and will always be the case in a pairwise comparison. The diagonal will naturally have values of one since attributes are compared with themselves in these cases. The bottom row is the sum of each column is used for calculating the standardised/normalised matrix.

Pairwise Comparison Matrix	A	B	C	Normalised Eigenvector
A - Replenishment lead time	0,67	0,60	0,69	65,3 %
B - Number of potential suppliers	0,11	0,10	0,08	9,6 %
C - Availability of technical specification	0,22	0,30	0,23	25,1 %
Sum	1,00	1,00	1,00	100,0 %

Table 9: Normalised PCM of the attributes under the “Logistics character” criterion

Table 9 contains the normalised values of the comparison rankings in table 8. This means that each table element

is divided by the column sum noted at the end of the previous section. The average of each row in this matrix provides us with the normalised eigenvalue for each attribute, i.e. the total weight. For instance, in this case, we can see that replenishment lead time is assessed as the most important attribute, accounting for about 65% of the total importance of logistics characteristics. All three eigenvalues build the eigenvector, meaning that the column “Normalised eigenvector” is considered the normalised eigenvector of the PCMs.

Consistency matrix for attributes comparison	A	B	C	Weighted Sum	Consistency Vector
A - Replenishment lead time	0,65	0,58	0,75	1,98	3,04
B - Number of potential suppliers	0,11	0,10	0,08	0,29	3,00
C - Availability of technical specification	0,22	0,29	0,25	0,76	3,01

Table 10: Consistency matrix for attributes comparison

The table above is the consistency matrix of the pairwise comparison of criterion attributes. Each table element is found by the vector product of the original PCM in table 10 and the eigenvector explained in the last section. The sum of each row provides us with the weighted sum vector, which essentially is the matrix dot product of the original PCM and the eigenvector. This is a matrix operation where a 3x3 matrix is multiplied with a 3x1 matrix, giving us another 3x1 matrix, i.e. weighted sums vector. However, these are only steps done to find the vector of utmost interest, the consistency vector. Dividing the weighted sums vector with its respective eigenvector provides the consistency vector. These are the values under column “Consistency vector” in table 10. As we can observe in this column, these values are almost equal to three which, not coincidentally, is also the number of matrix elements n, i.e. number of attributes of our PCMs. These values are the maximum eigenvalues of the PCMs, indicating some minor inconsistency as the numbers are not exactly equal to three. The average of these provides us with lambda max, which is used for calculating the consistency index (CI). CI is found using equation ??, giving us a value of 0.009. The consistency ratio is found between this CI and the randomly generated CI from Saaty’s random CI table (1), giving us a CR of .016. As we can see from the upper row in the same table, with a matrix size of n = 3, an acceptable CI is equal to .058, indicating that our PCM is consistent. That is, during the comparison process, there were no occurrences of combinations of pairwise comparisons where there exists a logical flaw of priority. The verified consistency completes the first comparison process, and the same process is done for the attributes alternatives.

Pairwise comparison of alternatives	Attribute alternatives			Normalised	Composite
	Desirable	Essential	Vital	Eigenvector	Weight
Replenishment lead time					
Desirable	1,00	0,50	0,20	12,2 %	8,0 %
Essential	2,00	1,00	0,33	23,0 %	15,0 %
Vital	5,00	3,00	1,00	64,8 %	42,3 %
Sum	8,00	4,50	1,53	100,0 %	
Number of potential suppliers					
Desirable	1,00	0,50	0,33	16,4 %	1,6 %
Essential	2,00	1,00	0,50	29,7 %	2,9 %
Vital	3,00	2,00	1,00	53,9 %	5,2 %
Sum	6,00	3,50	1,83	100,0 %	
Availability of technical specifications					
Desirable	1,00	0,50	0,33	16,4 %	4,1 %
Essential	2,00	1,00	0,50	29,7 %	7,5 %
Vital	3,00	2,00	1,00	53,9 %	13,5 %
Sum	6,00	3,50	1,83	100,0 %	

Table 11: PCMs for attributes alternatives, with normalised eigenvalues and composite weights

The table above shows the results of the pairwise comparison of alternatives. The process of finding the normalised eigenvector is here done in one step. The estimated CR of the matrix is .003, .008 and .008 for the upper, the middle and the lower matrix, respectively. See table 12 for the complete consistency matrix. New to this matrix is the composite weights, as explained in section XX on AHP. This is simply the product of the attribute and alternative eigenvalue, providing us the true priority of the specific attributes alternatives. The composite weights are then used for calculating the VED boundary values, which essentially is the ultimate goal of this AHP.

Consistency matrix for alternatives comparison	Attribute alternatives			Weighted Sum	Consistency Vector
	Desirable	Essential	Vital		
Replenishment lead time					
Desirable	0,12	0,11	0,13	0,37	3,00
Essential	0,24	0,23	0,22	0,69	3,00
Vital	0,61	0,69	0,65	1,95	3,01
Sum	0,98	1,03	0,99	3,01	
Number of potential suppliers					
Desirable	0,16	0,15	0,18	0,49	3,00
Essential	0,33	0,30	0,27	0,89	3,01
Vital	0,49	0,59	0,54	1,62	3,01
Sum	0,98	1,04	0,99	3,01	
Availability of technical specifications					
Desirable	0,16	0,15	0,18	0,49	3,00
Essential	0,33	0,30	0,27	0,89	3,01
Vital	0,49	0,59	0,54	1,62	3,01
Sum	0,98	1,04	0,99	3,01	

Table 12: Consistency matrix for alternatives comparison

In our classification process, we chose to use the following logic for deciding on numerical limits for each VED group in terms of spare part logistics characteristics: a) Spare parts that score the same VED rank on all attributes will naturally be assigned the same rank. Spare parts that rank as Vital on all attributes will be given the rank vital. The same for Essential and desirable. This is a logical assessment as a spare part with long replenishment lead times, few potential suppliers, and non-availability of the technical specifications can intuitively be classified as vital for logistics characteristics. Similarly, low lead times, several potential suppliers and available technical specifications are associated with desirable logistics characteristics.

b) When the lead time is reasonably low, i.e. desirable, and the availability of technical specification is high, i.e. desirable, but the number of suppliers scores as essential, the spare part will be classified as desirable. That is, even with a higher risk in terms of the number of potential suppliers that can deliver, the spare part will be deemed as having desirable characteristics in terms of logistics. This is mainly because we consider the other two criteria attributes as more important. Especially as the case company, and similar companies, usually have close agreements with the different suppliers, indicating that finding the relevant suppliers will most likely not be a problem. However, this is merely our assessment of the situation made for the sake of the framework development, and maintenance or logistics personnel at the case company might think differently.

This combination of desirable lead times, essential level of suppliers and desirable specifications availability represents the upper limit of the Desirable spare parts class in terms of logistics. This means that the sum of the

respective composite weights will provide us with the numerical value of the boundary limit.

Desirable, upper limit = $0.080 + 0.029 + 0.041 = 0.149$

Class	Total composite weights
Vital	≥ 0.47
Essential	<0.14 and >0.47
Desirable	≤ 0.14

Table 13: VED boundary values for classification of logistics characteristics

c) In cases with a Vital score on replenishment lead time, i.e. four months or higher, the spare part is considered vital in logistics independent of the other two criteria. This is due to our high ranking of the importance of the criteria on replenishment lead time in terms of logistics. Again, other professionals might think differently. The combination of vital lead time, desirable number of suppliers, and desirable availability of technical specifications creates the lower boundary condition for the vital class in terms of logistics

Vital, lower limit = $0.423 + 0.016 + 0.041 = 0.480$

d) As a result of the logic and summation of composite weights above, we end up with the boundary values for the VED classification provided in table 13. These numerical limits of each class are essentially the ultimate goal of the AHP. Now it is easy to calculate a total composite weight for each spare part simply by summing their different VED rankings with their respective composite weights, and then comparing this sum with the composite weight limits provided in table 13. We will then have a score for the logistics criterion of that spare part which will be used in the decision tree during the next step of the classification framework.

4.5 Decision Tree

As we can see from our decision tree in figure 22, our selected classification criteria provide us with four decision nodes; equipment criticality, probability of failure, logistics characteristics and maintenance type.

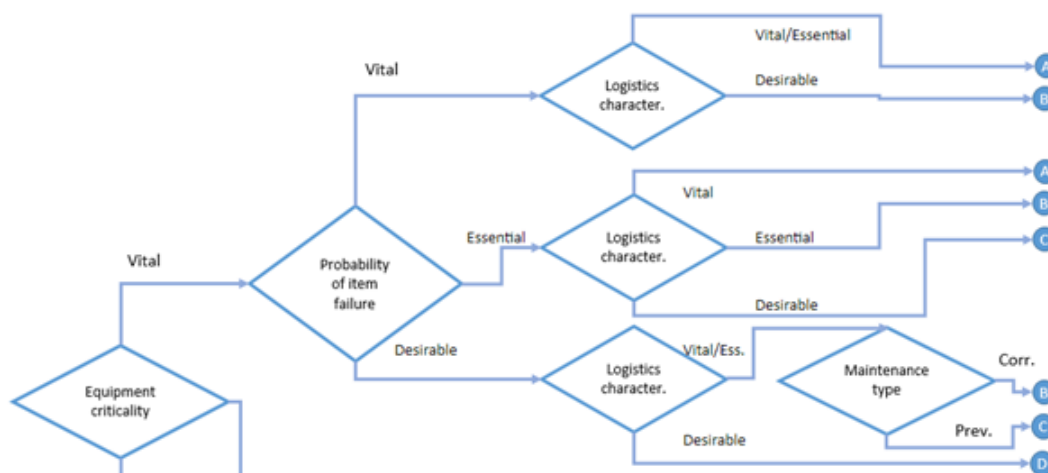

Figure 22: Snippet from decision tree for criticality classification developed by (Molenaers et al., 2012)

The decision nodes refer to the classification criteria selected in step two of the framework, and form the selection

procedure that will be used to classify specific spare parts into groups of A, B, C and D. The level A items are the most critical spare parts, B is a little less critical, and so it continues down to D, being items of low criticality. The decision path of the diagram is organised based on the outcome of each criteria alternative. That is, the VED classification provided in the previous steps. If we for instance take a look at the criterion “Equipment criticality”. Depending on the (already existing) criticality rank of the main equipment of the spare part, the spare part will get a VED classification. So if the equipment has a level 6 criticality, then the spare part will be ranked as essential. The decision path will then be to follow the arc “Essential” from this node, “Equipment criticality”, to the next node “, Probability of failure”. The same procedure is repeated for each node until we arrive at the bottom level illustrated with the classes described above; A, B, C and D. This will be the ultimate criticality class for the specific spare part, establishing the foundation for spare part strategy development.

There are two more aspects to keep in mind regarding the decision tree. Firstly, the decision node for Logistics characteristics, consisting of attributes “Replenishment lead time”, “Number of potential suppliers”, and “Availability of technical specifications”, is to be based on the VED boundary values in table 13, developed in the previous step using AHP. This means that we simply need to look at this table and compare it with the spare parts VED characteristics to get the decision path, i.e. the overall VED classification of the specific spare parts logistics characteristics. The other aspect to consider is using the criterion “Maintenance type”. As we can see from the decision tree, this criterion is only used in certain situations. To be precise, only used for situations where the probability of failure is classified as desirable, and logistics characteristics are considered vital/essential. The logic behind this classification criterion is that equipment (and their spare parts) subject to preventive/predictive maintenance (PM/PdM) is monitored and regularly controlled, and will probably therefore not only have a lower probability of failure, but also a clearer overview of its spare parts needs and consumption (Molenaers et al., 2012). As a result, in terms of spare parts strategy, such items will have a lower criticality. This is incorporated in the decision tree in the way items subject to corrective maintenance policy will be classified as more critical than those subject to PM/PdM. However, this is a bit conflicting with the general maintenance and reliability idea of criticality, as it is the most critical equipment subject to preventive maintenance in the first place. But then again, we are including the criticality level of the equipment as our most important classification criterion, meaning that this will be accounted for in the classification regardless. Nevertheless, an item subject to PM/PdM should be classified as less critical in terms of spare parts management unless one still encounters unexpected failures requiring corrective maintenance as well, hence its use in the decision diagram. However, the criterion is not given a significant priority as it is only used at the lowest decision tree level in a few cases to differentiate B-class items from C-class items. For the cases where the criterion is not used, the logic is that based on the other classification criteria, one can already have a clear indication of the criticality of the item.

4.6 Classify Spare Parts Into Groups

The last step of the classification part of the framework is actually to classify the specific spare parts into their groups. Based on the different decision paths and resulting spare parts classes in the decision diagram, we can describe the overall characteristics of each class. Following all the different paths and their resulting spare parts classes reveals the following:

A - High priority spare parts

The A-class spare parts are the most critical spares. These parts hold features that are deemed critical in terms of process and control. In the decision tree, this is manifested in the decision paths being guided by the rank of vital or essential. As a result, only three complete decision paths result in A-class spare parts classifications.

- Equipment criticality is either deemed as vital or essential: unavailability of the spare parts upon item failure has severe consequences/effects on production
- Probability of failure is either vital or essential: items are characterised by high failure rates, increasing the need for high availability
- Logistics characteristics are either deemed as vital or essential: the control criticality/availability risk for the items is high, meaning that the process of replenishing the spare parts is strenuous, for instance, because of long lead times

B - Medium priority spare parts

B classes can occur as several combinations of vital and essential criteria. As a rule of thumb, B-class spare parts are always ranked as vital or essential on at least two decision criteria. In some special cases, when uncertainty arises on whether is to be classified as class B or class C items, the type of maintenance strategy is used as decision criteria. B-class spare parts are either characterised as one of the following scenarios:

(i) Spare part is part of a *vital* system and is either;

- subject to high failure rates, but low availability risk, or
- subject to medium failure rates and medium availability risk, or
- subject to low failure rates, has a high/medium availability risk and is subject to corrective maintenance

(ii) Spare part is part of a *essential* system and is either;

- subject to high failure rates and medium/low availability risk, or
- subject to medium failure rates and high/medium availability risk, or
- subject to low failure rates, but high/medium availability risk, and is subject to corrective maintenance

(iii) Spare part is part of a *desirable* system, poses high/medium failure rates, and has a high/medium availability risk

C - Low priority spare parts

Similar to B-class spare parts, the C-class spares are characterised by a variety of combinations of different criteria rankings but are subject to more desirable decision outcomes. Also similar to B-class, in cases of uncertainty between B or C, i.e. in cases with low failure rates and high/medium availability risk, the maintenance strategy is used as the decision variable. However, C-class items are subject to preventive maintenance, with the logic described in section XX. As a result, the items are either characterised as one of the following scenarios:

(i) Spare part is part of a *vital* system and is either;

- subject to medium failure rates and low availability risk, or
- subject to low failure rates, has a high/medium availability risk and is subject to preventive maintenance

(ii) Spare part is part of a *essential* system, and is either;

- subject to medium failure rates and low availability risk, or
- subject to low failure rates, but high/medium availability risk, and is subject to preventive maintenance

(iii) Spare part is part of a desirable (low critical) system, poses high/medium failure rates, and has a low availability risk

D - “No” priority spare parts

Similar to A-class spare parts, D-class spares is a rare outcome of the decision tree, with only three occurrences. D-class spare parts are characterised by desirable spare parts features, where at least two out of the three main criteria are ranked as desirable. D-class items only occur in the following situations:

- Spare part is part of a vital system, but both failure rates and availability risk are low
- Spare part is part of an essential system, but both failure rates and availability risk are low availability risk, and are subject to preventive maintenance
- Spare part is part of a desirable system, and failure rates are low

In the latter case, when equipment criticality and probability of failure are low, the respective spare parts are considered D-class items independent of how they rank on logistics characteristics or the maintenance strategy.

4.7 Inventory Management Policy Matrix

This final step of the framework is not a part of the actual analysis done in this thesis, but is rather included for the purpose of highlighting the spare part strategy development processes as a natural next phase after completing the classification. The MASTA-model (Teixeira et al., 2018b), being an inspiration for the thesis spare part classification structure, finalises its analysis by introducing the Inventory Management Policy (IMP) matrix, a handy and easy tool for deciding on spare parts strategy. The matrix proposes potential well-established inventory policies alongside the row items, and the spare part classes as the column items and marks out the potential matches between class and strategy inside the matrix elements.

Inventory policy	Spare part classification groups			
	A	B	C	D
No stock policy			x	x
Single-item policy		x	x	x
Just-in-time policy		x	x	
Multi-item inventory	x			

Table 14: The IMP matrix with established spare part classes developed by (Braglia et al., 2004)

The thesis will not go into analysing spare parts strategies. However, a short description of each inventory management policy proposed in table 14, as well as a comparison with the spare part class descriptions in the previous subsection, is provided. As we can observe in the table, the matrix proposes four different inventory policies based on classification group; *no stock*, *single-item policy*, *just-in-time policy* and *multi-item inventory*.

- Multi-item policy
The multi-item inventory policies imply stocking more than one spare part unit. Such inventory strategies are usually combined with the use of different control parameters on when to order more parts (also

known as reorder point), how much safety stock to carry, and the batch size of each order. This is a more comprehensive spare part strategy and is potentially a good fit for the A-class items, characterised as being part of highly critical systems with a high probability of failure and having high availability risk. It could potentially also be an effective strategy for B-class items in cases where availability risk and failure rates are an issue.

- **Single-item policy**

Single-item spare part strategy implies that one carries only one piece of the spare unit on stock. Such a strategy could potentially be a good match for both B, C and D classes, depending on the specific spare part situation. Moreover, the stocking of only one piece implies that either availability risk, i.e. the easiness of replenishment, or the failure rate is reasonably low. It could also imply that the consequences of not having the spare part when needed are not critical.

- **Just-in-time policy**

Just-in-time inventory policies are well-known in the lean management and supply chain fields and emphasise supplier integration and its effect on delivery reliability. As the name states, the method implies that the order arrives when it is needed. For spare parts management, this means that we don't really stock any extra unit(s) of spares but order as soon as the spare part is needed, thereby eliminating the use of inventory and holding costs. However, the strategy is reliant on the supplier's capabilities in terms of providing low lead times with reliable delivery capacity and precision. Hence, the strategy is a good fit for spare parts classes characterised by low delivery lead times and low availability risk in general. Typically, B and C class spare parts are characterised by the features just mentioned. Equipment criticality should not be of the vital sort as the inventory policy increase the risk for unavailability of the spare part when needed.

- **No stock**

No-stock policies are used for less important spare parts where the unavailability of the item is a conscious decision. That is, if the carrying and holding cost of having it stored exceeds the gains of its availability when needed, it is simply not cost-efficient to stock it. No-stock policies would typically be a good fit for D-class spare parts and potentially C-class as well if the characteristics of criticality, logistics and failure rates allow for it.

Other factors that influence the choice of spare part strategy, such as where to store it and lead time from storage to production facility, should also be emphasised in the strategy development process.

4.8 Case Study

In this section, we will apply the multi-criteria classification framework to real-life cases from the case company production facilities. Here we will demonstrate how the analysis continues after the framework is established. Three main pieces of equipment at the case company production facilities are analysed; a centrifugal pump, a manual gate valve, and an electric motor (DC). Only the centrifugal pump will be covered here in the analysis chapter. The other two can be found in appendix A.

4.8.1 Systems Analysis

Similar to the system analysis example on the electric motor provided in section 4.1, the original drawings and other technical specifications of the centrifugal pump will not be included in the report as it is considered sensitive information. However, a generic drawing of a centrifugal pump is provided.

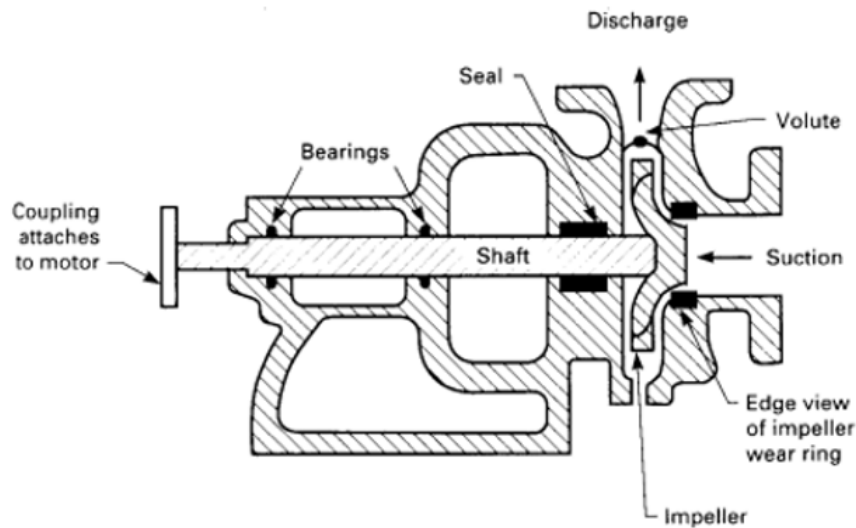

Figure 23: Assembly drawing of a general centrifugal pump (Wordpress.com, n.d.)

The data and documentation used for the systems analysis of the pump are gathered from internal CMMS and an internal documentation system. These data include assembly drawings with BOM, vendor-specific data on maintenance procedure and SPIR, datasheets, process diagrams such as P&IDs and similar, technical and functional hierarchies, as well as MRP data from the CMMS. The results is summarised in table 15, 16 and 17. The gathered data is structured around the chosen classification criteria and attributes. See section 4.1 for a description of similar tables.

System summary	
Functional location:	Trip tank pump
Equipment:	Centrifugal pump
Criticality:	8
Maintenance type :	Preventive maintenance (PM)
Technical specification:	High
OREDA MTTF (years):	0.04

Table 15: Centrifugal pump, general information

Equipment: Centrifugal pump		
Material nr.	Material description	Total installed
1	Casing, 4x3x13"	1
2	Impeller, 4x3x9 1/2"	1
3	Gasket, fluid end	1
4	Cover, stuffing box	1
5	Gland assy	1
6	Seal, Mechanical	1
7	Shaft	1
8	Shaft sleeve assembly	1
9	Bearing, inboard	1
10	Bearing, outboard	1
11	Casing gasket	1

Table 16: Spare parts BOM for the centrifugal pump

Material nr.	Material description	Equipment criticality	Prob. of failure*	Lead time**	#Suppliers	Techn. specification	Maintenance type
1	Casing, 4x3x13"	8	1.8	2	Several	High	PM
2	Impeller, 4x3x9 1/2"	8	9.3	2	Several	Medium	PM
3	Gasket, fluid end	8	2.1	4	Several	Medium	PM
4	Cover, stuffing box	8	1.8	4	Several	Medium	PM
5	Gland assy	8	1.6	12	Medium	Limited	PM
6	Seal, Mechanical	8	0.2	4	Several	High	PM
7	Shaft	8	5.0	14	Medium	High	PM
8	Shaft sleeve assembly	8	5.0	14	Medium	Limited	PM
9	Bearing, inboard	8	5.3	2	Medium	High	PM
10	Bearing, outboard	8	5.3	2	Medium	High	PM
11	Casing gasket	8	1.8	4	Several	Limited	PM

Table 17: Centrifugal pump, results and data from system analysis

4.8.2 VED Classification

The next step in the analysis of the centrifugal pump is to classify the data based on the VED framework. See table 18 below. This is done by simply comparing the data with the VED classification which was established in the third step of the framework development process (section 4.3).

Material nr.	Material description	Equip. criticality	Prob. of failure	Lead time	#Suppliers	Techn. specification	Maintenance type
1	Casing, 4x3x13"	Vital	Essential	Desirable	Desirable	Desirable	PM
2	Impeller, 4x3x9 1/2"	Vital	Desirable	Desirable	Desirable	Essential	PM
3	Gasket, fluid end	Vital	Essential	Essential	Desirable	Essential	PM
4	Cover, stuffing box	Vital	Essential	Essential	Desirable	Essential	PM
5	Gland assy	Vital	Essential	Vital	Essential	Vital	PM
6	Seal, Mechanical	Vital	Vital	Essential	Desirable	Desirable	PM
7	Shaft	Vital	Desirable	Vital	Essential	Desirable	PM
8	Shaft sleeve assembly	Vital	Desirable	Vital	Essential	Vital	PM
9	Bearing, inboard	Vital	Desirable	Desirable	Essential	Desirable	PM
10	Bearing, outboard	Vital	Desirable	Desirable	Essential	Desirable	PM
11	Casing gasket	Vital	Essential	Essential	Desirable	Vital	PM

Table 18: VED-classification of data on centrifugal pump characteristics

4.8.3 AHP for Logistics Characteristics

As the data is VED classified, the framework continues by aggregating the three logistical attributes "Number of potential suppliers", "Replenishment lead time", and "Availability of technical specification" into an overall rank for the logistics characteristics. Here the previously established AHP framework comes into play. In this step, we compare the different VED-classified data for the three attributes found in table 18 above with the respective composite weights in table ???. This is done automatically in the excel tool. For instance, observing column

”Lead time” in table 18, we can see that some parts is classified as ”Essential”, some as ”Desirable”, and others as ”Vital”. If we then look up these values in table ?? for the same attribute, i.e. ”Replenishment lead time”, we find their respective composite weight. The sum of all three attributes’ composite weights is then compared we the established VED boundary values in table 13 to find the overall VED ranking of the logistics characteristics of that specific spare part. See column ”Logistics character.” in table 19 below.

Material nr.	Material description	Lead time	#Suppliers	Techn. specification	Total composite weight	Logistics character.
1	Casing, 4x3x13"	0.0798	0.0157	0.0411	0.1366	Desirable
2	Impeller, 4x3x9 1/2"	0.0798	0.0157	0.0746	0.1701	Essential
3	Gasket, fluid end	0.1501	0.0157	0.0746	0.2404	Essential
4	Cover, stuffing box	0.1501	0.0157	0.0746	0.2404	Essential
5	Gland assy	0.4231	0.0285	0.1353	0.5869	Vital
6	Seal, Mechanical	0.1501	0.0157	0.0411	0.2069	Essential
7	Shaft	0.4231	0.0285	0.0411	0.4928	Vital
8	Shaft sleeve assembly	0.4231	0.0285	0.1353	0.5869	Vital
9	Bearing, inboard	0.0798	0.0285	0.0411	0.1494	Desirable
10	Bearing, outboard	0.0798	0.0285	0.0411	0.1494	Desirable
11	Casing gasket	0.1501	0.0157	0.1353	0.3011	Essential

Table 19: AHP applied on logistics characteristics of the centrifugal pump

4.8.4 Decision Diagram for Overall Criticality Classification

Now we have established VED classes for all chosen spare parts classification criteria alternatives. The final step is to use these as decision elements in the decision tree in appendix C. Following the different decision paths provide us with the criticality classes seen in column ”Spare part classes” in table 20. The recommended stock policy is presented in the rightmost column of the same table. This assessment is based on the IMP matrix provided in table 14. However, as stated in section 4.7, this is not based on an analysis of spare parts strategy but is merely included to highlight the strategy development processes as a natural next step, and how such a selection process might look.

Material nr.	Material description	Equip. criticality	Prob. of failure	Logistics character.	Maintenance type	Spare part class	Stock policy
1	Casing, 4x3x13"	Vital	Essential	Desirable	PM	C	Just-in-time
2	Impeller, 4x3x9 1/2"	Vital	Desirable	Essential	PM	B	Single-item stock
3	Gasket, fluid end	Vital	Essential	Essential	PM	B	Single-item stock
4	Cover, stuffing box	Vital	Essential	Essential	PM	B	Single-item stock
5	Gland assy	Vital	Essential	Vital	PM	A	Multi-item stock
6	Seal, Mechanical	Vital	Vital	Essential	PM	A	Multi-item stock
7	Shaft	Vital	Desirable	Vital	PM	B	Single-item stock
8	Shaft sleeve assembly	Vital	Desirable	Vital	PM	B	Single-item stock
9	Bearing, inboard	Vital	Desirable	Desirable	PM	D	No stock
10	Bearing, outboard	Vital	Desirable	Desirable	PM	D	No stock
11	Casing gasket	Vital	Essential	Essential	PM	B	Single-item stock

Table 20: Total VED classification, spare part classes and stock policy

That completes the analysis chapter. As stated when introducing the chapter, the framework and analysis may be divided into two main phases: processes and analysis concerned with developing the framework and the application of the developed framework. The idea is that the framework should be flexible and customisable depending on the specific spare parts situation. It is up to the assessors, i.e. the experts and specialists, to decide whether to use an existing framework version on a particular spare part or develop a new version. That is, doing all the steps concerning criteria selection, VED, AHP and decision diagrams again. Such an assessment should be based on the extent to which the specific spare parts differ from other previously analysed spare parts in terms of their characteristics. This essentially implies that there will be two levels of systems analysis. One higher-level

systems analysis to determine whether to use an existing framework version and one lower-level analysis on the specific spare part when applying the established framework. In our analysis, we have used only one framework version for all three spare part cases as the procedure of some framework steps is quite time-consuming. One possible solution for this issue could be to use already existing spare part groups and categorise as a basis for deciding on the framework. For instance, one could develop different framework templates based on spare part type (valve, pump, motor) or category (capital, operational, consumable), where each framework template is customised based on group/category characteristics.

5 Discussion

The framework developed in the previous chapter proposes a method for establishing precise criticality classes for each spare part of an equipment. It classifies the spares into four criticality classes based on their criticality ranking in terms of equipment criticality, probability of failure, logistics characteristics, and in some cases the type of maintenance applied. Three real-life cases have been analysed to demonstrate the framework; a vital centrifugal pump, an essential electric motor and a desirable gate valve. Referring to the case study in section 4.8, the spare parts of the high-criticality centrifugal pump have been classified using the framework. Out of the 11 spares, two of them are classified with A-level criticality, six spares with B-level, one C-level and two D-levels. The majority of spares have adopted a lower criticality rank than the main equipment due to more desirable characteristics in terms of availability risk and/or probability of failure.

This chapter will discuss the analysis and its. It is mainly divided into a discussion on the overall model performance and applicability compared to current practices. It then goes on to discuss the impact of different model features on the model performance, including the repercussions of excluded features that may have improved the applicability and performance of the framework.

5.1 Framework Performance and Applicability

To validate the framework performance, an analysis of how the classification results perform compared to current practices is needed. This could be done by executing a smaller pilot project to test and verify classification results. One could calculate potential savings in terms of reduced spare parts inventory and fewer resources spent on spare parts management. It is then important to cover all types of costs with a total life cycle perspective in mind. Another important aspect here is to consider the shortage costs as well. It is desired for the classification framework to help in reducing spare part holdings as much as possible, but not at the cost of availability resulting in expensive shortage and production loss. However, reliable measurements of such shortage cost estimates are not easy to develop. A simple count of occurrences where needed spare parts are unavailable is also a good measurement of the framework performance. High levels of unavailability would indicate that the framework is too aggressive, reducing inventory too much, while high inventory levels, low turnover rates and obsolescence indicate that the framework is too cautious.

Similar research projects and case studies in the field of multi-criteria spare parts classification have been made, and their findings are reported. Nagarur, Baid, et al. (1994) used a classification framework based on supplier criticality and part value, resulting in four spare part classes. The implementation resulted in inventory cost reduction. A. A. Syntetos et al. (2009) in their case study at an electronics manufacturer found their classification method to result in improved order fill rate and significantly reduced inventory cost. Syntetos et al. (2010), in their case study of an industrial valves wholesaler, found inventory cost savings of about 40%, as well as an aggressive write-off strategy for obsolete items. Another case study provided by Bacchetti, Plebani, et al. (2010) developed a simulation model for estimating the potential savings of implementing their MCIC model. The simulation results indicated significant cost reductions with an average of about 20%, as well as being able to exceed targeted service levels. However, simulations and estimates come with great uncertainties and must only be viewed as estimates. In addition, the authors have recognised limitations and assumptions that may affect the

results.

Another method of validating framework performance and applicability is having experts and specialists verify the framework classification outputs. The assessors must then be familiar (and agree) with the fundamentals of multi-criteria classification, as well as the chosen classification criteria and other important decisions made, and then give their opinion on whether they agree with the classification or not. One can then develop a ratio of performance as a percentage of correct spare part classes compared to the expert opinion.

The framework results are not validated in this thesis as such a scope as described above would be time and resource-consuming for both the authors and the case companies. However, several attempts to implement similar frameworks are executed and described in the literature. For instance, Molenaers et al. (2012) in their research on multi-criteria spare parts classification, a similar classification framework is implemented in a pilot project. Maintenance and asset managers from three different plants was selected to test the framework in terms of correctness, reliability, functionality and user-friendliness. This framework tool was also excel-based, using drop-down lists and tables. In one of the pilot plants, 2685 *business specific* spare parts (in this case, not standard spare parts and designated for one or two plants) were tested using the framework. Two maintenance managers, one involved in the project and one not, then manually evaluated the same assortment in the context of item criticality. The pilot results indicated a highly accurate classification framework, where 95,4% of the total classified spare parts using the framework corresponded with the the classification provided by the experts. In 4,6% of the cases, the expert gave a higher criticality rank than the framewor. Howeverr, this was mainly in special spare part cases, where specific requirements in terms of functionality, safety, repair time and lead time were needed. Furthermore, the framework was found to be useful and objective in classifying spare parts. Similar pilot projects could potentially be executed for Moreld Apply's clients to test and verify framework performance and applicability. An important aspect to note from this project is that they first had an initial phase concerning feedback and optimisation of the framework. Such a procedure would also be appropriate in the testing of this thesis framework, as decisions concerning VED, AHP and decision tree should be calibrated based on similar feedback and optimisation processes.

5.1.1 Reliability and validity of results

Regarding the reliability and validity of the thesis' specific results, we again need to emphasise that the results are a consequence of decisions made by us. This is for instance decision in the VED classification where we have decided that a failure rate of more than one time a year is deemed as "vital" and that a replenishment lead time of fewer than 15 days is "desirable". Such decisions will affect the framework results, meaning that a framework version modified and calibrated by company experts might yield different outcomes. However, although such characteristics may vary from sector to sector and between companies and plants, these decisions are made based on literature review and company interviews, and similar results would be likely.

Firstly, it is important to discuss the specific spare parts classes as outcomes of the framework. Referring to the case study provided in section 4.8, and specifically table 15 and table 20, we can see a high-criticality equipment and its respective spare part classes proposed by the framework. Among the 11 spare parts of the centrifugal pump, six of them are classified with a B-level criticality. The remaining five spare parts consist of two A-class spare parts, one C-class, and two D-classes. The first and most obvious observation is that the main body of

spares is classified as B, meaning with a medium criticality rank. This is high-criticality level equipment, i.e. ranked as vital, indicating that most of its spares are proposed to a lower criticality level due to more desirable characteristics in terms of availability risk or probability of failure, or both. Compared to current practices, where all spares are adopted the same criticality level as the equipment, the reduction of spare part criticality could result in potential savings as they might be given less managerial attention and less resource-demanding stocking strategies. Whether or not the degrading makes sense must be evaluated by the company experts.

Furthermore, this tendency of the classification outputs leaning toward the middle-criticality classes (B and C) seem to be true for all three spare part cases analysed in the case studies (see case studies in appendix A as well). As each case is based on one of the three different equipment criticality classes desirable, essential and vital, the tendency seems to be true independent of the equipment criticality class, which is the most heavily weighted classification criterion. But, one can also see a tendency of the classification outputs to be skewed in the direction of the equipment criticality as well. That is, for the two other cases, the electric motor with essential equipment criticality and the manual gate valve ranked as desirable, and the majority of spare parts are classified towards the middle classes, but with a skewness towards C and D, respectively. So there seems to be a tendency of most medium criticality spare parts, with a weighting towards the equipment criticality level. However, a bigger population of spare parts cases must be tested to verify this, as well as other observations.

Secondly, and maybe more important, a validation of the extremes is needed. That is, classification outcomes where spare parts adopt a significantly different criticality classification than its main equipment. Observing the decision tree paths, it is possible that vital-criticality equipment spare parts, adopt an overall criticality rank of D, the lowest criticality rank of the framework. Similarly, it is possible that a low-criticality items, i.e. with equipment criticality level set to desirable, is adopted an overall classification of B, the second-highest criticality rank of the framework. This dynamic is also observed in the case study where two spare parts of the vital centrifugal pump were proposed a D-class criticality. This means that we have highly critical equipment with a spare part which is deemed as not critical as a result of its desirable characteristics in terms of logistical aspects and failure rate. Is this realistic?

As the decision tree currently functions, the only way for A-class spare parts to occur is when the three classification criteria; equipment criticality, probability of failure and logistics characteristics, are ranked as either (1) vital, vital and vital/essential, or (2) essential, vital and vital, respectively. This means that minor reductions in criticality of only one of these criteria might cause an overall reduction in the total criticality level of the spare part, and the A-class outcomes will be less probable. However, this is not necessarily the case for highly critical equipments and other situations where one wants to have exceptions. For some critical gear one might desire all spare parts to be classified as A-class spare parts, independent of their characteristics in terms of logistics and failure rates. With the current framework, all equipment are treated similarly, meaning that such dynamics are impossible. But, as stated in the thesis, the classification framework and its several steps are flexible if these are issued, and modifications can be made to incorporate such dynamics. One modification for this particular problem could be to develop a decision path directly from the "Equipment criticality" node to the bottom row, giving them A-class, given that some decided condition is true.

The cases described above, and similar cases, must also be evaluated by case company experts, and to what degree they occur must be verified with a bigger population of spare part classifications. If the criticality changes

from equipment level to spare parts level is considered too extreme, framework modifications could be done to ensure less "radical" classification results. For instance, the case company can modify the decision tree, and in particular, which decision paths leads to the different classification classes. One can simply change a few of the class letters (A,B,C, and D) at the most extreme cases to the nearest class closer to the original equipment criticality level, resulting in a less extreme change of criticality class. Another modification could be to introduce more classification classes, let's say E and F as well, providing more nuanced classes. However, this would also imply the need for more nuanced spare parts strategies, increasing the managerial complexity. We will come back to this in later sections concerning framework features and their impact on results.

On the other side, the reason for this deviation in equipment and spare part criticality ranks is the fact of the other classification criteria affecting on the overall item criticality. This is the main objective of using multi-criteria classification as one desires to broaden the view and incorporate several characteristics from a diverse spare parts operation. Consequently, one should expect changes in the spare parts criticality levels, which sort of was the objective to begin with. However, to what degree each of the classification criteria should affect the overall framework results are not indisputable and should be assessed when adopting the classification framework. This calls for a discussion of the framework features and their effects on framework performance and applicability.

5.1.2 Data Validity

The development of the framework requires high availability and quality of data and has a big say on the preparation of significant characteristics, different decisions, and the establishment of alternative boundary values. Therefore, it is critical to discover the availability and quality of the data sources before progressing.

It was a challenge to find correct and up-to-date item data. All decisions on the current selection of parameters and boundary values have been made after thoroughly searching different databases with internal help. Although several important characteristics were deemed difficult or impossible to collect, we decided that even a medium level of data availability still would develop a sufficient classification method. In our instance, it was noticeably complicated to find precise enough data on spare part consumption and demand patterns. Therefore, it was disregarded as a criterion despite its importance for classification. Another reason for excluding criteria is data sensitivity which further complicated the development of the parameters of the framework. It is highlighted in the literature that data availability is a serious constraint. The authors of this thesis have found that consistent data management throughout the spare parts operations on an SKU level is desirable for the best classification outcomes.

As emphasised throughout this thesis, this framework is subject to further work and improvement of the data sources could be a great place to begin. For instance, the method are currently using static OREDA failure rates as input for the probability of failure. This criterion data sources could potentially be improved by, firstly, using historical data or reliability data to estimate actual failure rates for the equipment and spare parts, and secondly, considering statistical properties such as mean and variance, to incorporate reliability of the failure rate measurement. Such mechanisms, producing a more dynamic classification framework, could be applied to several of the quantitative criteria as well. For instance, the data source for replenishment lead time uses a static planned delivery time (PDT) parameter as a basis. However, there exists data on cpdt (controlled pdt) also, making sure that the data is valid. Furthermore, one could potentially develop a measurement of the delivery

precision of the suppliers. This could be estimated in terms of mean delivery time, with the standard deviation as a measurement of the delivery reliability. Consequently, it is also recommended to start tracking and monitoring these types of data to be used for future classification frameworks.

For some instances at the case study, data might be made up by us and decided rather arbitrarily. There are two reasons for this. First, there are cases where data is either not available or not of the desired quality. Also, there are cases where different data sources pose different, or even conflicting, information. In such situations, data is adjusted by us, trying to find the most realistic solution. The second reason is twofold. One side of it is that in order to illustrate the complete functioning of the classification framework, data was manipulated so that the desired classification results occurred. This could be changing the lead time or number of potential suppliers so that the spare part appears more critical in terms of logistics characteristics. However, this was only done in a few spare parts cases where the data availability and quality already were poor. The other side of the second argument is related to either complexity or time/resource needs of obtaining the data, and that companies typically have internal procedures for such processes. For instance, when gathering data for the number of potential suppliers of a specific spare part, simple internet research was used. In addition, it was not spent much time analysing and verifying the particular suppliers. The company is likely to have control over such issues, and it was decided to not put a lot of effort into it.

OREDA

OREDA is used for estimating failure rates and there are a few decisions and assumptions to be aware of. Firstly, OREDA is based on data gathered from several oil and gas companies. The estimation methods used, with their respective assumptions, are described in the OREDA handbook. We refer the reader to these sections for further details on estimation procedures and assumptions. The second feature to notice is the time aspects of the measurements and estimations. All measurements are based on 10^6 hours of the equipment's total time in service. Consequently, as we are operating with failure rates in terms of failure per year, we need to adjust the numbers. We must first convert the numbers into time units of hours (by dividing 10^6 by the failure parameter) and then divide by 24 and 365 to scale the units from hourly units into yearly.

The second feature of the time aspect is the decision of using either calendar time or operational time. Calendar time includes all of the equipment's time in service regardless of downtime. Operational time, however, only includes the time in service when operational. Which one to choose will often depend on the specific situation and in particular, what type of items and failure modes one is interested in measuring. For instance, considering a bearing, most failure modes will occur while operational. For a vessel or other marine equipment, conversely, the external corrosion from the seawater will occur regardless of whether the equipment is in service or not. Nevertheless, as we are analysing mechanical equipment being most affected and worn down by its time in service, the operational time is used for estimating the probability of failure.

The last feature concerning the time aspects of the estimation concerns the statistical properties of the measurements. In OREDA, the estimates are provided in terms of the number of failures, lower failure rate, mean failure rate, upper failure rate and the standard deviation. A normal practice here is to use the upper failure rate, as one usually desires to be on the conservative side of the estimation. With such estimations comes great uncertainties and variabilities, and it may be smart to be on the safe side, assuming a higher failure rate than it actually is. Hence, it is decided to use the upper failure rate for estimation of the item's probability of failure.

5.2 Model Features and their impacts

During the course of the thesis and framework development, the authors had to make decisions which affected the thesis and framework results. These decisions have been noted and documented when needed throughout the thesis, and are made for the sake of the framework development. As explained in section 1.5, the thesis objective is to develop a preliminary "sketch" of a multi-criteria classification framework for the case company to further test and develop, and not specific classification results. Therefore, decisions on framework features which the case company should re-evaluate has been made. The steps and decisions concerning classification criteria selection is perhaps the most important. What spare part characteristics to include in the classification process lays the premises for how the final results. This issue boils down to the assessor's perspectives, which form the ideas and interpretations of the concept of criticality.

5.2.1 Perspectives and Criticality Definition

According to A. A. Syntetos et al. (2009), the item classification lets managers focus on the most important items and facilitates decision-making processes. However, as stated by Molenaers et al. (2012), "important items from a maintenance perspective are rather different compared to important parts from an inventory or logistics viewpoint.". The maintenance perspective is focused on criticality in terms of equipment functionality, operations and production up-time. However, the logistics department is usually more fixated on the holding costs, lead times and supplier characteristics. Similarly, the financial manager would also have different ideas towards the criticality concept, typically emphasising the item cost and maintenance budget. Nevertheless, although all parties pose conflicting objectives in the spare part classification, the connections between them is essential for efficient and productive spare parts operations. Therefore, several classification criteria should be included in the framework. Yet, most companies still utilise the simpler one-criterion classification methods, such as the ABC and FSN models.

5.2.2 Multi-criteria vs. Single-Criterion

As a consequence of the different perspectives of the rather subjective concept of criticality, several spare parts classification methods have arrived over the decades. Each with their own focuses, weaknesses and strengths. During the literature review, it became clear that for most modern business decision-making, such as spare parts classification, simply using one single criterion is insufficient to cover the complex variations in spare parts operations, and that multi-criteria decision-making should be utilised. Yet, the industry seems to be at ease with the one-criterion methods such as ABC, which emphasises the annual usage value, and FSN, which focus on material movements and demand patterns. This raises the question; are there any obstacles that hinder the adoption of multi-criteria classification models?

The single-criterion methods are usually employed because of their simplicity. Additionally, they are often focused on important characteristics such as price or material movement, making them a favourable choice for classifying spare parts. This may be a reason for not using MCIC models as these might appear as either too complex or too theoretical. Botter and Fortuin (2000), in their case study on the classification of service parts, the management of the company perceived the AHP model as too theoretical for implementation in their case study on the classification of service parts. They wanted to keep things rather simple, excluding the possibility of using

multi-criteria decision models. Such findings, combined with the fact that most case studies on MCIC emphasise the need to both reduce model complexity and provide a pragmatic approach, could make the argument that these two factors make the main causes for company management to reject the methods. That is, MCIC is either deemed as too complex and/or too theoretical to be implemented. This is also highlighted by Bacchetti, Plebani, et al. (2010) as one of their key findings in terms of MCIC implications on operations management:

From a methodological point of view, multi-criteria classification models are “richer” than a simple ABC approach. (...) Such models allow for the consideration of the specificity of a company’s environment and therefore lead to more “tailored” solutions. On the other hand of course, their adoption is not as straightforward as that associated with an ABC-type approach, increasing the managerial complexity and raising issues related to their generalisation and application in different contexts. Given the importance of SKU classification solutions for inventory management, further research into the trade-offs between various possible approaches would appear to be merited.

This was noted early in this thesis project, and in the following sections we will see how it has affected the developed classification framework.

5.2.3 Criteria Selection

The first step of the classification framework, if viewing the systems analysis step as an initial step zero, was to decide upon what criteria to use for the classification. For this, the identification of relevant spare part characteristics affecting the overall spare part criticality was essential. Based on the criticality definitions proposed by Huiskonen (2001), it was decided to define the concept of criticality from two main perspectives; process criticality and control criticality. Inspired by Molenaers et al. (2012), process criticality was further decomposed into three criteria; equipment criticality, probability of failure and maintenance type. This can be viewed as criticality from the perspective of maintenance and operations. The process criticality, however, also referred to as availability risk in this thesis, can be seen as from the perspective of logistics and inventory control, and is in the framework further characterised by one main criteria called logistics characteristics, in which are decomposed into three attributes; replenishment lead time, number of potential suppliers, and availability of technical specifications.

Decisions on which criteria to include could be subject to change, and the case company is recommended to re-evaluate these. For instance, the current classification framework does not include any criteria concerning price and consumption (although a high failure rate would indicate high consumption, this is not emphasised in this thesis), meaning that it does not cover the financial aspects, as discussed in sections above on perspectives. Price and usage rate form the basis of the well-known and widely used ABC classification method, a method that forms the current spare parts classification practices for most operators at the NCS. It argues for the inclusion of price and consumption as additional criteria for the framework. This would make a multi-criteria ABC model, which is a researched method in the literature. However, a multi-criteria ABC is in fact a form of MCIC, where the only difference between multi-criteria ABC and the thesis classification framework is the criteria on price and consumption. Nevertheless, including these ABC characteristics will affect the classification results, providing a more nuanced criteria framework and covering more managerial perspectives.

Practitioners of the framework are later free to choose other criteria and the framework will remain the same in terms of process and procedures. Such decision on criteria selection, and other situation-specific aspects, is recommended to take place using expert panels, consisting of maintenance and operations specialists (and other disciplines when desired), to cover all relevant and case-specific aspects of the spare parts and maintenance situation. In practice, when implementing such a classification framework, a thorough systems analysis should include some sort of root-cause analysis to find out the main causes of spare parts unavailability cost/shortage cost, and use results as a basis for classification criteria selection. For instance, if the analysis indicates that supplier delays are the main reason for shortage of needed spare parts, then this should be emphasised in the criteria selection process. Such analysis could be based on maintenance work order reports or other reporting systems that are included in ERP systems/CMMS.

5.2.4 Complexity vs. Simplicity

The main reason for excluding classification criteria was to reduce the model complexity. With more criteria comes more complexity. One side of this is the mathematical complexity of specific procedures such as AHP and decision diagrams, making them difficult to execute. In addition, as discussed under section 3.1.4 on AHP consistency and reliability, Saaty [AHP] recommends to limiting the number of criteria to a maximum of 7 +- 2, as too many decision criteria could affect the consistency metric for controlling AHP comparison consistency. Another aspect is the conceptual and functional complexity within the framework as more criteria are added. The more spare parts characteristics one chooses to include, the harder it is to clearly understand the logical connections between the different criteria rankings, the criteria alternatives, and the final classification output. This could potentially fuel the "the blackbox effect", a concept often used to describe algorithms and in the systems theory. The analogy describes a process with known inputs, then some unknown processes occur, and we get some outputs. The assessor does not really know what is happening behind the scenes. Such characteristics is not desired for the framework as it does not promote for implementation nor for operational simplicity. The assessors and analysts should know how the framework functions and have a clear idea of its conceptual design.

5.2.5 Degree of Nuance in Classes

Another framework feature that impacts the framework complexity and classification results is the criticality classes. For this framework only four classes is used to describe the spare part criticality; A, B, C and D. However, when deciding upon equipment criticality, several more possible criticality classes is often utilised by the O&G operators, where one typically uses somewhere around 10 different classes. Is it then reasonable to use only four for spare parts classification? Similar to the decision on how many criteria to include, this issue is essentially a trade-off between the desired nuance of the classification process and the framework complexity. Having several more possible classification classes provides the opportunity of even more tailor-made and customised spare parts strategies. But, more spare parts classes and strategies will also increase the managerial complexity of running the spare parts operations, potentially requiring more resources.

If one decides that more classification classes are needed there are several potential solutions one could try. One solution might be to develop a deeper classification within the existing A, B, C and D classes, with a focus on how the spare part is weighted with respect to the characteristics/criteria. For instance, there are several cases of B-class spare parts. This indicates that the overall criticality level is quite high in terms of at least two out of the

three characteristics; equipment/system criticality, failure rate and logistics characteristics. In order to develop a more nuanced classification, one could further classify what type of B-class there is, using the spare parts criteria weightings. For instance, if we have a B-class spare part with low equipment-criticality, low failure rate, but high availability risk, this spare part could be denoted as a B-logistics, emphasising that is the logistics characteristics that forms the criticality of that particular spare part. Similarly, a B-failure rate would indicate that these spare parts are a medium-criticality item, with most of their criticality emerging from their high probability of failure. One can then develop even more tailor-made spare part strategies based on these characteristics. For the spare part with the high availability risk, one might utilise a strategy that focus on supplier reliability, delivery capabilities and similar aspects affecting the logistical aspects of the spare part situation. For the spare part with high failure rates one could emphasise the need for safety stock or perhaps exploit its convenient logistics characteristics using a JIT-policy. Even if there is no obvious spares strategy based on the characteristics, such a denotation might clarify which strategy not to use. For instance, most would not employ a JIT-strategy for spare parts with high criticality in terms of logistics characteristics.

A similar classification strategy could be using the same kind of denotation logic but only using the equipment critically. This criterion is perhaps the most important as it describes the equipment's true criticality in terms of operation up-time and safety. Consequently, one could use the equipment criticality ranking, i.e. vital, essential and desirable, as leading criticality descriptor. The classes A, B, C and D will then function as shades of the respective descriptor. This implies that if the equipment criticality is vital, then its respective B-class spare parts are classified as Vital B-class items, distinguishing them from essential Bs and desirable Bs. This differ from the current framework where all spare classes are the same. Bs are Bs and Ds are Ds. Highlighting the equipment criticality enables for taking this into account when deciding stock policy and spare strategy.

5.2.6 Main shortcomings

One important shortcoming of the classification framework is the exclusion of some criteria. Firstly, when adopting the framework, a criterion should be developed describing the spare part's criticality in terms of its importance for the equipment's functioning. Suppose the spare part is not critical for the equipment's functioning. In that case, the easiness of its replenishment combined with its low probability of failure might argue for a lower spare part criticality level. Similarly, a spare part that is highly critical for the functioning of the equipment might not be heavily affected by the other criteria. Earlier in section 5.1.1, the potential issues of critical equipment's spare parts being significantly degraded in criticality because of other desirable characteristics was introduced, and the potential solution of developing a direct decision path from the "Equipment criticality" node to the bottom row, giving it A-class criticality, was discussed. However, a condition was needed to execute this logic as we (the framework) need to know when such situations occur. The implementation of a criterion describing the criticality of the spare part in terms of the equipment functionality could function in that condition. That is, if the equipment criticality is vital and the spare parts function is vital, then the spare part is truly vital and might adopt an A-class criticality straight away, independent of other criteria outcomes. However, such logic is only possible by incorporating the criticality of the spare part in terms of equipment functions as a classification criterion in the framework. The development of this criterion would require a thorough risk, criticality and consequence classification of each spare part with respect to equipment function. Such an analysis requires a scope beyond that of this thesis, and could potentially be subject to another master's thesis of its own.

Another missing classification criterion that might be of great importance in terms of spare part classification is the life-cycle phases of the items. This characteristic was included in the MCIC model of Bacchetti, Plebani, et al. (2010) and was in their discussion of the implications of the method on OM (Operations Management) theory and practice noted as essential for their spare part classification. Additionally, life-cycle characteristics were found to be generally not included in research on the topic, where the authors only found its use in 2 out of 25 similar research projects. This calls for further research. Anyhow, the criterion is important as it functions as a profound indicator of the equipment's health condition, in which provides information about current and future failure characteristics. Referring to the well-known bathtub curve, an item at the end of its life-cycle will typically pose higher failure rates and increased needs for spare parts. Other life-cycle curves exist and most industrial equipment are in fact usually well researched in terms of their life-cycle characteristics and failure characteristics. Another aspect of the item life-cycle is related to the decision-making process regarding the specific spare part cases. If equipment is at the end of its typical life-cycle then a question should be raised on whether to invest more in this equipment or not. Such a decision should affect the spare parts classification as one might decide to delimit, or even exclude/eliminate, the spare parts spendings for equipment that is in their disposal phases or similar. Consequently, a criterion describing the equipment/spare part life-cycle should be explored.

5.3 Other practicalities and implications

In addition to assessing the framework applicability and validity, as well as elaborating the different framework features and their impacts, a discussion of a few additional sub-objectives of the thesis should be provided. The framework flexibility raises questions regarding whether one should opt for a standardised framework or not. Also, a comparison of the developed framework with other known maintenance project execution models is needed.

5.3.1 Customisation vs. standardisation

To what degree should the framework be adjusted for each case? One desires the best possible fit between the classification framework and each spare part case, but doing the whole procedure for each piece of equipment might not be efficient. As we demonstrated in the case study, when the framework steps for criteria selection, VED classification, AHP comparison, and decision diagrams are completed, doing the actual spare part analysis is quite simple. Consequently, the potential gains from a fixed and standardised classification framework might pose great opportunities in terms of efficiency and cost reductions. Most case studies in the literature seem to be utilising this approach as the classification procedure is developed once. On the other side, adjusting the framework for the different spare parts scenarios could provide opportunities for better spare parts classifications, eventually resulting in more tailored strategies.

One possible middle-ground between framework customisation and framework standardisation could be to exploit the already existing spare part categories or groups. Here one could, for instance, use the NORSOK Z-008 categories (capital, operational, consumable) or the equipment group/type (valve, pump, motor), with their distinct characteristics in terms of spare parts operations, as a basis to develop unique framework templates specifically for the respective category or group. One could then capture the distinct variabilities in spare part situations in each set of standardised classification frameworks. For example, in section 1.2 introducing the case studies

with general spare parts data, we saw that the case company MRP data on the spare part categories capital, operational and consumable indeed holds the characteristics described by NORSOK Z-008 in section 2.4. Capital spare parts are characterised by long lead times, high prices and low usage rates. Operational with similar properties, but in the medium range, and consumables at the lower range. Such characteristics could be exploited to develop standardised framework templates. Similar patterns and tendencies might exist for equipment groups such as valves, motors and pumps as well, providing opportunities for even more customised templates.

5.3.2 When and where to use

Another sub-objective of the thesis was to discuss when in a typical maintenance lifecycle, or asset/product lifecycle, the classification framework should be applied. Naturally, the answer to this question will depend on the situation of the specific company, as well as with what life-cycle scheme the framework is compared to. Nevertheless, a logical starting point might be the famous maintenance loop, often introduced during maintenance education.

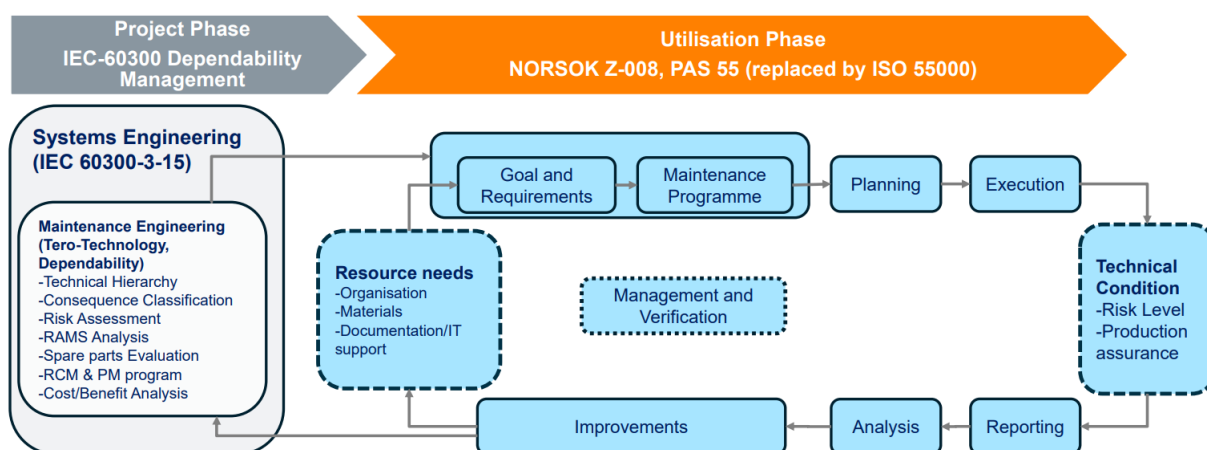

Figure 24: Maintenance lifecycle - the project phase and its connection with the utilisation phase

The left side of the maintenance loop provided in figure 24 highlights the fundamentals of a typical maintenance project and its link with the utilisation phase, i.e. the maintenance loop. The project phase is often referred to as systems or maintenance engineering, which concerns the design and development activities related to maintenance and asset management. An important concept here is dependability management, a multi-disciplined engineering field concerned with an asset's availability, reliability, dependability and supportability. In short, that is, to what degree is the asset ready for doing correct service with desired continuity and quality, and how easy is it to maintain and support it. These concepts shape the RAMS (Reliability, Availability, Maintainability and Supportability) analysis which forms the basis for dependability management. Maintenance/systems engineering is taking the design-out approach to maintenance problems, emphasising that correct dependability management starts in the design phase. As the figure illustrates, such projects' main activities are technical hierarchies, consequence clarification, risk assessment, RAMS analysis, spare parts evaluation, RCM & PM programs, and cost/benefit analysis. Therefore, it is logical to think that the classification framework could be a part of the spare parts evaluation activities. This is not only because spare parts classification is an essential aspect of spare part evaluation, but perhaps more importantly, all the abovementioned activities illustrated in figure 24 provide valuable input for developing the classification framework. Having done a thorough risk analysis, consequence

classification, and RAMS analysis could lay the foundation of all the needed data and information required to develop the framework. It might facilitate intelligent decision-making regarding framework features and other important aspects discussed throughout the thesis. Additionally, if viewing the development of the framework as the maintenance engineering project that it is, it may be clear that the thesis project falls under the project phase described in figure 24, meaning that the development of the framework could be executed similarly as indicated in the figure.

That being said, as most maintenance activities and processes may be subject to continuous improvements, as well as that changing environments might affect the classification scheme, the spare parts classification framework could also fit inside the utilisation phase on the right side of figure 24. The "Reporting" and "Analysis" activities are necessary to establish an overview of how the spare parts operations are performing, and the "Improvements" activities are needed to modify and improve the possible shortcomings. This again will function as valuable input to the "Resource needs" step, with spare parts being an essential resource for maintenance execution. For instance, if it is reported a shortage of needed spare parts, then an analysis of the framework with respect to the particular spare part should be executed. A possible finding of the analysis could, for instance, be that the replenishment lead times of that spare part are longer and less reliable than first assumed, which results in it being changed from ranked as essential to vital in terms of logistics characteristics. Consequently, the class might change from a class C to class B, and the improvement might be to use a single-item stock policy instead of just-in-time.

6 Conclusion

The authors have, through the work in this thesis, developed a classification framework tool for criticality and consequence analysis on a spare parts level. The objective was to establish precise criticality classes for each of the equipment's spare parts. It was established early on that a pragmatic approach was preferred, and the framework was therefore developed with the application on different cases from the case company in mind. The framework has utilised an MCIC method which focuses on several, often conflicting, criteria and relationships when classifying spares into groups. This is based on the literature consensus that single-criterion approaches are generally too limited to support modern business decision-making.

The framework proposes a method for classifying spares as an alternative to current classification practices, which retains the same criticality level as the main equipment for all spares. It effectively divides all spares into four criticality groups based on the impact the different criteria have and performs well in the single case testing scenarios analysed in Section 4. The results indicate that, in almost all instances, the criticality level of spares is lowered/ reduced compared to the main equipment. As emphasised in section 5.1.1, the results can look like this because all decisions on criteria, weights and VED boundaries are made by the creators of the framework. Nonetheless, these decisions have been facilitated with expert opinion and literature review, and it is therefore reasonable to assume results will be similar should the classification exercise be performed by others. The classification tool makes a substantial contribution to the difficulty of getting a quantitative solution to a somewhat subjective issue.

This thesis also introduces the idea of using an IMP matrix to establish the link between the SKU classification and inventory policies. Appropriate selection of inventory policy is highly relevant to achieve efficient inventory and maintenance management. A spare part is required when the corresponding installed part fails or is replaced preventively, and its classification is thus closely related to the maintenance policy adopted. Maintenance policies and breakdowns dictate the need for spare parts inventories and should be considered in the classification process.

One of the main discussion points in this thesis is whether the framework would be a suitable approach for the case company to adopt. Findings from literature and the different case studies confirm that multi-criteria classification should be seriously considered in the management of spare parts. Particularly in capital intensive industries due to substantial spare part inventories with a huge amount of different SKUs.

As a final remark, case studies do not necessarily offer general solutions nor give a complete depiction of the problem at hand. They attempt to illustrate the complexity involved in a decision-making process by exemplifying the actual problems to deal with. However, academics use it to explore managerial norms and the practical validity and relevance of theoretical propositions (Bacchetti and Nicola Saccani, 2012).

6.1 Recommendation

As mentioned, one of the aims was to determine whether this method would be applicable to use in real-world scenarios and then address the possible benefits from adopting the approach. With the work in this thesis, valuable findings have been reported and discussed and ultimately led to the conclusion that the framework has great potential in the classification practices in the industry. We see that the framework is already implementable for

single case scenarios such as the ones analysed in this thesis, and provides reliable results. However, it is still important to remember that the tool presented is simply a suggestion on how to improve the current spare part classification practices, and is therefore subject to further testing and development.

The recommendation is thus, it can be greatly beneficial to fully adopt the approach and should facilitate the classification and spare part management processes. An eventual full extension and application of the approach would be a dynamic tool with the ability to perform spare part classification on a much larger scale. However, as discussed in 5.2.2, simplicity and practicality are favourable attributes of classification models. It is therefore suggested to commence with a simple model, and then let data scientists and field experts to further upgrade it by increasing complexity, adding dynamic features and allowing full integration with ERP systems to produce even more accurate and reliable results. A large-scale implementation would, among other things, allow the extraction of descriptive statistics on SKUs and classification groups, providing valuable insights to important performance metrics in the classification process.

6.2 Limitations and Future Work

Referring to the conclusion and recommendation above, we do recognise that there are several limitations to our study. They can, however, be seen as natural extensions of the work described in this thesis.

We believe it is possible to use the suggested framework in single-case scenarios with the current criteria selection, but the accuracy of the model could be improved by including other important spare part characteristics as well. The decision to not include these is due to the desire to reduce the overall framework complexity, as discussed in section 5.2.4. Some were also deemed outside of scope due to time constraints and data availability. Criteria such as the part value, potential cost of obsolescence, inventory holding and ordering charges, demand pattern, commonality and repairability will most likely give a more accurate representation of the complicated nature of spare parts. These would also further improve the usefulness of the model. Especially part value and demand patterns have been named as important and commonly used when classifying spare parts (Huiskonen, 2001; Teixeira et al., 2017). Another important aspect to consider is that each spare part will have its own impact on equipment function, and therefore have unique criticality values. The presence or absence of (or access to) relevant data was a limitation in this study and played a major role in the development of the framework and its parameters.

Ideally, the proposed framework should be tested on a wider range of cases and parameters to reach even more convincing conclusions. That is because the results can then be identified as statistically significant, and confidently state that chance is not involved. Whether or not to extend the current solution and apply it on a much bigger scale is a decision that requires such significance of results. Therefore, a sensible first step would be a pilot project organised by the decision-makers themselves tests a wide range of variations in characteristics, weights and boundaries, and the sensitivity of these variations. The first phase of this type of project concerns modification, calibration and optimisation of the framework based on expert opinion and testing. The second phase is applying it to several spare part cases to increase the statistical significance level, then verifying observations and findings. The last phase involves checking whether there are actual benefits of implementing the framework or not. As discussed in 5.1, this includes calculating potential savings from reducing spare parts inventory and optimising inventory processes. Another metric is whether or not the framework reduces the costs associated

with shortage and production losses.

Bibliography

- Bacchetti, Andrea, R Plebani, et al. (2010). "Spare parts classification and inventory management: a case study". In: *Salford Business School Working Papers Series* 408.
- Bacchetti, Andrea and Nicola Saccani (2012). "Spare parts classification and demand forecasting for stock control: Investigating the gap between research and practice". In: *Omega* 40.6, pp. 722–737.
- Botter, Rene and Leonard Fortuin (2000). "Stocking strategy for service parts—a case study". In: *International Journal of Operations & Production Management*.
- Boylan, John E and Aris A Syntetos (2010). "Spare parts management: a review of forecasting research and extensions". In: *IMA journal of management mathematics* 21.3, pp. 227–237.
- Braglia, Marcello et al. (2004). "Multi-attribute classification method for spare parts inventory management". In: *Journal of quality in maintenance engineering*.
- Cavaliere, Sergio et al. (2008). "A decision-making framework for managing maintenance spare parts". In: *Production planning & control* 19.4, pp. 379–396.
- Devarajan, Divya and MS Jayamohan (2016). "Stock control in a chemical firm: combined FSN and XYZ analysis". In: *Procedia Technology* 24, pp. 562–567.
- Forge, Bonney (n.d.). *Cast Steel Gate Valves*. URL: <https://bonneyforge.com/products.php?pg=csvvalves&subpg=gate>.
- Gajpal, Prem Prakash et al. (1994). "Criticality analysis of spare parts using the analytic hierarchy process". In: *International journal of production economics* 35.1-3, pp. 293–297.
- Ghodrati, Behzad (2005). "Reliability and operating environment based spare parts planning". PhD thesis. Luleå tekniska universitet.
- Gopalakrishnan, P and AK Banerji (2013). *Maintenance and spare parts management*. PHI Learning Pvt. Ltd.
- Güvenir, H Altay and Erdal Erel (1998). "Multicriteria inventory classification using a genetic algorithm". In: *European journal of operational research* 105.1, pp. 29–37.
- Hatefi, SM et al. (2014). "Multi-criteria ABC inventory classification with mixed quantitative and qualitative criteria". In: *International Journal of Production Research* 52.3, pp. 776–786.
- Ho, William (2008). "Integrated analytic hierarchy process and its applications—A literature review". In: *European Journal of operational research* 186.1, pp. 211–228.
- Hosseini, Seyedmohsen and Abdullah Al Khaled (2019). "A hybrid ensemble and AHP approach for resilient supplier selection". In: *Journal of Intelligent Manufacturing* 30.1, pp. 207–228.
- Hu, Qiwei et al. (2018). "OR in spare parts management: A review". In: *European Journal of Operational Research* 266.2, pp. 395–414.
- Huiskonen, Janne (2001). "Maintenance spare parts logistics: Special characteristics and strategic choices". In: *International journal of production economics* 71.1-3, pp. 125–133.

- Jiang, Hongquan et al. (2019). “Classification of weld defects based on the analytical hierarchy process and Dempster–Shafer evidence theory”. In: *Journal of Intelligent Manufacturing* 30.4, pp. 2013–2024.
- Johnson, R Burke et al. (2007). “Toward a definition of mixed methods research”. In: *Journal of mixed methods research* 1.2, pp. 112–133.
- Jouni, Paakki et al. (2011). “Improving global spare parts distribution chain performance through part categorization: A case study”. In: *International Journal of Production Economics* 133.1, pp. 164–171.
- Mohsen, Ahmed and Hassan Al-Sharkawy (July 2017). “Automated Storage and Retrieval System Prototype for Small Size Products”. PhD thesis. DOI: 10.6084/m9.figshare.13799042.
- Molenaers, An et al. (2012). “Criticality classification of spare parts: A case study”. In: *International Journal of Production Economics* 140.2, pp. 570–578.
- Mouschoutzi, Maria and Stavros T Ponis (2022). “A comprehensive literature review on spare parts logistics management in the maritime industry”. In: *The Asian Journal of Shipping and Logistics*.
- Nagarur, Nagen N, Nirmal K Baid, et al. (1994). “A computer-based inventory management system for spare parts”. In: *Industrial Management & Data Systems*.
- Nguyen, Giang Huong (2014). “The Analytic Hierarchy Process: A Mathematical Model for Decision Making Problems”. In.
- NORSOK (2011). *Risk-based maintenance and consequence classification, Z-008 revision*. NORSOK Standard.
- Partovi, Fariborz Y and Jonathan Burton (1993). “Using the analytic hierarchy process for ABC analysis”. In: *International Journal of Operations & Production Management*.
- Petroleum, Norwegian (2021). *INVESTMENTS AND OPERATING COSTS*. URL: <https://www.norskpetroleum.no/en/economy/investments-operating-costs/>.
- Ramanathan, Ramakrishnan (2006). “ABC inventory classification with multiple-criteria using weighted linear optimization”. In: *Computers & operations research* 33.3, pp. 695–700.
- Ratnayake, RM Chandima (2019). “Consequence classification based spare parts evaluation and control in the petroleum industry”. In: *2019 IEEE International Conference on Industrial Engineering and Engineering Management (IEEM)*. IEEE, pp. 1204–1210.
- Rodin, Alex and Ilya Katsov (2019). *Safety stock optimization for Ship-from-Store*. URL: <https://blog.griddynamics.com/safety-stock-optimization-for-ship-from-store/>.
- Saaty, Roseanna W (1987). “The analytic hierarchy process—what it is and how it is used”. In: *Mathematical modelling* 9.3-5, pp. 161–176.
- Silva Neves, Adriano José da and Roberto Camanho (2015). “The use of AHP for IT project prioritization—a case study for oil & gas company”. In: *Procedia Computer Science* 55, pp. 1097–1105.
- Standards, Norway (2022). *NORSOK standards*. URL: <https://www.standard.no/en/sectors/energi-og-klima/petroleum/norsok-standards/#.YqiiI3ZBxD9>.

- Subramanian, Nachiappan and Ramakrishnan Ramanathan (2012). “A review of applications of Analytic Hierarchy Process in operations management”. In: *International Journal of Production Economics* 138.2, pp. 215–241.
- Swanson, Laura (2001). “Linking maintenance strategies to performance”. In: *International journal of production economics* 70.3, pp. 237–244.
- Syntetos, Aris A et al. (2009). “Demand categorisation in a European spare parts logistics network”. In: *International journal of operations & production management*.
- Teixeira, Catarina et al. (2017). “Multi-criteria classification for spare parts management: a case study”. In: *Procedia Manufacturing* 11, pp. 1560–1567.
- (2018a). “Classification methodology for spare parts management combining maintenance and logistics perspectives”. In: *Journal of Management Analytics* 5.2, pp. 116–135.
- (2018b). “Classification methodology for spare parts management combining maintenance and logistics perspectives”. In: *Journal of Management Analytics* 5.2, pp. 116–135.
- Triantaphyllou, Evangelos, Stuart H Mann, et al. (1995). “Using the analytic hierarchy process for decision making in engineering applications: some challenges”. In: *International journal of industrial engineering: applications and practice* 2.1, pp. 35–44.
- Van der Auweraer, Sarah et al. (2019). “Forecasting spare part demand with installed base information: A review”. In: *International Journal of Forecasting* 35.1, pp. 181–196.
- Wang, Wenbin and Aris A Syntetos (2011a). “Spare parts demand: Linking forecasting to equipment maintenance”. In: *Transportation Research Part E: Logistics and Transportation Review* 47.6, pp. 1194–1209.
- (2011b). “Spare parts demand: Linking forecasting to equipment maintenance”. In: *Transportation Research Part E: Logistics and Transportation Review* 47.6, pp. 1194–1209.
- Wedley, William C (1993). “Consistency prediction for incomplete AHP matrices”. In: *Mathematical and computer modelling* 17.4-5, pp. 151–161.
- Wordpress.com (n.d.). *Troubleshooting-pump*. URL: <https://troubleshootingpump.wordpress.com/centrifugal-pump-component-2/>.
- Yang, Zimin Max et al. (2008). “Maintenance scheduling in manufacturing systems based on predicted machine degradation”. In: *Journal of intelligent manufacturing* 19.1, pp. 87–98.
- Yiğit, Fatih and Şakir Esnaf (2021). “A new Fuzzy C-Means and AHP-based three-phased approach for multiple criteria ABC inventory classification”. In: *Journal of Intelligent Manufacturing* 32.6, pp. 1517–1528.
- Zavadskas, Edmundas Kazimieras and Valentinas Podvezko (2016). “Integrated determination of objective criteria weights in MCDM”. In: *International Journal of Information Technology & Decision Making* 15.02, pp. 267–283.
- Zhang, L (2014). “Multi-attribute Decision Making”. In: *Encyclopedia of Quality of Life and Well-Being Research*. Springer; Dordrecht.

Appendix

A Case studies

Results from the remaining case studies, i.e. the DC electric motor and a gate valve, will be presented in the following sections.

A.1 DC Electric Motor

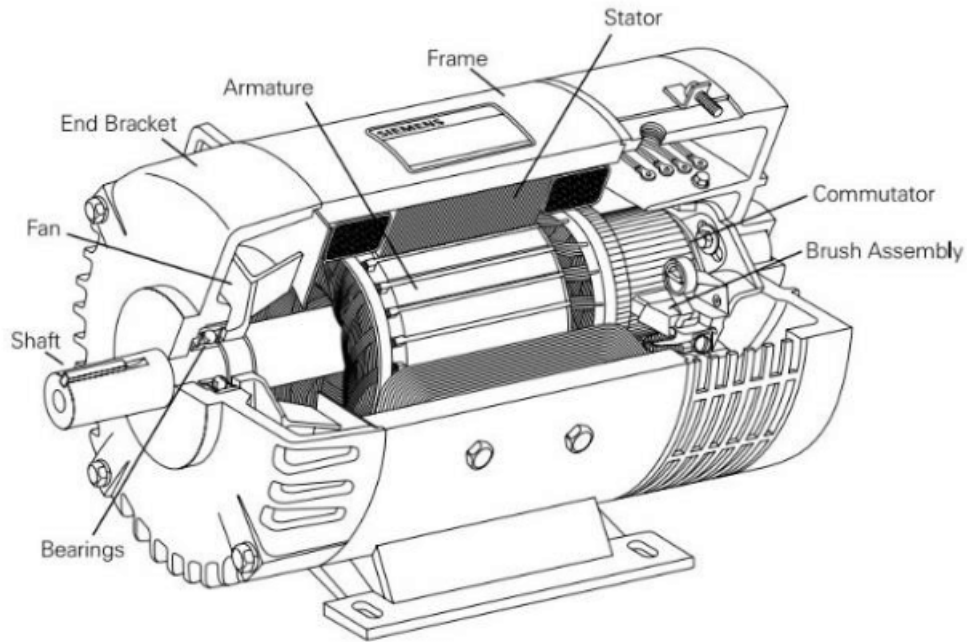

Figure 25: Assembly drawing of a general DC electric motor (Mohsen and Al-Sharkawy, 2017)

System summary	
Functional location:	Tank pump motor
Equipment:	Electric motor, DC, 690V, 60Hz
Criticality:	6
Maintenance type:	Preventive maintenance (PM)
Technical specification:	Limited
OREDA MTTF (years):	0,57
Unit price:	kr 111 476,00

Table 21: DC electric motor, general information

Equipment: Electric motor, DC, 690V, 60Hz		
Material nr	Material description	Total installed
1	Control unit	1
2	Cablng & junction box	1
3	Subunit	1
4	Thrust bearing	1
5	Insrument vibration	1
6	Radial bearing	1
7	Stator	1
8	Fan	1

Table 22: Spare parts BOM for the DC electric motor

Material nr.	Material description	Equipment criticality	Probability of failure*	Lead time**	#Suppliers	Techn. specification	Maintenance type
1	Control unit	6	5,5	18	Several	Limited	PM
2	Cablng & junction box	6	16,0	18	Several	Limited	PM
3	Subunit	6	4,3	18	Several	Limited	PM
4	Thrust bearing	6	22,8	18	Several	Limited	PM
5	Insrument vibration	6	16,0	18	Few	Limited	PM
6	Radial bearing	6	6,9	18	Several	Limited	PM
7	Stator	6	40,0	18	Medium	Limited	PM
8	Fan	6	17,7	18	Medium	Limited	PM

Table 23: DC electric motor, results and data from system analysis

* Probability of failure as MTTF in years ** Lead time in weeks

Material nr.	Material description	Equip. criticality	Prob. of failure	Lead time	#Suppliers	Techn. specification	Maintenance type
1	Control unit	Essential	Essential	Vital	Desirable	Essential	PM
2	Cablng & junction box	Essential	Desirable	Vital	Desirable	Essential	PM
3	Subunit	Essential	Essential	Vital	Desirable	Essential	PM
4	Thrust bearing	Essential	Desirable	Vital	Desirable	Essential	PM
5	Insrument vibration	Essential	Desirable	Vital	Vital	Essential	PM
6	Radial bearing	Essential	Desirable	Vital	Desirable	Essential	PM
7	Stator	Essential	Desirable	Vital	Essential	Essential	PM
8	Fan	Essential	Desirable	Vital	Essential	Essential	PM

Table 24: VED-classification of data on DC electric motor characteristics

Material nr.	Material description	Lead time	#Suppliers	Techn. specification	Total composite weight	Logistics character.
1	Control unit	0,4231	0,0157	0,0746	0,5134	Vital
2	Cablng & junction box	0,4231	0,0157	0,0746	0,5134	Vital
3	Subunit	0,4231	0,0157	0,0746	0,5134	Vital
4	Thrust bearing	0,4231	0,0157	0,0746	0,5134	Vital
5	Insrument vibration	0,4231	0,0517	0,0746	0,5495	Vital
6	Radial bearing	0,4231	0,0157	0,0746	0,5134	Vital
7	Stator	0,4231	0,0285	0,0746	0,5263	Vital
8	Fan	0,4231	0,0285	0,0746	0,5263	Vital

Table 25: AHP applied on logistics characteristics of the DC electric motor

Material nr.	Material description	Equip. criticality	Prob. of failure	Logistics character.	Maintenance type	Spare part class	Stock policy
1	Control unit	Essential	Essential	Vital	PM	B	Single-item policy
2	Cablng & junction box	Essential	Desirable	Vital	PM	C	Just-in-time
3	Subunit	Essential	Essential	Vital	PM	B	Single-item policy
4	Thrust bearing	Essential	Desirable	Vital	PM	C	Just-in-time
5	Insrument vibration	Essential	Desirable	Vital	PM	C	Just-in-time
6	Radial bearing	Essential	Desirable	Vital	PM	C	Just-in-time
7	Stator	Essential	Desirable	Vital	PM	C	Just-in-time
8	Fan	Essential	Desirable	Vital	PM	C	Just-in-time

Table 26: Total VED classification, spare part classes and stock policy

A.2 Gate valve

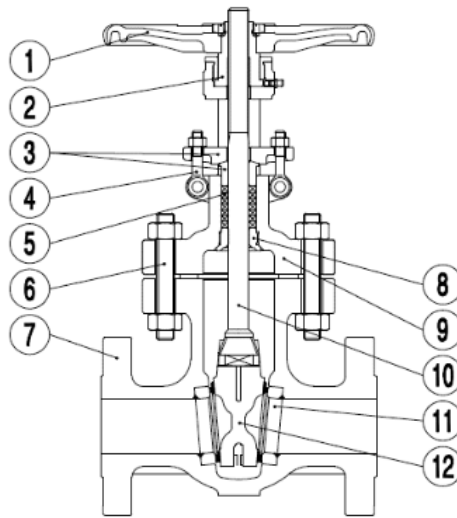

Figure 26: Assembly drawing of a general gate valve (Forge, n.d.) (numbers and items will not match with BOM provided below)

System summary	
Functional location:	Isolation valve for filter manifold
Equipment:	Gate valve
Criticality:	3
Maintenance type:	Preventive maintenance (PM)
Technical specification:	High (all needed docs)
OREDA MTTF (years):	0,14

Table 27: Gate valve, general information

Equipment: Gate valve	
Material nr	Material description
1	Seals (gaskets)
2	Seat rings
3	Subunit
4	Pilot valve
5	Intrument position
6	Bonnet
7	Seals
8	Position intrument

Table 28: Spare parts BOM for the gate valve

Material nr.	Material description	Equipment criticality	Prob. of failure*	Lead time**	#Suppliers	Techn. specification	Maintenance type
1	Seals (gaskets)	3	34,5	18	Several	High	PM
2	Seat rings	3	1,6	18	Several	High	PM
3	Subunit	3	0,6	18	Several	High	PM
4	Pilot valve	3	1,6	18	Several	High	PM
5	Intrument position	3	3,2	18	Few	High	PM
6	Bonnet	3	34,5	18	Several	High	PM
7	Seals	3	17,5	18	Medium	High	PM
8	Position intrument	3	3,2	18	Medium	High	PM

Table 29: Gate valve, results and data from system analysis

* Probability of failure as MTTF in years ** Lead time in weeks

Material nr.	Material description	Equip. criticality	Prob. of failure	Lead time	#Suppliers	Techn. specification	Maintenance type
1	Seals (gaskets)	Desirable	Desirable	Vital	Desirable	Desirable	PM
2	Seat rings	Desirable	Essential	Vital	Desirable	Desirable	PM
3	Subunit	Desirable	Vital	Vital	Desirable	Desirable	PM
4	Pilot valve	Desirable	Essential	Vital	Desirable	Desirable	PM
5	Intrument position	Desirable	Essential	Vital	Vital	Desirable	PM
6	Bonnet	Desirable	Desirable	Vital	Desirable	Desirable	PM
7	Seals	Desirable	Desirable	Vital	Essential	Desirable	PM
8	Position intrument	Desirable	Essential	Vital	Essential	Desirable	PM

Table 30: VED-classification of data for gate valve characteristics

Material nr.	Material description	Lead time	#Suppliers	Techn. specification	Total composite weight	Logistics character.
1	Seals (gaskets)	0,4231	0,0157	0,0411	0,4799	Vital
2	Seat rings	0,4231	0,0157	0,0411	0,4799	Vital
3	Subunit	0,4231	0,0157	0,0411	0,4799	Vital
4	Pilot valve	0,4231	0,0157	0,0411	0,4799	Vital
5	Intrument position	0,4231	0,0517	0,0411	0,5160	Vital
6	Bonnet	0,4231	0,0157	0,0411	0,4799	Vital
7	Seals	0,4231	0,0285	0,0411	0,4928	Vital
8	Position intrument	0,4231	0,0285	0,0411	0,4928	Vital

Table 31: AHP applied on logistics characteristics of the gate valve

Material nr.	Material description	Equip. criticality	Prob. of failure	Logistics character.	Maintenance type	Spare part class	Stock policy
1	Seals (gaskets)	Desirable	Desirable	Vital	PM	D	No stock
2	Seat rings	Desirable	Essential	Vital	PM	B	Single-item policy
3	Subunit	Desirable	Vital	Vital	PM	B	Single-item policy
4	Pilot valve	Desirable	Essential	Vital	PM	B	Single-item policy
5	Intrument position	Desirable	Essential	Vital	PM	B	Single-item policy
6	Bonnet	Desirable	Desirable	Vital	PM	D	No stock
7	Seals	Desirable	Desirable	Vital	PM	D	No stock
8	Position intrument	Desirable	Essential	Vital	PM	B	Single-item policy

Table 32: Total VED classification, spare part classes and stock policy

B Overview of Classification Process

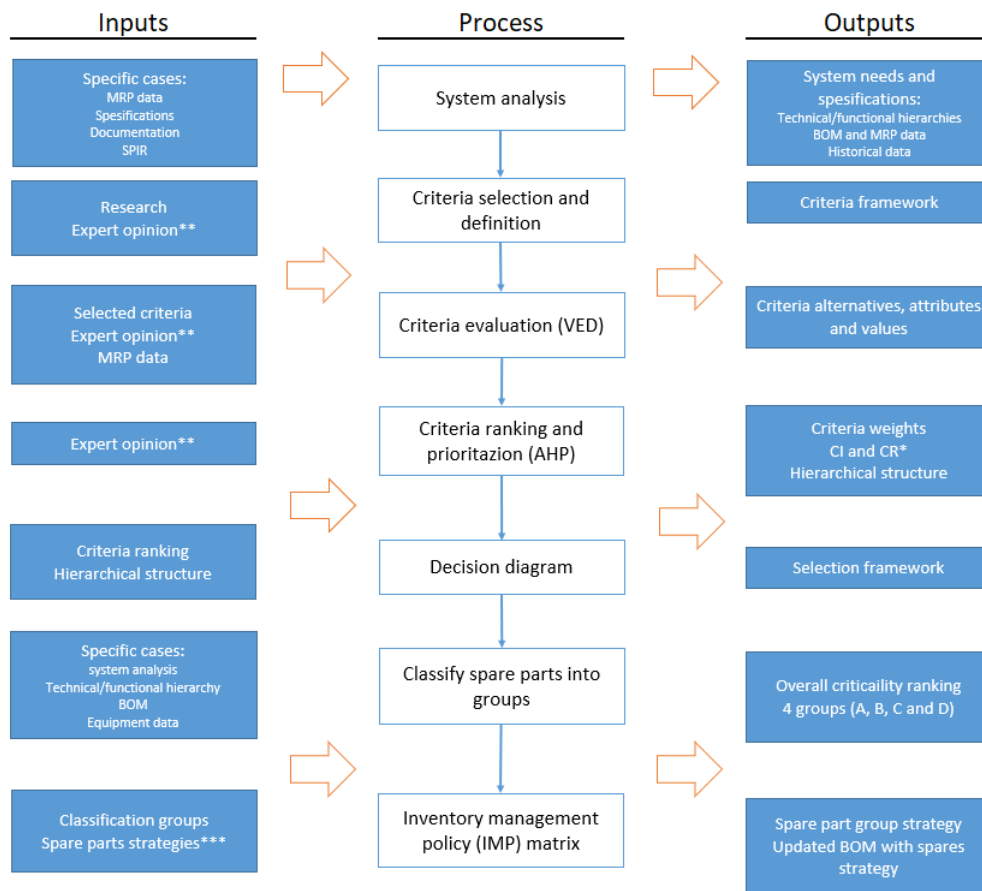
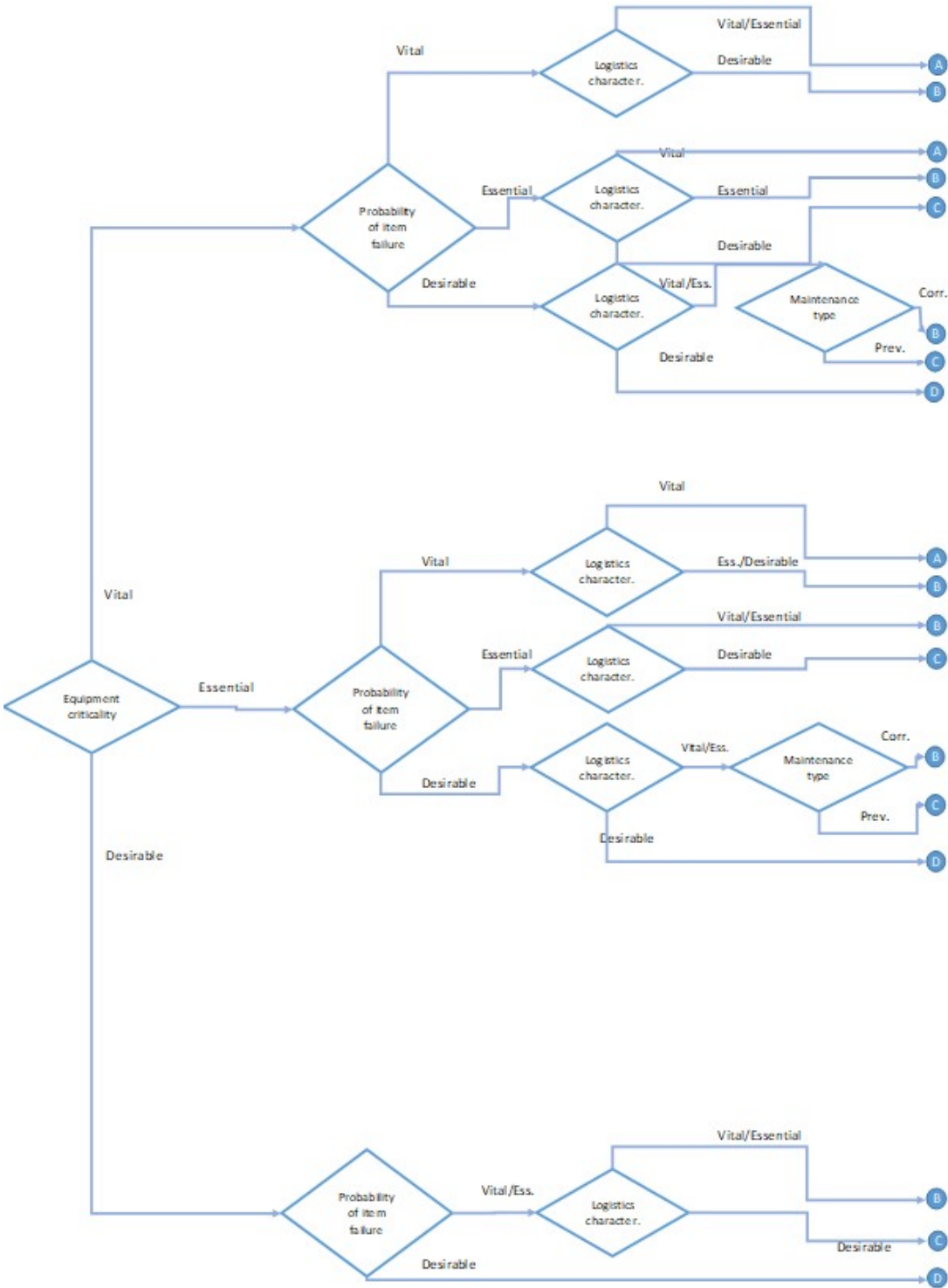

Figure 27: The overall classification framework

C Decision tree from classification framework



D AHP Rating Scale

Rating	Definition
9	Row extremely more important
8	Row very strongly to extremely more important
7	Row very strongly more important
6	Row strongly to very strongly more important
5	Row strongly more important
4	Row moderately to strongly more important
3	Row moderately more important
2	Row equally important to moderately more important
1	Row and column equally important
1/2	Column equally important to moderately more important
1/3	Column moderately more important
1/4	Column moderately to strongly more important
1/5	Column strongly more important
1/6	Column strongly to very strongly more important
1/7	Column very strongly more important
1/8	Column very strongly to extremely more important
1/9	Column extremely more important

Figure 28: AHP rating scale