



FACULTY OF SCIENCE AND TECHNOLOGY

BACHELOR'S THESIS

Study programme / specialization: Bachelor Maskiningeniør	The spring semester, 2023 Open
Author: Marcus Berge Snorre Leret Pettersen	
Supervisor at UiS: Chandima Ratnayake Mudiyansele	
Thesis title: Product development: Ergonomic support tool for hydraulic bolting	
Credits (ECTS): 20	
Keywords: Product development Support Tool	Pages: 79 + appendix: 51 Stavanger, 15. May 2023

1. PREFACE

The bachelor thesis represents the knowledge gained of attending a three-year university bachelor's degree in mechanical engineering. The group is happy to present its work and hope this thesis will both serve and inspire in the area of product development.

Knowledge gained from the course 3D-Modelling and Product Development MSK220 will be the backbone of this thesis. Other courses like Finite Element Method MSK250, Mechanical Design MSK210, Structural Mechanics BYG140 and Production and Manufacturing Processes MSK260 are also highly relevant.

This project is focused on product development of an ergonomic support tool tailored for upturned bolting with Hytorc hydraulic torque wrenches. There is a similar support tool in use by Siemens Gamesa, but it is not compatible with the Hytorc bolting systems. Snorre, who has been working with bolt inspection in wind turbines for Hytorc parallel to the studies, saw this as a great opportunity to do a thesis where an actual product for an actual problem is created. By joining forces with Marcus, who has long experience within the field of CNC machining at Aarbakke, the group has the necessary skills and knowledge to go through a product development process from start to finish. The goal for the support tool is to enable the operators to perform their work more safely and efficiently.

The projects group consists of Snorre Leret Pettersen and Marcus Berge. Proper teamwork and determination have enabled the group to reach the initial goals of the project.

The group would like to express their appreciation to the people who have assisted in this project. First and foremost, Professor Chandima Ratnayake Mudiyansele who has been the advisor of the thesis. Hytorc, represented by Daniel Tønning who has provided much needed insight from the intended users. Finally, the personnel at UIS workshop and Aarbakke AS for their help with providing machinery and assistance regarding the projects manufacturing process.

2. SUMMARY

This thesis is about product development and manufacturing based on ideas gathered from personal experience from the industry. By performing bolt inspection at the top flange in a wind turbine, where the operator manually holds the heavy torque wrench, an idea was formed to find a solution where the job could be done safer, faster and more comfortably. Both group members were interested in coming up with a project where they could be working with the theoretical aspects of development, design and calculations in combination with the physical manufacturing of a final product.

The scientific approach of this thesis is based on Action based research, Case study research and Product Development Process (PDP), where the group have mainly depended on the principals and methods of the product development process. Through brain storming, discussions with other bolting operators from the work in the wind turbines and more formal interviews with the most experienced field engineer in Hytorc Norge, data was gathered to start the process of finding the key attributes of the support tool. After having generated and discarded different concepts, a final combination of attachment bracket and lift mechanism concepts were chosen.

The design was based on using existing standard parts, such as the steel pipes used for the different tube sections of the body and piston, and the spring used to drive the piston. The first part that was chosen was the spring driving the piston, and from there the group could start choosing the other components. If the tool were to be designed without taking the dimensions of the standard components into account from the start, it would likely turn out very difficult or even impossible to manufacture. It would be a hard realization to find out that there are no springs available with a sufficient spring constant in the needed diameter and length after all other dimensions were set. Taking this approach has made a design that is highly over-dimensioned for buckling and plastic deformation, but it is a design that can be made with existing parts available on the market.

Through the project the group has been working a lot with Autodesk Inventor. In the beginning for making the first drafts for the concepts, to in the end doing the full assemblies and final revisions of the drawings. Mechanical strength calculations have been made by a combination of “hand calculations” in MathCad Prime and Ansys Mechanical for buckling analysis and other calculations.

For the manufacturing, a lot of different tools and techniques have been used. Additive layer manufacturing has been used for prototypes and final parts. For the remaining steel parts, everything has been manufactured by CNC machines. By making use of use of Marcus’ experience with machining, the CNC programs used has been created by the group itself.

The manufacturing and the testing and refinement processes each had their unforeseen challenges. The group has done a lot of modifications and found creative solutions to the different challenges that

arose. Dealing with these real-life challenges is a part of what makes this kind of thesis special. There are a lot more complications to doing actual manufacturing than to making a model to do analysis on in Inventor 3D-space.

After a lot of work and modifications a final product was formed. The project has been very interesting and educational. New tools and techniques have been learned, and the process has given a lot of perspective regarding all the factors that needs to be taken to account to create a well-functioning product. Both the group and Hytorc were pleased with the final product.

A demonstration of the work scenario and the finished tool can be seen on Vimeo:

<https://vimeo.com/826654158>

An overview of all the related videos is in the Appendix table A-1.

3. TABLE OF CONTENTS

- 1. PREFACE i
- 2. SUMMARY ii
- 3. TABLE OF CONTENTS iv
- 4. INTRODUCTION 1
 - 4.1 Project background 1
 - 4.2 About Hytorc 1
 - 4.3 Mission statement 2
 - 4.4 Constraints 2
 - 4.5 About the report 2
 - 4.6 Timeline and schedule of activities 2
- 5. THEORY 5
 - 5.1 Methodology 5
 - 5.1.1 Action Based Research 5
 - 5.1.2 Product development 5
 - 5.1.3 Case study research 8
 - 5.2 Manufacturing 9
 - 5.2.1 Subtractive manufacturing 9
 - 5.2.2 Additive manufacturing 10
 - 5.2.3 Lean manufacturing 11
 - 5.2.4 SMED, Single-Minute Exchange of Die 12
 - 5.3 Ergonomics 14
 - 5.3.1 Ergonomic considerations for this project 15
- 6. DEVELOPING THE SUPPORT TOOL 16
 - 6.1 Planning 16
 - 6.1.1 Identify opportunities 16
 - 6.1.2 Allocating resources and timing 18
 - 6.1.3 Complete planning 18
 - 6.1.4 Self-Reflection of the Planning process 19
 - 6.2 Concept development 20
 - 6.2.1 Customer needs 21
 - 6.2.2 Specifications and features 24
 - 6.2.3 Generate concepts 25
 - 6.2.4 Selection of concept 29
 - 6.2.5 Final concept specifications and features 35
 - 6.3 Design and dimensions 39

6.3.1	Piston and main body tubes.....	39
6.3.2	Attachment bracket.....	40
6.4	Calculations.....	42
6.4.1	Initial spring calculations	42
6.4.2	Buckling	43
6.4.3	C-bracket	45
6.4.4	Clevis pins	47
6.4.5	Attachment bolt	47
6.4.6	Piston lock	48
6.5	Manufacturing the Support Tool	49
6.5.1	The Manufacturing Plan.....	50
6.5.2	Manufacturing each individual part.....	51
6.5.3	Health, Safety and Environment.....	58
6.6	Testing, refinement and results.....	59
6.6.1	Weight reduction	59
6.6.2	Liner	62
6.6.3	Pipes - dimensions.....	64
6.6.4	Pipes – seam weld	64
6.6.5	Piston lock	64
6.6.6	Attachment bolt and Handle.....	65
6.6.7	Attachment body	65
6.6.8	Allowing angular movement for the wrench.....	66
6.6.9	D2 threaded cap conn.	67
6.6.10	Results	67
7.	ECONOMICS	70
8.	DISCUSSION	73
9.	CONCLUSION	76
10.	BIBLIOGRAPHY	77
11.	APPENDIX	Feil! Bokmerke er ikke definert.

4. INTRODUCTION

4.1 Project background

The idea for this bachelor thesis came from Snorre. He works in Hytorc, where he does bolt inspection on the load bearing flanges in wind turbines, using powerful hydraulic torque wrenches. On the top tower flange in the wind turbines, there is a flange that is only accessible from below. This means that in order to disassemble the bolts in order to do the inspection, one must keep the heavy tool lifted in work position for the whole duration of the operation. This has two big disadvantages. The obvious one is that it is taxing for the body to keep a heavy tool (approximately 12kg with the relevant accessories for this job) suspended in an awkward position for a period. There are a lot of bolts on this flange, and it is very straining for both arms and back. The second reason is that the operators should never hold the torque wrench when pressurized. These tools operate on very high pressures and can exert extreme forces (maximum capacity for ICE 5 is 689bar/7268Nm). If something goes wrong during operation, the results can at worst be fatal.

To deal with this problem, an ergonomic solution where you can remove yourself from the tool during operation needs to be designed. There is a tool in use by Siemens Gamesa that is made to deal with this issue, but it is not compatible with Hytorc tools. On background of this Snorre suggested doing a product development thesis where the end goal would be to have a finalized tool that is dimensioned and designed to fit Hytorc's hydraulic torque wrenches.

The idea was formed in the fall of 2022 and presented to Professor Ratnayake who was fascinated and motivated the group to keep pursuing this as a bachelor thesis. The idea was then presented to Hytorc, they were intrigued and wanted to aid through the project.

4.2 About Hytorc

Hytorc is an American company operating worldwide that specializes in industrial bolting solutions (Hytorc. n.d., para. 1). With over 50 years of experience combined with their knowhow the company is industry leading. They are present in different industries, providing bolting solutions for wind turbines, oil and gas industry, power plants, everywhere one finds a bolting application, Hytorc can provide its assistance. Hytorc design, develop, and distribute their torque wrenches, of both hydraulic and pneumatic function, and associated accessories. Hytorc Norge AS is the division operating to serve the Norwegian and the rest of the Scandinavian market (Djuve, E. n.d., para. 1). They are located at Forus, Stavanger. Hytorc Norge provides services like rental, calibration, maintenance, training, and related engineering solutions.

4.3 Mission statement

The mission for this thesis is to design and develop a physical prototype of an ergonomic support device for upturned bolting with the hydraulic torque wrenches from Hytorc.

4.4 Constraints

The support device is going to be manufactured, this will affect how deep and wide the group can explore this project. The chosen designs will be of a high margin of safety and decisions regarding standard components will be made quickly in order to stay within the time limit. There will be a time limit of how much physical refinement of the support device the group can pursue, some work will be done, and some will be reported in writing.

4.5 About the report

The report is structured like a scientific report. The Table of Contents will show in depth the chapters and subchapters of the report. The main chapters are Summary, Introduction, Theory, Developing the Support Tool and Conclusion. The Summary is a short version of the whole report, covering the basics and essence of this project. This chapter will make understanding the whole report easier.

In the appendix one will find videos, drawings, engineering calculations, CNC programs, manufacturing plans and part list. The function of the appendix is to contain relevant information about the project that would not fit properly in the report because of its size and format. This information will be referred to when appropriate in the report. Due to the groups extensive experience within the field of manufacturing, the research and theory has been more directed towards the Product development process and relevant methodology than theory regarding physical manufacturing.

4.6 Timeline and schedule of activities.

For a project to be successful, it is necessary to have a plan. Project goals must be set for the group to reach. Setting goals in the form of milestones of activities and timelines is efficient and will guide a project through its different phases. The project group can with ease identify throughout the project which activities that must be done at what time. A timeline and milestones will also be relevant information to display for advisors and associates to the project. In this project the group has decided that the milestones set will be displayed as a table of activities. The table will contain information as to what, when and for how long. As for the timeline, this will be displayed in the form of a Gantt chart. A Gantt chart is a graphical representation of a project schedule (Grant, 2022, para. 1), in this case a chart-representation of the schedule of activities. It's a bar chart, each bar represents an activity of the

project, the bars are stacked in the y-axis, and drawn out in the x-axis to represent the amount of time the activity will take (Grant, 2022, para. 2). From the beginning of the project the activities/milestones (table 1) and following timeline are estimated paths. In such a project, activities may take longer than projected, this is when the schedule of activities and Gantt chart (figure 1) will easier get the project back on track (Grant, 2022, para. 3). A Gantt chart of actual-time-spent will be updated at the end of the project, where one can compare the estimates vs. real time spent.

Table 1, Schedule of activities, milestones

Activity:	Duration: (Week 3 – 16)	Week number:
Planning	2	3 - 4
Research	2,5	5 -7
Mechanical design	3	7 - 9
Production	2	9 - 10
Refinement	0,5	11
Testing	0,5	11
Conclusion	0,5	12
Report	3	13 - 16
	Total: 14 weeks	

It is estimated 14 weeks in total work of the thesis. From week 3 to week 16.

The groups deadline is set 3 weeks before the official deadline (15/5-23) which provides a buffer.

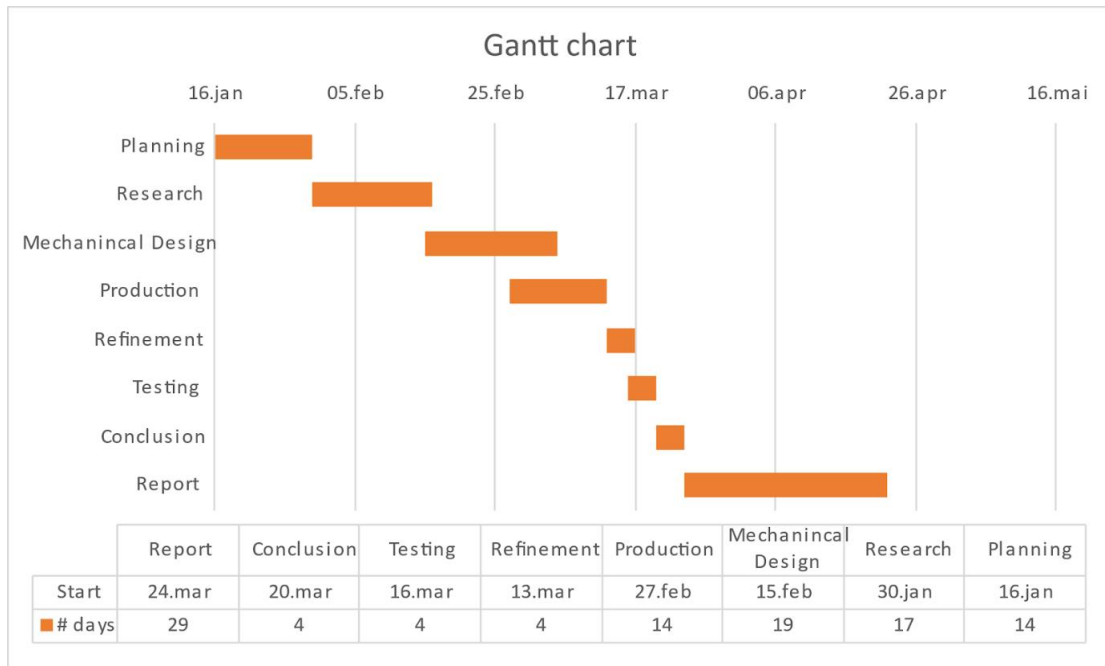

Figure 1, Gantt chart - estimated timeline

5. THEORY

5.1 Methodology

5.1.1 Action Based Research

Action based research is in a way “learning by doing” method. One identifies the problem, works out a solution, applies the solution and sees if it worked (O’Brien, 1998, p. 2). If it doesn't work, one tries again. This is a simplification of action-based research. The researchers are typically the individuals who are working in the situation where the problem occurs. Even though it may seem like an everyday problem solution method, and therefore seem too trivial to be distinguished, it is considered a scientific research method. The researcher uses a systematic approach backed up by theoretical knowledge to solve the problem (O’Brien, 1998, p. 2). The key feature of the method is that the ones who stumble upon the problem (who works in the related work scenario), are the ones who resolve it. They are the ones with the knowledge of the situation, and therefore may have the best chance to find the right solution. Action based research is a widely used technique and is often applied in educational, social and engineering studies.

5.1.2 Product development

The simple definition of a product is something that is manufactured and then sold to a customer. When an enterprise wants to create a product, they should perform Product Development. This is a method containing several steps of activities where the goal is to develop the best product for a market (Eppinger & Ulrich, 2012, p.2). In a product development project, a market opportunity is thoroughly explored, set in motion in the form of production, and finally sold and distributed to the customer.

A product development process typically contains several fields of expertise such as engineering, finance, marketing and manufacturing (Eppinger & Ulrich, 2012, p.3). Teamwork is essential to be able to cooperate throughout the product development process, all individuals with their expertise need to work efficiently together. All these individuals are therefore connected in a Project Team and a Team leader is typically appointed. The project team can be divided into smaller sub-teams depending on the size of the project.

There are several aspects about product development which makes it challenging, some of them are (Eppinger & Ulrich, 2012, p.6):

- Time: This is a time-consuming process, and the team must make decisions based on the constant pressure of time.
- Money: Large investments are needed in product development; one needs to be able to use the money now and get paid later.
- Trade-offs: There will be times, most likely several times, when the project group must take tradeoff decisions. Get one good solution at the cost of foregoing another one.
- Diversity of the team: There are many people involved with different skill sets, and their opinions on what is for the greater good for the project, may conflict with other team members' opinions. Good cooperation between departments is critical and will save time.

In the book from Eppinger & Ulrich (2012, pp.12-16) they describe product development as a stepwise process of six phases:

1. Planning: This activity is often called phase zero. The business opportunity is discovered. Several opportunities are usually discovered, then all these are evaluated, and the single best opportunity is pursued. The Real-Win-Worth-it method (RWW) will help the group to select the most promising opportunity by raising elementary questions concerning feasibility, financially and worthiness aspects of the opportunity (Eppinger & Ulrich, 2012, pp.47-48). The planning phase will set the boundaries, assumptions and goals for the product to be developed, leading to the creation of the projects mission statement (Eppinger & Ulrich, 2012, p.12).
2. Concept development: In this phase the needs of the market are determined, interviewing customers are a common approach of collecting such needs (Eppinger & Ulrich, 2012, p.76). From the needs many different concepts are generated. The best concept is chosen by methods of ranking, the final concept may be derived from several of the other concepts by choosing desired features and combining them together (Eppinger & Ulrich, 2012, p.17). A common concept screening method is the Pugh concept selection, concepts are compared and ranked to narrow the number of promising concepts (Eppinger & Ulrich, 2012, p.150). The concept will then describe the form, function, features, economic justification and how this product will compare to exciting products on the market (Eppinger & Ulrich, 2012, p.17).
3. System - Level design: This is the phase when designing and engineering really begins, so the physical design of the product starts to appear (Eppinger & Ulrich, 2012, p.15). Decisions on materials to use, important features and subsystems of the product will be decided. Then, planning manufacturing and assembly is the last activity in this phase.

4. Detail design: This phase is an extended in-depth version of phase 3. All details, every feature and function, all subsystems are determined and approved (Eppinger & Ulrich, 2012, p.15). Every underlying document like CAD files, drawings and such are finished. This results in the completion of the final design before testing and refinement. The whole production process will then be approved and ready for producing the first prototypes.
5. Testing and refinement: A prototype is built and tested (Eppinger & Ulrich, 2012, p.15). There may be several versions of prototypes. Some may not include all the exact parts and may be manufactured in a different material. Thoroughly testing is performed on later versions of the product with typical tests like durability and dynamic tests for long lasting performance. From the testing the team will know if the product works as intended and for it to meet the needs identified early in the development process. If not, refinements are performed, then tested again to perfect the product before full scale production.
6. Production ramp-up: This is the phase when the first actual product goes into production and later supplied to the first customers (Eppinger & Ulrich, 2012, p.16). Feedback from these customers will get reviewed and relevant changes to the product are done. In this phase the production will gradually become perfected and efficient to eventually get the full-scale production going and the product will be officially launched to the market.

In figure 2 the 6-phase process is illustrated.

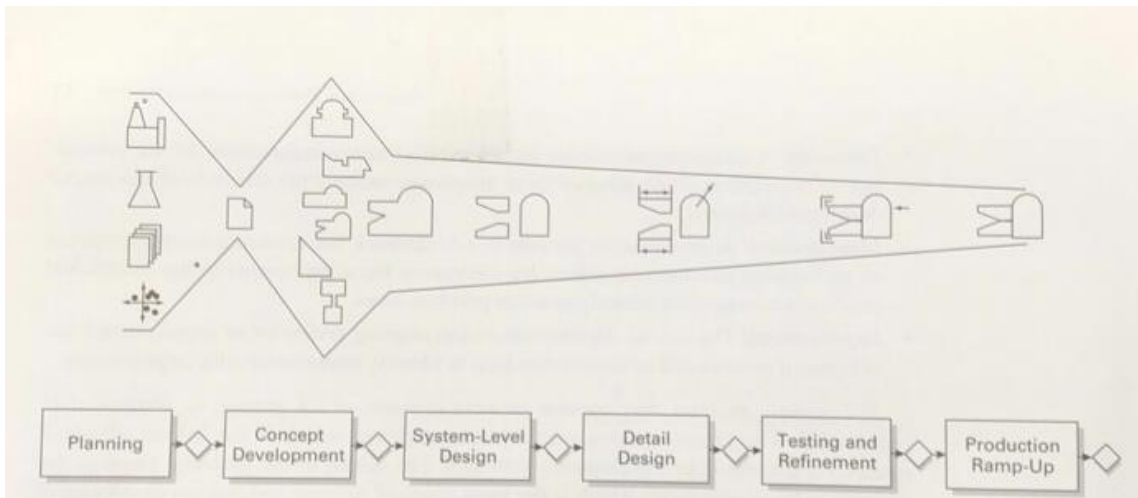

Figure 2, The generic product development process (Eppinger & Ulrich, 2012, p.14)

5.1.3 Case study research

Case study research is for many understood to be a type of qualitative research, but by having characteristics that proceeds qualitative research, case study research is also considered to be an independent type of research method (Yin, 2018, p.18). The definition of case study as a research method:

“A case study is an empirical method that investigates a contemporary phenomenon (the case) in depth and within its real-world context, especially when the boundaries between phenomenon and context may not be clearly evident.” (Yin, 2018, p.15)

The goal of case study research is to get a deep understanding of the subject studied, in other words, understanding the case (Yin, 2018, p.15). The method allows one to focus in-depth on a case, what it is, how it works, and how it interacts with its real-world environment. It is important to find rival explanations and examine their plausibility, to get a precise understanding of the case.

When to use case study research?

When to use what method of research, depends on the questions that will arise in the case to be researched, questions like: “who”, “what”, “where”, “how” and “why” (Yin, 2018, pp. 9-13). The form of the questions raised, can provide an important clue regarding the appropriate research method to apply. Case study research is relevant to use when the questions “how” and “why” are raised.

The case study research approach?

The “how” and “why” questions must be accurate for the topic. This means that one should study information about this topic like previous research, tests, articles etc. to be able to raise these “how” and “why” questions again, but in a sharper and more direct fashion relating to the case (Yin, 2018, p.13). One must discuss both negative and positive effects of starting with the stated research questions. The method(s) used to gather data must be justified, one must discuss the alternative methods and why these were not chosen.

The 6-step process

Case study research can be considered a 6-step process as following (Yin, 2018, p.2):

- Plan
- Design
- Prepare
- Collect
- Analyze
- Share

The process is self-improving. Except for the first stage (Plan) and last (Share), the stages are revisited for improvement as the research proceeds.

5.2 Manufacturing

The word manufacturing is combined of the two Latin words for “hand” and “make”, which results in the meaning “made by hand” (Groover, 2021, p.2). “Made by hand” describes well that it was manual processes conducted to make the tools, weapons, and other equipment way back in our history. This is the foundation of the modern manufacturing of today.

Today’s modern manufacturing is understood both in a technological and in an economical fashion. The technological aspect defines manufacturing as the alteration of a starting material in a physical and/or chemical manner to change the material’s geometry/appearance/properties to make a desired product (Groover, 2021, p.4). For this transformation of a material to happen it involves processes carried out in a combination of labor, machinery, tools and power. The economical aspect defines manufacturing as a set of activities to a starting material which adds value (Groover, 2021, p.4). Doing the alteration will eventually add a value. For example, transforming oil to gasoline adds value to the starting material.

There are many different manufacturing processes, these can be divided into main groups and subgroups (Groover, 2021, pp.10-13). First main group is Processing Operations, this is the group that contains the processes that transform a starting material to another desired form/appearance/property. Shaping (drilling, turning, milling, casting), surface (coating) and property-enhancing (heat treatment) are the processes in this group. The second main group are Assembly Operations (Groover, 2021, p. 15), this group contains the manufacturing methods that join two or more separate parts into a new entity. There are permanent joining processes like welding and bonding, semi-permanent processes like expansion fitting and press fitting, and mechanical assembly methods that temporary join parts together and can easily be disassembled like bolts and screws.

5.2.1 Subtractive manufacturing

Subtractive manufacturing is a collective term of several manufacturing methods. Material is subtracted(removed) from a starting material to get the desired geometry. Conventional machining is the main form of subtractive manufacturing, which the essence is that a sharp tool cuts off material. The cutting action is a shear deformation of material caused by the sharp cutting tool which creates a chip that is cut off and new surface is exposed, then a new geometry to the starting material is achieved (Groover, 2021, p. 447). The machining methods is performed by specific machines, both manually operated (wheels and levers) or computer operated (CNC, computer numerical control).

The most common machining methods are:

- Milling
- Turning
- Drilling
- EDM (electronic discharge machining)

5.2.2 Additive manufacturing

Additive manufacturing (AM) is a collective term of methods to fabricate a component of a geometry that is constructed by a computer aided design (CAD) system. The manufacturing process creates the designed component by adding material in a layer-by-layer sequence until the whole geometry is constructed (Groover, 2021, p. 755). In contrast to subtractive manufacturing, which remove material, additive manufacturing adds material, a complete opposite process. AM is a quite new technology, and the potential is significant. The advantages are manufacturing in a short amount of time and less waste in the process compared to subtractive manufacturing (Groover, 2021, p. 758). The field of AM is evolving fast and new technologies are quickly utilized. AM is divided into seven categories:

- Vat polymerization
- Powder bed fusion
- Binder jetting
- Material jetting
- Material extrusion
- Direct energy deposition
- Sheet lamination

Material extrusion – Fused-deposition modelling (FDM)

This is the AM method typically referred to as 3D-printing. Fused-deposition modelling is an AM, or more specifically ALM (additive layer manufacturing) technology where a filament, typically of thermoplastic polymer, is extruded through a heated jet to produce a part, layer by layer (Groover, 2021, p. 763). The work-head, which holds the jet, operates in the horizontal plane. By the completion of each layer, either the work-head or the bed is moved equal to one layer height along the z-axis. The extrusion is done by heating the material to a temperature right above its melting point and feeding it through the jet. The extruded material is solidified and cold-welded to the prior layer in approximately 0,1 seconds (Groover, 2021, p. 763).

AM with Markforged Metal X

In later years there has been a lot of development in the field of AM. As it is such a powerful tool for small scale production and prototyping, the need for AM technologies that can work with stronger materials has arisen. One of the metal printing technologies is the one used for the Markforged Metal X. The machine is capable of printing different metals and uses a filament made up of small metal balls bonded with wax. The method is a form of FDM which they call Bound Powder Extrusion. Currently, the available materials are 17-4PH stainless steel, copper, H13 tool steel, Inconel 625, A2 and D2 steel.

The printer extrudes a component that is approximately 25% larger than the final part. After printing, there is a lot of binder material in the part, and the part is also very weak because the metal has not yet been bonded. The printed part is placed in a chemical bath which removes the wax in the part and should reduce the weight by 4%. To ensure that the wax has been sufficiently removed, the part can be weighed after washing.

After washing and drying the part, it is ready for sintering. In this part of the process, the part is placed in an extremely hot oven where the small metal balls are bonded together through pressure and heat without reaching the material's melting point. The printer can extrude layers with a thickness of 50-125 μ m after sintering. (Markforged Inc, n.d.)

5.2.3 Lean manufacturing

Lean manufacturing is manufacturing that has been optimized with the necessary applied work for eliminating wastes of the manufacturing (EconClips, 2020 2. December, 00:30). The effects of minimizing wastes are reduced costs, shortened delivery, increased quality and maximized value. These effects of waste reduction are the goals of Lean manufacturing. Lean manufacturing is derived from the Toyota Production Systems dated back to the 50s and 60s (EconClips, 2020 2. December, 04:00). Toyota were using techniques such as Jidoka and Just-in time. Jidoka, A method of quickly identifying and correcting problems that could lead to production defects. Just-in-time, improving and coordinating all production processes in such a way as to produce only what the next process requires.

The term “Lean” was first used by John Krafcik in the late 80s, and describes perfectly the idea to have leaner production, use less resources, engineering and labor etc. to manufacture the same amount (or even more) as regular mass production (EconClips, 2020 2. December, 01:20). Lean defines waste as: “Any action that consumes resources without adding value to the customer” (EconClips, 2020 2. December, 00:53).

The 8 wastes of Lean are defined as (Trout, J. n.d., para. 2):

- Defects
- Overproduction
- Waiting
- Non-utilized talent
- Transportation
- Inventory
- Motion
- Extra processing

The principles of lean manufacturing are to define value, determining value stream, create free flow of materials, implementing a pull system in the customer-supplier relationship and constant pursuit of perfection (EconClips, 2020 2. December, 02:10). Both physical and mental transformations in the workplace will be applied in lean manufacturing. To be able to minimize the wastes, Lean has a “toolbox” with several techniques. These tools are (EconClips, 2020 2. December, 02:41):

- 5S
- Value mapping
- Total productive maintenance
- SMED
- Error proofing
- Kaizen, continuous improvement

Lean was first intended for manufacturing, but now the Lean way of thinking is applied to other industries and environments such as, Lean organization and Lean enterprise, Lean health, Lean service, Lean logistics and more. Lean Management is the new term widely used when a company whatever industry is applying Lean in their business (EconClips, 2020 2. December, 01:57).

5.2.4 SMED, Single-Minute Exchange of Die.

In manufacturing there are lots of wastes, one crucial waste is waiting. An effective tool to comprehend this is SMED in Lean manufacturing. SMED stands for “Single-minute exchange of die” and is understood as: to limit change-over-time to less than 10 minutes, single digit minute time (Lean Production, n.d., para. 1). One can view this as simply to use less than 10 minutes to shift from producing part A to part B.

In this day and age, with consumers' expectations of variety and constant flow of new products, it is crucial that a company is agile. To stay in business, you need to make changes quickly, cheaply and efficiently. In the automotive industry this is very relevant. It is difficult to produce a car and there are many challenges like:

- Many different components
- Work operations
- Required vast knowledge base
- New features demanded
- New regulations
- Hard rivalry in the market

If an automotive company does not have the ability to take on all these factors (and more) in an efficient manner, they will not survive, that is why Lean manufacturing and SMED is important.

Using SMED, one will analyze everything that goes into making the product: tools, machines, material, parts etc. to investigating each little process and making it more efficient. When investigating you want to divide work into two segments (Lean Production, n.d., para.3):

- External set-up time, work that can be performed when process is running.
- Internal set-up time, work that cannot be performed while process is running.

The goal is to get as much work as possible segmented into the External set-up time.

Examples of SMED applied in manufacturing:

- Prepare tools for product B when machine is running product A.
- Minimize the distance between machines and tools.
- Strategic and practical plant layout.
- Materials and parts to be delivered by conveyor instead of workers leaving the workstation to manually collect materials and parts.

All these examples result in lower costs, higher versatility and minimized batch sizes.

5.3 Ergonomics

In the industry there are countless tasks and operations that have the potential to harm your body or cause strain over time. Ergonomics based engineering and product development can help reduce the stress put on a laborer's body by either establishing procedures to eliminate such operations, or developing tools that can relieve the laborers from unnecessary stress. As technology progresses and HSE requirements increase, there is a growing demand for ergonomic tools on the market.

There are 10 basic principles of ergonomics (MacLeod, 2006):

- Work in neutral postures
- Reduce excessive force
- Keep everything in easy reach
- Work at proper heights
- Reduce excessive motion
- Minimize fatigue and static load
- Minimize pressure points
- Provide clearance
- Move, exercise and stretch
- Maintain comfortable environment

Some examples of ergonomic features/challenges that are considered when designing industrial tools:

- Weight distribution: By locating and adjusting the position of the center of mass, one can make the tool more easily manageable. While a top-heavy tool might be unstable and straining to use, a version with lowered and centered mass center will prove less straining for the operator (Karwoski, 1999, p. 470-471).
- Handle design: Instead of a cylindrical bar, handles often come in more ergonomic designs for a more comfortable and steadier grip. Padding, contouring and non-slip materials will increase the grip and reduce hand fatigue (Karwoski, 1999, p. 852-854).
- Drill clutch: While the drill clutch is primarily designed to avoid over tightening of bolts and screws, it can also be used to avoid damage to the operator's wrist. If operated without the clutch, the drill will recoil when the bolt is bottomed, especially at high speed.
- Weight reduction: Looking at ways to reduce the overall weight of a tool can be a good approach to making the tool more ergonomic. Through stress analysis it can be determined whether you can reduce material or change to a more lightweight material.
- Vibration reduction: Excessive exposure to vibration can be very harmful to the body and may lead to hand-arm vibration syndrome (HAVS). HAVS is a serious disability and is typically

chronic(Bugge, 2021). Vibration is especially a problem in the construction industry, and a lot of the modern tools are integrated with vibration reducing technologies. Spring dampened handles, shock absorbing materials and other technologies are effective ways to reduce the strain on the operators.

- Lifting reduction: Lifting and carrying of heavy objects is very straining for the body in the long run. In the workplace it isn't always easy to lift with proper form, and bad posture and heavy weights is not an ideal combination. Tools that help lift and position the power tools are very useful to reduce the strain on operators. Different types of hoists and cranes are a necessity in the industry, and when designing heavy tools attachment possibilities should always be considered in the design.

5.3.1 Ergonomic considerations for this project

The whole basis for this project is to make a support tool that will reduce the amount of heavy lifting and positioning in awkward working positions. To make the tool as ergonomic as possible, it is important that the support tool is either attached at (or near) the center of mass in the horizontal plane, or otherwise weight compensated in some way. Attaching the support tool far from the COM will make it less stable and more straining to operate.

Accessibility for the positioning and adjustment features should also be considered in the design. The attachment bracket and height adjustment mechanisms should be placed and designed in a way that makes the tool easily operated in its working position.

6. DEVELOPING THE SUPPORT TOOL

In this chapter the actual development of the support tool is described. Developing the Support Tool was carried out by applying the methods and phases of the six-phase Product Development Process described in the book from Eppinger & Ulrich (2012, pp.12-16). Not every phase of developing the Support Tool is exact the same as in the standard PDP, the group has tailored this process and applied needed methods influenced by the standard PDP while integrating methods from Action based research and Case study research.

This project combined Case study research and Action based research to gain insight and address various aspects of the problem from the start. The Case study research principles were applied when the group investigated the “how” aspects of the problem, “how can it be resolved”, “how will such a tool operate”, “how will the developed tool facilitate customer needs”. In addition, the group discussed and dwelled on the “why” element of the problem, such as “why is there a need for the tool”, “why is the manual handling of the work scenario a hazard”. By implementing early-stage trials with the ease of rapid prototyping, the group could quickly discard or continue with an idea, this way of approach directly links to the principle of Action based research.

6.1 Planning

The planning of the whole project is the foundation for what to come. This phase was carried out in a 4-step process:

- Identify opportunities
- Allocating resources and timing
- Complete planning
- Self-Reflection of the Planning process

6.1.1 Identify opportunities.

Identifying the opportunity was the thing that started this whole project. Snorre, who works in Hytorc with bolt inspection in wind turbines, got the idea from experience out in the field. When working with upturned bolting, Snorre saw the need for supporting the hydraulic wrench instead of holding it manually. In this step of the planning phase, a charter is normally set for the group as a guideline to create several opportunities (Eppinger & Ulrich, 2012, p.2). The charter for this project is more specific because of the opportunity Snorre identified. The charter was set to be as following:

“Create a portable, simple construction, support tool for hydraulic torque wrenches and to fit specifically to the Hytorc wrenches.”

To make sure that the identified opportunity was any good and justify keeping exploring this opportunity, a Real-Win-Worth-It method was conducted. The RWW was constructed as a set of questions asking real-, feasible- and financial-related questions in table 2. These questions were answered either Yes or No. In total there were substantial more yes-answers than no-answers, therefore the group continued pursuing this opportunity.

Table 2, Real-Win-Worth

Real	Is there a need?	Yes
	Can and will the customer buy such a product?	Yes
	Is the timing right?	Yes
Feasible	Can we manufacture the product?	Yes
	Do we have necessary resources?	Yes
Financial	Low cost to manufacture?	Yes
Total		6 / 6 = Yes

6.1.2 Allocating resources and timing

The planning on what to do, when to do it and for how long is described in the section 4.6 (Timeline and schedule of activities), as milestones. Planning of each activity provides more information of what the group planned for every activity to contain. Table 3 shows the elements that make up the plan.

Table 3, Planning of each activity

<u>Planning:</u> Time schedule of activities. Identify opportunities. Goal of project/Thesis. Assumptions and constraints. Reflect on the results and the process.	<u>Research:</u> Interviews. Choose the best opportunity.	<u>Mechanical design:</u> Choosing Distinct design features. Calculations. Modelling.	<u>Manufacturing:</u> Machining, 3D printing, welding etc. Assembling.
<u>Refinement:</u> Fine-tune the product. Correct possible mistakes.	<u>Testing:</u> Test the product. Performance. Results.	<u>Conclusion:</u> Conclusion. Reflect on the results and the process.	<u>Report:</u> Writing the report. Hand in 15/5-23

6.1.3 Complete planning

At this step the group took a view over the outcome of the project so far. This was the step where the group was completing the planning phase and confirming to pursue this project. Assumptions and constraints regarding features of the support tool and manufacturing were established.

Assumptions and constraints about the Support tool:

- Will fit the Hytorc wrenches
- Will be portable
- Easy to use
- Will be manufactured with available machinery

Constraints of manufacturing

The group has done research about machinery available to utilize in the manufacturing of the product. This was a constraining factor in the development of the tool, regarding the capability of the machines. UiS was intended to be the main facility of production, and assistance from Aarbakke and Hytorc were considered to be backup alternatives.

Taking in consideration the assumptions, constraints, opportunity and preliminary design, the group concluded to pursue the idea: “support tool for hydraulic torque wrench”.

Early mission statement

For this thesis the goal is to design a support device for upturned bolting/upside down bolting with hydraulic bolt wrenches from the manufacturer Hytorc. Hytorc currently has no support device, and supporting the hydraulic wrench is done by hand. This causes a lot of strain and potential harm to the operators. The tools are heavy and working positions can be quite awkward. Especially when loosening large bolts with high torque there can occur “cracking”, a powerful jolt when the nut finally loosens, resulting shock impacting the operator's arm and shoulder.

Goal of the project

Develop and manufacture a prototype of the support tool that is fully functional and ready-to-work in its designated work scenario.

6.1.4 Self-Reflection of the Planning process.

This is the final step of the planning phase. The group reflected on the outcome and what was achieved from the planning phase. It was reflected in the manner of “self-interviewing”, the group believed that this form of reflecting can be useful to detect any weaknesses to apprehend (Eppinger & Ulrich, 2012, p.49). These were the questions and answers:

Is the opportunity the right one to pursue?

- Yes, the group can see the need for such a tool, and the planning so far show that this opportunity is worth pursuing.

Did the group encounter any big issues?

- No big issues or surprises were revealed.

Is the mission statement over constrained?

- At this point of time the group don't see the mission statement over constrained.

Will we need to alter the mission statement before proceeding the development process?

- The mission statement may well be altered in some point of time. The group is thinking about shortening and combining it with the "Goal of the project"-statement.

How was the use of time?

- There was a substantial amount of time spent on researching a planning phase, what to include and not. The group see this as well spent time as the planning is an important phase of the project.

How can the planning process be improved?

- The use of time, the group has now discussed what is relevant to such a project in this phase, and therefore in the future can make decisions regarding planning faster.

6.2 Concept development.

In this section of the chapter Developing the Support tool, the group laid out the developing of concepts which ultimately lead to the foundation of the design to the Support tool. The group started with identifying the customer needs through gathering data. The specifications and features of the product were then defined as desired specifications and features. From the information gathered so far, the group started to generate concepts for the product. The group focused on "Attachment bracket"- and "Lift mechanism" -concepts. After generating promising concepts, the group started the selections of concepts. By utilizing ranking matrices and Hytorc's preference, the final concepts were chosen. The final specifications and features were then derived from the chosen concepts.

6.2.1 Customer needs

The group gathered their data through interview with Hytorc, researching the existing products on the market and through personal working experience of the work scenario. The interviewing questions presented to Hytorc was of a broader fashion. The idea was that Hytorc was then able to reply to their needs without being forced to answer too specific questions. The interview can be seen in table 4.

Table 4, Interview, customer needs.

Question	Customer reply
Function?	-We need a support tool for the upturned hydraulic torquing. -Need adjustability of length.
Ergonomic?	-We prefer a light tool, within reasonable weight. -Want the support to be moved as less as possible because of many nuts to be torqued.
Power supply?	-There are electric and hydraulic power supply available on the jobsite but limited, we prefer this tool to be without the need of any power. -Could be operated by a drill.
Other features?	-We would like to have it foldable. -Easy to assemble -Easy to maintenance -Space constraints regarding the location of nuts close to the wall. -Slippery floor because of oil residue
Material?	-Initially, we have no specific desire as for what type of material this tool must consist of.

Research of existing products on the market.

Initially the group were of the understanding that this kind of support tool was already on the market but for rival companies of Hytorc. After researching the group couldn't find any more information about these kinds of tools. After conferring with Hytorc representatives it became clear that the only known tool was the one Siemens Gamesa had made themselves for bolting in wind turbines. These are not compatible with Hytorc tools. The group was not able to get hold of any photos or documentation of the tool used by Siemens.

There was no available information of such a support tool existing on the market. The group decided then to rely on the data collected from the interview and from personal working experience. Upon realizing that there was no tool on the marked, it reinforced the justification even more to create this product and fill the gap in the market.

Action research

The idea of this tool/project came from personal working experience. By using the observations and insight from related field experience, the group integrated Action based research as a tool to gather information related to:

- Space constraints
- Portability
- Duration of work
- Desired features of such a tool, from a worker's perspective

Ranking and understanding the data collected

In this section the group interpret the collected data. The interpreted data was displayed to the customer, Hytorc, who ranked the data for least to most important feature. This gave valuable information to the project as to which features from the data collected, to focus on further with the project.

Table 5 is the Interpreted need and rank of data. The Customer reply – column, represents the replies from the “Interview, customer needs – Hytorc.”. The Interpreted need – column, was how the group interpreted the relating customer reply. The Rank – column is the rank score Hytorc gave to each need. The meaning of ranks 1 – 3 was as following:

- 3 → most important
- 2 → important
- 1 → least important

Table 5, Interpreted need and rank

Need No.	Customer reply:	Interpreted need:	Rank:
1	We need a support tool for the upturned hydraulic torquing.	The tool's main priority is to replace manually holding the hydraulic torque wrench	3
2	Need adjustability of length.	The tool has adjustable length.	3
3	We prefer a light tool, within reasonable weight.	The tool is lightweight.	2
4	Able to stay stationary for several nuts to be torqued	The tool can support in angle positions.	2
5	Power supply available but limited, prefer tool to be without need of any power.	The tool is manually operated, no power needed.	2
6	Could be driven by a drill.	The tool can be power-driven with the help of a drill	1
7	We would like to have it foldable.	The tool can be disassembled for transportation.	3
8	Easy to assemble.	The tool is easy to assemble.	2
9	Easy to maintain.	The tool is easy to maintain.	1
10	We have no specific desire as for what type of material this tool must consist of.	The tool's material will consist of the most convenient material.	1
11	We want this tool to have a low overall cost	The tool is of low cost	3
12	Space constraints	The tool requires less space to operate.	3
13	Greasy floor, need a non-slip foot.	The tool has a foot that is of non-slip material	1
	Personal working experience:		
14	Space and weight constraints.	The foot of the tool is of small size.	3
15	Adjustable height.	The tool has adjustable length.	3
16	Do need the approximate total height of the tool to be about 1,6 meters.	Total height of tool 1,6 meters.	2

6.2.2 Specifications and features

Desired specifications and features

At this point of the project the collected and interpreted data could form the desired specifications of the tool. These specifications were selected before knowing all constraints for achieving the project. From the processed data, the group could give each feature a metric and a value. Ideally, to each need there would be one metric and one unit, unfortunately this was not always the case, and several metrics and values would address one need. An example of a metric can be: “total mass”, and corresponding value: “kg”. The list of desired metrics is illustrated in table 6.

Table 6, List of desired specification metrics

Metric No.	Need No.	Metric	Unit
1	1	Load capacity	N
2	3, 14	Total mass	kg
3	2, 12, 15	Longitudinal adjustability	mm
4	4	Manual force applied to operate	N
5	5	Work output drill	W
6	5	Drill voltage	V
7	5	Drill capacity	Ah
8	7, 8	Foldable ability	Subjective
9	7, 8, 9	Number of parts	pcs
10	10	Yield strength	MPa
11	12, 14	Width	mm
12	16	Height	mm
13	11	Cost per unit produced	NOK

6.2.3 Generate concepts

The finished tool will have two main mechanisms. It needs a mechanism that securely attaches the support tool to the ICE 5 (the wrench that is typically used in the relevant work scenario), and it needs a mechanism that will lift the ICE 5 into working position. To find the optimal solution for each problem, there has been generated different concepts for each specific task. The different attachment bracket concepts are illustrated in figure 3-5.

Attachment bracket concepts

Concept 1

- Screw-on bracket with machined spheric profiles
- Design is based on Hytorc's own handle design
- The spheric profiles enters the spheric grooves in the wrench, and will supply torsional support as well as support in the horizontal plane

Concept 2

- Screw-on bracket with steel ball inserts
- This design is based on the same idea as concept 1, just with a different approach for the manufacturing
- More accurate spheric profiles than concept 1, but more complex machining

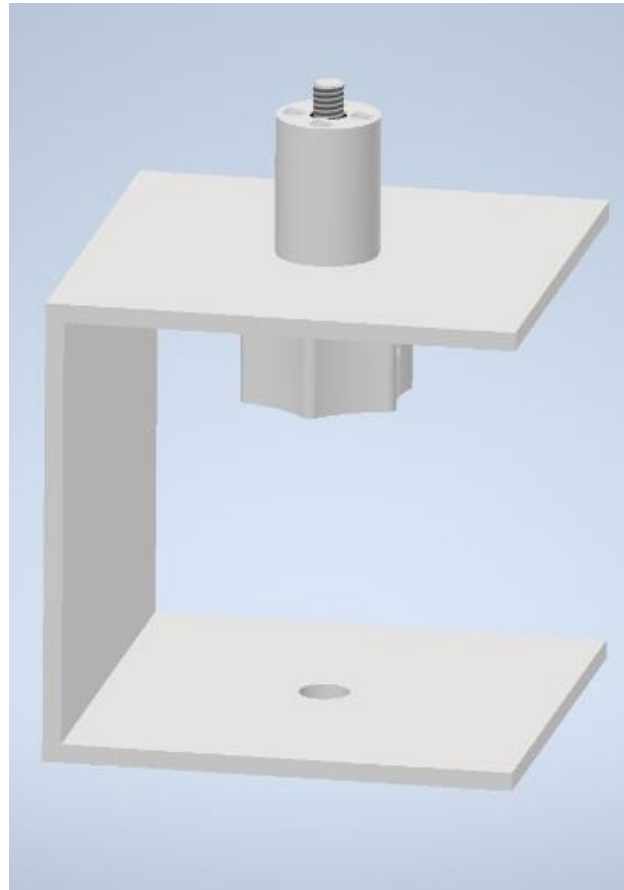

Figure 3, Attachment concept 1&2

Concept 3

- Clamps
- The clamp design is meant to clamp around the cylindrical area of the ICE 5
- Held by frictional force between clamp and tool

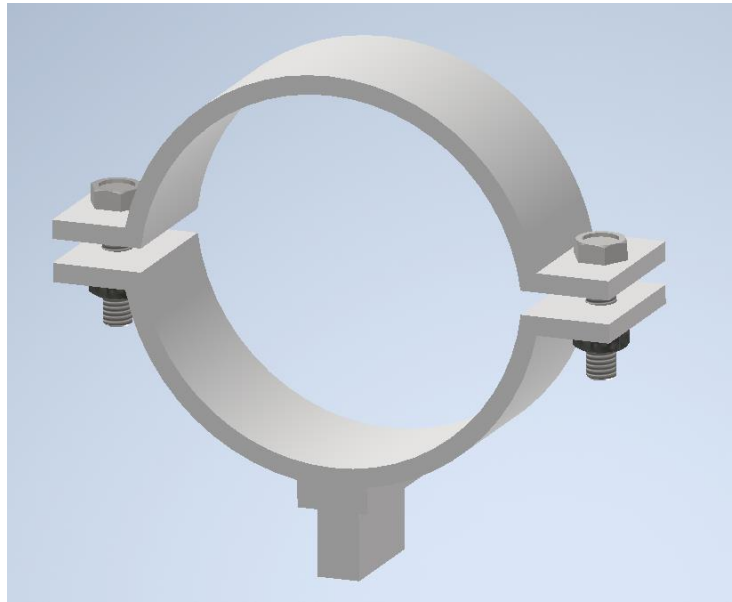

Figure 4, Attachment concept 3

Concept 4

- Clamps with attachable plate
- Combines the clamp and screw-on concepts. To prevent the ICE 5 from turning, it is locked in place with a screw through the plate.
- As the tool is rotated 180° when changing from tighten to loosen, there is one hole for attachment bolt per configuration.

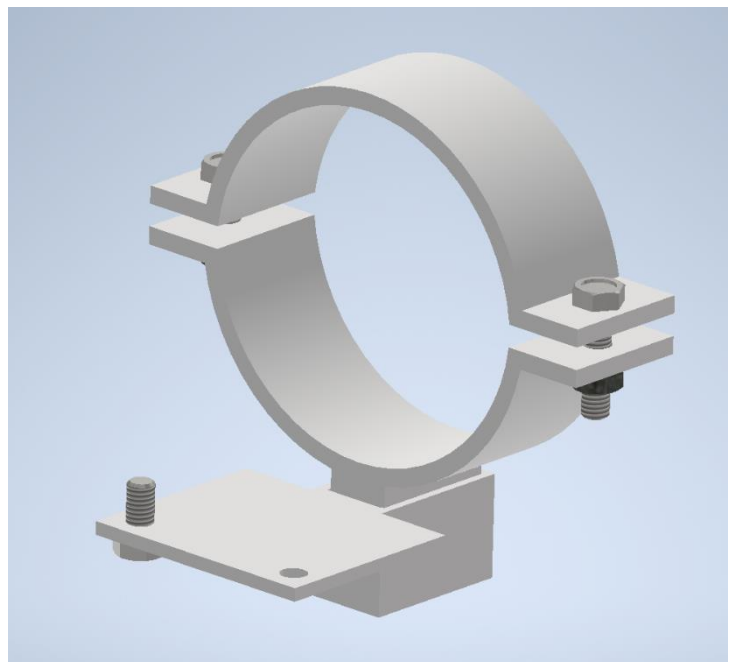

Figure 5, Attachment concept 4

Lift mechanism concepts

The illustrations the lift mechanism concepts are illustrated in figure 6-8.

Animation of the piston for concept 1 & 2 can be seen on Vimeo:

<https://vimeo.com/824318029>

Concept 1

- Coil spring piston
- This design concept will push the ICE 5 up into working position with the spring force generated by compressing the piston
- Simple but efficient concept

Concept 2

- Preloaded coil spring piston
- Same as concept 1, but at fully extended position the spring is precompressed enough to carry the full weight of the ICE 5 without displacing.
- Shorter piston member than Concept 1 due spring to precompression



Figure 6, Lift mechanism concept 1 & 2

Concept 3

- Tripod foot with rack and pinion jack
- Stable design where the ICE 5 is lifted by operating the jack
- Can be manually handled or driven by Drill
- Requires more floor space due to the tripod

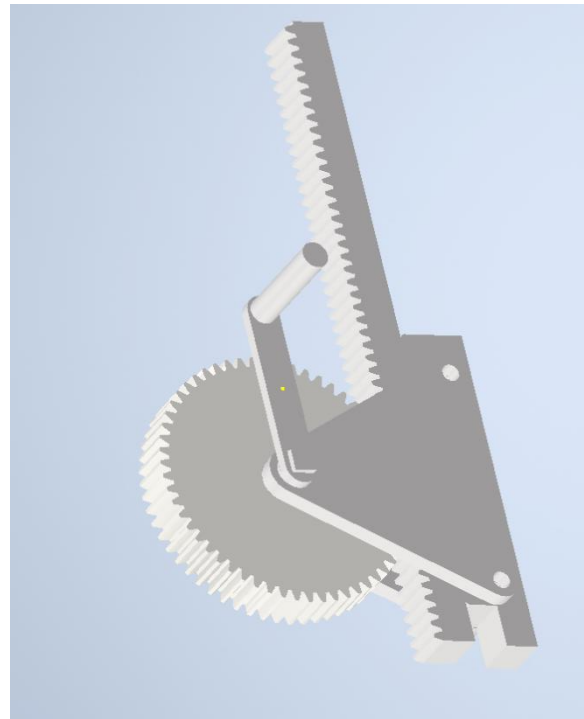

Figure 7, Lift mechanism concept 3

Concept 4

- Tripod foot with floor prop design
- Lifting mechanism based on a floor prop height adjustment mechanism
- The member leading up to the attachment bracket is a long stud that is fastened by a nut in the lower end

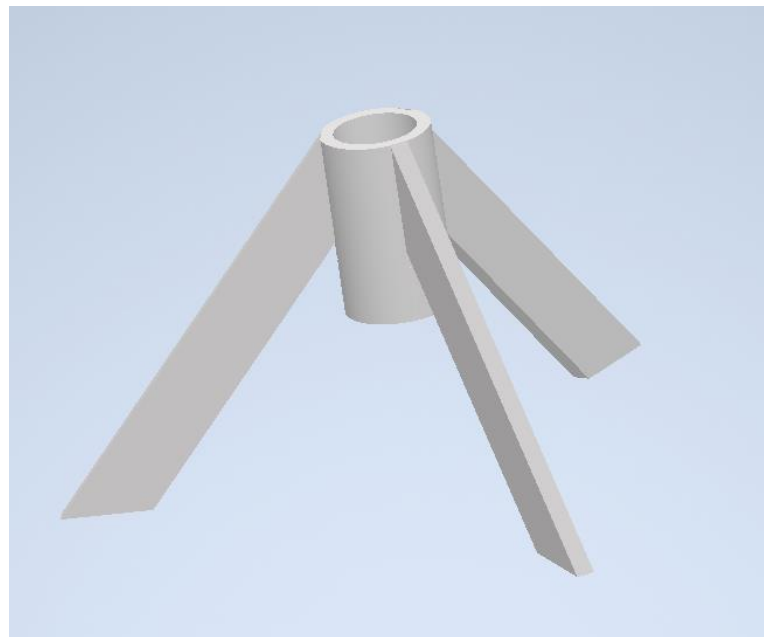

Figure 8, Tripod for Lift mechanism concept 3 & 4

6.2.4 Selection of concept

After exploring the different concept options, a decision has to be made. There are many different approaches on how to choose the final concept. some examples are:

- Product champion:
An influential member of the team selects the concept based on their personal preference
- Decision matrices:
The concepts are rated in accordance to specific selection criteria
- External decision:
The customer is presented with the different concepts and will decide which to pursue
- Prototype and test:
Create prototypes of the different concepts and conduct tests, the choice is based on the test data

For this project it was decided to use a combination of multiple methods like screening matrices, prototype and test and external decision. Since this is a product designed for Hytorc, it was logical that they get the final say in which concept to choose. For Hytorc to make the right decision, it must be based on solid data. To achieve this, the different concepts were ranked in screening matrices as well as doing prototyping and testing on the most promising concepts. This provides Hytorc with a solid foundation to base a decision on.

Attachment bracket concepts

Pugh concept selection

The first step in the concept selection process for this project was to establish the Pugh concept selection matrices. In order to get as concrete results as possible, it is critical to set the correct selection criteria. Through analysis of the data gathered from the interview and internal discussion a set of selection criteria were generated for each of the two mechanisms. Table 7 shows the concept selection matrix for the attachment bracket.

Table 7, Concept selection matrix – Attachment bracket

Selection criteria	Attachment bracket concepts			
	Machined spheric profiles	Ball inserts (Reference)	Clamps	Clamps w/plate
Ease of use	0	0	0	-
Ease of handling	0	0	0	0
Ease of manufacture	+	0	+	0
Performance	0	0	-	0
Stability	0	0	-	0
Robustness	0	0	+	+
Servicability	0	0	0	0
Cost	+	0	+	0
Sum +'s	2	0	3	1
Sum 0's	6	8	3	6
Sum -'s	0	0	2	1
Net Score	2	0	1	0
Rank	1	3	2	3

From the attachment bracket concepts there aren't any concepts that seem to be especially compatible or advantageous to combine, and thus the group rather put their focus on choosing one concept per category rather than finding a combined solution. From the concept scoring Concept 1 comes out as the top ranked solution. It is very similar to Hytorc's own handle design but is manufactured in a different way. Hytorc's original handle design is die cast with steel ball inserts that are pressed in, but because of the low quantity that's being manufactured, die casting is not an option.

Concept 1 is primarily preferred over Concept 2 due to ease of manufacture and thus the price, but it is not determined that the end product will be satisfactory due to the spheric profiles having to be milled, and resultantly not as round as the steel ball inserts.

Rapid prototyping

To get some more perspective regarding the results from the concept selection matrix, it was decided to do some additional testing. All bracket design concepts were designed with geometry easily compatible with additive layer manufacturing, and getting a physical representation of the concepts would make it easier to analyze what is the optimal solution. This strategy was crucial for the project, it saved time and quickly gave promising results, which emphasizes the importance of the principals of Action based research in this project.

For the rapid prototyping an Original Prusa i3 MK3S was used at the 3D printing lab at the university. All parts were printed in the material RS PRO Matte PLA 1,75mm with standard print settings for Generic PLA. The chosen setting was 0,15mm layer thickness QUALITY, which has a lower print speed to achieve a better result. Infill set to 50% to get rigid parts. The parts for concept 1 can be seen in the slicing software in figure 9 and the finished results in figure 10. The different prototypes mounted on the torque wrench can be seen in figure 11-13.

The primary test criteria for the prototypes will be ease of use and performance.

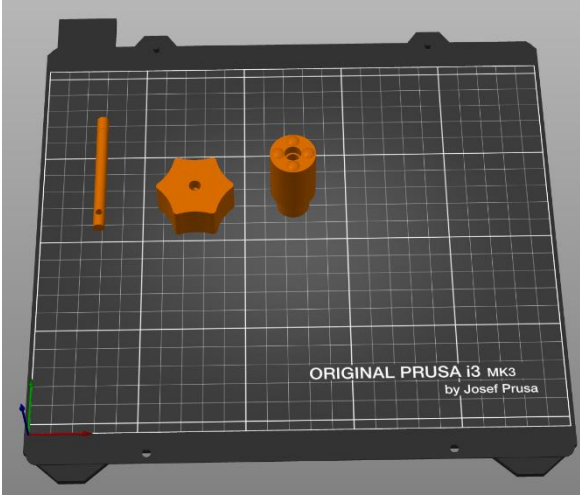

Figure 9, Sliced parts

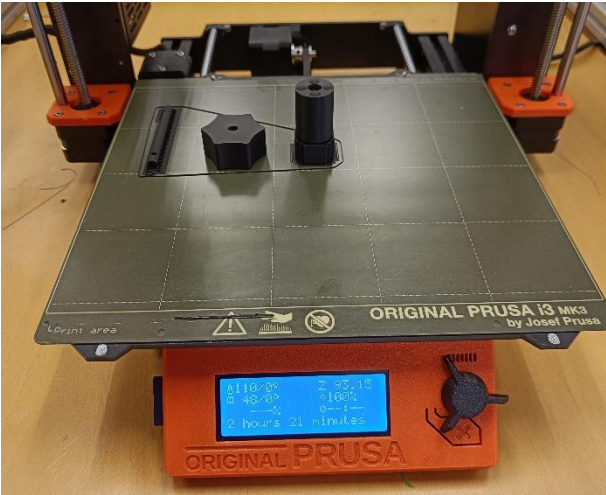

Figure 10, Finished prints

Concept 1

The main concern about this design was that milling the spheric profiles would not provide a satisfactory roundness, and thus not fit properly in the spheric grooves on the ICE 5. Given the assumption that the roundness of the machined part will be equal or better than the 3D-printed prototype, it is fair to use the prototype as a test object for the concept.



Figure 11, Rapid prototyping concept 1 & 2

The prototype was a great fit for the ICE 5, and the spheric profiles seem to fit very well. The bracket provides great torsional stability and is likely to relieve the bolt from a part of the shear forces, as well as inhibit bending moment in the bolt when the tool is held horizontally.

Concept 2

This design concept is primarily thought of as a backup in case the spheric profiles from concept 1 are not compatible with the ICE 5. It is more complex and more costly to manufacture than the design from concept 1, but it was considered more likely to be a match due to the (near) perfect roundness of the steel balls. The prototype was a great fit. It operates and performs identically as the prototype for concept 1. Given the equal performance and more tedious manufacturing and assembly compared to concept 1, it seems to be a lesser option.

Concept 3

Testing of this concept indicates that the clamp design might not be able to grip the ICE 5 sufficiently. There is only a frictional force preventing the ICE 5 from turning. Due to the location of the cylindrical section of the ICE 5, this bracket grips the tool far away from the center of mass, making the handling more tedious and making it prone to slipping.

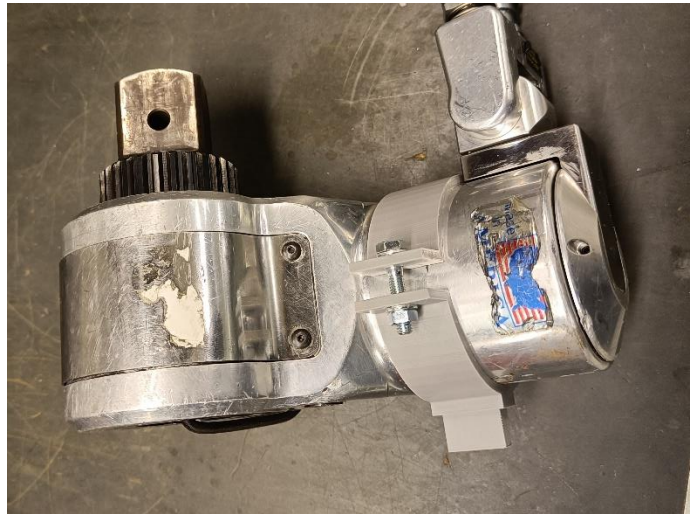

Figure 12, Rapid prototyping concept 3

Due to the prototype being produced in a different material than the final bracket would have, the friction coefficient between clamp and tool during testing is not equal to what it actually would have been. The friction can also be further increased by adding a rubber gasket to the inside of the clamps.

Concept 4

This concept seems to be a stable and rigid solution. The negative part is that it takes longer to reposition and assemble. The positive part about the clamp design was the simplicity and efficiency, and that is lost when adding the plate and bolt fastener. The key for the bracket is that it is as user friendly as possible, considering that one will have to detach and reattach the ICE 5 every time one switches from loosening to tightening direction.



Figure 13, Rapid prototyping concept 4

Lift mechanism concept selection

For the lifting mechanism it was not viewed as beneficial to do rapid prototyping. Concept scoring matrix (table 8) in combination with customer decision are the techniques used.

Table 8, Concept selection matrix – Lift mechanism

Selection criteria	Spring coil piston no preload (reference)	Spring coil piston w/preload	Rack and pinion w/tripod	Floor prop w/tripod
Ease of use	0	+	-	-
Ease of handling	0	0	-	-
Ease of manufacture	0	0	-	+
Performance	0	+	0	-
Stability	0	0	+	+
Safety	0	0	+	+
Weight	0	0	-	-
Robustness	0	0	0	0
Servicability	0	0	0	0
Cost	0	0	0	0
Sum +'s	0	2	2	3
Sum 0's	10	8	4	3
Sum -'s	0	0	4	4
Net Score	0	2	-2	-1
Rank	2	1	4	3

A matrix was also generated for the choice of materials for the lift mechanism and main body (table 9).

Table 9, Material selection matrix

Selection criteria	Material		
	Aluminum	Stainless steel	Carbon steel (reference)
Weight	+	0	0
Corrosion	+	+	0
Price	-	-	0
Machinability	+	-	0
Strength	-	0	0
Availability	-	0	0
Sum +'s	3	1	0
Sum 0's	0	3	6
Sum -'s	3	2	0
Net Score	0	-1	0
Rank	1	2	1

Customer decision and feedback

For the final decision in the concept selection process a meeting was held with Daniel Tønning at Hytorc's facilities. The customer was given a thorough presentation of the different concepts in order to make a well-informed conclusion. The prototypes of the different attachment brackets were presented and demonstrated. The group also displayed the Inventor assemblies and screening matrices of both the attachment bracket and lifting mechanism concepts.

For the attachment bracket the Customer chose concept 1. Concept 4 was also very well received, given its sturdiness and clever attachment plate that aligns with the screw holes on the ICE 5. However, concept 1 was preferred due to its ease of use and shorter setup time.

For the lifting mechanism the tripod solution was initially the one the customer was the most interested in, due to experience with similar spring-loaded tools falling over during operation. After some discussion and reflection, it was concluded that due to the limited space and the obstructions located on the floor where the tool will be used, the tool would require too much floor space for such a solution. Therefore concept 2 with the preloaded spring piston was selected. Due to the problem with other tools falling over due to slipping on the floor, the group was challenged to try to make the foot grip the floor more effectively than the simple rubber cap that was planned at this point.

6.2.5 Final concept specifications and features.

At this point the group selected the final concept specifications and features. From the chosen concepts to pursue, the desired specifications and features were refined. By deciding to pursue Attachment bracket – concept 1 and Lift mechanism – concept 2, the group made their decisions based on these two factors:

- Keeping highest ranking
- Discarding the ones that was not relevant to selected concepts

Different trade-offs were made to facilitate the final concept. Designing, calculations and testing were determining factors of what the values of these specifications and features at the end was going to be.

Table 10 shows the metric list for the final specifications and features.

Table 10, Final concept specifications and features, metrics list

Metric No.	Metric	Unit	Value
1	Load capacity	N	
2	Total mass	kg	
3	Longitudinal adjustability	mm	
4	Manual force applied to operate	N	
8	Foldable ability	Subjective	
12	Height	mm	
13	Cost per unit produced	NOK	

After combining the chosen concepts, a combined assembly was made (figure 14).



Figure 14, Final concept

Self-reflection of the concept development process

To reflect on the outcome of this process the group conducted the self-interviewing process, these were the questions and answers.

Is it necessary to gather more data?

- No, at this point of time the group view the amount of collected raw data to be sufficient. The data collected and processed created a good foundation to generate multiple concepts out of.

Were the customer needs fully understood?

- The group are confident as to understanding the customer needs. Having the interview where the customer could express their desires without being restricted, and at the same time for the group to ask questions back if ever confused, made understanding each other easier, and consequently the needs to be understood.

Did the group approach this process the right way?

- Regarding the gathered and interpreted raw data, the group view the process of interviews and action based research-data to be a good strategy and a right way to approach this process. These data laid the foundation of generating multiple different concepts for the needs. Testing these concepts by rapid prototyping and applying screening matrices, made the group to trust their decisions of the final concepts.

How can this process be improved?

- There is always room for improvement. One could for example get information from competing firms to Hytorc or confer with a group of wind turbine technicians with bolting experience. Putting more time into this process could've brought better concepts but could also be unnecessary, it's a trade-off.

6.3 Design and dimensions

After deciding upon a concept, there is still more to be done to the design before ending up with the final product specifications. Through the concept generation and selection rough ideas of the final designs were made, but before production ramp they need further improvement and more thoroughly thought through solutions.

6.3.1 Piston and main body tubes

When choosing the pipe diameters for the pipes that make up the piston and main body, it was crucial to choose dimensions that were compatible with the standard parts that were to be bought. Before having enough data to get a precise calculation, the group made a rough estimate that the complete mass of the support tool and bolting tool would be approximately 16,5kg. After some quick calculations based on assumed weights and lengths, it was concluded that the piston spring should have a spring constant around 0,8N/mm and a length between 350 and 450 mm.

After checking out different suppliers, it the group concluded that they should find a spring from fjaer.net, a very specialized supplier with an enormous selection of springs in different varieties. Two springs were ordered, model 23520 and 13520. The spring data is shown in table 11.

Table 11, Spring data (Sodemann Fjær, n.d.)

Spring data				
Measurement			Model	
Symbol	Metric	Unit	23520	13520
d	Thread diameter	mm	3,2	3,2
De	Outer diameter	mm	43,2	43,2
Di	Inner diameter	mm	36,8	36,8
L0	Initial length	mm	405	405
Ln	Fully compressed length	mm	84,5	84,5
Sn	Max displacement	mm	320,5	320,5
Fn	Force at Ln	N	240,17	288,32
k	Spring constant	N/mm	0,75	0,9

Focusing on the outer diameter of the springs, it was apparent that the inner diameter of the *Outer piston tube* would have to be minimum 43,2mm plus reasonable clearance. By making design decisions in this order, it was made easy to find standard components that would fit the tool. Using this information, different suppliers of steel pipe were explored. From Norsk stål, a set of pipes were found promising for this use (table 12). For the concept to work, the pipes needed to fit in each other with a reasonable clearance. If the clearance is too big, there will be too much movement and too large range

of angular motion in the pin joints holding the sections together. By having too little clearance there's a risk of the pipes not fitting due to them not being manufactured with fine tolerances.

Table 12, Pipe geometry (Norsk Stål, n.d.)

Steel pipe				
Model name	Use	OD[mm]	t[mm]	ID[mm]
312671	Inner piston	42,40	2,60	37,20
234816	Outer piston & top tube	51,00	2,60	45,80
312673	Main tube	60,30	2,90	54,50

Pipe threads

Before ordering the pipes it also had to be made sure that the pipes chosen had a fitting diameter and a sufficient wall thickness to be threaded with an existing thread type that would be easily programmable. By cross checking the geometry of the pipes that would require female threads and the different thread types and their requirements from the *Verkstedshåndbok*, it could be concluded whether the pipes were suited for the purpose or not (Hartvigsen et al., 2022, p. 135). It was discovered that the pipes were indeed suitable, and that the *Inner piston tube* could be designed with M39x1,5 and that the *Outer piston tube* could be designed with M48x2 (Hartvigsen et al., 2022, p. 135).

6.3.2 Attachment bracket

The attachment bracket was concluded to be based on the design Hytorc use for their handles. As Hytorc Norge are not involved in manufacturing these, there were no measurements or digital models available for copying the dimensions from. Hytorc supplied a pair of handles for the group to measure and disassemble in order to get precise dimensions. The handle was cut with a band saw and then the steel balls were measured with a caliper, as seen in figure 15. The goal was to find the right position, curvature and depth of the spheric profiles that were to be machined on the attachment bracket.



Figure 15, Measuring steel ball from Hytorc handle

The second approach was to do measurements on the ICE 5 itself. As the dimensions of the spheric grooves are quite small, and there's no edges to rest the caliper on, it was challenging to get accurate results.

The best solution came when Hytorc supplied the group with a STEP-file of the ICE 5 (figure 16). The depth of the grooves was not in the model, but the diameter of the grooves and the distance between them was easy to extract. The exact depth was found by measuring with proper tools at Aarbakke.

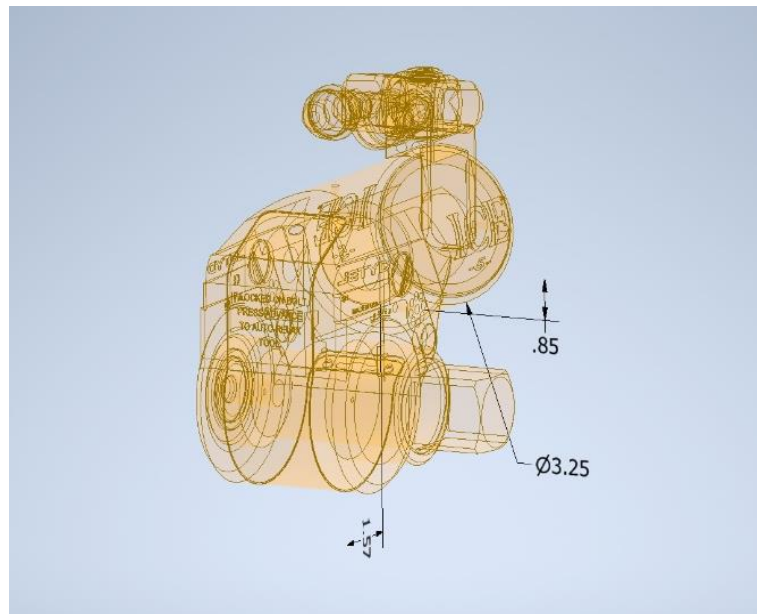

Figure 16, Finding different dimensions from STEP-file

6.4 Calculations

For the parts that are put under the most stress, it is important that they are analyzed and dimensioned to withstand yield conditions. Most calculations displayed in this chapter are just shown by the main formula and the result. More in depth information about calculations can be found in the MathCad document in Appendix G.

Table 13 shows the materials used for the different parts:

Table 13, Material properties (ASM,n.d.), (Steelconstruction,n.d.), (Steelnumber, n.d.)

Material	Area of use	Yield strength in relevant thickness [Mpa]
316L	C-bracket	205
S235JRH	All pipes	235
S355	Remaining machined components	355

All safety factors are given by:

$$SF = \frac{\sigma_{yield}}{\sigma_{max}}$$

Formula 1, Safety factor

6.4.1 Initial spring calculations

As mentioned earlier in the thesis, the spring for the piston was the first item decided on for the product development. The initially assumed total mass of the support tool and ICE 5 was estimated to be 16,5kg. As decided on in the concept selection, the piston should be at static equilibrium when the ICE 5 is held in working position. In other words, it should carry the weight of the ICE 5 without compressing, while still being easy to further compress in order to get the ICE 5 into working position. By solving the spring formula from Hooke's Law for displacement, while the spring force is equal to the weight of the ICE 5, the equilibrium point can easily be found. The spring data for model 13520 is used.

$$k = Fx$$

Formula 2, Hooke's Law

$$x_{eq} = \frac{k}{W_{tot}}$$

Displacement at equilibrium: 180mm

By subtracting this the displacement from the initial length of the spring, the optimal piston length is found.

$$L_0 - x_{eq} = L_{piston}$$

Required piston length: 225mm

6.4.2 Buckling

For an axially loaded slender structure such as this tool, it is important to dimension it for buckling. The structure has multiple cross sections throughout the length, so the normal set of buckling equations will not be sufficient for a precise analysis. There are iterative methods to quite precisely calculate the failure criterion for members with varying cross-sections, but the simplest method in use is to calculate the Euler load for the structure with a constant cross-section equal to the minimum cross-section throughout the whole structure. If the Euler load from this calculation is satisfactory, there is no need to go through the additional steps of iterative methods for multiple cross-sections.

$$F_E = \frac{\pi^2 EI}{(KL)^2}$$

Formula 3, Critical Euler load

In order to calculate the Euler load, the critical force under which the structure will fail, one must find the correct K value. K represents the column effective length factor, given by the support conditions of the member. The foot of the tool is fixed in x, y and z direction, but is free to rotate with 3 degrees of freedom. When in operation, the socket on the hydraulic torque wrench will deny the support tool any rotational movement and will also deny any translation in the horizontal plane. This coincides well with the 3rd Euler case, which is a member with one fixed support and one pin support. The 3rd Euler case gives a value of K=0,7 (figure 17).

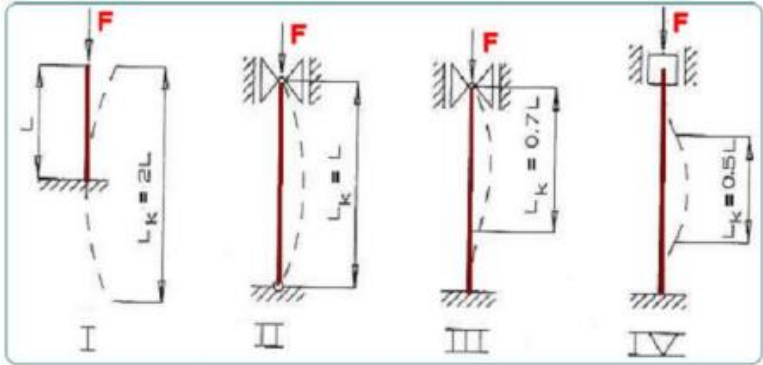

Figure 17, Euler buckling conditions (Lemu, 2021, p. 33)

By plugging in all the values, the result is a Critical Euler Load of 115,7kN.

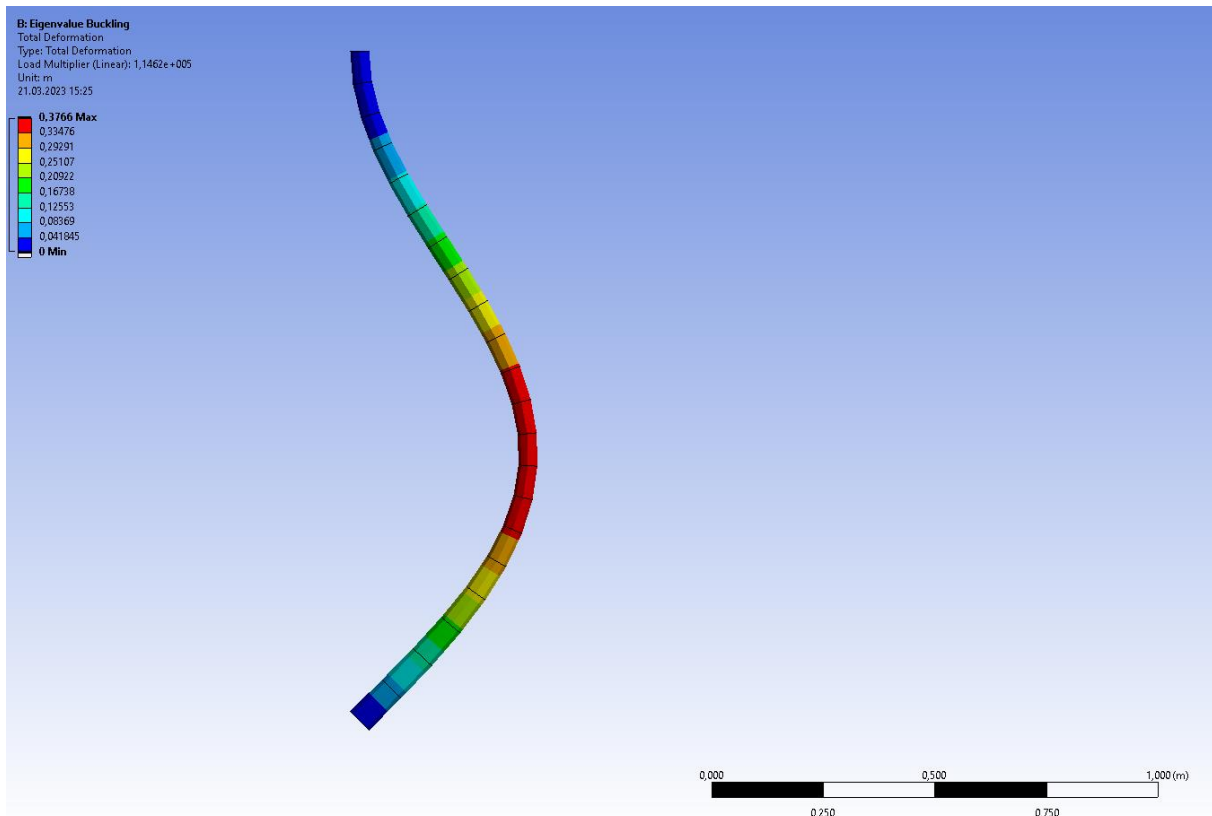

Figure 18, Ansys buckling calculation

The results from Ansys can be seen in figure 18. From calculations using Ansys Mechanical the Critical Euler Load was 114,6kN. It was modelled after the same boundary conditions as described earlier. For the top node all degrees of freedom (DOF's) are fixed except of translation along z-axis, for the bottom node all 3 translative DOF's are fixed, while all 3 rotational DOF's are free. Force applied downwards on top node. The shape shown in figure 18 is how the modelled member would deform at the critical Euler load.

The similarity of these results provides a reasonable basis to conclude that the results are correct.

Considering that the assumed maximum load the tool will be subjected to is 300N, the high safety factor from these results concludes that no additional calculations with more accuracy are needed. Calculating the critical Euler load for an accurate model with respect to the different pipe cross-sections would yield a higher value. The results show that the tool would be very safe against buckling when calculated with the minimal cross-section and will have an even higher safety factor in reality.

6.4.3 C-bracket

The C bracket is the tool component that is most prone to bending and potentially plastic deformation. It is necessary to calculate the maximum potential stress in the bracket to be certain it will not deform. For calculating the maximum stress, one must combine the normal stress due to bending moment and the shear stress from the vertical load. The vertical load will turn into normal stress where the C-profile turns vertical. Maximum equivalent stress will occur when bending moment is at max and when shear stress is still present. This is because the shear and normal stress are equal, and the $\sqrt{3}$ multiplier for shear stress in the von mises stress formula. Dimensions can be seen in figure 19.

$$\sigma_e = \sqrt{\sigma^2 + 3\tau^2}$$

Formula 4, Von Mises equivalent stress

$$\sigma_{max} = \sqrt{\left(\frac{M_b C}{I}\right)^2 + 3\left(\frac{F_z}{A_{cs}}\right)^2}$$

Hand calculations:

Equivalent stress: 56,27MPa

Safety factor: 3,64

Ansys Mechanical:

Equivalent stress: 65,07MPa

Safety factor: 3,15

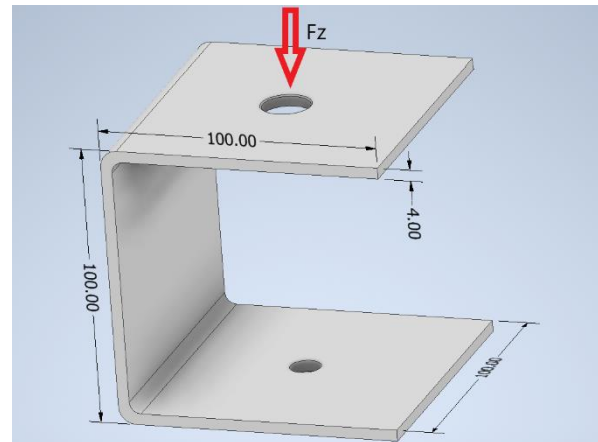

Figure 19, C bracket load and dimensions

Figure 20 shows the location and magnitude of the highest stress in the structure.

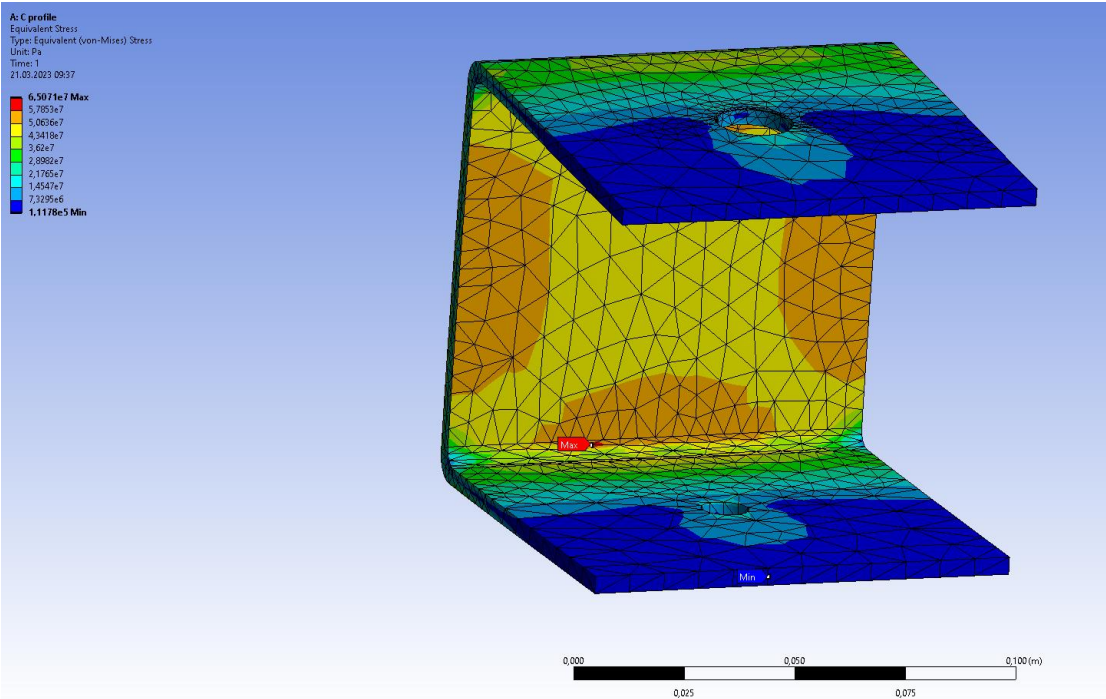

Figure 20, C bracket equivalent stress concentration

From Ansys the maximum displacement due to deflection was also calculated. Figure 21 shows that at the maximum load, the end of the C-profile has a displacement of -0,18mm in z-direction.

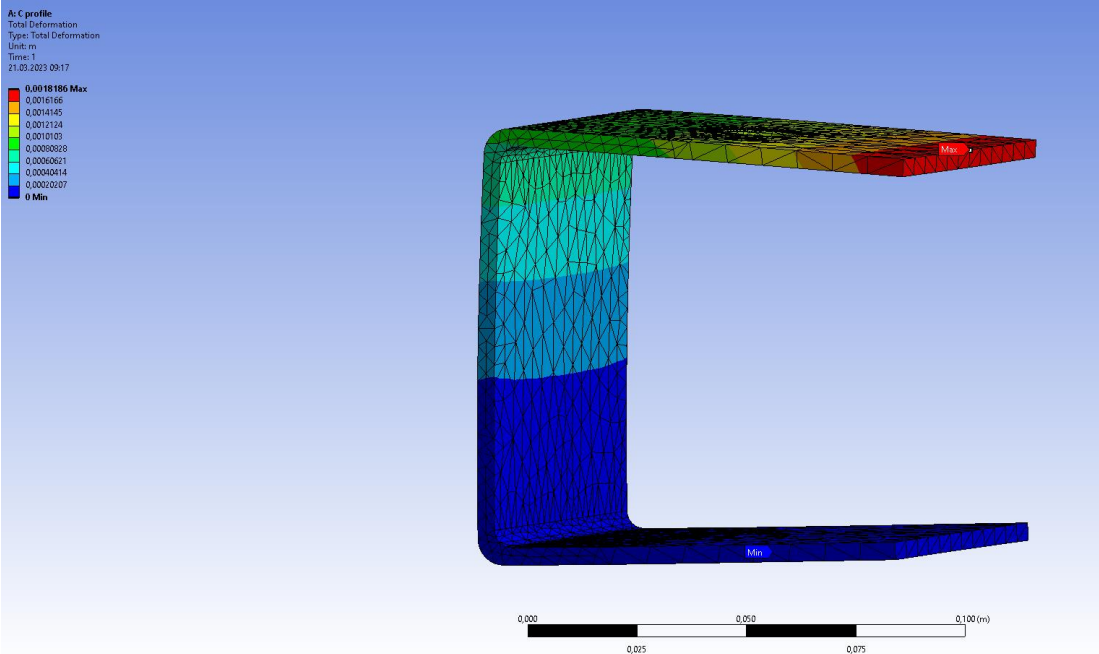

Figure 21, C bracket maximum displacement

The analysis was made by applying a fixed support on the inside of the lower hole and applying the force on the face around the top hole.

6.4.4 Clevis pins

Max stress occurs in the lower clevis pin that connects the piston to the *Main tube*. The max load is set to be equal to the spring force at full compression. Since the load is distributed over 2 points, the cross-sectional area is doubled in the calculation.

$$\tau = \frac{V}{A}$$

Formula 5, Shear stress

$$\tau_{pin_{max}} = \frac{F_{spring}}{2A_{cs}}$$

Max shear stress: 7,00MPa

Safety factor: 33,6

6.4.5 Attachment bolt

Due to the design of the attachment bracket, it's been concluded that the attachment bolt must only withstand stress due to shear forces, not stress due to bending moment. The attachment body has a large face contact area with the ICE-5, and because of the spheric profiles it will be locked and unable to unscrew itself during operation. The spheric profiles prevents the ICE-5 from turning and will resist both torsional and shear forces. Since the face of the ICE-5 and attachment body will always be in contact, there is little to no bending moment that is taken up by the bolt. On this basis it has been concluded to only review the shear stress in the bolt. The maximum shear force during normal operation will occur if the tool is held fully horizontally and the weight of the ICE-5 is working perpendicular to the bolt.

For calculations done before correcting the load assumptions, the stress was significantly higher when bending moment was present. After correcting this the stress in the bolt is quite low.

$$\tau_{bolt_{max}} = \frac{W_{ICE\ 5}}{A_{bolt}}$$

Max shear stress: 6,41MPa

Safety factor: 32

6.4.6 Piston lock

The relationship between the thread clearance and inner diameter of the Piston lock creates a thin wall. Ø45 and Ø43,3 results in a wall thickness of only 0,85 mm (figure 22). There was a concern that when tightening the piston lock to its counterpart, the shear stress generated by the torque could cause the wall to fail.

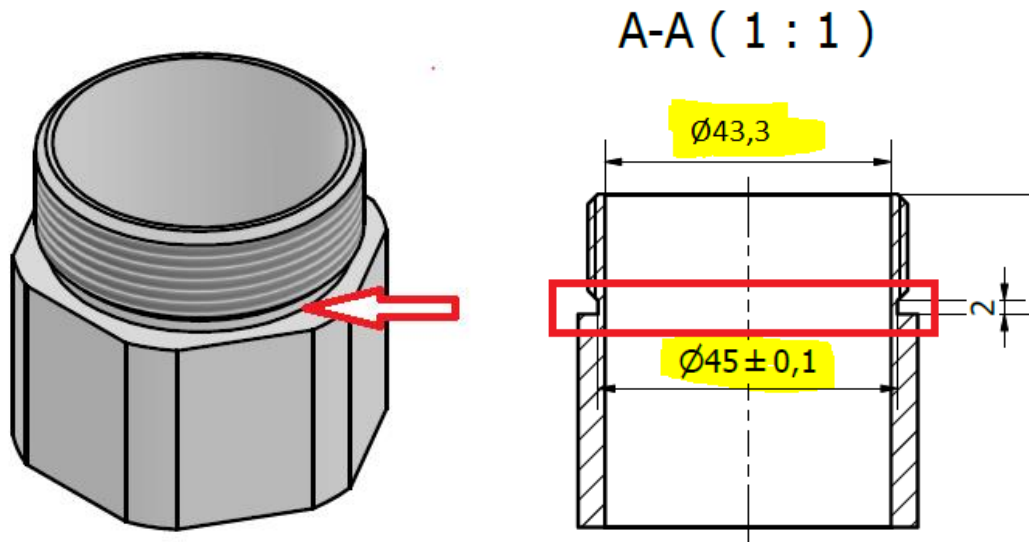

Figure 22, Piston plug dimensions

Torque applied when assembling is supposed to be sufficient to keep it from unscrewing itself. The sufficient torque is assumed to be slightly over “hand tight”. After some research on the subject the group concluded that “hand tight” is approximately 30-50 Nm (Wade, n.d., para. 2). If this is assembled with a wrench, it is fair to say that torque will be higher than hand tight. When torquing wheel nuts on a car, the torque is approximately 120 Nm (Continental, June 2015, p. 1). This torque is assumed to be higher than what is applied to the Piston lock when torqued with a wrench, so if the calculations of stress with 120 Nm applied is within limits, one can with great confidence say that the thin wall will not fail.

Simplified calculation:

Consider the object to be a hollow circular cylinder consisting of OD45mm and ID43,3mm

$$\tau_{PL_{max}} = \frac{Tc}{J}$$

Formula 6, Shear stress due to torsion

Hand calculations:

Max shear stress: 46,98MPa

Safety factor: 7,6

Ansys simulation (figure 23):

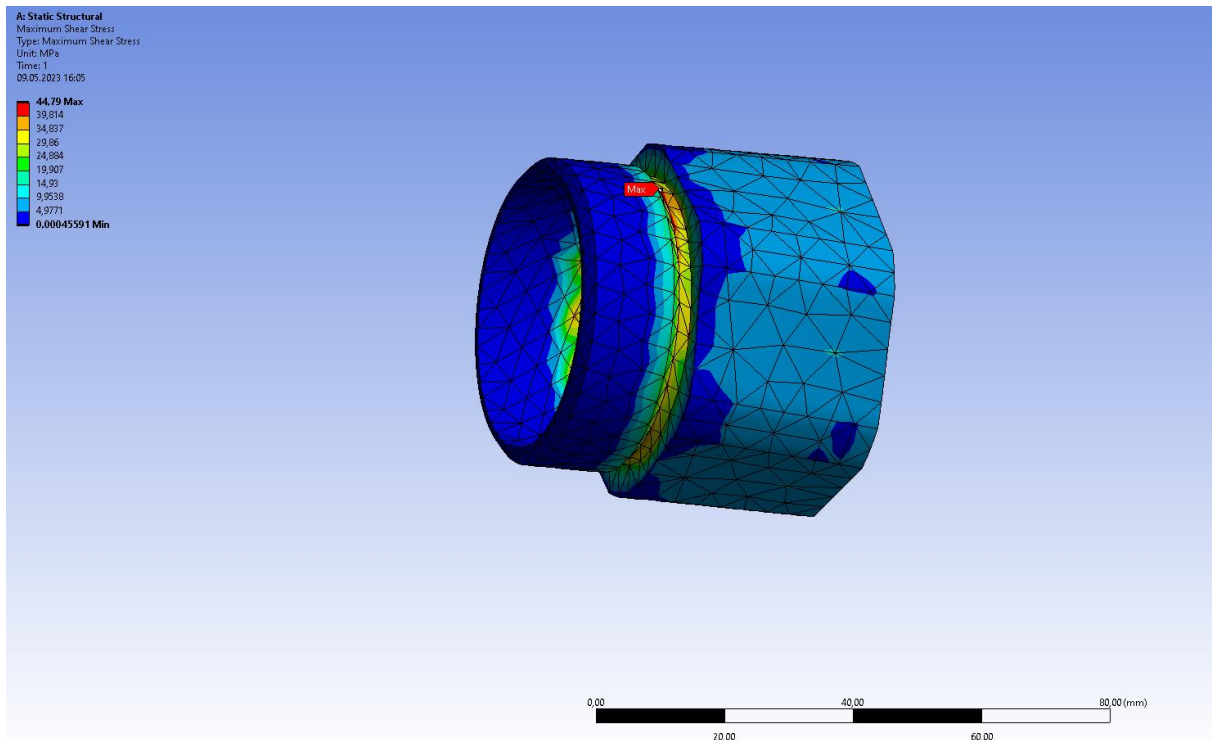

Figure 23, Piston plug equivalent stress concentration

Ansys results:

Max shear stress: 44,79MPa

Safety factor: 7,9

From hand calculations and Ansys simulation, max shear stress is at 46,98 and 44,79 MPa due to torsion, this is way under the yield strength of 355MPa. The torque applied when assembling the Piston lock is ok and will not cause failure to the thin wall of the thread clearance.

6.5 Manufacturing the Support Tool

Manufacturing the Support Tool required multiple different manufacturing processes. Both UiS workshop and Aarbakke's manufacturing plant were used. Machining, welding and additive manufacturing was the main processes of manufacturing. In this chapter the group first explains the use of the Manufacturing Plan. Manufacturing of every designed part will then be described. At the end of the chapter there is a section of relevant HSE.

6.5.1 The Manufacturing Plan.

To secure a steady workflow, a plan must be laid for the components that will be manufactured. A plan that at minimum consists of how and when. How to manufacture the component and when to do it. The product doesn't need to be of high complexity for it to be impossible to manufacture if one does not use the right order of manufacturing. When manufacturing a product consisting of many individual parts, it can be challenging to keep track and remember the right order of production of every part.

This is why the group developed a Manufacturing Plan. The manufacturing plan was used for manufacturing every individual part. All manufacturing plans are attached in the appendix H. The manufacturing plan essentially laid out the path of production. What to do and in what order. Table 14 is an example of how a manufacturing plan for one part looked like.

Table 14, Manufacturing plan - Inner piston tube

Part:		Inner piston tube															
DWG no.		SM-Bsc-015															
Rev:		1															
<table border="1"> <thead> <tr> <th>No.</th> <th>Process:</th> <th>Information:</th> </tr> </thead> <tbody> <tr> <td>1</td> <td>Band saw</td> <td>Cut material OD42,4 pipe to 305mm length</td> </tr> <tr> <td>2</td> <td>Machining</td> <td>Lathe, turn internal thread M39x1,5. chamfer and full length 300mm.</td> </tr> <tr> <td>3</td> <td>polishing</td> <td>May need a polishing-operation of the OD to be able to glide properly with the ID of "piston lock".</td> </tr> <tr> <td>4</td> <td>Assembly</td> <td>Assembling to Part 13.</td> </tr> </tbody> </table>			No.	Process:	Information:	1	Band saw	Cut material OD42,4 pipe to 305mm length	2	Machining	Lathe, turn internal thread M39x1,5. chamfer and full length 300mm.	3	polishing	May need a polishing-operation of the OD to be able to glide properly with the ID of "piston lock".	4	Assembly	Assembling to Part 13.
No.	Process:	Information:															
1	Band saw	Cut material OD42,4 pipe to 305mm length															
2	Machining	Lathe, turn internal thread M39x1,5. chamfer and full length 300mm.															
3	polishing	May need a polishing-operation of the OD to be able to glide properly with the ID of "piston lock".															
4	Assembly	Assembling to Part 13.															
Remark:																	

6.5.2 Manufacturing each individual part

Piston lock stopper

This part needed to be machined before the *Inner piston tube*, because of limitations of measuring tools available. The workshop at UIS did not have internal threads measuring tools but did have for external threads. By machining *Piston lock stopper* first, one could use the thread of the part as gauge for the internal thread of the *Inner piston tube*.

The material for *Piston lock stopper* was cut to length 54mm in the band saw. The material was then ready to be machined in the CNC Okuma lathe (figure 24). The part was turned and threaded, then verified for correct size of the external M39x1,5. Dimensions 2 and 11 were changed to 3 and 10 (drawing in Appendix B), it had to be done because of available machining inserts at UIS. When machining was done, the part was deburred (remove the sharp edges) and threads polished.



Figure 24, Manufacturing - Piston lock stopper

Inner piston tube

The material was first cut to correct length in the band saw. Then the Okuma CNC lathe at UiS was used to machine the part. *Piston lock stopper* (the counterpart) was manufactured prior to this, so it was used to gauge the internal M39x1,5. Dimension 15 was changed to 16 (drawing in Appendix B – Figure B-3), because of the modifications of the *Piston lock stopper* dimensions. On the pipes there was a protruding weld on the ID along its axis, this could be a hazard and caution was taken when machining. The pipes were slightly deformed due to the clamping force of the chuck and thin pipe wall. The clamp force was reduced 50% when running the next pipe. After machining the part was deburred.

Outer piston tube

Material was first cut to specific length in the band saw. The material was then ready for machining and clamped in the chuck of the Okuma CNC Lathe at UiS for turning the internal M48x2 (Figure 25). The counterpart, *Piston lock*, was machined prior to this to be able to gauge the internal M48x2. Dimension 22 was changed to 25,5 (drawing in Appendix B – Figure B-4) because when gauging the M48x2 with *Piston lock*, approximately 3mm length remained for the *Piston lock* to touch the face of the *Outer piston tube*. After running the thread to 25,5 length and again checking with the *Piston lock*, it still had 3mm to go before touching, the problem seemed to be in the *Piston lock* itself. The group noticed some burrs in the thread which potentially could be the source of the problem. The group fixed this issue by printing a *Washer* with a slightly longer length than 3mm, so that the *Piston lock* could touch onto this *Washer* and covering the 3mm gap. The part was later drilled $\text{\O}7$ thru hole in the Mazak Nexus 510C milling machine at Aarbakke. The internal threads were deburred and polished.



Figure 25, Manufacturing - Outer piston tube

Piston lock

The material was cut to correct length in the band saw.

Machining the part was done at Aarbakke in the CNC Mazak Quick Turn 100MY lathe, as seen in figure 26. Deburring and polishing of the threads was performed at the end.

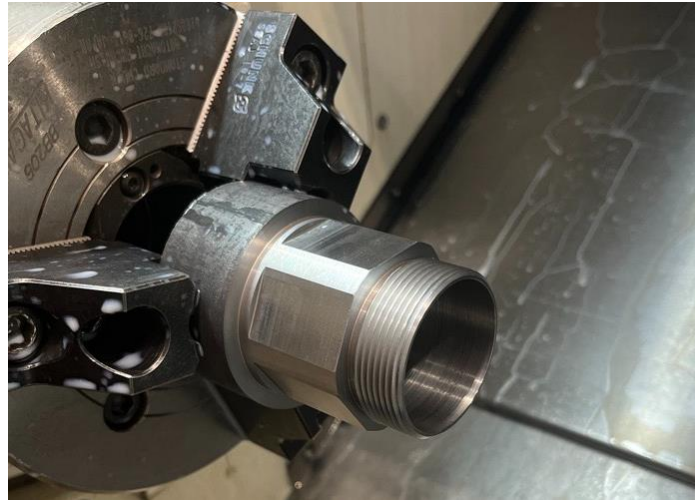

Figure 26, Manufacturing - Piston lock

C-bracket

The material for this part was a square tube. The material was cut to correct length. Then the part was machined in one machine, but in two operations, meaning clamping the part then machine a feature, then unclamp flip the part over and clamp again, then machine next feature. The part was machined at Aarbakke, in the machine CNC Mill, Mazak nexus 510c, as seen in figure 27.

After machining in the mill, the wall was cut off in the band saw, creating the final “C-shape” of the part. Sharp edges were deburred. The corners where the wall was cut off, were grinded a slight radius for safety reasons.



Figure 27, Manufacturing - C-bracket

D2 threaded cap conn.

The material was cut to right length in the band saw.

Machining in CNC mill, Mazak Nexus 510C:

1. operation: milling both diameters and drilling holes for the thread.
2. operation: face off material to correct length, chamfer hole and corners and tap thread.

The thread on the drawing was initially drawn with M10x1,5 but the floating joint that was going to be attached to this has a M10x1,25. This deviation was discovered in the machining of the part, but before the actual thread was machined. So, the drawing was wrong, and the correct thread (M10x1,25) was machined on the part. The part is depicted in figure 28.

This part was welded when assembled to one of its counterparts (*Top tube*).

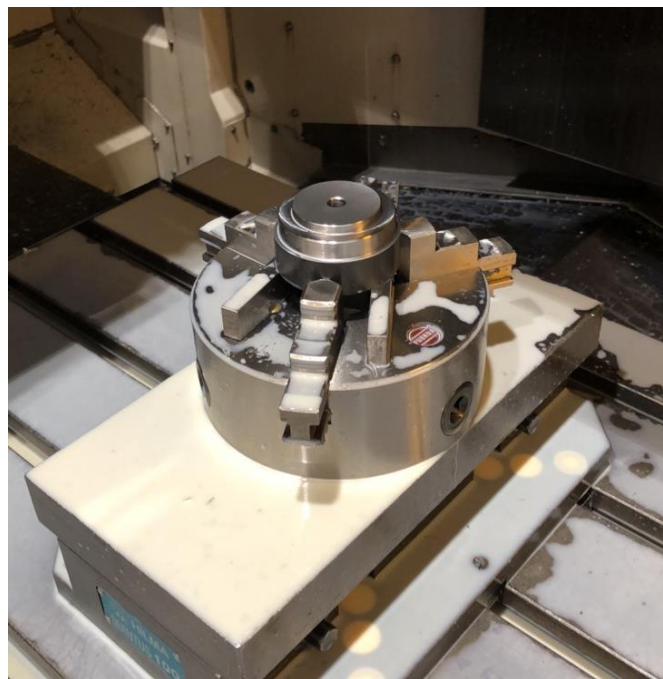

Figure 28, Manufacturing - Threaded cap connection

Clevis pin

Two *Clevis pin* were manufactured. First the material was cut to length.

The machining was performed in two CNC machines.

First, CNC lathe, Mazak quick turn nexus 250. Relevant dimensions were turned.

Last, CNC Mill, Mazak nexus 510c. The holes were drilled as seen in figure 29.

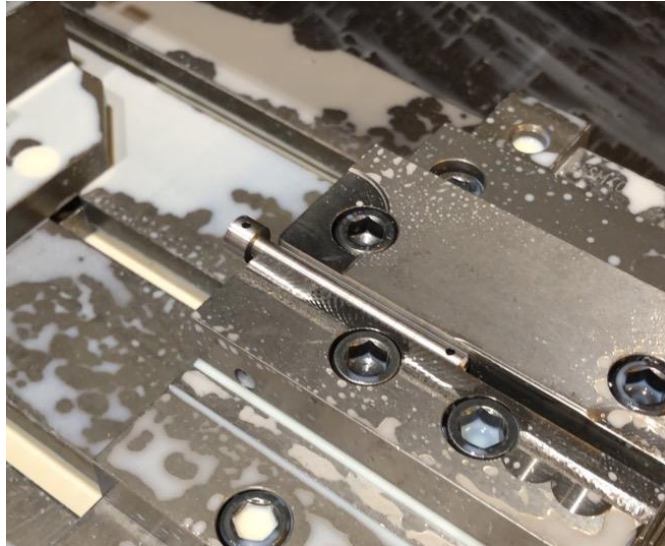

Figure 29, Manufacturing - Clevis pin

Attachment bolt

Material was first cut to correct length in the band saw.

Machining the part were performed in two CNC machines at Aarbakke.

Turning the part for the relevant dimensions in the CNC lathe, Mazak quick turn nexus 250. Turning, threading and cut off part, performed in a one operation.

Milling flat surface was then performed in the CNC Mill, Mazak nexus 510c. One operation.

Handle

The handle was manufactured with first AM, in the Markforged Metal X at UiS. The part file was exported as an STL and sliced in Eiger, the slicing software for Markforged printers. Then the part was printed. After printing the part was washed and sintered. Figure 30 shows the part in the printer, before wash and sintering.

After the ALM process, the part was machined. It was machined at Aarbakke in the CNC mill Mazak nexus 510c. For machining holes and threads the machining in the mill needed 2 operations.

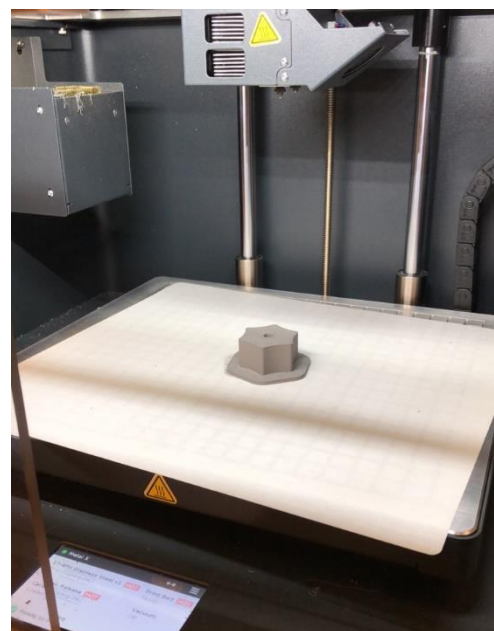

Figure 30, Manufacturing - Steel printed handle

Attachment body

Material was cut to length in the band saw.

Machining the part was performed at Aarbakke in two machines.

First, CNC lathe Mazak Quick Turn Nexus 250. One operation, turning relevant dimensions, threading and drilling $\text{Ø}6,3$ hole through part, the part shown in figure 31(left).

Last, CNC Mill Mazak Variaxis 730-5X II. One operation, 5-Axis milling of spheric-features shown in figure 31(right). After machining the part was deburred.

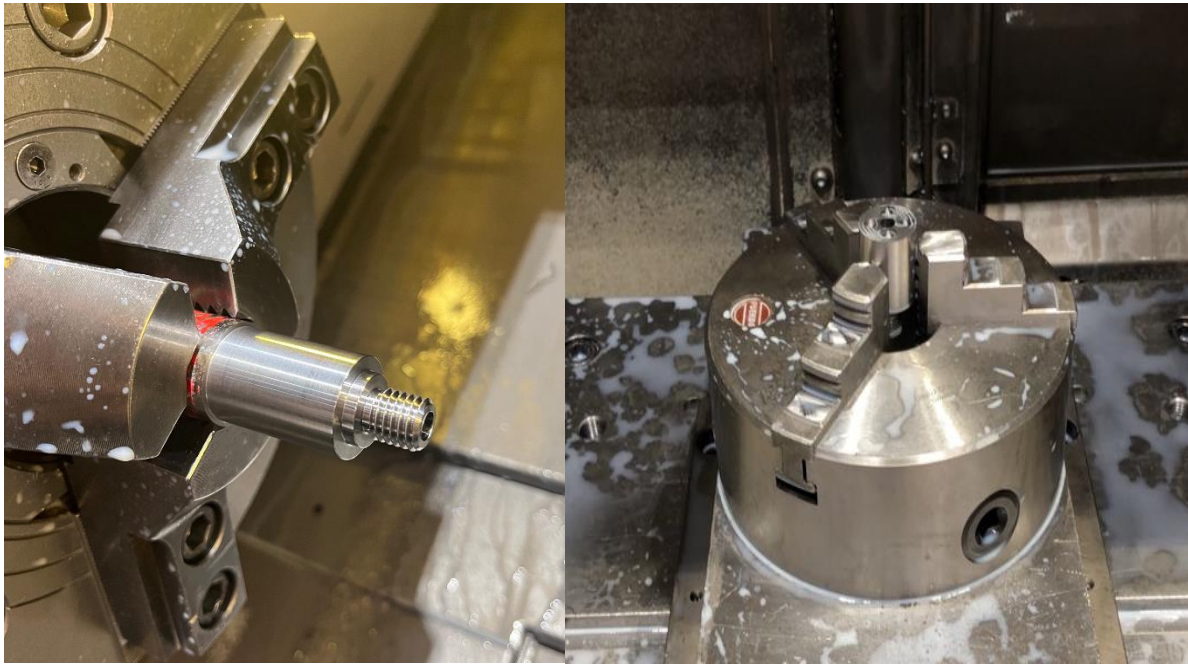

Figure 31, Manufacturing - Attachment body

Main tube

Material was cut to correct length in the band saw. The machining was done at Aarbakke.

The part was machined in the CNC mill, Mazak nexus 510c. This required two operations. The finished part was then deburred.

Top tube

Material was cut to correct length in the band saw.

The part was machined at Aarbakke in the CNC mill Mazak Nexus 510c. In the first operation the 8 holes were drilled. In the second operation milling the slot was performed, as can be seen in figure 32.

After machining the part was deburred.

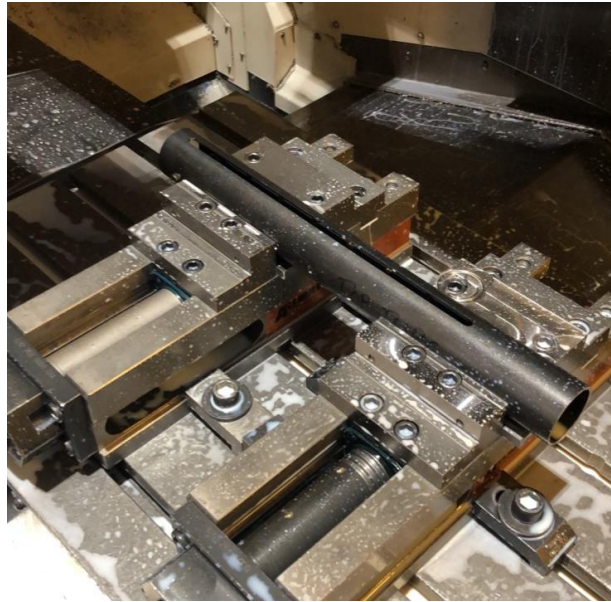

Figure 32, Manufacturing - Top tube

Welded piston plug

Material was cut to correct length.

The part was machined at Aarbakke in the CNC mill Mazak Nexus 510c.

First operation, milling OD of part.

Second operation, milling the rest of OD (figure 33).

Third operation, drilling hole through part.



Figure 33, Manufacturing - Welded piston plug

Additive layer manufacturing (ALM)

Spring support, Liner, Washer, TPU foot and *TPU retainer*(discarded) were manufactured by the 3D-printing at UiS. The Prusa i3 Mk3S was used to print the parts. The cad-files for the part were first sliced in the slicer-software for Prusa. Then the printing was performed.

Spring support, Liner and *Washer* was manufactured in the material PLA.

TPU foot and *TPU retainer* were manufactured in the material TPU.

After printing process, the parts were stripped of support materials for the parts relevant.

6.5.3 Health, Safety and Environment

This project is derived from a health concern perspective. Snorre's experience in the work scenario, enduring the stress of holding the heavy bolting tools, and therefore seeing the need for a support tool, confirms that health is one of the founding factors of this project.

Through this project the group has been in contact with machinery and tools that can be harmful and even life-threatening. To be able to work with such machinery the group has the required training and knowledge of the related HSE (Health, Safety and Environment) hazards. Working in the UiS workshop, they require all users to pass the "UIS workshop safety course". In addition to the course, when working with specific machines and tools in the workshop, a "SJA" (sikker jobb analyse) must be approved. A SJA is a document about the HSE-impact of using a specific machine/tool/method.

It is important when developing a product to be aware of the environmental effects of the product (Chryssolouris et al., 2022, para. 1). First in the sense of the function of the product. For example, does it run on fossil fuel, and therefore causes an environmental hazard, and consequently how large will the environmental footprint be (Chryssolouris et al., 2022, para. 1). Will this pollution cause the product to not be approved? Then, what environmental footprint does the project leave behind because of the actual developing of the product? Is the manufacturing of the product causing an environmental hazard? Will the project cause high consumption of resources, and what can be done to avoid excessive use of these resources?

Having a thought through plan will directly affect the consumption of materials, power and other resources, and assist to deal with the questions raised in the section above (Eppinger & Ulrich, 2012, p.231). By following the methods of a product development process and case study research, which will gain insight and consequently apply a strategic plan of approach, the project will cut the potential consumption of extra resources, leaving a smaller environmental footprint behind.

In this project, the consumption of resources has exceeded the estimates. Defects has occurred in the manufacturing and therefore used extra material and extra machining to replace it. Testing and refinement have uncovered issues with the product, which also lead to extra use of resources. This is a

common in developing a product, and the group view their extra use of resources to be at a low amount, much thanks to the strategic methods of developing the Support Tool before manufacturing (Eppinger & Ulrich, 2012, p.231). The benefits of rapid prototyping like having less waste – less material, machines require a low amount of power, all in which the group consider to be an environmentally friendly technique of the manufacturing conducted in this project.

6.6 Testing, refinement and results

During manufacturing, and after assembling the first version of the prototype, different challenges arose. To reach the goal of producing a well-functioning tool, the group made different changes and improvements to the original design.

6.6.1 Weight reduction

During testing it became clear that the initial assumptions regarding total tool weight in the early stages of design turned out to be wrong. The support tool is supposed to be able to carry its own weight and the weight of the ICE 5 when it's at the fully extended position. testing showed that the piston compressed quite a bit when the ICE 5 was mounted. This means that either weight must be reduced, spring must be exchanged to a stiffer version, spring precompression must be increased, or a combination of the above. Considering the request for a slightly shorter tool, the group decided to remove material from *Top tube* and *Welded piston plug*.

Top tube

The end of the part, connecting to *D2 threaded cap conn.*, will be cut off. The benefits of this material removal:

- Mass reduction makes a lighter tool.
- Shorten total length of the whole tool, as requested from Hytorc, shorten 70mm
- This modification does not create more work on other parts to the tool

Remove material, cut off by band saw operation 70mm from the top-end of the part. The section that will be cut off is illustrated in figure 34. Table 15 contain the properties of consideration to the material removal process.

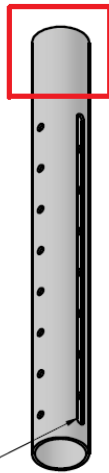

Figure 34, Weight reduction - Top tube

Table 15, Weight reduction – Top tube, properties

Property	Value
Material	S235
Density	7850 kg/m ³
OD	51mm
ID	45,8mm
Removal length	70mm

$$\Delta m = \Delta V \rho$$

Formula 7, Change of mass

Mass removed: 217g

Welded piston plug

Remove material from the center, bore Ø35 through part. Machining process mill or lathe. The volume planned to be removed is illustrated in figure 35. Table 16 contain the properties of consideration to the material removal process. Benefits for this material removal:

- Mass reduction of unnecessarily heavy part
- No modification of other parts needed

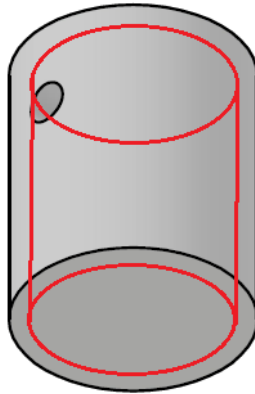

Figure 35, Weight reduction - Welded piston plug

Table 16, Weight reduction - Welded piston plug, properties

Property	Value
Material	S355
Density	7850 kg/m ³
Radius (of cutout)	17,5mm
Depth	54mm

Mass removed: 408g

Sum of mass removed: 625g

Increasing spring piston precompression

As the weight reduction itself is not sufficient to compensate for the lack of force from the spring piston precompression, a new spring was chosen. In order to calculate the correct piston length for the fully extended position, all the components above the lower piston tube were weighed to get a precise measurement. As the mass measurements were made before mass reduction, the calculations were compensated for this. In order to make the calculation fully precise, the equation must also compensate for the weight reduction for each millimeter the piston is shortened by to increase the preload.

Table 17, Data for calculating new equilibrium load

Description		Magnitude	unit
w	Weight per millimeter removed	0,0304	N/mm
L0	Initial piston length	282	mm
x0	Initial spring displacement	58	mm
W0	Total weight above inner piston tube	190,3	N
k	New spring constant	1,83	N/mm

To calculate the piston reduction, an expression must be made for the change of weight and increase in spring force. The data from table 17 is used to calculate the length of cut. The length of cut is represented as x.

$$W_0 - wx = k(x + x_0)$$

Solving this for x shows that the piston needs to be reduced by 45,4mm.

Final theoretical mass reduction: 766g

Actual final mass (torque wrench excluded): 7137g

6.6.2 Liner

When assembling *Top tube*, *Main tube* and *Outer piston tube*, the group realized that the connecting fit of these parts were too loose. In the designing phase the group was aware that the dimensions of these connections were going to be loose, but not quite sure how this would feel when assembled. The group was not satisfied with these loose connections. Different solutions were generated, and the most promising was to install a new part, the *Liner*. The function of the liner is to get a tighter connection with less “wobble room” but still have enough room for assembly and functioning reasons. It must let the *Top tube* to glide easily through the *Liner*. In Figure 36 one can see how the tool does not stay straight prior to modification. The *Liners* were manufactured by ALM at UIS and assembled directly. The fit and feel was satisfactory.



Figure 36, Need for liners

6.6.3 Pipes - dimensions

The pipes, all three sizes, were measuring quite different than the nominal sizes listed for their dimensions. This affected some of the dimensions of the parts. Most critically the threads M39 and M48. All 3 varieties had inner diameters larger than stated from the supplier. The diameter differentials affected the threads, as can be seen in table 18.

Table 18, Drill hole before tapping (minor dia.) in relation to actual hole (Hartvigsen et al., 2022, p.135).

Thread	Drill-hole, min tolerance	Drill-hole, max tolerance	Actual ID measured on pipe:
M39x1,5	Ø37,376	Ø37,676	Ø37,84
M48x2	Ø45,836	Ø46,21	Ø46,23

Looking at the table one can see that the actual IDs are out of tolerance for the related threads. The threads were machined with this deviation. The fit and feel with connecting parts were acceptable, and the group decided to proceed.

6.6.4 Pipes – seam weld

All pipes used in the Support Tool were welded pipes. This means that there is a weld seam through the length of the tubes, protruding from the ID. The group was not aware of this weld seam and did not take this into consideration when designing. This seam caused a problem with the *Piston lock stopper*. When the piston is compressing and decompressing, the group noticed that the *Piston lock* was interfering with the seam weld on the ID of *Outer piston tube*. By grinding the outer edge of the *Piston lock stopper*, the interference was reduced.

6.6.5 Piston lock

The fit between the *Piston lock* and *Inner piston tube* was a mismatch. It was too tight, and the *Inner piston tube* wouldn't slide through *Piston lock*. It was an unfortunate combination of the *Inner piston tube*'s surface (corroded and uneven) and slightly elliptic cross-section. The group discussed three different solutions for this problem:

- Machining of *Inner piston tube*'s OD. This could be done by the CNC lathe, manual lathe or a milling operation.
- Polishing of *Inner piston tube*'s OD was also debated. Though it was uncertain how much polishing it would require, this operation could be less time consuming than machining and were in favor.
- Last option was modification of *Piston lock*. Machining of its ID to a larger diameter. This was not a favorable option because of the thin wall created by the thread clearance which was already a concern.

After machining *D2 threaded cap conn.*, proper fixture and machining tools were already in the CNC mill, so the decision for modification of ID to the *Piston lock* was the solution the group chose. The thin wall measured 1mm prior to modification, and 0,85mm after ($\text{Ø}43,3$). It was an educated guess that this small removal of material would not be critical to the *Piston lock* when installed to the Support tool. Fit and feel after modification was a success. Calculation of torsional stress at this wall was made after machining to control the educated guess in the machining process. The CNC mill, Mazak nexus 510c at Aarbakke, was the machine used when modifying this part.

6.6.6 Attachment bolt and Handle

There was a change of design to the *Attachment bolt* and the connecting part, *Handle*. Originally a M3 bolt was intended to keep the *Attachment bolt* connected to the *Handle*. The standard blind M3 tap is not long enough for the thread depth on the *Handle* drawing. The new solution for connecting these two parts together was by a M6 set screw against a flat surface. An M6 thread where machined in *Handle*, and flat surface machined on the *Attachment bolt*. Relevant revision changes were made to their drawings.

6.6.7 Attachment body

On this part there was made multiple design changes and therefore the number of revisions on the drawing. Some preferable changes of dimensions like, thread clearance, larger OD and other minor dimension changes were discussed and performed.

When the group was ready to machine the part, they first double checked the dept of indented spheric features of the ICE 5 were the spheric features of the Attachment body would connect. At this point of time, the group had available better measuring devices than prior. The group measured the indents to be different than prior estimates. Dimensions of Attachment body were therefore altered, the spheric features were changed to $\text{Ø}4,8 - R2,4$, to apprehend the deviation of measurement to prior estimates.

A *TPU retainer* fitted in a countersink of the *Attachment body* was intended to keep the *Attachment bolt* in place when assembled. This design was never manufactured because the group discussed and applied another design. The new and favorable design was to have a steel ball protruding into the bore of the Attachment body from the side, pressing against the bolt with spring force. The ball and spring were held in place by a set screw. This would allow for an easier mounting of the *Attachment bolt* to the *Attachment body*. The *TPU retainer* was discarded, and relevant design changes were updated on the parts drawings with new revision numbers.

6.6.8 Allowing angular movement for the wrench

After some testing it was concluded that the support tool would be easier to use if it would allow the wrench to move a bit more freely while mounting it on the bolts. Allowing some additional “wobble room” would make the operation of mounting the wrench easier and faster. Different alternatives were sought, and the group decided they should search for an existing part that could solve the problem. The part should allow rotational movement with 3 degrees of freedom, but with a limited range of motion. A lot of different, existing solutions were researched. The most fitting solution was a floating joint (figure 37), as it could easily be installed on the tool without a lot of additional modifications. It allows for rotational movement with 3 degrees of freedom and has a restriction of only 5 degrees deflection from the center axis. These specifications were perfectly aligned with the ones the group searched for, and the component was purchased. (RS, n.d.)

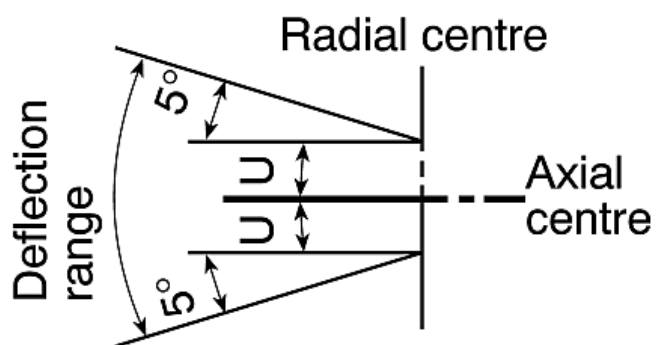

Figure 37, Floating joint (RS, n.d.)

After receiving the *Floating joint*, it became apparent that the deflection range was not as listed. The joint had a much larger range of motion than described, and a solution had to be found to restrict the motion to an acceptable level.

By exchanging the nut shown in the picture with a wider, thicker one, it would limit the deflection range by physically interfering with the edge of the floating joint.

Measuring the standard nut in relation to the distance of the ball joint, the group estimated that a nut with extra width and a thickness of about 2mm larger than the depicted one would be ok. The group quickly machined a thicker nut, installed it, and testing the range of motion gave good results. CAD file and drawing of the new nut, *Tall nut – M10x1,25*, was made later.

6.6.9 D2 threaded cap conn.

When installing the Floating joint to the *D2 threaded cap conn.*, the standard hex bolt connecting these two parts was slightly shorter than the group wanted. The longer bolts available on the market were too long, so the group had two options:

- Buy the longer bolt and modify its length.
- Modify the thickness of the D2 threaded cap conn.

Investigating the second option further, the group discovered that by shortening the thickness by 2mm, the hex bolt would fit deep enough into the *Floating joint*. This option was chosen, and the group modified the *D2 threaded cap conn* in the CNC milling machine, facing off the thickness by 2mm. Subsequent testing gave good results. The drawing of *D2 threaded cap conn.* was then updated with new revision.

6.6.10 Results

After all the modifications were executed, the final prototype was made. Table 19 shows the final specifications. Figure 38, show the final prototype in its shortest length setting, while the subassemblies and the tools needed for mounting are shown in figure 39.

Table 19, Final specifications.

Metric No.	Metric	Unit	Value
1	Piston preload	N	189,2
2	Weight	kg	7,136
3	Length adjustability	mm	270
12	Height (max.)	mm	1490

Videos were made of how to assemble the tool as well as a couple of short, informative videos of some of the solutions and mechanisms.

Assembly demonstration:

<https://vimeo.com/826660469>

Need for the floating joint:

<https://vimeo.com/826663427>

Bolt retainer mechanism:

<https://vimeo.com/826662487>



Figure 38, The Support Tool

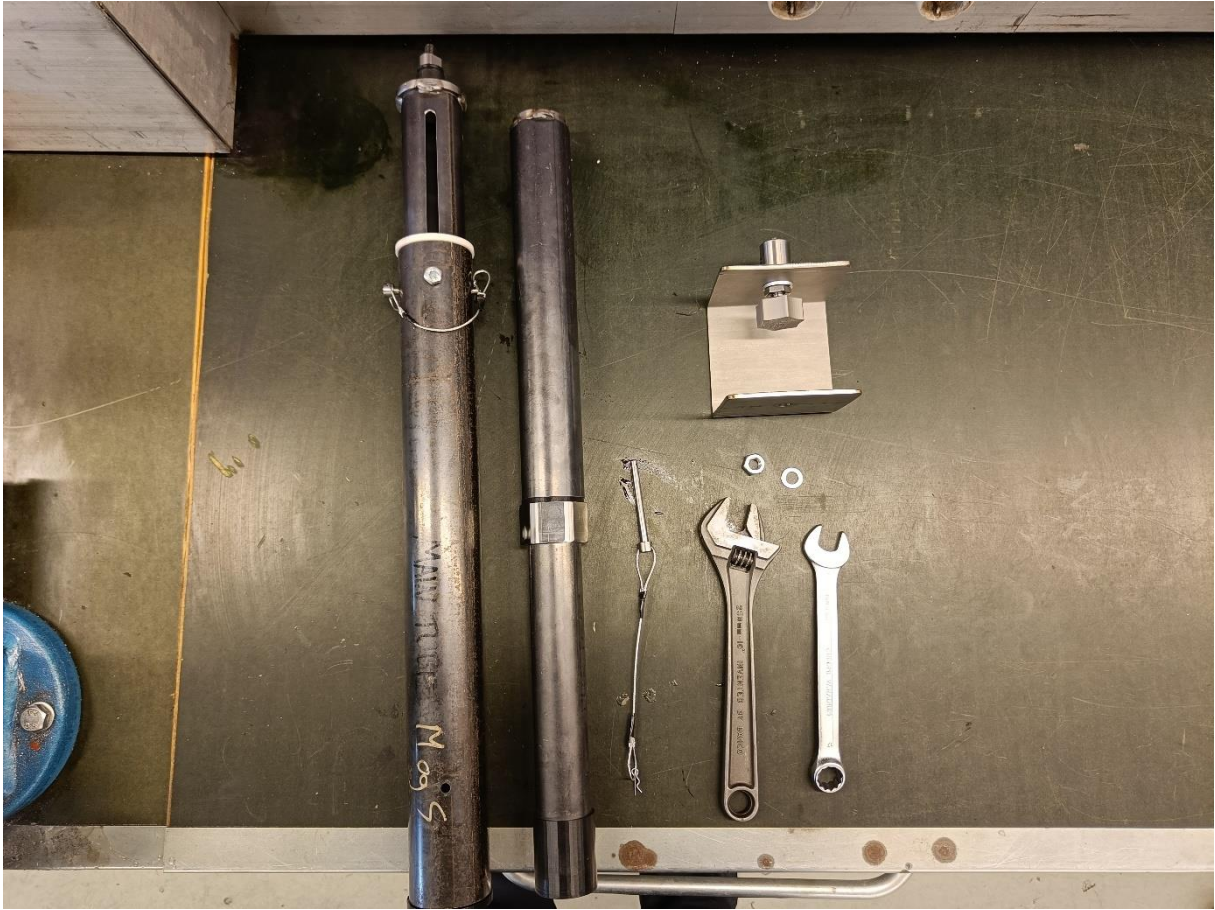

Figure 39, Subassemblies and necessary tools

7. ECONOMICS

For a product development project, it is essential to also have a look at the economical aspect to evaluate if the product has market potential or not. If the costs related to the manufacturing of the product will end up being too high, there is little point in releasing it to the market. For the product to be successful in both an economic and practical aspect, it must both satisfy a need and give value to the user, and at the same time be priced in a level that is satisfactory for the customer. If the price the customer is willing to pay is not enough to cover the costs related to manufacturing and make a profit, the product has little value to the developer.

For calculating the cost of the manufactured tool, the group have listed costs in different tables under, where the last table sums all costs to represent a final total cost. The standard components and 3D-printed parts in one section, and raw material plus CNC machining related costs in the other. The estimated prices for the 3D-printed are based on the amount of material spent per part. The prices used for the standard components are a combination of the actual prices for things the group purchased, and equivalent products to the ones used. The supplier (Norsk stål) had the same price pr kg for every dimension of the bar-material, S355j2+N, that was used in this project, meaning OD12 – OD65. Price pr kg: 48.07 kr. (Surnevik, personal communication, 2023 30. January). When placing an order at a machining shop like Aarbakke, multiple considerations make up the final price, for example:

- Number of parts
- Material of part
- Features and geometric appearance
- Dimensions and tolerances (example, Ra0.8 will cost more than Ra3.2)
- Rush job

For the sake of the Support Tool the machining costs listed in this project are standard costs, which means prices that reflect no extra cost, and none of the considerations above is priced in.

Table 20 shows the costs of all standard components and estimated prices for 3D-printed components.

Table 20, Cost of standard components and 3D-printed parts

Description	Quantity	Price per unit[nok]	Sum[nok]
Welded steel pipe 42,4x2,6mm [m]	0,3	83,33	43,15
Welded steel pipe 51,0x2,6mm [m]	0,677	108,56	73,50
Welded steel pipe 60,3x2,9mm [m]	0,5	143,84	71,92
Coil spring 340mm 1,83N/mm	1	418,19	418,19
Coil spring 10mm 0,71N/mm	1	56,36	56,36
SMC Floating Joint JA30-10-125	1	256,28	256,28
Square steel for C bracket	1	70	70,00
3D printed TPU foot	1	89	89,00
3D printed liner	2	160	320,00
Stainless Steel bearing ball Ø3,5mm	1	24	24,00
Stainless Steel Hex Nut, DIN 439B, M12	1	2,22	2,22
Stainless Steel Hex Bolt, M8 x 12mm	1	3,41	3,41
Stainless Steel Hex Socket Set M6 x 12mm	1	7,04	7,04
Stainless Steel Hex Socket Set M5 x 5mm	1	3,71	3,71
Steel Retaining Clip, 6.35mm Diameter	2	1,92	3,84
Steel wire 1,5mm [m]	0,3	6,49	1,95
Wire lock 2mm	4	7,58	30,32
SUM TOTAL			1474,88

Table 21 shows the cost of the bar material spent.

Table 21, Bar material cost

S355j2+N, OD12 - OD65	6kg * 48,07kr/kg
Material certificate fee	+ 150kr
Total	= 438,42kr

Table 22, Estimated machining time

Part	Setup time [min]	First run [min]	Auto [min]
Attachment bolt	30	120	18
Attachment body	60	180	25
C-bracket	30	30	5
Handle	30	45	8
D2 threaded cap conn.	45	60	7
Top tube	40	45	20
Main tube	30	30	15
Clevis pin	30	90	20 x2
Welded piston plug	60	80	10
Outer piston tube	45	80	15
Piston lock stopper	30	60	10
Piston lock	60	120	25
Inner piston tube	20	40	10
Tall nut M10x1,25	30	45	5
Total	540	1025	213

Table 22 shows the time spent for the different operations in machining.

Definition of the different posts in the table:

- *Setup time*, the time it takes to rigging tools and fixture.
- *First run*, the time it takes to machine the first part.
- *Auto*, the cycle time for machining each subsequent part after the first.

In table 23 the standard prices at Aarbakke are listed.

Table 23, Standard machining costs

Hour rate, CNC machine (depending on machine):	1600 – 2700 kr.
Hour rate, Machinist:	1300 kr.
Tooling costs, per part:	400 kr.

Calculating machining costs

- First Support Tool, 2000kr machine, 14 is number of individual parts:
 - $\text{hr} * (\text{machinist} + \text{machine}) + 400\text{kr} * 14 = \mathbf{91\ 675\text{kr}}$
- Every Support Tool after first, 2000kr machine, reduced tooling cost, 14 is number of individual parts:
 - $\text{hr} * (\text{machinist} + \text{machine}) + 200\text{kr} * 14 = \mathbf{14\ 515\text{kr}}$

Total cost

Table 24 shows the cost depending on the amount manufactured. Due to the extensive costs related to setup and first run, the cost of manufacturing a single tool is very high. The cost gradually decreases as the amount increases.

Table 24, Total cost of Support Tool

Cost from table 18	1474,88kr
Bar-material	+ 438,42kr
Machining	+ 91 675kr
Total, 1 Support Tool	= 93 588,3kr
	+ 9 * (14 515kr + 438,42kr + 1474,88kr)
Total, 10 Support Tool	= 241 443kr
Pr. Support tool	= 24 144,3kr

8. DISCUSSION

Through any product development process good time management is essential for the team's success. The group's approach to manage the time was to start early and to try to decide upon a concept as soon as possible. In doing this the group was able to order materials and standard components at an early stage and could stay ahead of schedule. However, ordering materials and components at an early stage, where all design decisions and calculations had yet to be executed, can mean that some important factors have been ignored. It's a tradeoff between gathering all necessary data and saving time. The implications of these decisions were that the group did not have sufficient knowledge about the quality of seam welded pipes, and that the first springs ordered for the piston were not of satisfactory stiffness for the final design.

In the early stages of the project, the group established a Gantt chart in order to manage the time efficiently and staying on schedule. Due to a lack of experience with product development projects, it was hard to produce accurate estimates for the duration of the different stages of the process. A lot of the activities were somewhat underestimated regarding duration. The modelling of the tool took longer than expected because of the constant changes and adjustments that were found necessary. As the group got to experience on multiple occasions, changing a feature on one part would often lead to needs for matching changes on the related parts. Manufacturing time was also underestimated. The group was fortunate to use the machinery of UIS workshop and Aarbakke, when these machines were not on full production. The group was aware of this in the planning of the project and managed to get all parts machined. It was challenging to juggle between running the different machines when they suddenly were available, and as of this reason the actual duration of manufacturing exceeded the estimates. The group see huge potential for cutting down machining time if the Support Tool ever where to go to full production, hence having prioritized machining.

The group has had a consistent and steady workflow through the whole duration of the project, and the focus has been more based on doing the next thing that comes naturally to the project than staying consistent to the Gantt chart.

The seam welded pipes were not as fit for the products as initially expected. Had they been perfect cylinders with the exact dimensions listed it would not be an issue, but due to lack of knowledge the group was unaware of how protrusive the internal weld would be. Another issue was that the pipes were not truly round and that the dimensions were not so precise. This led to different challenges in the manufacturing process, and some changes had to be made in order to make it work.

It became apparent that the initially estimated total weight of the support tool and Hytorc tool was a bit too low. The group had forgotten to take account for the weight of the socket and counterhold of the torque wrench, and therefore the precompression in the spring was not sufficient to keep the wrench

elevated without further compressing the piston. This emphasizes the importance of thorough planning, calculation and research in a product development process. Luckily the group was able to work around these challenges and still make a well-functioning product.

Another decision that could've been made differently if more research and calculations were done early on, is the choice of materials. The diameter of the pipes was decided to be of the current diameter due to the geometry of springs in the fitting lengths and stiffnesses. From a manufacturing perspective as of the types of machines the group could use and the ease of machining, the geometry of the pipes was in favor. Low cost and availability were also considered to be important factors for choosing what material the Support Tool would consist of. From the calculations one can see that the decision on having these pipes resulted in a body with an extreme safety factor for plastic deformation. The group and customer both agreed that an aluminum body, including design changes for cutting weight, would be worth investigating if the tool will be launched to the market.

The piston design could also be investigated in the future. One could do more research about existing pistons on the market and determine if one should buy a finished piston and apply it to the Support Tool. Another perspective for further development can be how to eliminate the issue of the piston lock stopper interfering with the weld seam when functioning. One could look at:

- Removing the weld seam
- Use seamless pipes
- Sliding PTFE bearing or PTFE cover over *Piston lock stopper*
- Change the design of the *Piston lock stopper*

In this project only a prototype of the tool was developed and no full-scale production of many tools. For that reason, there was no alteration of manufacturing procedures or investigations of cutting waste in a full production perspective. But still, the project's aim was also to find a solution for a design that was relatively easy to manufacture, which is a way of Lean thinking.

Rapid prototyping, minimum-manufacturing designs, utilizing standard inventory parts and unmanned manufacturing (if safe, let the machines run while doing other work), are examples of lean management the group focused on in this project.

If this tool is ever to go into full production, the Lean Manufacturing is the right way to make this Support tool profitable, and consequently some of the Lean considerations would be relevant to discuss:

- Define the value of the tool
- Finding the manufacturing company that can minimize wastes and maximize value the most, applying SMED
- Re-designing features of the Support-tool for both fitting the tool’s purpose and fit the manufacturing capabilities available

Figure 40 shows the planned Gantt chart in compared to actual time spent

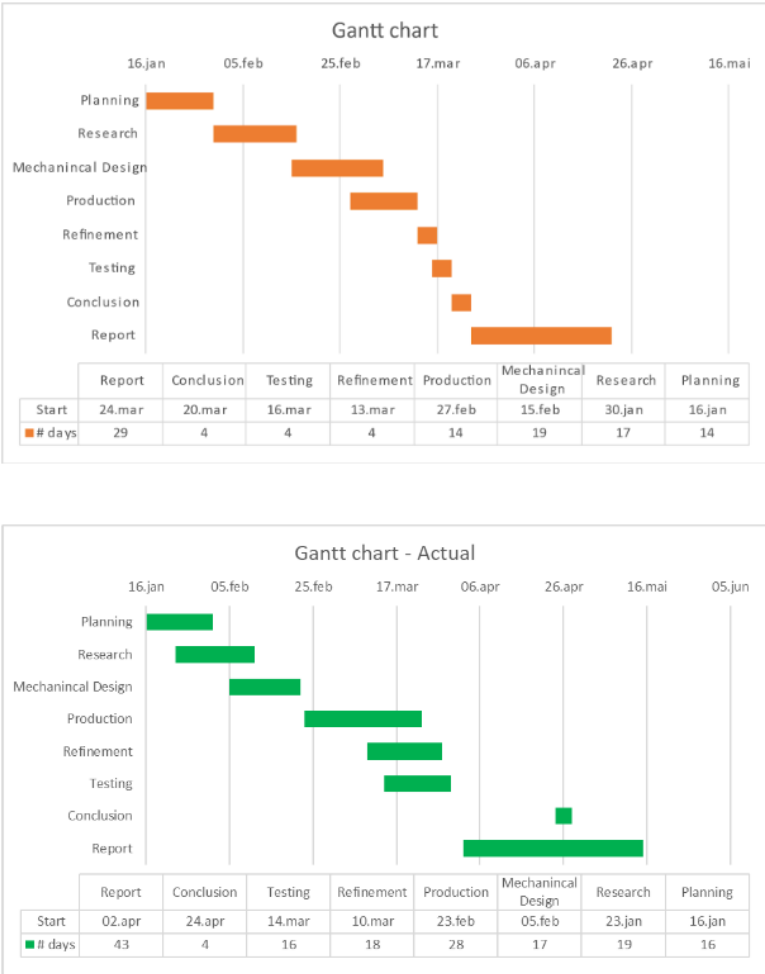

Figure 40, Gantt chat - estimated vs actual

9. CONCLUSION

The aim for this thesis was to develop and manufacture a functioning prototype of an ergonomic support tool for Hytorc torque wrenches in accordance with the product development process. The main objective was to have a well-functioning final product that has the potential for entering the market. By relying on the PDP and continuously discussing and advising each other, the group managed to design and manufacture a successful product. The ergonomic support tool works as planned, and through the tests executed in the workshop it really shows promise as a product that can be used to make work tasks safer and more effective.

Previous knowledge in some of the relevant fields made the group well equipped for executing the task. Having long experience with machining in addition to having worked in the wind turbines where the tool will be used, gave the group a lot of insight to the desired function of the tool as well as the means to manufacture it independently. Having personal practical knowledge of the task the tool is designed to improve, helped setting the right course for concept generation. Had it not been for the groups machining experience it would likely have led to not being able to finish the project. The group has put a lot of time and effort into the designing, dimensioning, manufacturing and improvements on the product. If the manufacturing could not be done as independently the improvements would most likely not have been finished in time.

An important lesson in this project was how the ideal digital models will not always match reality. When designing the tool, the pipes that made up the structure of the piston and body were of course perfectly round. When receiving the steel pipes that were ordered, the internal seam weld was quite a bit more protrusive than expected. The pipes were not perfectly round. These imperfections made the piston mechanism difficult to operate, and adjustments had to be made. The seam weld also interfered with the internal thread of the outer piston tube. Getting first-hand experience of such challenges is a good lesson, as well as a good way to challenge oneself to find creative solutions to solve unexpected problems that arise in the process.

The project has been both inspiring and challenging, and the group has learned a lot regarding the considerations that must be done when deciding on a design. Trying to think ahead and considering the implications of the different design choices that are considered is essential to be able to design and develop functioning products.

For the choice of materials, it is apparent that the construction steel pipes are over-dimensioned. As the decision to go for steel was made early on the mechanical calculations had yet to be made at that point. In retrospect the pipes could rather be in aluminum, and preferably in a seamless finish. Seamless pipes are however a lot more expensive, so a decision should be made whether the advantages would compensate for the additional costs.

10. BIBLIOGRAPHY

- ASM Inc. (n.d.). *AISI Type 316L Stainless Steel*. Retrieved 11.05 from: <https://asm.matweb.com/search/SpecificMaterial.asp?bassnum=mq316q>
- Bugge, M. D. (2021, December 27.) *hånd-arm-vibrasjonssyndrom – HAVS*. Store medisinske leksikon. Retrieved 7. May 2023 from https://sml.snl.no/h%C3%A5nd-arm-vibrasjonssyndrom_-_HAVS
- Chryssolouris, G., Panagiotopoulou, V.C. & Stavropoulos, P. (2022) *A critical review on the environmental impact of manufacturing: a holistic perspective*. Int J Adv Manuf Technol. <https://link.springer.com/article/10.1007/s00170-021-07980-w#citeas>
- Continental. (2015, June). Download-torque-settings-data. <https://blobs.continental-tires.com/www8/servlet/blob/1080706/71cfb5154e939befc74980e98145e9a3/download-torque-settings-data.pdf>
- Djuve, E. (n.d.). *Om oss*. Hytorc Norge AS. Retrieved 14 April 2023 from: <https://www.hytorc.no/om-oss/>
- EconClips. (2020, 2. December) *Lean manufacturing: A pursuit of perfection* [Video]. YouTube. https://www.youtube.com/watch?v=xkUjX_c32c8
- Eppinger, S. D. & Ulrich, K. T. (2012). *Product Design and Development* (Fifth Edition). McGraw-Hill.
- Lemu, H. G. (2021). *Dimensjonering av maskinelementer*. H. G. Lemu
- Grant, M. (2022, December 01). *Gantt Charting: Definition, Benefits, and How They're Used*. Investopedia. <https://www.investopedia.com/terms/g/gantt-chart.asp>
- Groover M. P (2021). *Fundamentals of Modern Manufacturing* (Seventh Edition). Wiley.
- Hartvigsen, H. Lorentsen, R. Michelsen, K. & Seljevoll, S. (2022). *Verkstedhåndboka* (Sixth Edition) Gyldendal.
- Hytorc. (n.d.). *About us*. Retrieved 14 April 2023 from: <https://hytorc.com/about-us>
- Karowski, W. & Marras, W. S. (1999). *The occupational ergonomics handbook*. CRC Press
- Lean Production. (n.d.). *SMED (Single- Minute Exchange of Die): Lean production*. Retrieved 15. April 2023 from: <https://www.leanproduction.com/smed/>
- MacLeod, D. (2006). *The ergonomics kit*. CRC Press
- Markforged Incorporated, *Markforged “Metal X system”*. Retrieved 5th May 2023. <https://markforged.com/3d-printers/metal-x>
- Norsk Stål. (n.d.). *Sveiste stålrør S235JRH*. Retrieved 20. May 2023 from: <https://www.norskstaal.no/produkter/kaldformede-profiler-og-roer/sveiste-staalroer-s235jrh>
- O’Brien, R. (1998). *An Overview of the Methodological Approach of Action Research*. Faculty of Information Studies, University of Toronto, p. 2-4, https://base.socioeco.org/docs/overview_of_action_research_methodology.pdf

- RS. (n.d.). *SMC Floating Joint JA30-10-125*. Retrieved 11. May 2023 from: <https://no.rs-online.com/web/p/pneumatic-cylinder-actuator-accessories/2097955>
- Sodemann Fjær. (n.d.). *Sodemann Fjær*. Retrieved 11. May 2023 from: <https://www.fjaer.net/>
- Steelconstruction. (n.d.). *Steel material properties*. Retrieved 11. May 2023 from: https://www.steelconstruction.info/Steel_material_properties#Yield_strength
- Steelnumber. (n.d.). *S235JRH*. Retrieved 11. May 2023 from: http://www.steelnumber.com/en/steel_composition_eu.php?name_id=645
- Trout, J. (n.d.). *Lean Manufacturing Explained*. Reliableplant. Retrieved 15. April 2023 from: <https://www.reliableplant.com/Read/30267/lean-manufacturing-techniques>
- Wade, O. (n.d.). *How much torque can a human use by hand?*. Remodelormove. Retrieved 12. May 20223 from: <https://www remodelormove.com/how-much-torque-can-a-human-use-by-hand/>
- Yin, R. K. (2018). *Case Study Research and Applications: Design and Methods* (Sixth edition). Sage.

Appendix A - Videos

Table A-1, Video links

Description	URL
Support tool demonstration	https://vimeo.com/826654158
Support tool assembly	https://vimeo.com/826660469
Piston concept animation	https://vimeo.com/824318029
Floating joint explanation	https://vimeo.com/826663427
Bolt retainer mechanism	https://vimeo.com/826662487

Appendix B – Technical drawings, Piston

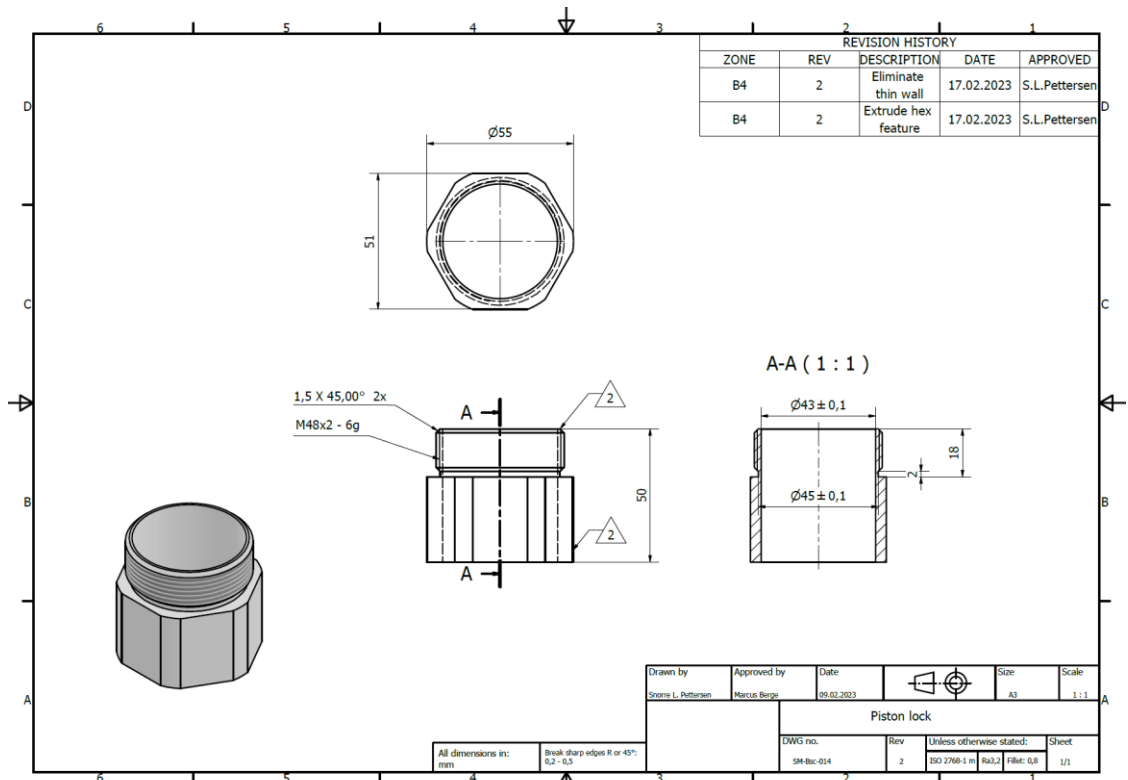

Figure B-1, Piston lock

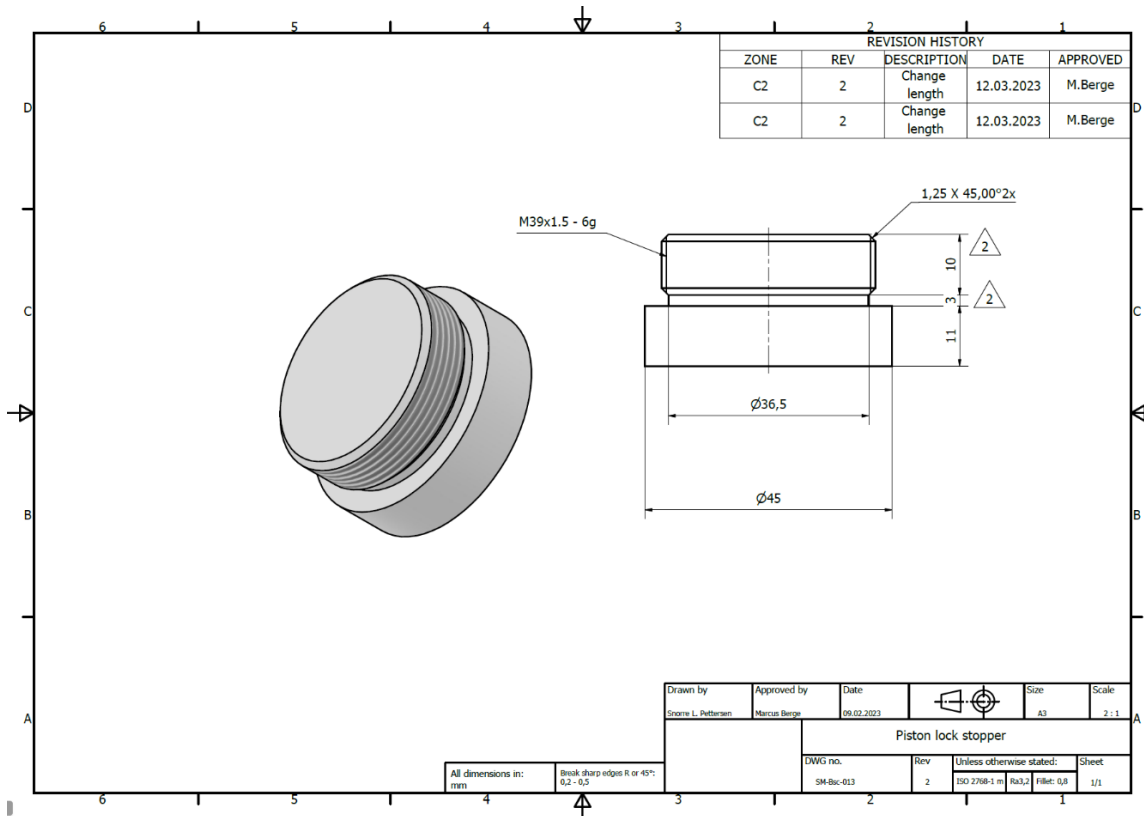

Figure B-2, Piston lock stopper

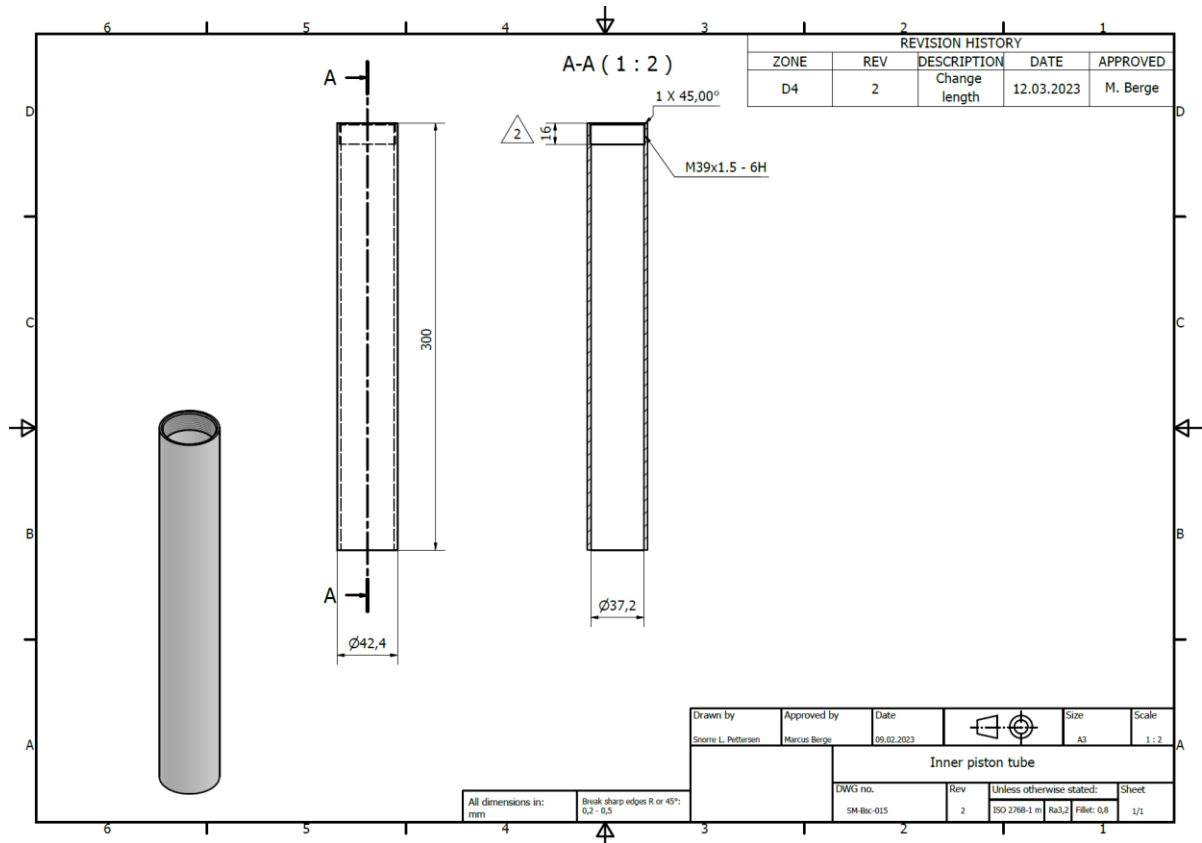

Figure B-3, Inner piston tube

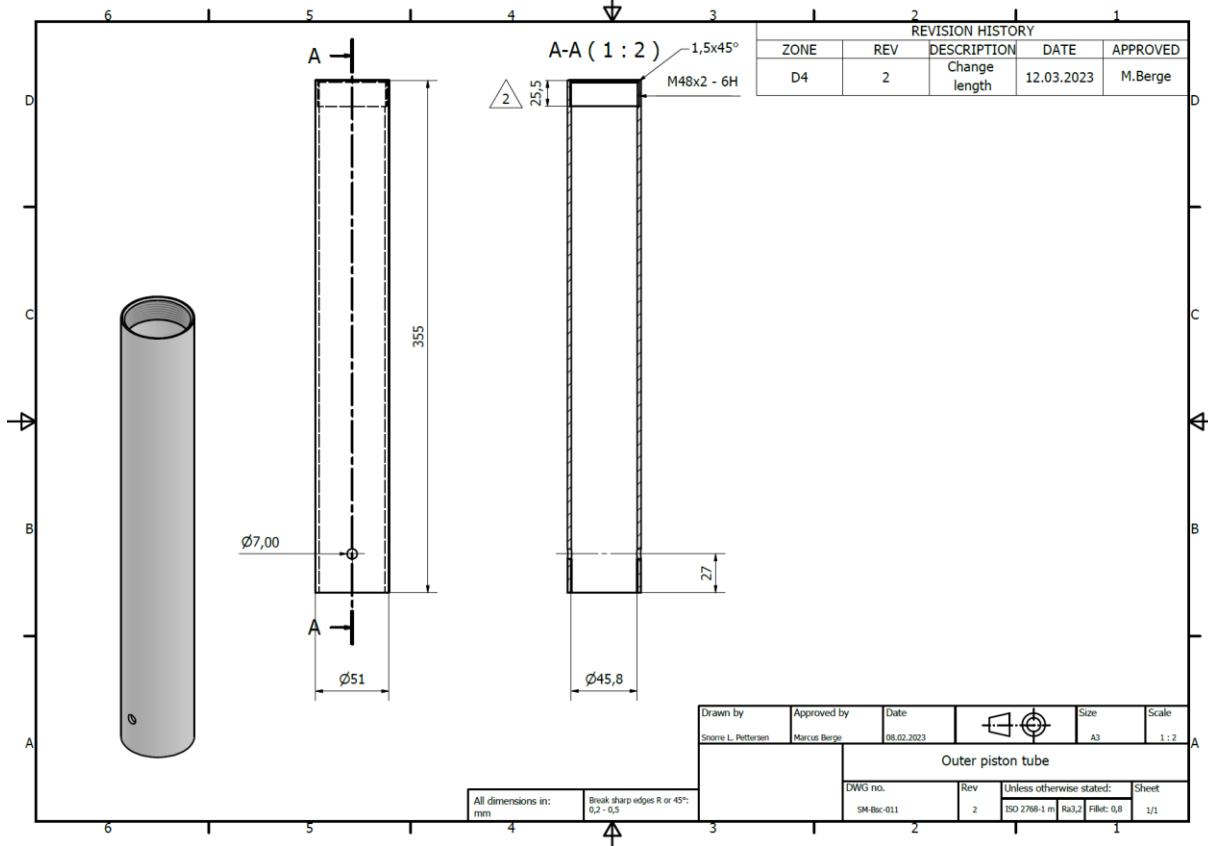

Figure B-4, Outer piston tube

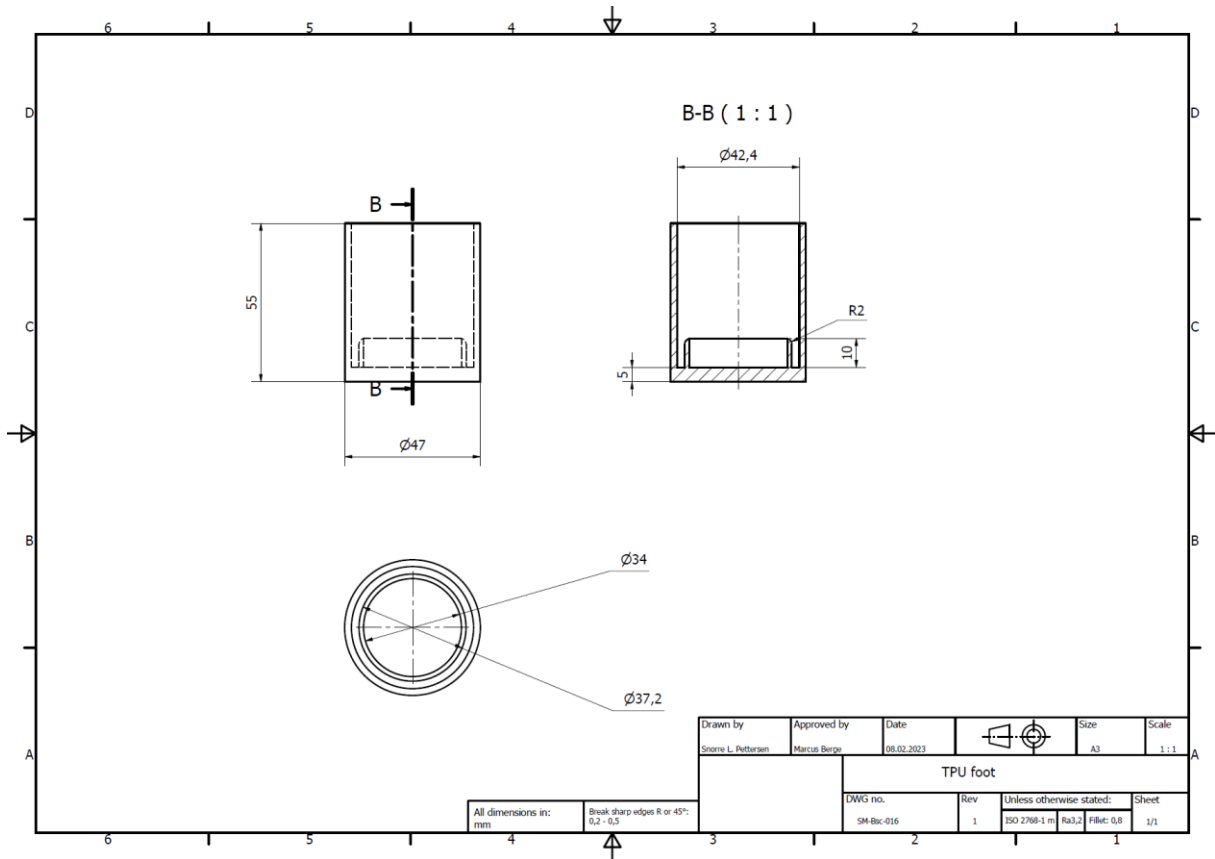

Figure B-5, TPU foot

Appendix C – Technical drawings, Attachment bracket

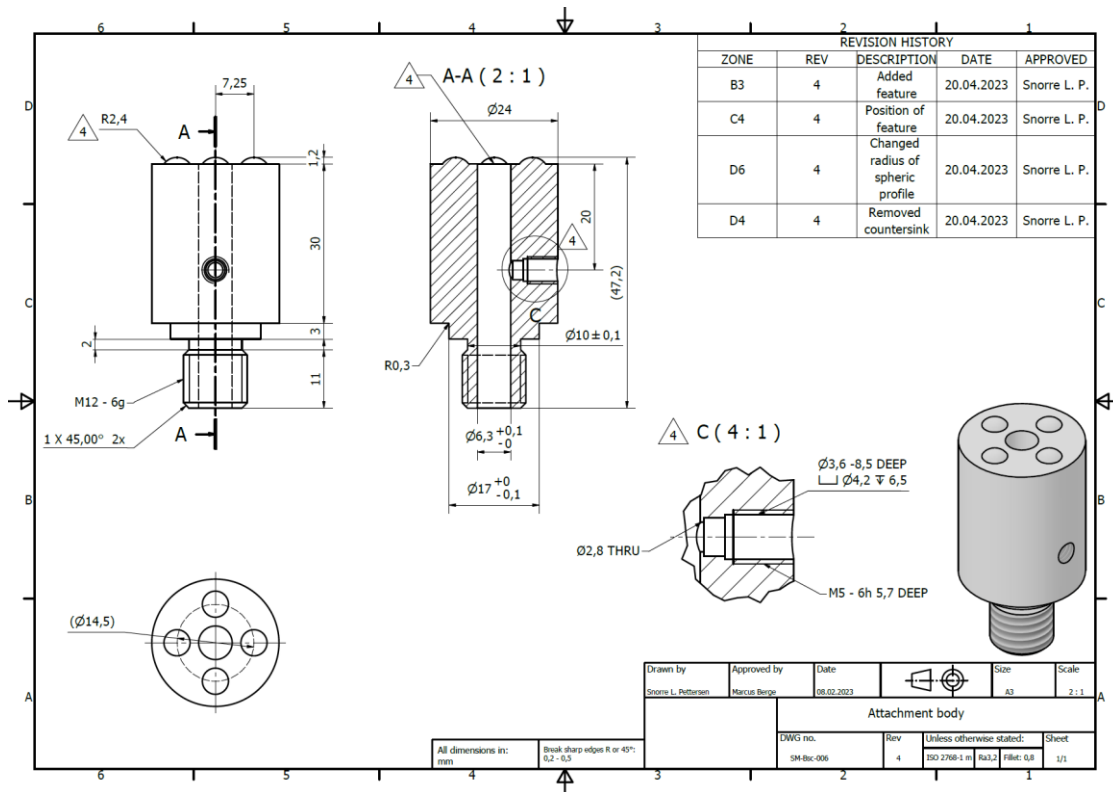

Figure C-1, Attachment body

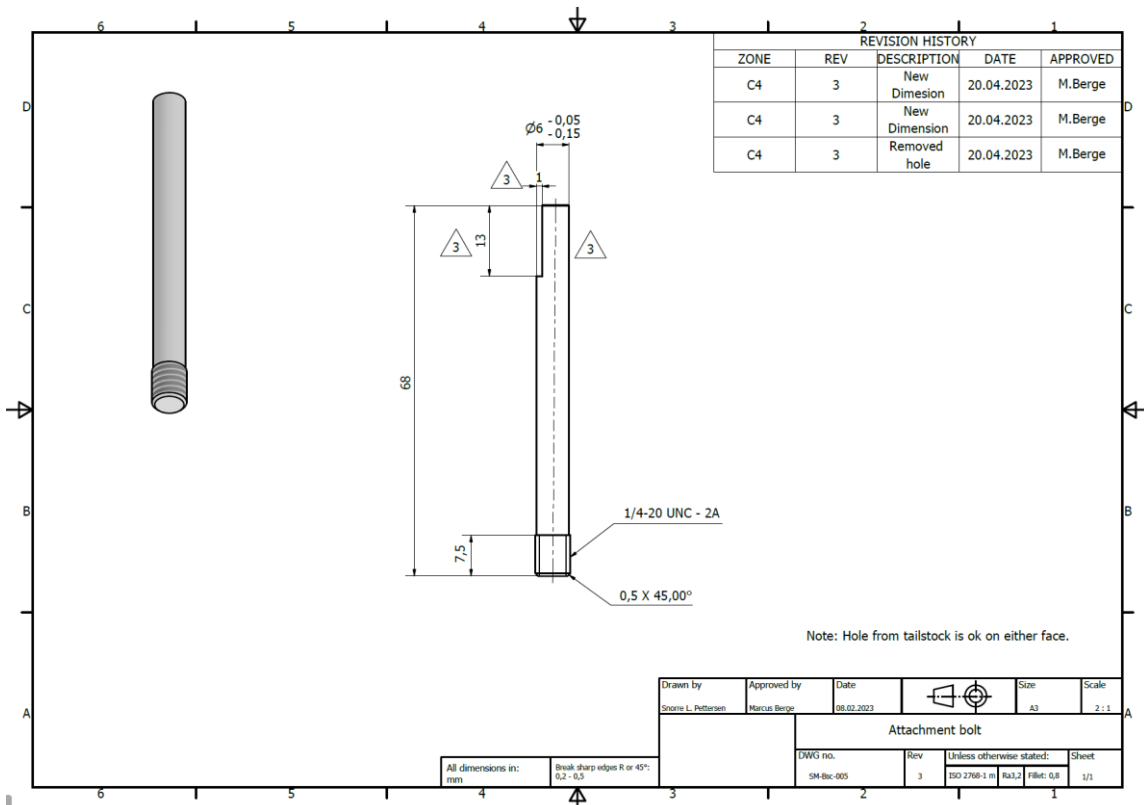

Figure C-2, Attachment bolt

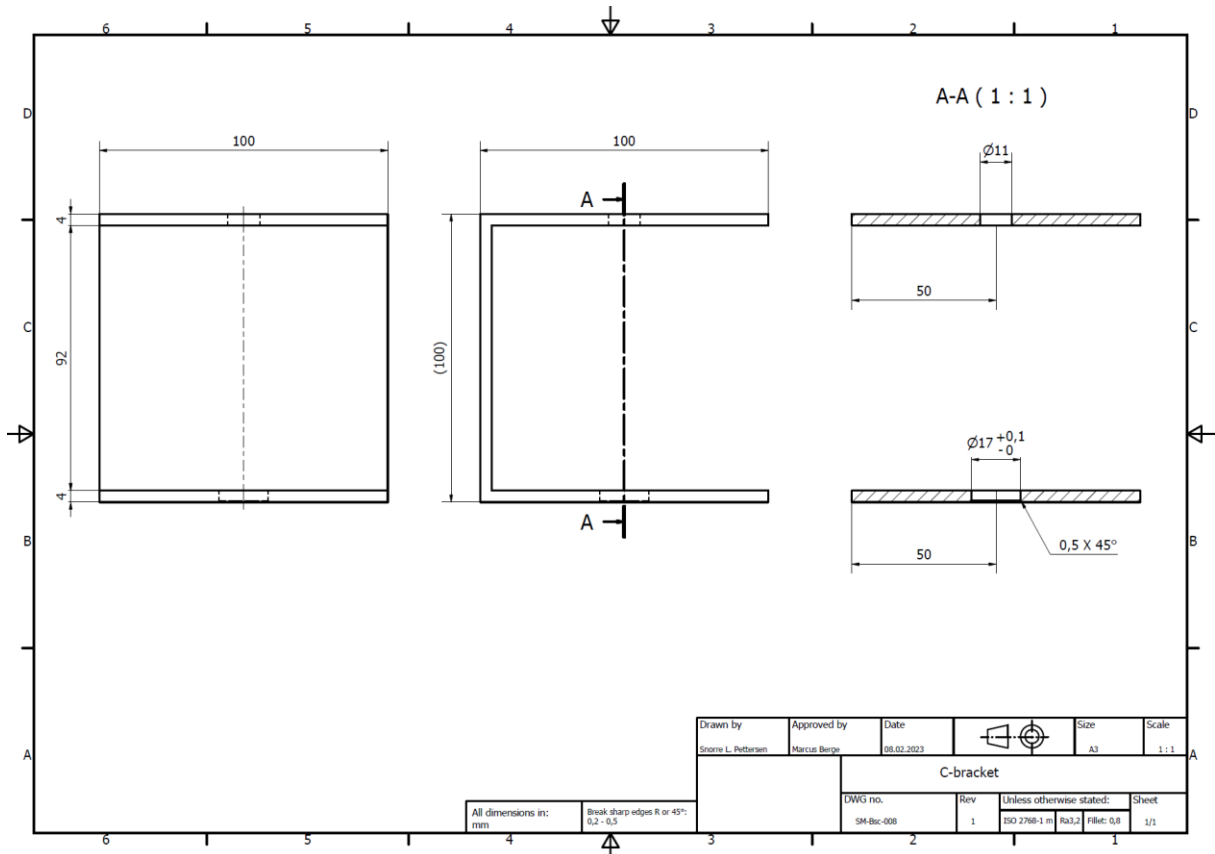

Figure C-3, C-bracket

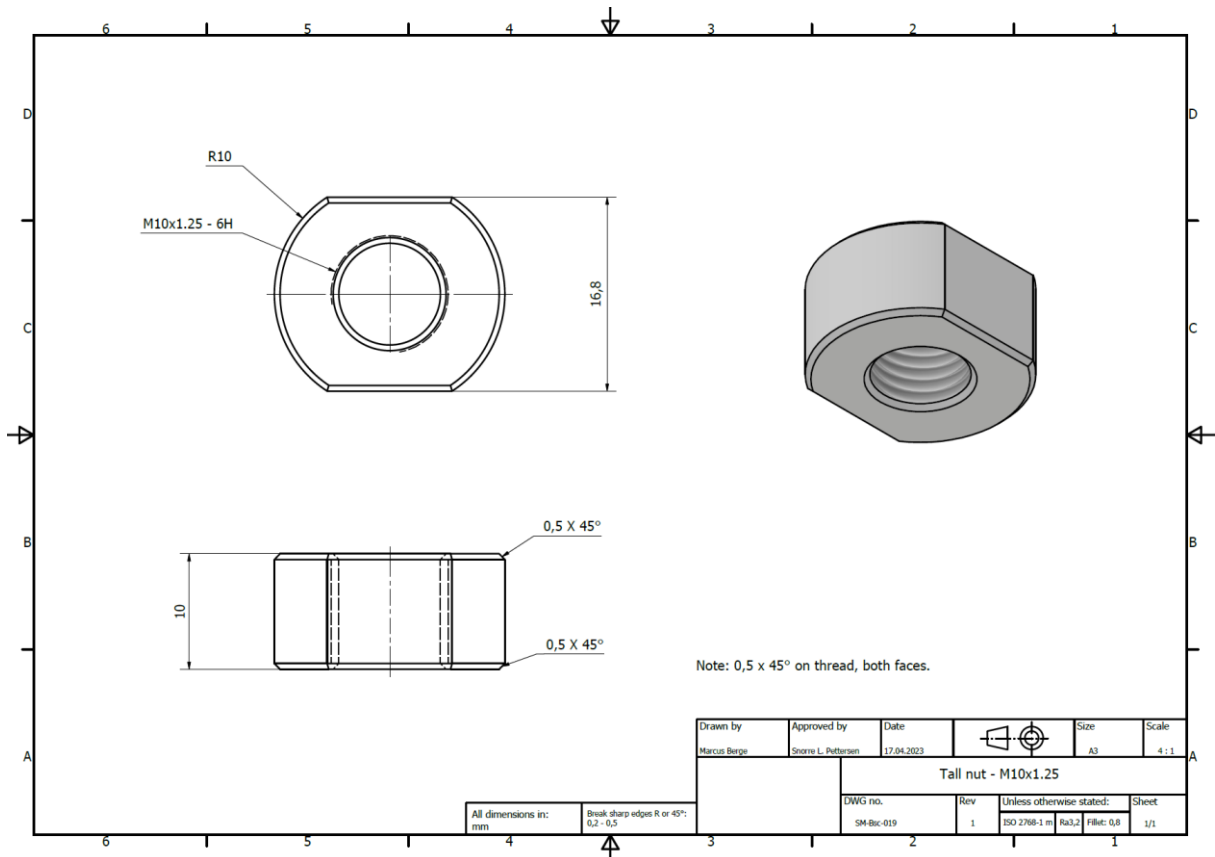

Figure C-4, Tall nut

Appendix D – Technical drawings, Main body

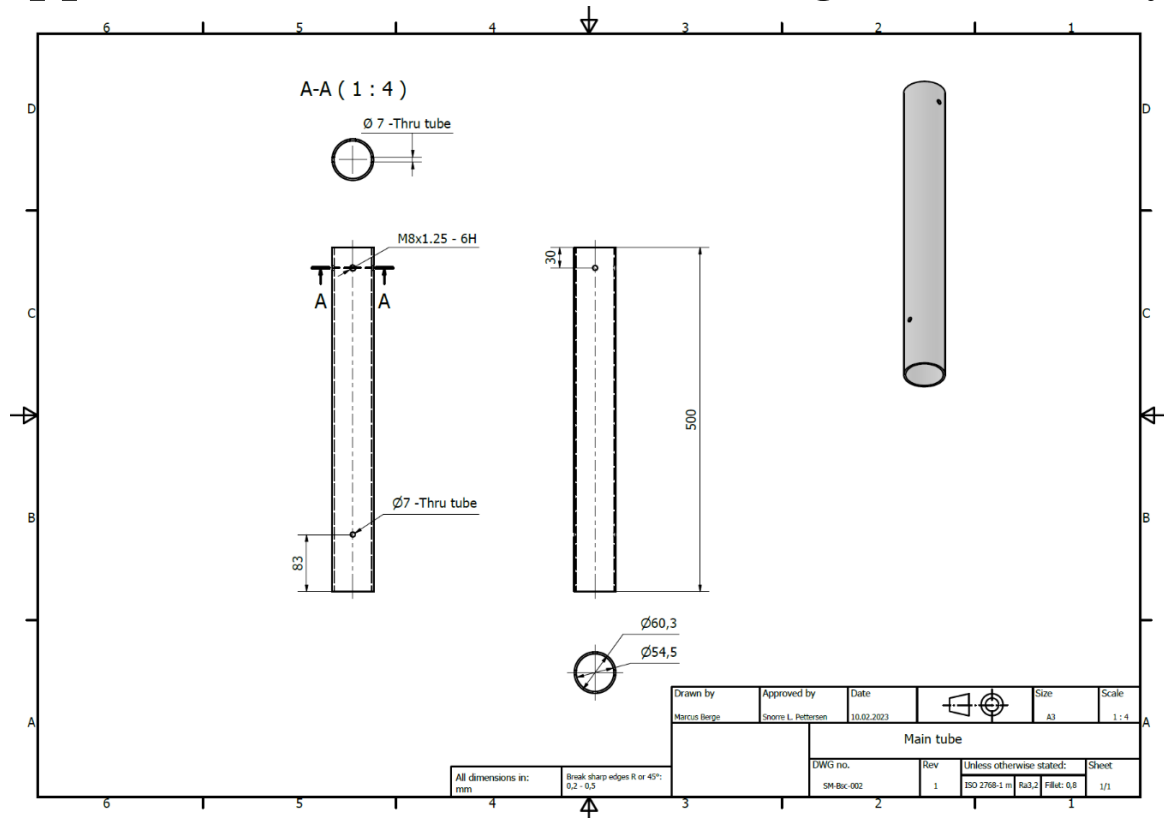

Figure D-1, Main tube

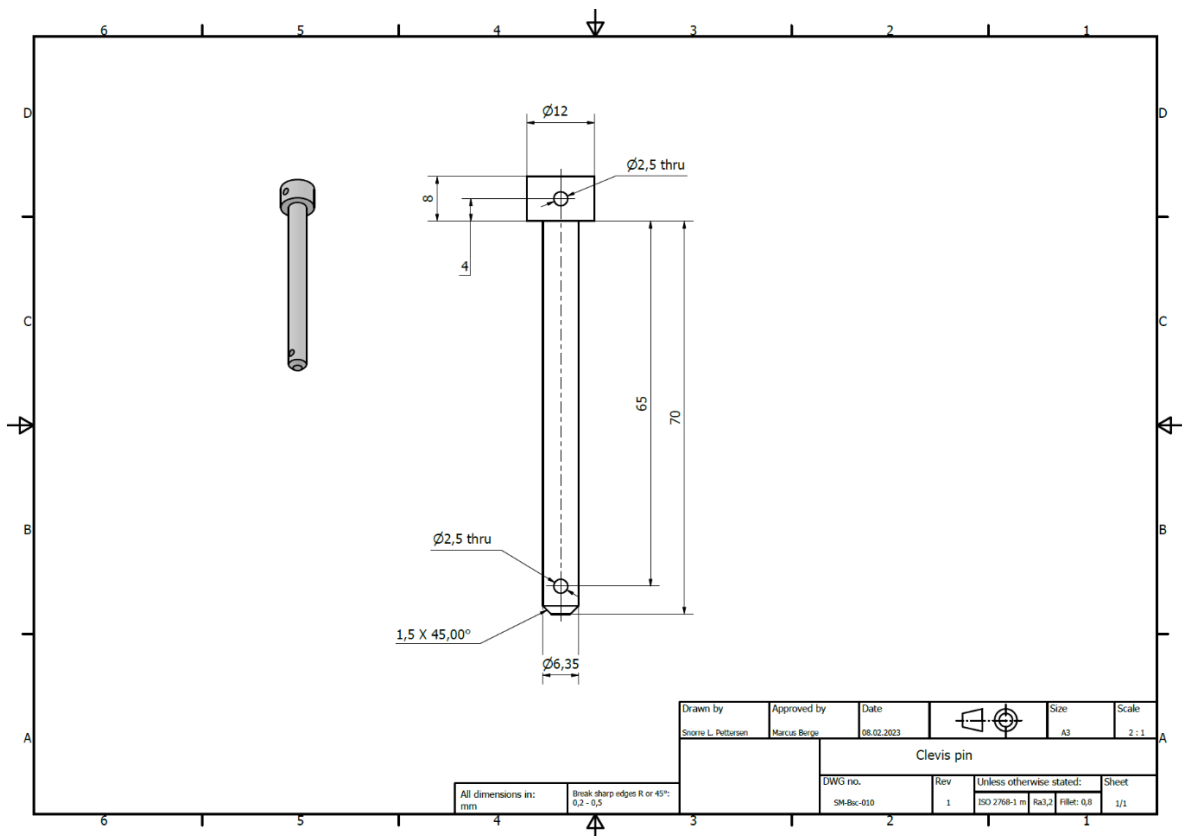

Figure D-2, Clevis pin

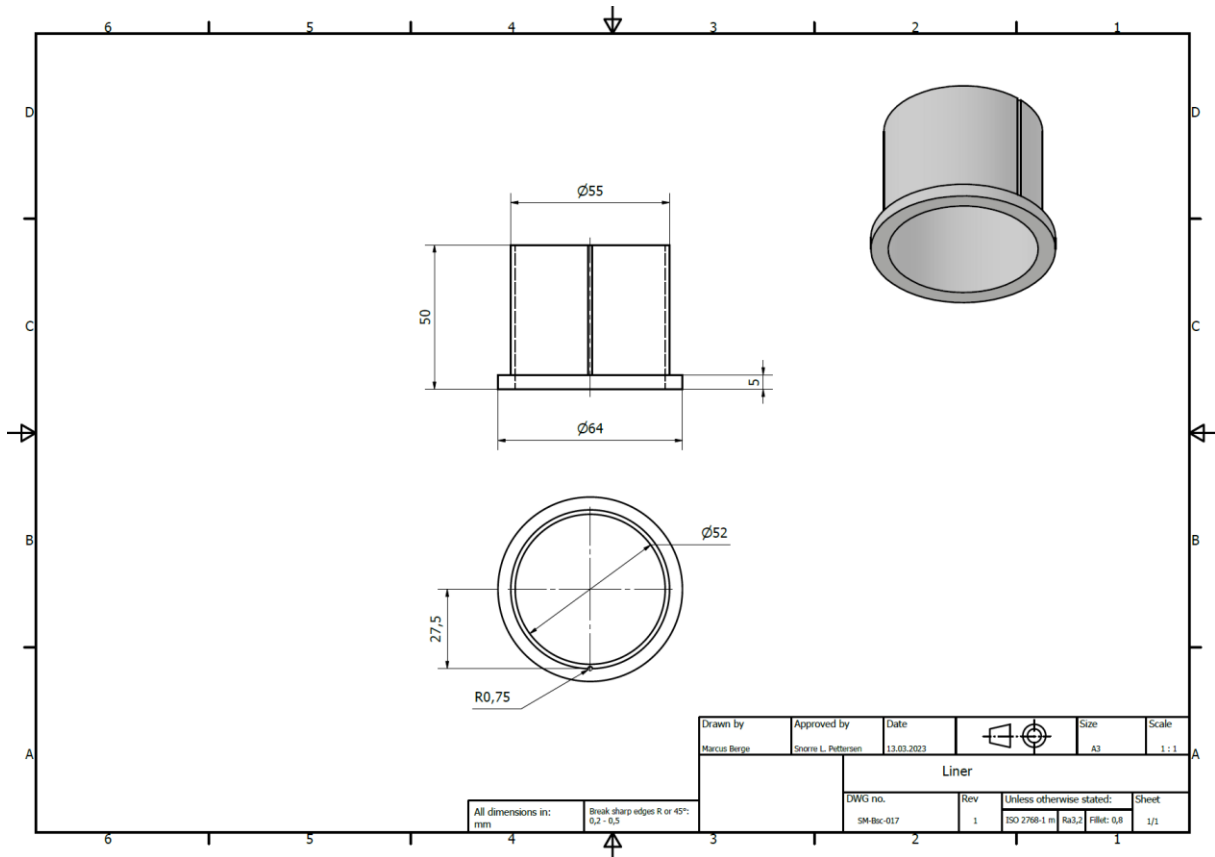

Figure D-3, Liner

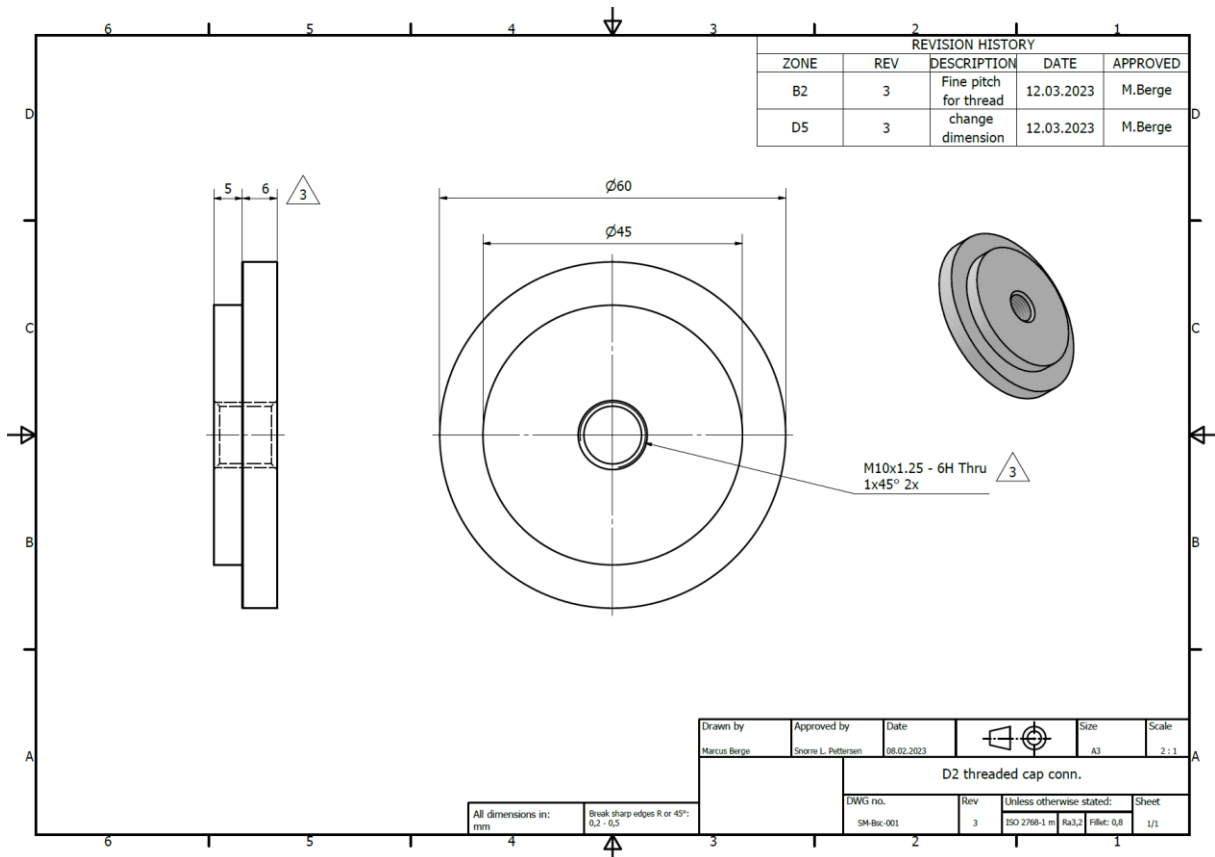

Figure D-4, Threaded cap connection

Appendix E – Assembly drawings

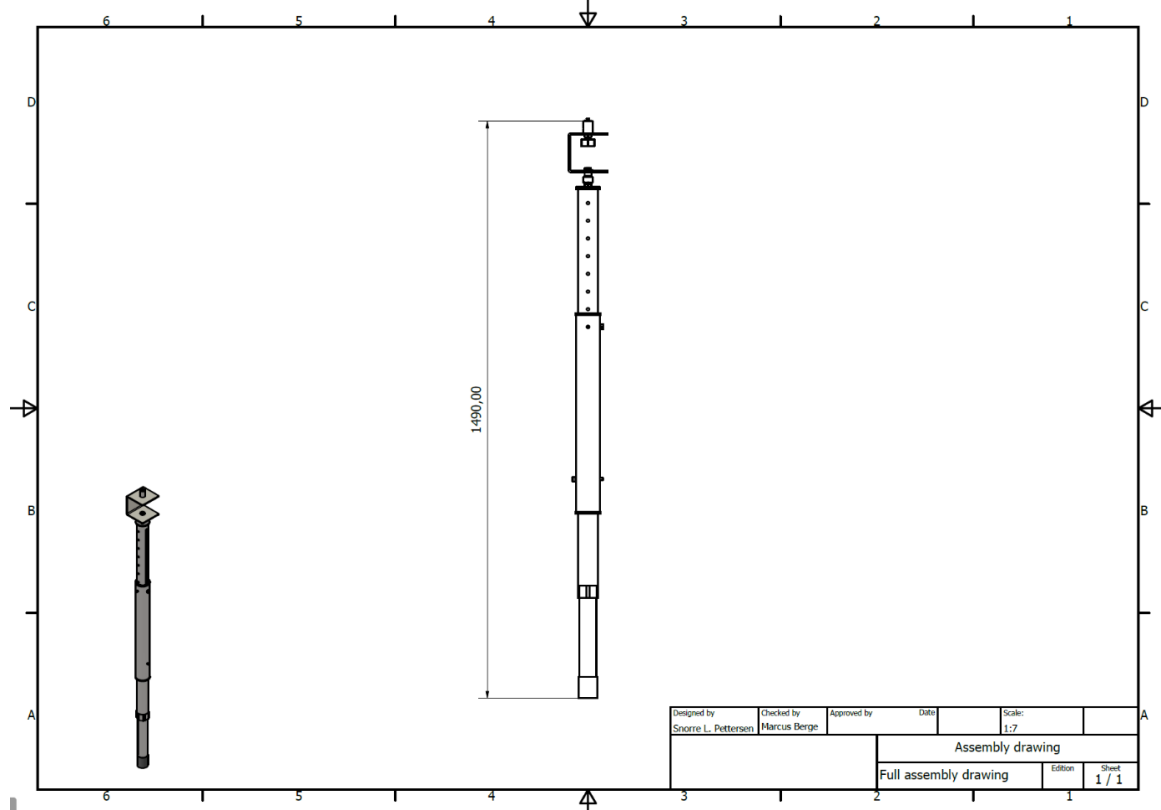

Figure E-1, Assembly drawing

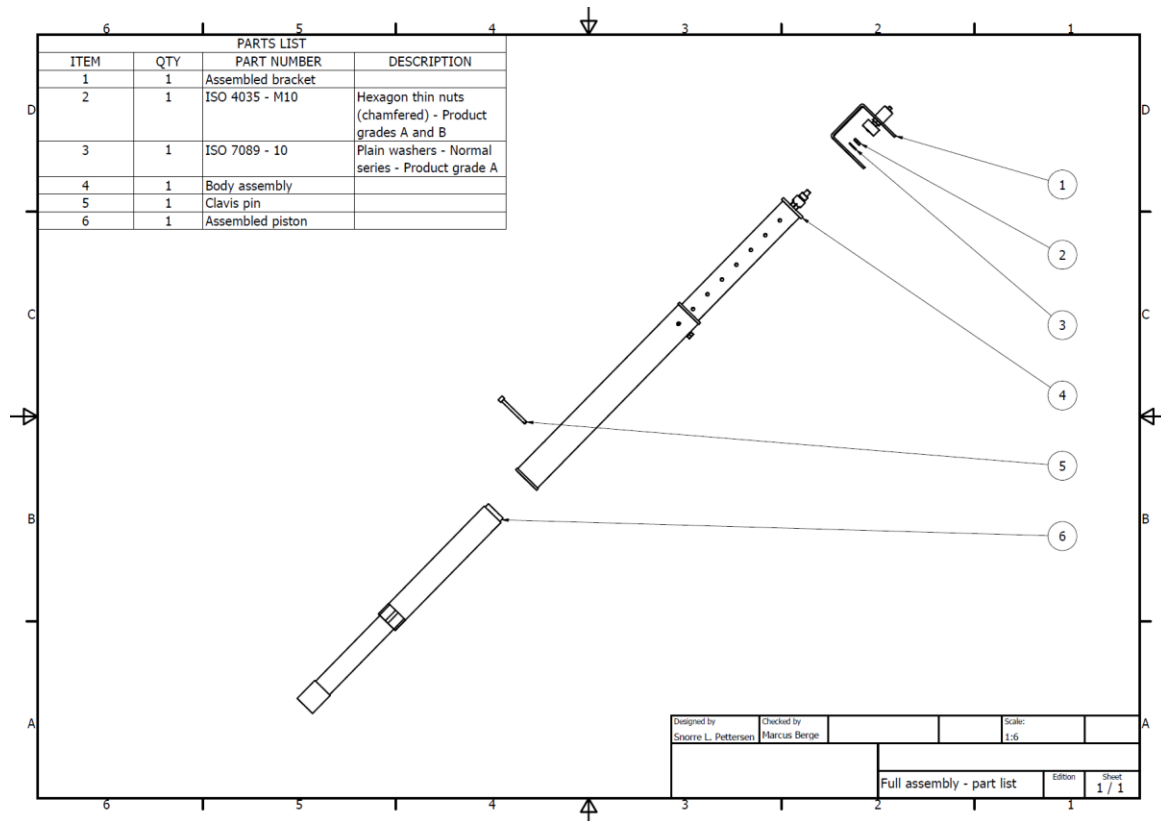

Figure E-2, Full assembly - part list

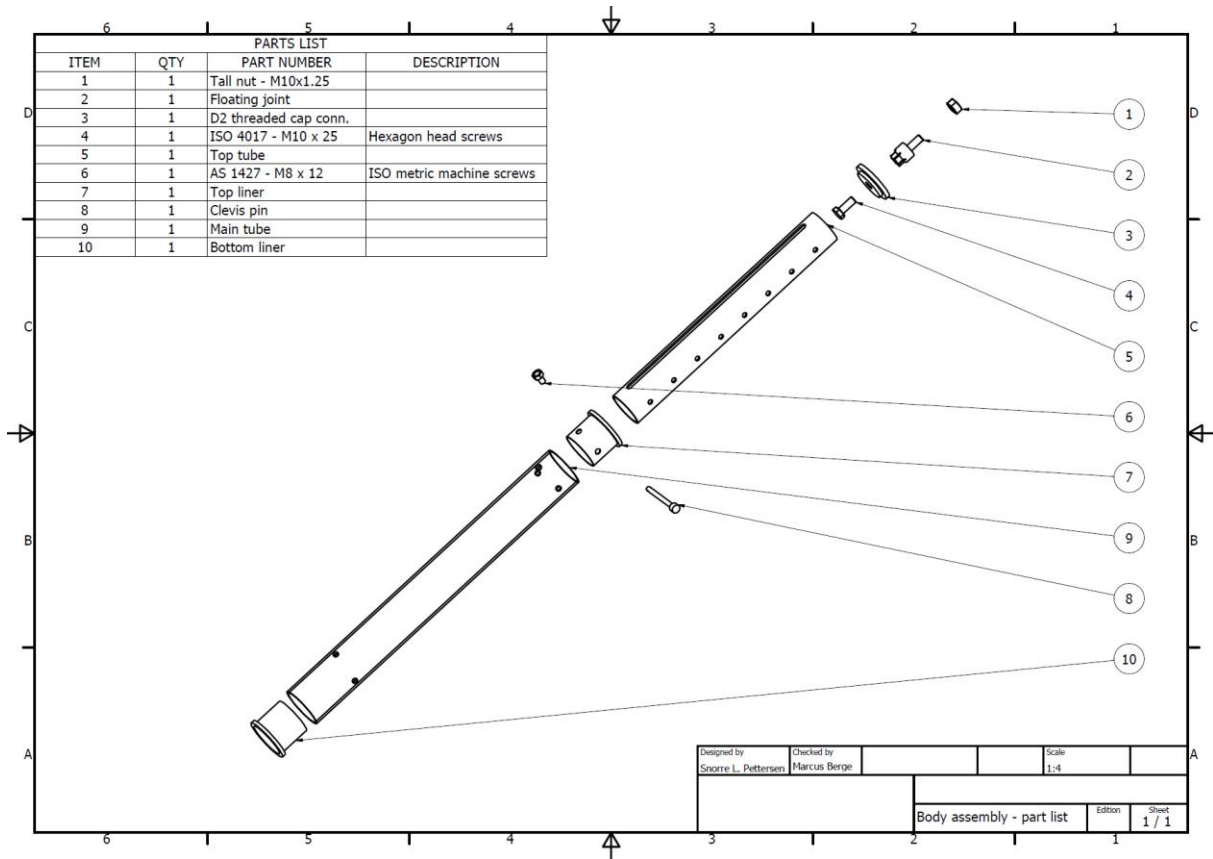

Figure E-3, Body assembly - part list

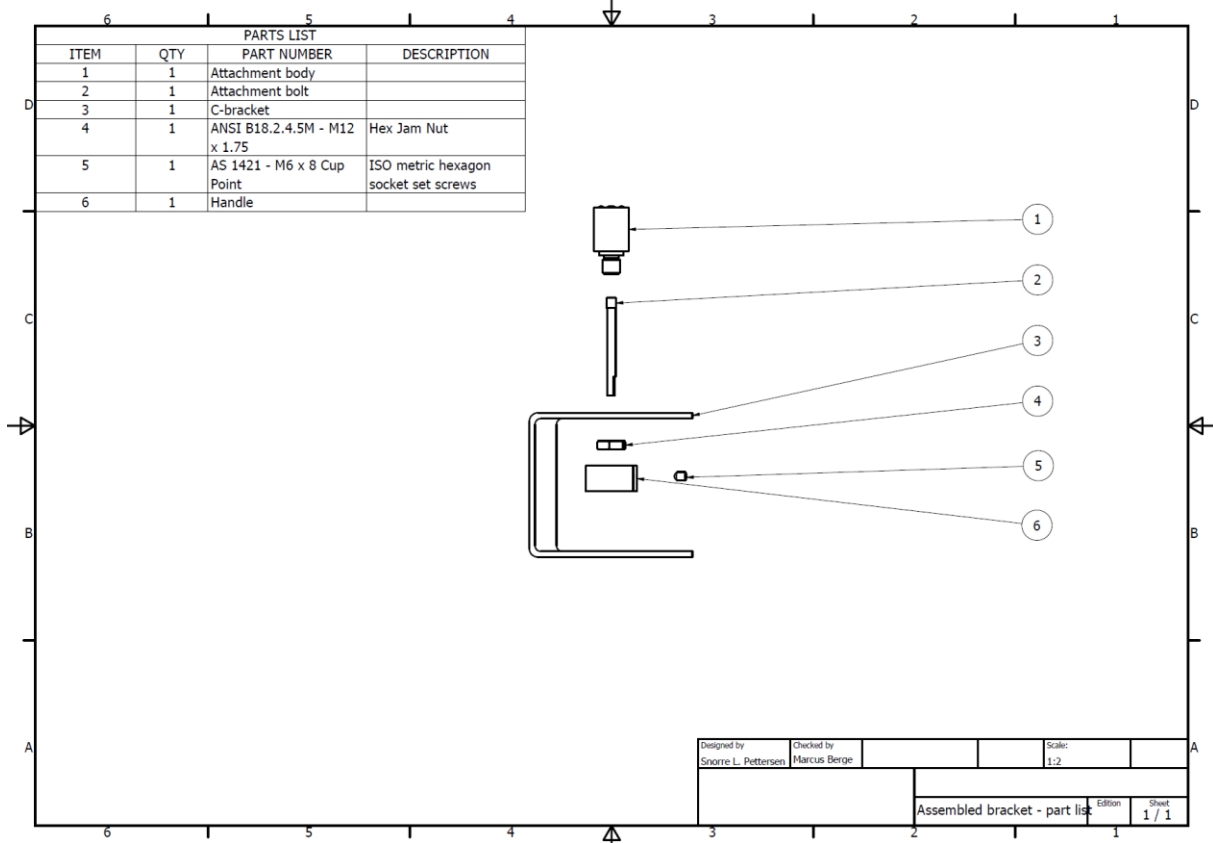

Figure E-4, Attachment body assembly - part list

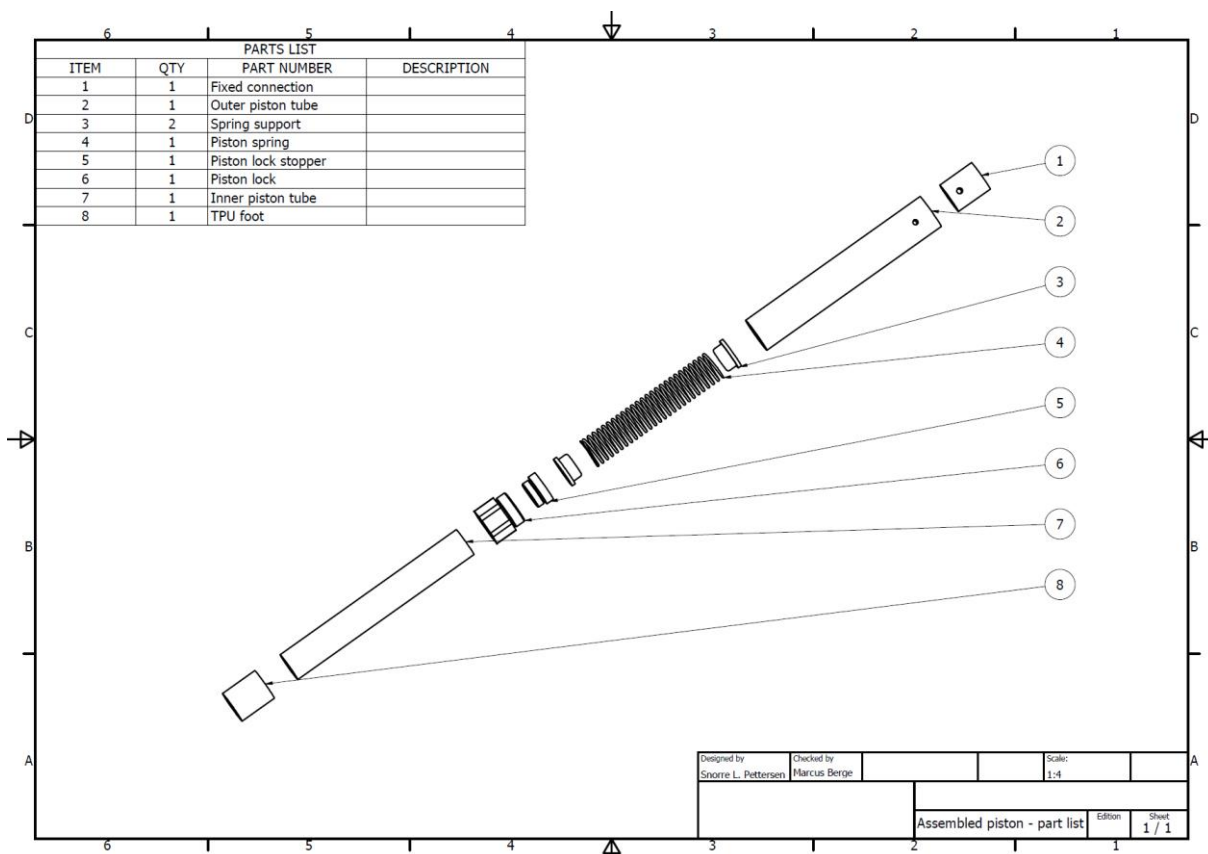

Figure E-5, Piston assembly - part list

Appendix G, Mathcad

Material Properties

$$E := 200 \text{ GPa} \quad \rho := 7850 \frac{\text{kg}}{\text{m}^3}$$

$$\sigma_{\text{yieldS235}} := 235 \text{ MPa} \quad \sigma_{\text{yieldS355}} := 355 \text{ MPa} \quad \sigma_{\text{yield316L}} := 205 \text{ MPa}$$

Cross sections

$$\begin{aligned} D_{o1} &:= 42.4 \text{ mm} & D_{i1} &:= 37.2 \text{ mm} & t_1 &:= \frac{(D_{o1} - D_{i1})}{2} = 2.6 \text{ mm} \\ D_{o2} &:= 51.0 \text{ mm} & D_{i2} &:= 45.8 \text{ mm} & t_2 &:= \frac{(D_{o2} - D_{i2})}{2} = 2.6 \text{ mm} \\ D_{o3} &:= 60.3 \text{ mm} & D_{i3} &:= 54.5 \text{ mm} & t_3 &:= \frac{(D_{o3} - D_{i3})}{2} = 2.9 \text{ mm} \end{aligned}$$

Cross section area function

$$\text{area}(OD, ID) := \pi \cdot \left(\left(\frac{OD}{2} \right)^2 - \left(\frac{ID}{2} \right)^2 \right)$$

Second area moment function

$$\text{areamom}(OD, ID) := \pi \cdot \frac{OD^4 - ID^4}{64}$$

$$A_1 := \text{area}(D_{o1}, D_{i1}) = 325.092 \text{ mm}^2$$

$$I_1 := \text{areamom}(D_{o1}, D_{i1}) = (6.464 \cdot 10^4) \text{ mm}^4$$

$$A_2 := \text{area}(D_{o2}, D_{i2}) = 395.338 \text{ mm}^2$$

$$I_2 := \text{areamom}(D_{o2}, D_{i2}) = (1.161 \cdot 10^5) \text{ mm}^4$$

$$A_3 := \text{area}(D_{o3}, D_{i3}) = 522.95 \text{ mm}^2$$

$$I_3 := \text{areamom}(D_{o3}, D_{i3}) = (2.159 \cdot 10^5) \text{ mm}^4$$

Mass of ICE 5:

$$m_{\text{ice}} := 10.92 \text{ kg}$$

Mass of the typically used socket:

$$m_{\text{socket}} := 2.5 \text{ kg}$$

Total tool weight:

$$W_{\text{wrench}} := g \cdot (m_{\text{ice}} + m_{\text{socket}}) = 131.605 \text{ N}$$

Safety factor function

$$\text{safac}(\text{yield}, \text{stress}) := \frac{\text{yield}}{\text{stress}}$$

Initial spring calculations

Initially assumed total weight of tool and ICE-5:

$$W_i := 16.5 \text{ kg} \cdot g = 161.81 \text{ N}$$

Spring data

Unloaded length: $L_{01} := 405 \text{ mm}$

Fully compressed length: $L_{n1} := 84.5 \text{ mm}$

Stiffness factor: $k_1 := 0.9 \frac{\text{N}}{\text{mm}}$

Max force: $F_{max1} := k_1 \cdot (L_{01} - L_{n1}) = 288.45 \text{ N}$

Solve for needed displacement to reach preload equal to total weight of tool

Needed displacement:

$$x_1 := \frac{W_i}{k_1} = 179.789 \text{ mm}$$

Piston length:

$$L_1 := L_{01} - x_1 = 225.211 \text{ mm}$$

Euler Buckling

Formula for critical buckling load:

$$buckl(E, I, K, L) := \frac{\pi^2 \cdot E \cdot I}{(K \cdot L)^2}$$

Effective length factor for Euler case 3:

$$K := 0.7$$

Vertical load: $F_{vert} := 300 \text{ N}$

Length: $L := 1500 \text{ mm}$

Calculated buckling load for smallest cross section:

$$F_E := buckl(E, I_1, K, L) = 115.74 \text{ kN}$$

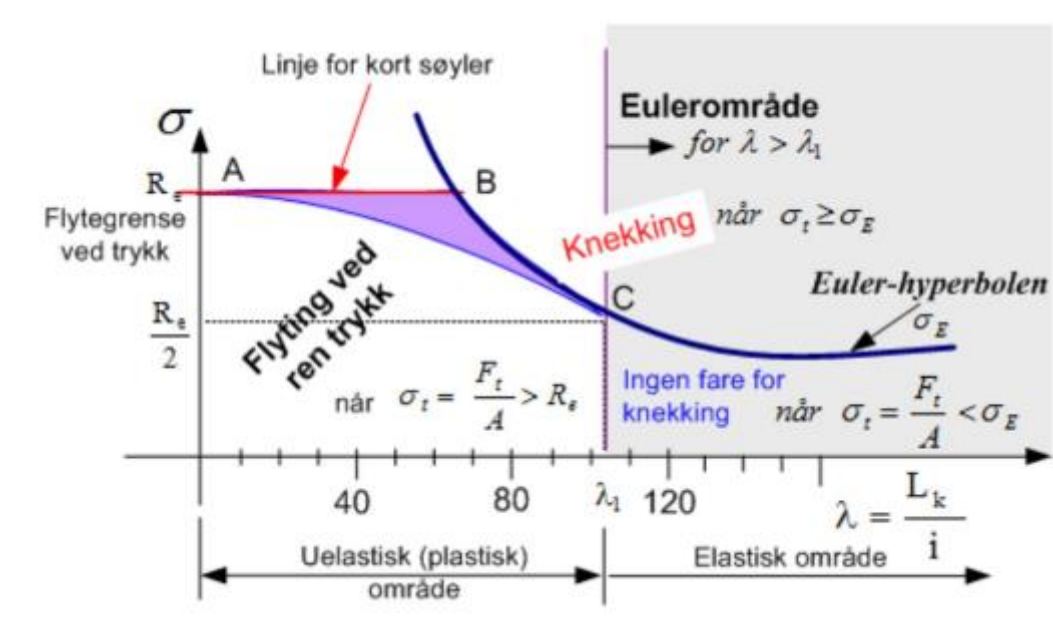

Radius of gyration:

$$i := \sqrt{\frac{I_1}{A_1}} = 14.101 \text{ mm}$$

Slenderness:

$$\lambda := \frac{L \cdot K}{i} = 74.461$$

Critical slenderness

$$\lambda_1 := \sqrt{\frac{2 \cdot \pi^2 \cdot E}{\sigma_{yieldS355}}} = 105.455$$

$\lambda < \lambda_1 \Rightarrow$ Not in the Euler area

$$SF_{buckling} := safac(F_E, F_{vert}) = 385.8$$

Stress calculations in C bracket

Dimensions:

$$l := 100 \text{ mm}$$

$$w := 100 \text{ mm}$$

$$h := 100 \text{ mm}$$

$$t := 4 \text{ mm}$$

Load:

$$F_z := 300 \text{ N}$$

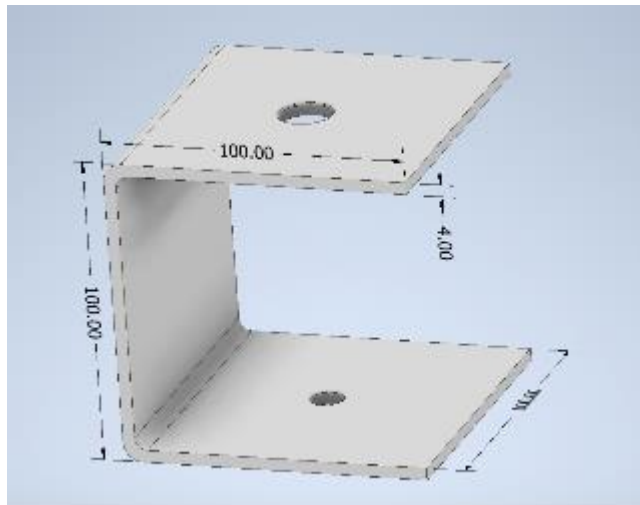

$$M_b := F_z \cdot \frac{l}{2} = 15 \text{ N}\cdot\text{m}$$

$$I := \frac{w \cdot t^3}{12} = 533.333 \text{ mm}^4$$

$$A_{cs} := w \cdot t = 400 \text{ mm}^2$$

Stress due to bending:

$$\sigma_b := \frac{M_b \cdot \frac{t}{2}}{I} = 56.25 \text{ MPa}$$

Stress due to shear force:
(only present on top side)

$$\tau := \frac{F_z}{A_{cs}} = 0.75 \text{ MPa}$$

Normal stress:

(only present on the side wall)

$$\sigma_n := \frac{F_z}{A_{cs}} = 0.75 \text{ MPa}$$

Equivalent stress:

Maximum equivalent stress will occur when bending moment is at max and when shear stress is still present. This is because the shear and normal stress are equal, and the $\sqrt{3}$ multiplier for shear stress in the von mises stress formula.

$$\sigma_e := \sqrt{\sigma_b^2 + 3 \cdot \tau^2} = 56.265 \text{ MPa}$$

safety factor:

$$sf := \text{safac}(\sigma_{\text{yield}316L}, \sigma_e) = 3.643$$

Weight reduction

Weight reduction function

$$wr(s, A, \rho) := s \cdot A \cdot \rho \cdot g$$

Top tube weight reduction:

Length of cut:

$$s_{top} := 70 \text{ mm}$$

Weight reduction:

$$\delta W_{top} := wr(s_{top}, A_2, \rho) = 2.13 \text{ N}$$

Mass reduction:

$$\delta m_{top} := \frac{\delta W_{top}}{g} = 217.238 \text{ gm}$$

Welded piston plug weight reduction:

Bore depth:

$$s_{bore} := 54 \text{ mm}$$

Bore diameter:

$$d_{bore} := 35 \text{ mm}$$

Bore area:

$$A_{bore} := \pi \cdot \left(\frac{d_{bore}}{2} \right)^2 = 962.113 \text{ mm}^2$$

Weight reduction:

$$\delta W_{plug} := wr(s_{bore}, A_{bore}, \rho) = 4 \text{ N}$$

Mass reduction:

$$\delta m_{plug} := \frac{\delta W_{plug}}{g} = 407.84 \text{ gm}$$

Total weight reduction:

$$\delta W_{tot} := \delta W_{top} + \delta W_{plug} = 6.13 \text{ N}$$

Total mass reduction:

$$\delta m_{tot} := \delta m_{top} + \delta m_{plug} = 625.078 \text{ gm}$$

Piston length reduction and preload adjustment

New spring data:

Unloaded length: $L_{02} := 340 \text{ mm}$ Fully compressed length: $L_{n2} := 99.6 \text{ mm}$

Stiffness factor: $k_2 := 1.83 \frac{\text{N}}{\text{mm}}$ Max force: $F_{max2} := k_2 \cdot (L_{02} - L_{n2}) = 439.932 \text{ N}$

Current operative piston length:

Spring displacement at current piston length:

$$L_i := 282 \text{ mm}$$

$$x_0 := L_{02} - L_i = 58 \text{ mm}$$

Actual weight before reduction

Weight after previous weight reduction:

$$W_i := 20 \text{ kg} \cdot g = 196.133 \text{ N}$$

$$W_1 := W_i - \delta W_{tot} = 190.003 \text{ N}$$

Weight per length function: $spesweight(A_{cs}, \rho) := A_{cs} \cdot \rho \cdot g$

Weight per length of piston removed: $w_p := spesweight(A_2, \rho) = 0.03 \frac{\text{N}}{\text{mm}}$

weight balancing equation: $A := W_1 - w_p \cdot x = k_2 \cdot (x + 58 \text{ mm})$

$$A \xrightarrow{\text{solve, } x} \frac{6243.1206432147333724 \cdot \text{mm} \cdot \text{mm} \cdot \text{N} - 3487.5477995180034508 \cdot \text{N} \cdot \text{mm}}{\text{N} \cdot \text{mm} + 60.130134474448335358 \cdot \text{N} \cdot \text{mm}}$$

$$x := \frac{3362.8624334883111496 \cdot \text{N} \cdot \text{mm} \cdot \text{mm}}{\text{N} \cdot \text{mm} + 73.123078104605625045 \cdot \text{N} \cdot \text{mm}} = 45.369 \text{ mm}$$

Required piston length reduction:

$$x = 45.369 \text{ mm}$$

Final piston preload:

$$F_{preload} := k_2 \cdot (x + x_0) = 189.165 \text{ N}$$

Weight of elements below
the piston:

$$W_{below} := 1.319 \text{ kg} \cdot g$$

Final weight with ICE-5:

Final mass with ICE-5:

$$W_f := W_1 - x \cdot w_p + W_{below} = 201.557 \text{ N}$$

$$m_f := \frac{W_f}{g} = 20.553 \text{ kg}$$

Final weight of support tool:

Final mass of support tool:

$$W_{tool} := W_f - g \cdot (m_{ice} + m_{socket})$$

$$W_{tool} = 69.952 \text{ N}$$

$$m_{tool} := \frac{W_{tool}}{g} = 7.133 \text{ kg}$$

Shear stress in attachment bolt

Bolt data for 1/4-20UNC

# of threads per inch:	nominal bolt diameter:	pitch:
$n := 20 \cdot \frac{1}{\text{in}}$	$D_n := \frac{1}{4} \text{ in}$	$p := \frac{1}{n} = 0.05 \text{ in}$

Stress area of bolt:

$$SA(D_n, p) := \frac{\pi}{4} \cdot (D_n - 0.9743 \cdot p)^2$$

$$A_s := SA(D_n, p) = 20.53 \text{ mm}^2$$

Shear stress:

$$\tau_{\text{bolt}} := \frac{W_{\text{wrench}}}{A_s} = 6.411 \text{ MPa}$$

Safety factor:

$$SF := \text{safac}(\sigma_{\text{yieldS355}}, \tau_{\text{bolt}}) = 55.378$$

Shear stress in clevis pins

Max stress occurs in the lower clavis pin that connects the piston to the main tube. The max load is set to be equal to the maximum potential spring force.

Max load:

$$F_{\text{max_pin}} := 443.57 \text{ N}$$

Stress area:

$$A_{\text{pin}} := \pi \cdot \left(\frac{6.35 \text{ mm}}{2} \right)^2 = 31.669 \text{ mm}^2$$

Shear stress:

$$\tau_{\text{pin}} := \frac{F_{\text{max_pin}}}{2 \cdot A_{\text{pin}}} = 7.003 \text{ MPa}$$

Safety factor:

$$SF_{\text{pin}} := \text{safac}(\sigma_{\text{yieldS355}}, \tau_{\text{pin}}) = 50.691$$

Piston lock, torsional stress

Properties:

$$D_{PL} := 45 \text{ mm}$$

$$d_{PL} := 43.3 \text{ mm}$$

$$T_{PL} := 120 \text{ N}\cdot\text{m}$$

$$c_{PL} := \frac{D_{PL}}{2} = 22.5 \text{ mm}$$

Max torsional shear stress:

$$mss(T, c, J) := \frac{(T \cdot c)}{J}$$

Polar moment of inertia of hollow cylinder:

$$polar(D, d) := \frac{(\pi \cdot (D^4 - d^4))}{32}$$

Polar moment of inertia:

$$J_1 := polar(D_{PL}, d_{PL}) = (5.747 \cdot 10^4) \text{ mm}^4$$

Maximum shear stress:

$$\tau_{max} := mss(T_{PL}, c_{PL}, J_1) = 46.979 \text{ MPa}$$

Safety factor:

$$SF_{PL} := safac(\sigma_{yieldS355}, \tau_{max}) = 7.557$$

Appendix F, CNC-codes

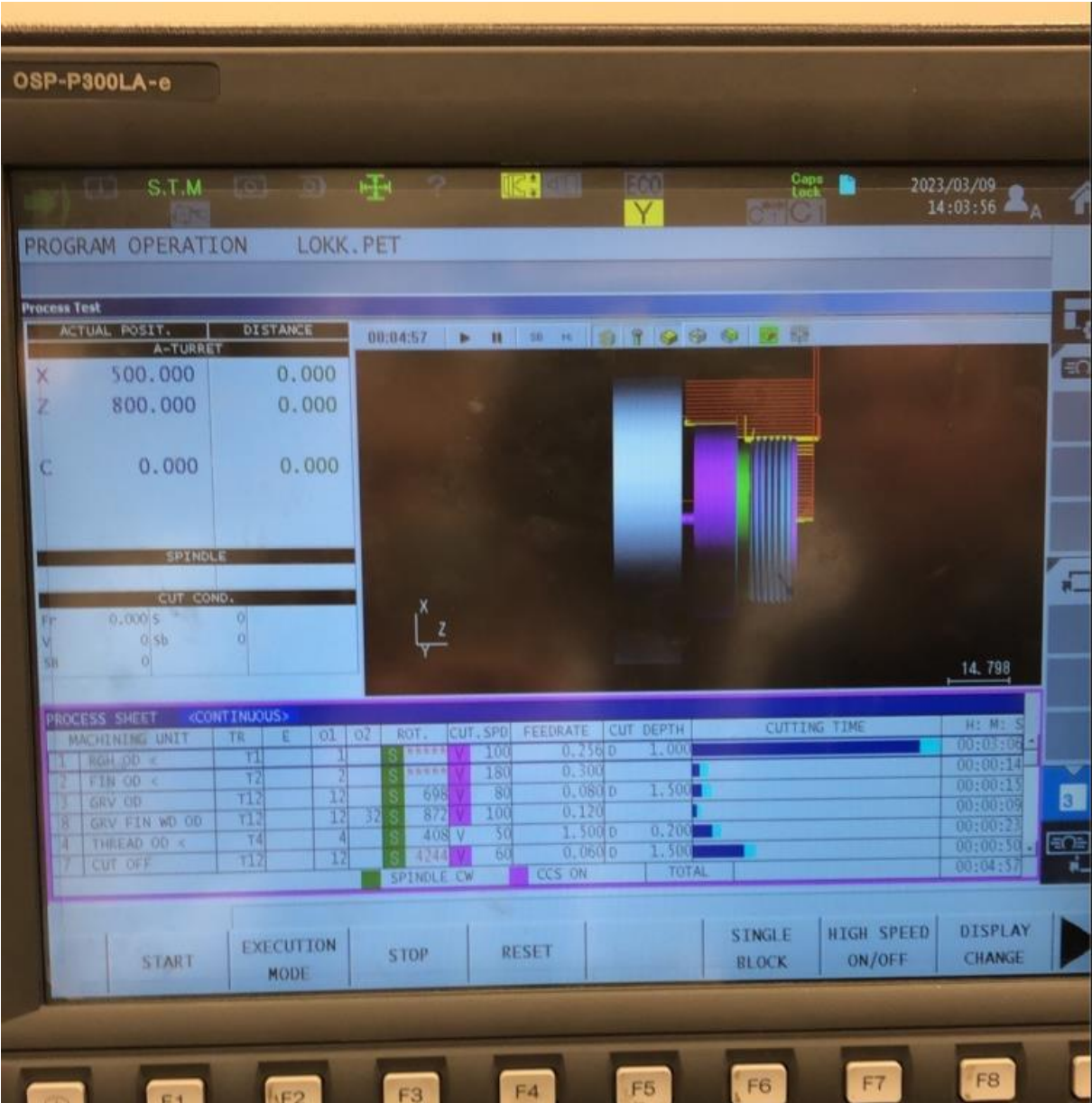

Figure F1 - 1, CNC-code, Piston lock stopper

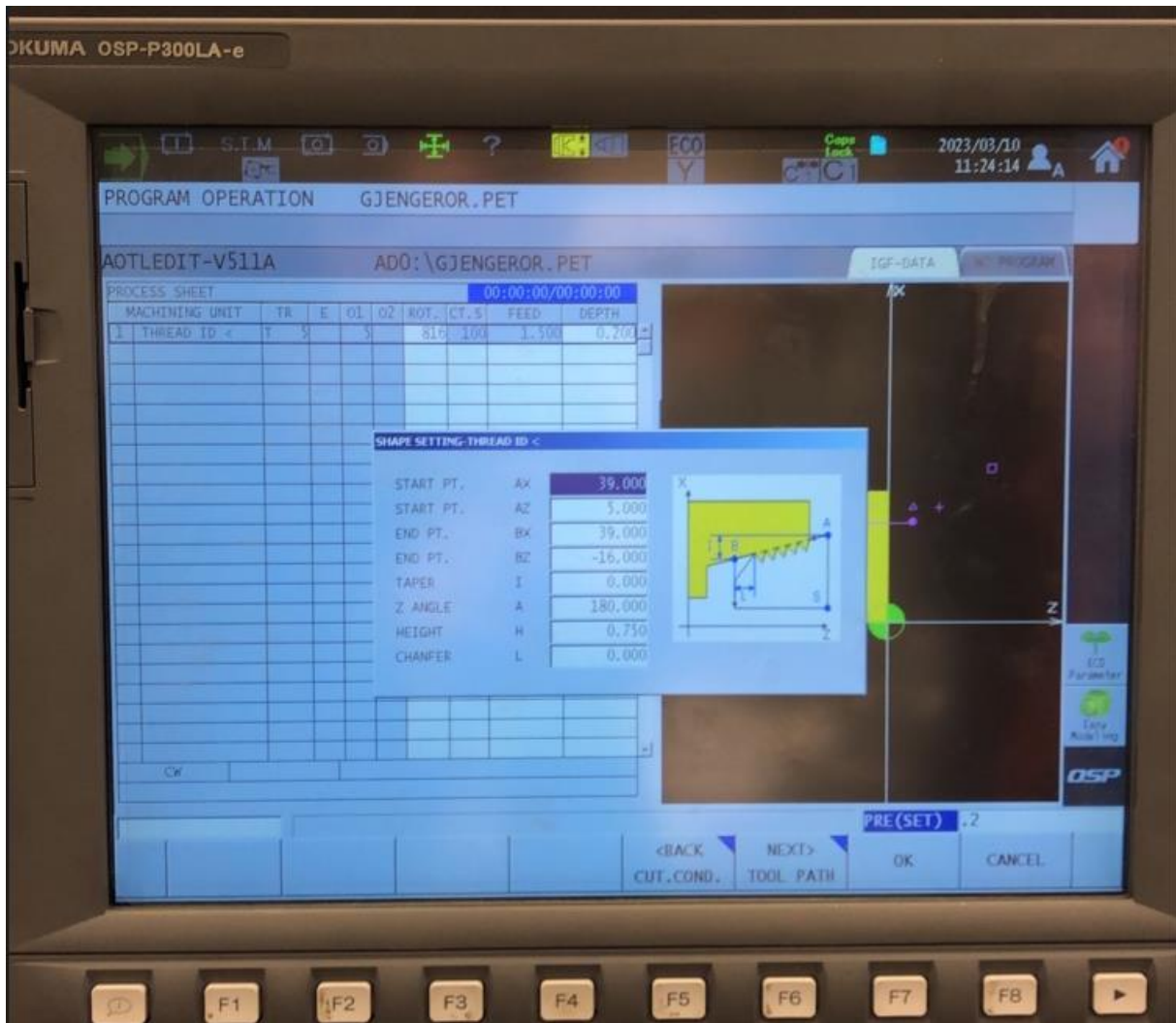

Figure 2F - 2, CNC-code, Inner piston tube

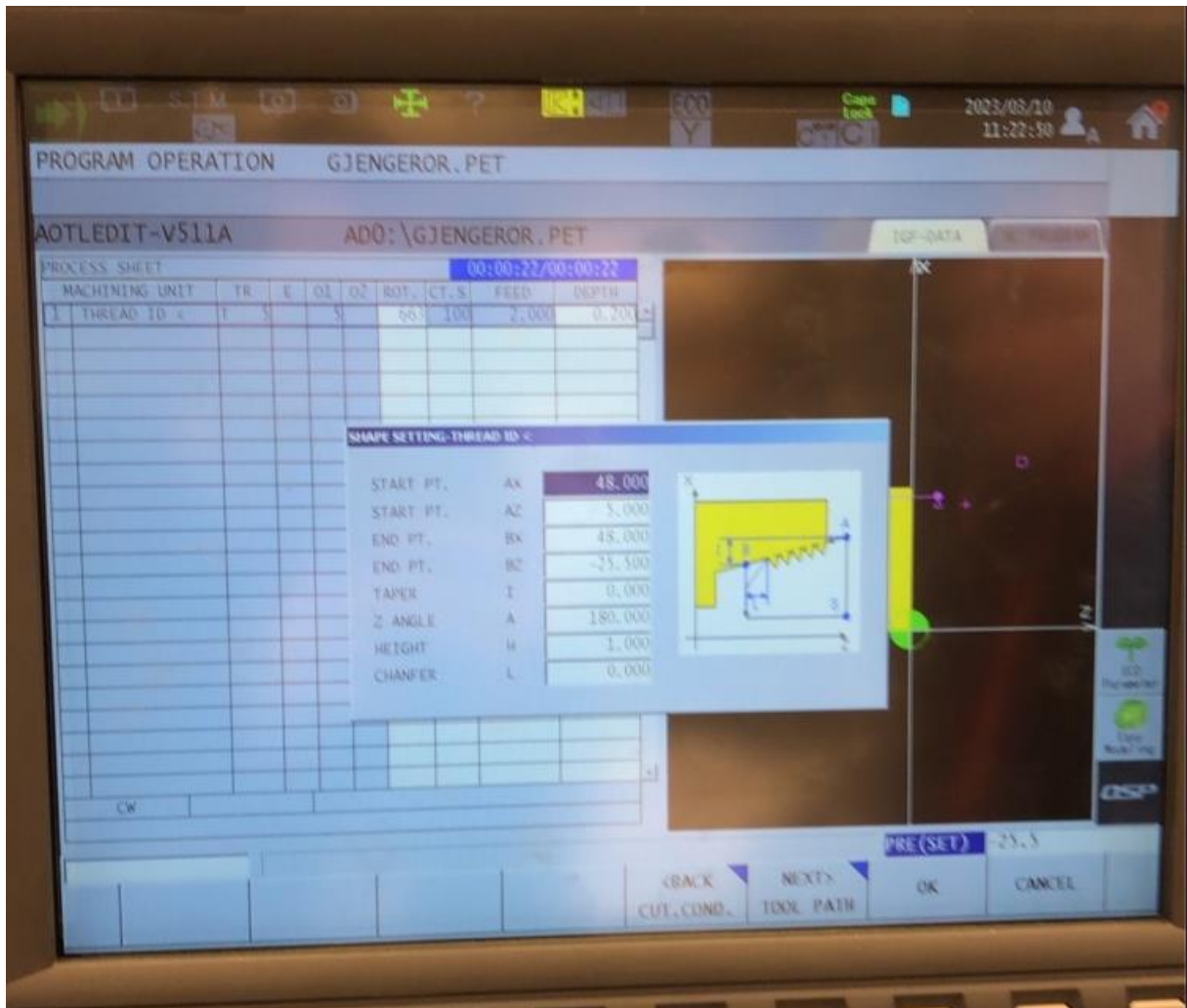

Figure 3F - 3, CNC-code, Outer piston tube - op1

```

File Edit View Setup Help
M640M WNo.1171668326 ( OUTER PISTON TUBE-4 )
UNo. MAT. INITIAL-Z ATC MODE MULTI MODE MULTI FLAG PITCH-X PITCH-Y
0 ST 52 100. 0 OFF @ @ @
UNo. UNIT ADD. WPC X Y th Z C A
1 WPC- 0 -667.7 -234.4 0. -508.965 0.
UNo. UNIT TORNAD DIA DEPTH CHMF BTM PRE-DIA CHMF PITCH1 PITCH2
2 CIRC MIL 1 7. 1. 0. 1 @ @ 0. 0.2
SNo. TOOL NOM-Ø No.HOLE-Ø HOLE-DEP PRE-DIA PRE-DEP RGH DEPTH C-SP FR M M
1 E-MILL 6. H 7. 1. @ CCW 1 C 0. 65 0.1 9
FIG PTN Z X Y AN1 AN2 T1 T2 F M N P Q R
1 PT 0. -27. 0. @ @ @ @ @ @ @ 0 0 0
UNo. UNIT DIA DEPTH CHMF
3 DRILLING 7. 54. 0.
SNo. TOOL NOM-Ø No.HOLE-Ø HOLE-DEP PRE-DIA PRE-DEP RGH DEPTH C-SP FR M M
1 DRILL 7. L 7. 54. 0. 100 PCK1T 0.5 85 0.12 9 51
FIG PTN Z X Y AN1 AN2 T1 T2 F M N P Q R
1 PT 0. -27. 0. @ @ @ @ @ @ @ 0 0 0
UNo. UNIT CONTI.NUMBER ATC X Y Z C A
4 END

```

Figure 4F - 4, CNC-code, Outer piston tube - op2

UNo.	MAT.	OD-MAX	ID-MIN	LENGTH	WORK-FACE	ATC-MODE	RPM							
0	KARB STL	66.	0.	60.	1.		3500.							
*TPC														
UNo.	UNIT	PART	FIN-Z											
1	FACING	0	0.1											
SNo	TOOL	NOM.	No.	PAT.	DEP-1	DEP-2/NUM	DEP-3	FIN-X	FIN-Z	C-SP	FR	M	M	M
R	GNL	OUT	1.	A	<>	0.35	<>	<>	<>	150	0.25	8		
F	GNL	OUT	2.	C	<>	<>	<>	<>	0.	200		8		
FIG	PIN	S-CNR	SPT-X	SPT-Z	FPT-X	FPT-Z	F-CNR/\$	R/th	RGH					
1			66.	1.	0.	0.			5					
UNo.	UNIT	PART	CPT-X		CPT-Z		FIN-X		FIN-Z					
2	BAR	OUT	66.		0.		0.5		0.1					
SNo	TOOL	NOM.	No.	PAT.	DEP-1	DEP-2/NUM	DEP-3	FIN-X	FIN-Z	C-SP	FR	M	M	M
R	GNL	OUT	1.	A	0	1.05	<>	<>	<>	150	0.25	8		
FIG	PIN	S-CNR	SPT-X	SPT-Z	FPT-X	FPT-Z	F-CNR/\$	R/th	RGH					
1	TPR		45.	0.	48.	1.5		45.						
2	LIN		<>	<>	48.	14.5		<>						
3	TPR		48.	14.5	45.	16.		-45.						
4	LIN		<>	<>	45.	18.		<>						
5	LIN	R0.3	<>	<>	55.	54.		<>						
UNo.	UNIT	PART	CPT-X		CPT-Z		FIN-X		FIN-Z					
3	BAR	OUT	56.		0.		0.5		0.1					
SNo	TOOL	NOM.	No.	PAT.	DEP-1	DEP-2/NUM	DEP-3	FIN-X	FIN-Z	C-SP	FR	M	M	M
F	GNL	OUT	2.	C	<>	<>	<>	0.	0.	200		8		
FIG	PIN	S-CNR	SPT-X	SPT-Z	FPT-X	FPT-Z	F-CNR/\$	R/th	RGH					
1	TPR		45.	0.	48.	1.5		45.	5					
2	LIN	R0.3	<>	<>	48.	14.5		<>	5					
3	TPR		48.	14.5	45.	16.		-45.	5					
4	LIN		<>	<>	45.	18.		<>	5					
5	LIN	R0.3	<>	<>	55.	54.		<>	5					
UNo.	MODE	PART	CHAMF		LEAD		ANG		MULTI		HGT			
4	THREAD	OUT	1		2.		59		1		1.29			
SNo	TOOL	NOM.	No.	PAT.	DEP-1	DEP-2/NUM	DEP-3	FIN-X	FIN-Z	C-SP	FR	M	M	M
F	THR	OUT	11.	G	0	<>	10	<>	<>	100	<>	8		
FIG	PIN	S-CNR	SPT-x	SPT-z	FPT-x	FPT-z								
1			48.	0.	48.	17.5								
UNo.	UNIT	MODE	POS-B	POS-C	SRV-Z	SRV-R	RGH	FIN-A	FIN-R	START	END	INTER-R	CHMF	
5	LINE-LFT	XC	<>	<>	32.	2.	6	0.1	0.2	OPEN	OPEN	99.	0.	
SNo	TOOL	NOM-D	No.	APRCH-1	APRCH-2	TYPE	ZFD	DEP-Z	WID-R	C-SP	FR	M	M	M
R	E-MILL	EDGE	16.	H	35.676	103.6711	<>	G01	8.	1.	80	0.3	8	
F	E-MILL	EDGE	16.	H	34.818	105.4149	<>	G01	<>	0.	120	0.2	8	
FIG	PIN	SHIFT-Z	R/X	C/Y	R/th	I	J	P	CNR	R-FEED	RGH			
1	*LINE	50.	x0.	y25.5										
2	LINE	<>	x14.726	y25.5										
3	LINE	<>	x29.453	y0.										
4	LINE	<>	x14.726	y-25.5										
5	LINE	<>	x-14.726	y-25.5										
UNo.	UNIT	PART	DIA											
6	T.DRILL	0	40.											
SNo	TOOL	NOM.	No.	PAT.	DEP-1	DEP-2/NUM	DEP-3	FIN-X	FIN-Z	C-SP	FR	M	M	M
R	DRL	29.	U	1	86.	3.	3.	<>	<>	150	0.12	8		
FIG	PIN	S-CNR	SPT-Z	FPT-Z										
1			0.	86.										
UNo.	UNIT	PART	CPT-X		CPT-Z		FIN-X		FIN-Z					
7	BAR	IN	28.		0.		0.3		0.1					
SNo	TOOL	NOM.	No.	PAT.	DEP-1	DEP-2/NUM	DEP-3	FIN-X	FIN-Z	C-SP	FR	M	M	M
R	GNL	IN	16.	A	0	0.52	<>	<>	<>	100	0.15	8		
F	GNL	IN	16.	A	<>	<>	<>	0.	0.	150		8		
FIG	PIN	S-CNR	SPT-X	SPT-Z	FPT-X	FPT-Z	F-CNR/\$	R/th	RGH					
1	LIN	R0.2	<>	<>	43.	50.		<>	5					
UNo.	UNIT	PART	PAT		No.		PITCH		WIDTH		FINISH			
8	T.GROOVE	OUT	4		1		0.		<>		0.			
SNo	TOOL	NOM.	No.	PAT.	DEP-1	DEP-2/NUM	DEP-3	FIN-X	FIN-Z	C-SP	FR	M	M	M
F	GRV	OUT	2.	S	<>	0.2	<>	<>	<>	60	0.12	8		
FIG	S-CNR	SPT-X	SPT-Z	FPT-X	FPT-Z	F-CNR	ANGLE	RGH						
1	R0.3	55.	50.	43.15				5						
UNo.	UNIT	CONTI.	REPEAT	SHIFT	NUMBER	ATC	RETURN	Work-No.	EXECTE					
9	END								YES					
Shape Pattern														
LIN	TPR	^	^	CENTER		SHAPE								
F1	F2	F3	F4	F5	F6	F7	F8	END						
F9														

Figure 5F - 5, CNC-code, Piston lock

```

File Edit View Setup Help
IN TC MC IN TC + - % ?
M640M WNo.117166S320 ( C-BRACKET-1 )
UNo. MAT. INITIAL-Z ATC MODE MULTI MODE MULTI FLAG PITCH-X PITCH-Y
0 316-L 100. 0 OFF @ @ @
UNo. UNIT ADD. WPC X Y th Z C A
1 WPC- 0 -893.829 -259.499 0. -460.202 0.
UNo. UNIT DIA DEPTH CHMF
2 DRILLING 8. 8. 0.
SNo. TOOL NOM-Ø No.HOLE-Ø HOLE-DEP PRE-DIA PRE-DEP RGH DEPTH C-SP FR M M
1 DRILL 8. S 8. 8. 0. 100 DRILL 4. 75 0.12 9 51
FIG PTN Z X Y AN1 AN2 T1 T2 F M N P Q R
1 PT 0. 50. 0. @ @ @ @ @ @ @ 0 0 0
UNo. UNIT TORNAD DIA DEPTH CHMF BTM PRE-DIA CHMF PITCH1 PITCH2
3 CIRC MIL 1 11. 6. 0. 1 @ @ 0. 0.5
SNo. TOOL NOM-Ø No.HOLE-Ø HOLE-DEP PRE-DIA PRE-DEP RGH DEPTH C-SP FR M M
1 E-MILL 6. H 11. 6. @ CCW 1 C 0. 65 0.1 9 8
FIG PTN Z X Y AN1 AN2 T1 T2 F M N P Q R
1 PT 0. 50. 0. @ @ @ @ @ @ @ 0 0 0
UNo. UNIT DIA DEPTH CHMF
4 DRILLING 11. 10. 0.5
SNo. TOOL NOM-Ø No.HOLE-Ø HOLE-DEP PRE-DIA PRE-DEP RGH DEPTH C-SP FR M M
1 CHF-C 12. V 99. 0. 11. 10. @ C 0.5 100 0.1 9 8
FIG PTN Z X Y AN1 AN2 T1 T2 F M N P Q R
1 PT 0. 50. 0. @ @ @ @ @ @ @ 0 0 0
UNo. UNIT CONTI.NUMBER ATC X Y Z C A
5 END

```

Figure 6F - 6, CNC-code, C-bracket - op1

```

File Edit View Setup Help
M640M WNo.117166S321 ( C-BRACKET-2 )
UNo. MAT. INITIAL-Z ATC MODE MULTI MODE MULTI FLAG PITCH-X PITCH-Y
0 316-L 100. 0 OFF @ @ @
UNo. UNIT ADD. WPC X Y th Z C A
1 WPC- 0 -893.681 -260.304 0. -459.927 0.
UNo. UNIT DIA DEPTH CHMF
2 DRILLING 8. 8. 0.
SNo. TOOL NOM-Ø No.HOLE-Ø HOLE-DEP PRE-DIA PRE-DEP RGH DEPTH C-SP FR M M
1 DRILL 8. S 8. 8. 0. 100 DRILT 4. 75 0.12 9 51
FIG PTN Z X Y AN1 AN2 T1 T2 F M N P Q R
1 PT 0. 50. 0. @ @ @ @ @ @ @ 0 0 0
UNo. UNIT TORNAD DIA DEPTH CHMF BTM PRE-DIA CHMF PITCH1 PITCH2
3 CIRC MIL 1 11. 6. 0. 1 @ @ 0. 0.5
SNo. TOOL NOM-Ø No.HOLE-Ø HOLE-DEP PRE-DIA PRE-DEP RGH DEPTH C-SP FR M M
1 E-MILL 6. H 11. 6. @ CCW 1 C 0. 65 0.1 9 8
FIG PTN Z X Y AN1 AN2 T1 T2 F M N P Q R
1 PT 0. 50. 0. @ @ @ @ @ @ @ 0 0 0
UNo. UNIT TORNAD DIA DEPTH CHMF BTM PRE-DIA CHMF PITCH1 PITCH2
4 CIRC MIL 1 17.08 6. 0. 1 @ @ 0. 0.5
SNo. TOOL NOM-Ø No.HOLE-Ø HOLE-DEP PRE-DIA PRE-DEP RGH DEPTH C-SP FR M M
1 E-MILL 6. H 17.08 6. @ CCW 1 C 0. 65 0.1 9 8
FIG PTN Z X Y AN1 AN2 T1 T2 F M N P Q R
1 PT 0. 50. 0. @ @ @ @ @ @ @ 0 0 0
UNo. UNIT CONTI.NUMBER ATC X Y Z C A
5 END

```

Figure 7F - 7, CNC-code, C-bracket - op2

```

File Edit View Setup Help
M640M WNo.117166S324 ( D2 THREADED CAP CONN.-1 )
UNo. MAT. INITIAL-Z ATC MODE MULTI MODE MULTI FLAG PITCH-X PITCH-Y
0 ST 52 100. 0 OFF @ @ @
UNo. UNIT ADD. WPC X Y th Z C A
1 WPC- 0 -760.465 -254.905 0. -457.597 0.
UNo. UNIT DEPTH SRV-Z BTM WAL FIN-Z FIN-R
2 FACE MIL 0. 22. 1 @ 0.3 @
SNo. TOOL NOM-Ø No.APRCH-X APRCH-Y TYPE ZFD DEP-Z WID-R C-SP FR M M
R 1 E-MILL 40. A -54.543 25. XUN @ 1.5 30. 220 0.6 9
F 2 F-MILL 63. F -67.9 22.4 XUN @ @ 44.1 250 1. 9 8
FIG PTN P1X/CX P1Y/CY P3X/R P3Y CN1 CN2 CN3 CN4
1 SQR -35. 35. 35. -35. R 35. R 35. R 35. R 35.
UNo. UNIT DEPTH INTER-Z INTER-R CHMF
3 CHMF OUT 0. 8. 99. 0.5
SNo. TOOL NOM-Ø No.APRCH-X APRCH-Y TYPE ZFD DEP-Z WID-R C-SP FR M M
1 CHF-C 12. V 2. -36.42 CW G01 @ @ 80 0.2 9 8
FIG PTN P1X/CX P1Y/CY P3X/R P3Y CN1 CN2 CN3 CN4
1 CIR 0. 0. 30. @ @ @ @ @
UNo. UNIT DIA DEPTH CHMF
4 DRILLING 8.8 38. 1.5
SNo. TOOL NOM-Ø No.HOLE-Ø HOLE-DEP PRE-DIA PRE-DEP RGH DEPTH C-SP FR M M
1 CHF-C 6. V 99. 0. 8.8 10. @ C 1.1 80 0.1 8
FIG PTN Z X Y AN1 AN2 T1 T2 F M N P Q R
1 PT 0. 0. 0. @ @ @ @ @ @ @ 0 0 0
UNo. UNIT NOM- MAJOR-Ø PITCH TAP-DEP CHMF CHP
5 TAPPING M10. 10. 1.25 23. 0.8 0
SNo. TOOL NOM-Ø No.HOLE-Ø HOLE-DEP PRE-DIA PRE-DEP RGH DEPTH C-SP FR M M
1 TAP M10. T 10. 23. TAP @ FIX P1.25 7 1.25 9 51
FIG PTN Z X Y AN1 AN2 T1 T2 F M N P Q R
1 PT 0. 0. 0. @ @ @ @ @ @ @ 0 0 0
UNo. UNIT CONTI.NUMBER ATC X Y Z C A
6 END

```

Figure 8F - 8, CNC-code, D2 threaded cap conn. - opl

```

File Edit View Setup Help
M640M WNo.117166S323 ( D2 THREADED CAP CONN.-2 )
UNo. MAT. INITIAL-Z ATC MODE MULTI MODE MULTI FLAG PITCH-X PITCH-Y
0 ST 52 100. 0 OFF @ @ @
UNo. UNIT ADD. WPC X Y th Z C A
1 WPC- 0 -760.201 -254.842 0. -441.56 0. 0.
UNo. UNIT DEPTH SRV-Z SRV-R RGH FIN-Z FIN-R
2 LINE CTR 0. 1. 40. 1 0. @
SNo. TOOL NOM-Ø No.APRCH-X APRCH-Y TYPE ZFD DEP-Z WID-R C-SP FR M M
R 1 F-MILL 63. F 2 -84.5 0. @ G00 1. @ 250 0.6 9 8
FIG PTN X Y R/th I J P CNR
1 LINE -50. 0.
2 LINE 50. 0.
UNo. UNIT DEPTH SRV-Z BTM WAL FIN-Z FIN-R
3 STEP 15. 15. 1 7 0. 0.205
SNo. TOOL NOM-Ø No.APRCH-X APRCH-Y TYPE ZFD DEP-Z WID-R C-SP FR M M
R 1 E-MILL 16. H 4 ? ? CW G01 15. 0.5 200 0.3 9 8
F 2 E-MILL 16. F 6 2. -38.653 CW G01 @ 11.2 220 0.2 9 8
FIG PTN P1X/CX P1Y/CY P3X/R P3Y CN1 CN2 CN3 CN4
1 CIR 0. 0. 33. @ @ @ @ @
2 CIR 0. 0. 30. @ @ @ @ @
UNo. UNIT DEPTH SRV-Z BTM WAL FIN-Z FIN-R
4 STEP 5. 5. 7 7 0.205 0.205
SNo. TOOL NOM-Ø No.APRCH-X APRCH-Y TYPE ZFD DEP-Z WID-R C-SP FR M M
R 1 E-MILL 16. H 4 0. -38.5 CW G01 15. 0.5 200 0.3 9 8
F 2 E-MILL 16. F 6 0. -31. CW G01 @ 11.2 220 0.2 9 8
FIG PTN P1X/CX P1Y/CY P3X/R P3Y CN1 CN2 CN3 CN4
1 CIR 0. 0. 31. @ @ @ @ @
2 CIR 0. 0. 22.6 @ @ @ @ @
UNo. UNIT DEPTH INTER-Z INTER-R CHMF
5 CHMF OUT 0. 5. 99. 0.5
SNo. TOOL NOM-Ø No.APRCH-X APRCH-Y TYPE ZFD DEP-Z WID-R C-SP FR M M
1 CHF-C 12. V 2. -29.006 CW G01 @ @ 110 0.2 9 8
FIG PTN P1X/CX P1Y/CY P3X/R P3Y CN1 CN2 CN3 CN4
1 CIR 0. 0. 22.6 @ @ @ @ @
UNo. UNIT DEPTH INTER-Z INTER-R CHMF
6 CHMF OUT 5. 5. 6. 0.5
SNo. TOOL NOM-Ø No.APRCH-X APRCH-Y TYPE ZFD DEP-Z WID-R C-SP FR M M
1 CHF-C 12. V 2. -36.42 CW G01 @ @ 110 0.2 9 8
FIG PTN P1X/CX P1Y/CY P3X/R P3Y CN1 CN2 CN3 CN4
1 CIR 0. 0. 30. @ @ @ @ @
UNo. UNIT DIA DEPTH CHMF
7 DRILLING 8.8 38. 1.5
SNo. TOOL NOM-Ø No.HOLE-Ø HOLE-DEP PRE-DIA PRE-DEP RGH DEPTH C-SP FR M M
1 DRILL 8.8S 8.8 38. 0. 100 DRILT 4.25 95 0.12 9 51
2 CHF-C 6. V 99. 0. 8.8 10. @ C 1.1 80 0.1 9 8
FIG PTN Z X Y AN1 AN2 T1 T2 F M N P Q R
1 PT 0. 0. 0. @ @ @ @ @ @ @ @ @ @ @ @ @ @ @
UNo. UNIT CONTI.NUMBER ATC X Y Z C A
8 END

```

Figure 9F - 9, CNC-code, D2 threaded cap conn. - op2

```

M640M WNo.117166S237 ( CLAVIS PIN-1 )
UNo. MAT. INITIAL-Z ATC MODE MULTI MODE MULTI FLAG PITCH-X PITCH-Y
0 ST 52 100. 0 OFF @ @ @

UNo. UNIT ADD. WPC X Y th Z C A
1 WPC- 0 -536.49 -211.99 0. -519.676 0.

UNo. UNIT DIA DEPTH CHMF
2 DRILLING 2.5 3. 0.
SNo. TOOL NOM-Ø No.HOLE-Ø HOLE-DEP PRE-DIA PRE-DEP RGH DEPTH C-SP FR M M
1 DRILL 2.5S 2.5 3. 0. 100 PCK2T 0.5 40 0.05 9 51
FIG PTN Z X Y AN1 AN2 T1 T2 F M N P Q R
1 PT 0. -4. 0. @ @ @ @ @ @ @ 0 0 0

UNo. UNIT DIA DEPTH CHMF
3 DRILLING 2.5 5. 0.
SNo. TOOL NOM-Ø No.HOLE-Ø HOLE-DEP PRE-DIA PRE-DEP RGH DEPTH C-SP FR M M
1 DRILL 2.5S 2.5 5. 0. 100 PCK2T 0.5 40 0.05 51 0
FIG PTN Z X Y AN1 AN2 T1 T2 F M N P Q R
1 PT 0. 65. 0. @ @ @ @ @ @ @ 0 0 0

UNo. UNIT DIA DEPTH CHMF
4 DRILLING 2.5 15. 0.
SNo. TOOL NOM-Ø No.HOLE-Ø HOLE-DEP PRE-DIA PRE-DEP RGH DEPTH C-SP FR M M
1 DRILL 2.5S 2.5 15. 0. 100 PCK2T 0.5 40 0.05 51 0
FIG PTN Z X Y AN1 AN2 T1 T2 F M N P Q R
1 PT 0. -4. 0. @ @ @ @ @ @ @ 0 0 0

UNo. UNIT DIA DEPTH CHMF
5 DRILLING 2.5 12. 0.
SNo. TOOL NOM-Ø No.HOLE-Ø HOLE-DEP PRE-DIA PRE-DEP RGH DEPTH C-SP FR M M
1 DRILL 2.5S 2.5 12. 0. 100 PCK2T 0.5 40 0.05 51 0
FIG PTN Z X Y AN1 AN2 T1 T2 F M N P Q R
1 PT 0. 65. 0. @ @ @ @ @ @ @ 0 0 0

UNo. UNIT CONTI.NUMBER ATC X Y Z C A
6 END 0

```

Figure 10F - 10, CNC-code, Clevis pin - op2

```

M640M WNo.117166S235 ( ATTACHMENT BOLT-1 )
UNo. MAT. INITIAL-Z ATC MODE MULTI MODE MULTI FLAG PITCH-X PITCH-Y
0 ALUMINIUM 100. 0 OFF @ @ @

UNo. UNIT ADD. WPC X Y th Z C A
1 WPC- 0 -480.242 -211.83 0. -523.682 0.

UNo. UNIT DEPTH SRV-Z SRV-R RGH FIN-Z FIN-R
2 LINE CTR 0. 1. 3. 1 0. @
SNo. TOOL NOM-Ø No.APRCH-X APRCH-Y TYPE ZFD DEP-Z WID-R C-SP FR M M
R 1 E-MILL 4. H 15. 0. @ G01 1. @ 65 0.1 9 51
FIG PTN X Y R/th I J P CNR
1 LINE 10. 0.
2 LINE -11. 0.
3 LINE -9. 0.

UNo. UNIT DEPTH SRV-Z SRV-R RGH FIN-Z FIN-R
3 LINE CTR 0. 1. 3. 1 0. @
SNo. TOOL NOM-Ø No.APRCH-X APRCH-Y TYPE ZFD DEP-Z WID-R C-SP FR M M
R 1 E-MILL 4. H 15. 0. @ G01 1. @ 65 0.1 9 51
FIG PTN X Y R/th I J P CNR
1 LINE 10. 0.
2 LINE 5. 0.
3 LINE 5. 0.65
4 LINE -11. 0.65
5 LINE -11. -0.65
6 LINE 6. -0.65
7 LINE 6. 0.
8 LINE 10. 0.

UNo. UNIT CONTI.NUMBER ATC X Y Z C A
4 END 0

```

Figure 11F - 11, CNC-code, Attachment bolt - op2

```

M640M WNo.117166S230 ( HANDLE-1 )
UNo. MAT. INITIAL-Z ATC MODE MULTI MODE MULTI FLAG PITCH-X PITCH-Y
0 ST 52 100. 0 OFF @ @ @

UNo. UNIT ADD. WPC X Y th Z C A
1 WPC- 0 -472.031 -225.347 0. -514.713 0.

UNo. UNIT DIA DEPTH CHMF
2 DRILLING 6. 15. 0.5
SNo. TOOL NOM-Ø No.HOLE-Ø HOLE-DEP PRE-DIA PRE-DEP RGH DEPTH C-SP FR M M
1 CTR-DR 20. V 7.5 @ @ @ 90° CTR-D 20 0.1 9 8
FIG PTN Z X Y AN1 AN2 T1 T2 F M N P Q R
1 PT 0. 0. 0. @ @ @ @ @ @ @ 0 0 0

UNo. UNIT TORNAD DIA DEPTH CHMF BTM PRE-DIA CHMF PITCH1 PITCH2
3 CIRC MIL 1 6.1 15. 0. 1 @ @ 0. 0.5
SNo. TOOL NOM-Ø No.HOLE-Ø HOLE-DEP PRE-DIA PRE-DEP RGH DEPTH C-SP FR M M
1 E-MILL 4. H 6.1 15. @ CCW 1 C 0. 65 0.08 9 51
FIG PTN Z X Y AN1 AN2 T1 T2 F M N P Q R
1 PT 0. 0. 0. @ @ @ @ @ @ @ 0 0 0

UNo. UNIT CONTI.NUMBER ATC X Y Z C A
4 END 0

```

Figure 12F - 12, CNC-code, Handle - op1

```

M640M WNo.117166S231 ( HANDLE-2 )
UNo. MAT. INITIAL-Z ATC MODE MULTI MODE MULTI FLAG PITCH-X PITCH-Y
0 ST 52 100. 0 OFF @ @ @

UNo. UNIT ADD. WPC X Y th Z C A
1 WPC- 0 -466.505 -227.051 0. -501.19 0.

UNo. UNIT TORNAD DIA DEPTH CHMF BTM PRE-DIA CHMF PITCH1 PITCH2
2 CIRC MIL 1 5.1 1. 0. 1 @ @ 0. 0.2
SNo. TOOL NOM-Ø No.HOLE-Ø HOLE-DEP PRE-DIA PRE-DEP RGH DEPTH C-SP FR M M
1 E-MILL 4. H 5.1 1. @ CCW 1 C 0. 65 0.07 9 51
FIG PTN Z X Y AN1 AN2 T1 T2 F M N P Q R
1 PT 0. 0. 7.5 @ @ @ @ @ @ @ 0 0 0

UNo. UNIT NOM- MAJOR-Ø PITCH TAP-DEP CHMF CHP
3 TAPPING M 6. 6. 1. 16. 0.5 0
SNo. TOOL NOM-Ø No.HOLE-Ø HOLE-DEP PRE-DIA PRE-DEP RGH DEPTH C-SP FR M M
1 DRILL 5.1S 5.1 16. 0. 100 PCK1T 1. 70 0.1 9 51
2 CTR-DR 20. V 6.7 @ @ @ 90° CTR-D 20 0.1 9 8
3 TAP M 6. B 6. 15.9 TAP @ FIX P1. 7 1. 9 0
FIG PTN Z X Y AN1 AN2 T1 T2 F M N P Q R
1 PT 0. 0. 7.5 @ @ @ @ @ @ @ 0 0 0

UNo. UNIT CONTI.NUMBER ATC X Y Z C A
4 END 0

```

Figure 13F - 13, CNC-code, Handle - op2

```

File Edit View Setup Help
M640M WNo.117166S305 ( MAIN TUBE-1 )
UNo. MAT. INITIAL-Z ATC MODE MULTI MODE MULTI FLAG PITCH-X PITCH-Y
0 ST 52 100. 0 OFF @ @ @

UNo. UNIT ADD. WPC X Y th Z C A
1 WPC- 0 -411.778 -239.06 0. -500.046 0.

UNo. UNIT TORNAD DIA DEPTH CHMF BTM PRE-DIA CHMF PITCH1 PITCH2
2 CIRC MIL 1 7. 1.5 0. 8 @ @ 0. 0.3
SNo. TOOL NOM-Ø No.HOLE-Ø HOLE-DEP PRE-DIA PRE-DEP RGH DEPTH C-SP FR M M
1 E-MILL 6. H 7. 1.5 @ CCW 8 C 0. 85 0.1 9 8
FIG PTN Z X Y AN1 AN2 T1 T2 F M N P Q R
1 PT 0. -83. 0. @ @ @ @ @ @ @ 0 0 0

UNo. UNIT TORNAD DIA DEPTH CHMF BTM PRE-DIA CHMF PITCH1 PITCH2
3 CIRC MIL 1 6.8 1.5 0. 8 @ @ 0. 0.3
SNo. TOOL NOM-Ø No.HOLE-Ø HOLE-DEP PRE-DIA PRE-DEP RGH DEPTH C-SP FR M M
1 E-MILL 6. H 6.8 1.5 @ CCW 8 C 0. 85 0.1 9 8
FIG PTN Z X Y AN1 AN2 T1 T2 F M N P Q R
1 PT 0. -470. 0. @ @ @ @ @ @ @ 0 0 0

UNo. UNIT DIA DEPTH CHMF
4 DRILLING 7. 64. 0.
SNo. TOOL NOM-Ø No.HOLE-Ø HOLE-DEP PRE-DIA PRE-DEP RGH DEPTH C-SP FR M M
1 DRILL 7. L 7. 64. 0. 100 PCK1T 1. 85 0.15 9 51
FIG PTN Z X Y AN1 AN2 T1 T2 F M N P Q R
1 PT 0. -83. 0. @ @ @ @ @ @ @ 0 0 0

UNo. UNIT NOM- MAJOR-Ø PITCH TAP-DEP CHMF CHP
5 TAPPING M 8. 8. 1.25 10. 0.6 0
SNo. TOOL NOM-Ø No.HOLE-Ø HOLE-DEP PRE-DIA PRE-DEP RGH DEPTH C-SP FR M M
1 DRILL 6.8 6.8 11. 0. 100 DRILT 3.4 85 0.1 9 51
2 CHF-C 12. V 99. 0. 6.8 10. @ C 0.5 100 0.1 9 8
3 TAP M 8. 8. 10. TAP @ FIX P1.25 7 1.25 9 51
FIG PTN Z X Y AN1 AN2 T1 T2 F M N P Q R
1 PT 0. -470. 0. @ @ @ @ @ @ @ 0 0 0

UNo. UNIT CONTI.NUMBER ATC X Y Z C A
6 END

```

Figure 14F - 14, CNC-code, Main tube - opl

```

File Edit View Setup Help
M640M WNo.117166S306 ( MAIN TUBE-2 )
UNo. MAT. INITIAL-Z ATC MODE MULTI MODE MULTI FLAG PITCH-X PITCH-Y
0 ST 52 100. 0 OFF @ @ @
UNo. UNIT ADD. WPC X Y th Z C A
1 WPC- 0 -994.734 -238.948 0. -499.814 0.
UNo. UNIT TORNAD DIA DEPTH CHMF BTM PRE-DIA CHMF PITCH1 PITCH2
2 CIRC MIL 1 7. 1.5 0. 8 @ @ 0. 0.3
SNo. TOOL NOM-Ø No.HOLE-Ø HOLE-DEP PRE-DIA PRE-DEP RGH DEPTH C-SP FR M M
1 E-MILL 6. H 7. 1.5 @ CCW 8 C 0. 85 0.1 9 8
FIG PTN Z X Y AN1 AN2 T1 T2 F M N P Q R
1 PT 0. 470. 0. @ @ @ @ @ @ @ 0 0 0
UNo. UNIT DIA DEPTH CHMF
3 DRILLING 7. 64. 0.
SNo. TOOL NOM-Ø No.HOLE-Ø HOLE-DEP PRE-DIA PRE-DEP RGH DEPTH C-SP FR M M
1 DRILL 7. L 7. 64. 0. 100 PCK1T 1. 85 0.15 9 51
FIG PTN Z X Y AN1 AN2 T1 T2 F M N P Q R
1 PT 0. 470. 0. @ @ @ @ @ @ @ 0 0 0
UNo. UNIT CONTI.NUMBER ATC X Y Z C A
4 END 0

```

Figure 15F - 15, CNC-code, Main tube - op2

```

File Edit View Setup Help
M640M WNo.117166S309 ( TOP TUBE-1 )
UNo. MAT. INITIAL-Z ATC MODE MULTI MODE MULTI FLAG PITCH-X PITCH-Y
0 ST 52 100. 0 OFF @ @ @
UNo. UNIT ADD. WPC X Y th Z C A
1 WPC- 0 -932.989 -234.506 0. -500.311 0.
UNo. UNIT TORNAD DIA DEPTH CHMF BTM PRE-DIA CHMF PITCH1 PITCH2
2 CIRC MIL 1 7. 1.5 0. 8 @ @ 0. 0.3
SNo. TOOL NOM-Ø No.HOLE-Ø HOLE-DEP PRE-DIA PRE-DEP RGH DEPTH C-SP FR M M
1 E-MILL 6. H 7. 1.5 @ CCW 8 C 0. 85 0.1 9 8
FIG PTN Z X Y AN1 AN2 T1 T2 F M N P Q R
1 LIN 0. 30. 0. 0. @ 45. @ 0 8 @ @ 0 0
UNo. UNIT DIA DEPTH CHMF
3 DRILLING 7. 54. 0.
SNo. TOOL NOM-Ø No.HOLE-Ø HOLE-DEP PRE-DIA PRE-DEP RGH DEPTH C-SP FR M M
1 DRILL 7. L 7. 54. 0. 100 PCK1T 1. 85 0.15 9 51
FIG PTN Z X Y AN1 AN2 T1 T2 F M N P Q R
1 LIN 0. 30. 0. 0. @ 45. @ 0 8 @ @ 0 0
UNo. UNIT CONTI.NUMBER ATC X Y Z C A
4 END 0

```

Figure 16F - 16, CNC-code, Top tube - op1

```

File Edit View Setup Help
M640M WNo.117166S310 ( TOP TUBE-2 )
UNo. MAT. INITIAL-Z ATC MODE MULTI MODE MULTI FLAG PITCH-X PITCH-Y
0 ST 52 100. 0 OFF @ @ @

UNo. UNIT ADD. WPC X Y th Z C A
1 WPC- 0 -948.157 -234.427 0. -500.25 0.

UNo. UNIT TORNAD DIA DEPTH CHMF BTM PRE-DIA CHMF PITCH1 PITCH2
2 CIRC MIL 1 7. 1.5 0. 8 @ @ 0. 0.3
SNo. TOOL NOM-Ø No.HOLE-Ø HOLE-DEP PRE-DIA PRE-DEP RGH DEPTH C-SP FR M M
1 E-MILL 6. H 7. 1.5 @ CCW 8 C 0. 85 0.1 9 8
FIG PTN Z X Y AN1 AN2 T1 T2 F M N P Q R
1 PT 0. 24. 0. @ @ @ @ @ @ @ 0 0 0

UNo. UNIT DIA DEPTH CHMF
3 DRILLING 7. 8. 0.
SNo. TOOL NOM-Ø No.HOLE-Ø HOLE-DEP PRE-DIA PRE-DEP RGH DEPTH C-SP FR M M
1 DRILL 7. L 7. 8. 0. 100 PCK1T 0.5 85 0.15 9 51
FIG PTN Z X Y AN1 AN2 T1 T2 F M N P Q R
1 PT 0. 24. 0. @ @ @ @ @ @ @ 0 0 0

UNo. UNIT DEPTH SRV-Z SLOT-WID BTM WAL FIN-Z FIN-R
4 SLOT 4. 4. 8.7 1 8 0. 0.1
SNo. TOOL NOM-Ø No.APRCH-X APRCH-Y TYPE ZFD DEP-Z WID-R C-SP FR M M
R 1 E-MILL 6. H 24. 0. CCW G01 2. @ 75 0.1 9 8
F 2 E-MILL 6. H 24. 0. CCW G01 @ @ 80 0.1 8
FIG PTN X Y R/th I J P CNR
1 LINE 24. 0.
2 LINE 355. 0.

UNo. UNIT CONTI.NUMBER ATC X Y Z C A
5 END 0

```

Figure 17F - 17, CNC-code, Top tube- op2

```

File Edit View Setup Help
M640M WNo.117166 ( WELDED PISTON PLUG-1 )
UNo. MAT. INITIAL-Z ATC MODE MULTI MODE MULTI FLAG PITCH-X PITCH-Y
0 ST 52 100. 0 OFF @ @ @

UNo. UNIT ADD. WPC X Y th Z C A
1 WPC- 0 -845.352 -228.702 0. -469.134 0.

UNo. UNIT DEPTH SRV-Z BTM WAL FIN-Z FIN-R
2 FACE MIL 0. 1. 1 @ 0. @

SNo. TOOL NOM-Ø No.APRCH-X APRCH-Y TYPE ZFD DEP-Z WID-R C-SP FR M M
R 1 E-MILL 25. A 43.084 -30. XUN @ 1. 17.5 250 0.4 9

FIG PTN P1X/CX P1Y/CY P3X/R P3Y CN1 CN2 CN3 CN4
1 SQR 35. -35. -35. 35. R 35. R 35. R 35. R 35.

UNo. UNIT DEPTH SRV-Z SRV-R RGH FIN-Z FIN-R
3 LINE OUT 49. 49. 18. 7 0. 0.1

SNo. TOOL NOM-Ø No.APRCH-X APRCH-Y TYPE ZFD DEP-Z WID-R C-SP FR M M
R 1 E-MILL 40. A 2. -68.971 CW G00 5. @ 300 0.5 9

FIG PTN P1X/CX P1Y/CY P3X/R P3Y CN1 CN2 CN3 CN4
1 CIR 0. 0. 28. @ @ @ @ @

UNo. UNIT DEPTH SRV-Z SRV-R RGH FIN-Z FIN-R
4 LINE OUT 49. 49. 18. 7 0. 0.1

SNo. TOOL NOM-Ø No.APRCH-X APRCH-Y TYPE ZFD DEP-Z WID-R C-SP FR M M
R 1 E-MILL 40. A 2. -64.068 CW G00 5. @ 300 0.5 9

FIG PTN P1X/CX P1Y/CY P3X/R P3Y CN1 CN2 CN3 CN4
1 CIR 0. 0. 23.1 @ @ @ @ @

UNo. UNIT DEPTH INTER-Z INTER-R CHMF
5 CHMF OUT 0. 99. 99. 1.

SNo. TOOL NOM-Ø No.APRCH-X APRCH-Y TYPE ZFD DEP-Z WID-R C-SP FR M M
1 CHF-C 12. V 2. -29.757 CW G00 @ @ 100 0.3 9 8

FIG PTN P1X/CX P1Y/CY P3X/R P3Y CN1 CN2 CN3 CN4
1 CIR 0. 0. 23.1 @ @ @ @ @

UNo. UNIT DEPTH SRV-Z SRV-R RGH FIN-Z FIN-R
6 LINE OUT 49. 49. 15. 7 0.2 0.

SNo. TOOL NOM-Ø No.APRCH-X APRCH-Y TYPE ZFD DEP-Z WID-R C-SP FR M M
R 1 E-MILL 16. H 2. -48.608 CW G00 10. @ 250 0.4 9 8

FIG PTN P1X/CX P1Y/CY P3X/R P3Y CN1 CN2 CN3 CN4
1 CIR 0. 0. 22.65 @ @ @ @ @

UNo. UNIT CONTI.NUMBER ATC X Y Z C A
7 END 0

```

Figure 18F - 18, CNC-code, Welded piston plug - op1

```

File Edit View Setup Help
M640M WNo.117166S301 ( WELDED PISTON PLUG-2 )
UNo. MAT. INITIAL-Z ATC MODE MULTI MODE MULTI FLAG PITCH-X PITCH-Y
0 ST 52 100. 0 OFF @ @ @

UNo. UNIT ADD. WPC X Y th Z C A
1 WPC- 0 -844.273 -237.437 0. -513.378 0.

UNo. UNIT DEPTH SRV-Z BTM WAL FIN-Z FIN-R
2 FACE MIL 0. 6. 1 @ 0. @

SNo. TOOL NOM-Ø No.APRCH-X APRCH-Y TYPE ZFD DEP-Z WID-R C-SP FR M M
R 1 E-MILL 25. A 43.084 -30. XUN @ 1. 17.5 250 0.4 9

FIG PTN P1X/CX P1Y/CY P3X/R P3Y CN1 CN2 CN3 CN4
1 SQR 35. -35. -35. 35. R 35. R 35. R 35. R 35.

UNo. UNIT DEPTH SRV-Z SRV-R RGH FIN-Z FIN-R
3 LINE OUT 13. 13. 18. 7 0. 0.1

SNo. TOOL NOM-Ø No.APRCH-X APRCH-Y TYPE ZFD DEP-Z WID-R C-SP FR M M
R 1 E-MILL 40. A 2. -70.971 CW G00 5. @ 300 0.5 9

FIG PTN P1X/CX P1Y/CY P3X/R P3Y CN1 CN2 CN3 CN4
1 CIR 0. 0. 30. @ @ @ @ @

UNo. UNIT DEPTH SRV-Z SRV-R RGH FIN-Z FIN-R
4 LINE OUT 6. 6. 18. 7 0. 0.

SNo. TOOL NOM-Ø No.APRCH-X APRCH-Y TYPE ZFD DEP-Z WID-R C-SP FR M M
R 1 E-MILL 40. A 2. -63.468 CW G00 6. @ 300 0.5 9

FIG PTN P1X/CX P1Y/CY P3X/R P3Y CN1 CN2 CN3 CN4
1 CIR 0. 0. 22.5 @ @ @ @ @

UNo. UNIT DEPTH INTER-Z INTER-R CHMF
5 CHMF OUT 0. 99. 99. 1.

SNo. TOOL NOM-Ø No.APRCH-X APRCH-Y TYPE ZFD DEP-Z WID-R C-SP FR M M
1 CHF-C 12. V 2. -29.156 CW G00 @ @ 100 0.2 9 8

FIG PTN P1X/CX P1Y/CY P3X/R P3Y CN1 CN2 CN3 CN4
1 CIR 0. 0. 22.5 @ @ @ @ @

UNo. UNIT CONTI.NUMBER ATC X Y Z C A
6 END 0

```

Figure 19F - 19, CNC-code, Welded piston plug - op2

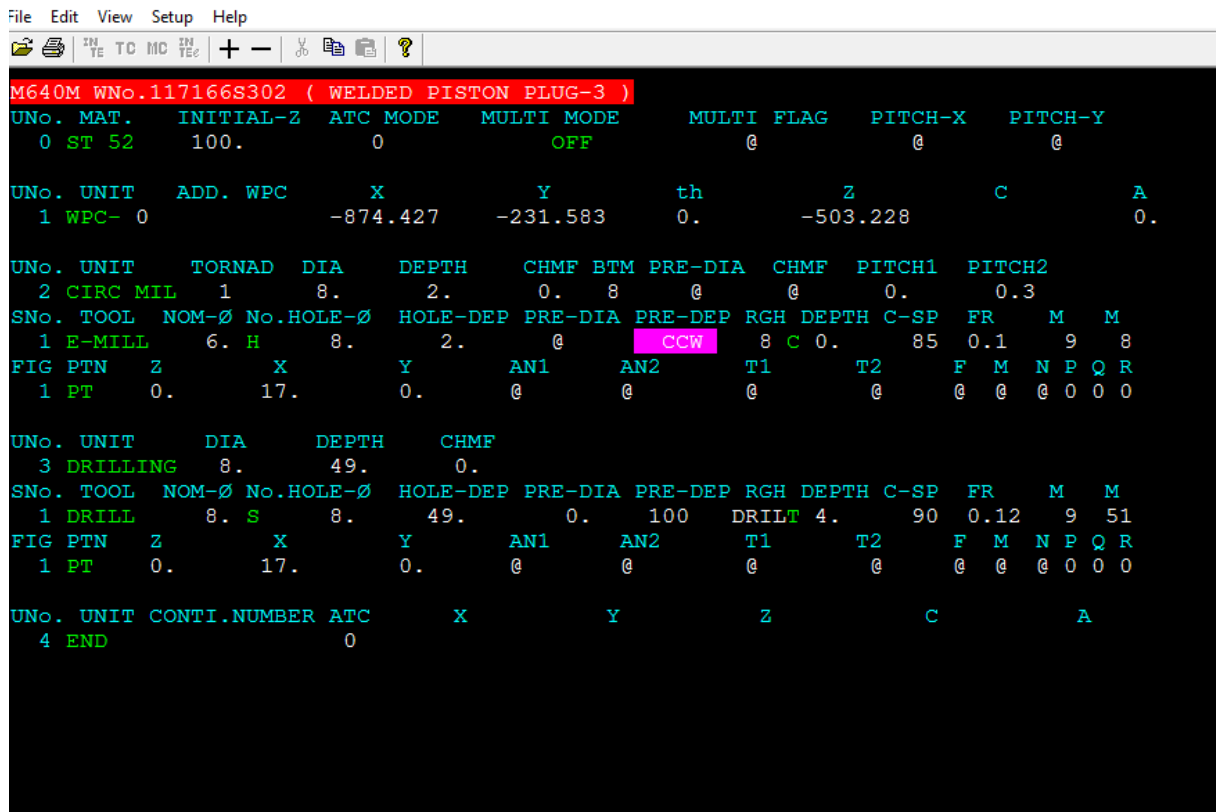

Figure 20F - 20, CNC-code, Welded piston plug - op3

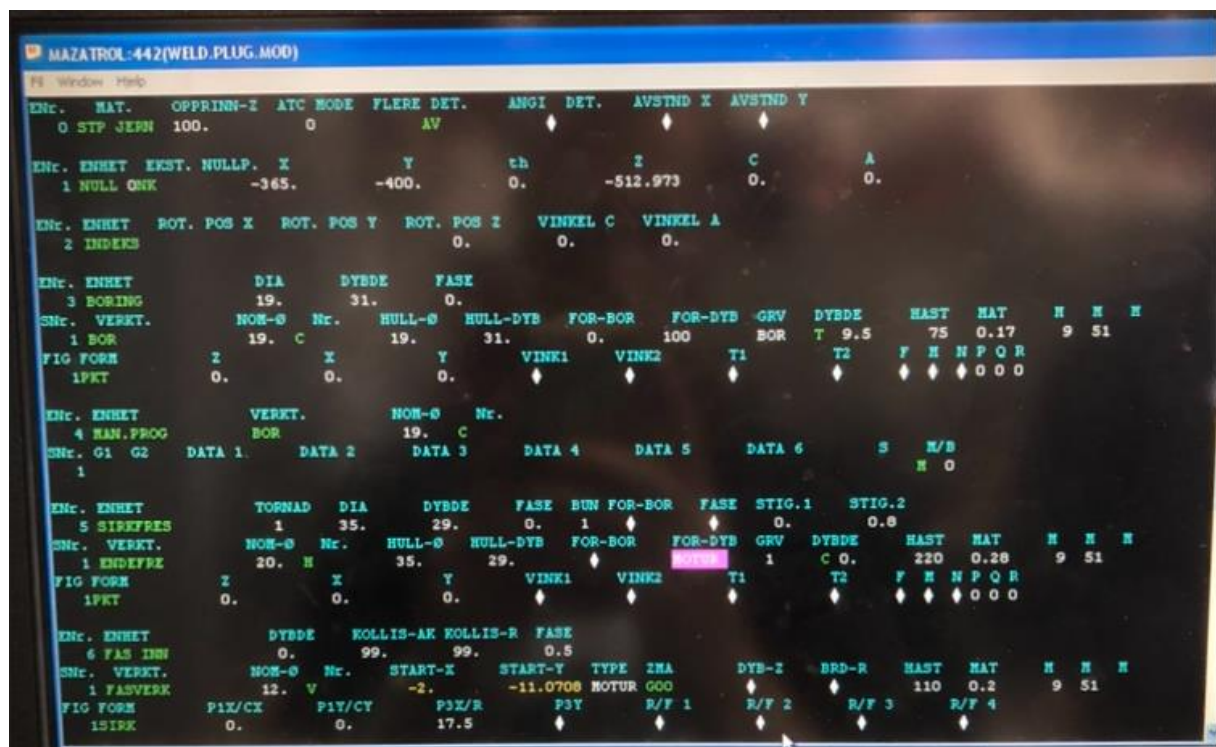

Figure 21F - 21, CNC-code, Welded piston plug – refinement

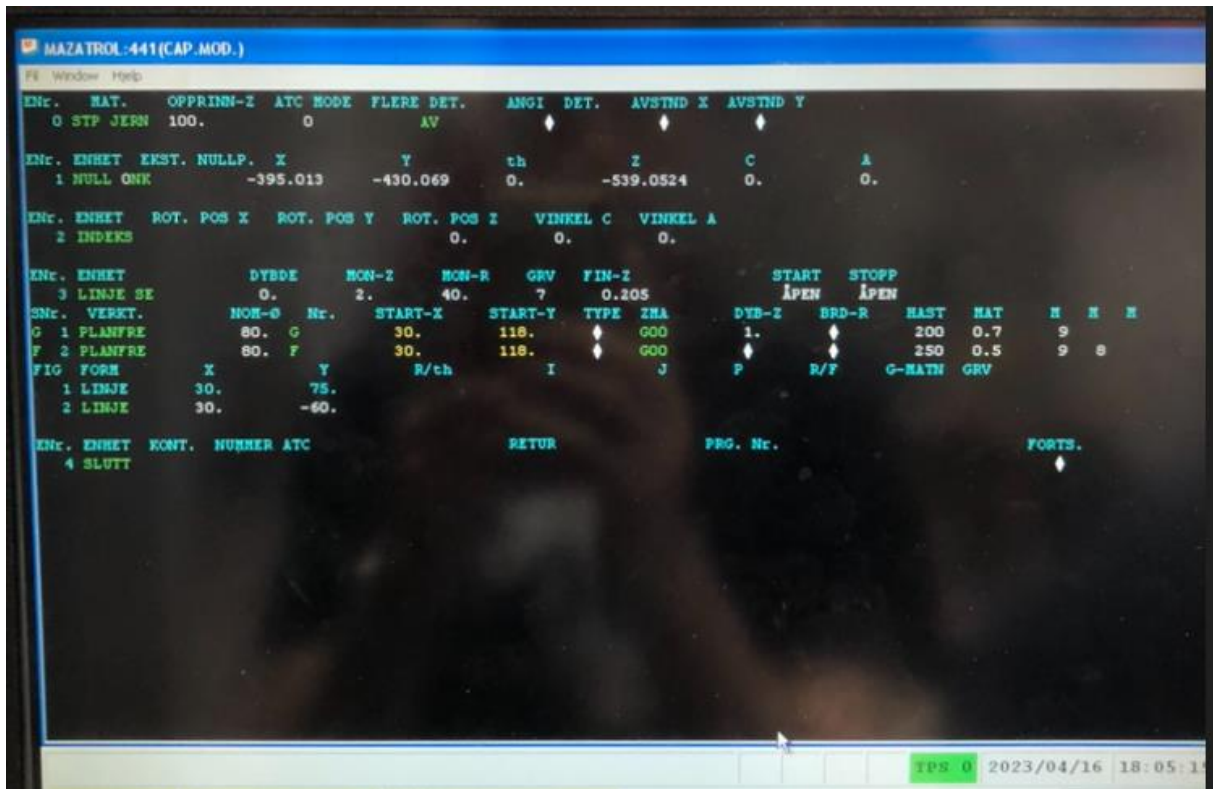

Figure 24 F - 24, CNC-code, D2 threaded cap conn. – refinement

Appendix H, Manufacturing plan

Table 1, MP - Inner piston tube

Part:	Inner piston tube																
DWG no.	SM-Bsc-015																
Rev:	1																
<table border="1"> <thead> <tr> <th>No.</th> <th>Process:</th> <th>Information:</th> </tr> </thead> <tbody> <tr> <td>1</td> <td>Band saw</td> <td>Cut material OD42,4 pipe to 305mm length</td> </tr> <tr> <td>2</td> <td>Machining</td> <td>Lathe, turn internal thread M39x1,5. chamfer and full length 300mm.</td> </tr> <tr> <td>3</td> <td>polishing</td> <td>May need a polishing-operation of the OD to be able to glide properly with the ID of "piston lock".</td> </tr> <tr> <td>4</td> <td>Assembly</td> <td>Assembling to Part 13.</td> </tr> </tbody> </table>			No.	Process:	Information:	1	Band saw	Cut material OD42,4 pipe to 305mm length	2	Machining	Lathe, turn internal thread M39x1,5. chamfer and full length 300mm.	3	polishing	May need a polishing-operation of the OD to be able to glide properly with the ID of "piston lock".	4	Assembly	Assembling to Part 13.
No.	Process:	Information:															
1	Band saw	Cut material OD42,4 pipe to 305mm length															
2	Machining	Lathe, turn internal thread M39x1,5. chamfer and full length 300mm.															
3	polishing	May need a polishing-operation of the OD to be able to glide properly with the ID of "piston lock".															
4	Assembly	Assembling to Part 13.															
Remark:																	

Table 2, MP - TPU foot

Part:	TPU foot													
DWG no.	SM-Bsc-016													
Rev:	1													
<table border="1"> <thead> <tr> <th>No.</th> <th>Process:</th> <th>Information:</th> </tr> </thead> <tbody> <tr> <td>1</td> <td>Slicing</td> <td>Apply relevant information into slicer</td> </tr> <tr> <td>2</td> <td>Print</td> <td>Prusa, TPU filament, start print</td> </tr> <tr> <td>3</td> <td>Assemble</td> <td>TPU foot to be assembled with <i>Inner Piston Tube</i>, out of the 2 printed parts choose the one with best fit.</td> </tr> </tbody> </table>			No.	Process:	Information:	1	Slicing	Apply relevant information into slicer	2	Print	Prusa, TPU filament, start print	3	Assemble	TPU foot to be assembled with <i>Inner Piston Tube</i> , out of the 2 printed parts choose the one with best fit.
No.	Process:	Information:												
1	Slicing	Apply relevant information into slicer												
2	Print	Prusa, TPU filament, start print												
3	Assemble	TPU foot to be assembled with <i>Inner Piston Tube</i> , out of the 2 printed parts choose the one with best fit.												
Remark:														

Table 3, MP - Piston lock

Part:		Piston lock												
DWG no.		SM-Bsc-014												
Rev:		2												
<table border="1"> <thead> <tr> <th>No.</th> <th>Process:</th> <th>Information:</th> </tr> </thead> <tbody> <tr> <td>1</td> <td>Band saw</td> <td>Bolt OD 65. Cut material to length: 80mm</td> </tr> <tr> <td>2</td> <td>Machining</td> <td>Lathe. turn thread M48x2. Milling Operations Lathe operations</td> </tr> <tr> <td>3</td> <td>Assembly</td> <td>Assemble with <i>Outer piston</i></td> </tr> </tbody> </table>			No.	Process:	Information:	1	Band saw	Bolt OD 65. Cut material to length: 80mm	2	Machining	Lathe. turn thread M48x2. Milling Operations Lathe operations	3	Assembly	Assemble with <i>Outer piston</i>
No.	Process:	Information:												
1	Band saw	Bolt OD 65. Cut material to length: 80mm												
2	Machining	Lathe. turn thread M48x2. Milling Operations Lathe operations												
3	Assembly	Assemble with <i>Outer piston</i>												
Remark:														

Table 4, MP - Piston lock stopper

Part:		Piston lock stopper												
DWG no.		SM-Bsc-013												
Rev:		2												
<table border="1"> <thead> <tr> <th>No.</th> <th>Process:</th> <th>Information:</th> </tr> </thead> <tbody> <tr> <td>1</td> <td>Band saw</td> <td>Cut material to length, OD50 length 54mm</td> </tr> <tr> <td>2</td> <td>Machining</td> <td>Lathe. 1opr, cut off at the back of Ø45.</td> </tr> <tr> <td>3</td> <td>Assembly</td> <td>Assemble with connecting parts</td> </tr> </tbody> </table>			No.	Process:	Information:	1	Band saw	Cut material to length, OD50 length 54mm	2	Machining	Lathe. 1opr, cut off at the back of Ø45.	3	Assembly	Assemble with connecting parts
No.	Process:	Information:												
1	Band saw	Cut material to length, OD50 length 54mm												
2	Machining	Lathe. 1opr, cut off at the back of Ø45.												
3	Assembly	Assemble with connecting parts												
Remark:														

Table 5, MP - Spring support

Part:	Spring support													
DWG no.	SM-Bsc-012													
Rev:	1													
<table border="1"> <thead> <tr> <th>No.</th> <th>Process:</th> <th>Information:</th> </tr> </thead> <tbody> <tr> <td>1</td> <td>Slice</td> <td>Slice stl in Prusa slicer</td> </tr> <tr> <td>2</td> <td>Print</td> <td>Apply PLA filament, print</td> </tr> <tr> <td>3</td> <td>Assembly</td> <td>Assemble with Piston spring</td> </tr> </tbody> </table>			No.	Process:	Information:	1	Slice	Slice stl in Prusa slicer	2	Print	Apply PLA filament, print	3	Assembly	Assemble with Piston spring
No.	Process:	Information:												
1	Slice	Slice stl in Prusa slicer												
2	Print	Apply PLA filament, print												
3	Assembly	Assemble with Piston spring												
Remark:														

Table 6, MP - Outer piston tube

Part:	Outer piston tube																
DWG no.	SM-Bsc-011																
Rev:	2																
<table border="1"> <thead> <tr> <th>No.</th> <th>Process:</th> <th>Information:</th> </tr> </thead> <tbody> <tr> <td>1</td> <td>Band saw</td> <td>Cut material, Pipe OD 51, to length 360mm</td> </tr> <tr> <td>2</td> <td>Machining</td> <td>Lathe. 1op. Internal M48x2, chamfer and face off 1-2mm 2op. face off to get 355mm length, drill Ø7 thru.</td> </tr> <tr> <td>3</td> <td>Assembly</td> <td>Several parts to be assembled to this part, remember correct order in assembly.</td> </tr> <tr> <td>4</td> <td>Welding</td> <td>Part 10 to be welded to this part</td> </tr> </tbody> </table>			No.	Process:	Information:	1	Band saw	Cut material, Pipe OD 51, to length 360mm	2	Machining	Lathe. 1op. Internal M48x2, chamfer and face off 1-2mm 2op. face off to get 355mm length, drill Ø7 thru.	3	Assembly	Several parts to be assembled to this part, remember correct order in assembly.	4	Welding	Part 10 to be welded to this part
No.	Process:	Information:															
1	Band saw	Cut material, Pipe OD 51, to length 360mm															
2	Machining	Lathe. 1op. Internal M48x2, chamfer and face off 1-2mm 2op. face off to get 355mm length, drill Ø7 thru.															
3	Assembly	Several parts to be assembled to this part, remember correct order in assembly.															
4	Welding	Part 10 to be welded to this part															
Remark:																	

Table 7, MP - Welded piston plug

Part:	Welded piston plug													
DWG no.	SM-Bsc-004													
Rev:	2													
<table border="1"> <thead> <tr> <th>No.</th> <th>Process:</th> <th>Information:</th> </tr> </thead> <tbody> <tr> <td>1</td> <td>Band saw</td> <td>Cut to length,</td> </tr> <tr> <td>2</td> <td>Machining</td> <td>Mill. Can run this part in either 1 or 2 op. depends on which machine is available. Mill diameter to fit “snug” with <i>Outer piston tube</i>, maybe machine a bigger chamfer onto the side that enters the <i>Outer piston tube</i></td> </tr> <tr> <td>3</td> <td>Assembly</td> <td>Assemble outer piston plug, need welding.</td> </tr> </tbody> </table>			No.	Process:	Information:	1	Band saw	Cut to length,	2	Machining	Mill. Can run this part in either 1 or 2 op. depends on which machine is available. Mill diameter to fit “snug” with <i>Outer piston tube</i> , maybe machine a bigger chamfer onto the side that enters the <i>Outer piston tube</i>	3	Assembly	Assemble outer piston plug, need welding.
No.	Process:	Information:												
1	Band saw	Cut to length,												
2	Machining	Mill. Can run this part in either 1 or 2 op. depends on which machine is available. Mill diameter to fit “snug” with <i>Outer piston tube</i> , maybe machine a bigger chamfer onto the side that enters the <i>Outer piston tube</i>												
3	Assembly	Assemble outer piston plug, need welding.												
Remark:														

Table 8, MP - Clevis pin

Part:	Clevis pin													
DWG no.	SM-Bsc-010													
Rev:	1													
<table border="1"> <thead> <tr> <th>No.</th> <th>Process:</th> <th>Information:</th> </tr> </thead> <tbody> <tr> <td>1</td> <td>Band saw</td> <td>Cut OD20 bar material to correct length, 2pcs.</td> </tr> <tr> <td>2</td> <td>Machining</td> <td>1op. Lathe, turn all relevant dimensions. 2op. Mill. Drill holes</td> </tr> <tr> <td>3</td> <td>Assembly</td> <td>Assembles to <i>Main tube</i>, top and bottom.</td> </tr> </tbody> </table>			No.	Process:	Information:	1	Band saw	Cut OD20 bar material to correct length, 2pcs.	2	Machining	1op. Lathe, turn all relevant dimensions. 2op. Mill. Drill holes	3	Assembly	Assembles to <i>Main tube</i> , top and bottom.
No.	Process:	Information:												
1	Band saw	Cut OD20 bar material to correct length, 2pcs.												
2	Machining	1op. Lathe, turn all relevant dimensions. 2op. Mill. Drill holes												
3	Assembly	Assembles to <i>Main tube</i> , top and bottom.												
Remark:														

Table 9, MP - Main tube

Part:	Main tube													
DWG no.	SM-Bsc-002													
Rev:	1													
<table border="1"> <thead> <tr> <th>No.</th> <th>Process:</th> <th>Information:</th> </tr> </thead> <tbody> <tr> <td>1</td> <td>Band saw</td> <td>Cut pipe OD:60,3 to length: 500mm</td> </tr> <tr> <td>2</td> <td>Machining</td> <td>1op. Mill. Drill holes 2opr. Mill, drill and tap holes</td> </tr> <tr> <td>3</td> <td>Assembly</td> <td>The part is assembled with <i>Liner, Top tube</i> and <i>Outer piston tube</i></td> </tr> </tbody> </table>			No.	Process:	Information:	1	Band saw	Cut pipe OD:60,3 to length: 500mm	2	Machining	1op. Mill. Drill holes 2opr. Mill, drill and tap holes	3	Assembly	The part is assembled with <i>Liner, Top tube</i> and <i>Outer piston tube</i>
No.	Process:	Information:												
1	Band saw	Cut pipe OD:60,3 to length: 500mm												
2	Machining	1op. Mill. Drill holes 2opr. Mill, drill and tap holes												
3	Assembly	The part is assembled with <i>Liner, Top tube</i> and <i>Outer piston tube</i>												
Remark:														

Table 10, MP - Top tube

Part:	Top tube													
DWG no.	SM-Bsc-003													
Rev:	2													
<table border="1"> <thead> <tr> <th>No.</th> <th>Process:</th> <th>Information:</th> </tr> </thead> <tbody> <tr> <td>1</td> <td>Band saw</td> <td>Cut pipe OD51 to length: 450mm</td> </tr> <tr> <td>2</td> <td>Machining</td> <td>1op. Mill. Mill slot 2op. Mill. drill the length adjustment holes</td> </tr> <tr> <td>3</td> <td>Assembly</td> <td>Assemble with D2 threaded cap conn. And Main tube</td> </tr> </tbody> </table>			No.	Process:	Information:	1	Band saw	Cut pipe OD51 to length: 450mm	2	Machining	1op. Mill. Mill slot 2op. Mill. drill the length adjustment holes	3	Assembly	Assemble with D2 threaded cap conn. And Main tube
No.	Process:	Information:												
1	Band saw	Cut pipe OD51 to length: 450mm												
2	Machining	1op. Mill. Mill slot 2op. Mill. drill the length adjustment holes												
3	Assembly	Assemble with D2 threaded cap conn. And Main tube												
Remark: When assembling eith D2 threaded cap conn. Need welding.														

Table 11, MP - D2 threaded cap conn.

Part:	D2 threaded cap conn.													
DWG no.	SM-Bsc-001													
Rev:	3													
<table border="1"> <thead> <tr> <th>No.</th> <th>Process:</th> <th>Information:</th> </tr> </thead> <tbody> <tr> <td>1</td> <td>Band saw</td> <td>Cut material to length 33, OD 65. (S355)</td> </tr> <tr> <td>2</td> <td>Machining</td> <td>Mill 1 or 2 operations depending what machining tools available.</td> </tr> <tr> <td>3</td> <td>Assembling</td> <td>When assembling needs to be welded with counterpart.</td> </tr> </tbody> </table>			No.	Process:	Information:	1	Band saw	Cut material to length 33, OD 65. (S355)	2	Machining	Mill 1 or 2 operations depending what machining tools available.	3	Assembling	When assembling needs to be welded with counterpart.
No.	Process:	Information:												
1	Band saw	Cut material to length 33, OD 65. (S355)												
2	Machining	Mill 1 or 2 operations depending what machining tools available.												
3	Assembling	When assembling needs to be welded with counterpart.												
Remark:														

Table 12, MP - Handle

Part:	Handle																						
DWG no.	SM-Bsc-009																						
Rev:	2																						
<table border="1"> <thead> <tr> <th>No.</th> <th>Process:</th> <th>Information:</th> </tr> </thead> <tbody> <tr> <td>1</td> <td>Slice</td> <td>Slice stl. File in Markforged Metal X slicer</td> </tr> <tr> <td>2</td> <td>Metal print</td> <td>Print part in Markforged Metal X</td> </tr> <tr> <td>3</td> <td>Wash</td> <td>Washing operation</td> </tr> <tr> <td>4</td> <td>Sinter</td> <td>Sinter operation</td> </tr> <tr> <td>5</td> <td>Machining</td> <td>Mill, 1 or 2 op depending on available milling machine</td> </tr> <tr> <td>6</td> <td>Assembly</td> <td>Assemble with Attachment bolt.</td> </tr> </tbody> </table>			No.	Process:	Information:	1	Slice	Slice stl. File in Markforged Metal X slicer	2	Metal print	Print part in Markforged Metal X	3	Wash	Washing operation	4	Sinter	Sinter operation	5	Machining	Mill, 1 or 2 op depending on available milling machine	6	Assembly	Assemble with Attachment bolt.
No.	Process:	Information:																					
1	Slice	Slice stl. File in Markforged Metal X slicer																					
2	Metal print	Print part in Markforged Metal X																					
3	Wash	Washing operation																					
4	Sinter	Sinter operation																					
5	Machining	Mill, 1 or 2 op depending on available milling machine																					
6	Assembly	Assemble with Attachment bolt.																					
Remark:																							

Table 13, MP - C-bracket

Part:	C-bracket																			
DWG no.	SM-Bsc-008																			
Rev:	1																			
<table border="1"> <thead> <tr> <th>No.</th> <th>Process:</th> <th>Information:</th> </tr> </thead> <tbody> <tr> <td>1</td> <td>Band saw</td> <td>Cut material to length 100mm. (square tube 100x100)</td> </tr> <tr> <td>2</td> <td>Machining</td> <td>Mill, only drill and mill holes 2 operations.</td> </tr> <tr> <td>3</td> <td>Band saw</td> <td>Cut off 1 wall to get the c-shape</td> </tr> <tr> <td>4</td> <td>Deburr/Grinding</td> <td>Deburring of sharp edges, grind a slight radius of the edges of where the wall was cut off in the previous machining process.</td> </tr> <tr> <td>6</td> <td>Assembly</td> <td>Assemble with Attachment bolt.</td> </tr> </tbody> </table>			No.	Process:	Information:	1	Band saw	Cut material to length 100mm. (square tube 100x100)	2	Machining	Mill, only drill and mill holes 2 operations.	3	Band saw	Cut off 1 wall to get the c-shape	4	Deburr/Grinding	Deburring of sharp edges, grind a slight radius of the edges of where the wall was cut off in the previous machining process.	6	Assembly	Assemble with Attachment bolt.
No.	Process:	Information:																		
1	Band saw	Cut material to length 100mm. (square tube 100x100)																		
2	Machining	Mill, only drill and mill holes 2 operations.																		
3	Band saw	Cut off 1 wall to get the c-shape																		
4	Deburr/Grinding	Deburring of sharp edges, grind a slight radius of the edges of where the wall was cut off in the previous machining process.																		
6	Assembly	Assemble with Attachment bolt.																		
Remark:																				

Table 14, MP - Attachment body

Part:	Attachment body													
DWG no.	SM-Bsc-006													
Rev:	4													
<table border="1"> <thead> <tr> <th>No.</th> <th>Process:</th> <th>Information:</th> </tr> </thead> <tbody> <tr> <td>1</td> <td>Band saw</td> <td>Cut bar material OD 30 to length 80mm</td> </tr> <tr> <td>2</td> <td>Machining</td> <td>1opr.Lathe, turning of all relevant dimensions 2opr. Mill, 5-axis milling of spheric profiles</td> </tr> <tr> <td>3</td> <td>Assembly</td> <td>Assembles into C-bracket</td> </tr> </tbody> </table>			No.	Process:	Information:	1	Band saw	Cut bar material OD 30 to length 80mm	2	Machining	1opr.Lathe, turning of all relevant dimensions 2opr. Mill, 5-axis milling of spheric profiles	3	Assembly	Assembles into C-bracket
No.	Process:	Information:												
1	Band saw	Cut bar material OD 30 to length 80mm												
2	Machining	1opr.Lathe, turning of all relevant dimensions 2opr. Mill, 5-axis milling of spheric profiles												
3	Assembly	Assembles into C-bracket												
Remark:														

Table 15, MP - Attachment bolt

Part:		Attachment bolt												
DWG no.		SM-Bsc-005												
Rev:		3												
<table border="1"> <thead> <tr> <th>No.</th> <th>Process:</th> <th>Information:</th> </tr> </thead> <tbody> <tr> <td>1</td> <td>Band saw</td> <td>Cut OD 12 bar material to length 100mm</td> </tr> <tr> <td>2</td> <td>Machining</td> <td>1op. Lathe. Use tailstock. Turn all relevant dimensions. 2op. Mill, drill hole, mill flat surface.</td> </tr> <tr> <td>3</td> <td>Assembly</td> <td>Assembles with Handle and setscrew M6</td> </tr> </tbody> </table>			No.	Process:	Information:	1	Band saw	Cut OD 12 bar material to length 100mm	2	Machining	1op. Lathe. Use tailstock. Turn all relevant dimensions. 2op. Mill, drill hole, mill flat surface.	3	Assembly	Assembles with Handle and setscrew M6
No.	Process:	Information:												
1	Band saw	Cut OD 12 bar material to length 100mm												
2	Machining	1op. Lathe. Use tailstock. Turn all relevant dimensions. 2op. Mill, drill hole, mill flat surface.												
3	Assembly	Assembles with Handle and setscrew M6												
Remark:														

Table 16, MP - Liner

Part:		Liner												
DWG no.		SM-Bsc-017												
Rev:		1												
<table border="1"> <thead> <tr> <th>No.</th> <th>Process:</th> <th>Information:</th> </tr> </thead> <tbody> <tr> <td>1</td> <td>Slice</td> <td>Slice stl file in Prusa slicer</td> </tr> <tr> <td>2</td> <td>Print</td> <td>Print two parts in Prusa, use PLA filament</td> </tr> <tr> <td>3</td> <td>Assembly</td> <td>Assemble, one on each end of <i>Main tube</i></td> </tr> </tbody> </table>			No.	Process:	Information:	1	Slice	Slice stl file in Prusa slicer	2	Print	Print two parts in Prusa, use PLA filament	3	Assembly	Assemble, one on each end of <i>Main tube</i>
No.	Process:	Information:												
1	Slice	Slice stl file in Prusa slicer												
2	Print	Print two parts in Prusa, use PLA filament												
3	Assembly	Assemble, one on each end of <i>Main tube</i>												
Remark:														

Table 17, MP - Washer

Part:	Washer													
DWG no.	SM-Bsc-018													
Rev:	1													
<table border="1"> <thead> <tr> <th>No.</th> <th>Process:</th> <th>Information:</th> </tr> </thead> <tbody> <tr> <td>1</td> <td>Slice</td> <td>Slice stl file in Prusa slicer</td> </tr> <tr> <td>2</td> <td>Print</td> <td>Print part in Prusa, use PLA filament</td> </tr> <tr> <td>3</td> <td>Assembly</td> <td>Assembles with <i>Piston lock</i> and <i>Outer piston tube</i></td> </tr> </tbody> </table>			No.	Process:	Information:	1	Slice	Slice stl file in Prusa slicer	2	Print	Print part in Prusa, use PLA filament	3	Assembly	Assembles with <i>Piston lock</i> and <i>Outer piston tube</i>
No.	Process:	Information:												
1	Slice	Slice stl file in Prusa slicer												
2	Print	Print part in Prusa, use PLA filament												
3	Assembly	Assembles with <i>Piston lock</i> and <i>Outer piston tube</i>												
Remark:														

Table 18, MP - Tall nut - M10x1,25

Part:	Tall nut - M10x1.25													
DWG no.	SM-Bsc-019													
Rev:	1													
<table border="1"> <thead> <tr> <th>No.</th> <th>Process:</th> <th>Information:</th> </tr> </thead> <tbody> <tr> <td>1</td> <td>Band Saw</td> <td>Cut bar material OD 30 to length 30mm</td> </tr> <tr> <td>2</td> <td>Machining</td> <td>1 or 2 operations depending on machining tools available. Milling machine.</td> </tr> <tr> <td>3</td> <td>Assembly</td> <td>Assembles with <i>Floating joint</i>.</td> </tr> </tbody> </table>			No.	Process:	Information:	1	Band Saw	Cut bar material OD 30 to length 30mm	2	Machining	1 or 2 operations depending on machining tools available. Milling machine.	3	Assembly	Assembles with <i>Floating joint</i> .
No.	Process:	Information:												
1	Band Saw	Cut bar material OD 30 to length 30mm												
2	Machining	1 or 2 operations depending on machining tools available. Milling machine.												
3	Assembly	Assembles with <i>Floating joint</i> .												
Remark:														

Appendix I, Part list

Part	Drawing no. / Rev.	Qty.
Attachment bolt	SM-Bsc-005 / 3	1
Attachment body	SM-Bsc-006 / 4	1
C-bracket	SM-Bsc-008 / 1	1
Handle	SM-Bsc-009 / 2	1
D2 threaded cap conn.	SM-Bsc-001 / 3	1
Top tube	SM-Bsc-003 / 2	1
Main tube	SM-Bsc-002 / 1	1
Clevis pin	SM-Bsc-010 / 1	2
Welded piston plug	SM-Bsc-004 / 2	1
Outer piston tube	SM-Bsc-011 / 2	1
Spring support	SM-Bsc-012 / 1	2
Piston lock stopper	SM-Bsc-013 / 2	1
Piston lock	SM-Bsc-014 / 2	1
Inner piston tube	SM-Bsc-015 / 2	1
TPU foot	SM-Bsc-016 / 1	1
M10x1,25 Bolt	-	1
Wire	-	2
Wire lock	-	2
Splint/clips	-	2
M6 set screw	-	1
M8 bolt	-	1
M12 flat nut	-	1
Piston spring	-	1
M10x1,25 nut	-	1
Floating joint	-	1
M5 set screw	-	1
Liner	SM-Bsc-017/ 1	2
Washer	SM-Bsc-018/ 1	1
Tall nut - M10x1.25	SM-Bsc-019/ 1	1
Bearing ball Ø3,5		1
Washer M10		1
Coil spring small		1