



FACULTY OF SCIENCE AND TECHNOLOGY BACHELOR THESIS

Study programme / specialisation:

Mechanical Engineering

The spring semester, 2022

Open

Author:
Olai Hagland



Olai Hagland

(signature author)

Course coordinator: Iselin Torland Tjensvold

Supervisor(s): Chandima Ratnayake Mudiyansele, Jan-Tore Jakobsen

Thesis title:

Additive manufacturing and material characterization of H13 tool steel

Credits (ECTS): Johan Andreas Håland Thorikaas, Mats Ingdal

Keywords:

Additive manufacturing
Post production treatments

Pages: 37

Stavanger, 15/06/2022
date/year

Content

| | |
|---|----|
| LIST OF FIGURES..... | 3 |
| LIST OF TABLES | 4 |
| LIST OF FORMULAS..... | 4 |
| LIST OF ABBREVIATIONS | 4 |
| 1. Introduction and motivation | 5 |
| 1.1 Introduction | 5 |
| 1.2 Motivation | 5 |
| 1.2.1 Metal Additive Manufacturing methods | 5 |
| 1.2.2 Markforged Metal X Printer..... | 10 |
| 1.2.3 Markforged H13 tool steel properties | 11 |
| 2. Industrial challenge | 12 |
| 2.1 Why do I want to carry out micro-structural and mechanical testing? | 13 |
| 2.2 How do I solve the problem: Additive manufacturing Parameters? | 13 |
| 3. Methodology | 14 |
| 3.1 Experimental approach..... | 14 |
| 3.1.1 Metal AM Process | 15 |
| 3.1.2 Tensile testing | 15 |
| 3.1.3 Specimen preparation for Hardness and microscopy | 19 |
| 4. Results | 20 |
| 4.1 Tension | 20 |
| 4.1.1 Normal as-sintered specimens..... | 20 |
| 4.1.2 Heat treated specimens..... | 20 |
| 4.1.3 Machined as-sintered specimens | 21 |
| 4.1.4 Final data | 21 |
| 4.2 Hardness | 21 |
| 4.2.1 Normal..... | 21 |
| 4.2.2 Heat treated | 22 |
| 4.3 Microscopy | 23 |
| 4.3.1 Normal..... | 23 |
| 4.3.2 Heat treated | 26 |
| 5. Analysis and discussion | 28 |
| 5.1 Tension | 28 |
| 5.1.1 Breakages on the specimens..... | 28 |
| 5.1.2 Differences | 30 |

| | |
|---------------------------------------|----|
| 5.1.3 Problems during testing..... | 31 |
| 5.1.4 Problems during Machining | 32 |
| 5.1.5 Printing limitations | 32 |
| 5.2 Hardness | 33 |
| 5.3 Microscopy | 34 |
| | 35 |
| 6. Conclusion..... | 35 |
| 7. References | 36 |

LIST OF FIGURES

| | |
|---|----|
| Figure 1: AM Process..... | 6 |
| Figure 2: Metal AM technology overview | 7 |
| Figure 3: Friction energy deposition illustration..... | 7 |
| Figure 4: Filament material extrusion illustration..... | 8 |
| Figure 5: illustration of LB-PBF | 9 |
| Figure 6: Illustration of DED | 9 |
| Figure 7: H13 printed Tensile stress-strain chart | 12 |
| Figure 8: Example from previous prints | 14 |
| Figure 9: Illustration of test amounts | 14 |
| Figure 10: Example of how the specimens will be printed | 15 |
| Figure 11 : Example of engineering stress-strain curve..... | 17 |
| Figure 12: Dimensions of tensile test specimen made from ASTM E8..... | 18 |
| Figure 13: Illustration of building direction | 19 |
| Figure 14: Illustration of specimen cut for microscopy and hardness | 19 |
| Figure 15: As-sintered Normal tensile stress/strain graph | 20 |
| Figure 16: Heat treated tensile stress/strain graph | 20 |
| Figure 17: As-sintered Machined tensile stress-strain graph | 21 |
| Figure 18: Microstructural overview Top As-sinterd | 23 |
| Figure 19: Microstructural overview Side As-sinterd..... | 24 |
| Figure 20: Microstructural overview Middle As-sinterd | 25 |
| Figure 21: Microstructural overview Top H-T | 26 |
| Figure 22: Microstructural overview Side H-T..... | 27 |
| Figure 23: Microstructural overview Middle H-T | 28 |
| Figure 24: Illustration on impurities in specimen under load | 29 |
| Figure 25: Preview of sliced specimen layer 152-161/177 | 29 |
| Figure 26: Impurities in the printed specimen | 29 |
| Figure 27: Impurities in arc at end of gauge section | 30 |
| Figure 28: Impurities in middle of gauge section | 30 |
| Figure 29: overview, breakage on specimens | 30 |
| Figure 30: Data summary tension test..... | 30 |
| Figure 31: Evidence of gliding in tension test machine | 31 |
| Figure 32: Specimen during machining in CNC..... | 32 |
| Figure 33: Failed vertical specimens..... | 32 |
| Figure 34: Fault message on sinter..... | 33 |
| Figure 35: Top H-T | 34 |
| Figure 36: Side H-T..... | 34 |

| | |
|--|----|
| Figure 37: Middle H-T | 34 |
| Figure 38: round seam transission..... | 34 |
| Figure 39: zoomed side view. | 35 |

LIST OF TABLES

| | |
|--|----|
| Table 1: H13 tool steel filament contents..... | 11 |
| Table 2: H13 tool steel printed properties | 12 |
| Table 3: Tension test data overview..... | 21 |
| Table 4: Hardness data as-sintered in HV | 22 |
| Table 5: Hardness data heat-treated in HV | 22 |
| Table 6: Comparing material properties..... | 31 |

LIST OF FORMULAS

| | |
|---|----|
| Equation 1: Engineering strain [mm/mm]..... | 16 |
| Equation 2: True strain [mm/mm]..... | 16 |
| Equation 3: Engineering stress [N/mm ²] | 16 |
| Equation 4: True stress [N/mm ²] | 16 |
| Equation 5: Young's modulus | 17 |
| Equation 6: Engineering strain at fracture..... | 18 |
| Equation 7: Reduction of area at fracture..... | 18 |

LIST OF ABBREVIATIONS

| | |
|------|--|
| 3D | 3 Dimensional |
| AM | Additive Manufacturing |
| ASTM | American Society for Testing and Materials |
| ADAM | Atomic Diffusion Additive Manufacturing |
| BMD | Bound Metal Deposition |
| CAD | Computer Aided Design |
| CNC | Computerized Numerical Control |
| DED | Direct Energy Deposition |
| FDM | Fused Deposition Material |
| FME | Filament Material Extrusion |
| MIG | Metal Inert Gas |
| SLS | Selective Laser Sintering |
| TIG | Tungsten Inert Gas |
| PME | Pellet Material Extrusion |
| HV | Vickers Hardness |
| HRC | Rockwell Scale of Hardness |

| | |
|--------|------------------------------|
| UED | Ultrasonic Energy Deposition |
| LB-PBF | Laser Beam Powder Bed Fusion |

1. Introduction and motivation

1.1 Introduction

Today's modern society is highly impacted by high production costs, high shipping costs, shortage on raw materials and an economy impacted by two years of a pandemic. These dilemmas make companies search for different production methods to implement in their production chain in order to get a stronger and more versatile production chain.

The AM sector has for all the years pre-covid-19 had an exponential growth in revenue, as well as in their technology. Since covid-19 started in 2020, the sector has had a negative revenue. But it's predicted to recover within the decade.

The AM technologies are improving rapidly and is expected to be a viable option for consumers in the near future. In fact, the existing AM technologies are already well implemented in industries like aviation, automotive and healthcare. And since the start of commercial AM, it's been used for innovation and prototyping in most industries. But it is expected to expand quickly in the industry in the years to come, especially in the oil and gas industry.

1.2 Motivation

In this thesis I want to find out how different post-production treatments of metal AM can be used to make a parts and tools more reliable and attractive. I will be using University of Stavanger's metal printer to print test specimens in H13 tool steel. In addition to testing the post production methods, I will also have a look at the reliability of the metal AM technology and its specifications.

1.2.1 Metal Additive Manufacturing methods

Metal Additive Manufacturing, also known as metal 3D-printing, is a process which prints 3D models layer by layer. The AM technology is rapidly evolving day by day. And although metal AM technology has been available for some time now, there has never before been so many different possibilities to derive metal AM.

In a new study published by AMPOWER, they state that over 18 different metal AM processes are known as of March 2022.

"Metal 3D printing is more diverse today than ever. More so today is the principle that the application determines the technology" (Ampower insights , 2022).

In the chart shown in figure 2 you can see an overview of the different metal AM technologies available on the market. It also shows if they're sinter-based or direct printed. As well as the companies that supply the different metal AM technologies.

Metal additive manufacturing offers unrivalled design freedom while being able to manufacture with a wide range of materials. Complex components that were not possible to produce just a few years ago, can now be made with high standards in a wide range of materials. *"No longer solely a prototyping technology, additive manufacturing is now being used for the production of series components for the most demanding applications"* (Metal AM, 2022).

Although there is a lot of different metal AM processes, they are all based on the same baseline technology. AM is a process where a CAD drawing is first "sliced" into layers of a specific height. Then the printer will build the 3D model layer by layer upwards like shown in figure 1.

In metal AM, the difference between the methods is how the layers are bonded together. Most methods use metal powder which gets melted together to the printed part. The different technologies dictate how the powder gets melted to the part. In addition to the powder methods, there are also several alternative methods available. Some of these are similar to MIG welding with a metal wire feed, some are friction welding, and some are just like normal plastic AM with heated extrusion where the metal powder is embedded in the filament.

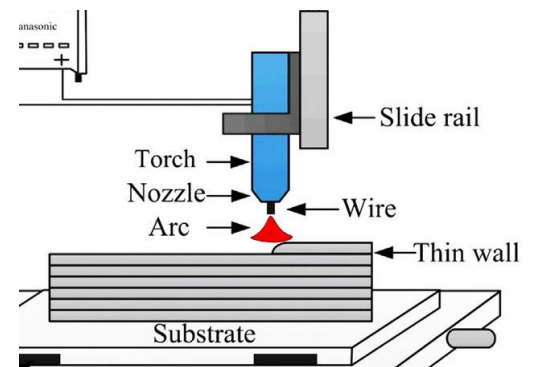

Figure 1: AM Process

Metal Additive Manufacturing technology landscape



Figure 2: Metal AM technology overview

The metal AM technologies:

1.2.1.1 Ultrasonic Energy Deposition

Technology used to improve DED. The goal is to improve the “as built” quality and mechanical performance for the printed metal parts. Although this technology has attracted little attention due to its complexity and the emphasized need to understand the thermodynamics in the melt pool of the DED printing method. With UED it’s possible to control the melt pool size and peak temperature, which makes it possible to have better control over porosity, hardness and grain refinement of the finished metal parts.

1.2.1.2 Friction Energy Deposition

AM process based on friction stir welding and friction stir processing technology. Metal sheets gets added for each layer on top of the once already melted together. It uses friction formed by the rotating tool to heat the newly added sheet, so it adheres to the sheets underneath. The process is showed in figure3

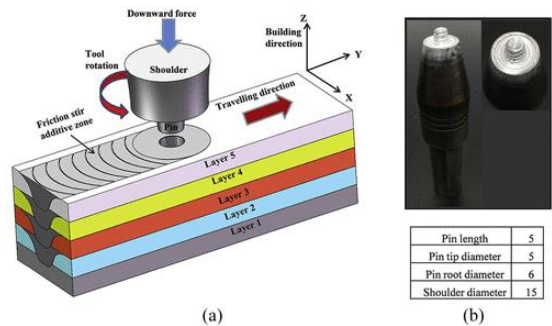

Figure 3: Friction energy deposition illustration

1.2.1.3 Nanoparticle Jetting

NPJ is a material jetting technology. The process is based on jetting a liquid that contains nanoparticles of metal material in suspension to build up the part. It's built in a hot chamber which allows the liquid to evaporate upon jetting. This process requires post-printing washing and sintering.

1.2.1.4 Filament Material Extrusion

This process is similar to the popular plastic based FDM process. But in this process, there are metal particles embedded in the filament. The filament is then melted through a nozzle to build up the part. This process will be future explained later in this report.

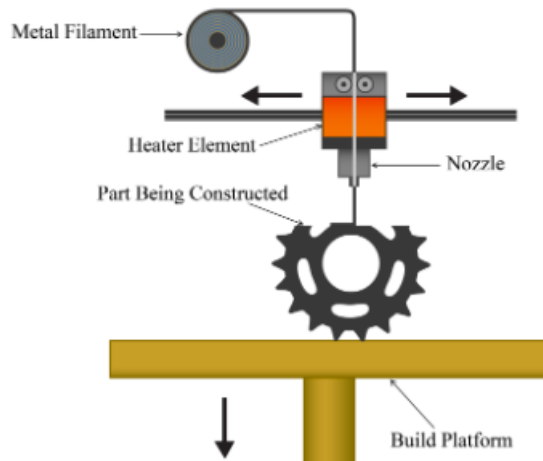

Figure 4: Filament material extrusion illustration

1.2.1.5 Pellet Material Extrusion

Pellet based material extrusion is a modification of FME. The only difference is the used feedstock. PME is usually used for higher volume output than FME, in fact from 10x-100x the more. In addition to the higher speeds, the pellet feedstock is a fraction of the filament cost.

1.2.1.6 Metal Lithography

Lithography based metal manufacturing is a AM technology for creating advanced metal models. Using the principle of photopolymerization, the metal powder is homogeneously dispersed in a light sensitive resin and gets polymerized by exposure with light.

1.2.1.7 Binder Jetting

Binder jetting uses metal powder together with a liquid adhesive in order to solidify the powder. The metal powder is laid down layer by layer, and for each layer there is applied a liquid binder material. This method of binding the metal powder together does not always

achieve great material properties for structural parts. The speed of the printing and post-processing is usually quite quick.

1.2.1.8 Metal Selective Laser Sintering

Selective laser sintering is one of the most mature AM technologies on the market. SLS is the most common technology due to superior surface quality and material properties. A powder compound made of polymer and metal powder is used to print the parts. The polymer is then removed in the sintering process there the part gets melted together.

1.2.1.9 Electron Beam Powder Bed Fusion

Electron beam powder bed fusion is an AM technology based on melting metal powder by exposing it to a beam of electrons. After adding a thin layer of metal powder and preheating it, the electron beam is deflected by an electromagnetic field which fuses the needed part of the layer together. This is then repeated by adding a new layer of metal powder.

1.2.1.10 Laser Beam Powder Bed Fusion

Also known as selective laser melting, is the most known metal AM technology. It's based on melting a powder feedstock which is pre-dried on the build plate in predefined layer thicknesses. This powder is then melted together by a laser beam.

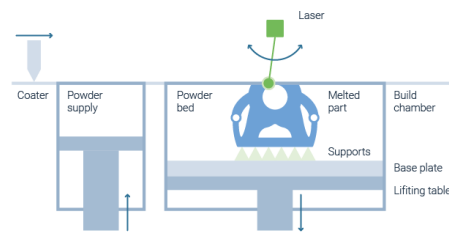

Figure 5: illustration of LB-PBF

1.2.1.11 Powder Laser Energy Deposition

DED – Metal powder is fed into a laser generated melt pool. An easy principle which can be used to print new parts, or to repair damaged parts or cracks. The process is well explained in figure 6

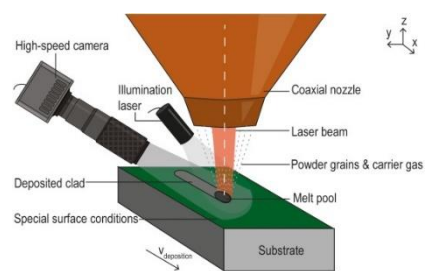

Figure 6: Illustration of DED

1.2.1.12 Coldspray

Coldspray is a low temperature, solid state consolidation technique and can be used to process temperature sensitive materials such as nanomaterials and amorphous materials. This is unlike the powder consolidation techniques such as pressing and sintering.

1.2.1.13 Wire Electric Arc Energy Deposition

This is simply CNC MIG welding where a wire feed comes out through the middle of the tool. The melting electricity comes directly in the metal wire. Often there is an anti-flammable gas like Argon.

1.2.1.14 Wire Laser Beam Energy Deposition

This is based on TIG welding where there is a metal rod feed (which in this case is a wire feed) and then a directed laser which replaces a tungsten in TIG welding to make a welding pool for the metal to melt together.

1.2.1.15 Liquid Metal Printing

Liquid metal printing uses droplets of molten metal that are deposited on a base plate to directly build the part. This is a new technology with a lot of future potential.

1.2.2 Markforged Metal X Printer

The University of Stavanger has invested in a metal 3D printer produced by the company Markforged. This is a complete system delivered by Markforged which includes the printer, washer/dryer and a sinter.

The system is optimized for ease of use for the user. With this system, the user has little room for adjustment on the printing parameters. The user must just simply operate by the instructions from Markforged.

The Markforged Metal X is a filament material extrusion system called Atomic Diffusion Additive Manufacturing (ADAM). Essentially this is just metal powder embedded inside plastic filament. As in most AM technologies, the parts are built up layer by layer. Due to shrinkage later in its sintering process, the parts will be printed at a certain percentage bigger than its final size to compensate. Which allows it to be able to print a wide variety of material including stainless steel, copper, Inconel and tool steels.

With the Filament extrusion method, it's quite a lot of steps that the user must accomplish in order to get a successful print. Although the system gives a lot of guiding and warnings to make sure you do the required steps, there is still room for user error. Faults by the user can lead to insufficient prints or even damaged machinery. Examples of this could be not washing the part properly, not drying the part properly, not cleaning the brushes, putting in the wrong material or putting on the wrong sinter program.

The system is a cloud-based system called Eiger. All the parts are uploaded, sliced and exported on the webpage. Apart from the print material and bed preparations, everything is controlled through the webpage.

1.2.2.1 Advantages of Metal X printer

- Easy to go from a 3d object to a physical printed part when the steps are followed correctly.
- Easy to handle and install the raw material, the user is well guided through this process
- Cheap to buy (compared to other AM systems)
- Allows for printing complex parts which gives more flexibility in the design process.
- Wide range of materials available

1.2.2.2 Disadvantages of Metal X printer

- Limited parameter adjustments
- Limited print size by the sinter furnace, both height and width is limited
- Still quite costly for small prints (primarily furnace gas and material costs)
- Much waste material due to parts needing rafts (base for the part).

1.2.3 Markforged H13 tool steel properties

These are the material properties of Markforged H13 tool steel shown in table 1, 2 and figure 7. The data is collected from their datasheet online. All the data comes from standardized tests done by Markforged.

| Composition | Amount |
|-------------|-----------|
| Chromium | 4.7-5.5% |
| Molybdenum | 1.3-1.7% |
| Silicon | 0.8-1.2% |
| Vanadium | 0.8-1.2% |
| Carbon | 0.3-0.45% |
| Manganese | 0.2-0.5% |
| Phosphorous | 0.03% max |
| Sulfur | 0.03% max |
| Iron | bal |

Table 1: H13 tool steel filament contents

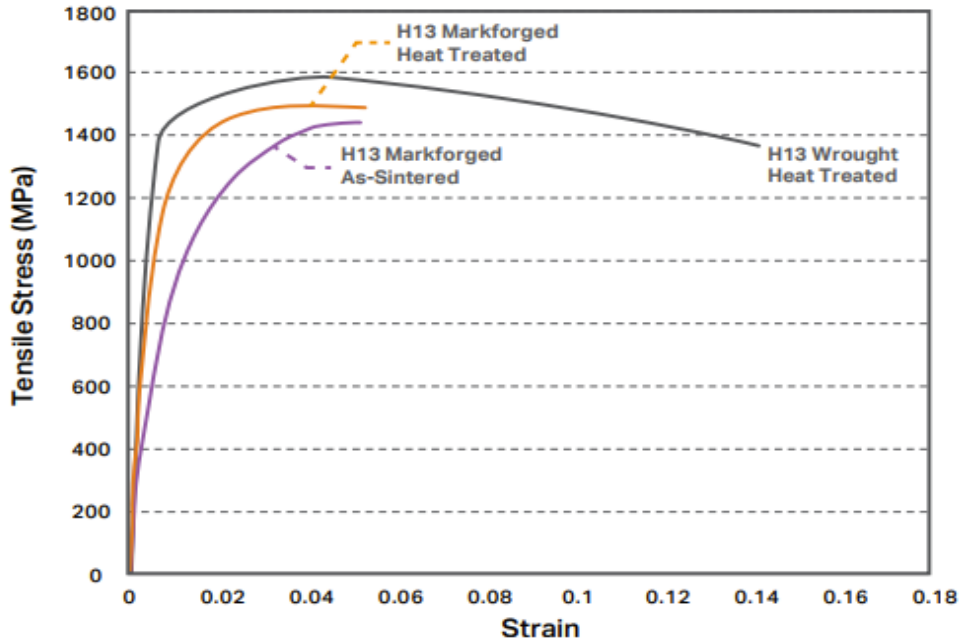

Figure 7: H13 printed Tensile stress-strain chart

| Typical Mechanical Properties | Standard | Markforged As-Sintered | Markforged Heat Treated | Wrought Heat Treated* |
|-------------------------------|-----------|------------------------|-------------------------|-----------------------|
| Ultimate Tensile Strength | ASTM E8 | 1420 MPa | 1500 MPa | 1580 MPa |
| 0.2% Yield Strength | ASTM E8 | 800 MPa | 1250 MPa | 1360 MPa |
| Elongation at Break | ASTM E8 | 5% | 5% | 14% |
| Hardness | ASTM E18 | 40 HRC | 45 HRC | 46 HRC |
| Relative Density | ASTM B923 | 94.5% | 94.5% | 100% |

Table 2: H13 tool steel printed properties

2. Industrial challenge

While design flexibility, material efficiency and viable low volume production are some of the arguments used to justify AM. There will still be challenges with using AM industrially. Some of the challenges can be listed as follows:

- Slow production speeds: It takes the Metal X printer 100h to print a part (including washing and sintering) that takes a CNC operator 4h to make. Although the printer can work 24/7, its hard to justify this time for anything but prototyping or production of complex parts which is not possible to machine with CNC.
- Size limitations: although CNC machines also have size limitations, its generally more limited in the AM sector. While there is possible to print bigger objects with

AM than you are able to with a CNC, it's generally way too expensive for general consumer-based markets.

- Material limitations: While there is a wide variety of materials already available for AM. There is still a long way to go on covering all the materials.
- Material development and inconsistencies in material properties: Defects in printed metal parts is a wide problem in the AM industry. As the technology evolves quickly, we can expect these problems to be less of a concern over the future years. How big of a problem it is now differs quite a bit depending on which printing technology it is.
- Manual post-processing
- Limited capabilities in data preparation and design
- Part-to-part variation
- Lack of industry-wide standards
- Lack of understanding and expertise in AM
- Having to make the initial investment: This is an industry wide dilemma as the metal AM systems can be quite costly. Depending on the size of the company, this can easily be a limiting factor for the market as of now.
- Disjoined AM ecosystem
- A lack of digital infrastructure

2.1 Why do I want to carry out micro-structural and mechanical testing?

As of now, the AM process is mostly used for prototyping (especially ADAM). With mechanical and micro-structural testing, I would like to investigate how different post printing treatments can achieve a more attractive result for use in daily production.

In addition to testing different treatments of the printed specimens, I am also going to have a look at the test data and compare it to the datasheets for the ordered material as well as simply raw material (not printed)

2.2 How do I solve the problem: Additive manufacturing Parameters?

As stated earlier, the Metal X printer has a limited amount of adjustability on the printing parameters. Being a web-based slicer program, there often is less adjustability than if there would have been a software based program. As of now, there is not much we can do, rather than asking Markforged to open up for more flexibility.

With the Metal X printer and ADAM print method, we can predict defects in our print specimens as shown in figure 8 (picture from an earlier tests). Although these pictures are from another material, the printing method should be about the same.

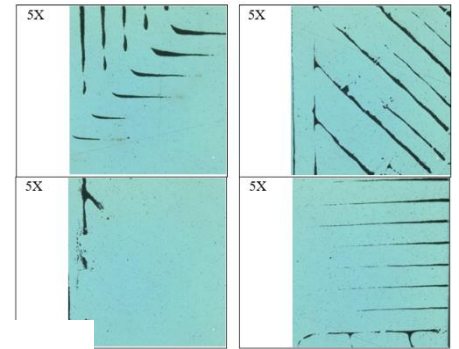
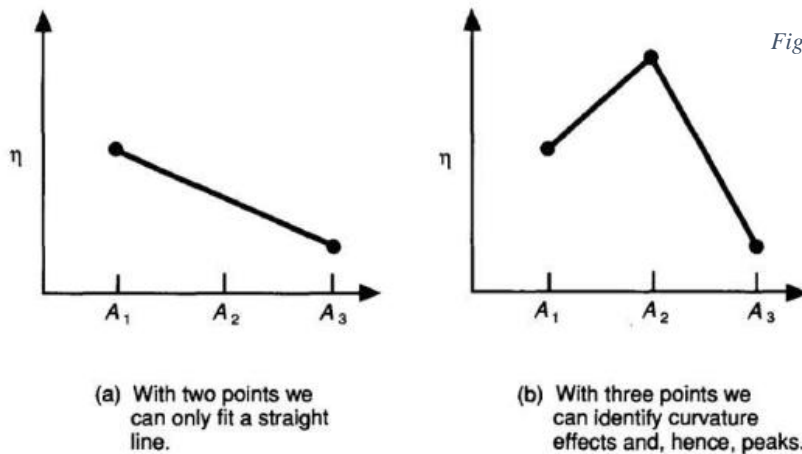

Figure 8: Example from previous prints

As we can see in figure 8, there are clearly some defects in the printed specimens. The Black lines we see is cavities in between the beads laid down by the printer. It's a sign of an unsuccessful



adhesion process.

The theory to solve this problem is quite simple. If the nozzle temperature while printing is too low, the flowrate is too low or if the layer height is too big, we will get insufficient adhesion. It might be only one of the cases, two or all three.

If we were to lower the layer height, the outcoming bead would be pressed more flat instead of round (this requires enough filament flow). This is possible to achieve with bigger nozzle and higher filament flow as well. In theory we would like the filament to be added as a square in order to limit cavities.

If the temperature is too low, there would be insufficient adhesion. Increasing the temperature would allow the new filament to melt better in with the already printed filament.

Assuming that the temperature is high enough, it also possible to just increase the filament flow so that the filament gets pushed in to all the cavities. Although this would make e less precise part considering the dimensions and surface finish.

3. Methodology

3.1 Experimental approach

For each tested condition or treatment of a specimen, we would like to have at least three tests in order to get good coverage on a test result. We are interested in nonlinearity in the

Figure 9: Illustration of test amounts

test results. With only two measurements, we can only predict a straight line. But with three or more measurements we can predict a curvature and predict an average as well as the delta variety.

Figure 9 shows an example of potential critical data we could miss with only two measurements. Furthermore, with only two measurements we would not be able to predict if the data should continue down or if it would go up.

3.1.1 Metal AM Process

After making the 3D model in CAD in the dimensions written in the ASTM-E8/E8M, we can export the model as an STL file ready to import into the slicing program on the Eiger website. When the part is sliced on the website, we prepped the printer by installing new brushes, new filament material and new buildplate sheet. With all that done, we started printing the test specimens.

The specimen will then be printed layer by layer like showed in figure 10

When the specimens where done printing, they got weighted and put in to the washer in order to start de binding the building material and make it ready for sintering.

When washed and dried, it got weighted again to make sure the correct amount of binding material had been removed from the part. If this is not done properly, the sintering machine will get clogged and malfunction.

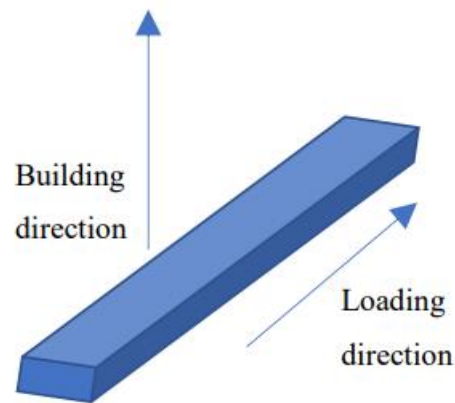

Figure 10: Example of how the specimens will be printed

If the right weight is achieved, it was put in the sintering machine where it will melt the rest of the binding material away until its just powder, and then melt the metal powder together. This is the reason for the shrinkage.

3.1.2 Tensile testing:

Tensile test is the most common method to determine the properties of a metallic material. It's a standardized test which is easy to carry out. The test can be accomplished fast, and easily give us accurate properties for the material under tension loading.

The test consists of mounting the test specimen in the elongation machine and apply pulling force until the specimen fractures. When the axial load increases, the elongation of the gauge section of the specimen is recorded against the applied force.

3.1.2.1 Theoretical:

From the data recorded during the test, an engineering stress-strain graph diagram is made. The engineering strain “e” is used in the graph, and it is the calculated mm elongation per mm (mm/mm). It can be calculated as shown in Equation 1:

$$\text{Engineering strain } e = \frac{\Delta L}{L_0} = \frac{L - L_0}{L_0}$$

Equation 1: Engineering strain [mm/mm]

Where delta L is the change in gauge length, and L0 is the initial gauge length before applying tension load.

We can also express strain as true strain ϵ , which is based on the gauge length of the specimen as the test is in progress divided on the original length of the gauge section. The formula can be derived as shown in equation 2:

$$\text{True strain } \epsilon = \ln\left(\frac{L}{L_0}\right)$$

Equation 2: True strain [mm/mm]

Engineering stress “s”, is calculated by dividing the force measurements at anytime by the initial cross-sectional area of the gauge section of the specimen. It can be calculated by using the formula shown in equation 3:

$$\text{Engineering stress } s = \frac{F}{A_0}$$

Equation 3: Engineering stress [N/mm²]

Where F is the applied tensile force, and A0 is the initial cross-sectional area of the gauge section.

Stress can also be expressed as true stress “ σ ”, which the tension force at any time during the test divided by the initial cross-sectional area of the gauge section. It can be derived like in equation 4:

$$\text{True stress } \sigma = \left(\frac{F}{A}\right)$$

Equation 4: True stress [N/mm²]

When the data from a tensile test is converted to engineering stress and strain, an engineering stress-strain curve can look like shown in figure 11:

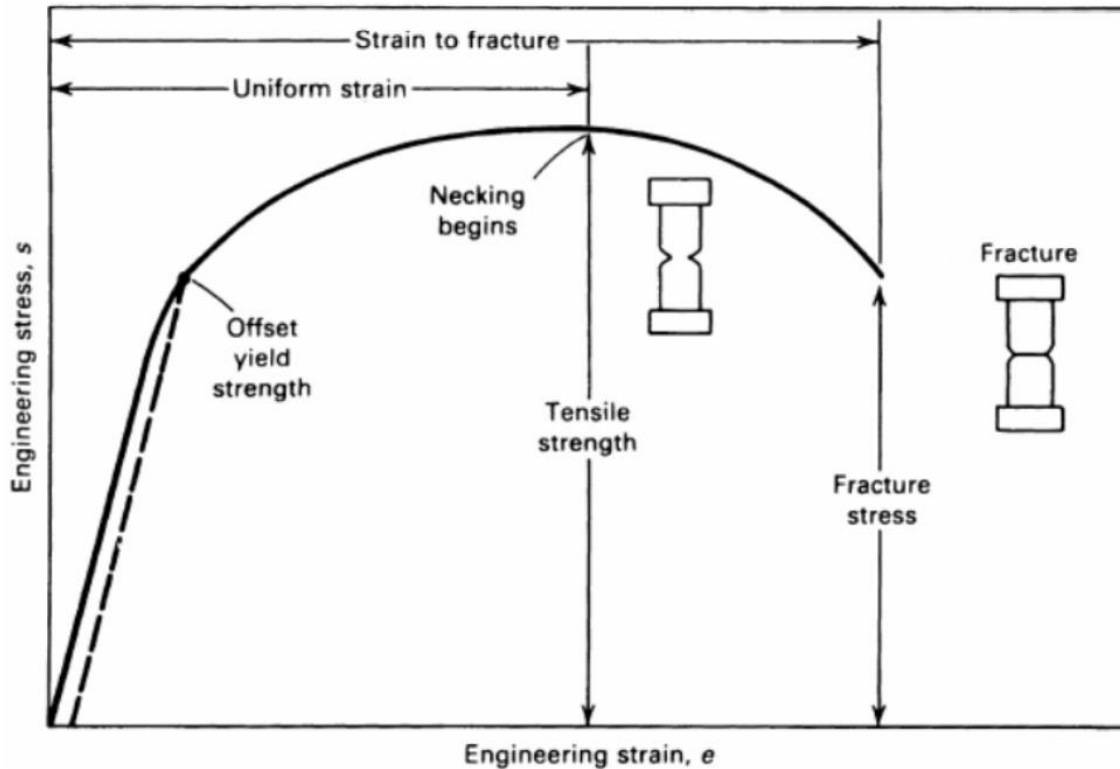

Figure 11 : Example of engineering stress-strain curve

In the initial part of the tensile test which is the “elastic region”, the stress-strain curve is linear for the most part. This linear part of the curve represents the modulus of elasticity (or Young’s modulus), “ E ”. The modulus of elasticity tells us the materials resistance to elastic deformation (deformation without permanent deformation). A measure of stiffness of a material. The modulus of elasticity can be derived like in equation 5:

$$\text{Young's modulus} \quad E = \frac{s}{e}$$

Equation 5: Young's modulus

In the elastic region, the material doesn’t permanently deformed. So when the load is removed, it will come back to its initial shape.

Yield strength is the magnitude of stress corresponding to permanent deformation. This means that if you remove the load, the specimen will be permanently deformed. Its called the elastic limit, and can be hard to define on metals. Therefore, according to ASTM E8, we can draw a linear line parallel to the stress-strain curve at 0.2% of the plastic strain. Example of this is shown in figure 11.

The ductility obtained from the tension test is the engineering strain at fracture, and the reduction in area at fracture. These properties are expressed as a percentage:

$$\%e_f = \frac{L_f - L_0}{L_0} * 100$$

Equation 6: Engineering strain at fracture

$$\%RA = \frac{A_0 - A_f}{A_0} * 100$$

Equation 7: Reduction of area at fracture

Ultimate tensile strength is the highest load the specimen sustains during the test before fracture.

3.1.2.2 Test Parameters

For the tensile test, I will be following the ASTM E8/E8M standard. This will decide the specimen dimensions as well as its testing speed (how fast the load will increase on the specimen).

The dimensions for the final test specimen are shown in figure 12.

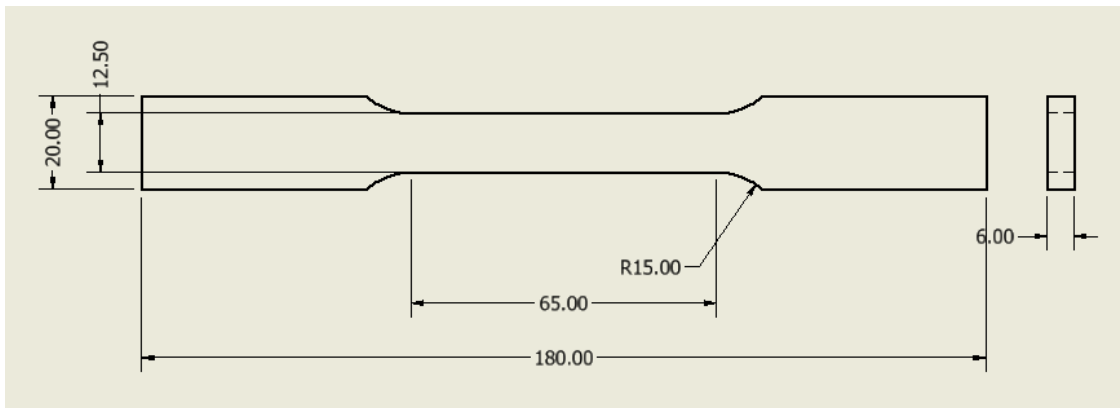

Figure 12: Dimensions of tensile test specimen made from ASTM E8

3.1.3 Specimen preparation for Hardness and microscopy

Test specimens for hardness and microscopy are printed in same orientation as figure 13. For the hardness and microscopy, there are only need for as-sintered and heat-treated specimens as they both will be machined and polished.

The printed specimens are then cut into smaller pieces to be able to test different print-force directions and parts of the specimen. The Plan is to test the top, side and middle of the specimen as shown in Figure 14. The orange and yellow test surfaces are on the top of section 1 and 3, while the green is on the right side of section 2.

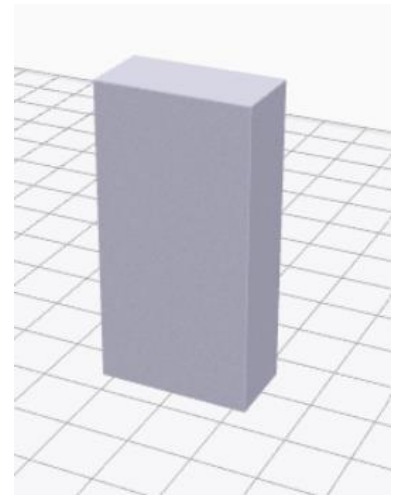

Figure 13: Illustration of building direction

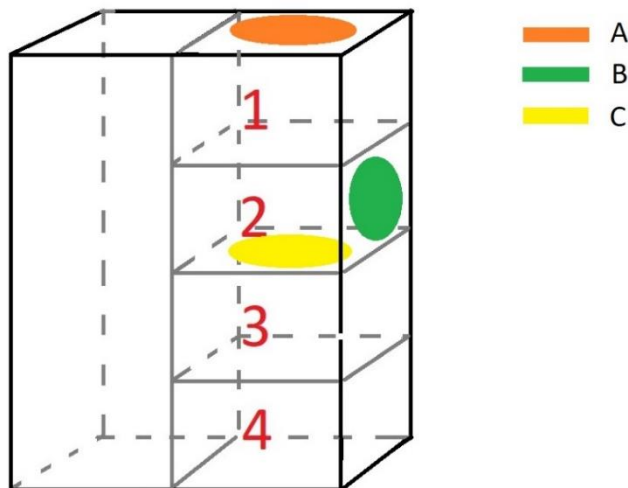

Figure 14: Illustration of specimen cut for microscopy and hardness

The specimens were then future prepped using Struers method D. In addition to this, the specimens were put 10 minutes in ultrasonic ethanol cleaner in order to clean out all the debris from the cavities in the specimen.

4. Results

4.1 Tension

4.1.1 Normal as-sintered specimens

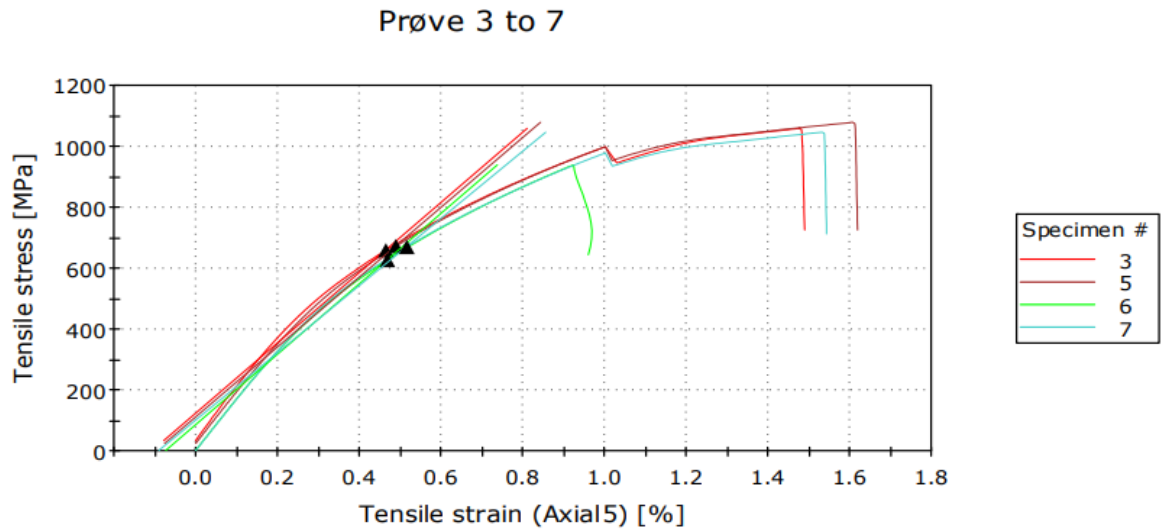

Figure 15: As-sintered Normal tensile stress/strain graph

4.1.2 Heat treated specimens

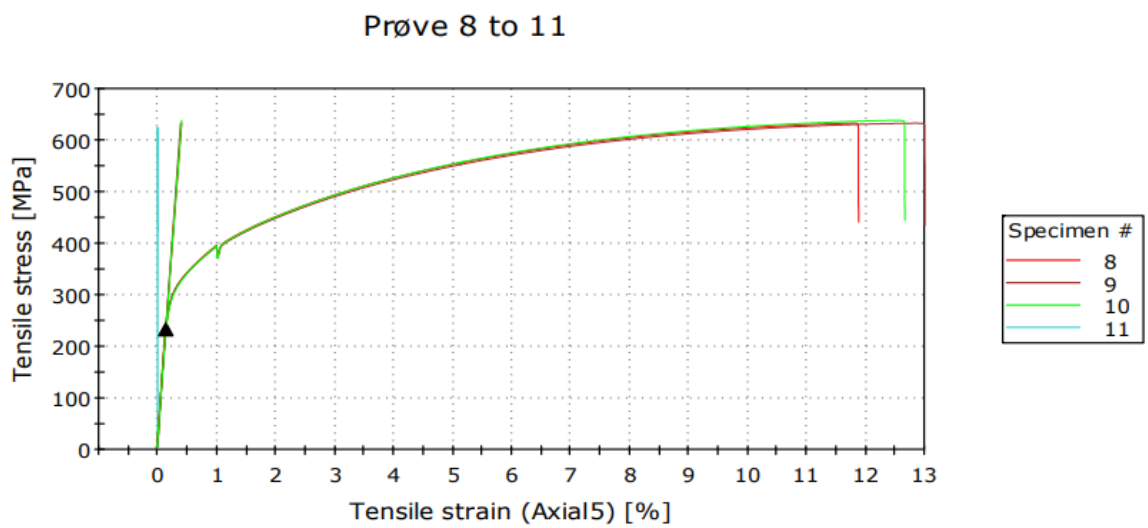

Figure 16: Heat treated tensile stress/strain graph

4.1.3 Machined as-sintered specimens

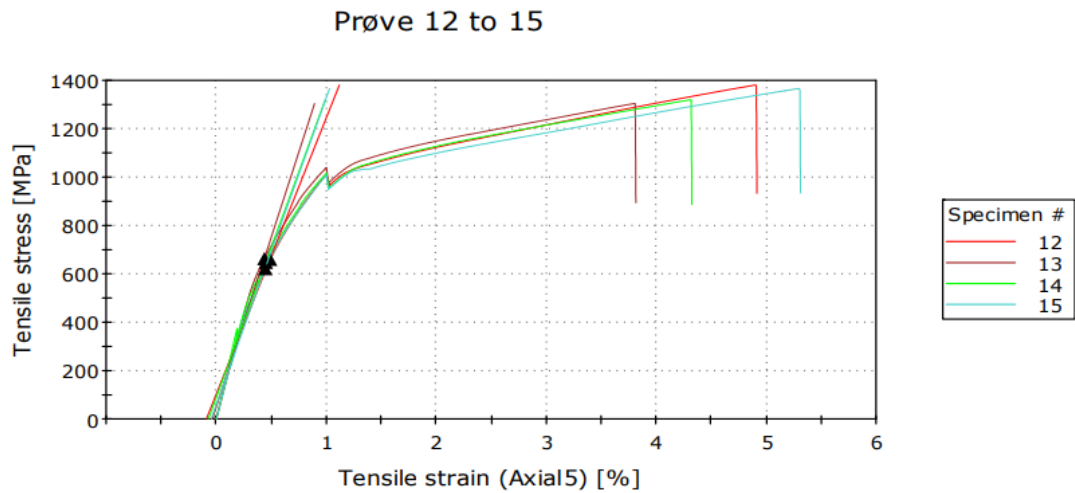

Figure 17: As-sintered Machined tensile stress-strain graph

4.1.4 Final data

| | Navn | E [GPa] | ReH [MPa] | ReL [MPa] | Rp0.2 [MPa] | Rm [MPa] | Forlengelse [%] | Rm | Forlengelse brudd [%] |
|----|-------------|---------|-----------|-----------|-------------|----------|-----------------|----|-----------------------|
| 3 | Normal 1 | 114.9 | ----- | ----- | 660.3 | 1059 | 0.55148 | | 0.55148 |
| 5 | Normal 2 | 114.3 | ----- | ----- | 673.7 | 1079 | 0.66109 | | 0.66109 |
| 6 | Normal 3 | 115.2 | ----- | ----- | 628.5 | 939.4 | 0.10709 | | 0.10709 |
| 7 | Normal 4 | 110.1 | ----- | ----- | 671.4 | 1047 | 0.57910 | | 0.57910 |
| 8 | Herdet 1 | 148.4 | ----- | ----- | 236.3 | 632.7 | 11.24 | | 11.40 |
| 9 | Herdet 2 | 156.3 | ----- | ----- | 236.2 | 632.9 | 12.36 | | 12.54 |
| 10 | Herdet 3 | 150.8 | ----- | ----- | 234.8 | 638.4 | 12.02 | | 12.18 |
| 11 | Herdet 4 | ----- | ----- | ----- | ----- | 625.9 | 0.00050 | | 0.00050 |
| 12 | Maskinert 1 | 113.8 | 967.6 | ----- | 663.4 | 1370 | 3.554 | | 3.678 |
| 13 | Maskinert 2 | 139.7 | ----- | ----- | 666.9 | 1305 | 2.866 | | 2.866 |
| 14 | maskinert 3 | 123.9 | 970.2 | ----- | 650.8 | 1310 | 3.117 | | 3.242 |
| 15 | Maskinert 4 | 126.6 | 957.5 | ----- | 625.6 | 1356 | 4.076 | | 4.209 |

Table 3: Tension test data overview

4.2 Hardness

The hardness was measured at 9 points on each of the 3 as-sintered and 3 heat treated specimens from the different assigned parts of the printed specimens. Defects and abnormalities during the test are well documented.

Stuers method D was used to prep the specimens for the test.

The tests were done with 30kg for 10 seconds.

4.2.1 Normal

| \ Specimen | A | B | C |
|--------------|-------|-------|-------|
| Test nr. \ 1 | 380.3 | 389.0 | 430.0 |
| 2 | 434.3 | 386.9 | 429.7 |
| 3 | 413.3 | 372.1 | 457.3 |
| 4 | 359.5 | 393.4 | 450.1 |
| 5 | 413.5 | 391.1 | 425.7 |
| 6 | 413.7 | 380.3 | 367.7 |
| 7 | 459.9 | 375.4 | 361.2 |

| | | | |
|----------------|--------------|--------------|--------------|
| 8 | 457.8 | 395.4 | 453.9 |
| 9 | 336.4 | 383.1 | 438.9 |
| Average | 407.6 | 385.2 | 423.9 |

Table 4: Hardness data as-sintered in HV

4.2.2 Heat treated

| \ Specimen | A | B | C |
|-------------------|--------------|--------------|--------------|
| Test nr. \ | | | |
| 1 | 141.2 | 137.0 | 168.3 |
| 2 | 157.1 | 154.1 | 174.9 |
| 3 | 131.7 | 149.8 | 158.3 |
| 4 | 133.3 | 153.5 | 154.6 |
| 5 | 154.8 | 155.6 | 172.3 |
| 6 | 150.4 | 140.0 | 161.5 |
| 7 | 139.2 | 134.6 | 160.8 |
| 8 | 142.7 | 153.6 | 174.6 |
| 9 | 135.1 | 148.7 | 151.6 |
| Average | 142.8 | 147.4 | 164.1 |

Table 5: Hardness data heat-treated in HV

4.3 Microscopy

4.3.1 Normal

4.3.1.1 A: Top

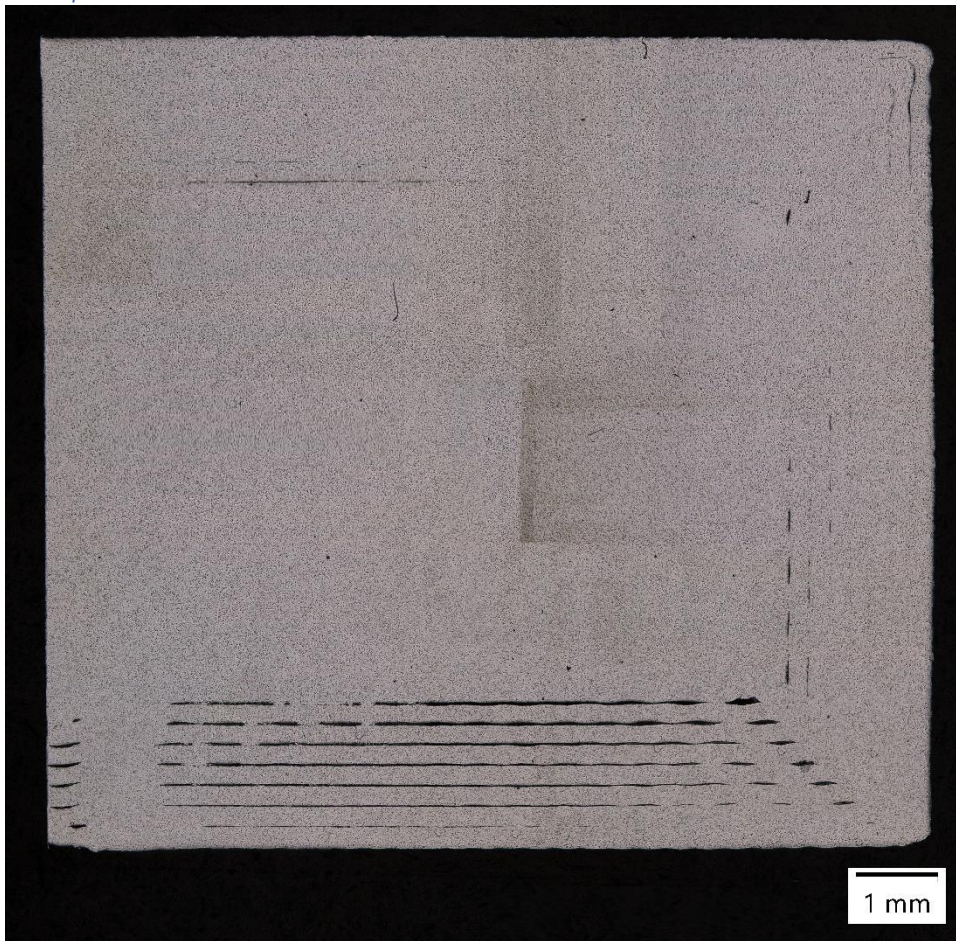

Figure 18: Microstructural overview Top As-sintered

4.3.1.2 B: Side

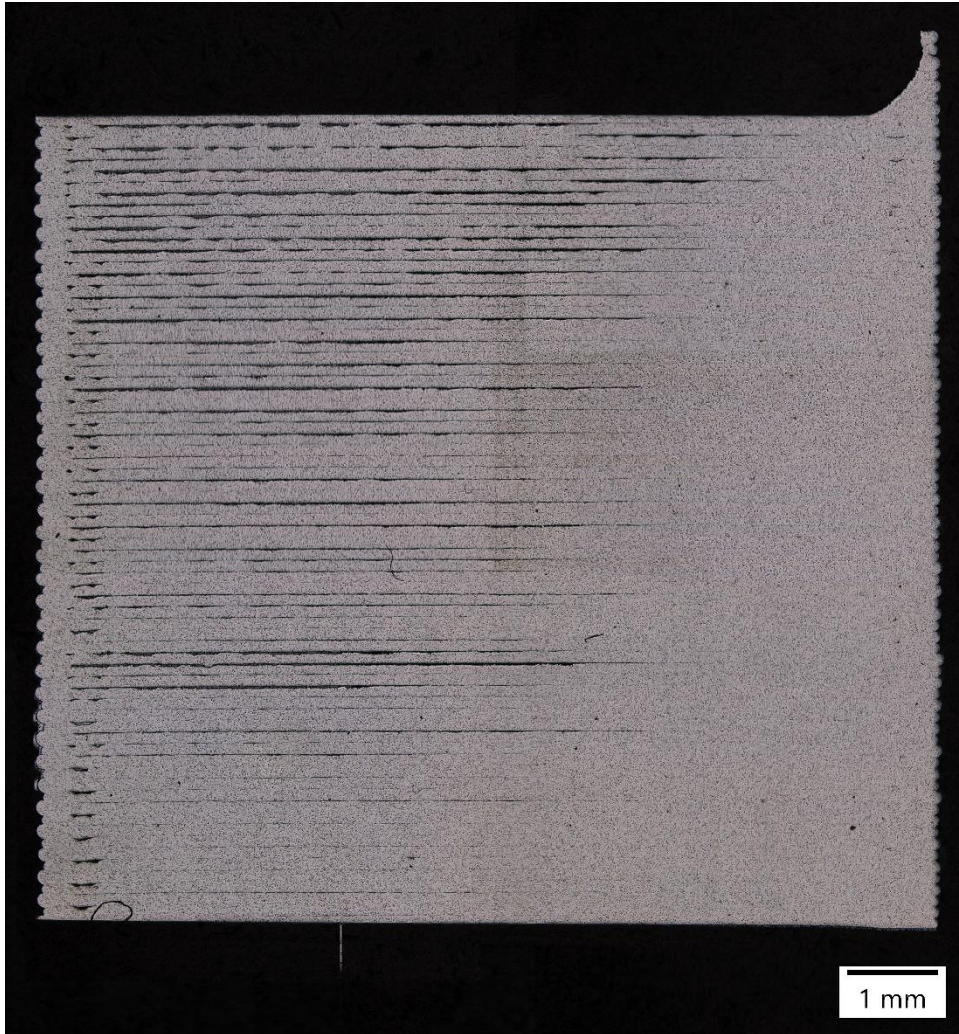

Figure 19: Microstructural overview Side As-sintered

4.3.1.3 C: Middle

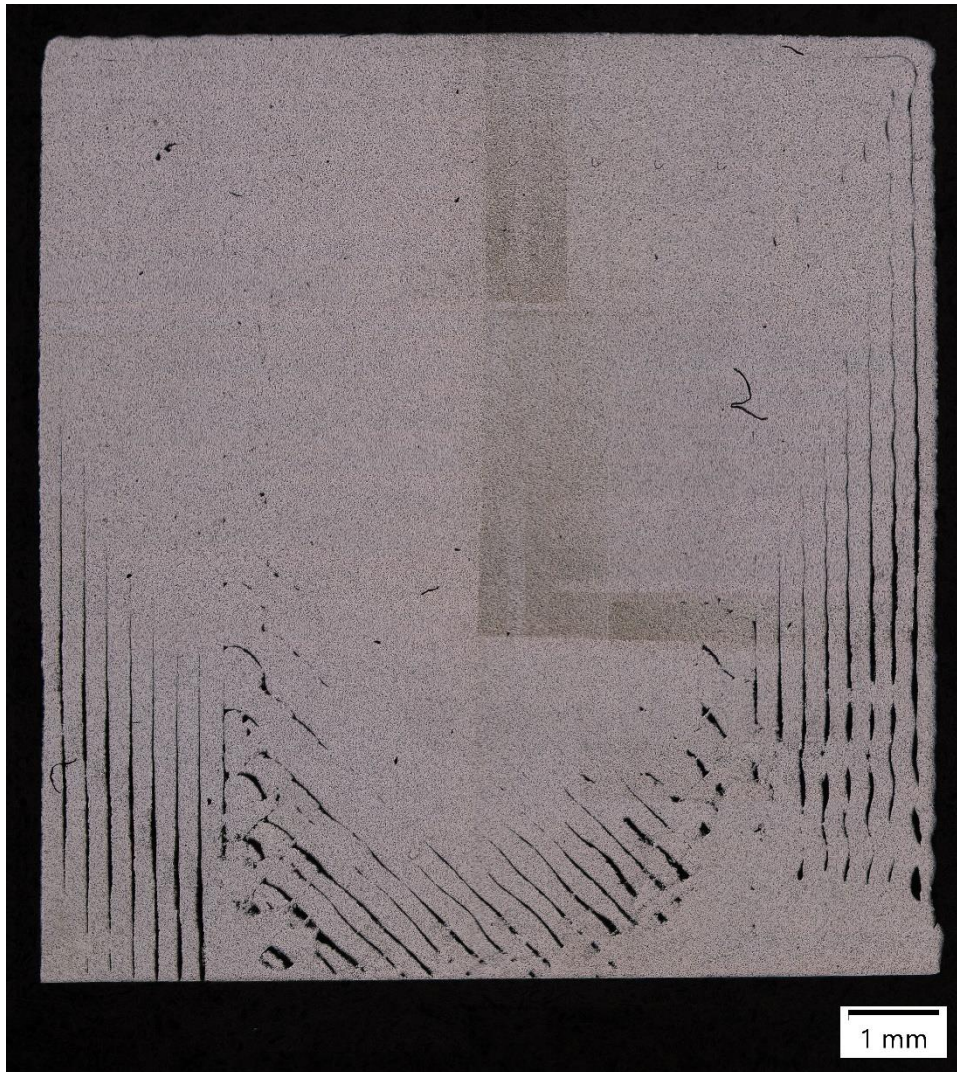

Figure 20: Microstructural overview Middle As-sintered

4.3.2 Heat treated

4.3.2.1 A: Top

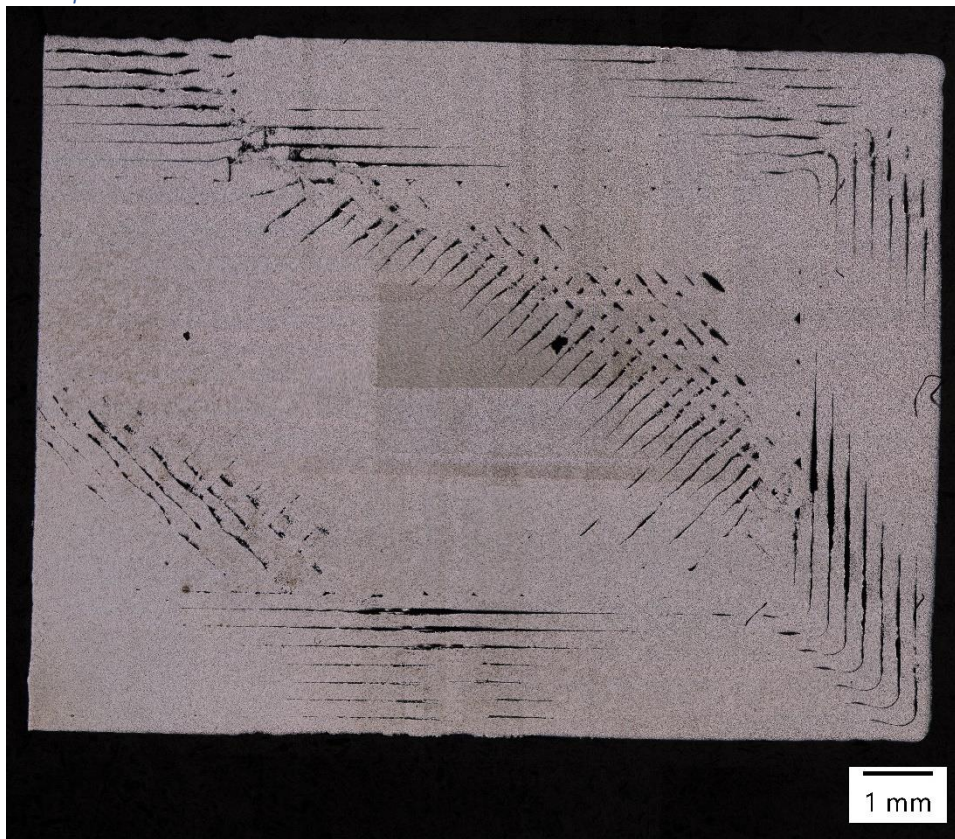

Figure 21: Microstructural overview Top H-T

4.3.2.2 B: Side

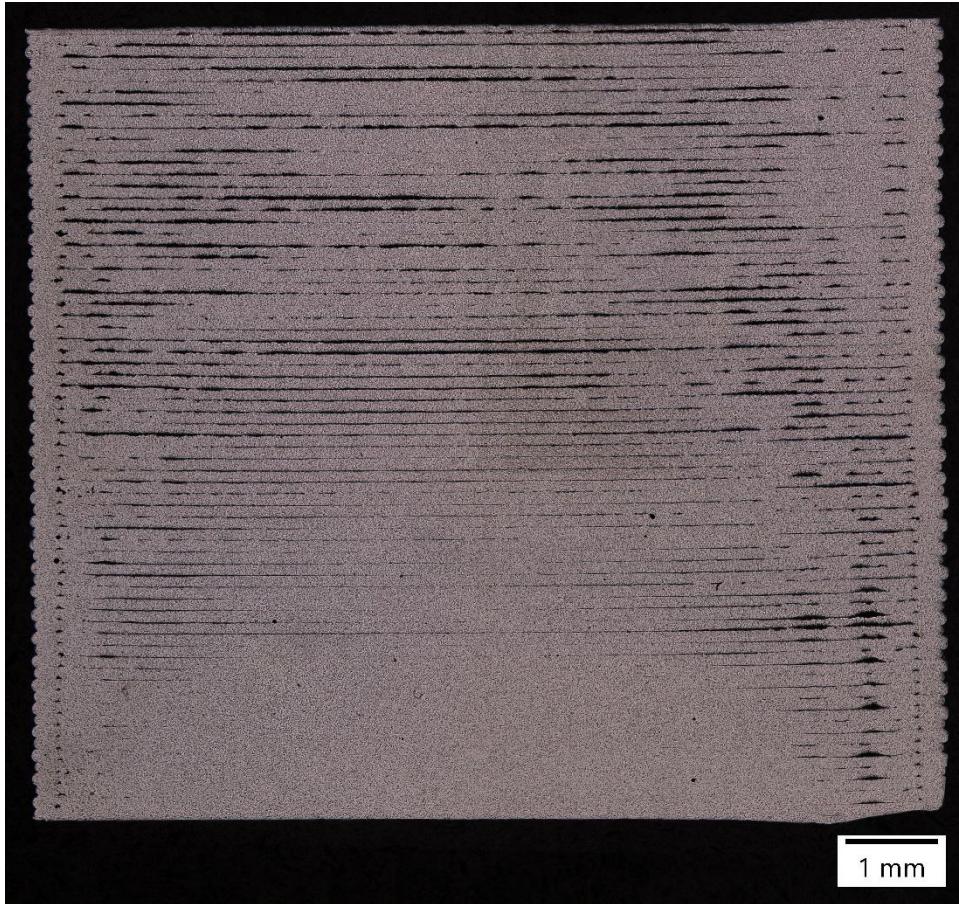

Figure 22: Microstructural overview Side H-T

4.3.2.3 C: Middle

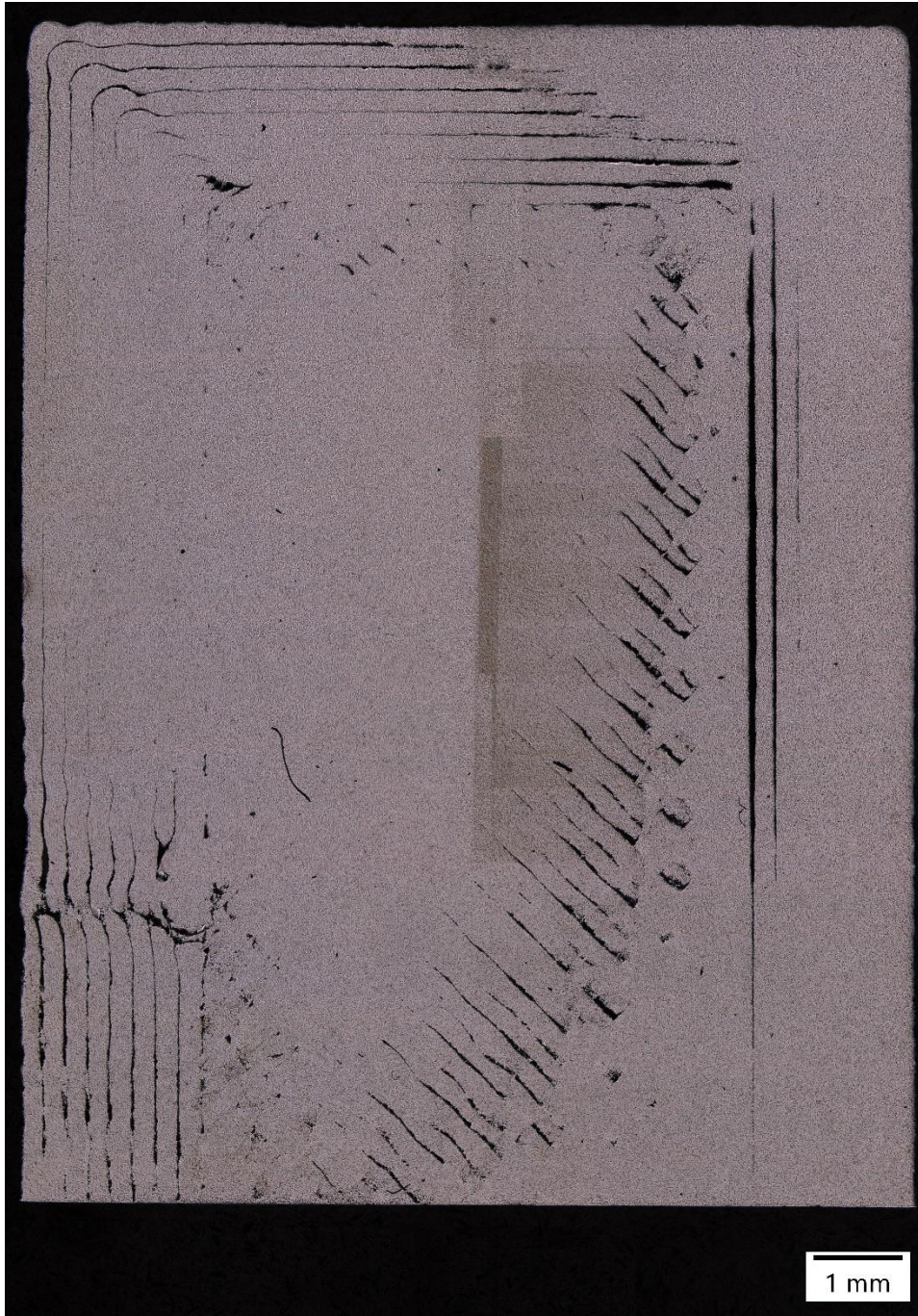

Figure 23: Microstructural overview Middle H-T

5. Analysis and discussion

5.1 Tension

5.1.1 Breakages on the specimens

As we can see in figure not all of the specimens broke in the gauge section. In fact, none of the as-sintered normal and machined specimens broke in the gauge section. Only 3 of the heat-treated specimens broke within the gauge section. Clearly something is not right with the sliced and printed model considering that they all broke at approximately the same place.

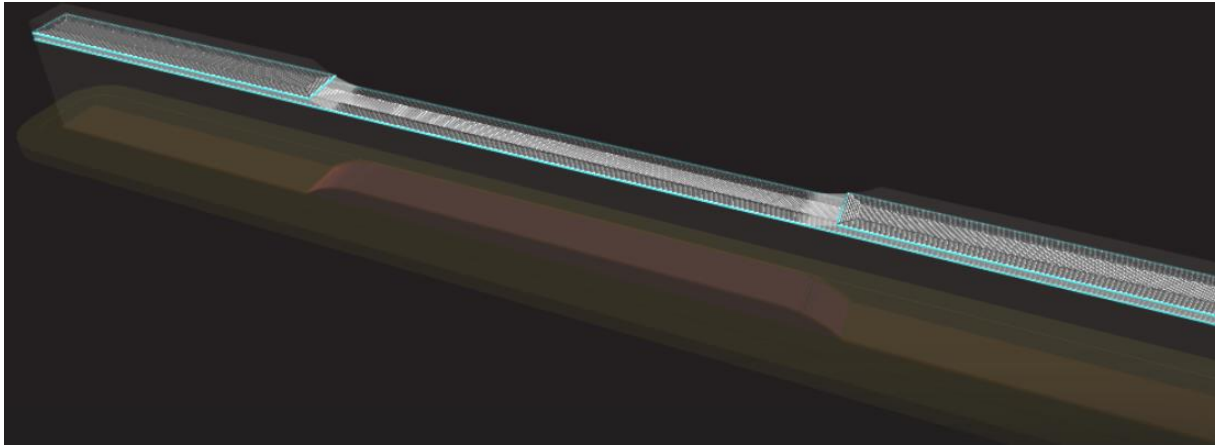

Figure 25: Preview of sliced specimen layer 152-161/177

we can see in the internal view that the layers that build up the sides of the gauge section ends in the area where the specimens have broken. These are like steps upwards making the ark when added together. Their ends of the layers may have curved up a bit if lack of adhesion was experienced. It can bend up either during printing, washing or sintering. If they were to bend up, small cavities would appear in between the layers. A good example of this is shown in figure 24.

If there were to be any defect in the print in this area, it would look similar to the “vertically built” example in figure 24.

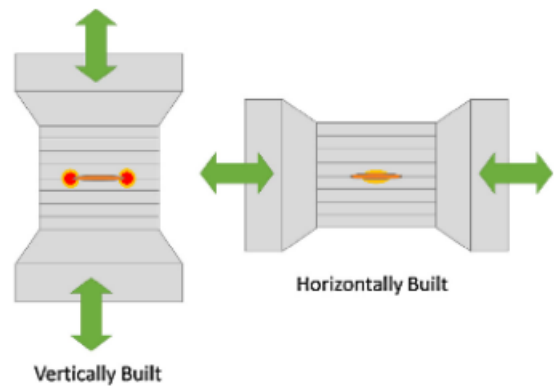

Figure 24: Illustration on impurities in specimen under load

What makes the place of breakage harder to understand is shown in figure 26. There we can clearly see the end of printing layer in the middle of the gauge area. Our prediction was that it would snap at this point as it is a “impurity” in the specimen



Figure 26: Impurities in the printed specimen

Figure 26 shows impurities both at the arc in the end of the gauge section as well as in the middle.

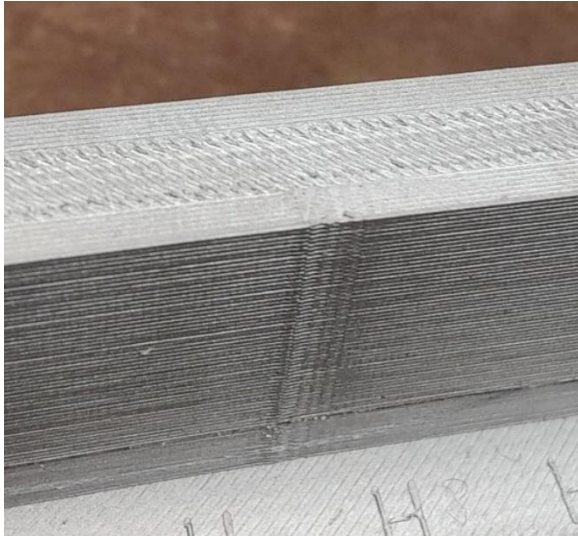

Figure 28: Impurities in middle of gauge section

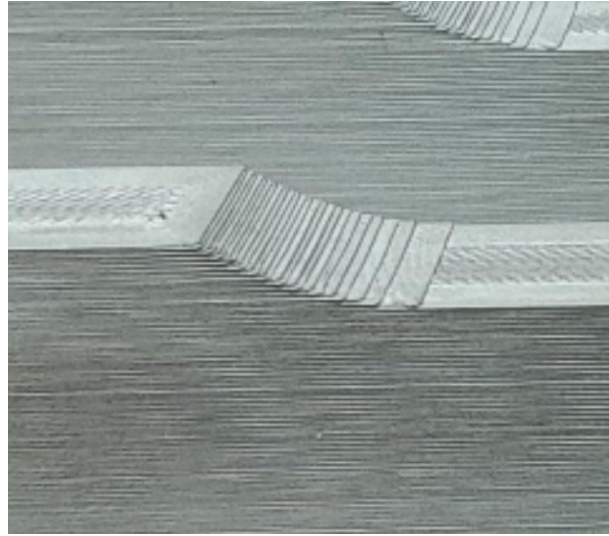

Figure 27: Impurities in arc at end of gauge section

Figure 27 and 28 shows a closeup on the impurities in the printing.



Figure 29: overview, breakage on specimens

In figure 29 we see the breakages on the as-sintered normal on the right, heat-treated in the middle and as-sintered machined on the left.

5.1.2 Differences

If we have a look at the differences between as-sintered normal, heat-treated, as-sintered machined and raw H13 tool steel. We can clearly see a difference.

| | Navn | E [GPa] | ReH [MPa] | ReL [MPa] | Rp0.2 [MPa] | Rm [MPa] | Forlængelse Rm [%] | Forlængelse brudd [%] |
|----|-------------|---------|-----------|-----------|-------------|----------|--------------------|-----------------------|
| 3 | Normal 1 | 114.9 | ----- | ----- | 660.3 | 1059 | 0.55148 | 0.55148 |
| 5 | Normal 2 | 114.3 | ----- | ----- | 673.7 | 1079 | 0.66109 | 0.66109 |
| 6 | Normal 3 | 115.2 | ----- | ----- | 628.5 | 939.4 | 0.10709 | 0.10709 |
| 7 | Normal 4 | 110.1 | ----- | ----- | 671.4 | 1047 | 0.57910 | 0.57910 |
| 8 | Herdet 1 | 148.4 | ----- | ----- | 236.3 | 632.7 | 11.24 | 11.40 |
| 9 | Herdet 2 | 156.3 | ----- | ----- | 236.2 | 632.9 | 12.36 | 12.54 |
| 10 | Herdet 3 | 150.8 | ----- | ----- | 234.8 | 638.4 | 12.02 | 12.18 |
| 11 | Herdet 4 | ----- | ----- | ----- | ----- | 625.9 | 0.00050 | 0.00050 |
| 12 | Maskinert 1 | 113.8 | 967.6 | ----- | 663.4 | 1370 | 3.554 | 3.678 |
| 13 | Maskinert 2 | 139.7 | ----- | ----- | 666.9 | 1305 | 2.866 | 2.866 |
| 14 | maskinert 3 | 123.9 | 970.2 | ----- | 650.8 | 1310 | 3.117 | 3.242 |
| 15 | Maskinert 4 | 126.6 | 957.5 | ----- | 625.6 | 1356 | 4.076 | 4.209 |

Figure 30: Data summary tension test

From the testing, the average was as follows:

| Material\data | E [GPa] | Rm [MPa] |
|-------------------------|---------|-----------|
| As-sintered normal | 113.6 | 1031 |
| Heat-treated | 151.8 | 632.5 |
| As-sintered machined | 126 | 1335 |
| Markforged as sintered | N/A | 1420 |
| Markforged heat-treated | N/A | 1500 |
| Raw H13 tool steel | 215 | 1200-1590 |

Table 6: Comparing material properties

As we can see in the table above, there are some clear differences. Especially on the heat-treated specimens. The printed heat-treated specimen is almost half the ultimate tensile strength as the datasheet from the supplier said. The reasons for this can be many. But as we did experience problems with the gas regulating sensors for the sinter during the production, the most likely reason would be insufficient heat-treatment. As this was a completely computerized process, there is little room for human error.

The as-sintered normal and machined specimens were closer to the datasheet. While not reaching the complete strength, the machined specimens came out on top only 85 MPa which means it obtained 94% strength compared to the data sheet from the supplier, and within the range of raw H13 tool steel. The difference between normal and machined specimens was a total of 304 MPa! This equals a 30% increase in tensile strength by having a machined surface!

We can clearly see that machining the surfaces of the printed objects makes a difference.

5.1.3 Problems during testing

During testing, I experienced some problems along the way. One of the problems I had was that the machined specimens were indeed too slippery for the grip in the tension tester. As we can see in figure, there are clear signs of slippage. Although it didn't slip all the way, it got some grip in the last 10mm of the specimen. How much this impacted the results is unknown. The tests had an elongation measurer on the gauge sections which makes the data still reliable.



Figure 31: Evidence of gliding in tension test machine

5.1.4 Problems during Machining

The specimens that were machined was printed a bit bigger to make room for machining and end up with the same gauge section area as the other printed specimens. The first round of machining did not go to plan as the specimens were not measured in accrued enough to be properly machined at all the necessary places. So clearly machining of 3d printed parts isn't just straight forward.



Figure 32: Specimen during machining in CNC

As this was a relatively easy part to machine post-printing, and it still failed on the machining. We cannot expect other than this being a less attractive option than originally thought.

5.1.5 Printing limitations

Thinking that it would be a good idea to test the adhesion strength in between the printed layers, I printed only the guide size due to height limitations in the sinter. But during the sintering process, the test specimens collapsed right before it was getting melted together. At this stage of the sintering process the specimens are just like floating metal powder as all the binding material used during the printing evaporates.

Figure 33 shows the failed sintering of the test specimens where you can see the way they collapsed.

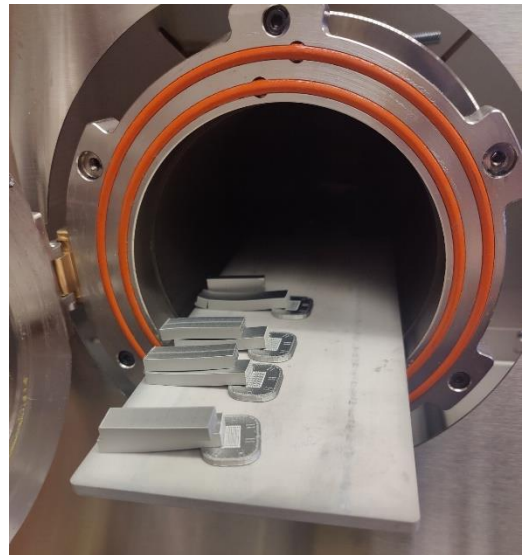

Figure 33: Failed vertical specimens

In addition to the unsuccessful sintering, we experienced a lot of problems with the sinter not wanting to start. This was most definitely due to a malfunctioning pressure sensor on the inert reserve gas. Trying to get assistance from Markforged's support team, we were met with a lot of hassle and no solutions.

The problem which didn't let us start the sintering machine is shown in figure 34.

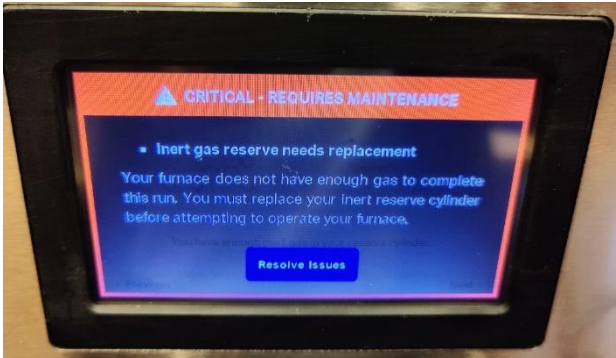
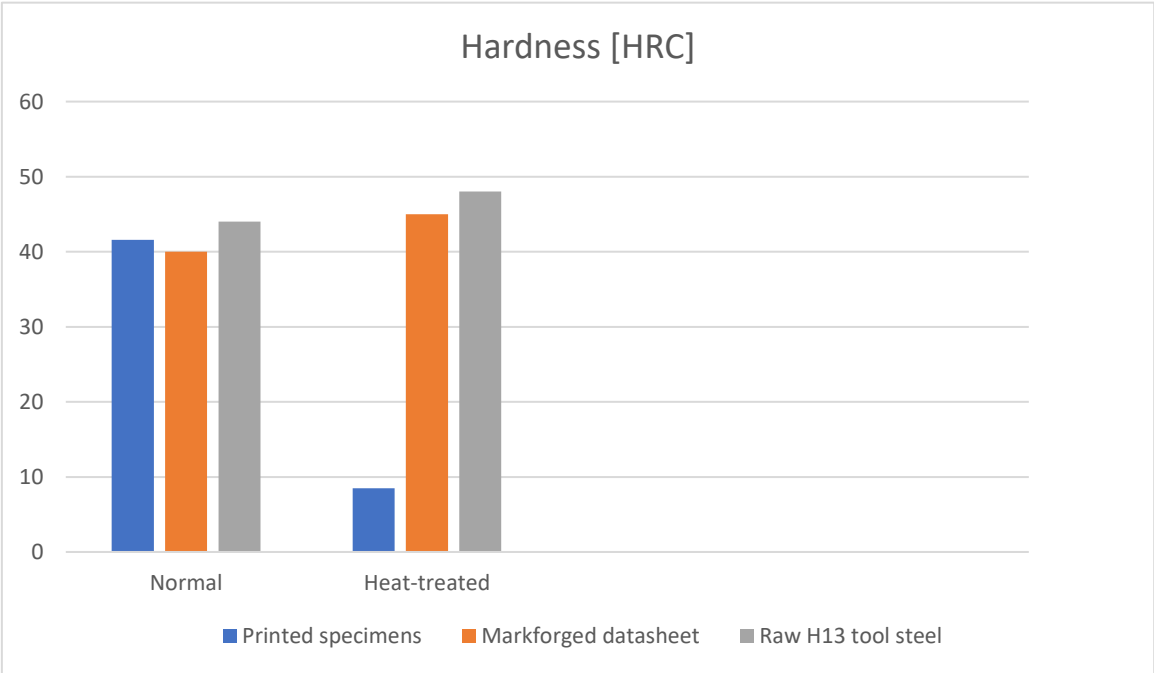

Figure 34: Fault message on sinter

5.2 Hardness

The Markforged Datasheet for their H13 tool steel says a hardness of 40 HRC (388 HV) for as-sintered, and 45 HRC (448 HV) for the heat-treated. From the tested specimens we got an average of 405,6 HV for the as-sintered, and 151,4 HV for the heat-treated specimens. As you can see in diagram, there is a vast difference from the heat-treated specimen to Markforged's datasheet and raw H13 tool steel.



In order to find out why there is such a vast difference in the hardness, we must check the hardness imprints and compare it to the software sliced preview.

As we can see in figure 35, 36 and 37. There are clearly some defects on the print specimens. In the two upper once (top and side), we can clearly see signs of cavities in the specimens. On the pictures we can see the metal physically collapsing on empty (non supported) space underneath the visible layer when we do the hardness imprint.

This knowledge can clearly explain the drop in performance compared to the datasheet. This might be a defect from the problems with the sinter.

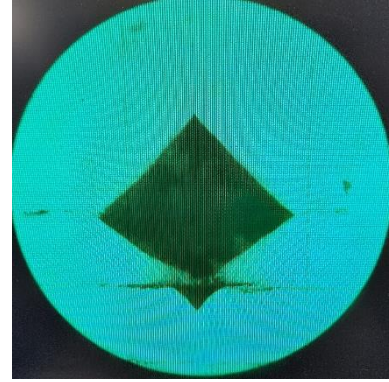

Figure 35: Top H-T

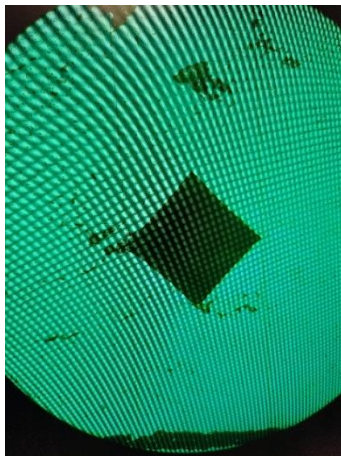

Figure 37: Middle H-T

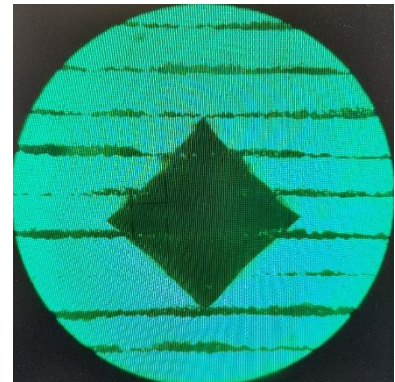

Figure 36: Side H-T

5.3 Microscopy

As we've been seeing on the microscopy and hardness results, there are clear signs of cavities and defects in the printed specimens.

In figure n we see the print bead start and end of each round done by the printer. Here we clearly see big cavities and serious lack of adhesion. This is a problem that makes this print method unreliable. If these problems can't be properly extinguished by adjusting on the print parameters. Then this print method would mostly be limited to prototyping and non-critical production.

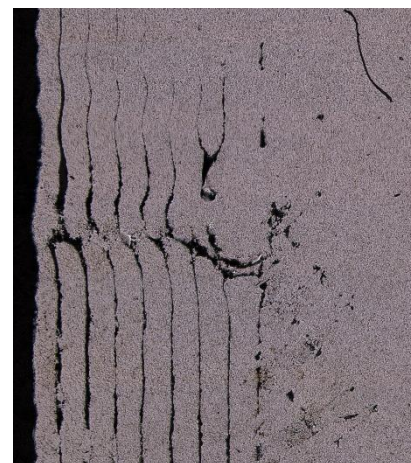

Figure 38: round seam transition

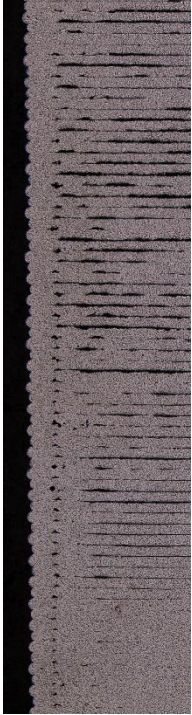

Figure 39: zoomed side view.

Figure 39 shows the side of the printed specimen. There we can easily see how the layers are more compressed the further down on the specimen we see. The cavities in-between the layers get bigger the more up on the specimen we look. This could of course be fixed with a software update. With enough testing, it should be possible to make an updated software which calculates with sagging in the part while printing. The layer height should decrease a little bit the higher on a printed part it gets.

We can also see from the side of the specimen the problem with the printed finish of the part. It is not homogenous and can easily lead to fatigue in the printed part at a much earlier point than it should have. This we also did see in the tensile test when we compared As-sintered straight from the printing and As-sintered Machined. The machined specimen had 30% higher load capacity while having the same dimensions and “material properties”.

6. Conclusion

Cavities and impurities in the printed parts results in not satisfactory quality of the printed steel. The method cannot be used to produce parts where the specified mechanical properties (according to data sheets) are required during the following use of the part. The method may be used to produce parts that do not need the full spectrum of the specified properties. However, parts subject to cyclic loads may be prone to fatigue due to the impurities. This has not been investigated in this thesis.

Being able to change parameters in the software would be an advantage, but the user would also need to have enough competence about the machine. There is a potential for getting a higher density in the parts as well as a better predictability on the material properties. With time spent on software development, there is a potential to get higher quality parts with metal filament extrusion method as well.

When looking at the facts and the data, we can conclude that there is an advantage to machine the printed parts to get a finer surface finish on the part. This limits early fatigue due to an uneven surface from the print process.

There are uncertainties related to the problems we experienced during the production phase. It has not been possible to quantify how these problems may have influenced the results.

Proposal for further work may be to run fatigue testing of some test pieces to obtain an understanding on how the impurities may affect fatigue properties in steel produced by this method.

7. References

3DEO, n.d. *3DEO*. [Online]

Available at: <https://www.3deo.co/featured/metal-3d-printing-processes-metal-extrusion-fff-fdm/>

[Accessed 14 06 2022].

Additive manufacturing research group, 2022. *Additive manufacturing research group*.

[Online]

Available at:

<https://www.lboro.ac.uk/research/amrg/about/the7categoriesofadditivemanufacturing/binderjetting/>

[Accessed 14 06 2022].

Alagha, A., n.d. *Research Gate*. [Online]

Available at: https://www.researchgate.net/figure/Schematic-illustration-of-the-wire-and-arc-additive-manufacturing-WAAM-process-20_fig5_350012077

[Accessed 14 06 2022].

AMFG, 2020. *AMFG*. [Online]

Available at: <https://amfg.ai/2019/10/08/10-of-the-biggest-challenges-in-scaling-additive-manufacturing-for-production-expert-roundup/>

[Accessed 14 06 2022].

Ampower, 2019. *Ampower*. [Online]

Available at: <https://additive-manufacturing-report.com/technology/metal/laser-beam-powder-bed-fusion/>

[Accessed 14 06 2022].

Ampower insights, 2022. *Ampower*. [Online]

Available at: https://ampower.eu/tools/metal-additive-manufacturing/#av_section_2

[Accessed 14 06 2022].

Ampower, 2020. *Ampower*. [Online]

Available at: <https://tritoneam.com/wp-content/uploads/Ampower-Insights-vol.-6-New-Technologies-1.pdf>

[Accessed 14 06 2022].

Ampower, 2022. *Ampower*. [Online]

Available at: <https://additive-manufacturing-report.com/technology/polymer/pellet-based-material-extrusion/>

[Accessed 14 06 2022].

Equbal, A., Akhter, S., Sood, A. K. & Equbal, I., 2021. *science direct*. [Online]

Available at: <https://www.sciencedirect.com/science/article/pii/S2666964121000084>

[Accessed 14 06 2022].

Fisher-Wilson, G., 2019. *ALL3DP*. [Online]

Available at: <https://all3dp.com/1/markforged-metal-x-review-3d-printer-specs/>

[Accessed 14 06 2022].

Gao, H. & Li, H., 2021. *Friction additive manufacturing technology*. [Online]

Available at: <https://journals.sagepub.com/doi/full/10.1177/16878140211034431>

[Accessed 14 06 2022].

Hendrixson, S., 2019. *Additive manufacturing*. [Online]

Available at: <https://www.additivemanufacturing.media/articles/am-101-nanoparticle-jetting-npi>

[Accessed 14 06 2022].

Incus, 2022. *Incus*. [Online]
Available at: <https://www.incus3d.com/technology>
[Accessed 14 06 2022].

Kowen, J., 2020. *Metal AM*. [Online]
Available at: <https://www.metal-am.com/articles/unrealised-potential-the-story-and-status-of-electron-beam-powder-bed-fusion-3d-printing/>
[Accessed 14 06 2022].

Markforged, 2022. *Markforged*. [Online]
Available at: <https://static.markforged.com/downloads/h13-tool-steel.pdf>
[Accessed 14 06 2022].

Metal AM, 2022. *metal.am*. [Online]
Available at: <https://www.metal-am.com/introduction-to-metal-additive-manufacturing-and-3d-printing/>
[Accessed 14 06 2022].

Naesstroem, H., Brueckner, F. & Kaplan, A., 2022. *science direct*. [Online]
Available at: <https://www.sciencedirect.com/science/article/pii/S1526612521008550>
[Accessed 14 06 2022].

Ning, F. et al., 2020. *Research Gate*. [Online]
Available at:
https://www.researchgate.net/publication/345419351_Ultrasonic_Frequency_Effects_on_the_Melt_Pool_Formation_Porosity_and_Thermal-Dependent_Property_of_Inconel_718_Fabricated_by_Ultrasonic_Vibration-Assisted_Directed_Energy_Deposition
[Accessed 14 06 2022].

Renishaw, 2022. *Renishaw*. [Online]
Available at: <https://www.renishaw.com/en/metal-additive-manufacturing-for-uav-engine-design-optimisation--44869>
[Accessed 14 06 2022].

Science direct, 2015. *Science direct*. [Online]
Available at: <https://www.sciencedirect.com/topics/engineering/cold-spray>
[Accessed 14 06 2022].